



## ON-BOARD LANE DETECTION SYSTEM FOR INTELLIGENT VEHICLE BASED ON MONOCULAR VISION

Xiaodong Miao, Shunming Li, Huan Shen

College of Energy and Power  
Nanjing University of Aeronautics and Astronautics  
Nanjing, China, 210016  
Email: [mxdh@nuaa.edu.cn](mailto:mxdh@nuaa.edu.cn)

---

*Submitted: Aug.15, 2012      Accepted: Sep.22, 2012      Published: Dec.1, 2012*

---

*Abstract- The objective of this research is to develop a monocular vision system that can locate the positions of the road lane in real time. First, Canny approach is used to obtain edge map from the road image acquired from monocular camera mount on vehicle; Second, a matching process is conducted to normalize the candidates of road line; Third, a searching method is used for reinforce potential road lines while degraded those impossible ones; Forth, a linking condition is used to further enhance the confidence of the potential lane lines, and a K-means cluster algorithm is employed to localize the lane lines; Finally, a on board system is designed for experiment. The proposed system is shown to work well under various conditions on the roadway. Besides, the computation cost is inexpensive and the system's response is almost real time.*

**Index terms:** Intelligent transportation system, machine vision, intelligent vehicle, traffic safety, driver assistant system

## I. INTRODUCTION

Recently, the traffic problem is more and more serious with the increase of vehicles. Most traffic accidents were caused by the negligence of the drivers. In order to reduce the number of traffic accidents and to improve the safety and efficiency of the traffic, the researches and companies on Intelligent Transportation System (ITS) have been conducted worldwide for many years. Intelligent vehicle (IV) system is a component of the ITS system, which aims to assist drivers in perceiving any dangerous situations earlier to avoid the accidents through sensing and understanding of the environment around itself [1].

Up to now, there have been numerous research results falling into the field of lane recognition. In [2], the authors generate the bird's-eye view image of the road plane first by using Inverse Perspective Mapping (IPM) to remove the perspective effect. Next, it extracts the lane markers based on the road constraints and the lane marker's width. Another research work with different philosophy can be seen in [3] where a curve road model was proposed. In that work, a deformable template method is used to optimize a likelihood function based on the proposed model. However, it cost huge computational resources.

Several different strategies have been reported in the literature to deal with various road types. Edges, intensities or other lane-marking features are commonly used for lane detection of structured roads, which have obvious lane markings, clear edges, relatively high intensities and specific colours and features. For example, the AURORA system [4] used adjustable templates to track lane markings for structured roads. Kluge [5] used a deformable template model of lane structure to locate lane boundaries without thresholding the intensity gradient information. The GOLD system [6] performed lane detection based on a pattern-matching technique that relies on the presence of lane markings. The LANA system [7] captured the magnitude and orientation information of edges based on a set of frequency domain features. Wang et al. computed a potential edge field and a potential orientation field from the image and applied B-Snake or Catmull-Rom spline to model curved lanes [8, 9]. The TFALDA system [10] utilized the starting position, direction and grey-level value of a lane boundary as features to recognize the lanes. The VioLET system [11] utilized steerable filters for lane-marking detection and used an adaptive template to estimate road curvature.

For unstructured roads that have no obvious lane markings or lane boundaries, color and texture information combined with edges are often employed to distinguish the road surface from the surroundings under the assumption that the color or texture of the road surface is very different from the surroundings beside the road. The SCARF system [12] used a set of Gaussians to model the colors of both off-roads and roads that have degraded surfaces and edges with no lane markings. Rasmussen [13] assumed that the color of road surface is homogeneous and utilized texture features to deal with rural roads. Gao et al. [14] presented an unstructured road detection algorithm through feature learning using colours in HSV representation. Huang et al. [15] also proposed a system based on HSV color space and road features. In addition to pure vision-based algorithms, Liu et al. [16] fused multi-sensor data acquired by both a camera and a laser range finder for unstructured road tracking. Dahlkamp et al. [17] also proposed a system with multiple sensors. The laser sensor is used to scan for flat, drivable surface area near the vehicle, and the extracted area is used as the training data for the computer vision algorithm.

Pomerleau [18] proposed a Rapidly Adapting Lateral Position Handler (RALPH) system, which constitutes an adaptive high-speed matching procedure to determine the lane's curvature and its lateral offset. Though the RALPH approach reduces computation cost for rapid response, it suffered from low precision and influenced by the insufficient parameters. There is an additional approach [19] which combines the Hough Transform and the Line-Snake model. It first divides an image into a few sub-regions along the vertical direction, and then performs the Hough transform on each sub-region to obtain an initial estimation of the lane boundaries. Afterwards, the Line-Snake model is exploited to improve the results of lane boundary detection.

There are some shortcomings in traditional methods [20-22], for example, an algorithm that performs well on structured roads could work poorly on unstructured roads, whereas an algorithm suitable for handling rural roads might not be suitable for handling highways. More specifically, edge or intensity-based methods will fail on unstructured roads because of lack of obvious edges or markings with bright intensities. On the other hand, the assumption for colour or texture-based methods does not hold for highways because the colour and texture of one lane does not have much difference from the lane right next to it.

The purpose of this work is to inherit these promising research results and further explore the potential of this challenge problem. Generally, a robust and effective lane detection approach should be comprehensive the following aspects,

- (1) Considering roads including straight, curved, painted, unpainted roads.
- (2) Shadows are presence of results from artifacts produced by trees, buildings, bridges, or other vehicles, etc.
- (3) Moderate computational complexity so that a common embedded processor can qualified; and effectively cost control so that consumer can afford.

The organization of the lecture is as follows. After a general introduction of the research issue of the intelligent vehicle system, a real time lane detection algorithm based on monocular vision has been discussed in section II. The system design includes of hardware and software procedure is developed in section III. In section IV, the real time experimental results and analysis has been discussed. Finally, the lecture has been concluded in section V.

## II. LANE DETECTION

Considering the complexity of the environment of actual lane, road line is often degraded by some factors, such as shadows, water, pavement cracks, etc, so in the lane detection process, it is difficult to achieve both high detection efficiency and robustness, so it is necessary to optimize the algorithm.

We propose an algorithm with a single camera, which can be decomposed to five steps, the scheme is depicted in Fig.1.

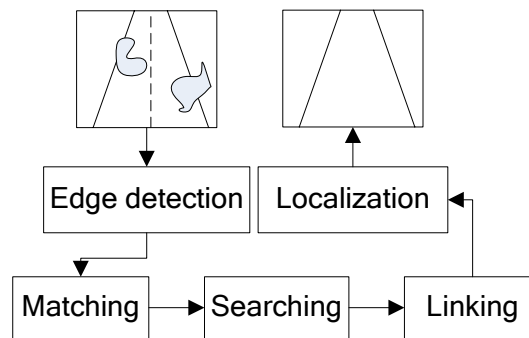

Figure 1. Block diagram of lane detection

### a. Edge detection

The goal of edge detection here is to find all present edges from road image as far as possible, because in which potential road line may be included. So a reliable and accurate edge detector should be selected firstly. There are a lot of edge detectors, for example, Canny, Sobel, Prewitt, Roberts and Laplacian operator that are usually tuned for specific type of profiles. In this work,

we use Canny approach to achieve the edge map from the road image for its accurate edge localization character, the result is shown in Fig. 2.

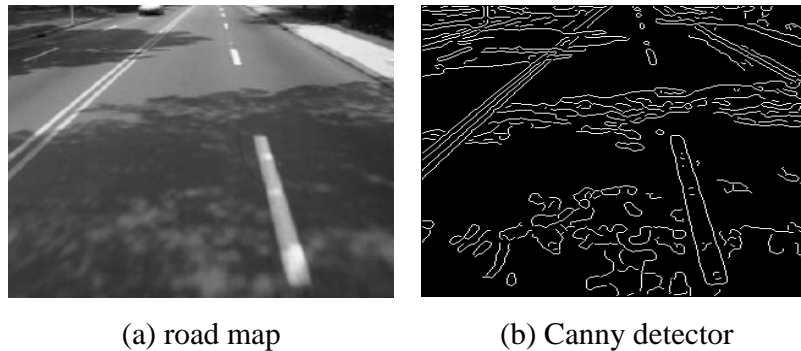

Figure 2. Edge detection

### b. Matching

After edge detection, the edge map is obtained. However, it is including too many unwanted figures that should be eliminated by subsequent steps.

Considering a  $3 \times 3$  neighboring window as shown in Fig. 3, there are only sixteen different types of line segments can appear. The front 12 types is necessary constituent components for the following procession, but the last 4 types is useless since it will be look upon two different line segments of candidate according to search for principles of below section. In practice, these 4 types of line segments usually describe disordered texture.

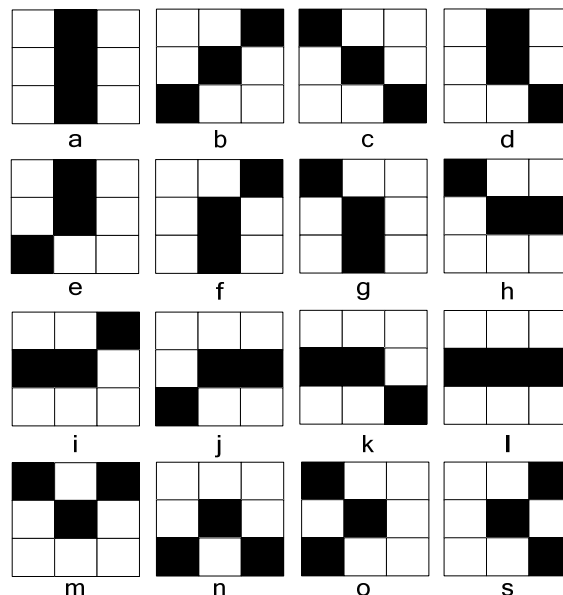

Figure 3. Models of likely line segment candidates

For each kind of line segments a specific template, called type energy, is designed. When input map image is convolved with these templates, the type of the line segment is ascertained. For example, for the first type of line segment in Figure.3 (a), let

$$\begin{aligned}
 e_1 = & 2f(x,y+1)+2f(x,y)+2f(x,y-1) \\
 & -f(x+1,y+1)+f(x+1,y)+f(x+1,y-1) \\
 & -f(x-1,y+1)+f(x-1,y)+f(x-1,y-1)
 \end{aligned} \tag{1}$$

Where  $f(x, y)$  is the value of the map image at position  $(x, y)$  and  $e_i$  is the type energy corresponding to template  $i$  among these 16 types of line segment model.

Similarly with equation (1), type energies corresponding to all the sixteen templates are computed. To avoid of same type energy value maybe product among different template, both type energy and priority are considered together. Namely, if there are two different type of line segment have same type energy, the final adjudgement about these two type decided by their priorities. In this case, the priority is ordered by a-> b-> e-> f-> i-> j-> l-> m->n->o->s for the left lane line and by a-> c-> d-> g-> h->k->l->m->n->o->s for the right lane line.

### c. Searching

A priority and orientation based searching method is used for enhance and label potential lane segments from edge map, while degraded those unwanted edge feature.

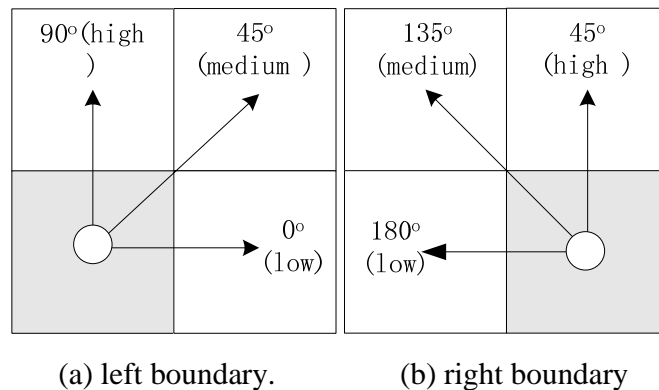

Figure 4. Direction of search.

In road image, road lanes present two intersect lines at vanishing point resulting from the image perspective. So the searching for rules should be property of preserves longitudinal and latitudinal continuity of the road markings or boundaries, while make other unwanted edges, for example shadows, disordered as much as possible, so that discard by subsequent discrimination. The search scheme descriptions as follows. As depict in Figure. 4, a local 3×3 processing window is choose to judge where, orientation in this case, the route should go on. Taking left lane for

example, the current point (darker block) just has three directions to choice, 90 degree, 45 degree and 0 degree, reference to Figure.4 (a), which is also their sequence of priority. Both lane sides use same rules except for different orientation priority; see Figure.4 (b) for right lane line case. According to this principle, a scan from left bottom, for finding the left boundary, to right top of the map image, which maximize preserved the trace of the lane line or road boundary, while disorder the irrelevance edges come from shadows, obstacles, etc. It should be note that there are two separately searching process acts on the same edge map, one pass for the left lane and the other for the right one.

After searching rules have been conducts on Fig.4 (b), a lot of insignificant line segments that separated by searching rules have been weaken now. Figure.5 (a) and (b) show the effect. In this case, a simple filter can be employed to eliminate short segments and get more pure edges map. The results is present in Figure.5 (c) and (d).

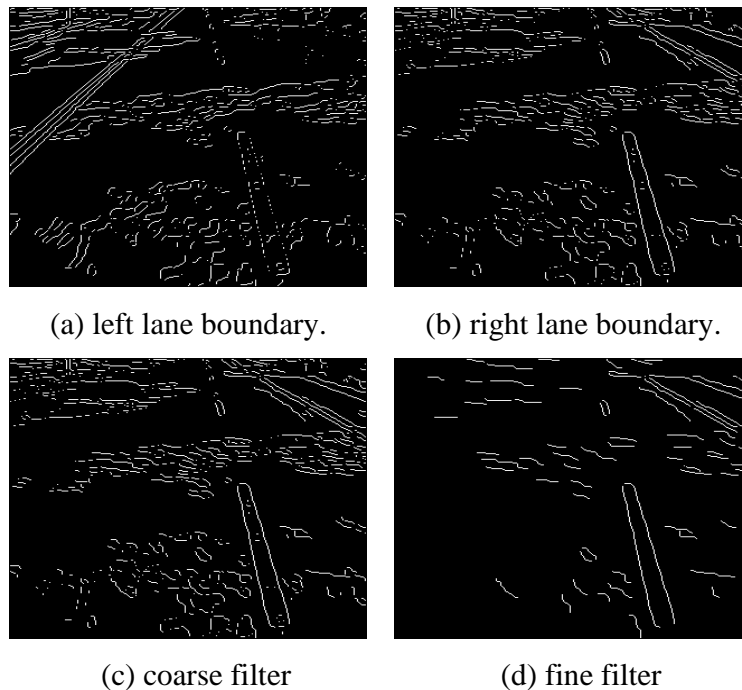

Figure.5 Searching results

#### d. Linking

Based on results from search, a linking condition is used to assemble matched segment that further strengthen the confidence of the potential lane line.

After searching step, all candidate line segments have been traversal and labeled. Although the unwanted edges have been weaken, potential lane lines may also become discontinuous. In order

to link those coherence lines into a most prominent line chain, a linking step is considering for solving this problem.

In mathematics, suppose  $P(x_i, y_i)$  to be a point in edge map and  $\theta_i$  is its orientation that can approximated calculated by equation (2)

$$\theta_i = \arg \tan\left(\frac{y_{i+1} - y_{i-1}}{x_{i+1} - x_{i-1}}\right) \quad (2)$$

In an edges map, the set of road candidate  $S$  is defined as a collection of couple of points described as follows

$$S = \{s_k | (P(x_{ks}, y_{ks}), P(x_{ke}, y_{ke}))\} \quad k = 1, 2, \dots \quad (3)$$

Where  $k$  is the total number of the edge segments in set  $S$ , the  $P(x_{ks}, y_{ks})$  and  $P(x_{ke}, y_{ke})$  is the start and last end point of the  $k^{\text{th}}$  edge.

$$\begin{aligned} \min L(d, \theta) &= d(P(x_{ke}, y_{ke}), \angle P(x_{ke}, y_{ke})) \\ &\quad + \theta(P(x_{ke}, y_{ke}), P(x_{(k+1)s}, y_{(k+1)s})) \\ \text{subject to } &0 \leq \theta(P(x_{ke}, y_{ke}), P(x_{(k+1)s}, y_{(k+1)s})) \leq \lambda \\ &0 \leq d(P(x_{ke}, y_{ke}), \angle P(x_{ke}, y_{ke})) \leq \gamma \end{aligned} \quad (4)$$

Aim to further weaken the unwanted fraction segments; a linking process should be performing. As depicted in Fig.6.

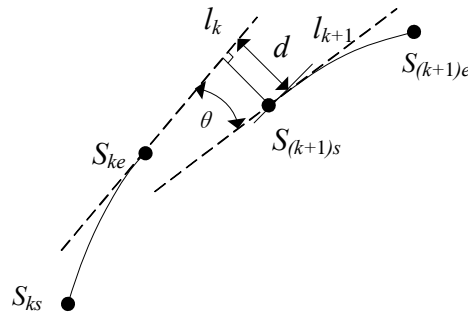

Figure 6. Linking schematic diagram

In Figure.6,  $d$  is the distance from point  $S_{(k+1)s}$  (start point of  $S_{(k+1)}$ ) to tangent  $l_k$  and  $\theta$  is angle difference between two tangents  $l_k$  and  $l_{k+1}$ . and  $\lambda, \gamma$  are two constant parameters can be adjust by user.



#### e. Localization

Finally, a conventional cluster algorithm is used to localization the lane lines. In this case, K-means cluster algorithm is chosen.

K-means clustering is a method of cluster analysis which aims to partition  $n$  observation in to  $k$  clusters in which each observation belongs to the cluster with the nearest mean. In this paper, given a set of points  $(x_1, x_2, \dots, x_n)$ , the  $k$  is decided by the priori knowledge.

After large sample statistics on the computation platform, the platform will be introduced in part 4, we get the compute time of every frame, as shown in table 1. Average processing time of each frame is 75.6 ms, which means 13 fps, can satisfy the requirements by normal speed.

Table 1. Computation cost of lane detection

	edge detection	search	linking	localization	total
Time/ms	34.7	3.2	21.3	16.4	75.6

### III. SYSTEM DESIGN

Aim to test the algorithm proposed above, an Advanced Driver Assistant System (ADAS) should be designed [23]. ADASs are inherently human-centered, since the control system must work together with the driver to achieve a safe and comfortable driving experience. The human-machine interface (HMI) provides the layer between the control system and the driver. The HMI is a very important factor in the ADAS design, because the HMI must be interpreted by the driver in a natural way, and should not reduce driver vigilance or cause compensation effects. These human factors issues involve detailed research outside the scope of this thesis, and HMI system design and validation will therefore not be further investigated.

On the other hand, the interaction with the human driver adds extra complexity to the system design, an issue that cannot be neglected in the system validation process. Unfortunately, it is often difficult to validate the HMI operation against qualitative criteria, because of the psychological elements of HMI interpretation.

In our system, with the optical sensor on the front glass, the road environment is collected through video, then using our detection methods, the lane is detected, the results display at the same time, and give drivers valid road information. The device comprises two function modules mainly: one is image acquisition module (hardware), another is processing (software) module.

a. Hardware

The hardware structure is demonstrated by Fig.7, the system's reliability, mobility are considered mainly, according to the different environment under indoor and outdoor, we select two kinds of power units, one is battery, another is AC/DC transformer, and the camera is Lm085 by Lumenera corporation, which is 100 fps under resolution of 320×240, the CPU is Intel Pentium III, 933MHz, and LCD touch screen is used to reduce the occupied space, and to optimize the users' feeling.

b. Software

OpenCV ( Open Source Computer Vision Library ) is an open source computer vision library on multi-platform by Intel, which owns strong ability in image processing and matrix computation[24], and the algorithm is optimized according to Intel instruction set, it is free for researchers. In this paper, we design the program based on it, whose interface is similar to a navigation software by GPS .

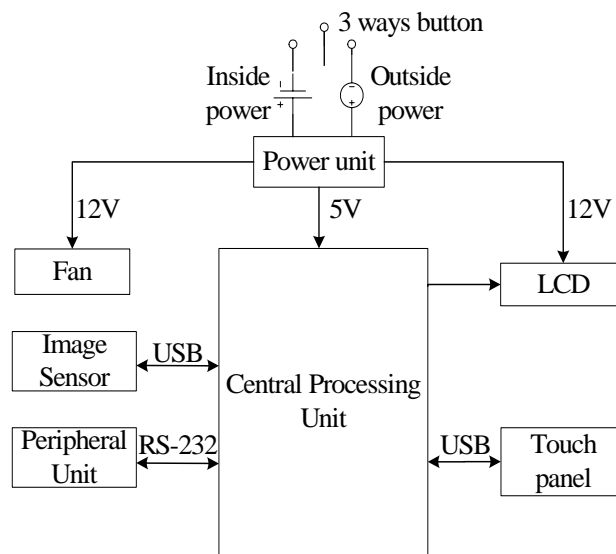

Figure 7. Diagram of hardware system

#### IV. EXPERIMENTS

a. Camera calibration

Camera calibration is a mean to determine the parameters of transformation between the image coordinate and the world coordinate. The most typical approaches with monocular camera, is the

method proposed by Zhang [25], we take international universal standard checkerboard as calibration reference to solve the constraint camera parameters.

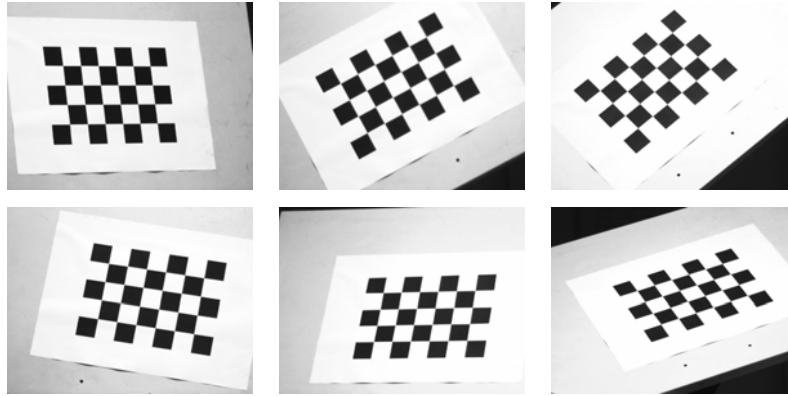

Figure 8. Checkerboard from multi-view

Fig. 8 gives a set of plates, from this calibration way, we can get the camera internal parameters are:  $x_c=158.034$  ,  $y_c=124.958$  ,  $N_x=253.462$ ,  $N_y=259.5$ . Where  $x_c$  is the reference point coordinates along X direction,  $y_c$  is the reference point coordinates along Y direction,  $N_x$  is the focal length along X direction,  $N_y$  is the focal length along Y direction.

$$\begin{aligned} X_w &= \frac{b(x-x_c)(z_w-D)}{a \cos \alpha + (y_c-y) \sin \alpha} \\ Y_w &= \frac{(z_w-D)[(y-y_c) \cos \alpha + a \sin \alpha]}{a \cos \alpha + (y_c-y) \sin \alpha} \end{aligned} \quad (5)$$

In equation (5),  $a=fN_y$ 、 $b=N_y/N_x$ .  $D$  ,  $\alpha$ , is the external parameters, the height and the angle of rotation respectively.  $a$  ,  $b$  is the internal parameters of the camera.

b. Test process

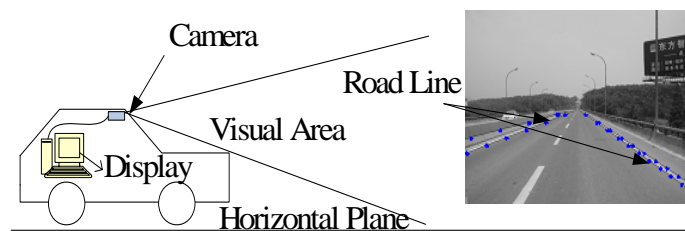

Figure 9. Scheme of experiment

The main purpose of system test is to verify the reliability and real-time of hardware and software system, which is the guarantee for future upgrades and improvements.

Experiment scheme as shown in Fig 9, from the camera on the front glass, we collect the traffic scene, and process with the system.

After calibrating the camera parameters, we install the camera on the wind screen, similar to [26]. The coach is as shown in Fig 10(a), and the installation location is shown in Fig 10(b), USB 2.0 is used to collect images real-time from sensor to the memory card, after processing the image, the results are displayed on LCD.

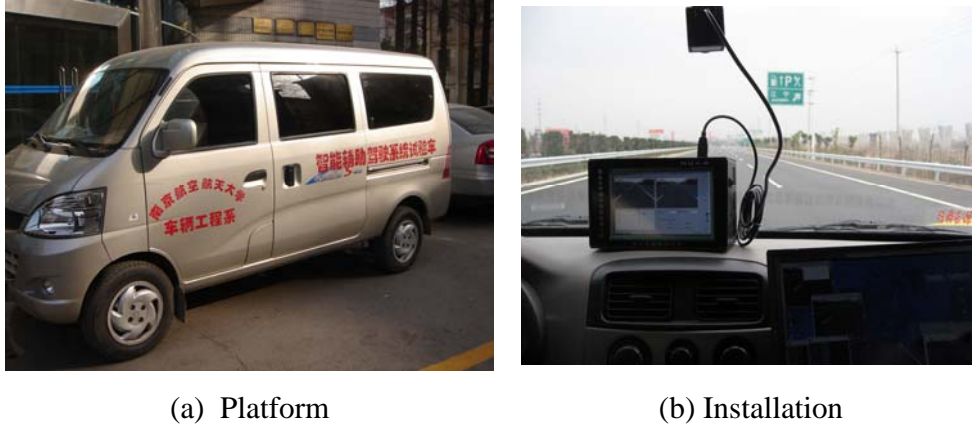
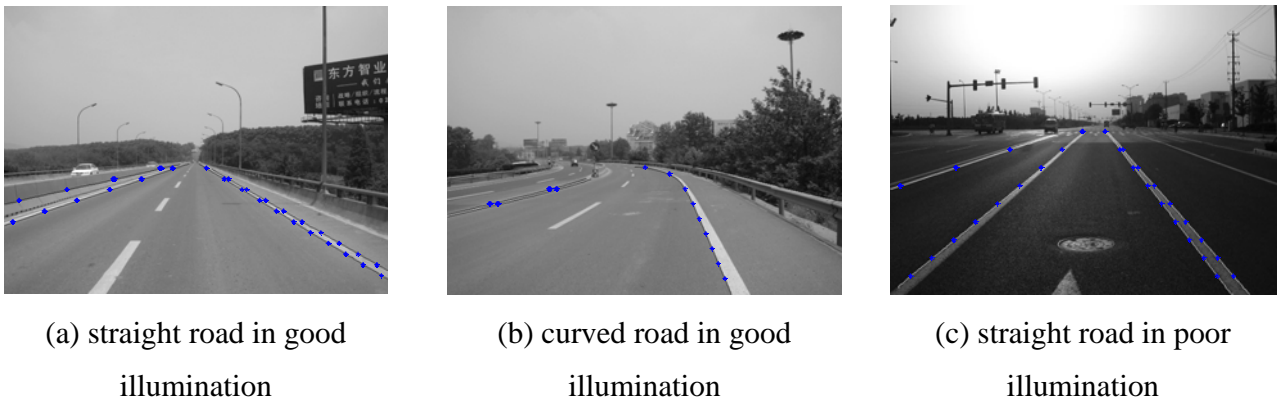
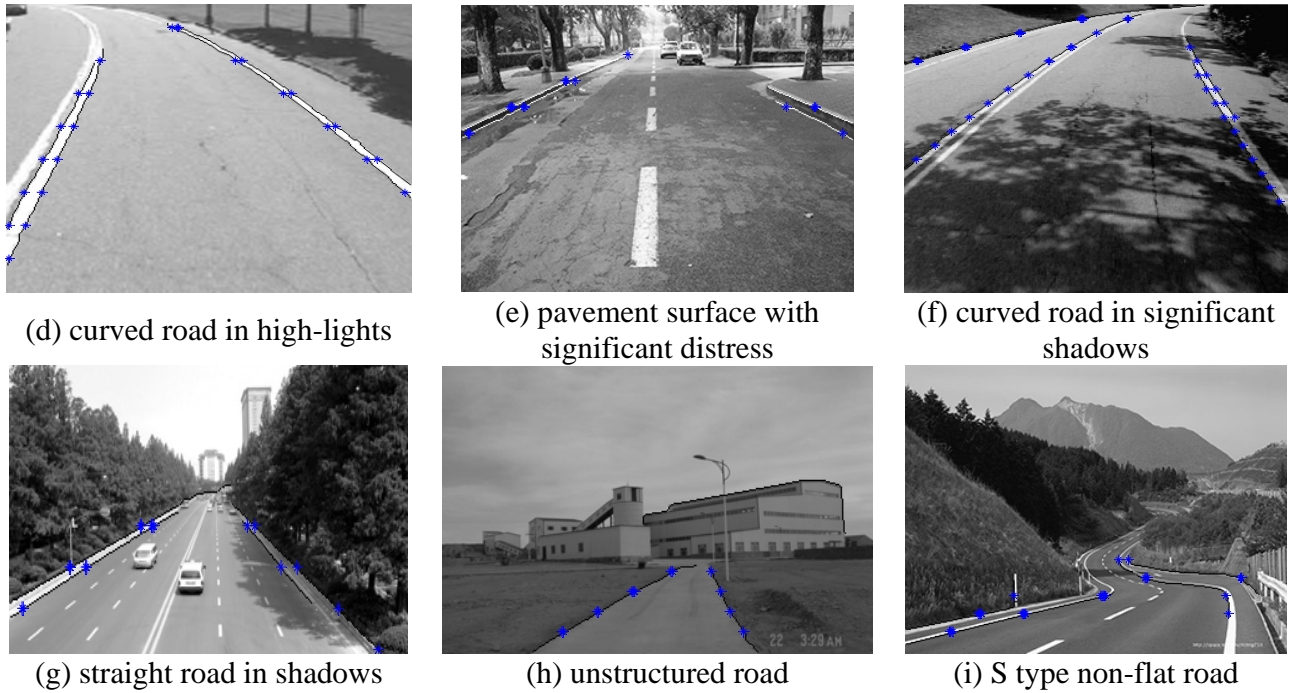

Figure 10. Test application

After these preparations, we test our system on the expressway from Nanjing to Hangzhou, in order to get enough pictures, we take video in various light and different weather, by the process, some typical results are shown in Figure 11:(a) is straight road in good illumination, (b)is curved road in good illumination, (c) is straight road in poor illumination, (d) is curved road in high-lights, (e) is pavement surface with significant distress, (f)is curved road in significant shadows, (g) is straight road in shadows, (h) is unstructured road, (i)is S type non-flat road.





## v. CONCLUSIONS

In this paper, a novel intelligent vehicle oriented lane detection approach using monocular camera is presented. Conclusions are made as following:

- (1) A five steps lane detection scheme that can successfully locate the lane line or boundary. In addition, it is also effective in various bad road scenes.
- (2) No assumptions are made about road structure, marking, or lane type, etc, so it owns a better generalize capability than others.
- (3) Plenty of experiments have been conducted and results show that the proposed method is robust to noises, shadows, illumination variations in the captured road videos, and is also applicable to both the marked and the unmarked road.

## ACKNOWLEDGEMENTS

This project was supported by the Fundamental Research Funds for the Central Universities, National Natural Science Foundation of China under Grant No. 50675099; China Postdoctoral Science Foundation funded project under Grant No. 2011M500917; Jiangsu Planned Projects for

Postdoctoral Research Funds under Grant No. 1101153C; and the Research Student Scientific Research Innovation Program in Common University and College of Jiangsu Province under Grant No.CXLX11\_0180.

## REFERENCES

- [1] Liu Yuan, Wang Yuhao, Chen Siyue. "A hybrid MAC mechanism for multiple load intelligent vehicle transportation network", *International Journal on Smart Sensing and Intelligent Systems*, 2011, Vol. 4, no. 4, pp. 662-674.
- [2] A Broggi, S Berte. "A Vision Based Road Detection in Automotive Systems: A Real Time Expectation Driven Approach". *Journal of Artificial Intelligence Research*, 1995, no. 3: 325-348.
- [3] J Goldbeck, B Huertgen, S Ernst, L Kelch. "Lane following combining vision and DGPS". *Image and Vision Computing*, 2000, Vol. 18, no. 5, 425-433.
- [4] Chen M, Jochem T, Pomerlean D. "Aurora: a vision-based roadway departure system". *Proc. IEEE Conf. Intell. Robots and Systems*, 1995, pp. 243-248.
- [5] Kluge K, Lakshmanan S. "A deformable-template approach to lane detection". *Proc. IEEE Intell. Vehicle Symp*, 1995, pp. 54-59
- [6] Bertozzi M., Broggi A. "Gold: a parallel real-time stereo vision system for generics obstacle and lane detection", *IEEE Trans. Image Process*, 1998. Vol. 7, no. 1, pp. 62 – 81.
- [7] Kreucher C, Lakshmannan S. "Lana: a lane extraction algorithm that uses frequency domain features". *IEEE Trans. Robot. Autom.* 1999, Vol. 15, no.2, pp. 343-350.
- [8] Wang Y., Teoh E.K, Shen D. "Lane detection using B-snake".*Int. Conf. Information Intelligent and Systems*, Bethesda, MD, USA, 1999, pp. 438-443.
- [9] Wang Y., Shen D, Teoh E.K. "Lane detection using spline model", *Pattern Recognit. Lett.*, 2000, Vol. 21, no. 8, pp. 677-689.
- [10] Yim Y.U., Oh S.Y. "Three-feature based automatic lane detection algorithm (TFALDA) for autonomous driving", *IEEE Trans. Intell. Transp. Syst*, 2003, Vol. 4 , no. 4, pp. 219-225.
- [11] McCall J.C, Trivedi M.M. "Video-based lane estimation and tracking for driver assistance: survey, system, and evaluation", *IEEE Trans. Intell. Transp. Syst.*, 2006, Vol. 7, no. 1, pp. 20-37.

- [12] Crisman J.D, Thorpe C.E. "SCARF: a color vision system that tracks roads and intersections", *IEEE Trans. Robot. Autom.* , 1993, Vol. 9, no. 1, pp. 49-58.
- [13] Rasmussen C. "Grouping dominant orientations for ill-structured road following". *Proc. IEEE Comp. Soc. Conf. Computer Vision and Pattern Recognition*, July 2004, pp. 470-477.
- [14] Gao Q, Luo Q, Moli S. "Rough set based unstructured road detection through feature learning". *IEEE Int. Conf. Automation and Logistics*, August 2007, pp. 101-106.
- [15] Huang J, Kong B, Li B., Zheng F. "A new method of unstructured road detection based on HSV color space and road feature". *Int. Conf. Information Acquisition*, July 2007, pp. 596 – 601.
- [16] Liu H.J, Zhang H.F, Lu J.F, Yang J.Y. "Quantitative evaluation and information fusion of road edges for accurate unstructured road tracking". *Int. Conf. ITS Telecommunications*, June 2006, pp. 318-321.
- [17] Dahlkamp H, Kaehler A, Stavens D, Thrun S, Bradski G. "Self-supervised monocular road detection in desert terrain". *Robotics: Science and Systems*, Philadelphia, PA, June 2006.
- [18] D Pomerleau, T Jochem. "Rapidly Adapting Machine Vision for Automated Vehicle Steering". *Machine Vision*. 1996, Vol. 11, no. 2, pp.19-17.
- [19] Y Wang, E K Teoh, D Shen. "Lane detection and tracking using B-snake". *Image Visual Compute*, 2004, Vol. 22, no. 4, pp.269-280.
- [20] Z W Kim. "Robust Lane Detection and Tracking in Challenging Scenarios". *IEEE Transactions on Intelligent Transportation System*, 2008, Vol. 9, no. 1, pp.16-26.
- [21] Kun Qian, Xudong Ma, Xian Zhong Dai, et al. "Spatial-temporal Collaborative Sequential Monte Carlo for Mobile Robot Localization in Distributed Intelligent Environments". *International Journal on Smart Sensing and Intelligent Systems*, 2012, Vol. 5, no. 2, pp. 295-314.
- [22] Cretu, A.-M.; Payeur, P. Biologically-inspired visual attention features for a vehicle classification task. *International Journal on Smart Sensing and Intelligent Systems*, 2011, Vol. 4, no. 3, pp. 402-423.
- [23] Shen Huan, Li Shunming, Miao Xiaodong, et al. "Intelligent Vehicles Oriented Lane Detection Approach under Bad Road Scene". *IEEE the Ninth International Conference on Computer and Information Technology*. Xiamen, China, 2009, pp.177-182.
- [24] S. S. Huang, C. J. Chen, P. Y. Hsiao, and L. C. Fu, "On-Board Vision System for Lane

Xiaodong Miao, Shunming Li, and Huan Shen, On-board Lane Detection System for Intelligent Vehicle Based on Monocular Vision

Recognition and Front-Vehicle Detection to Enhance Driver's Awareness", IEEE International Conference on Robotics and Automation, 2004, 2456-2461.

[25]Z. Zhang. "A Flexible New Technique for Camera Calibration". Transactions on Pattern Analysis and Machine Intelligence, 2000, Vol. 19, no. 11, pp.1330-1334.

[26]Yingying Huang, Ross McMurrin. "Development of an automated testing system for vehicle infotainment system". Advanced Manufacturing Technology. 2010. Vol. 51, no. 14, pp.233-246.