

FPGA BASED MAXIMUM POWER POINT TRACKER OF PARTIALLY SHADED SOLAR PHOTOVOLTAIC ARRAYS USING MODIFIED ADAPTIVE PERCEPTIVE PARTICLE SWARM OPTIMIZATION

Shubhajit Roy Chowdhury¹, Dipankar Mukherjee², Hiranmay Saha^{2#},

^{1,3}IC Design and Fabrication Centre,

Department of Electronics and Telecommunication Engineering,

Jadavpur University, India

²Department of Electronics and Telecommunication Engineering,

Bengal Engineering and Science University, Shibpur, India

Emails: {¹shubhajit, ³hsaha}@juicentre.res.in

²dipankarm@rediffmail.com

#Corresponding Author

ABSTRACT

The paper presents a Field Programmable Gate Array (FPGA) based tracker to accurately track the maximum power point (MPP) of a photovoltaic (PV) array. The tracking logic realized on FPGA is based on a modified version of Adaptive Perceptive Particle Swarm Optimization (APPSO) technique. Photovoltaic generation systems use MPP tracker because the photovoltaic array exhibits multiple maxima in the power voltage characteristic under partially shaded conditions. Compared to PSO, the APPSO offers flexibility in the motion dynamics of the particle in the search space through variation in perception radius, number of sampling points per directions, and the number of sampling directions. The APPSO algorithm has been suitably modified to suit to the slight changes in the maximum power point at around the maximum power point. The proposed technique uses only one pair of sensors to control multiple PV arrays. This results in lower cost, higher accuracy and also the algorithm is simple. The implementation of the algorithm on a reconfigurable architecture like FPGA ensures hardware based flexibility in the motion dynamics presented by APPSO. A comparative study is performed to compare the performance of PSO and APPSO with respect to MPP tracking. Compared to PSO that track to the MPP under partial shading conditions and reaches the MPP with 96.41% accuracy, the APPSO can track to the MPP with 97.95% accuracy. The algorithm when realized on an Altera Cyclone EP1C6Q240C8 FPGA consumes 5967 logic blocks.

1. INTRODUCTION

Clean and renewable energy source such as photovoltaic power generation is expected to be one of the key technologies to mitigate global warming. It is possible to use the PV power in distributed generation, transportation and mobile applications. However, a major challenge in using a PV source is to tackle its nonlinear output characteristics, which vary with temperature and solar insolation. The characteristics get more complicated if the entire array does not receive uniform solar insolation, as in partially shaded conditions due to passing by clouds, neighboring buildings and towers and trees and telephone poles, resulting in multiple peaks in the P-V characteristics. The occurrence of multiple local maxima due to partial shading of the PV arrays can be a real hindrance to the proper functioning of a MPP tracker. Considerable power loss is incurred if a local maximum is tracked instead of the global maximum which is the maximum power point [1-3]. It is pertinent to track and find the optimal operating voltage of PV arrays in order to increase the efficiency of PV generators.

Over the years, several researchers have studied the characteristics of PV modules and the external factors that affect them [4-6]. Walker has proposed a MATLAB based model of a PV module in [4] to simulate its characteristics for studying the effect of temperature, insolation and load variation on available power. Alonso-Gracia et al have experimentally obtained the I-V characteristics of PV module and the constituent cells to study the effect of partial shading in [5]. Kawamura et al proposed a computer simulation model in [6] to investigate the relation between the output lowering due to shaded PV cells and the change of I-V characteristics. However, the I-V and P-V characteristics of a single module considered in [4-6] do not predict the presence of multiple steps and peaks which are common in P-V characteristics of large PV arrays that receive non-uniform insolation. Even under the conditions of uniform insolation in a PV array, significant power losses can also arise from relative power losses (RPL) between modules [7-9] forming an array due to the inclusion of non identical PV modules in the group.

Few researchers have studied the effects of fluctuations of PV power on the utility and connected systems. Kern et al have studied the consequences of shading of PV due to passing by clouds on the PV power generation in [10]. Giraud et al used an ANN based model in [11] to investigate the effects of passing by clouds on a grid connected PV system with battery storage. It is customary to select a proper size of PV array in such systems [12]. Otherwise a sudden large change in PV power because of insolation variation caused by shading may lead to instability.

Various maximum power point tracking methods have been proposed and used to extract maximum power from PV arrays under varying atmospheric conditions [13-20]. Among the popular techniques available in literature are the hill climbing technique [19] and perturb and observe technique [13, 17, 18]. The 'hill climbing' technique involves a perturbation in the duty ratio of the power converter. The 'perturb and observe' technique involves a perturbation in the operating voltage of the PV array. Incremental conductance

[14] is another technique that is based on the fact that the slope of the PV array power curve is zero at maximum power point (MPP), positive on the left of the MPP and negative on the right. However, most of the schemes available in literature are suitable under ideal conditions and are not able to track the maximum power point under partially shaded conditions where more than one maximum peak are obtained in the PV array characteristics depending upon the series parallel connections of the series strings of the array experiencing different levels of solar insolation.

Several researchers have attempted in the global MPPT realization by evolving different algorithms. However, most of them [21-25] use lengthy calculations, on-line sensed data or special circuit configurations. However recent innovations have introduced novel algorithms that outperform the classical methods. In particular *Particle Swarm Optimization* (PSO) is a swarm intelligence algorithm that is used mainly for numerical optimization tasks. PSO gained increasing popularity in recent years due to its ability to solve efficiently and effectively a plethora of problems in science and engineering. PSO has been effectively used in a variety of data mining and optimization problems from power systems to composite beam structures and from medicine to operation research problems [26-41]. Such problems are characterized by discontinuities, lack of derivative information, noisy function values and disjoint search spaces [38, 39]. The dynamic essence of Swarm Intelligence provides flexibility and robustness.

Miyatake et al attempted to approach the global MPP using Particle Swarm Optimization algorithm [42]. However, the conventional particle swarm optimization suffers from some drawbacks. In a standard PSO, the further the particle is from the best position based on its own experience and its neighbor, the larger a change in velocity is to be made in order to return to that best position. The acceleration limits the trajectory of particle oscillation. The smaller the acceleration, the smoother the trajectory of the particle is. However, too small an acceleration can lead to slow convergence, whereas too large an acceleration drives the particles towards infinity. The updated velocity is limited by the maximum velocity to prevent particles from moving too fast in space [4]. Kaekawkamnerdpong and Bentley proposed a Perceptive Particle Swarm Optimization (PPSO) algorithm in [43] with the objective of further closely approaching the global optimum in the search space. However, the perception radius, number of sample points and the number of sampling directions are kept constant in PPSO. This has a serious drawback. If the number of sample points per direction and the number of sampling directions are kept sufficiently low, then the algorithm runs quite fast, but we may miss the global optimum position. On the other hand, increasing the number of sampling points per direction and the number of sampling directions, we may reach the global optimum very closely, but we shall have to pay considerably for the computation time of the algorithm. With intent of compromising between the two extremes, the authors proposed a novel variation of perceptive particle swarm optimization (PPSO) called adaptive perceptive particle swarm optimization (APPSO) in their previous work [44]. In APPSO, depending upon the present position of a particle in the search space, its perception radius, and/or number of sampling directions and/or the number of sample points per direction may be varied. Since, one or more of three

parameters may be varied, hence 8 cases may arise. The Perceptive Particle Swarm Optimization proposed by Kaekawkamnerdpong is a special case of Adaptive Perceptive Particle Swarm Optimization, in which all these three parameters are kept constant. The authors in their previous work [45] have applied APPSO to track the maximum power point of PV arrays. However, when the agents reach the maximum power point in the steady state, the velocity of agents equals zero. Under such circumstances, the agents may not recognize slight change of maximum power point. Such slight change of maximum power point is possible due to continuous motion of clouds.

The current paper presents the application of APPSO in tracking global Maximum Power Point of a solar PV array more closely than that possible using PSO. However, the APPSO algorithm proposed in [44] has been modified suitably to adapt to slight changes of maximum power point by providing random velocity shifts at the maximum power points. This feature enables local search around the maximum power point and enables the photovoltaic system to sense and track quickly to the slight variations in the shading pattern around the maximum power point. The algorithm has been coded in VHDL and realized on a generic reconfigurable architecture like FPGA. The implementation of the diagnostic algorithm on a reconfigurable architecture makes it suitable for further modification of functional logic of the processor with minimum programming effort. It should be applicable to large scale PV system, resulting from series-parallel combination of solar cells.

The paper is organized as follows: Section 2 focuses on the output characteristics of the totally illuminated PV array and partially shaded PV array. Section 3 gives an overview of APPSO throwing a light on the modification of the algorithm to suit to tracking systems such as MPP tracking of solar PV array. Section 4 focuses on the application of APPSO to MPP tracking of solar PV array. The simulation results are presented in section 4.1. Section 5 highlights the FPGA based implementation of the tracking circuit.

2. POWER OUTPUT OF PARTIALLY SHADED PV ARRAY:

Figure 1 shows M series connected PV modules and their power-voltage characteristics. Each module consists of n series connected PV cells. The PV array 1 in figure 1(a) is totally illuminated by solar radiation. The graph is figure 1 (c) clearly indicates that there exists only one maximum in the P-V characteristics of PV array 1 under totally illuminated condition. However, the PV array 2 is partially illuminated by solar radiation as shown in figure 1(b). Hence corresponding to M parallel modules, there exist M maxima in the P-V characteristics under partially shaded condition as shown in figure 1(c). Hence the generated power may reduce and the PV system efficiency will decrease.

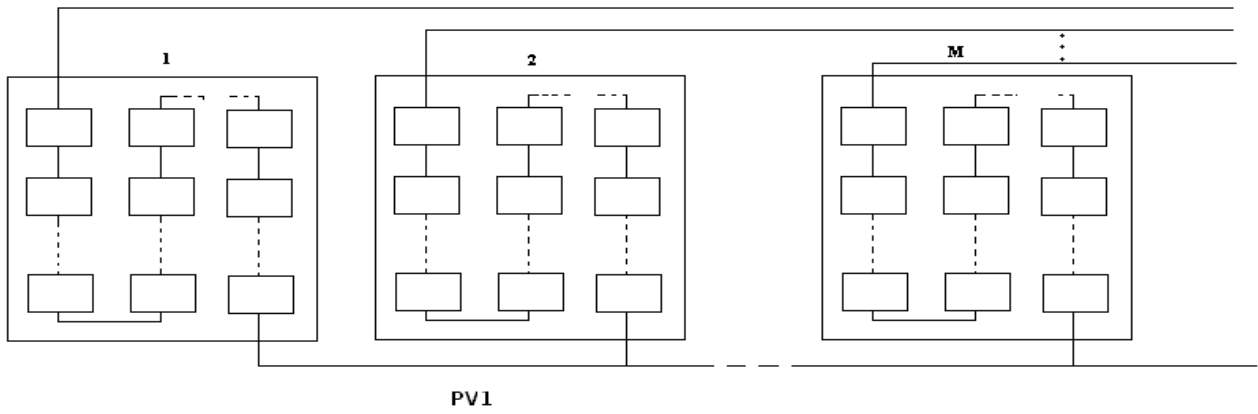

Figure 1 (a)

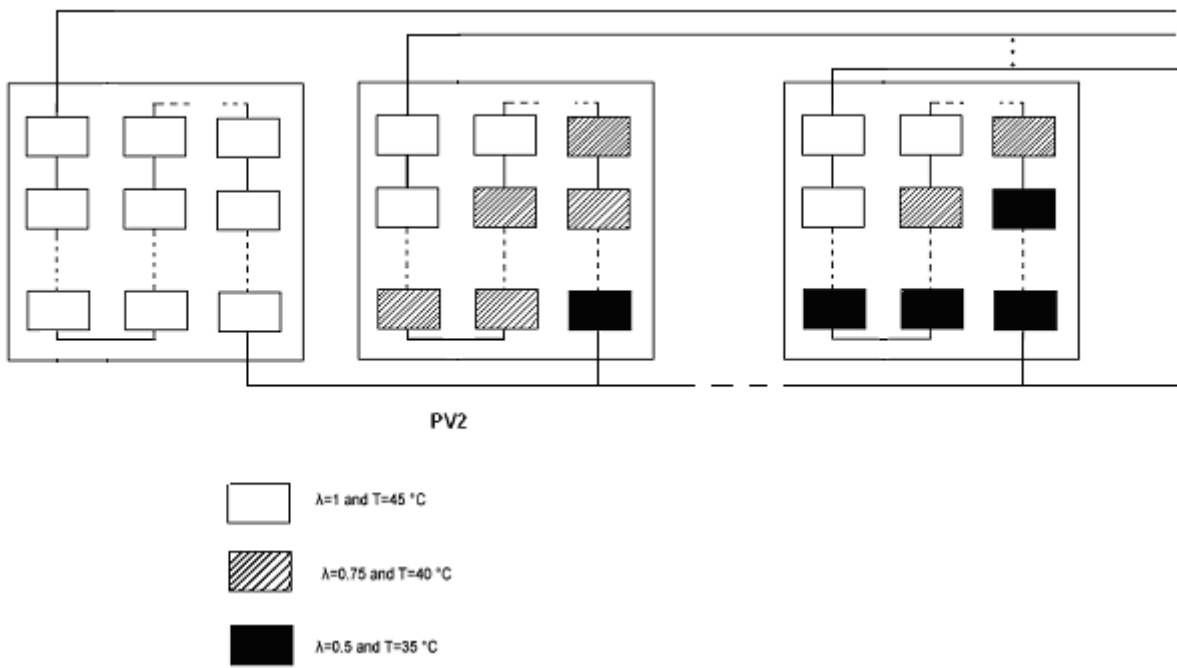

Figure 1(b)

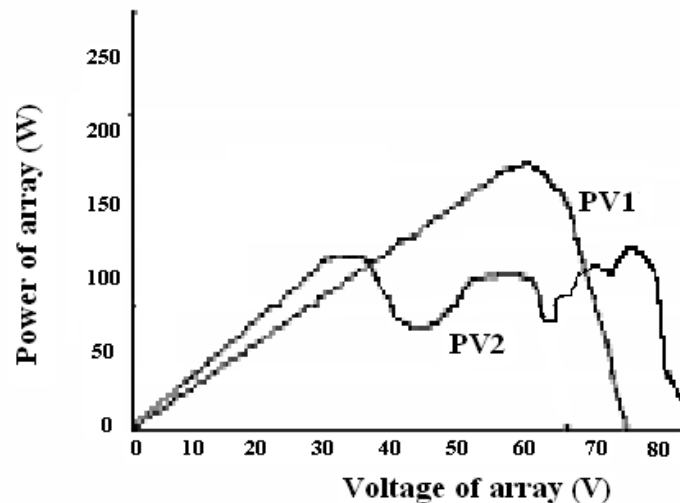

Figure 1 (c)

Figure 1. (a) PV array configuration of module PV1 (fully illuminated)

(b) PV array configuration of module PV2 (under partial shading)

(c) P-V characteristics of PV1 and PV2

3. MODIFIED ADAPTIVE PERCEPTIVE PARTICLE SWARM OPTIMIZATION:

The current work presents a modified version of the adaptive perceptive particle swarm optimization algorithm proposed by the authors in [40]. The adaptive perceptive particle swarm optimization [44] algorithm is relatively similar to the perceptive swarm optimization algorithm [43] and the conventional particle swarm optimization algorithm. However, in PPSO and in the proposed APPSO, the algorithm operates in $(n+1)$ dimensional search space. In effect, the particles fly over a physical fitness landscape observing its crests and trough from a far. However, unlike the PPSO algorithm, in APPSO algorithm, if the local best position of the particle at the current iteration does improve the performance of the particle, not only is its personal best position updated in the next iteration, but also the spacing between the sample points along any direction within the perception radius is minimized and/or the number of sampling directions is increased and/or the perception radius is minimized so as to encourage more social interaction of the particles. In APPSO also the fitness function is the average of the height of the landscape observed from all observation directions minus distance between the particle and the point of observation in the landscape. A detailed discussion of APPSO is given in [44]. However, in dynamic systems such as maximum power point tracking of PV arrays, when the agents reach the maximum power point in the steady state, the velocity of agents equals zero. Under such circumstances, the agents may not recognize slight change of maximum power point. To adapt the agents to such situations, the agent velocities have been shifted by Δv at the maximum power points. The direction of shifting is decided randomly. This feature enables local search

around the maximum power point and enables the photovoltaic system to sense and track quickly to the slight variations in the shading pattern around the maximum power point.

4. APPLICATION OF APPSO TO MPPT TRACKING OF PV ARRAY

The current work applies the APPSO algorithm to the maximum power point tracking of PV arrays. In case of constant bus voltage applications only one current sensor is sufficient for tracking the maximum power from several individual PV modules. It is called multidimensional MPPT control. The terminal voltage of the individual PV systems are grouped and represented in the form of N-dimensional row vector indicating the position vector of the particles \vec{x}^k as

$$\vec{x}^k = [V_1^k, V_2^k, \dots, V_N^k] \dots\dots\dots(1)$$

where N is the size of the row vector and indicates the number of PV strings.

The velocity vector \vec{v} can be represented as:

$$\vec{v}^k = [V_1^k - V_1^{k-1}, V_2^k - V_2^{k-1}, \dots, V_N^k - V_N^{k-1}] \dots\dots\dots(2)$$

The landscape function is the generated power that is spanning over a N+1 dimensional search space. The output vector changes and measures the power $P(\vec{x}^k)$.

$$P(\vec{x}^k) = V_1^k I_1 + V_2^k I_2 + \dots + V_N^k I_N \dots\dots\dots(3)$$

where I_1, I_2, \dots, I_N refers to the string currents in the strings with terminal voltages $V_1^k, V_2^k, \dots, V_N^k$. The output voltage vector changes in the following order $\dots \rightarrow x_1^k \rightarrow x_2^k \rightarrow x_3^k \rightarrow \dots \rightarrow x_N^k$.

For obtaining the currents, the circuit model of a PV cell is considered. The circuit model of a PV cell is shown in figure 2. The shunt resistance is ignored for the sake of simplicity which is good enough for fairly accurate models.

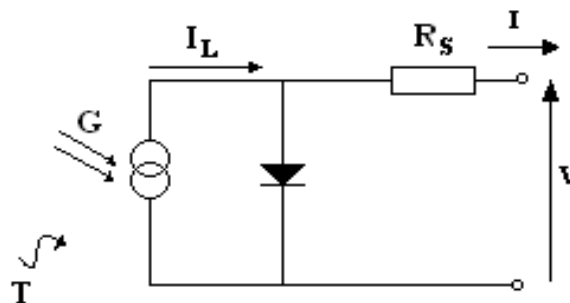

Figure 2. Circuit model of a PV cell

The current equations which describe the I-V characteristics of the cell are given in [4] as:

$$I = I_L - I_0(e^{q(V+IR_s)/nkT} - 1) \dots \dots \dots (4)$$

$$I_L = I_{L(T_1)}(1 + K_0(T - T_1)) \dots \dots \dots (5)$$

$$I_{L(T_1)} = G \cdot I_{SC(T_1, nom)} / G_{(nom)} \dots \dots \dots (6)$$

$$K_0 = (I_{SC(T_2)} - I_{SC(T_1)}) / (T_2 - T_1) \dots \dots \dots (7)$$

$$I_0 = I_{0(T_1)}(T / T_1)^{3/n} e^{-(qV_g / nk)(1/T - 1/T_1)} \dots \dots \dots (8)$$

$$I_{0(T_1)} = I_{SC(T_1)} / (e^{qV_{OC(T_1)} / nkT_1} - 1) \dots \dots \dots (9)$$

$$R_s = -dV / dI_{V_{OC}} - 1 / X_V \dots \dots \dots (10)$$

$$X_V = I_{0(T_1)}(q / nkT_1)(e^{qV_{OC(T_1)} / nkT_1} - 1) \dots \dots \dots (11)$$

where symbols have their usual meanings.

When the agents reach the maximum power point in the steady state, the velocity of agents equals zero. Under such circumstances, the agents may not recognize slight change of maximum power point. To adapt the agents to such situations, the agent velocities have been shifted by Δv at the maximum power points. The direction of shifting is decided randomly. This feature enables local search around the maximum power point and enables the photovoltaic system to sense and track quickly to the slight variations in the shading pattern around the maximum power point. The modified adaptive perceptive particle swarm optimization algorithm will be abbreviated as MAPPSO.

4.1 VHDL SIMULATION AND RESULTS

For simulation, we consider two strings of PV modules. Module PV1 is totally illuminated by solar radiation. However, module PV2 is partly under shade. Hence, in the context of the present problem $M=2$. N is set to 5. The optimal parameters of the two modules have been taken same as in [42].

The particle velocities are initialized randomly as shown in table 1:

Table 1. Initialization of particle velocities

Agent	V_1 [V]	V_2 [V]
1	$0.2V_{op}$	$0.3V_{op}$
2	$0.5V_{op}$	$0.4V_{op}$
3	$0.6V_{op}$	$0.1V_{op}$
4	$0.8V_{op}$	$0.7V_{op}$
5	$0.9V_{op}$	$0.4V_{op}$

where V_{op} refers to the open circuit voltage of the array.

Using the 8 variations of APPSO given in [40] 8 variations of MAPPSO, as well as PSO and GA, we have got the results of Maximum Power Point Tracking as shown in table 2:

Table 2. Results of Maximum Power Point Tracking obtained using different techniques

Algorithm	PV1 Voltage		PV1 Current	PV2 Voltage		PV2 Current	Power		Efficiency
	Optimal	MPPT		Optimal	MPPT		Optimal	MPPT	
APPSO1	45V	45.7V	4.13A	45V	46.8V	4.06A	391W	379W	96.93%
APPSO2		45.8V	4.12A		46.9V	4.04A		378W	96.67%
APPSO3		45.9V	4.16A		46.3V	4.12A		382W	97.70%
APPSO4		45.4V	4.18A		46.3V	4.11A		381W	97.44%
APPSO5		45.5V	4.14A		46.5V	4.09A		379W	96.93%
APPSO6		45.6V	4.13A		46.9V	4.06A		378W	96.67%
APPSO7		45.5V	4.14A		46.2V	4.08A		377W	96.41%
APPSO8		45.7V	4.16A		46.9V	4.06A		381W	97.44%
MAPPSO1		45.7V	4.13A		46.7V	4.05A		378W	96.67%
MAPPSO2		45.8V	4.12A		46.8V	4.04A		378W	96.67%
MAPPSO3		45.9V	4.16A		46.4V	4.13A		383W	97.95%
MAPPSO4		45.4V	4.18A		46.4V	4.11A		380W	97.18%
MAPPSO5		45.5V	4.14A		46.3V	4.08A		377W	96.48%
MAPPSO6		45.6V	4.13A		46.8V	4.06A		378W	96.67%
MAPPSO7		45.5V	4.14A		46.3V	4.07A		377W	96.41%
MAPPSO8		45.7V	4.16A		46.9V	4.05A		380W	97.18%
PSO		46.1V	4.06A		47.1V	4.03A		377W	96.41%
GA		46.2V	4.01A		46.9V	4.07A		376W	96.16%

An analysis of table 2 reveals that MAPPSO3 yields the Maximum Power Point that is closest to the global optimal Maximum Power Point. Moreover, we see that while using PSO, the global optimal MPP is reached with 96.41% accuracy, the MPP can be reached with 97.7% accuracy using APPSO algorithm and MPP can be reached with 97.95% using MAPPSO algorithm.

5. FPGA BASED PROPOSED HARDWARE FOR MPPT:

Based on the proposed technique, a two stage power electronic grid connected system architecture has been proposed as shown in figure 3.

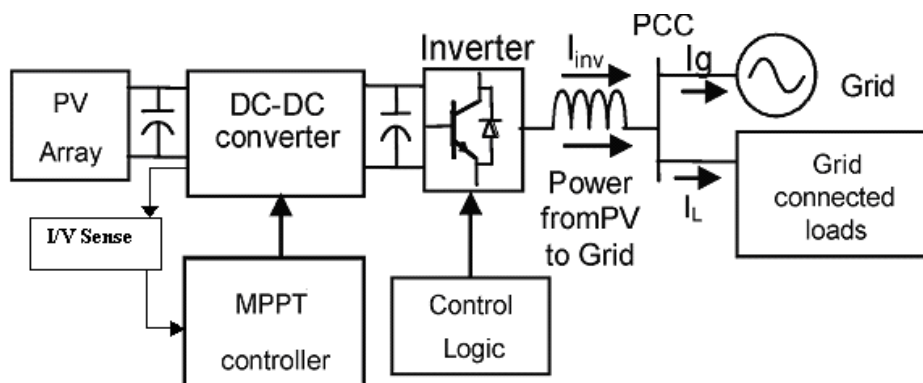
**Figure 3: System configuration for grid connected PV-based system**

The system comprises of a boost type dc-dc converter and an inverter to feed the power generated by PV array to the grid and grid connected loads. The MPPT control algorithm based on MAPPSSO has been realized on a Cyclone EP1C6Q240C8 FPGA chip. The DC-DC converter can be realized on TMS320F280X DC-DC buck converter. For converting the analog current being sensed into the digital form to be understood by the FPGA, an A/D converter ADS1208 has been used. The technology schematic of the MPPT controller as realized on the FPGA is shown figure 4.

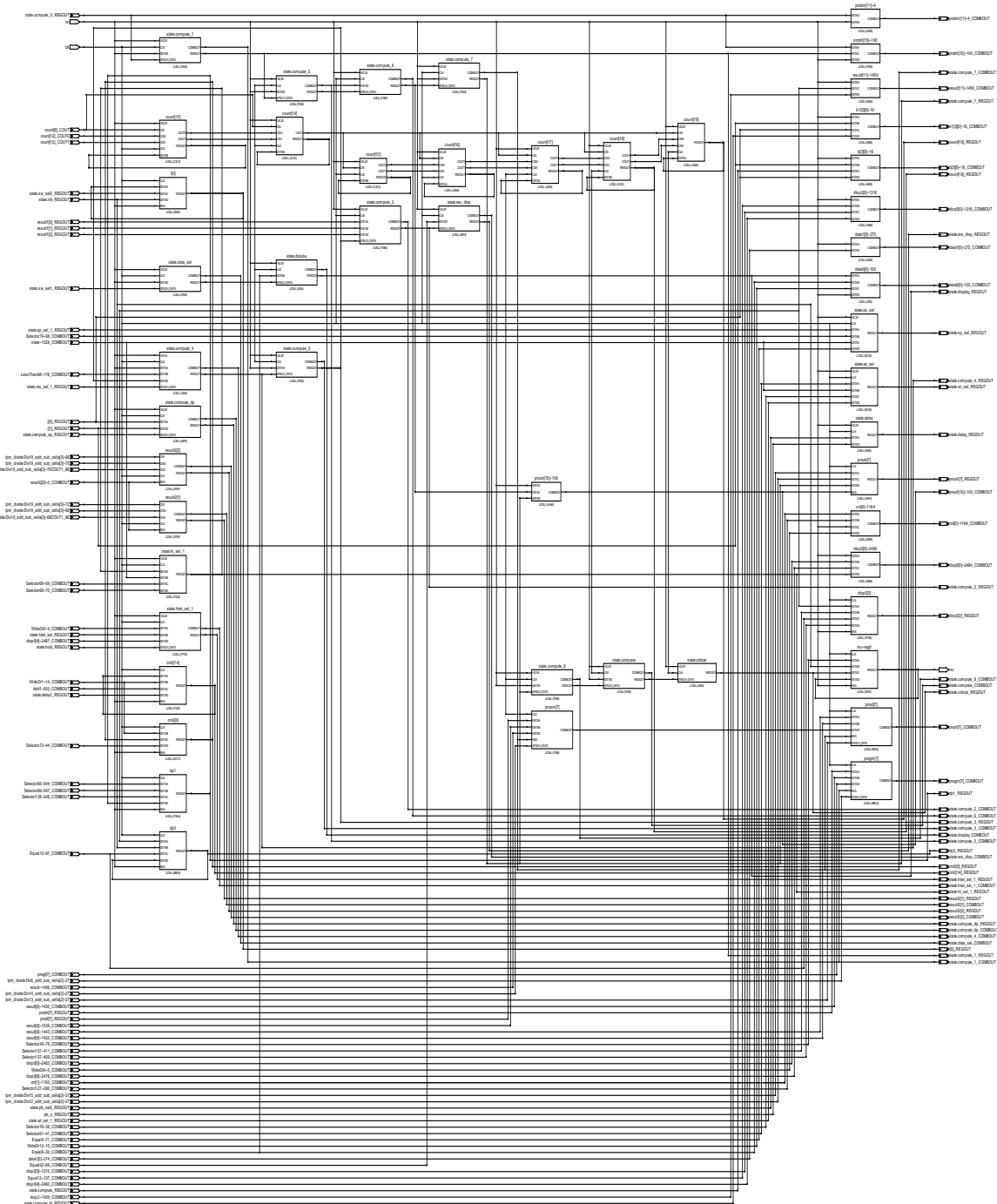

Figure 4. Technology schematic of the FPGA based MPPT controller

The value of the maximum power point is displayed on LED 7 segment displays. The whole circuit is shown in figure 5.

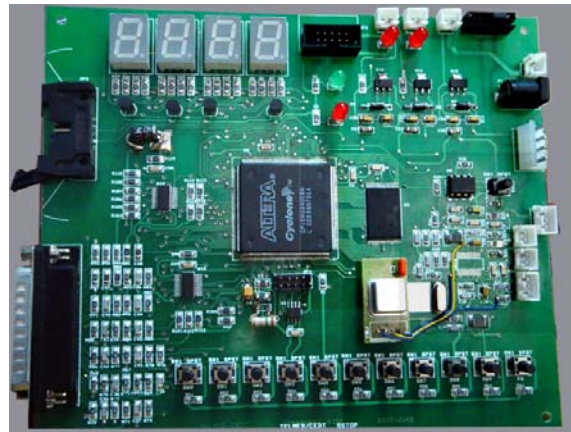

Figure 5. Control circuit for the PV array

The technology schematic shows how the look up tables (LUTs) in the FPGA chip have allocated and the connections between the different LUTs to realize the system on the FPGA. Table 3 shows the resource utilization summary of the MPPT controller.

Table 3. Resource utilization summary of the MPPT controller

Resource	Usage
Combinational logic elements with no register	4382
Registers	848
Combinational logic elements with a register	285
Total logic elements	5967 (out of 5980)
Total logic cells in carry chains	2354
I/O pins	27
Maximum fan out node	Clk
Maximum fan out	1164
Total fan out	15238
Average fan out	2.87

The resource utilization summary shows the number of different types of blocks realized on the FPGA for realizing the particular application. From table 1, it is clear that only 13 logic elements in the FPGA have been wasted in achieving an FPGA based implementation of the system. The FPGA based implementation of the system is very attractive owing to the fact that FPGAs are reconfigurable and becoming economical and faster day by day.

6. CONCLUSION:

A novel MPPT algorithm using modified APPSO technique was proposed to control several PV arrays with one pair of voltage and current sensors. The APPSO algorithm has been suitably modified to suit to the slight changes in the maximum power point at around the maximum power point. The developed algorithm is simple and also reduces cost in the data acquisition system. The proposed technique indicates that the MPP can be tracked with greater accuracy (97.95%) using modified APPSO algorithm than that is possible with the PSO or GA or even APPSO algorithm. The MPPT controller has been realized on an FPGA. The implementation of the algorithm on a reconfigurable architecture like FPGA ensures hardware based flexibility in the motion dynamics presented by APPSO. Based on the proposed technique, a two stage power electronic grid connected system configuration has been proposed. Compared to PSO that track to the MPP under partial shading conditions and reaches the MPP with 96.41% accuracy, the APPSO can track to the MPP with 97.95% accuracy.

7. REFERENCES

- [1] E. Koutroulis, K. Kalaitzakis, and N. C. Voulgaris, "Development of a microcontroller-based photovoltaic maximum power point tracking control system," *IEEE Transactions on Power Electronics*, vol. 16, no. 1, pp. 46–54, Jan. 2001.
- [2] K. H. Hussein and I. Muta, "Maximum photovoltaic power tracking: An algorithm for rapidly changing atmospheric conditions," *Proceedings of IEE Generation, Transmission and Distribution*, vol. 142, no. 1, pp. 59–64, Jan. 1995.
- [3] S. Jain and V. Agarwal, "A new algorithm for rapid tracking of approximate maximum power point in photovoltaics systems," *IEEE Power Electronics Letters*, vol. 2, no. 1, pp. 16–19, Mar. 2004.
- [4] G. Walker, "Evaluating MPPT converter topologies using a MATLAB PV model", *Journal of Electrical and Electronics Engineering, Australia*, Vol. 21, No.1, pp. 16-19, Mar. 2001.
- [5] M.C. Alonso-Gracia, J.M. Ruiz, F. Chenlo, "Experimental study of mismatch and shading effects in the I–V characteristic of a photovoltaic module", *Solar Energy Materials and Solar Cells*, Vol. 90, No. 3, pp. 329-340, Feb. 2006.
- [6] H. Kawamura, K. Naka, N. Yonekura, S. Yamanaka, H. Ohno, K. Naito, "Simulation of the I-V characteristics of a PV module with PV shaded PV cells", *Solar Energy Materials and Solar Cells*, Vol. 75, No. 3-4, pp. 613-621, Feb. 2003.
- [7] M. Shechter, J. Appelbaum and G. Yekutieli, "Quality factor of solar cell arrays", *Solar Cells*, 9(1983) 295-309.
- [8] H. Saha, G. Bhattacharya, D. Mukherjee, "Mismatch losses in series combinations of silicon solar cell modules", *Solar Cells*, 25(1988) 143-153.
- [9] T.J. Lambarski, D.L. Kadle, C.B. Rogers, "Effects of cell sorting and module matching on array output", *Proceedings of 15th Photovoltaic Specialist Conference*, pp. 841, Florida, New York, 1981.

- [10] E.C. Kern, E.M. Gulachenski, G.A. Kern, "Cloud effects on distributed photovoltaic generation: Slow transients at the Gardner, Massachusetts photovoltaic experiment", *IEEE Transactions on Energy Conversion*, Vol. 4, No. 2, pp. 184-190, Jun. 1989.
- [11] F. Giraud, Z. Salameh, "Analysis of the effects of a passing cloud on a grid interactive photovoltaic system with battery storage using neural networks", *IEEE Transactions on Energy Conversion*, Vol. 14, No. 4, pp. 1572-1577, Dec. 1999.
- [12] M.G. Jahoori, M.M. Saied, A.R. Hanafy, "A contribution to the simulation and design optimization of photovoltaic system", *IEEE Transactions on Energy Conversion*, Vol. 6, No. 3, pp. 401-406, Sep. 1991.
- [13] O. Waszynuck, "Dynamic behavior of a class of photovoltaic power systems", *IEEE Transactions on Power Apparatus and Systems*, Vol. PAS-102, No. 9, pp. 3031-3037, Sep. 1983.
- [14] P. Huynh, B.H. Cho, "Design and analysis of a microprocessor controlled peak power tracking system", *IEEE Transactions on Aerospace Electronic Systems*, Vol. AES-32, No. 1, pp. 182-190, Jan 1996.
- [15] K. Hussein, I. Muta, T. Hoshino, M. Osakada, "Maximum photovoltaic power tracking: an algorithm for rapidly changing atmospheric conditions", *IEE Proceedings of Generation, Transmission and Distribution*, Vol. 142, No. 1, pp. 59-64, Jan. 1995.
- [16] Shantharama Rai C. et al, "A novel technique for Photovoltaic Maximum Power Point Tracking System", in *Proceedings of EPE 2005*, No. 286, 2005.
- [17] N. Kasa, T. Lida, L. Chen, "Flyback Inverter controlled by Sensorless Current MPPT for Photovoltaic Power System", *IEEE Transactions on Industrial Electronics*, Vol. 52, No. 4, pp. 1145-1152, Aug. 2005.
- [18] N. Femia et al, "Optimization of perturb and observe maximum power point tracking method", *IEEE Transaction on Power Electronics*, Vol. 20, No. 4, pp. 963-973, 2005.
- [19] M. Veerachary, "Power tracking for non linear PV sources with Coupled Inductor SEPIC Converter", *IEEE Transactions on Aerospace and Electronic Systems*, Vol. 41(3), pp. 1019-1029, 2005.
- [20] Joung Hu Park et al, "Dual module based Maximum Power Point tracking control of Photovoltaic systems", *IEEE Transactions on Industrial Electronics*, Vol. 53, No. 4, pp. 1036-47, 2006.
- [21] E.V. Solodovnik, S. Liu, and R.A. Dougal, "Power Controller Design for Maximum Power Point Tracking in Solar Insolations", Vol. 19, No. 5, pp. 1295-1304, Sept. 2004.
- [22] S. Maity, "MPPT tracking of solar cells", P.G. dissertation, Department of Electronics and Telecommunication, Bengal Engineering and Science University, Shibpur, 2005.
- [23] M. Bodur and M. Ermis, "Maximum Power Point Tracking for Low Power Photovoltaic Solar Panels", in *Proceedings of 7th Mediterranean Electrotechnical Conference*, 1994, pp. 758-761.
- [24] K. Kobayashi, I. Takano and Y. Sawada, "A study on a two stage maximum power point tracking control of a photovoltaic system under partially shaded insolation conditions", in *Proceedings of IEEE Power Engineering Society General Meeting 2003*, Vol. 4, 2003.

- [25] A. Kajihara and T. Harakawa, "On considerations of equivalent model about PV cell under partial shading" Proceedings of Japan Industry Applications Society Conference IEE of Japan, Vol. 1, No. 71, pp. I 289-292, Fukui, 2005.
- [26] M.A. Abido, "Optimal design of power system stabilizers using particle swarm optimization", IEEE Transactions on Energy Conversion Vol. 17 No. 3, pp. 406–413, 2002.
- [27] D.K. Agrafiotis and W. Cedeno, "Feature selection for structure–activity correlation using binary particle swarms", Journal of Medicinal Chemistry Vol. 45 No. 5, pp. 1098–1107, 2002.
- [28] C. Fourie and A.A. Groenwold, "The particle swarm optimization algorithm in size and shape optimization", Structural Multidisciplinary Optimization Vol. 23, pp. 259–267, 2002.
- [29] C.O. Ourique, E.C. Biscaia and J. Carlos Pinto, "The use of particle swarm optimization for dynamical analysis in chemical processes", Computers and Chemical Engineering Vol. 26, pp. 1783–1793, 2002.
- [30] K.E. Parsopoulos and M.N. Vrahatis, "Recent approaches to global optimization problems through particle swarm optimization", Natural Computing Vol. 1 No. 2–3, pp. 235–306, 2002.
- [31] K.E. Parsopoulos and M.N. Vrahatis, "On the computation of all global minimizers through particle swarm optimization", IEEE Transactions on Evolutionary Computation Vol. 8 No. 3, pp. 211–224, 2004.
- [32] K.E. Parsopoulos, E.I. Papageorgiou, P.P. Groumpos and M.N. Vrahatis, "Evolutionary computation techniques for optimizing fuzzy cognitive maps in radiation therapy systems", Lecture Notes in Computer Science Vol. 3102, pp. 402–413, 2004.
- [33] K.E. Parsopoulos and M.N. Vrahatis, "Unified particle swarm optimization in dynamic environments", Lecture Notes in Computer Science Vol. 3449, pp. 590–599, 2005.
- [34] T. Ray and K.M. Liew, "A swarm metaphor for multiobjective design optimization", Engineering Optimization Vol. 34 No. 2, pp. 141–153, 2002.
- [35] K.E. Parsopoulos and M.N. Vrahatis, "UPSO: A unified particle swarm optimization scheme", Proceedings of the International Conference of Computational Methods in Sciences and Engineering ICCMSE 2004, Lecture Series on Computer and Computational Sciences Vol. 1, VSP International Science Publishers, Zeist, The Netherlands, pp. 868–873, 2004.
- [36] K.E. Parsopoulos and M.N. Vrahatis, "Parameter selection and adaptation in Unified Particle Swarm Optimization", Mathematical and Computer Modelling, Vol. 46, No. 1-2, pp.198-213, 2007.
- [37] R. Kathiravan and R. Ganguli, "Strength design of composite beam using gradient and particle swarm optimization", Composite Structures, Vol. 81, No. 4, pp. 471-479, 2007.
- [38] S. Suresh, P.B. Sujit and A.K. Rao, "Particle swarm optimization approach for multi-objective composite box-beam design", Composite Structures, Vol. 81, No. 4, pp. 598-605, 2007.
- [39] H. Feng, C. Chen, F. Ye, "Evolutionary fuzzy particle optimization vector quantization learning in image compression", Expert Systems with Applications, Vol. 32, pp. 213-222, 2007.
- [40] E. Bonabeau, M. Dorigo and G. Théraulaz, From Natural to Artificial Swarm Intelligence, Oxford University Press, New York, 1999.

- [41] J. Kennedy and R.C. Eberhart, *Swarm Intelligence*, Morgan Kaufmann, 2001.
- [42] M. Miyatake, F. Toriumi, T. Endo and N. Fuiji, "A novel Maximum Power Point Tracker controlling several converters connected to Photovoltaic arrays with Particle Swarm Optimization", *Proceedings of European Conference on Power Electronics and Applications 2007*, pp. 1-10, 2007.
- [43] B. Kaewkamnerdpong and P. Bentley, "Perceptive Particle Swarm Optimization: An investigation", *Proceedings of IEEE Symposium on Swarm Intelligence*, IEEE CS Press, Vol. 1, No. 1, pp 8-10, 2005.
- [44] S. Roy Chowdhury, D. Chakrabarti, H. Saha, "Medical Diagnosis using Adaptive Perceptive Particle Swarm Optimization and its hardware realization using Field Programmable Gate Array", *Journal of Medical Systems*, Vol. 33, No. 6, pp. 447-465, 2009.
- [45] S. Roy Chowdhury, H. Saha, "Maximum Powerpoint Tracking of Solar Photovoltaic Arrays using Adaptive Perceptive Particle Swarm Optimization Technique", 18th Photovoltaic Science Exhibition and Conference, PVSEC 18, Kolkata, January 19-23, 2009.