

Thermal Effects in Design of Integrated CMOS MEMS High Resolution Pressure Sensor

C.RoyChaudhuri¹, S.K.Datta² and H.Saha³

¹Department of Electronics and Telecommunication Engg., Bengal Engineering and Science University, Shibpur, India, e-mail: chiroosreepram@yahoo.com

²Department of Physics, City College, Calcutta University, email: swapandatta50@yahoo.co.in

³Department of Electronics and Telecommunication Engg., Jadavpur University, India, email: sahahiran@gmail.com

Abstract—Thermal effects in integrated piezoresistive MEMS pressure sensor may be a problem of concern in design for applications requiring high precision measurements and in continuously monitoring array of sensor network. It not only results in the shift of the offset voltage of the pressure sensor but also affects the performance of the adjacent CMOS circuit leading to erroneous values. To address this problem, the thermal effects of the integrated sensor chip along with its packaging arising out of the self heating of piezoresistors has been analyzed through a simple heat balance model which has been validated by FEM analysis and laboratory experiment. It is observed that for a typical packaged pressure sensor of 5.6mm by 5.6mm and heat transfer coefficient of $100\text{Wm}^{-2}\text{K}^{-1}$, thermal effect may lead to a temperature rise of around 5°C whereas for a high precision application of pressure sensor even $1\text{-}2^{\circ}\text{C}$ of temperature rise may lead to significant error. A methodology of co-design and a new MOS library called PTMOS for direct integration of these thermal effects of MEMS piezoresistors in the CMOS circuit has also been presented to reduce considerably the design cycle time of the integrated sensor. This integrated analysis thus helps in proper selection of the dimensions and packaging of the integrated sensor chip taking into account the thermal effects for the optimization of its space constraint and its performance with reduced design cycle time.

Index Terms—Thermal effects, MEMS piezoresistive pressure sensor, dynamically linked library, CMOS MEMS integration

1. INTRODUCTION

Micromachined silicon piezoresistive pressure sensors are being increasingly used in various applications. Integrating the CMOS circuit with the silicon MEMS piezoresistors in a single silicon chip enhances the functionalities of the sensor system significantly both in terms of low power consumption and low level signal processing[1-5] essential for high precision measurements. This becomes particularly important in case of continuous recording of parameters for environmental monitoring, altimeter, biomedical engineering, automotive engineering and space applications, ventilation and air-conditioning applications and also photoacoustic gas detection [6-8].

For the design of integrated CMOS-MEMS chip, it is necessary to take into account the parasitics of the MEMS and its interconnects with the CMOS circuit during layout design stage of the integrated chip. Thus it is highly desirable to have an integrated CAD tool that supports all aspects of CMOS MEMS design [9] to reduce the design cycle cost and to improve the reliability of the CMOS-MEMS chip. Unfortunately so far there is no single software available that serves this purpose satisfactorily. Presently dedicated FEM analysis software packages like ANSYS, Coventorware, Intellisuite and others is used for the MEMS design and standard CMOS CAD tools are used for the CMOS circuits. A custom extension module that includes design rules and extraction parameters of sensors has been developed to achieve error free top level DRC and LVS [9]. But the thermal considerations of the sensors and its effect on CMOS chip design have not been considered so far in any of the software packages.

However one of the important considerations for high precision measurements and continuous monitoring with the CMOS MEMS integrated pressure sensor chip are the possibilities of (i) differential electrical heating of the four piezoresistors of the Wheatstone Bridge of the pressure sensor when subjected to pressure leading to a change in the offset voltage of the bridge due to their thermal mismatch under pressure and (ii) the thermal heating of the entire silicon chip containing the MEMS and the CMOS circuit due to self-heating of four piezoresistors leading to degradation in the performance of the CMOS circuit. The thermal offset and noise may drive the transistors of the high gain stage of the CMOS circuit to nonlinear or saturation region resulting into possible error. Effects of self-heating of the piezoresistor on the output voltage of the pressure sensor have been reported earlier [10]. There are reports on the change in the offset voltage of the piezoresistive pressure sensor due to thermal variation of reverse current when the sensor is exposed to high temperature [11]. There are also reports on analysis of shift of offset voltage due to temperature effects in silicon piezoresistive pressure sensor and its compensation [12]. But there are no reports on the coupling of the thermal effects in the design of CMOS circuits namely low noise amplifiers in integrated pressure sensor. The coupled analysis will help in faster design of compensating circuits by reducing the time required for exhaustive calibration to obtain the correction coefficients. The effects of packaging on the thermal effect of the integrated microsensors due to self heating are also to be considered.

To address this problem, in this paper a methodology for direct integration of the thermal effects of the sensor chip with the CMOS circuitry output has been developed by first developing a simple analytical model taking into account the thermal effects of the MEMS and the chip and then interfacing the output of the model to the CMOS SPICE tools to be used for the CMOS circuit design. This method helps in front end coupled simulation which reduces the design cycle time considerably. To present the methodology we have divided the paper into two parts. In the first part, thermal analysis of the entire MEMS pressure sensor is first carried out using standard FEM analysis to estimate the distribution and rise of temperature not only in the piezoresistor and the membrane but also in the remaining area of the chip. The results of the FEM analysis is then utilized to develop a simple analytical model to estimate the steady state and transient temperature rise of the peizoresistor and the integrated silicon chip. The effect of packaging has been taken into account in the analysis. Finally a simple experiment is carried out with the pressure sensor fabricated in the laboratory for validating the analytical results.

In the second part of the paper, direct integration of the thermal effects of the sensor with the CMOS circuitry has been developed. The results of the analytical model of the first part to obtain the temperature rise of the integrated chip due to self heating of the piezoresistors have been subsequently incorporated in the MOS library to create a new MOS library called PIEZOTHERMOMOS (PTMOS) which is then linked dynamically with the SPICE netlist of the CMOS circuit to study its effects. The coupled simulation reduces the design cycle time significantly. With the help of coupled simulation, the shift in the output of the MOS amplifier due to thermal effects has been estimated for a particular dimension and package of the sensor chip as an illustration of its relevance in high precision pressure measurements.

2. THERMAL ANALYSIS

The objective of this analysis is to find out the steady and transient nature of temperature rise in the MEMS membrane and the integrated pressure sensor chip caused by self-heating of the piezoresistors. The schematic of the integrated chip with a single piezoresistor is shown in Fig.1. The structure of the sensor comprises of four p^+ -type piezoresistors surrounded by n-well in the p-type silicon substrate for electrical isolation. The p-type silicon substrate is bulk micromachined till the desired thickness of the membrane is reached. Electrical contacts are taken on the piezoresistors for pressure measurement. The heat source in this case is the piezoresistors which are self heated electrically due to applied voltage. To estimate the change in temperature due to applied electrical power, different pathways of heat transfer resulting in heat loss have been considered in a single piezoresistive pressure sensor electrically isolated from the substrate by a pn junction as shown in Fig.1. The pn junction surrounding the piezoresistor provides electrical isolation but no thermal isolation. The different heat loss components are: heat conduction along the basal plane membrane ($Q_{membrane}$), bulk silicon and conduction loss through air (Q_{air}) between the top and lateral surfaces of the chip and the package and also conduction loss through the bottom surface of the chip and the package through the sealing material (Q_{seal}). T_{hot} represents the temperature of the heated piezoresistor.

Considering negligible temperature gradient along the thickness of the membrane Fig.1 can be divided distinctly into three regions (not drawn to scale): the region of the doped piezoresistor, the membrane region (d) and the adjacent bulk silicon region (d_2) enclosed within a package. The gap between the package and the sensor chip in our case is filled up with air on all the three sides and on the fourth side with a thin Teflon film between the bulk micromachined membrane and the package having a hole below the membrane for application of pressure. In many other reports glass frits or organic adhesives/polymers are used as sealing material between the sensor and the package which also have poor thermal conductivity [13]. The package in our analysis has been considered to be at ambient temperature (T_a) which is true for most metal packages. Due to small size and high doping of the piezoresistors, the region of the piezoresistors is considered to be of uniform temperature. Heat is generated in the piezoresistor region when a voltage V is applied across the piezoresistor of resistance R_p for its operation. The generated heat conducts through the membrane into the bulk silicon and embedded CMOS circuit as well as through the

surrounding air inside the package and the sealing material between the bottom of the bulk silicon and the package raising the temperature of the chip.

Thermal analysis of the packaged sensor chip is first carried out by FEM analysis (Intellisuite) with single and four piezoresistors to investigate its temperature distribution as well as temperature rise. A simple analytical model is then developed to study the transient and steady state temperature rise of the packaged chip.

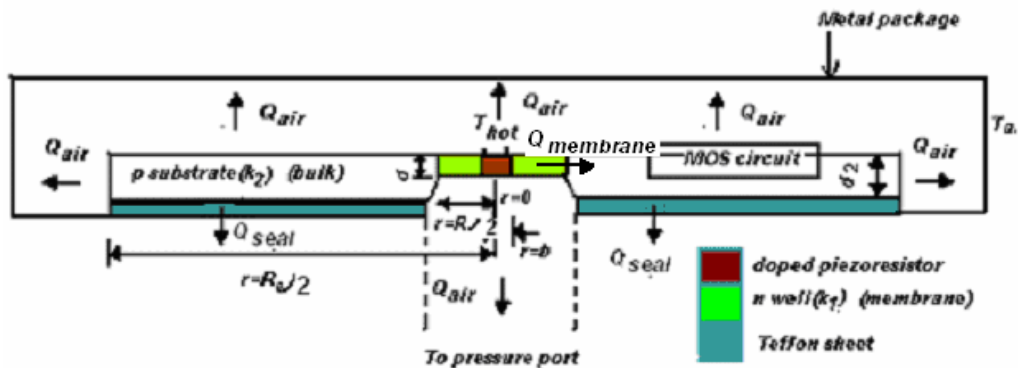

Fig 1. Schematic of the starting model of a single integrated piezoresistive pressure sensor (Not drawn to scale)

2.1 Finite element analysis

For simulation of the steady state solution, the default values of the various constants of the packaged pressure sensor chip that have been considered are:

$k_1=k_2$ (thermal conductivity of n and p silicon)= $150\text{Wm}^{-1}\text{K}^{-1}$, V (constant voltage excitation)= 5V , R_p (typical resistance of the diffused piezoresistor at steady state)= $1\text{k}\Omega$, $T_a=27^\circ\text{C}$, square, $d=20\mu\text{m}$ and $d_2=500\mu\text{m}$. The thermal conductivity values are assumed to be constant for the operating range of temperature and pressure. Identical thermal conductivities of n and p type silicon have been considered since they have almost identical electrical conductivity. The dimensions of each piezoresistors are $200\mu\text{m}$ by $50\mu\text{m}$ with a sheet resistance of 250Ω .

The finite element solution has been obtained both for a single piezoresistor and four piezoresistors as shown in Fig.2a and 2b with a chip size(R_c) of 5.6mm by 5.6mm and a membrane size(R) of 1mm by 1mm . The entire chip has been divided into electrothermal type coupled field elements and has been surrounded by air on the top and lateral sides and Teflon on the bottom side (excepting the membrane region). In our case, the air gap on all the three sides are maintained at 2.5mm and a $200\mu\text{m}$ Teflon film has been placed between the bulk micromachined side and the package with a hole below the membrane. The temperatures of the outer faces of air and Teflon are fixed at the ambient temperature of 27°C as boundary condition.

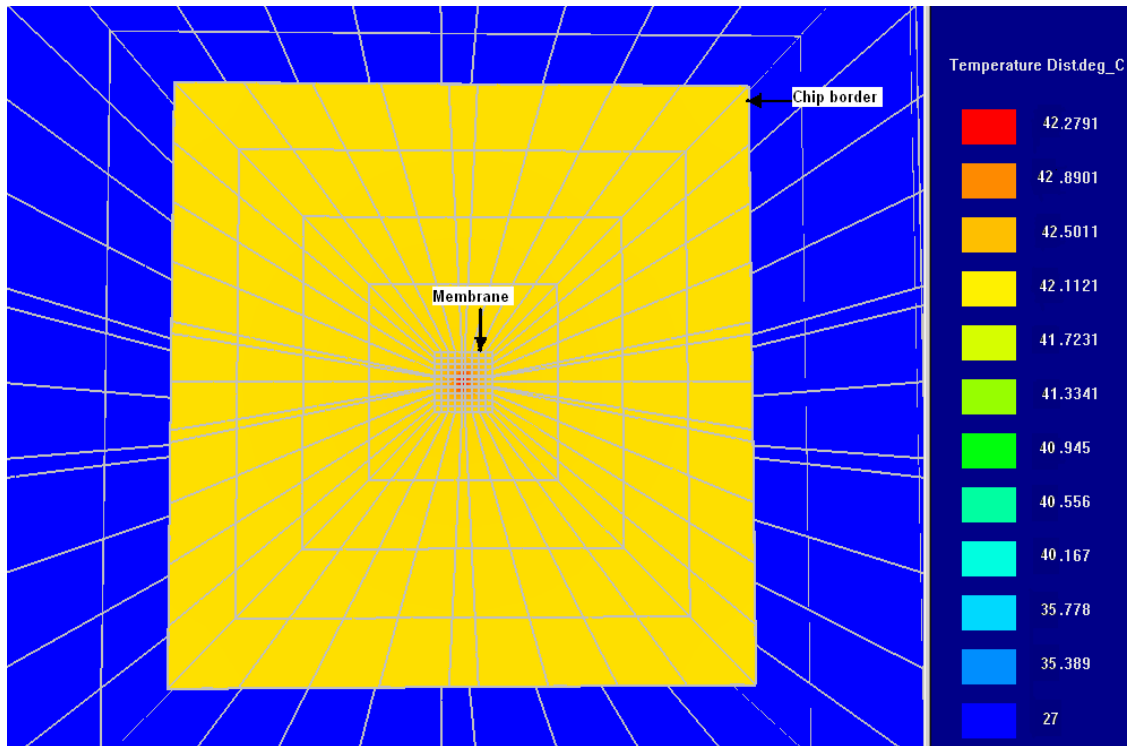

Fig.2a Temperature distribution with a single piezoresistor

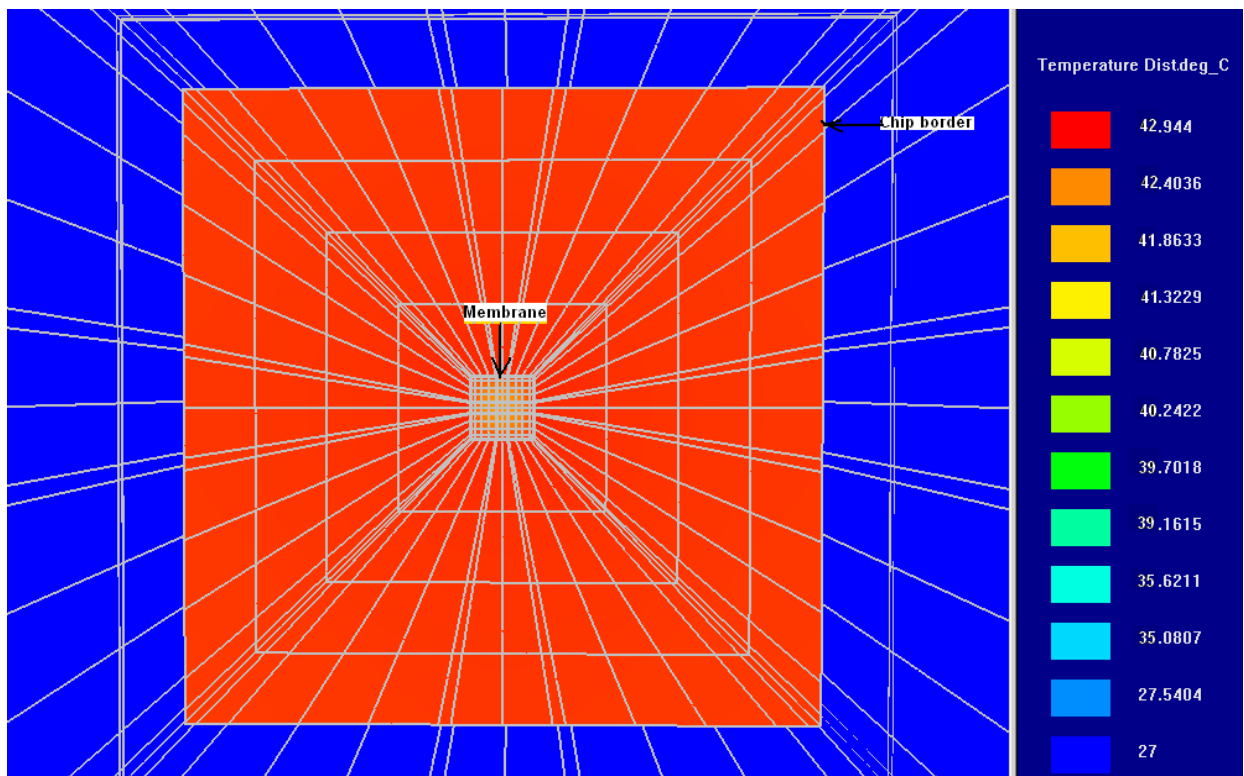

Fig.2b Temperature distribution with four piezoresistors

Initial temperature of the structure has been considered same as ambient. After application of electrical load in the form of potential difference across the piezoresistor of the structure and a pressure load of around 0.8bar, a steady state analysis has been performed. It is observed from Fig.2a and 2b that the steady state temperature rise is around 15⁰C for both the cases of single and four piezoresistors and there is negligible variation along the radial direction. This may be attributed to the fact that in a Wheatstone Bridge configuration of four piezoresistors, the electrical power in each of the piezoresistors become one-fourth when compared to the single piezoresistor with the same applied voltage and thus the total power dissipation of the four piezoresistors remain same as the single piezoresistor for a thermally conducting substrate like silicon.

2.2 Analytical model

We observe from Fig 2a and 2b of the finite element solution that the entire mass of the integrated chip gets heated up almost uniformly and we can consider one equivalent thermal time constant for the whole structure. Also a single piezoresistor in the center instead of four piezoresistors at the edges of the membrane can be considered for the analytical model. The thermal analysis of the integrated silicon pressure sensor can be greatly simplified with the following assumptions:

- Radiation losses from the upper and lower surfaces are neglected due to an expected low temperature difference between the membrane and ambient.
- The temperature distribution along the thickness of the membrane is neglected due to the high thermal conductivity of silicon which equalizes the temperature along the small thickness of the membrane almost instantaneously (validated by FEM analysis).
- The piezoresistor is considered to be of uniform temperature throughout because of its small size with respect to the membrane and high thermal conductivity of silicon due to its high doping (validated by FEM analysis).
- The package is considered at the ambient temperature which is true for most of the commercial metal packages.
- The heat transfer coefficients of the air surrounding the chip and through the packaging regions, are assumed to be independent of applied pressure. Actually for pressure sensor when the diaphragm bends due to increase/decrease of pressure, both airgap(δ) and thermal conductivity (K) may change. But the change in δ is only of the order of 1-2 μ m which is negligible compared to the original distance(δ) between the package and the chip . Hence the change in K due to variation of air pressure is negligible. Also significant change of K may occur only for pressure below 10 mtorr[14].

On the basis of the above simplifying assumptions the heat balance equation of the single piezoresistor pressure sensor packaged chip being subjected to a voltage V and pressure P may be expressed as:

$$\frac{V^2}{R_p} - (T - T_a)[R^2 h + (R^2 + 4(d_2 - d)R)h^* + (R_e^2 - R^2)(h + h') + 4d_2 R_e h] = ms \frac{dT}{dt} \quad (1)$$

where R_p is the resistance of the piezoresistor at a time instant t , m is the mass of the integrated sensor, s is the specific heat of silicon, T is the average temperature of the chip, h is the equivalent heat transfer coefficient of the air surrounding the silicon membrane within the package, h' is the heat transfer coefficient through the sealing material between the bottom surface of the bulk silicon and the package and h^* is the heat transfer coefficient through the air trapped between the bottom of the membrane and the sealing material. We have ignored the minor variation in the specific heat of different silicon regions of integrated pressure sensor chip. The left hand side denotes the heat stored in the system after considering the losses from the upper, lower and side surfaces of the integrated sensor through surrounding air and the packaging material and the right hand side denotes the temperature rise in the system.

In this equation, R_p is a function of temperature and pressure. On increase in temperature, the output of the pressure sensor drifts due to the change in the resistance of the piezoresistor which is again caused by : (a) change in resistivity of the p-type semiconductor and (b) change in piezoresistive coefficient.

For the change in the resistivity with temperature, the changed resistance of the piezoresistor is given by:

$$R_p = R_{p0} (T_2/T_1)^{3/2} \quad (2)$$

where T_1 and T_2 are the initial and final temperatures respectively and R_p and R_{p0} are the original and the changed value of resistance of the piezoresistor respectively. The changed value of resistance takes into account the change due to mobility only with temperature since the doping concentration of the p-type semiconductor is above 10^{15} atoms/cc resulting in negligible change in carrier concentration with temperature [15].

The initial value of the resistance R_{p0} obtained from fabrication is given by [15]:

$$R_{p0} = (1/en\mu)l/(wt_p) \quad (3)$$

where e is the electronic charge, n is the doping concentration, μ is the mobility of holes [15] at temperature T_1 , l is the length of the piezoresistor, w is the width of the metal contacts and t_p is the thickness of the piezoresistor determined by the junction depth.

On application of pressure, the changed resistance R_p' is given by :

$$R_p' = R_p (\sigma_l \pi_l (1 + \beta(T_2 - T_1)) + \sigma_t \pi_t (1 + \beta(T_2 - T_1)) + 1) \quad (4)$$

where π_l and π_t are the longitudinal and transverse coefficients respectively [16], β is the temperature coefficient of piezoresistance and is negative and is reported to be identical for both the coefficients [16] σ_l and σ_t are the longitudinal and transverse stresses respectively which are dependent on applied pressure and membrane dimensions [16]. β is typically of the order of $-0.0032/^\circ\text{C}$. The values of piezoresistive coefficients are taken from [17] for computing the changed value of resistance. Thus the overall resistance (R_p') at a particular temperature T_2 and pressure is given by:

$$R_p' = R_{p0}(T_2/T_1)^{3/2}(\sigma_l\pi_l(1 + \beta(T_2 - T_1)) + \sigma_r\pi_r(1 + \beta(T_2 - T_1)) + 1) \quad (5)$$

To estimate the rise in temperature with time, equation 1 has been solved numerically using equation 5 to compute the elemental change in resistance after small increments of time. Fig.3a shows the temperature rise for two different dimensions (R_e) of the integrated chip considering $h=h'$ with and without pressure and Fig.3b shows the temperature rise for the same dimensions of R_e of the integrated chip for a fixed value of $h=h^*=10$ and varying h' with and without pressure. We observe from figure 3a and Fig.3b that the temperature rise depends significantly on the value of the heat transfer coefficient. The value of h depends on the surrounding atmosphere namely the size, shape and material of the package [18] and the material between the surface of the sensor and the package. It is also dependent on the flow of the surrounding air. For values of h' greater than h which is true for most commercial packages, the temperature rise is smaller than that of the case when it is surrounded by air or air equivalent material on all sides as observed from Figures 3a and 3b. This is primarily due to the fact that the conductive heat loss from the back surface of the integrated chip is more in presence of other sealing material than when air is present. In our case, the air gap on all the three sides are maintained at 2.5mm and a 200 μ m Teflon film has been placed between the bulk micromachined side and the package with a hole below the membrane. This makes the value of h equal to 10 since $h=K/\delta$ where K is the thermal conductivity of air which is 0.024W/mK with a thickness δ of 2.5mm. The value of h' becomes equal to the ratio of the thermal conductivity of Teflon to its thickness which is 0.0027W/mK[19]/200 μ m and is approximately 10. Thus the values of h and h' are equal to 10W/m²K in our packaged sensor. It is also observed from Figs.3a and 3b that under an applied pressure of 0.8bar, the rise in steady state temperature decreases slightly.

Fig.4 shows the transient temperature rise for different dimensions of the integrated chip and $h=h^*=h'=10$ under a pressure of 0.8 bar. It is observed from Fig. 4 that the time constant is greater for larger dimension of the integrated chip implying that for larger dimension of the chip, the time taken to reach the steady state temperature is more because of greater thermal mass.

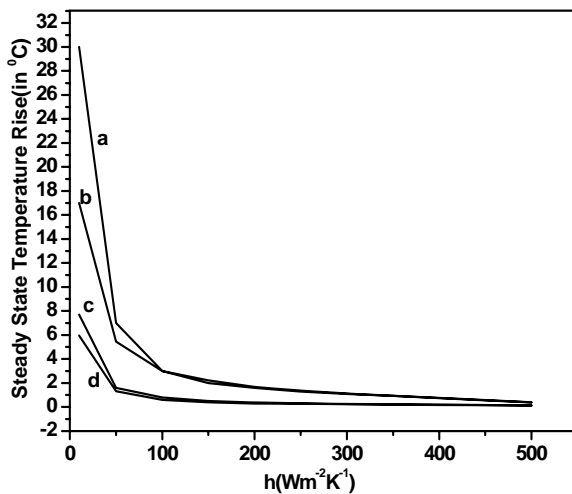

Fig.3a Variation of steady state temperature rise with h for

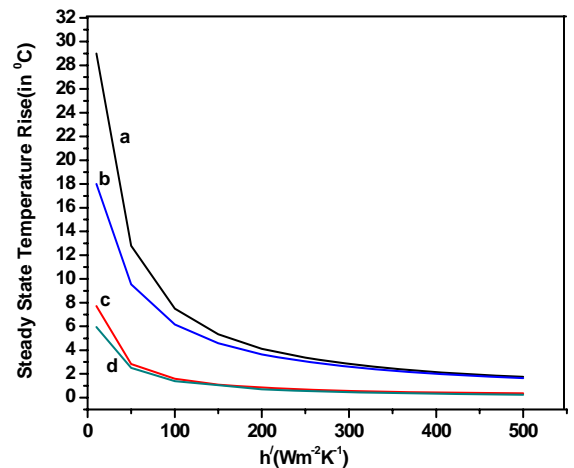

Fig.3b Variation of steady state temperature rise with $h=10$ and varying h' for different dimensions of the chip (a) 5.6mm

different dimension of the chip assuming $h=h'$ (a) 5.6mm by 5.6mm without pressure (b) 5.6mm by 5.6mm with pressure and (c) 10mm by 10mm without pressure (d) 10mm by 10mm with pressure

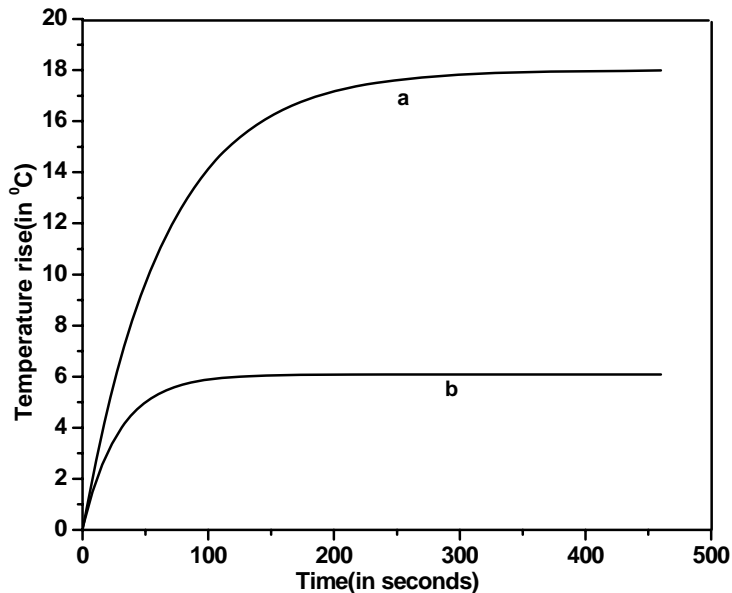

Fig.4 Transient response of integrated sensor for (a) 5.6mm by 5.6mm chip and (b) 10mm by 10mm chip

2.3 Validation of the analytical solution through experiment

For validation of the analytical model with the experimental results, a measurement setup has been established as shown in Fig 5 to characterize the thermal effects of the sensor chip placed within a laboratory made metal enclosure with a removable cover with an air gap of around 2.5mm between the metal cover and the chip on all the three sides. A Teflon film is placed for electrical insulation between the bulk micromachined side and the metal enclosure with a hole below the membrane. Gold wires are bonded from the sensor to the package by the Kulicke and Soffa Model no.4523A0. Differential pressures were produced in the experiment by connecting the hole in the Teflon sheet to a vacuum pump by a rubber tube. The tube can be evacuated and held at any desired pressure between one bar and zero by means of a controlled leak. The pressure was measured with a mercury manometer. The electrical excitation is provided by a Keithley source (Model 617) and the temperature is measured by an optical pyrometer by opening the removable cover. After the electrical excitation is provided, the metal cover is removed after a few minutes when the steady state temperature has reached and the temperature of the chip is then immediately measured by the optical pyrometer. During the measurement, there is no significant error since the time taken to reach a new thermal equilibrium due to the small opening of the cover is typically large compared to the measurement time.

The picture of the piezoresistive pressure sensor fabricated in the laboratory is shown in Fig.6a

and 6b. Four piezoresistors had been fabricated on membrane with lateral dimensions 1mm by 1mm and 20 μm thickness respectively as shown in Fig.6a. The dimensions of each piezoresistors are 200 μm by 50 μm as shown in Fig.6b with a sheet resistance of 250 Ω . Typical value of the piezoresistor obtained after fabrication in steady state is 1k Ω . The lateral dimension of the entire chip is about 10mm by 10mm and thickness of the chip is 500 μm . A voltage of 5V has been applied across the piezoresistors on the membrane and the differential pressure value has been set at 1bar after the steady state temperature has been attained. The value of the temperature is observed throughout the sensor chip at steady state with an applied differential pressure of 0.8bar and is plotted in Fig.7. It is observed that the experimental temperature changes matches well within 2% with the theoretical analysis which validates our assumptions in the analytical solution.

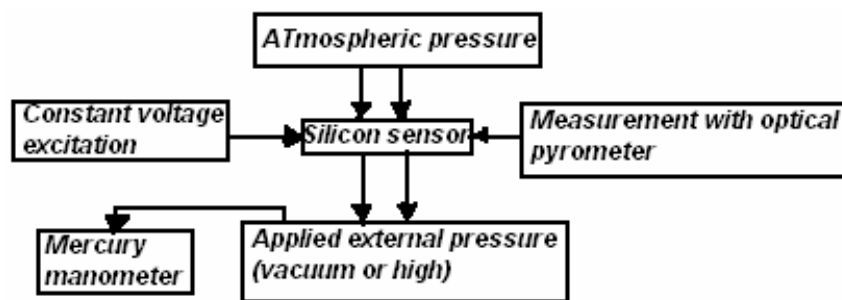

Fig.5 Block diagram of the measurement setup

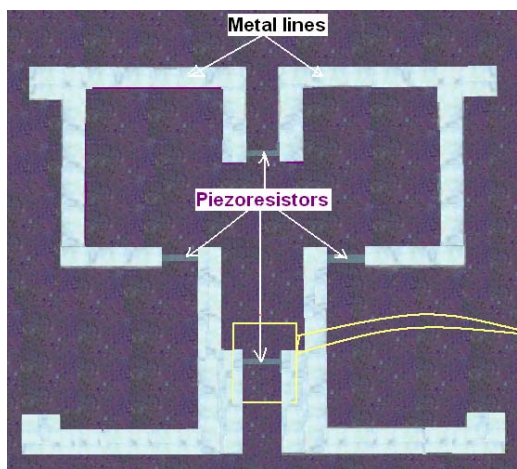

Fig 6a Photograph of the fabricated piezoresistive pressure sensor(magnification is 25 times)

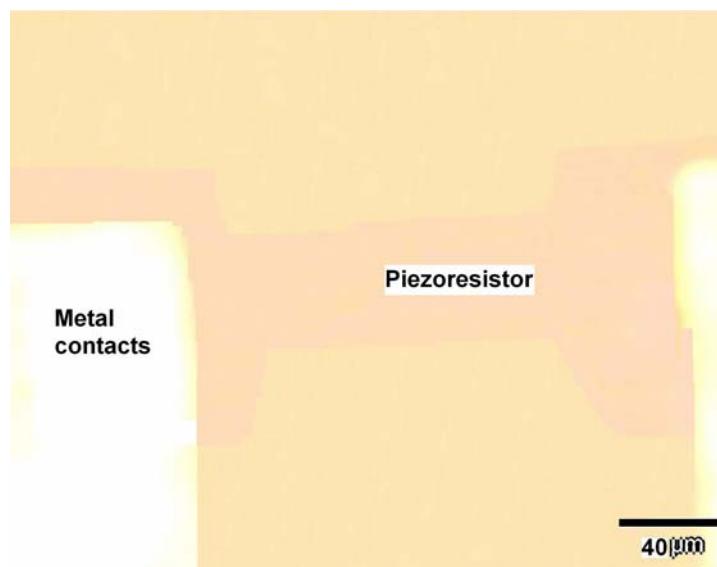

Fig. 6b Magnified picture of a single piezoresistor

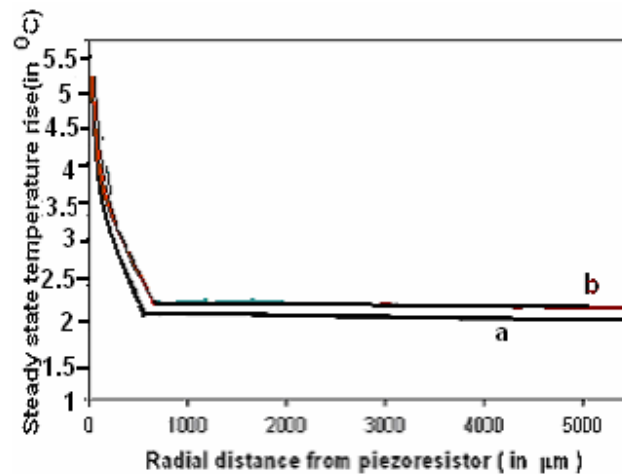

Fig.7 Radial distribution of temperature for 10mm by 10mm chip dimension (a) theoretical (b)experimental

3. INTEGRATION WITH CMOS

3.1 Coupled circuit and mechanical simulator

The analytical results obtained from the thermal analysis in Section 2 is validated with experimental results and finite element CAD tools so that the analytical thermal model can be coupled with the SPICE simulator to consider its effects on the CMOS circuit. It has been observed from the analysis that the temperature rise due to thermal effects at the edge of the membrane and in the chip may be quite significant depending upon packaging materials and dimensions of the chip and need to be incorporated in the simulation of the MOS circuits. To do so, we have coupled the analytical relationships with the MOS BSIM level3 device library to include the thermal effects in the MOS characteristics. The numerical computation such as those developed in this work are used for this coupling since otherwise, a data exchange programme software[18] interfacing the existing MEMS software and the T-SPICE simulator need to be developed which is a much more involved process.

In the commonly available MOS library, the ambient temperature effect which is normally considered through the statement “*double temp = model -> sim_data[SIM_TEMPERATURE] + KELVIN*” is now modified to “*double temp=f(model->R,R_e model->d,d₂ model->V...)+KELVIN*”[20] to incorporate the effects of electrical heating of piezoresistive pressure sensor. The function f is essentially the solution of the numerical computations of equations 1 and 5. Thus a new library called PIEZOTHERMOMOS (PTMOS) is created and is included in the library of the SPICE CAD tool which incorporates the effect of the electrical heating of the piezoresistor in MOS characteristics through the function f . During the call of the PTMOS library from the SPICE netlist, the different pressure sensor design parameters present in the model parameter definition structure like the piezoresistor dimensions, applied voltage, chip and membrane dimensions are passed from the netlist itself along with the MOS design parameters to obtain the desired characteristics including the thermal effect. This happens through the dynamic linked library facility of T-SPICE.

The input to the PTMOS amplifier is the voltage developed across the Wheatstone Bridge configuration of piezoresistors. The output voltage of the Wheatstone Bridge after the temperature rise due to electrical heating is given by equation 6:

$$dV = V * R_{p0} (T_2/T_1)^{3/2} (\sigma_l \pi_l (1 + \beta(T_2 - T_1)) - \sigma_t \pi_t (1 + \beta(T_2 - T_1))) / R_{p0} (T_2/T_1)^{3/2} \\ = V * (\sigma_l \pi_l (1 + \beta(T_2 - T_1)) - \sigma_t \pi_t (1 + \beta(T_2 - T_1))) \quad (6)$$

where dV is the change in the output voltage.

This voltage depends on the MEMS piezoresistor design parameters and thus a separate library for the equivalent resistance of the piezoresistor including its temperature dependence obtained from equations 1 and 5 is also called during the circuit analysis.

The operation of the coupled TSPICE simulator is explained in Fig 8. The T-SPICE simulator first calls the library of the piezoresistors to assign an equivalent electrical element in the circuit. In this case it is a resistor of certain value in place of a piezoresistor in the circuit. For computation of the piezoresistor value, the piezoresistor design parameters, input pressure, the membrane and chip dimensions are passed from the netlist itself. A voltage is applied across the Wheatstone bridge configuration of four piezoresistors and the voltage at the output terminals are given as input to the MOS amplifier circuit. While simulating the amplifier, the MOS model file corresponding to the new PTMOS library has to be included through a “*include*” statement [20]. This technique can be applied to the development of other integrated sensors with mixed signal design like SMART gas sensors [21].

3.2 Simulation Results of the PTMOS amplifier

The co-design of the PTMOS amplifier and the MEMS piezoresistor has been carried out for a high precision measurement for monitoring the pressure in the oceanic environment. The typical specifications of the pressure sensors for such an application are [22]:

- i) Pressure range: 0 to 1 bar
- ii) Resolution: 0.0001% of full scale
- iii) Non-Linearity: 0.001% of full scale

To achieve the above resolution, a minimum of 0.05mbar is to be sensed. For such precision applications, it is necessary to design a low noise chopper stabilized amplifier with a high gain. To obtain a low input referred noise, chopper stabilized amplifier is reduced in which a chopping frequency of around 100 kHz is used to reduce the flicker noise. The schematic of the chopper-stabilized scheme is shown in Fig.9 [23]. A typical gain required to meet the specifications in the low-pressure range is 625[22]. The output of the amplifier integrated with a pressure sensor having piezoresistor dimensions 200 μ m by 50 μ m, lateral dimensions 1mm by 1mm and thickness 20 μ m and total chip dimensions of 5.6mm by 5.6mm, when subjected to various pressures, are computed from the coupled simulator using 0.35 μ m MOS technology and are displayed with and without incorporating the thermal effects in Fig.10.

To obtain the output of the amplifier without including thermal effects, the numerical program based on equations 1 and 5 is executed only for the first interval of time for different values of pressure. To illustrate the thermal effect for high precision measurement, we have simulated the

integrated pressure sensor with a suitable packaging material to yield $h=h^*=10$ and $h'=400$ so that the steady state temperature rise is only 2°C . It is observed from Fig.10 that the output of the integrated pressure sensor corresponding to a pressure of 1 bar changes from 3.3V to about 3.27V i.e. by 0.9% due to thermal effects which is quite significant since to measure a minimum change in pressure of 0.05mbar at 1 bar level, the output voltage changes only by 0.004%. This large change(0.9%) in the output that is partly due to the change in the offset voltage of the piezoresistor and partly due to the change in the MOS characteristics caused by increased temperature arising from self heating of piezoresistors should be taken into account in the design of compensation circuits for high precision measurements.

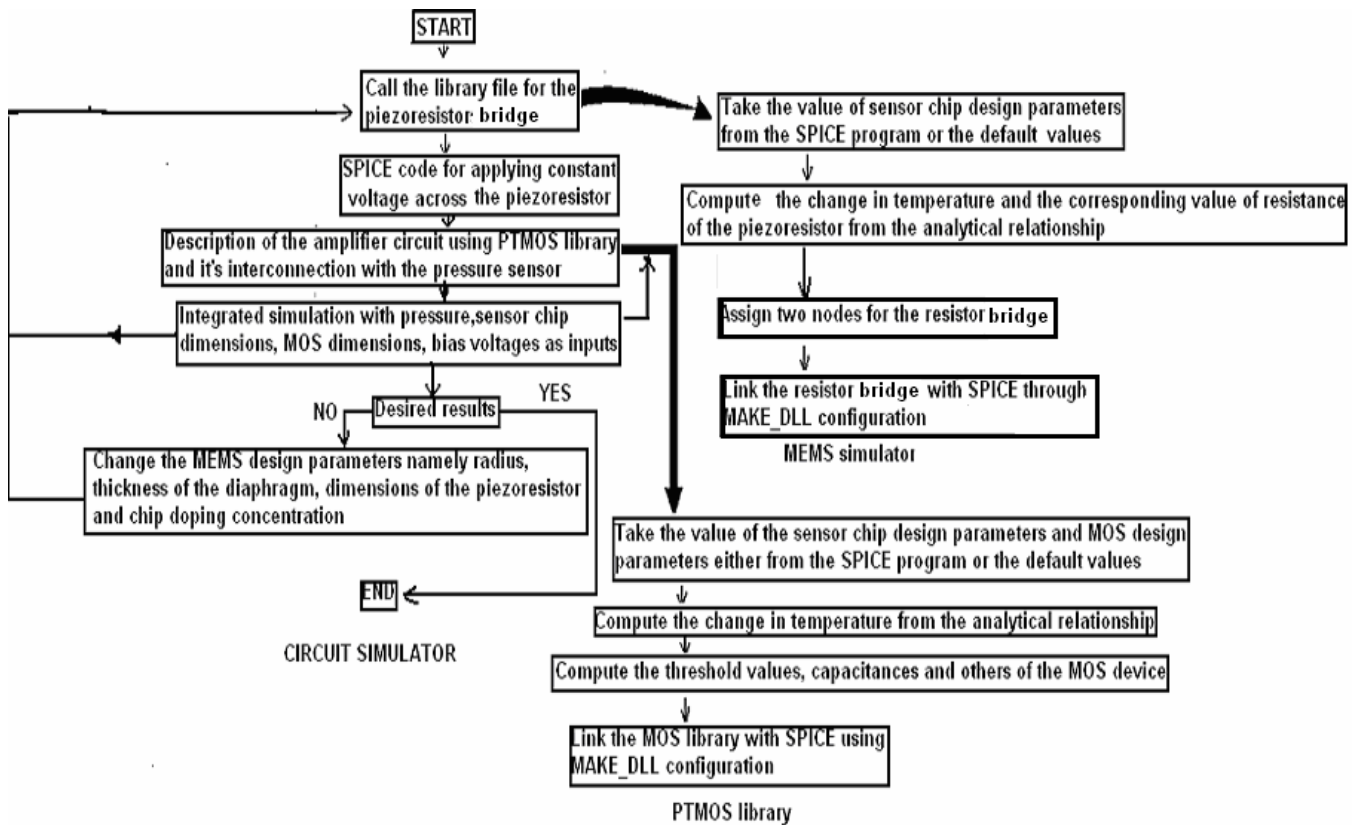

Fig 8 Coupling of PTMOS and piezoresistor library with SPICE simulator

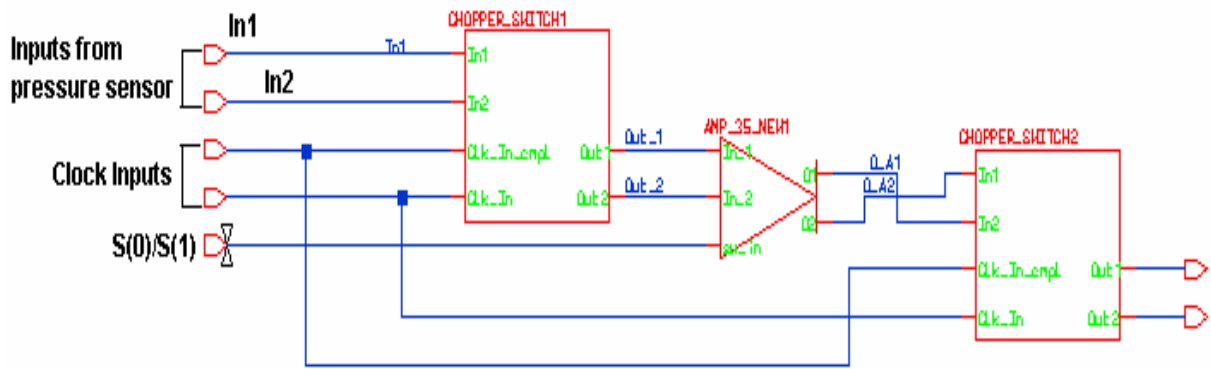

Fig.9a Schematic of the chopper stabilized amplifier

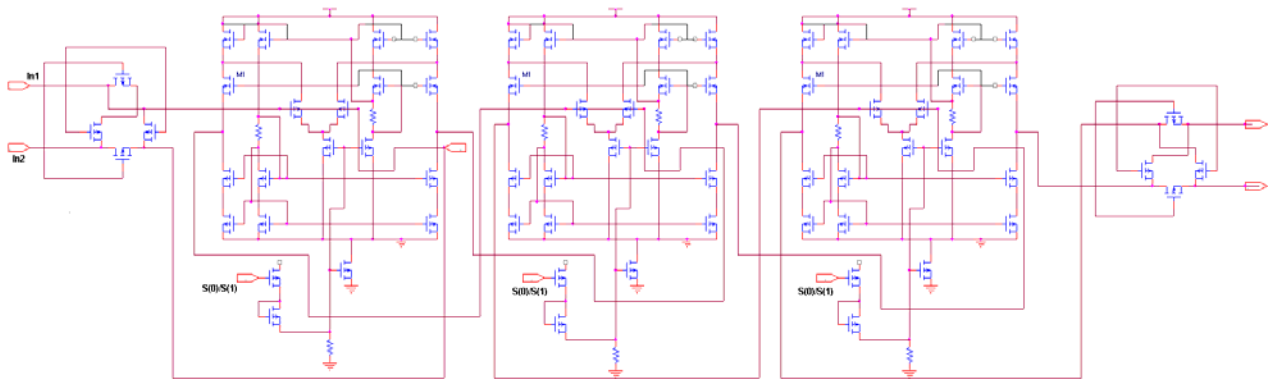

Fig.9b Schematic of the open loop two stage CMOS OPAMP

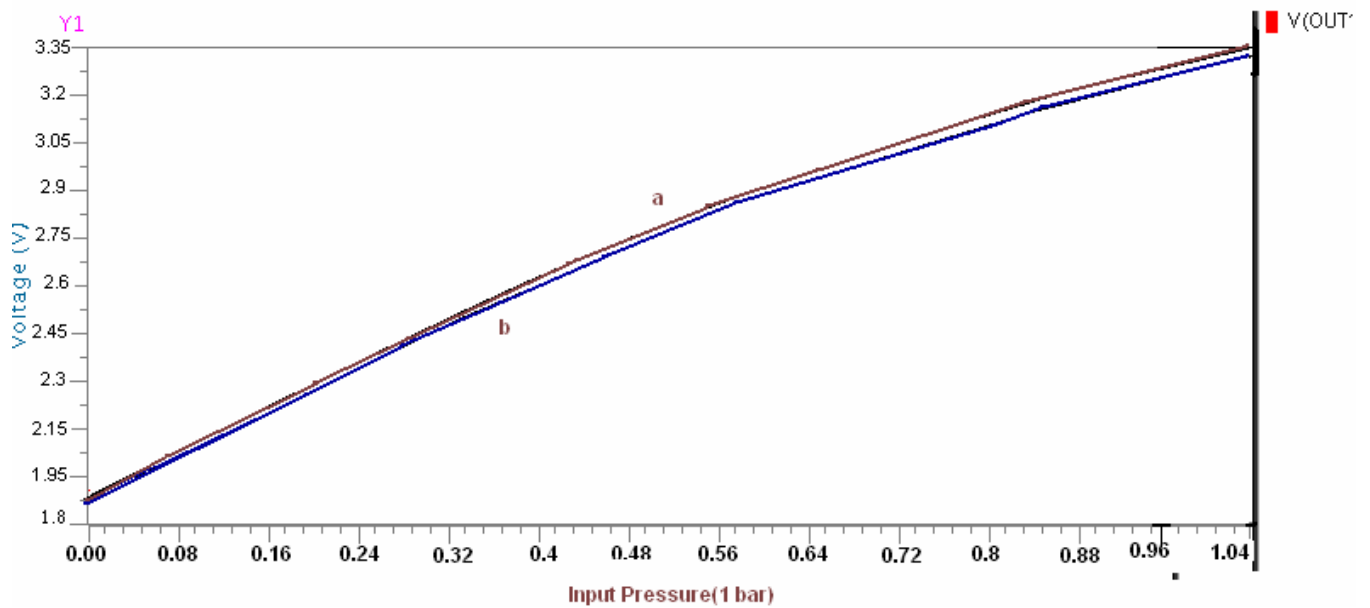

Fig.10 Simulated Output of amplifier using the coupled simulator (mentor graphics) (a) without and b) with thermal effects consideration

4. CONCLUSION

In this paper we have proposed a simple analytical model for estimating quantitatively both the steady state and transient thermal effects of an integrated packaged MEMS piezoresistive pressure sensor on the basis of the results obtained from FEM analysis and matched the results experimentally by fabricating pressure sensor and the relevant packaging in the laboratory. The effect of packaging materials and the dimensions of the chip are taken into account in the analysis. The analytical solutions which relate the change in temperature with the various dimensions of the integrated chip and the membrane as well as the packaging and the input power are then incorporated directly in the CMOS library tools to study the thermal effects of the MEMS sensor on the integrated CMOS MEMS sensor unit. A new interfacing library of MOS called PIEZOTHERMOMOS (PTMOS) has been developed for this purpose which incorporates the change in temperature due to self heating. The changed voltage output of the Wheatstone Bridge configuration of piezoresistors due to self heating is then incorporated in the T-SPICE through the dynamically linked library of the piezoresistor bridge. It is observed that for a sensor typically packaged with a thin Teflon sealing having piezoresistor dimensions of 200 μm by 50 μm , membrane dimensions of 1mm by 1mm and 20 μm thickness and total chip dimensions of 5.6mm by 5.6mm and 500 μm thickness, the temperature rise of the chip in air is around 18 $^{\circ}\text{C}$ and for a commonly used sealing material it is around 2 $^{\circ}\text{C}$. As a result of a temperature rise of 2 $^{\circ}\text{C}$, the output of the amplifier undergoes a change of around 0.9% due to thermal effect whereas the change due to 50mbar pressure is around 0.004% only, thus indicating the importance of thermal effects. Thus this integrated analysis will help in proper selection of the dimensions and packaging of the integrated CMOS MEMS sensor chip to improve the precision of pressure measurement with considerable reduced design time.

ACKNOWLEDGEMENTS

The authors would like to acknowledge AICTE, Govt. of India for the financial support required to carry out the work and Dr.Utpal Gangopadhyay for help in fabricating the pressure sensor in the laboratory.

REFERENCES

- [1] S.Marco, J.Samitier, O.Ruiz, J.Morante, J.E.Steve, "High performance piezoresistive pressure sensors for biomedical applications using very thin structured membranes", *Meas. Sci. and Technol.*, vol.7, pp.1195-1203,1996
- [2] C.Pramanik, H.Saha, "Piezoresistive pressure sensing by porous silicon membrane", *IEEE Sensors*, vol.6, p.301,2006
- [3] Sugiyama, S., K. Kawahata, M. Yoneda, and I. Igarashi, "Tactile Image Detection Using a 1K-element Silicon Pressure Sensor Array." *Sensors and Actuators*. A21-A23:397-400, 1990.
- [4] J.Borky, K.Wise, "Integrated signal conditioning for silicon pressure sensors", *IEEE Trans on Electron Devices*,vol.26, pp.1906-1910, 1979
- [5] Honeywell Precision Barometer(HPB/HPA)
- [6] www.sensiron.com(SDP1000/SDP2000)

- [7] K.S.Henriksen, D.T.Wang, H.Rogne, A.Ferber, A.Vogl, S.Moe, R.Bernstem,D.Lapadatu, K.Sandvar and S.Brida, “High Resolution pressure sensor for photoacoustic gas detection”, *Sensors and Actuators A*, vol.132, pp.207-213, 2006.
- [8] K.Arshak, D.Morris, A.Arshak, O.Korostynska, E.Jafer, D.Waldron,J.harris, “Development of polymer based sensors for integration into a wireless data acquisition system suitable for monitoring environmental and physiological processes”, *Biomolecular Engg.*, vol.23, pp.253-257,2006.
- [9] O.Barnd, G.K.Fedder edited *Advanced Micro and NanoSystems vol.2, CMOS-MEMS*, Wiley-VCH,2005
- [10] C.Pramanik, T.Islam, H.Saha , “Impact of self heating in a silicon MEMS piezoresistive pressure sensor”, *Sensor Letters*, vol.2, pp.131-137,2004.
- [11] Y.C.Sun, Z.Gao, L.Qiang, Y.Zhang, “Modelling of the reverse current and its effects on the thermal drift of the offset voltage for piezoresistive pressure sensors”, *Sensors and Actuators A*, vol.116, pp.125-132, 2004.
- [12] Aljancic, U.; Resnik, D.; Vrtacnik, D.; Mozek, M.; Amon, S., “Temperature effects modeling in silicon piezoresistive pressure sensor”, *11th Mediterranean Electrotechnical Conference, 2002*, pp.36-40.
- [13] K.Birkelund, P.Gravesen, S.Shiryayev, P.B.Rasmussen, M.D.Rasmussen, “High pressure silicon sensor with low-cost packaging”, *Sensors and Actuators A*, vol.92, pp.16-22, 2001.
- [14] Kerry Cheung, “Modeling a MEMS Thermal Conductivity Pressure Sensor for the Evaluation of Glass Frit Vacuum Packaging”, *Journal of Nano-to-Macro Energy Transport (JNET)*, 2004.
- [15] S.M.Sze, *Physics of Semiconductor Devices*, Wiley Publishers, 1998.
- [16] K.Matsuda, K.Suzuki, K.Yamamura, Y.Kanda, “Nonlinear piezoresistance effects in silicon”, *J.Appl.Phys.* ,vol. 73(4), p.1838, 1993.
- [17] O. N. Tufté and E. L. Steizer, "Piezoresistive properties of silicon diffused layers", *J. Appl. Phys.* vol.34. 313-18 , 1963
- [18] H.S.Carslaw, J.C.Jaeger, “*Conduction of Heat in Solids*”, Oxford UK 1959
- [19] www.yutopian.com/Yuan/prop/Teflon.html
- [20] T.L.Quarles, “*The SPICE3 Implementation Guide*” Electronics Research Laboratory, University of California, Berkeley, CA, 1989
- [21] G. C. Cardinali, L. Dori, M. Fiorini, I. Sayago, G. Faglia, C. Perego, G. Sberveglieri, V. Liberali, F. Maloberti and D. Tonietto, “A Smart Sensor System for carbon Monoxide Detection”, *Analog Integrated Circuits and Signal Processing*, vol.14, pp.275-296,1997.
- [22] C.RoyChaudhuri, V.Natarajan, P.Chatterjee, S.Gangopadhyay, V.Sreeramamurthy, H.Saha, “Design of A High Performance MEMS Pressure Sensor Array With Signal Conditioning Unit For Oceanographic Applications”, to be published in *Sensors and Transducers journal*.
- [23] Anton Bakker, Kevin Thiele, and Johan H. Huijsing, “A CMOS Nested-Chopper Instrumentation Amplifier with 100-nV Offset”,*IEEE J. of Solid State Circuits*, vol.35, no.12, 2000, p.1877