

A Design of Gain-scheduled Congestion Controllers using State Predictive Observers

Takehito Azuma* and Masashi Uchida**

*Utsunomiya University, 7-1-2 Yoto, Utsunomiya 321-8585, JAPAN

**HOKUSHO Co., Ltd., Shino-machi, Kanazawa, JAPAN

Email: tazuma@cc.utsunomiya-u.ac.jp

Abstract- In this paper, a design problem of congestion controllers is discussed for TCP/AQM(Transmission Control Protocol/Active Queue Management) networks. The proposed method consists of two control techniques. First one is based on a gain-scheduling technique considering nonlinearities of TCP/AQM networks. But the designed congestion controller is a state feedback controller and it is impossible to embed the congestion controller in real computer networks. To avoid this problem, second one is based on a design technique of state predictive observer for linear time-delay systems. Thus it can be possible to embed the congestion controller in real networks by combining these methods. Firstly dynamical models of TCP/AQM are described as linear systems with self-scheduling parameters, which also depend on information delay. Here it is distinguishing to focus on constraints on the maximum queue length and TCP window-size, which are the network resources in TCP/AQM networks. And a design method of memoryless state feedback controllers is shown for linear system with a self-scheduling parameter and an information delay. But the designed gain-scheduled congestion controller is a state feedback controller and it is impossible to apply this controller to computer networks directly. Thus observers are also designed and the observer-based congestion controllers are derived.

Index terms: congestion control systems, networking, TCP/AQM networks, gain-scheduling, state predictive control-

I. INTRODUCTION

Computer networks or wireless networks have become main communication tools. Especially the high reliable exchange of data using the Internet has been important for its explosive growth and utilization. The Transmission Control Protocol, which is called TCP, is well known as this

exchange. Under TCP, a window flow-control mechanism is used to set its transmission rate (Figure 1). In this mechanism, TCP increases the window size during successful data transmission. Conversely TCP cuts the window size in half whenever a data does not reach the receiver. Such data losses called "packet losses" can affect network performance. One of causes of this is that TCP has no information of network mechanisms contributing to packet loss [1][2][3]. Considering this, recently TCP/AQM (Transmission Control Protocol /Active Queue Management) networks having queue information of the congested node are considered in some papers [4][5][6][7]. Other papers considering congestion control are about scalable control [8] [9] [10].

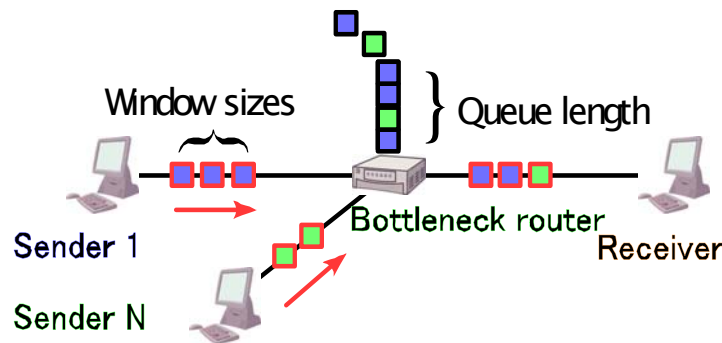

Figure 1. Congestion in computer networks

Some kinds of AQM schemes are proposed, e.g. Random Early Detection (RED) [11][12], Virtual Queue [13], Random Early Marking (REM) [14], Adaptive Virtual Queue (AVQ) [15], Proportional Integral Controller [16], Gain-scheduled Controller [20][21] and Robust State Predictive Controller [26]. Based on the control theory, it seems possible to design that congestion controllers (AQM schemes) achieve better performances than those AQM schemes do. AQM design problems are important and become useful in future researches because AQM is embedded in the router having much information about circumstances of current networks.

In this paper, a design method of congestion controllers is proposed for TCP/AQM networks. The proposed method consists of two congestion control approaches. First approach is the gain-scheduled control [20][21] based on gain scheduling techniques [17][18]. This controller is a state feedback controller but can achieve good performances and consider nonlinearities of TCP/AQM networks. Second one is based on the robust state predictive controller [26]. This approach is based on linearized systems of TCP/AQM networks but it is possible to design

observers for TCP/AQM networks. In [26], the efficacy of the designed observers is shown. Thus it seems possible to design good congestion controllers by combinations of these two approaches. In the numerical example, the effectiveness of the proposed method is evaluated by using *ns-2* (Network Simulator Ver.2) by comparing the result of [26] and the proposed approach.

II. GAIN-SCHEDULED CONGESTION CONTROL

In this section, a design method of gain-scheduled congestion controllers [20][21] is summarized. Firstly dynamical models of TCP/AQM networks considered in this paper are shown. The dynamical models of TCP/AQM networks consist of models of the TCP window sizes, queue lengths and AQM mechanisms. Models are described as nonlinear equations but the dynamical models of TCP/AQM networks can be derived as linear systems with self-scheduling parameters and time delays which we call as information delay.

● Dynamical models of TCP/AQM networks

Dynamics of TCP networks:

Dynamical models of TCP were investigated by [22] [23]. The dynamical models of TCP networks are given as the following nonlinear differential equations.

$$\dot{w}_s(t) = \frac{1}{h_r(t)} - \frac{w_s(t)}{2} \frac{w_s(t-h_r(t))}{h_r(t-h_r(t))} p(t-h_r(t)) \quad (1)$$

$$\dot{q}(t) = N(t) \frac{w_s(t)}{h_r(t)} - C \quad (2)$$

where w_s is the average TCP window size, q is the average queue length, C is the queue capacity, N is the number of TCP sessions and p is probability of packets dropped at AQM. h_r is round-trip time $RTT = \frac{q}{C} + T_p$ (T_p : propagation delay).

This parameter h_r is information delay in TCP networks. We also assume that w_s and q are constrained as follows,

$$q \in [0, q_{\max}], \quad (3)$$

$$w_s \in [0, w_{s\max}]. \quad (4)$$

In the equation (1), the parameter p is very important. In case of $p=0$, (1) is equal to the first term. This dynamics denotes that TCP window size increases linearly. On the other hand, in case

of $p=1$, (1) is equal to the second term. These facts mean that the TCP window size decreases largely. Thus it is important to change the TCP window size by setting p adequately to avoid congestions in networks but traditional AQM designs are impossible to change the TCP window size by setting p adequately because parameter tunings of AQM schemes, which are explained in the next subsection, are manual procedures.

AQM scheme:

Active queue management is a core process where packets are dropped depending on the queue length. Dropped packets in this way amounts to reducing TCP source rate as the queue length grows. The objective of AQM is to manage the buffer size as a mean value (the average queue length).

In equations (1) (2), the average queue length can be adjusted by the TCP window size. Thus it is proper to avoid congestions that we make the TCP window size small if the average queue length is large. It is also proper to achieve effective data transmission that we make the TCP window size large if the average queue length is small. In this paper, our objective is to design AQM scheme that has the above properties.

- Representation as linear systems with self-scheduling parameters and information delays

Here we derive dynamical models of TCP/AQM networks as linear systems with self-scheduling parameters and information delays. To simplify the discussion, we assume that the number of TCP sessions and round-trip time (information delay) are time invariant, e.g.

$$N(t) = N, h_r(t) = h_r.$$

If $w_s \gg 1$ [16], the dynamical model of TCP/AQM networks (1) (2) can be described as follows,

$$\dot{w}_s(t) = \frac{1}{h_r} - \frac{w_s(t)^2}{2h_r} p(t - h_r), \quad (5)$$

$$\dot{q}(t) = N \frac{w_s(t)}{h_r} - C. \quad (6)$$

Introducing the equilibrium points (w_{so}, q_o, p_o) which are given by

$$p_o = \frac{2}{w_{so}^2}, w_{so} = \frac{h_r C}{N}, \quad (7)$$

equations (5) and (6) become

$$\delta \dot{w}_s(t) = -p_o \frac{\delta w_s(t) + 2w_{so}}{2h_r} \delta w_s(t) - \frac{(\delta w_s(t) + 2w_{so})^2}{2h_r} \delta p(t - h_r), \quad (8)$$

$$\delta \dot{q}(t) = N \frac{\delta w_s(t)}{h_r}, \quad (9)$$

where the following conditions are satisfied,

$$w_s(t) = w_{so} + \delta w_s(t),$$

$$q(t) = q_o + \delta q(t),$$

$$p(t) = p_o + \delta p(t).$$

Now the state variable and the input variable are introduced as follows,

$$x(t) = \begin{pmatrix} x_1(t) \\ x_2(t) \end{pmatrix} = \begin{pmatrix} \delta w_s(t) \\ \delta q(t) \end{pmatrix}, u(t) = \delta q(t).$$

Then TCP/AQM networks (5) and (6) (that is (1) and (2)) can be described as the following linear system with a self-scheduling parameter and an information delay.

$$\dot{x} = A(\theta_x(x))x + B(\theta_x(x))u(t - h_r) \quad (10)$$

$$\theta_x(x) = x_1(t) = \delta w_s(t) \quad (11)$$

where

$$A(\theta_x(x)) = A_0 + A_1\theta_x(x),$$

$$A_0 = \begin{pmatrix} \frac{w_{so}}{h_r} & 0 \\ N & 0 \\ \frac{1}{h_r} & 0 \end{pmatrix}, A_1 = \begin{pmatrix} \frac{1}{2h_r} & 0 \\ 0 & 0 \end{pmatrix} \quad (12)$$

$$B(\theta_x(x)) = B_0 + B_1\theta_x(x) + B_2\theta_x(x)^2,$$

$$B_0 = \begin{pmatrix} \frac{1}{h_r} \\ 0 \end{pmatrix}, B_1 = \begin{pmatrix} \frac{v_{so}}{h_r} \\ 0 \end{pmatrix}, B_2 = \begin{pmatrix} \frac{v_{so}^2}{2h_r} \\ 0 \end{pmatrix} \quad (13)$$

and $\theta_x(x)$ is called as a self-scheduling parameter. From the above discussion, TCP/AQM networks are described as linear system with a self-scheduling parameter and an information delay (10)- (13) having constraints (3) and (4).

● A Design of State Feedback Gain-scheduled Controllers

Now consider the following linear time-delay system with a self-scheduling parameter (10), (11) where $x \in R^n$ is the state, $u \in R^m$ is the input and h_r is a constant time delay. $\theta_x(x)$ is a self-scheduling parameter and is equal to x_1 which denotes the first element of the state x . In this paper, we consider this simple case. Of course it is possible to extend more general case, but to

simplify the discussion we consider only a simple case. Additionally we consider the constraint of the state variable x as follows,

$$x \in X_e = \{x | x' Q_x^{-1} x \leq 1\}. \quad (14)$$

The matrix Q_x is a given matrix and denotes a constraint of the state variable x . Since the linear time-delay system with a self-scheduling parameter (10) is nonlinear, the constraint of the state variable x (14) is usual and meaningful. Thus the global problem of the linear time-delay system with a self-scheduling parameter is not discussed in this paper and only a semi-global problem is considered.

Now considering the state constraint (14), the linear time-delay system with a self-scheduling parameter can be treated as a linear parameter varying (LPV) system with a time delay as follows,

$$\dot{x} = A(\theta(t))x + B(\theta(t))u(t - h_r), \quad (15)$$

$$\theta(t) = [\theta_{\min}, \theta_{\max}]. \quad (16)$$

where $\theta(t)$ is the scheduling parameter of this LPV system with a time delay and $\theta_{\min}, \theta_{\max}$ are given from the constraint (14). We call this LPV system with a time delay as a linear time-delay system with a scheduling parameter.

Note that the system (10)-(13) includes the linear time-delay systems with a scheduling parameter (15) with (16). Here we define the design problem of stabilizing controllers for the linear time-delay system with a self-scheduling parameter (11).

Problem: Design the memoryless state feedback controller

$$u(t) = Kx(t) \quad (17)$$

which stabilizes the linear time-delay system with a self-scheduling parameter (10) with (11) and assures that the state of the closed loop system satisfies the constraint (14).

The following theorem can solve the problem defined in the previous subsection [20].

Theorem 1. Let θ_{\min} and θ_{\max} be given parameters. If there exist matrices $X > 0$, $P_1 > 0$, $P_2 > 0$ and Y such that the following two LMIs are feasible for all $\theta \in \Theta = [\theta_{\min}, \theta_{\max}]$,

$$\begin{array}{cccc} M_c & XA'(\theta) & Y'B'(\theta) & B(\theta)Y \\ \hline A(\theta)X & -P_1 & 0 & 0 \\ B(\theta)Y & 0 & -P_2 & 0 \\ \hline XB'(\theta) & 0 & 0 & -X \end{array} \succ 0, \quad (18)$$

$$X > P_1 + P_2, \quad (19)$$

where $M_c = h_c^{-1} [XA'(\theta) + A(\theta)X + Y'B'(\theta) + B(\theta)YQ]$ and moreover defining K , A_c and B_c as

$$K = YX^{-1},$$

$$A_c(\theta) = A(\theta) + B(\theta)K,$$

$$B_c(\theta) = B(\theta)K,$$

be using matrices of (18) and (19), if there exists

$\alpha > 0$ which satisfies

$$\begin{bmatrix} A_c Q_x + Q_x A_c'(\theta) + \alpha Q_x & B_c(\theta) \\ B_c'(\theta) & -2\alpha Q_x \end{bmatrix} < 0, \quad (20)$$

for all $\theta \in \Theta$.

Then the controller

$$u(t) = Kx(t), K = YX^{-1} \quad (21)$$

is a stabilizing controller for the system (10)-(13) and the state of the closed loop system satisfies the constraint (14).

Here a simple explanation of Theorem 1 is given. The first LMIs (18) and (19) assure that the closed-loop system (10)-(13) is asymptotically stable without considering the constraint (14). The next LMI (20) assures that the state of the closed-loop system satisfies the constraint (14).

Remark 1. Parameters θ_{\min} and θ_{\max} are design parameters and should be chosen adequately because conservativeness of the result from Theorem 1 is decided by these parameters. Usually θ_{\min} and θ_{\max} are obtained by considering the constraint (14) in case of a given matrix Q_x because the self-scheduling parameter $\theta_x(x)$ is equal to $x_1(t)$. The given matrix Q_x is an estimated matrix from a reachable set of the controlled system (10)-(13). The derived conditions are dependent on the parameter θ and it is needed to reduce finite dimensional conditions because the parameter dependent conditions are infinite and difficult to solve. But it is possible to reduce finite dimensional conditions using the technique [24][25].

III. DESIGN OF GAIN-SCHEDULED CONGESTION CONTROLLERS AND STATE PREDICTIVE OBSERVERS

State predictive control is applied to a design of congestion controllers for TCP/AQM networks [26] and it was shown that good performances are achieved in comparison with RED [11]. In this paper, gainscheduled congestion controllers with state predictive observers are proposed. This approach is combination of [20][21] and [26].

- Linearization of mathematical models for TCP/AQM Networks

To design state predictive observers, linearized models of nonlinear models introduced in the previous section are derived. Linearized models are given as the following linear system with an input time-delay

$$P(s) = \frac{\frac{C^2}{2N}}{(s + \frac{2N}{R_0^2 C})(s + \frac{1}{R_0})}, \quad (22)$$

where $R_0 = q_0 / C + T_p$.

Now the state variable and the input variable are introduced as follows,

$$x(t) = \begin{bmatrix} \delta q_s(t) \\ \delta q(t) \end{bmatrix}, y(t) = \delta q(t), u(t) = \delta p(t).$$

The state equation of the linear systems with an input time-delay is given as follows,

$$\dot{x}(t) = Ax + Bu(t - R_0), \quad (23)$$

$$y(t) = Cx(t), \quad (24)$$

$$A = \begin{bmatrix} -\frac{2N}{R_0^2 C} & 0 \\ \frac{1}{R_0} & 0 \end{bmatrix}, B = \begin{bmatrix} \frac{R_0 C^2}{2N^2} \\ 0 \end{bmatrix},$$

$$C = [0 \quad 1].$$

- State Predictive Observers

It is impossible to obtain the state of the above time-delay system directly because the controller is embedded in the bottleneck router and the TCP window size is not available on-line. The state $x(t)$ is estimated by using the following observer.

$$\dot{\hat{x}}(t) = A\hat{x}(t) + Bu(t - R_0) - L_p(y(t) - C\hat{x}(t)), \quad (25)$$

where L_p is an observer gain which is designed as $A + L_p C$ becomes stable. Considering an estimated error of the state $e(t) = x(t) - \hat{x}(t)$, the error system is given as follows,

$$\begin{aligned}
 \dot{e}(t) &= \dot{x}(t) - \dot{\hat{x}}(t) \\
 &= A(x(t) - \hat{x}(t)) + L_p C(x(t) - \hat{x}(t)) \\
 &= (A + L_p C)(x(t) - \hat{x}(t)) \\
 &= (A + CL_p)e(t)
 \end{aligned} \tag{26}$$

and it is possible to design observers if (C,A) is observable.

Now it is assumed that (C,A) is observable and the observer gain L_p is designed as a synthesis problems of a Kalman filter in case of considering that the small change of the input time delay is a white noise. The general description of linear systems with white noises is given as follows,

$$\begin{aligned}
 \dot{x}(t) &= Ax(t) + B_1 u(t) + B_2 \xi(t), \\
 y(t) &= Cx(t) + D_1 u(t) + D_2 \xi(t) + \eta(t),
 \end{aligned}$$

where $B_1 = B$, $B_2 = [w_{s0} * 2 \quad q_0 / 2]^T$, $D_1 = 0$, $D_2 = 0$, $E[\xi(t)\xi(t)^T] = 1$ and $E[\eta(t)\eta(t)^T] = 1$. B_2 denotes the small change of the input time delay. Finally the observer gain L_p is easily designed as a synthesis problem of a Kalman filter for this system by using MATLAB.

Remark 2: The closed loop system designed in the section 3 and 4 is shown in Figure 2. The block diagram in the dotted line denotes the designed controller which is embedded as AQM. Observers are designed by using the method in this section and the feedback gain K is designed in the previous section.

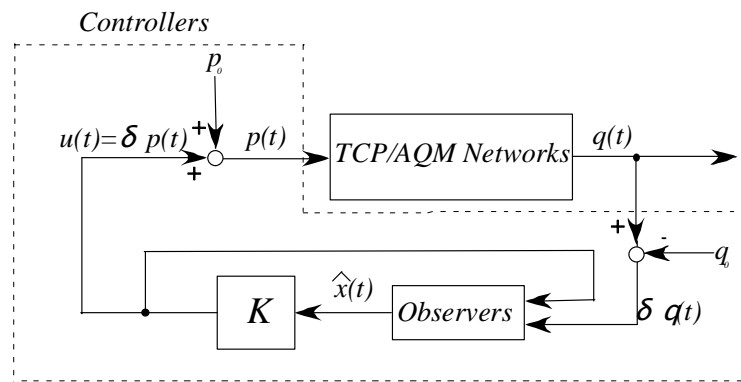

Figure 2. The closed loop system

IV. NS-2 SIMULATION

The network topology is in Figure 1 and parameters are given in Table 1. Simulation is done by using *ns-2*. Figure 3 shows the result in case of the gainscheduled congestion controller using the state predictive observer which is proposed in this paper. Figure 4 shows the result in [26]. Note that time axis is different from Figure 3 and Figure 4. Thus it is obvious that the time response of the proposed approach is very fast. From these results, the proposed approach can achieve better performances than the approach in [26], e.g. high initial responses and slow steady responses.

Table 1: Parameters of the network topology

Parameters	Value
A number of TCP sessions N	8
Information delay h_r	0.56 [s]
Propagation delay T_p	14[ms]
Link capacity C	73.3[packets/s]
Maximum window size $w_{s\max}$	8[packets]
w_{s0}	5.13[packets]
q_0	40[packets]
p_0	0.076

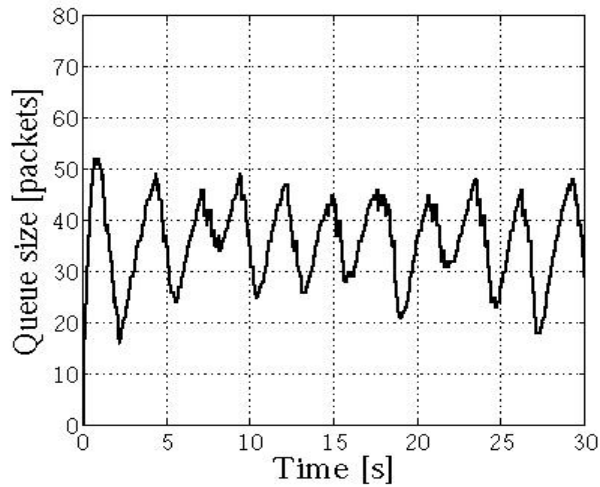

Figure 2: The queue size (the proposed method)

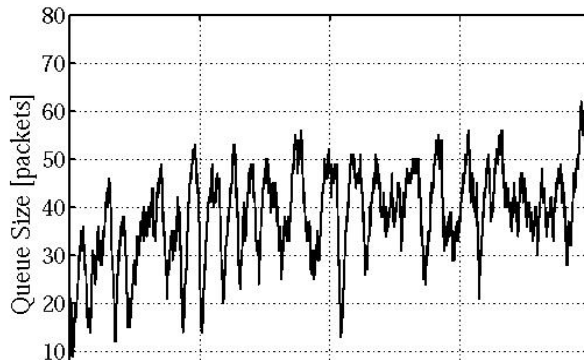

Figure 4: The queue size ([26])

VI. CONCLUSIONS

This paper has proposed a new AQM scheme that is based on robust congestion controllers. The proposed scheme consists of robust state feedback controllers and observers that is designed by using state predictive control approach. From a numerical example with the ns-2 simulator, it is shown that the proposed approach achieves better performances than previous one.

REFERENCES

- [1]S.Low, F.Paganini and J.Doyle, "Internet congestion control", IEEE Control Systems Magazine, 2002, pp 28-43
- [2]C.Jin, D.Wei, S.Low, G.Buhrmaster, J.Bunn, D.Choe, R.Cottrell, J.Doyle, W.Feng, O.Martin, H.Newman, F.Paganini, S.Ravot and S.Singh, "Fast tcp: from theory to experiments", IEEE Network, 2005, pp 4-11
- [3]S.Low D.Wei, C.Jin and S.Hegde, "Fast tcp: motivation, architecture, algorithms, performance", IEEE/ACM Trans. on Networking, 2007, pp.
- [4]C.Hollot, V.Misra, D.Towsley and W.Gong, "On designing improved controllers for aqm routers supporting tcp flows", Proceedings of IEEE/INFOCOM, 2001
- [5]C.Hollot, V.Misra, D.Towsley and W.Gong, "A control theoretic analysis of red", Proceedings of IEEE/INFOCOM, 2001
- [6]S.Low, F.Paganini, J.Wang, S.Adlakha and J.Doyle, "Dynamics of tcp/aqm and a scalable control", Proceedings of IEEE INFOCOM, 2002
- [7]S.Low, F.Paganini, Z.Wang and J.Doyle,"A new tcp/aqm for stable operation in fast networks", Proceedings of IEEE INFOCOM, 2003
- [8]F.Paganini, J.Doyle and S.Low, "Scalable laws for stable network congestion control", Proceedings of Conference on Decision and Control, 2001
- [9]G.Vinnicombe, "On the stability of networks operating tcp-link congestion control", Proceedings of IFAC World Congress, 2002

- [10]I.Lestas and G.Vinnicombe, "Scalable robust stability for nonsymmetric heterogeneous networks", *Automatica*, 2006
- [11]S.Floyd and V.Jacobson, "Random early detection gateways for congestion avoidance", *IEEE/ACM Trans. on Networking*, 1993, pp 397-413
- [12]W.Feng, D.Kandlur, D.Saha and K.Shin, "A self-configuring red gateway", *Proceedings of IEEE/INFOCOM*, 1999
- [13]R.Gibbson and F.Kelly, "Distributed connection acceptance control for a connectionless network", *Proceedings of the 16th International Teletraffic Congress*, 1999
- [14]S.Low, S.Athuraliya, V.Li and Q.Yin, "Rem:active queue management", *IEEE Network*, 2001
- [15]S.Kunniyur and R.Srikant, "Analysis and design of an adaptive virtual queue", *Proceedings of ACM SIGCOMM*, 2001
- [16]C.Hollot, V.Misra, D.Towsley and W.Gong, "Analysis and design of controllers for aqm routers supporting tcp flows", *IEEE Trans. on Automatic Control*, 2002, pp 945-959
- [17]R.Watanabe, K.Uchida, M.Fujita and E.Shimemura, "L2 gain and H-infinity control of linear systems with scheduling parameter", *Proceedings of of 33rd IEEE Conference on Decision and Control*, 1994, pp 1412-1414
- [18]W.Rugh and J.Shamma, "*Research on gain scheduling*", *Automatica*, 2000, pp 1401-1425
- [19]T.Azuma, R.Watanabe and K.Uchida, "*Constrained state feedback h-infinity control of nonlinear systems*", *Proceedings of the 3rd Asian Control Conference*, 2000, pp 476-479
- [20]T.Azuma, H.Naito and M.Fujita, "*Stabilization of linear time-delay systems with self-scheduling parameters and the application to a stabilizing congestion control synthesis for tcp/aqm networks*," *Proceedings of IFAC Workshop on Time Delay Systems*, 2004
- [21]T.Azuma, H.Naito and M.Fujita, "*Experimental verification of stabilizing congestion controllers using the network testbed*", *Proceeding of the 2005 American Control Conference*, 2005, pp 1841-1846
- [22]V.Misra, W.Gong and R.Srikant, "*Robust rate control for abr sources*", *Proceedings of ACM/SIGCOMM*, 2000
- [23]C.Hollot and Y.Chait, "*Nonlinear stability analysis for a class of tcp/aqm networks*", *Proceedings of Conference on Decision and Control*, 2001
- [24]T.Azuma, R.Watanabe and K.Uchida, "*An approach to solving parameter dependent lmi conditions based on finite number of lmi conditions*", *Proceedings of American Control Conference*, 1997, pp 510-514
- [25]T.Azuma, R.Watanabe and K.Uchida, "*A new lmi approach to analysis of linear systems depending on scheduling parameter in polynomial forms*", *Automatisierungstechnik*, 2000, pp 119-204
- [26]T.Azuma and H.Hirano, "*A design of congestion controllers for computer networks using robust state predictive control*", *Proceedings of Computational Intelligence, Robotics and Autonomous Systems (crias2005)*, 2005, Paper No. IC2-2