



PERFORMANCE AND ANALYSIS OF AUTOMATIC LICENSE PLATE LOCALIZATION AND RECOGNITION FROM VIDEO SEQUENCES

¹M.Anto Bennet, ¹B.Thamilvalluvan ²Priyanka Paree Alphonse² D.R.Thendralarasi ^{*2}K.Sujithra

¹ Faculty of Electronics and Communication Department, vel tech, Chennai, India.

² UG Students of Electronics and Communication Department, vel tech , Chennai, India.

* Email: bennetmab@gmail.com

Submitted: May 27, 2017 Accepted: June 15, 2017 Published: Sep 1, 2017

Abstract- The works presents license plate recognition system using connected component analysis and template matching model for accurate identification. Automatic license plate recognition (ALPR) is the extraction of vehicle license plate information from an image. The system model uses already captured images for this recognition process. First the recognition system starts with character identification based on number plate extraction, Splitting characters and template matching. ALPR as a real life application has to quickly and successfully process license plates under different environmental conditions, such as indoors, outdoors, day or night time. It plays an important role in numerous real-life applications, such as automatic toll collection, traffic law enforcement, parking lot access control, and road traffic monitoring. The system uses different templates for identifying the characters from input image. After character recognition, an identified group of characters will be compared with database number plates for authentication. The proposed model has low complexity and less time consuming interms of number plate segmentation and character recognition. This can improve the system performance and make the system more efficient by taking relevant sample.

Index terms: Plate Recognition (LPR), Automatic license plate recognition (ALPR),Optical Character Recognition(OCR).

I. INTRODUCTION

AUTOMATIC license plate recognition (LPR) plays an important role in numerous applications such as unattended parking lots security control of restricted areas traffic law enforcement congestion pricing and automatic toll collection. Due to different working environments, LPR techniques vary from application to application. Pointable cameras create dynamic scenes when they move, pan or zoom. A dynamic scene image may contain multiple license plates or no license plate at all. Moreover, when they do appear in an image, license plates may have arbitrary sizes, orientations and positions. And, if complex backgrounds are involved, detecting license plates can become quite a challenge. Typically, an LPR process consists of two main stages (1) locating license plates and (2) identifying license numbers. In the first stage, license plate candidates are determined based on the features of license plates. Features commonly employed have been derived from the license plate format and the alphanumeric characters constituting license numbers. The features regarding License plate format include shape, symmetry height-to-width ratio color texture of grayness spatial frequency and variance of intensity values Character features include line blob the sign transition of gradient magnitudes, the aspect ratio of characters the distribution of intervals between characters and The alignment of characters. In reality, a small set of robust, reliable, and easy-to-detect object features would be adequate.

The license plate candidates determined in the locating stage are examined in the license number identification stage. There are two major tasks involved in the identification stage, Number separation and Number recognition. Number separation has in the past been accomplished by such techniques as projection morphology relaxation labeling, connected components and blob coloring. Since the projection method assumes the orientation of a license plate is known and the morphology method requires knowing the sizes of characters. A hybrid of connected components and blob coloring techniques is considered for character separation. Support Vector machine Markov processes and finite automata these methods can be broadly classified into iterative and Noniterative approaches. There is a tradeoff between these two Groups of approaches; iterative methods achieve better accuracy, but at the cost of increased time complexity. For this, we developed our own character recognition technique, which is based on the disciplines of both artificial neural networks and mechanics.

1.1 Existing System

In order to segment the characters in the binary license plate image the method named peak-to-valley is used. The method first segments the picture in digit images getting the two bounds of the each digit segment according to the statistical parameter $DIGIT_WIDTH = 18$ and $MIN_AREA = 250$. For that purpose, it uses a recursive function which uses the graph of the sums of the columns in the LP binary image. Otherwise, if the bandwidth is good, the two bounds of the signal with this bandwidth are taken as a digit segment, and the function is recursively called for the part of the image which is at the right side of the digit segment just found. This is done until the whole width of the picture has been passed over[1,2]. Once this segmentation has finished, the method keeps in the result only segment for which the area of the smallest rectangle containing them is more than MIN_AREA ; then, it keeps only the seven segments in the result with largest area, and in case less than seven segments were found, it attempts to recall the whole method, after making the separation between the already found segments clearer (by cleaning the bits which are there)[3,4,5]. License plates have always clear signature which corresponds to strong white level variations at somehow "regular" intervals. Due to noises, the variations are not always ideal and our algorithm permits to repair those variations. The method proved to be very accurate. In some rare cases, digit may be cut or two digit may appear in the same segment; this is especially the case when the image is blurred due to motion or when the contrast of the LP is very poor. Given the digit image obtained at the precedent step, this digit is compared to digits images in a dataset, and using the well-known Neural Network method, after interpolations, approximations and decisions algorithm, the OCR machine outputs the closest digit in the dataset to the digit image which was entered. As known, neural network is a function from vector to vector, and consists of an interpolation to a desired function[6,7,8]. Matlab provides very easy-to-use tools for Neural Networks which permits to concentrate on the digit images dataset only.

As known, in order for an OCR application based on the Neural Network technique to be operational, its dataset must be as large as possible and include a large variety of cases. It appeared that most of the cases in which our program fails are due to the neural network dataset which includes only 238 digits. In future works, it is crucial to enlarge the neural network dataset, because it is expected to improve dramatically the whole program accuracy[9,10].

II. PROPOSED SYSTEM

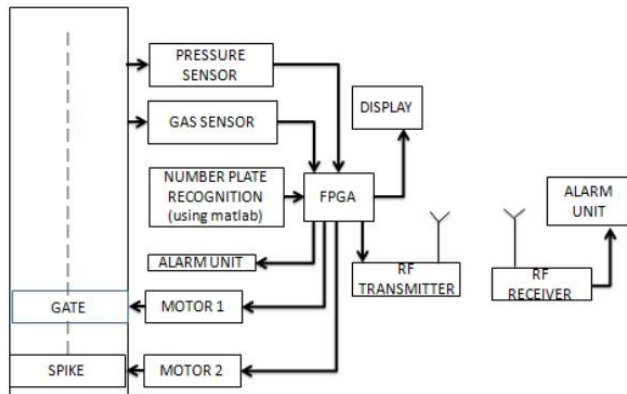

Fig 1 : Block diagram of proposed system

The goal of image segmentation is to cluster pixels into salient image regions, i.e., regions corresponding to individual surfaces, objects, or natural parts of objects. In computer vision segmentation refers to the process of partitioning a digital image to multiple segments. The goal of segmentation is to simplify and/or change the representation of an image into something that is more meaningful and easier to analyze. Image segmentation is typically used to locate objects and boundaries (lines, curves, etc.) in images. More precisely, image segmentation is the process of assigning a label to every pixel in an image such that pixels with the same label share certain visual characteristics. The result of image segmentation is a set of segments that collectively cover the entire image, or a set of contours extracted from the image. Each of the pixels in a region are similar with respect to some characteristic or computed property, such as color, intensity, or texture. Adjacent regions are significantly different with respect to the same characteristics shown in fig 1.

2.1 Optimal threshold value method

Lung parenchyma images segmentation was based primarily on that the CT density of lung parenchyma was lower, while the pleura surrounding bone, soft tissue, mediastinum and others' were higher. The automatic segmentation process in this article includes global threshold binarization, extract the boundary to remove the background of the trunk, threshold binarization after get rid of the background, lung parenchyma extraction, and lung area repair and so on. This article presents a new algorithm based on two binarization operations. It reduced the influence

effect of lung parenchyma to the lung parenchyma boundary, made the repairing of lung regions easier. It proposes a new repairing algorithm combining with mathematics morphology, which can make the repairing of lung parenchyma boundary more accurately. The detail of the algorithm is as follows.

2.2 Global threshold binarization

Lower CT values of lung tissue with the surrounding tissue higher CT value formed a relatively sharp contrast, so as to higher CT value of the surrounding tissue and lower CT value of background regions. Therefore, in this article, we use the optimal threshold value method for each site CT images to automatically generate optimal threshold value. The basic steps of the method are as follows:

- (1) Set the initial threshold $T = (\text{the maximum value of the image brightness} + \text{the minimum value of the image brightness})/2$;
- (2) Using T segment the image to get two sets of pixels B (all the pixel values are less than T) and N (all the pixel values are greater than T);
- (3) Calculate the average value of B and N separately, mean b and n . Fourth: Calculate the new threshold: $T = (b+n)/2$ Fifth: Repeat the second step to the fourth step until the iterative conditions are met (the iterative difference of T is less than the scheduled parameters). Set T_n is the threshold obtained by calculates, T_s is the final threshold we used. For the main purpose of our next step is preparing to extract the boundary of trunk, while the pixel value of outside region of trunk is lower, so in order to ensure it will be separated correctly, we lower the threshold appropriately:

$$T_s = T_n - T (\text{a fixed value set in advance})$$

III. MORPHOLOGICAL PROCESS

3.1 Dilation and Erosion

From these two Minkowski operations we define the fundamental mathematical morphology operations dilation and erosion. These two operations are illustrated in Figure 2(a) for the objects defined in Figure 2(b)..

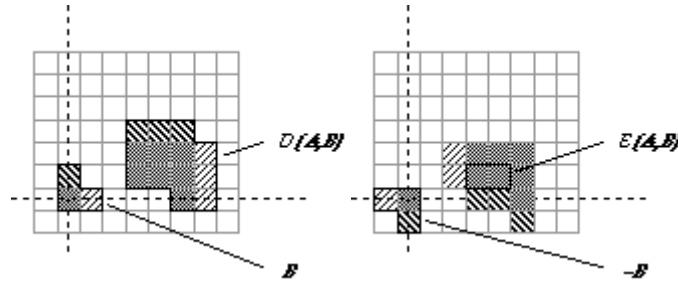

Fig.2(a) Dilation $D(A,B)$ (b) Erosion $E(A,B)$

A binary image containing two object sets A and B. The three pixels in B are "color-coded" as is their effect in the result. While either set A or B can be thought of as an "image", A is usually considered as the image and B is called a structuring element. The structuring element is to mathematical morphology what the convolution kernel is to linear filter theory. Dilation, in general, causes objects to dilate or grow in size; erosion causes objects to shrink. The amount and the way that they grow or shrink depend upon the choice of the structuring element. Dilating or eroding without specifying the structural element makes no more sense than trying to lowpass filter an image without specifying the filter. The two most common structuring elements (given a Cartesian grid) are the 4-connected and 8-connected sets, N_4 and N_8 . They are illustrated in fig 3.

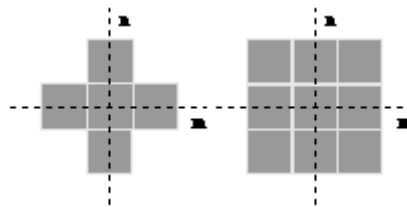
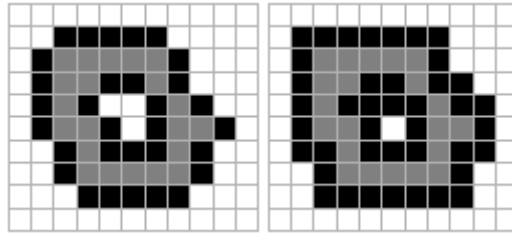

Fig 3The standard structuring elements N_4 and N_8 . (a) N_4 (b) N_8

Dilation- Take each binary object pixel (with value "1") and set all background pixels (with value "0") that are C-connected to that object pixel to the value "1".

Erosion - Take each binary object pixel (with value "1") that is C-connected to a background pixel and set the object pixel value to "0".

Comparison of these two procedures to eq. where $B = N_{C=4}$ or $N_{C=8}$. Fig 4 shows that they are equivalent to the formal definitions for dilation and erosion. The procedure is illustrated for dilation.



(a) $B = N_4$ (b) $B = N_8$

Fig 4: Illustration of dilation.

Original object pixels are in gray; pixels added through dilation are in black. The results of the application of these basic operations on a test image are illustrated below. In Figure 40 the various structuring elements used in the processing are defined. The value "-" indicates a "don't care". All three structuring elements are symmetric. The results of processing are shown in Fig 5 where the binary value "1" is shown in black and the value "0" in white.



a) Image A b) Dilation with 2B c) Erosion with 2B



d) Opening with 2B e) Closing with 2B f) Hit-and-Miss with B_1 and B_2

Fig5: Examples of morphology operations.

The opening operation can separate objects that are connected in a binary image. The closing operation can fill in small holes. Both operations generate a certain amount of smoothing on an object contour given a "smooth" structuring element. The opening smooths from the inside of the object contour and the closing smooths from the outside of the object contour.

3.2 Connected Component Analysis.

The output of the change detection module is the binary image that contains only two labels, i.e., '0' and '255', representing as 'background' and 'foreground' pixels respectively, with

Performance and analysis of automatic license plate localization and recognition from video sequences some noise. The goal of the connected component analysis is to detect the large sized connected foreground region or object. This is one of the important operations in motion detection. The pixels that are collectively connected can be clustered into changing or moving objects by analyzing their connectivity. In binary image analysis, the object is extracted using the connected component labelling operation, which consist of assigning a unique label to each maximally connected Foreground region of pixels. One of the important labelling approaches is “classical sequential labelling algorithm” . It is based on two raster scan of binary image. The first scan performs the temporary labelling to each foreground region pixels by checking their connectivity of the scanned image. When a foreground pixel with two or more than two foreground neighbouring pixels carrying the same label is found, the labels associated with those pixels are registered as being equivalent. That means these regions are from the same object. The handling of equivalent labels and merging thereafter is the most complex task.

3.3 Local Region Descriptors

The Labelled objects within a sign are applied to measure its characteristics which are useful to recognize a sign with stored templates. The following features are extracted, Area, Orientation, Height, width, Eccentricity, Major axis Length, Minor axis length, perimeter and Equivalent diameter

3.4 K-NEAREST NEIGHBOUR:

In pattern recogniton, the k-nearest neighbor algorithm (k-NN) is a method for classifying objects based on closest training examples in the feature space. k-NN is a type of instance-based learning, or lazy learning where the function is only approximated locally and all computation is deferred until classification. The k-nearest neighbor algorithm is amongst the simplest of all machine learning algorithms: an object is classified by a majority vote of its neighbors, with the object being assigned to the class most common amongst its k nearest neighbors (k is a positive integer, typically small). If $k = 1$, then the object is simply assigned to the class of its nearest neighbor. The same method can be used for regression, by simply assigning the property value for the object to be the average of the values of itsk nearest neighbors. It can be useful to weight the contributions of the neighbors, so that the nearer neighbors contribute more to the average than the more distant ones. (A common weighting scheme is to give each neighbor a weight of $1/d$,

where d is the distance to the neighbor. This scheme is a generalization of linear interpolation.) The neighbors are taken from a set of objects for which the correct classification (or, in the case of regression, the value of the property) is known. This can be thought of as the training set for the algorithm, though no explicit training step is required. The k -nearest neighbor algorithm is sensitive to the local structure of the data. Nearest neighbor rules in effect implicitly compute the decision boundary. It is also possible to compute the decision boundary explicitly, and to do so efficiently, so that the computational complexity is a function of the boundary complexity

3.5 PARAMETER SELECTION:

The best choice of k depends upon the data; generally, larger values of k reduce the effect of noise on the classification, but make boundaries between classes less distinct. A good k can be selected by various heuristic techniques, for example, cross-validation. The special case where the class is predicted to be the class of the closest training sample (i.e. when $k=1$) is called the nearest neighbor algorithm. The accuracy of the k -NN algorithm can be severely degraded by the presence of noisy or irrelevant features, or if the feature scales are not consistent with their importance. Much research effort has been put into selecting or scaling features to improve classification. Another popular approach is to scale features by the mutual information of the training data with the training classes. In binary (two class) classification problems, it is helpful to choose k to be an odd number as this avoids tied votes. One popular way of choosing the empirically optimal k in this setting is via bootstrap method.

3.6 Algorithm Description:

If we want to tune the value of ' k ' and/or perform feature selection, n -fold cross-validation can be used on the training dataset. The testing phase for a new instance ' t ', given a known set ' T ' is as follows:

1. Compute the distance between ' t ' and each instance in ' T '
2. Sort the distances in increasing numerical order and pick the first ' k ' elements
3. Compute and return the most frequent class in the ' k ' nearest neighbours, optionally weighting each instance's class by the inverse of its distance to ' t '

3.7 SIMULATED RESULTS CHARACTER RECOGNITION

Performance and analysis of automatic license plate localization and recognition from video sequences

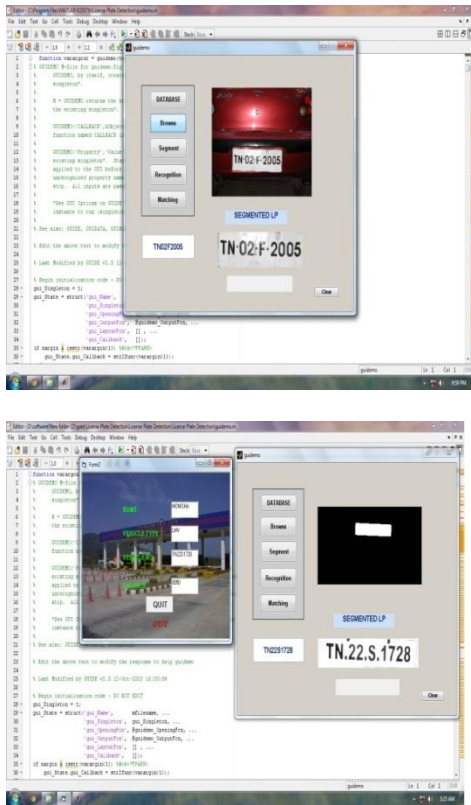

Fig.6 Number Plate Recognition and Segmentation

Fig 7Toll GateDeduction

3.8 DEDUCTION

MATLAB software is used to recognise the number plate shown in fig 6.. Character Segmentation is performed. Morphological operations are carried out to extract the number. Authentication is also done.The image is obtained from the built in database and it is verified.Visual Basic is used to create a user database. As the Character is recognised and authenticated, the databse is automatically accesed. The amount predefined in the account varies accordance to the variation in the weight demonstrated using the pressure sensor shown in fig 7..The Kit consists of RF transimission and receiver sections supported with a gas sensor. Sensor circuits are connected to the FPGA and the programs are dumped into it. DC motors are also connected with the alarm circuit. System interface is performed for NP recognition and Toll calculation shown in fig 8.



Fig.8 Experimental Setup

IV. CONCLUSION

ANPR can be further exploited for vehicle owner identification, vehicle model identification traffic control, vehicle speed control and vehicle location tracking. It can be further extended as multilingual ANPR to identify the language of characters automatically based on the training data. It can provide various benefits like traffic safety enforcement, security- in case of suspicious activity by vehicle, easy to use, immediate information availability- as compare to searching vehicle owner registration details manually and cost effective for any country. For low resolution images some improvement algorithms like super resolution. Most of the ANPR focus on processing one vehicle number plate but in real-time there can be more than one vehicle number plates while the images are being captured. Multiple vehicle number plate images are considered for ANPR while in most of other systems offline images of vehicle, taken from online database are given as input to ANPR so the exact results may deviate from the results. To segment multiple vehicle number plates a coarse-to-fine strategy could be helpful. It is quite clear that ANPR is difficult system because of different number of phases and presently it is not possible to achieve 100% overall accuracy as each phase is dependent on previous phase. Certain factors like different illumination conditions, vehicle shadow and non-uniform size of license plate characters, different font and background color affect the performance of ANPR. Some systems work in these restricted conditions only and might not produce good amount of accuracy in adverse conditions.

REFERENCES

Performance and analysis of automatic license plate localization and recognition from video sequences

[1] Aizat Azmi, Ahmad Amsyar Azman, Sallehuddin Ibrahim, and Mohd Amri Md Yunus, "Techniques In Advancing The Capabilities Of Various Nitrate Detection Methods: A Review", International Journal on Smart Sensing and Intelligent Systems., VOL. 10, NO. 2, June 2017, pp. 223-261.

[2] Tsugunosuke Sakai, Haruya Tamaki, Yosuke Ota, Ryohei Egusa, Shigenori Inagaki, Fusako Kusunoki, Masanori Sugimoto, Hiroshi Mizoguchi, "Eda-Based Estimation Of Visual Attention By Observation Of Eye Blink Frequency", International Journal on Smart Sensing and Intelligent Systems., VOL. 10, NO. 2, June 2017, pp. 296-307.

[3] Ismail Ben Abdallah, Yassine Bouteraa, and Chokri Rekik , "Design And Development Of 3d Printed Myoelectric Robotic Exoskeleton For Hand Rehabilitation", International Journal on Smart Sensing and Intelligent Systems., VOL. 10, NO. 2, June 2017, pp. 341-366.

[4] S. H. Teay, C. Batunlu and A. Albarbar, "Smart Sensing System For Enhanceing The Reliability Of Power Electronic Devices Used In Wind Turbines", International Journal on Smart Sensing and Intelligent Systems., VOL. 10, NO. 2, June 2017, pp. 407- 424

[5] SCihan Gercek, Djilali Kourtiche, Mustapha Nadi, Isabelle Magne, Pierre Schmitt, Martine Souques and Patrice Roth, "An In Vitro Cost-Effective Test Bench For Active Cardiac Implants, Reproducing Human Exposure To Electric Fields 50/60 Hz", International Journal on Smart Sensing and Intelligent Systems., VOL. 10, NO. 1, March 2017, pp. 1- 17

[6] P. Visconti, P. Primiceri, R. de Fazio and A. Lay Ekuakille, "A Solar-Powered White Led-Based Uv-Vis Spectrophotometric System Managed By Pc For Air Pollution Detection In Faraway And Unfriendly Locations", International Journal on Smart Sensing and Intelligent Systems., VOL. 10, NO. 1, March 2017, pp. 18- 49

[7] Samarendra Nath Sur, Rabindranath Bera and Bansibadan Maji, "Feedback Equalizer For Vehicular Channel", International Journal on Smart Sensing and Intelligent Systems., VOL. 10, NO. 1, March 2017, pp. 50- 68

[8] Yen-Hong A. Chen, Kai-Jan Lin and Yu-Chu M. Li, "Assessment To Effectiveness Of The New Early Streamer Emission Lightning Protection System", International Journal on Smart Sensing and Intelligent Systems., VOL. 10, NO. 1, March 2017, pp. 108- 123

[9] Iman Heidarpour Shahrezaei, Morteza Kazerooni and Mohsen Fallah, "A Total Quality Assessment Solution For Synthetic Aperture Radar Nlfm Waveform Generation And Evaluation

In A Complex Random Media”, International Journal on Smart Sensing and Intelligent Systems., VOL. 10, NO. 1, March 2017, pp. 174- 198

[10] P. Visconti ,R.Ferri, M.Pucciarelli and E.Venere, “Development And Characterization Of A Solar-Based Energy Harvesting And Power Management System For A Wsn Node Applied To Optimized Goods Transport And Storage”, International Journal on Smart Sensing and Intelligent Systems., VOL. 9, NO. 4, December 2016 , pp. 1637- 1667

[11] YoumeiSong,Jianbo Li, Chenglong Li, Fushu Wang, “Social Popularity Based Routing In Delay Tolerant Networks”, International Journal on Smart Sensing and Intelligent Systems., VOL. 9, NO. 4, December 2016 , pp. 1687- 1709

[12] Seifeddine Ben Warrad and OlfaBoubaker, “Full Order Unknown Inputs Observer For Multiple Time-Delay Systems”, International Journal on Smart Sensing and Intelligent Systems., VOL. 9, NO. 4, December 2016 , pp. 1750- 1775

[13] Rajesh, M., and J. M. Gnanasekar. "Path observation-based physical routing protocol for wireless ad hoc networks." International Journal of Wireless and Mobile Computing 11.3 (2016): 244-257.

[14]. Rajesh, M., and J. M. Gnanasekar. "Congestion control in heterogeneous wireless ad hoc network using FRCC." Australian Journal of Basic and Applied Sciences 9.7 (2015): 698-702.

[15]. Rajesh, M., and J. M. Gnanasekar. "GCCover Heterogeneous Wireless Ad hoc Networks." Journal of Chemical and Pharmaceutical Sciences (2015): 195-200.

[16]. Rajesh, M., and J. M. Gnanasekar. "CONGESTION CONTROL USING AODV PROTOCOL SCHEME FOR WIRELESS AD-HOC NETWORK." Advances in Computer Science and Engineering 16.1/2 (2016): 19.

[17]. Rajesh, M., and J. M. Gnanasekar. "An optimized congestion control and error management system for OCCEM." International Journal of Advanced Research in IT and Engineering 4.4 (2015): 1-10.

[18]. Rajesh, M., and J. M. Gnanasekar. "Constructing Well-Organized Wireless Sensor Networks with Low-Level Identification." World Engineering & Applied Sciences Journal 7.1 (2016).

[19] L. Jamal, M. Shamsujjoha, and H. M. Hasan Babu, “Design of optimal reversible carry look-ahead adder with optimal garbage and quantum cost,” International Journal of Engineering and Technology, vol. 2, pp. 44–50, 2012.

M.Anto Bennet, B.Thamilvalluvan, Priyanka Paree A phones, D.R.Thendralarasi and K.Sujithra

Performance and analysis of automatic license plate localization and recognition from video sequences

[20] S. N. Mahammad and K. Veezhinathan, "Constructing online testable circuits using reversible logic," IEEE Transactions on Instrumentation and Measurement, vol. 59, pp. 101–109, 2010.

[21] W. N. N. Hung, X. Song, G. Yang, J. Yang, and M. A. Perkowski, "Optimal synthesis of multiple output boolean functions using a set of quantum gates by symbolic reachability analysis," IEEE Trans. on CAD of Integrated Circuits and Systems, vol. 25, no. 9, pp. 1652–1663, 2006.

[22] F. Sharmin, M. M. A. Polash, M. Shamsujjoha, L. Jamal, and H. M. Hasan Babu, "Design of a compact reversible random access memory," in 4th IEEE International Conference on Computer Science and Information Technology, vol. 10, june 2011, pp. 103–107.

[23] Dr. AntoBennet, M, Sankar Babu G, Suresh R, Mohammed Sulaiman S, Sheriff M, Janakiraman G ,Natarajan S, "Design & Testing of Team Faults Using T_H Algorithm", Middle-East Journal of Scientific Research 23(08): 1921-1929, August 2015 .

[24] Dr. AntoBennet, M "Power Optimization Techniques for sequential elements using pulse triggered flipflops", International Journal of Computer & Modern Technology , Issue 01 ,Volume01 ,pp 29-40, June 2015.