



## ANDROID BASED HOME AUTOMATION AND ENERGY CONSERVATION

<sup>1\*</sup>M.Anto Bennet, <sup>2</sup>B.Thamilvalluvan, <sup>2</sup>C.A.Hema Priya, <sup>2</sup> B.Bhavani, <sup>2</sup>M.Shalini

<sup>1</sup> Faculty of Electronics and Communication Department, vel tech, Chennai, India.

<sup>2</sup> UG Students of Electronics and Communication Department, vel tech , Chennai, India.

Email: [bennetmab@gmail.com](mailto:bennetmab@gmail.com)

---

**Submitted: May 27, 2017**

**Accepted: June 15, 2017**

**Published: Sep 1, 2017**

---

*Abstract- Wireless Sensor Network (WSN) consists of three main components: nodes, gateways, and software. The spatially distributed measurement nodes interface with sensors to monitor assets or their environment. In a WSN network the devices are connected to WSN nodes wherein the entire nodes uses Zigbee network to transfer the status of connected applications to a controller which controls the whole applications but the main drawback of Wireless sensor networks is its high interference, low coverage area and ability to control only low power devices. In order to overcome these drawbacks Android equipped devices are used to control the applications over GPRS network. Android equipped devices allow the user to control various applications over wireless networks. Being an open sourced platform it allows the user to design a custom module which controls the home applications by connecting the android equipped device and its corresponding home applications to an MCU wherein it uses relay circuits to connect the entire applications using GPRS network to connect the application controller and the android device. These devices can be used to control industrial applications, home applications like light, fan etc., and thereby conserving electricity.*

**Index terms:** Wireless Sensor Network (WSN), Network Centric Capability(NCC),Data Terminal Equipment ( DTE ),Software Defined Radio (SDR)

## I. INTRODUCTION

The objective of this work is the autonomous functioning, monitoring as well as control of various household devices by harnessing the power of embedded systems and wireless communication technology, more specifically, the open source android mobile platform. This work addresses various issues related to design and deployment of a Web-enabled distributed control application platform for industrial automation. The built-in Web functions enable programming and execution of remote control applications through Stand alone android applications. New control applications can be created and existing control applications can be reconfigured and tuned on the go. The aim of the proposed work is to present a security integrated system, based on the WAP framework for remote monitoring and control of home appliances. It's the recent trend to control the device through web. Suppose if we are in need to control any device, the option will be provided in the control interface of the mobile applications and we are able to control the device at any moment. Relay driver circuit does the controlling of the device. A WAP gateway located nearer to the home appliances is responsible for executing the supplied control algorithm. While serving concurrent requests from other clients, user can gain access to the system through WAP enabled mobile phone. The kernel of the integrated system relies on data flow programming platform. General packet radio service (GPRS) is a packet oriented mobile data service on the 2G and 3G cellular communication system's global system for mobile communications (GSM). GPRS became the first stepping-stone on the path between the second-generation GSM cellular technology and the 3G W-CDMA / UMTS system. With GPRS technology offering data services with data rates up to a maximum of 172 kbps, facilities such as web browsing and other services requiring data transfer became possible. Although some data could be transferred using GSM, the rate was too slow for real data applications.

## II. LITERATURE SURVEY

Wireless Mechatronic systems and services experience a fast growth in variety of application fields such as manufacturing, transportation and healthcare in future it will be really useful for assisting health care for particularly for elderly and disabled. Another great example is radio frequency identification system known as RFID it mainly finds its application over the fields like manufacturing, security, logistics, airline baggage management[1]. Surveillance and monitoring

of battlefield operations is done by incorporating Unattended Ground Sensors(UGS) through Network Centric Capability(NCC) techniques. UGSs have the ability to perform surveillance operations autonomously. NCC provides the advantage for UGS networks to self-manage their limited resources effectively[2].Detection of flame over the past has been done through smoke detectors which detects the flame only during the presence of considerable amount of smoke and is subject to give false alarms. In order to overcome these difficulties UV detectors are used to detect the Ultraviolet radiation from the flame and transfer the rate of UV detected to trigger alarm through a Zig-Bee based wireless sensor network. The detected UV rates are transferred to its Zig-Bee transceiver which forwards the data to the control unit [3]. Real time monitoring of vital physiological data such as ECG EEG etc., is done by remote surveillance through integrated multitier wireless networks. A small electronic device collect the vital physiological data attached to the patients body and transfers the data to body area network using 802.15.4 low data rate WPAN technology. The data from the body area network is transferred to the hospital network using 802.11 WLAN wireless technology. Since it uses two different network topologies with subsequent hops it is called as Multitier wireless network [4].Sensor networks play a vital role in extension of smart grids that focus on energy management applications they play important role in both energy conservation and reduction of carbon emission . The use of WSHAN (wireless sensor home area network) includes performance parameters like packet delivery ratio, delay, jitter and bandwidth[5].At present, many countries have put forward their own smart grid plans and intelligent client in one study here AMR (automatic meter reading ) play an important role. Hence it becomes important to study the new AMR .AMR has many advantages when compared to zigbee network like high bandwidth ,non line transmission capacity , coverage range, cost effective, easy expansion, higher robustness and security[6].Smart meters are used for energy consumption which records data based on user's power consumption statistics. Minimum functionality smart meters (MF), Smart meters with In-home display(IHD) and Smart meters with applications demand control unit (DCU) are used[7].The design of smart home device descriptions and standard practices for demand response and load management "Smart Energy" applications needed in a smart energy based residential or light commercial environment is explained. The control application domains included in this initial version are sensing device control, pricing and demand response and load control applications. This paper introduces smart home interfaces and device definitions to allow interoperability among ZigBee devices produced

Android based home automation and energy conservation

by various manufacturers of electrical equipment, meters, and smart energy enabling products. We introduced the proposed home energy control systems design that provides intelligent services for users and we demonstrate its implementation using a real testbed [8]. This work shows the use Of Smart LT Apparent Energy Meters for Effective Reduction in ATC Losses. The technical component is reduced through the implementation for a fair apparent energy based tariff. This is an elegant single parameter (unit kVAh) based tariff that incorporates an embedded power factor based discount mechanism to offer a Win-Win solution, where consumers can avail discounts in their electricity bills while the utilities minimize their line losses through reduction in harmonics and inductive loads[7]. Electricity smart meters together with gas, heat, and water meters can be interconnected in a large network offering a potential value to implement energy savings and other energy-related services, as long as an efficient interface with the final user is implemented. Unfortunately, so far, the interface of such devices is mostly designed and addressed at the utilities supervising the system, giving them relevant advantages, while the communication with the household is often underestimated. This paper addresses this topic by proposing the definition of a local interface for smart meters, by looking at the actual European Union and international regulations, at the technological solutions available on the market, and at those implemented in different countries, and, finally, by proposing specific architectures for a proper consumer-oriented implementation of a smart meter network[9].

### III. PROPOSED METHOD

Android equipped devices are used to control the applications over GPRS network. Android equipped devices allow the user to control various applications over wireless networks. Being an open sourced platform it allows the user to design a custom module which controls the home applications by connecting the android equipped device and its corresponding home applications to an MCU wherein it uses relay circuits to connect the entire applications using GPRS network to connect the application controller and the android device. These devices can be used to control industrial applications, home applications like light, fan etc., and thereby conserving electricity.

The android module connects to the server using a static IP address. The static IP address must match the IP address used in the server to establish successful connection between the android module the server. Dynamic IP can also be used to connect when multiple android

modules are used to connect to the server. In order to avoid IP conflict between multiple android modules, the server is set up with a pool of dynamic IP addresses in which multiple android modules can connect to the server using the defined range of IP addresses by the server. Once the connection between the android module and the server is established the microcontroller board can communicate with the server using the hyper terminal. The COM ports are used to interface the microcontroller board to the computer (server). Once the connection between the microcontroller board and the server is established the android module can communicate directly with the microcontroller board using the HyperTerminal. Connection between android module and server is done by using GPRS network and connection between the microcontroller board and server is done by a USB to serial converter cable. The microcontroller board consists of the applications to be monitored and controlled

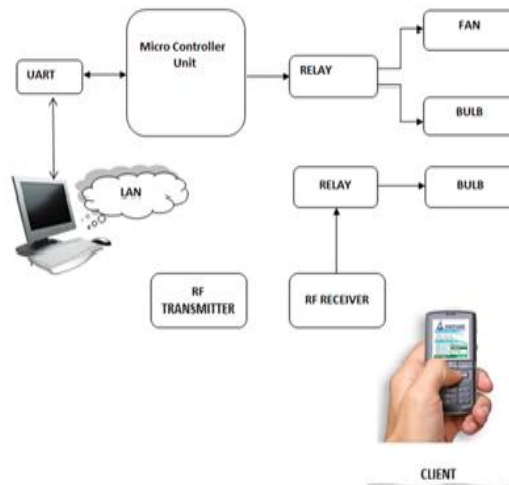

Fig.1 Block diagram of the proposed method

Once the connection between the home appliances and android module is established the devices are ready to be monitored and controlled. The soft keys present in the android application controls the home appliances. Figure 1 shows a graphical view of how the devices are connected. The client which is a android mobile send information to the server via GPRS network. The main principle behind the proposed method is the GPRS network to establish connection between the controlling module and the appliances. Once the information is been received by the server, the server communicates with the home appliance using the microcontroller board. According to the information by the microcontroller the status of the connected devices are changed received by the microcontroller the status of the connected devices are changed. The proposed method

Android based home automation and energy conservation

is composed of major blocks for the operation of the system. These individual block descriptions are as follows:

**3.1 POWER SUPPLY UNIT**

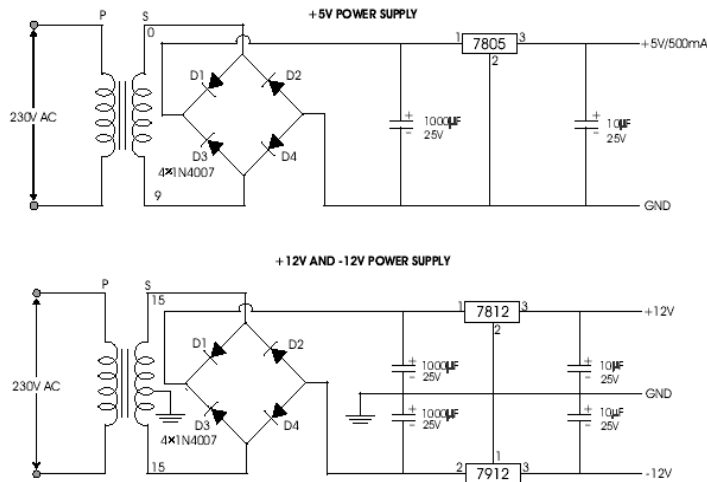

Fig. 2 Circuit Diagram of Power Supply

The AC voltage, typically 220V rms, is connected to a transformer in the figure 2, which steps that ac voltage down to the level of the desired DC output. A diode rectifier then provides a full-wave rectified voltage that is initially filtered by a simple capacitor filter to produce a dc voltage. This resulting dc voltage usually has some ripple or ac voltage variation. A regulator circuit removes the ripples and also remains the same dc value even if the input dc voltage varies, or the load connected to the output dc voltage changes.

**3.2 MICROCONTROLLER-PIC 16F877A:**

Microchip, the second largest 8-bit microcontroller supplier in the world, (Motorola is ranked No: 1) is the manufacturer of the PIC microcontroller and a number of other embedded control solutions. Check out the following links for an overview of the history of Microchip and PIC microcontrollers.

**3.3 RS232:**

When we look at the connector pin out of the RS232 port, we see two pins which are certainly used for flow control. These two pins are **RTS**, request to send and **CTS**, clear to send. With **DTE/DCE** communication (i.e. a computer communicating with a modem device) **RTS** is an output on the **DTE** and input on the **DCE**. **CTS** are the answering signal coming from the

**DCE.** Before sending a character, the **DTE** asks permission by setting its **RTS** output. No information will be sent until the **DCE** grants permission by using the **CTS** line.

### 3.4 AN RS232 TO TTL LEVEL CONVERTER:

The RS232/DB9 is designed to convert TTL level signals into RS232 level signals is shown in the figure 3.. This cable allows you to connect a TTL level device, such as the serial port on a Micro-controller, to the serial port of a personal computer. The conversion circuit is housed inside the DB9 connector shell. Power is supplied from the micro-controller board.

The board is based on the Maxim MAX3221CAE interface chip. This chip draws a mere 1mA of current when there are no RS-232 signals connected to the part. With the exception of the DB9 connector and the wire, all parts on this board are surface mounted, and require care during assembly. The mounting of surface mount parts is not difficult, but does require a steady hand. A magnifying glass or other visual aid may be helpful. You also need some electronic paste flux.

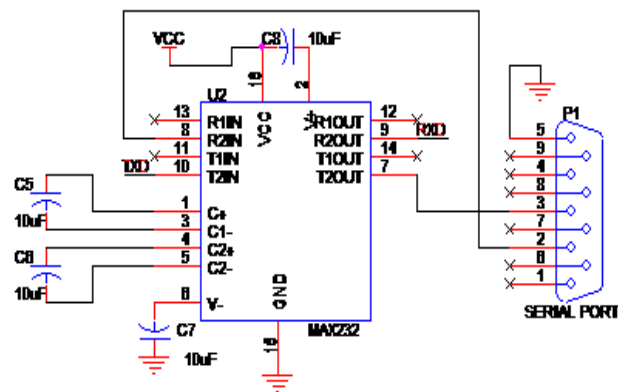

Fig.3 Circuit diagram of RS232 to TTL converter

### 3.5 DRIVER UNIT [RELAY]:

A relay is an electrically operated switch. Many relays use an electromagnet to operate a switching mechanism mechanically, but other operating principles are also used. Relays are used where it is necessary to control a circuit by a low-power signal (with complete electrical isolation between control and controlled circuits), or where several circuits must be controlled by one signal. The first relays were used in long distance telegraph circuits, repeating the signal coming in from one circuit and re-transmitting it to another. Relays were used extensively in telephone exchanges and early computers to perform logical operations. A type of relay that can handle the high power required to directly drive an electric motor is called a contractor. Solid-state relays control power circuits with no moving parts, instead using a semiconductor device to perform

switching. Relays with calibrated operating characteristics and sometimes multiple operating coils are used to protect electrical circuits from overload or faults; in modern electric power systems these functions are performed by digital instruments still called "protective relays". shown in fig 4.

### 3.6 POLE AND THROW:

Since relays are switches, the terminology applied to switches is also applied to relays. A relay will switch one or more *poles*, each of whose contacts can be *thrown* by energizing the coil in one of three ways:

- Normally-open (**NO**) contacts connect the circuit when the relay is activated; the circuit is disconnected when the relay is inactive. It is also called a **Form A** contact or "make" contact.
- Normally-closed (**NC**) contacts disconnect the circuit when the relay is activated; the circuit is connected when the relay is inactive. It is also called a **Form B** contact or "break" contact.
- Change-over (**CO**), or double-throw (**DT**), contacts control two circuits: one normally-open contact and one normally-closed contact with a common terminal. It is also called a **Form C** contact or "transfer" contact ("break before make"). If this type of contact utilizes a "make before break" functionality, then it is called a **Form D** contact.

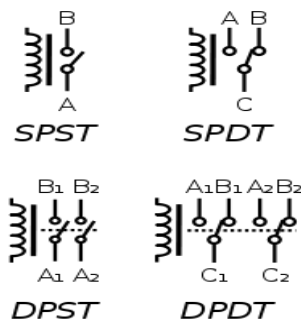

Fig.4 Circuit diagram of relays

### 3.7 UART UNIT:



A universal asynchronous receiver/transmitter, abbreviated UART is a piece of computer hardware translates data between parallel and serial forms. A UART (Universal Asynchronous Receiver/Transmitter) is the microchip with programming that controls a computer's interface to its attached serial devices. Specifically, it provides the computer with the RS-232C Data Terminal Equipment ( DTE ) interface so that it can "talk" to and exchange data with modems and other serial devices.

### **3.8 LCD DISPLAY:**

Short for liquid crystal display, a type of display used in digital watches and many portable computers. LCD displays utilize two sheets of polarizing material with a liquid crystal solution between them. An electric current passed through the liquid causes the crystals to align so that light cannot pass through them. Each crystal, therefore, is like a shutter, either allowing light to pass through or blocking the light. Monochrome LCD images usually appear as blue or dark gray images on top of a grayish-white background. Color LCD displays use two basic techniques for producing color: Passive matrix is the less expensive of the two technologies. The other technology, called thin film transistor (TFT) or active-matrix, produces color images that are as sharp as traditional CRT displays, but the technology is expensive. Recent passive-matrix displays using new CSTN and DSTN technologies produce sharp colors revealing active-matrix displays. Most LCD screens used in notebook computers are backlit, or transmissive, to make them easier to read.

### **3.9 RF TRANSCEIVER:**

The RF Transceiver uses RF modules for high speed data transmission. The micro-electronic circuits in the digital-RF architecture work at speeds up to 100 GHz. The objective in the design was to bring digital domain closer to the antenna, both at the receive and transmit ends using software defined radio (SDR). The software-programmable digital processors used in the circuits permit conversion between digital baseband signals and analog RF. The RF800 is a single chip telemetry device, which may be an encoder or a decoder. When combined with a Radio transmitter / receiver it may be used to provide a remote control system with upto 16 I/O lines. The RF800 performs all the necessary data manipulation and encryption for a optimum range reliable radio link whilst providing a simple user interface. The device has been designed to

Android based home automation and energy conservation

obtain the maximum range from the Radio path using automatic data packet generation with ‘Manchester’ encoding and CRC based error checking. The RF800 is compatible with the RF Solutions 200 series range of remote control products. An ‘integrated’ remote control can be generated using any of the 200 hand held transmitters. The RF800 is can be set to either encoder mode or decoder mode of operation. In all cases transmitters must be learnt to the RF800 decoder before any outputs will operate, thus enabling a secure telemetry system to be built with the possibility of several systems operating within a local environmentt shown in fig 5.



Fig. 5 RF Transceiver

#### IV. EXPERIMENTAL RESULTS

Automation is the process of enabling the functioning of different types of machines without the need for human interference or monitoring. Automation is usually achieved remotely with the help of wireless communication modules. This work makes use of GPRS technology, on a mobile android platform. The interface on the mobile device is developed using the software Eclipse Luna SR2 (4.4.2). Eclipse is an integrated development environment (IDE). It contains a base workspace and an extensible plug-in system for customizing the environment. Written mostly in Java, Eclipse can be used to develop applications.

##### 4.1 ANDROID CONTROL MODULE:

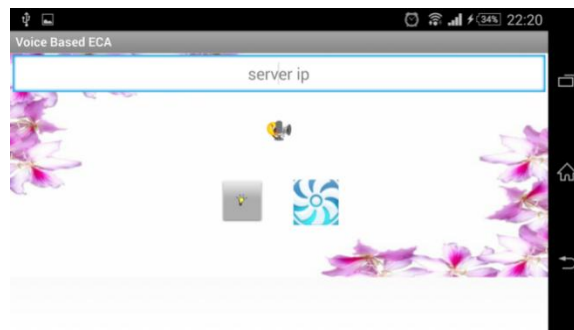

Fig.6 Application Output 1

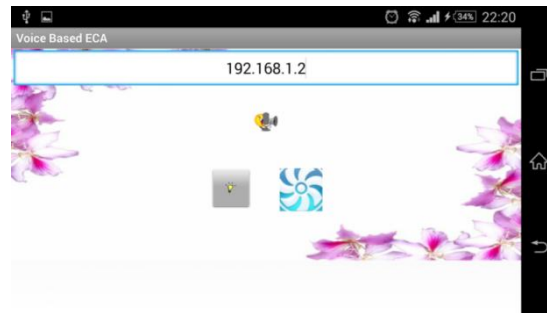

Fig.7 Application output 2

The output of the android application without any input is shown in figure 6. The application consists of three soft keys and one text field. The soft keys are light, fan and voice input. The text field is used to enter the IP address of the server. The text field after entering the IP address is shown in figure 7. when the IP address is entered the application automatically tries to connect to the server that has the same IP address.

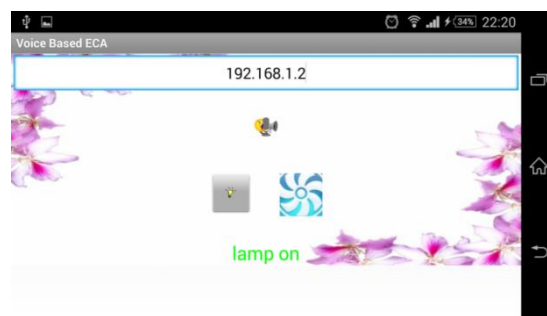

Fig.8. Application output 3

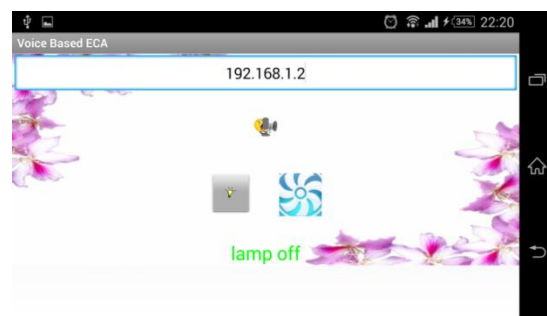

Fig.9 Application output 4

When the lamp soft key is pressed the application returns the status of the lamp as 'lamp on' at the bottom. Figure 8 shows the output when the lamp soft key is pressed. When the lamp soft key is pressed again the output is returned as 'lamp off'. Figure 9 shows the output when the lamp soft key is pressed again.

Android based home automation and energy conservation

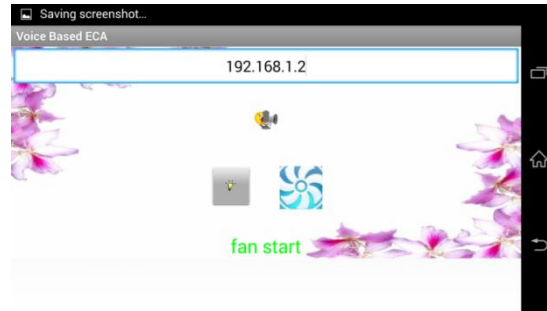

Fig.10 Application output 5



Fig.11 Application output 6

When the fan soft key is pressed the status of the fan is shown at the bottom of the screen. Figure 10 shows the output of the fan as 'fan start'. When the fan soft key is pressed again the status of the fan is displayed at the bottom of the screen. Figure 11 shows the output as 'fan stop'.

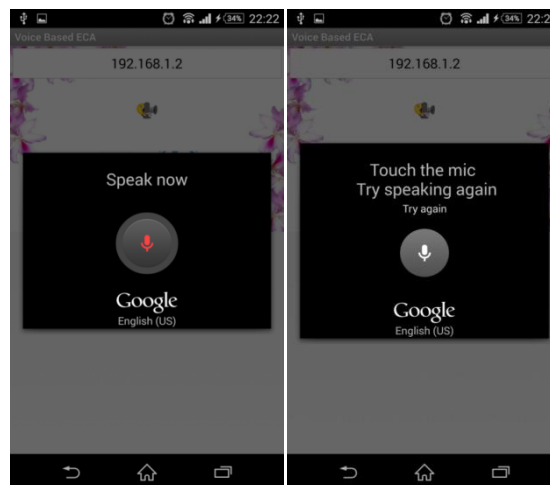

Fig 12 Application output 7

When the voice input soft key is pressed the output of the screen is displayed as shown in figure 12. It allows the user to give input in the form of voice instead of text. The left picture show the recording of voice being spoken and the right picture requests the user to speak again in case of

mismatched voices are unheard voices. The commands are transferred to the PIC 16f877a, which makes use of an embedded C instruction set, and subsequently controls the switching status of the household devices. Relays are used to control the flow of control signals from the microcontroller kit. DPST relays are used for this purpose.

#### 4.2 RF CONTROL MODULE:

Furthermore a wireless module is used for remote controlling of a household device using RF transceivers. The signals from the PC are parallel in nature which is converted into a microcontroller readable serial format by using a parallel to serial convertor. RS232 cables are used as a transmission link between the convertor and PIC microcontroller kit.

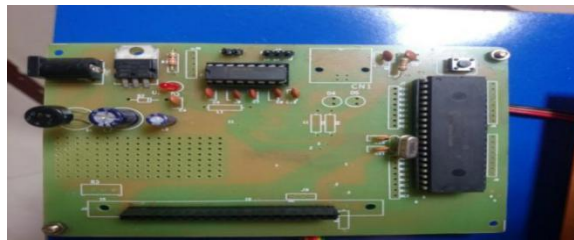

Figure 13 shows the overview of PIC microcontroller along with the interface board for LCD display.

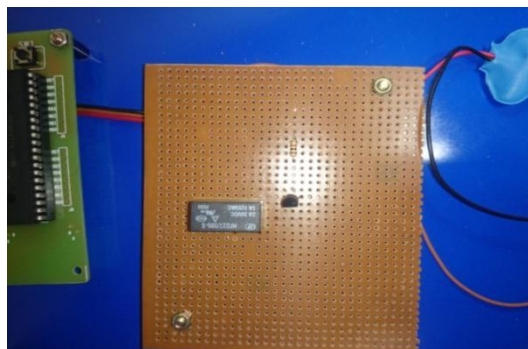

Fig.14 Relay Circuit



Fig15 PLC Controller

Figure 14 shows the active relay circuit being used in the work. Fig.16 PIC Controller and Relay Circuit. Figure 15 shows the PIC controller and relay circuit being connected together.



Fig.16 PIC Controller and Relay Circuit with connected Devices.

The end devices such as light and fan are connected to the relay circuit is shown in the figure 16.

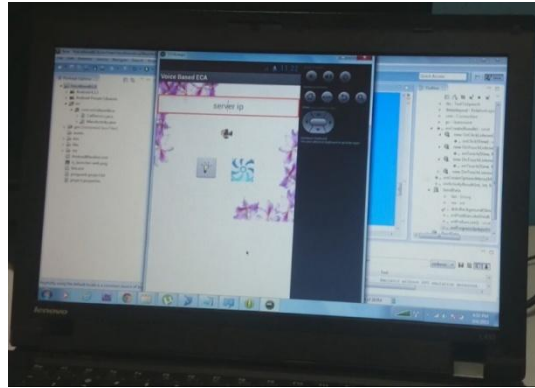

Fig.17 working of first connected device



Fig.18 working of second connected device

The working of one of the lights connected to the circuit is shown in figure 17. The working of second light connected to the circuit is shown in figure 18.



#### **4.3 HYPERTERMINAL CONTROL MODULE: Fig.19 Server**

The active hyperterminal server is shown in figure 19 which has the control modules just like the android application.

#### **V. CONCLUSION**

Smart grid networks are currently used for effective monitoring of the electrical networks. This is achieved by means of two way communication of electrical pulses as well as control and feedback information. This work improves on the existing model by adding efficient control modules which are capable of remotely triggering any device connected on a common network either ON or OFF, using GPRS technology on an Android Mobile Phone. The existent Zigbee network, while efficient for the control of Low power application becomes impractical at greater distances. Therefore in conclusion, this work enables simplification of the controlling of household devices by effectively harnessing the power of Embedded systems and Mobile Communication technology.

#### **REFERENCES**

- [1] Aizat Azmi, Ahmad Amsyar Azman, Sallehuddin Ibrahim, and Mohd Amri Md Yunus, "Techniques In Advancing The Capabilities Of Various Nitrate Detection Methods: A Review", International Journal on Smart Sensing and Intelligent Systems., VOL. 10, NO. 2, June 2017, pp. 223-261.
- [2] Tsugunosuke Sakai, Haruya Tamaki, Yosuke Ota, Ryohei Egusa, Shigenori Inagaki, Fusako Kusunoki, Masanori Sugimoto, Hiroshi Mizoguchi, "Eda-Based Estimation Of Visual Attention By Observation Of Eye Blink Frequency", International Journal on Smart Sensing and Intelligent Systems., VOL. 10, NO. 2, June 2017, pp. 296-307.

- [3] Ismail Ben Abdallah, Yassine Bouteraa, and Chokri Rekik , “Design And Development Of 3d Printed Myoelectric Robotic Exoskeleton For Hand Rehabilitation”, International Journal on Smart Sensing and Intelligent Systems., VOL. 10, NO. 2, June 2017, pp. 341-366.
- [4] S. H. Teay, C. Batunlu and A. Albarbar, “Smart Sensing System For Enhanceing The Reliability Of Power Electronic Devices Used In Wind Turbines”, International Journal on Smart Sensing and Intelligent Systems., VOL. 10, NO. 2, June 2017, pp. 407- 424
- [5] SCihan Gercek, Djilali Kourtiche, Mustapha Nadi, Isabelle Magne, Pierre Schmitt, Martine Souques and Patrice Roth, “An In Vitro Cost-Effective Test Bench For Active Cardiac Implants, Reproducing Human Exposure To Electric Fields 50/60 Hz”, International Journal on Smart Sensing and Intelligent Systems., VOL. 10, NO. 1, March 2017, pp. 1- 17
- [6] P. Visconti, P. Primiceri, R. de Fazio and A. Lay Ekuakille, “A Solar-Powered White Led-Based Uv-Vis Spectrophotometric System Managed By Pc For Air Pollution Detection In Faraway And Unfriendly Locations”, International Journal on Smart Sensing and Intelligent Systems., VOL. 10, NO. 1, March 2017, pp. 18- 49
- [7] Samarendra Nath Sur, Rabindranath Bera and Bansibadan Maji, “Feedback Equalizer For Vehicular Channel”, International Journal on Smart Sensing and Intelligent Systems., VOL. 10, NO. 1, March 2017, pp. 50- 68
- [8] Yen-Hong A. Chen, Kai-Jan Lin and Yu-Chu M. Li, “Assessment To Effectiveness Of The New Early Streamer Emission Lightning Protection System”, International Journal on Smart Sensing and Intelligent Systems., VOL. 10, NO. 1, March 2017, pp. 108- 123
- [9] Iman Heidarpour Shahrezaei, Morteza Kazerooni and Mohsen Fallah, “A Total Quality Assessment Solution For Synthetic Aperture Radar Nlfm Waveform Generation And Evaluation In A Complex Random Media”, International Journal on Smart Sensing and Intelligent Systems., VOL. 10, NO. 1, March 2017, pp. 174- 198
- [10] P. Visconti ,R.Ferri, M.Pucciarelli and E.Venere, “Development And Characterization Of A Solar-Based Energy Harvesting And Power Management System For A Wsn Node Applied To Optimized Goods Transport And Storage”, International Journal on Smart Sensing and Intelligent Systems., VOL. 9, NO. 4, December 2016 , pp. 1637- 1667
- [11] YoumeiSong,Jianbo Li, Chenglong Li, Fushu Wang, “Social Popularity Based Routing In Delay Tolerant Networks”, International Journal on Smart Sensing and Intelligent Systems., VOL. 9, NO. 4, December 2016 , pp. 1687- 1709



- [12] Seifeddine Ben Warrad and OlfaBoubaker, "Full Order Unknown Inputs Observer For Multiple Time-Delay Systems", International Journal on Smart Sensing and Intelligent Systems., VOL. 9, NO. 4, December 2016 , pp. 1750- 1775
- [13] Rajesh, M., and J. M. Gnanasekar. "Path observation-based physical routing protocol for wireless ad hoc networks." International Journal of Wireless and Mobile Computing 11.3 (2016): 244-257.
- [14]. Rajesh, M., and J. M. Gnanasekar. "Congestion control in heterogeneous wireless ad hoc network using FRCC." Australian Journal of Basic and Applied Sciences 9.7 (2015): 698-702.
- [15]. Rajesh, M., and J. M. Gnanasekar. "GCCover Heterogeneous Wireless Ad hoc Networks." Journal of Chemical and Pharmaceutical Sciences (2015): 195-200.
- [16]. Rajesh, M., and J. M. Gnanasekar. "CONGESTION CONTROL USING AODV PROTOCOL SCHEME FOR WIRELESS AD-HOC NETWORK." Advances in Computer Science and Engineering 16.1/2 (2016): 19.
- [17]. Rajesh, M., and J. M. Gnanasekar. "An optimized congestion control and error management system for OCCEM." International Journal of Advanced Research in IT and Engineering 4.4 (2015): 1-10.
- [18]. Rajesh, M., and J. M. Gnanasekar. "Constructing Well-Organized Wireless Sensor Networks with Low-Level Identification." World Engineering & Applied Sciences Journal 7.1 (2016).
- [19] A. Almomani, B. B. Gupta, S. Atawneh, A. Meulenberg, and E. Almomani, "A Survey of Phishing Email Filtering Techniques," in iEEE Communications Surveys & Tutorials, vol. 15, pp.2070-2090, 2013.
- [20] S. S. Tseng, K. Y. Chen, T. J. Lee, and I. F. Weng., "Automatic content generation for anti-phishing education game," in iEEE International Conference on Electrical and Control Engineering, pp.6390-6394, 2011.
- [21] F. Frattolillo, "Watermarking Protocol for Web Context," in iEEE Transactions on Information Forensics and Security, vol.2, no.3, sept , pp.350-363, 2007.
- [4] P. Sun, and H. Lu, "An efficient web page watermarking Scheme," in iEEE, pp.163-167, 2009.
- [22] H. Wang and C. Liao, "Compressed-Domain Fragile Watermarking Scheme for Distinguishing Tamperers on Image Content or Watermark," in iEEE, pp.480-484, 2009.

M.Anto Bennet, B.Thamilvalluvan, C.A.Hema Priya, B.Bhavani and M.Shalini

Android based home automation and energy conservation

[23] A .P. Singh, V. Kumar, S. S. Senger, and M. Wairiya, "Detection and Prevention of Phishing Attack using Dynamic Watermarking," in VInternational Conference on Advances in Information Technology and Mobile Communication ,vol. 147, pp 132-137,2011.