

**Molecular and Functional
Characterization of the
IIIa Protein of
Porcine Adenovirus Type 3**

A Thesis

Submitted to the faculty of Graduate Studies and Research

in Partial Fulfillment of the Requirements for

the Degree of Master's of Science

in the

Department of Veterinary Microbiology

University of Saskatchewan

Saskatoon

By

Jill Andrea Van Kessel

PERMISSION TO USE

In presenting this thesis in partial fulfillment of the requirements for a postgraduate degree from the University of Saskatchewan, I agree that the libraries of this university may make it freely available for inspection. I further agree that permission for copying of this thesis in any manner, whole or in part, for scholarly purposes may be granted by the professors who supervised my thesis work or in their absence, the Head of the Department or the Dean of the college in which my thesis work was done. It is understood that any copying of publication or use of this thesis or parts thereof for financial gain shall not be allowed without any written permission. It is understood that due recognition shall be given to me and to the University of Saskatchewan in any scholarly use which may be made of any material in my thesis.

Request for permission to copy or to make other use of material in this thesis in whole or part should be addressed to:

Head of the Department of Veterinary Microbiology
University of Saskatchewan
Saskatoon, Saskatchewan S7N 0W0

ABSTRACT

The L1 region of the porcine adenovirus (PAdV)-3 genome encodes a protein of 622 amino acids named IIIa. Although it binds a neighboring group of nine (GON) hexons at the capsid level and cement the icosahedral shell that contains the viral DNA, little is known regarding its function with respect to viral life cycle. Moreover, the known location of IIIa protein in the capsid may help to express targeting ligands for altering the tropism of PAdV-3. The objective of this study was to characterize the IIIa protein of porcine adenovirus Type 3 (PAdV-3).

In order to characterize the IIIa protein, polyclonal antisera were raised in rabbits against different regions of IIIa. Anti-IIIa sera detected a specific protein of 70 kDa in PAdV-3 infected cells using Western blot assay. Immunofluorescence studies indicated that IIIa is predominantly localized in the nucleus of PAdV-3 infected cells. Analysis of PAdV-3 IIIa using antibodies specific for N- and C- terminal domains of the protein suggested that although the N-terminus and C-terminal domains of IIIa are immunogenic, they are not exposed on the surface of PAdV-3 virions. These results were further confirmed by our inability to isolate a chimeric PAdV-3 virion containing a heterologous protein fused to the N-terminus or C-terminus of IIIa.

Functional analysis suggested that IIIa may transactivate the major late promoter and down regulate the early region (E) 1A promoter. In order to locate the domains of IIIa responsible for different functions, in-frame deleted/truncated forms of IIIa were constructed. Analysis of the deleted/truncated forms of IIIa suggested that a) the sequences located between amino acids 273-410 and between amino acids 410-622b) affect the nuclear localization and transactivation function respectively.

Since protein- protein interactions are important for the biological functions of the protein, we determined the interaction of PAdV-3 IIIa with other viral proteins. IIIa was found to interact with DNA binding protein (DBP), E3 13.7 kDa protein, hexon, fiber, and pIX. These results suggest that PAdV3 IIIa may do more in the viral life cycle than merely act as cement between the hexons to maintain capsid stability and may actually be involved in regulating early to late gene transcription at appropriate stages during viral infection.

ACKNOWLEDGMENTS

I wish to sincerely thank Dr. Suresh Kumar Tikoo for expressing his confidence in my abilities and allowing me to pursue my Graduate degree under his supervision. I thank him for his expert guidance, discussions and valuable teaching.

I wish to sincerely thank Dr. Lorne A. Babiuk, my co-supervisor for his valuable suggestions and encouragements.

I would like to thank the members of my advisory committee, Dr. Lambert Loh, Dr. Lydden Polley and Dr. Vikram Misra for their thoughts, constructive criticisms and help during my program.

I am also grateful to the members (past and present) of the Vectored Vaccines research program at VIDO for their support, patience and help during my studies. In addition, I would like to thank Dr. Sam Attah-Poku for his help with peptide synthesis, Dr. Xiaoxing Li for providing plasmid pFPAV701, Dr. Alexander Zakhartchouk for anti-pIX sera, Joyce Sander and the administrative staff at VIDO for their help and support, the Animal Care unit for their help with antibody production, and Ms. Sarah Caldwell at the WCVM dept. of Biomedical Sciences for her help with electron microscopy.

Finally, I wish to dedicate this thesis to my husband Andrew, without whose encouragement, immeasurable love and support, I could not have completed my Graduate program. To my children, Jaelyn, Mitchel, and new baby Evan, I love you and thank you for being so patient with your Mom.

TABLE OF CONTENTS

PERMISSION TO USE.....	i
ABSTRACT.....	ii
ACKNOWLEDGMENTS	iii
TABLE OF CONTENTS	iv
LIST OF TABLES	vi
LIST OF FIGURES	vii
LIST OF ABBREVIATIONS	viii
1.0 REVIEW OF LITERATURE.....	1
1.1 Adenoviruses	1
1.1.1 Adenovirus taxonomy and classification	1
1.2 Human adenovirus.....	1
1.2.1 Structure and Organization of the Human Adenovirus Genome	3
1.2.2 Infectious Life Cycle	9
1.2.3 Adenovirus as a Vector.....	14
1.3 Targeting of Adenovirus.....	16
1.3.1 Need for targeting	16
1.3.2 Capsid protein modifications	17
1.4 Porcine Adenovirus.....	19
1.4.1 Classification	19
1.4.2 Porcine Adenovirus serotype 3	20
1.4.3 Porcine Adenovirus as a vector	25
2.0 INTRODUCTION.....	28
3.0 RESEARCH OBJECTIVES AND HYPOTHESIS	29
4.0 MATERIALS AND METHODS	29
4.1 Cell lines and Viruses.....	29
4.2 Antibody production.....	29
4.2.1 GST-Protein fusion	30
4.2.2 IIIa peptides.....	30
4.2.3 Immunizations.....	31
4.3 Radio- immunoprecipitation.....	31
4.4 Western blot analysis.....	32
4.5 Immunostaining	32
4.6 Immunogold Staining	33
4.7 Construction of IIIa deletion plasmids	33
4.7.1 Construction of plasmid IIIa.....	33
4.7.2 Construction of plasmid IIIaD1.....	33
4.7.3 Construction of plasmid IIIaD2.....	34
4.7.4 Construction of plasmid IIIaD3.....	34
4.7.5 Construction of plasmid IIIaD4.....	34

4.7.6 Construction of plasmid IIIa NLS.....	36
4.8 Transfection of plasmids encoding IIIa deletions and nuclear localization analysis.....	36
4.9 Yeast 2 Hybrid screening for viral protein: protein interactions.....	36
4.9.2. Construction of pGAD-AD vectors	36
4.9.3 Yeast two hybrid assay	38
4.10 Co-Immunoprecipitation.....	40
4.11 Transactivation Assays.....	40
4.11.1 Construction of pGL-MLP and pGL-E1A	40
4.12 Construction of recombinant PAdV-3 containing chimeric IIIa.....	43
4.12.1. Construction of plasmids.....	43
5.0 RESULTS	48
5.1 Analysis of PAdV-3 IIIa	48
5.1.1 Production of Antibodies.....	48
5.1.2 <i>In vivo</i> expression of IIIa	48
5.1.3 Western Blot analysis	51
5.1.4 Immunostaining	51
5.1.5 Detection of IIIa in mature capsids	51
5.2 Immunogold staining of PAdV-3 virions	55
5.3 Determination of the IIIa nuclear localization signal (NLS)	55
5.4 IIIa – protein (viral) interactions.....	59
5.4.1 Yeast 2 hybrid analysis of IIIa	59
5.4.2 Co-immunoprecipitation of viral proteins with PAdV-3 IIIa.....	62
5.5 Transcriptional Activation Assay.....	64
5.6 Construction of IIIa chimeric viruses	64
6.0 DISCUSSION	68
7.0 REFERENCES.....	73

LIST OF TABLES

Table 1.	Taxonomy of Adenovirus.....	2
Table 2.	List of primers for IIIa deletion constructs.....	35
Table 3.	List of yeast two hybrid primers.....	39
Table 4.	List of anti-PAdV-3 sera.....	41

LIST OF FIGURES

Fig. 1.	Transcription map of HAdV-5.....	5
Fig. 2.	Diagram of PAdV-3 capsid proteins.....	18
Fig. 3.	Transcriptional map of PAdV-3.....	21
Fig. 4.	Overlap extension pcr for deletion mutagenesis.....	35
Fig. 5.	Construction of Yeast two hybrid vectors.....	37
Fig. 6.	Construction of transactivation plasmids.....	42
Fig. 7.	Construction of PAdV-3 late region transfer vector.....	44
Fig. 8.	Construction of PAdV-3 recombinant transfer vectors.....	46
Fig. 9.	Homologous Recombination Schematic.....	47
Fig. 10.	PAdV-3 IIIa GST fusion protein expression.....	49
Fig. 11.	Immunoprecipitation using anti-IIIa sera.....	50
Fig. 12.	Western blot analysis of PAdV-3 infected cells.....	52
Fig. 13.	Analysis of cellular distribution of IIIa.....	53
Fig. 14.	Western blot analysis of PAdV-3 virions.....	54
Fig. 15.	Immunogold staining of PAdV3 virions.....	56
Fig. 16.	Schematic representation of PAdV-3 IIIa.....	57
Fig. 17.	Subcellular localization of mutant IIIa proteins.....	58
Fig. 18.	IIIa NLS analysis.....	60
Fig. 19.	Yeast two hybrid assay.....	61
Fig. 20.	Co-immunoprecipitation of PAdV-3 viral proteins.....	63
Fig. 21.	Transactivation assay.....	65
Fig. 22.	Transactivation assay using IIIa mutants.....	66
Fig. 23.	Schematic diagram of pFPAV 750 and pFPAV 751.....	67
Fig. 24.	Rescue of recombinant PAdV-3 IIIa virus.....	69

LIST OF ABBREVIATIONS

Å	Angstroms
Bp	Base pairs
BCIP	5-bromo, 4-chloro, 3-indolylphosphate
BGH poly A	Bovine growth hormone polyadenylation signal
BSA	Bovine Serum Albumin
CAR	Coxsackie-Adenovirus receptors
CPE	Cytopathic effect
CsCl	Cesium Chloride
DBP	DNA binding protein
FBS	Fetal bovine serum
GON	Group of nine hexons
GST	Glutathione-S-Transferase
HAdV	Human Adenovirus
HCMV	Human cytomegalovirus
InR	Initiator elements
IPTG	Isopropyl- β -thiogalactoside
ITR	Inverted terminal repeats
Kb	Kilobase pairs
kDa	Kilodalton
MCS	Multiple cloning site
MEM	Eagles minimum essential medium
MHC	Major histocompatibility complex
MOI	Multiplicity of infection
MLP	Major late promoter
MLTU	Major late transcriptional unit
NBT	Nitroblue tetrazolium
NLS	Nuclear localization signals
ORF	Open reading frame
PAdV	Porcine Adenovirus
PMSF	Phenylmethylsulfonylfluoride

PTA	Phosphotuncstic acid
pTP	Pre-terminal protein
PAGE	Polyacrylamide gel electrophoresis
PBS	Phosphate buffered saline
PCR	Polymerase chain reaction
RGD	Arginine-Glycine-Aspartate
RRRR	Four Arginine repeat
ScFVs	Single Chain Antibodies
SDS	Sodium dodecyl sulfate
TAF	Transcriptional activating factor
TPL	Tripartite leader

1.0 REVIEW OF LITERATURE

1.1 Adenoviruses

Adenoviruses, named after the original source of the tissue, adenoid, in which the prototype virus strain was discovered (Benko and Harrach, 2003; Davison et al., 2003), are non enveloped virus particles containing a linear double stranded DNA genome. Adenoviruses are icosahedral in shape, having a diameter of 70-90 nm, with 252 capsomers of which 240 are hexons and 12 are pentons. Adenoviruses infect a wide range of mammals, avian, fish and amphibian hosts, causing a variety of clinical syndromes.

1.1.1 Adenovirus taxonomy and classification

To date, more than 150 adenoviruses isolated from different mammals, birds, fish and amphibians have been grouped together in a single family named *Adenoviridae*. Initially, based on cross-reacting hexon antigens and host range, members of the family *Adenoviridae* were divided into two genera *Mastadenoviridae* (*infecting mammals*) and *Aviadenoviridae* (*infecting birds*). With the availability of DNA sequence data, two new genera have been proposed: *Atadenovirus* and *Siadenovirus* (Benko and Harrach, 2003; Davison et al, 2003; Kovacs et al, 2005; Schrenzel et al, 2005). *Atadenoviruses* were named as a consequence of the high A+T content of their respective genomes. They infect various ruminant, avian, marsupial, and reptilian hosts. *Siadenoviruses* were named as they encode a protein similar to bacterial sialidases. They have the lowest G+C (39%) content of all the adenoviruses. The only known fish adenovirus falls into a fifth clade that as yet has no other members (Davison et al, 2003). Table 1 gives an overview of adenovirus taxonomy and groupings.

1.2 Human adenovirus

Human adenovirus (HAdV), a member of *Mastadenovirus*, was first isolated in 1950's. Currently 51 serotypes of HAdVs are known which are classified into 6 subgenera A to F (Crawford-Miksza et al. 1996). Depending on serotype, replication occurs in the upper respiratory tract, the gut epithelium and the ocular membranes. Although most infections are subclinical, young children or those who are

Table 1. Taxonomy of Adenovirus.

	Mastadenovirus	Atadenovirus	Siadenovirus	Aviadenovirus
Subgroups	PAdV1-5	Egg Drop Syndrome	Frog AdV	Fowl AdV-1(CELO)
	Shrew AdV	Bovine AdV-1	HEV	Fowl AdV-10
	Human AdV-2	Caprine AdV		Falcon AdV
	Human AdV-3	Ovine AdV-287		
	Human AdV-4	Possum AdV		
	Human AdV-5	Corn Snake AdV		
	Equine AdV-1			
	Equine AdV-2			
	Canine AdV-1			
	Canine AdV-2			
	Bovine AdV-3			
	Murine AdV-1			
	Simian AdV's			
	Caprine AdV1,2			

(Adapted from Schrenzel et al, 2005). The table groups the subspecies of adenoviruses identified to date. Those adenoviruses that are as yet termed unclassified as well as the numerous subspecies within the subgroups are not shown.

immunocompromised may exhibit symptomatic infections such as a mild cold or conjunctivitis.

As HAdV-2 and -5 are the most widely studied, the majority of the background information pertaining to adenoviruses will address the characterization carried out on these two serotypes.

1.2.1 Structure and Organization of the Human Adenovirus Genome

HAdV- 2 and -5 fall into species C (Wadell, 1984; Mei et al., 2003). The HAdV-5 genome has a G+C content of 55.2% and nucleotide composition of 27.7% G, 28% C, 23.3% A, and 21.5% T (Mei et al. 2003). The genome of HAdV-5 is organized into complex transcriptional units, which can be divided into early (E) and late (L) regions based on the onset of viral DNA replication. Moreover, both DNA strands are involved in the transcription of different mRNAs. The four early regions (E1-E4) produce multiple differentially spliced mRNAs, which encode a variety of distinct regulatory proteins required to establish an optimal environment for efficient viral DNA replication and subsequent late gene expression. This is followed by DNA replication, which begins at each of two identical replication origins on each end of the viral genome termed the right and left inverted terminal repeats (ITR). Replication is carried out via strand displacement from both the right and left hand strands of DNA. The intermediate regions are transcribed both early and late in infection, from both the right and left strands of viral DNA. The five late regions, L1-L5, are transcribed after the onset of DNA replication, and encode mainly structural proteins. In addition, there are cis-acting packaging motifs that are present on one end of the genome to direct the encapsidation of the viral DNA into the newly formed capsids. Figure 1 shows the general organization of the transcriptional map of HAdV-5.

1.2.1.1 Early Regions

The E1 region encodes E1A, E1B^{small} (E1B19K) and E1B^{large} (E1B55K) proteins, which are responsible for transactivation of viral and cellular genes, transformation of cells in culture, induction of cellular DNA synthesis, and inhibition of apoptosis and mitotic cell division (Hoffmann et al., 2005). E1A facilitates viral propagation by sequestering tumor suppressor proteins which in turn results in induction of cells into S-phase of mitosis (Madison et al, 2002). E1B19K is a functional

homologue of the anti-apoptotic cellular protein Bcl-2 which is antagonistic for pro-apoptotic proteins Bax and Bak (Madison et al, 2002). The E1B55K protein binds and inactivates p53 and together with the E1B^{small} protein, maximizes viral replication by preventing premature cell death (Rao et al. 2004).

The E2 region is made up of E2A and E2B, which are required for viral DNA replication. E2A encodes the DNA binding protein (DBP) whose carboxy terminal domain is involved in DNA binding, initiation and elongation phases of DNA replication as well as transcriptional control of the major late promoter (MLP). It is also thought to function in conjunction with viral proteins IVa2, 52K and others to package newly synthesized viral DNA into capsids (Russel, 2000; Casper et al, 2005). E2B encodes a DNA polymerase as well as the pre-terminal protein (pTP). pTP is thought to be involved in protein primed initiation of DNA replication as well as a primary player in liver toxicity of first generation adenovirus vectors (Everett et al. 2003; Mysiak et al, 2004a).

The E3 region encodes proteins, often termed “stealth” proteins, that are important in escape from host immune responses, allowing the virus to persist longer in the cells. They are involved in downregulation of MHC I, prevention of apoptosis by down-regulation of apoptotic proteins like FAS and TRAIL, inhibition of arachidonic acid secretion and inhibition of TNF-induced apoptosis (Horwitz 2004). The E3 region also encodes the adenovirus death protein (ADP) in HAdV-5, which assists in host cell death and efficient release of progeny virus. The ADP is not present in all human adenovirus serotypes (Russel 2000).

The E4 region encodes proteins that have been shown to affect transgene persistence, vector toxicity and immunogenicity (Weitzman et al, 2005). Proteins from the E4 genes can modulate transcription, the cell-cycle, cell signaling and DNA repair. In addition, some of these proteins also cause oncogenic transformation (Weitzman et al, 2005).

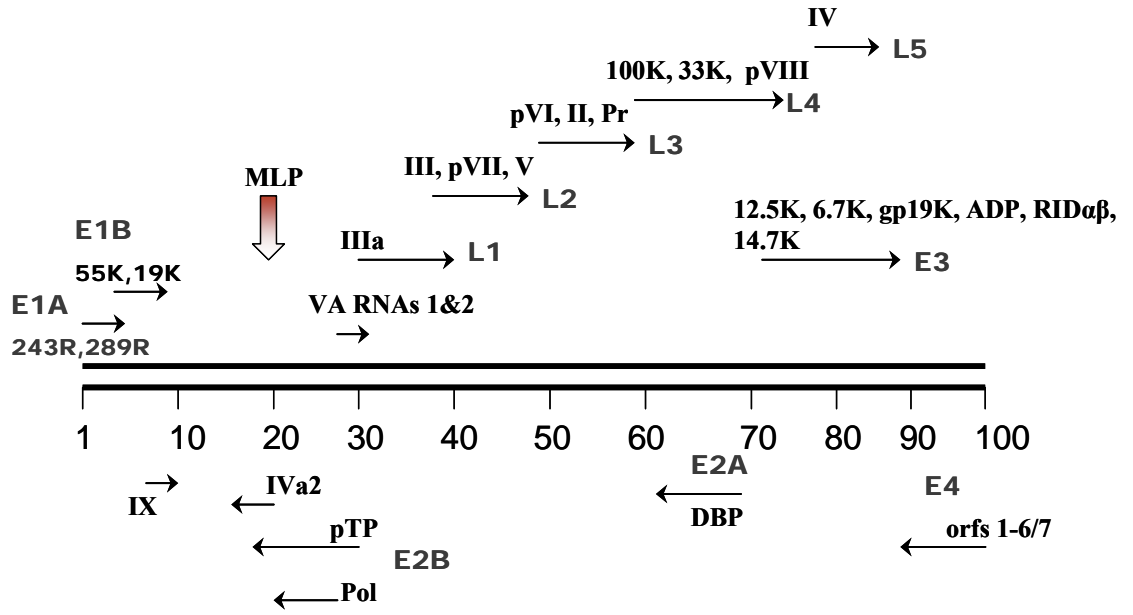


Figure 1. Transcriptional Map of HAdV-5. (Adapted from Russel, 2000).
 Arrows indicate the direction of transcription and the gene locations within the genome.

1.2.1.2 Late Regions

In HAd- 2 and 5 there are five late regions, L1 to L5, which encode the majority of the structural proteins. All late gene transcripts contain the tripartite leader (TPL) and are transcribed from a common major late promoter (MLP) (Russel, 2000).

In the L1 region, two mRNA's have been identified which correspond to 52K and IIIa. 52K is a nuclear protein, important for assembly of new virions via interactions with DBP and IVa2 to package viral DNA in the capsid. (Russel , 2000; Ostapchuk et al, 2005). IIIa is a minor cementing protein that interacts with hexon molecules joining one group of nine (GON) hexons with the neighboring GON in the icosahedral capsid. It is a phosphoprotein, phosphorylated by endogenous protein kinases and may play other roles during viral infection. Its transcription is tightly regulated and early expression results in down-regulation of its co-transcript 52K as well as other late viral genes (Molin et al., 2002)

The L2 region encodes pIII or penton base, pV, pVII and mu (pX). The penton base protein has been extensively studied as it is integral to early binding and virus entry into the cell and is also thought to play a role in cementing the hexon and fiber proteins together at the 12 vertices of the capsid (Bai et al, 1993; Russel 2000). Next to hexon, it shows the highest homology to penton base proteins of other adenoviruses. Human adenoviruses have a conserved RGD (Arg-Gly-Asp) motif at the apex of two alpha helices contained within the penton base proteins. This sequence promotes efficient uptake of virus into the cellular endosomes by interacting with $\alpha 5\beta 3$ integrins (Bai et al, 1993). The pV protein links the viral DNA protein complex to the inside of the capsid (Matthews et al. 2001) as well as interacts with core protein mu to organize the viral DNA into nucleosome-like structures in the mature virion (Zhang et al, 2005). The core protein mu or pX has been studied with respect to disruption of the nucleolar regions of cells due to its arginine-rich amino acid composition and the presence of nucleolar targeting signals similar to those found in pV (Matthews, 2001; Lee et al, 2004). pVII is a core protein that accounts for 10% of the protein mass of the virion. pVII is very rich in basic amino acids, which facilitates the condensation of viral DNA as it is packaged in a manner similar to cellular histones (Lee et al., 2003). The mechanism for packaging such chromatin-like DNA into the virus is unclear as it does not agree with the phage

models for packaging DNA. It is unclear if pVII is packaged along with viral DNA or separately.

The L3 region codes for pVI, hexon and the 23 kDa protease. pVI is a minor capsid protein that has an important function in disruption of endosomal membranes to release virus to the cytosol (Wiethoff et al., 2005). The 23kDa protease functions in the proteolytic cleavage of viral proteins during capsid maturation. The protease deleted HAdV-5 can only undergo one round of replication in permissive cells. As the protease appears to be conserved throughout most serotypes, its function of processing of viral proteins during disassembly and assembly of infectious virions also appears to be conserved (Nakano et al, 2000; Russel, 2000; Weithoff et al, 2005). Hexon is the most abundant protein in the mature virus capsid (240 copies per virion). It is the major antigenic protein and thus is the major inducer of neutralizing antibodies (Wohlfart et al, 1988). Each hexon capsomer is trimeric and has a pseudo-hexagonal base and a triangular top (Athappilly et al, 1994). Hexon has recently been shown to be important in viral attachment by binding to cellular phospholipids permitting viral entry independent of primary and secondary cellular receptors (Hong et al, 2005). It is also the only major structural protein of the incoming adenovirus that docks at the nuclear pore complex and can be partially imported into the nucleus to facilitate viral DNA delivery (Greber et al, 1993; Saphire et al, 2000). In gene therapy applications involving HAdVs, it is desirable to circumvent neutralization, thus much research has been done attempting to modify the hexon protein prolonging viral persistence in the body. This “immune escape” mechanism is advantageous for transgene expression by adenoviral vectors (Roy et al., 2005)

The L4 region codes for the 100K, 33K, and pVIII proteins. The 100K protein plays an essential role in the trimerization of hexons and acts as a scaffolding protein (Cepko and Sharp, 1983; Morin and Boulanger, 1986; Hong et al, 2005). Moreover, the 100K protein is associated with ribosomes or polyribosomal viral RNA, can bind RNA *in vivo* and is not found in mature virions (Riley and Flint, 1993). Its proposed function as a chaperone protein and has been found to be essential for efficient translation of late but not early viral mRNAs (Hayes et al, 1990). The direct selection of late mRNAs for translation by 100K is suggested to be the result of export of newly synthesized viral

mRNA's from the nucleus to the cytoplasm rather than sequence specific recognition of viral mRNA's (Riley and Flint, 1993). The 33K protein is thought to function as a scaffolding protein and is essential for virion assembly. Carboxy-terminal truncations of the 33K protein aborted assembly of mature virions (Finnen et al, 2001). More recently this protein has been implicated in the transcriptional switch from early to late genes by activating transcription from the major late transcription unit (MLTU) (Fessler and Young, 1999; Farley et al, 2004). pVIII is a hexon associated structural protein that connects the core with the inner surface of the adenovirus capsid. It was previously thought to be present only in empty capsids (Vellekamp et al, 2001). Recently, however, it has been suggested that pVIII is positioned underneath IIIa, connecting the inside of the capsid to hexons between the GON (Fabry et al, 2005), a function previously attributed solely to IIIa.

The L5 region encodes the fiber gene, which is integral for binding of the adenovirus to permissive cells. Fiber is a structural protein that projects from the 12 vertices of the icosahedral capsid. Its structure is comprised of a variable number of species-specific shaft repeats and is bound to the penton base at the amino terminus. The carboxy terminus, important for attachment, is made up of a trimerized knob domain with a three-bladed propeller structure surrounding a central surface depression (Henry et al, 1994). The knob region has been exploited as a potential site for insertion of ligands for use in adenovirus targeting (Dmitriev et al., 1998; Belousova et al., 2002). The fiber knob monomer is composed of 2 β -sheets sandwiched together with loops and turns connecting them. The sheets seem to be functionally separate with the "R" sheet important for receptor recognition and the "V" sheet involved in trimerization. (Henry et al., 1994; Xia et al., 1994).

1.2.1.3 Intermediate regions

The intermediate genes are transcribed both before and after onset of viral replication. The intermediate regions of HAdV code for two structural proteins IVa2 and pIX. The IVa2 protein is known to activate the major late promoter (MLP) by binding downstream elements (DE) as either a functional homodimer of IVa2 called Def B or as a heterodimer (one copy of IVa2) called Def A (Zhang et al, 2000). It has been suggested

to also interact with adenovirus packaging domains, in a serotype specific manner (Zhang et al, 2000). Because IVa2 binds homologous sequences shared by both the A repeats found in the adenovirus packaging domains, and the DE of the MLP, it is supposed that IVa2 has direct involvement in the packaging of viral DNA (Zhang et al, 2001; Zhang and Imperiale, 2003; Ostapchuk et al, 2005; Perez-Romero et al., 2005).

Polypeptide IX, thought to function as a trimer, is present on the viral capsid and is used as cement to hold the hexons together within the GON. It has been reported to be a transactivator as well as as playing a role in the reorganization of host cell nuclear domains (Lutz et. al. 1997; Rosa-Calatrava et al., 2001; Parks, 2004; Sargeant et al., 2004). More recently, it has been used as a putative site for insertion of targeting ligands or therapeutic genes due to its position on the adenovirus capsid (Dmitriev et al., 2002; Zakhartchouk et al, 2004).

1.2.2 Infectious Life Cycle

The adenovirus infectious cycle can be divided into two phases. The first or “early” phase includes the virus entry into the cell followed by the passage of the viral genome to the nucleus. Selective transcription and translation of early genes modulates the cellular machinery to facilitate the replication of the viral DNA and the transcription and translation of late genes in the second or “late” phase. This leads to assembly of structural proteins in the nucleus and the maturation of infectious virus.

1.2.2.1 Viral attachment

Attachment of virus to cellular receptors involves high affinity binding of the fiber knob domain to cell surface molecules, which differ depending on adenovirus serotype. Human subgroup C adenoviruses (HAdV-2 / -5) bind preferentially to the Coxsackie Adenovirus receptor (CAR) present on many cell types (Dmitriev et al, 1998). Interestingly, HAdV-2 and 5 can also manifest CAR-independent attachment through heparin sulfate glycosaminoglycans (Dechecci et al., 2001; Zhang et al., 2005). In contrast, HAdV-3, a member of group B utilizes CD46 (a membrane cofactor protein) as well as CD80 and CD86 (known for T-cell activation) as receptors (Zhang et al., 2005; Martilla et al., 2005). Several group D viruses attach via sialic acid residues, a

carbohydrate commonly found on glycoproteins and glycolipids (Arnberg et al, 2000, 2002). Although integrins are known to play a role in internalization of the adenovirus, fiber deleted adenovirus has been shown to mediate attachment through $\alpha M\beta 2$ and $\alpha L\beta 2$ integrins (Huang et al. 1996). In addition, it has been reported that HAdV-5 also binds MHC class I molecules (Hong et al, 1997).

1.2.2.2. Entry and Uncoating

Following attachment of the adenovirus fiber to its receptor, the penton base of HAdV-5 interacts with $\alpha v\beta 3$ and $\alpha v\beta 5$ integrins present on many cell surfaces, facilitating virus penetration into the host cell (Nakano et al, 2000). The integrins contribute to the permeabilization of the plasma membrane most probably due to clathrin coated pits (Wang et al., 1998). The integrins also play a role in activating the ERK 1 and 2 protein kinase pathways via various signaling molecules affecting the virus uptake and intracellular transport (Nakano et al, 2000; Russel 2000). Also essential for fiber release is the underlying cellular actin cytoskeleton as cells treated with actin-destabilizing agents show strong inhibition of fiber release. (Nakano et al, 2000) The primary receptor, as determined by the fiber, is the key factor in virus tropism and targeting studies (Leopold et al, 1998), but the secondary receptor plays a more subtle and less understood role in the infectious life cycle of the virus. Following the uptake of an adenovirus particle and formation of the primary endosome, there is reported loss of capsid proteins, most notably hexon, penton base, IIIa and pVI (Weithoff et al, 2005). The change in pH inside the endosome causes some conformational changes in the minor cementing capsid proteins, which may expose hydrophobic residues on the proteins. These residues are then thought to interact with and reorganize the membrane bilayer to allow the escape of the viral DNA and partially uncoated virus. The pVI protein appears to play a significant role in membrane disruption of the endosome due primarily to the presence of an amphipathic α -helix (Weithoff et al, 2005).

1.2.2.3 Nuclear Translocation

Following endosomal escape, the uncoated viral proteins and DNA are translocated to the nucleus for replication of the viral genome. This is thought to be due in part to the $\alpha_V\beta_V$ integrins which, after binding the penton base early in infection activate small intracellular signaling molecules such as Rho, Rac and Cdc42 GTPases. As well, integrins can act via actin fibers to facilitate endocytic pathways and motility (Sanlioglu et al, 2000). It has been shown that a key factor in nuclear targeting of HAdV-2 is the minus end-directed motor complex, dynein/dynactin. The viral DNA facilitates its translocation to the nucleus by remaining wrapped in the viral capsid, moving along microtubules, until arrival at the nuclear pore complex (Suomalainen et al, 1999). Interestingly, if viral DNA core structures, lacking the remainder capsid components, are microinjected into cells, the DNA remains aggregated in the cytoplasm (Suomalainen et al, 1999). It is not clear if microtubules are directly involved with nuclear translocation by interacting directly with structural components of the virus (Suomalainen et al, 1999) or the virus is transported along microtubules with other cellular proteins (Leopold et al., 1998) as destabilization of microtubules slows but does not completely eliminate adenovirus nuclear translocation (Suomalainen et al, 1999). It has been shown that intact naked capsids of adenovirus accumulate around the periphery of the nuclear membrane near the nuclear pores (Suomalainen et al, 1999) but intact capsids cannot enter the nucleus thus suggesting that dismantling of the capsid is required for viral nuclear entry. (Leopold et al, 1998; Greber and Fassati, 2003; Wodrich et al., 2003; Meier and Greber, 2004; Wiethoff et al., 2005). The viral particle undergoes further disassembly at the nuclear pore complex followed by translocation of the DNA into the nucleoplasm where viral transcription takes place. Although most of the adenovirus proteins move to the nucleus, very few actually contain nuclear localization signals (Kasamatsu, 1998). It is hypothesized that they may move along with other viral or cellular proteins in a “piggyback” fashion. This has been demonstrated by Wodrich et al., 2003, where they show nuclear import of hexon in cultured cells is facilitated by protein VI. In that study, it is suggested that pVI provides an adaptor for hexon import by forming a complex with import receptors importin α/β and directing nuclear import via the importin α/β pathway.

1.2.2.4 Transcription, Replication and Viral Egress

Once in the nucleus, transcription of selected regions of viral DNA termed the “early regions” starts. The E1 genes are transcribed first, producing E1A and E1B proteins. E1A proteins interfere with the processes of cell division as well as the regulation of NF- κ B and p53 in promoting oncogenesis and transformation. E1B proteins include an analogue to the cellular Bcl-2 gene, which interacts with the BAX family of proteins to interfere with apoptosis and necrosis of cells (Madison et al, 2002). Next, E2 genes are transcribed producing E2 proteins. E2 proteins provide the machinery for the replication of viral DNA and subsequent transcription of the late genes. This is followed by the transcription of E3 genes. The E3 proteins are responsible for diverting the host immune defense mechanisms. Gp19K protein binds to MHC class I to prevent cell surface antigen expression as well as delaying MHC class I expression (Bennet et al., 1999; Horwitz 2004). E3 proteins prevent apoptosis by down-regulation of apoptotic proteins like FAS and TRAIL, inhibition of arachidonic acid secretion and inhibition of TNF-induced apoptosis (Horwitz 2004). In addition, E3 genes encode the adenovirus death protein (ADP) which promotes virus release, RID α and β as well as 14.7K which work to block proapoptotic pathways (Russel, 2000). Finally, E4 genes encode E4 proteins that interact with p53, block apoptosis and are involved in processing of viral mRNA to promote virus DNA replication and inhibit host protein synthesis (Russel, 2000; Weitzman et al., 2005).

Replication of the HAdV-5 viral genome involves a unique protein priming mechanism. Initially, three viral proteins, the precursor terminal protein (pTP) that serves as a primer, the adenovirus DNA polymerase (pol) and DNA binding protein (DBP) as well as two cellular proteins, nuclear factor I (NFI) and octamer-binding protein (Oct-1) form a pre-initiation complex that binds to the origin of replication (Mysiak et al, 2004a). The origins of DNA replication are located at each end of the DNA within 103 bp long inverted terminal repeats (ITR) (Mysiak et al, 2004a). pTP and pol form a stable heterodimer in solution and bind as a complex in the conserved core origin. pTP is covalently bound to the 5' ends of the double stranded linear genome. Following the complex binding and initial addition of nucleotides, pTP dissociates and pol elongates the newly synthesized DNA strand. Later in viral infection, pTP is cleaved by a viral

protease at three specific cleavage sites resulting in the formation of a smaller terminal protein that stays attached to each DNA end for the remainder of the viral life cycle (Mysiak et al, 2004b).

The intermediate regions, encoding structural proteins IVa2 and pIX, are transcribed both early and late in infection. These proteins are important for transcriptional activation of early genes as well as activation of the major late promoter which is critical for transcription of late genes (Russel, 2000; Parks, 2004; Vellinga et al., 2005; Zhang et al., 2005).

Finally, transcription of HAdV-5 late genes starts with regions L1 to L5. Following a series of complex splicing events, late viral transcripts are generated which are translated into the structural and non-structural components facilitating formation of progeny viral capsids in the nucleus. The virus capsid contains at least nine proteins of which hexon, penton base and fiber are termed major capsid proteins and IIIa, pVI, pVIII and pIX are termed minor capsid proteins. The other four viral proteins, pV, pVII, pX and pTP are packaged with the new viral DNA in the viral core (Vellinga et al, 2005). The precursor capsid undergoes a maturation process as the DNA is packaged to become a mature virion (Teschke et al, 2003).

The encapsidation of the newly synthesized viral DNA is driven via the cis acting packaging domain present on the left end of the genome (Benson et al, 2004). The packaging region contains 7 functionally redundant repeats called “A” repeats that contain a consensus motif (Zhang and Imperiale, 2003). It is hypothesized that the packaging process for adenoviruses harkens back to a common pathway shared with its distant relative the bacteriophage (Benson et al, 2004). There are compelling structural similarities between the Ad capsid (hexon) proteins and the PRD1 bacterial phage protein (P3 coat protein) (Benson et al, 2004). The packaging process for HAdV-5 involves formation of a procapsid which is sufficient for packaging of the viral DNA (Teschke et al., 2003). The assembly of procapsids is thought to proceed through direct protein: protein interactions, hydrophobic or ionic protein interactions, or with additional energy input from ATP (Teschke et al., 2003). Double stranded DNA viruses seem to have morphogenesis in common as adenoviruses, herpesviruses and dsDNA bacteriophages undergo maturation from a precursor capsid to a mature capsid structure (Teschke et al.,

2003). Composed primarily of structural and non-structural (scaffolding) proteins, the procapsid is recognized by viral DNA likely via proteins bound to the packaging domain. Models for packaging involve the DNA entering the procapsid using a portal located at a vertex of the icosahedron. Analogous to the bacteriophage packaging, it is thought that the viral DNA is moved into the procapsid using an ATP-driven motor (Benson et al, 2004). The core proteins V, VII and mu are associated with the packaged DNA in a mature virus particle. It appears that neither the ITR's nor the terminal protein are essential for packaging of viral DNA as deletion mutants for one or both ITRs and terminal proteins were found to be packaged with nearly the efficiency of wild type virus (Ostapchuk et al., 2003). What is essential for packaging are the number of A-T rich "A" repeats, situated in close proximity to the end of the viral DNA (within ~600 bases from the terminus) (Russell, 2000). These events are followed by nuclear infrastructure changes to permeabilize the nuclear membrane and facilitate egress of the virus into the cytoplasm. Subsequent movement to the cell periphery is thought to be accomplished in a plus-ended microtubule motor-dependent fashion as shown by Suolomalainen et al, 1999. Finally, the daughter viruses are released by lysis of infected cells.

1.2.3 Adenovirus as a Vector

Many biological properties of adenoviruses make them a logical choice as a vehicle for transgene delivery (Curiel, 1999) for vaccination or transgene therapy for neurological illness, autoimmune disorders, allergies and regeneration of tissues. They include a) transduction of a wide variety of cells both actively dividing and quiescent, b) large capacity for incorporation of heterologous DNA, (Romano et al, 1999), c) virion stability *in vivo* and d) non-oncogenicity in humans (Belousova et al, 2002). Although adenoviruses are attractive due to their "needle free" delivery and antigen presentation design which mimics a natural infection, there remains many obstacles to overcome.

First generation adenovirus vectors usually involve deletion or inactivation of the genes in the E1 region, which are responsible for early DNA replication events and have been shown to transform cells in culture (Graham, 1977; Russel, 2000). Removal of E1 results in transcriptional inactivation of the E2 genes which causes impairment of the replication of viral DNA and viral capsid proteins. Although E1 deleted vectors can be

propagated to high titers *in vitro* by growth on E1 complementing cell lines (Graham et al. 1977), they can not replicate *in vivo*. Unfortunately, use of these vectors resulted in strong immune responses to the vector backbone as well as toxicity caused by the virus itself (Everett et al. 2003; Schaack, 2005). Because wild-type virus exists ubiquitously in the population, there is also a chance of spontaneous recombination events between wild-type and recombinant virus. Moreover, most individuals have pre-existing immunity to HAdV-2 and HAdV-5 based vectors, thus neutralizing the virus before any therapeutic gene delivery (Amalfitano et al., 1998; Amalfitano and Parks, 2002).

Second generation adenovirus vectors are additionally deleted for some or all of the E2 genes resulting in replication-deficient adenovirus. Moreover, multiple deletions decrease the chances of spontaneous recombination events capable of generating replication competent adenovirus (Gorziglia et al, 1999). An additional advantage over E1 deleted vectors is the decreased production of late proteins which reduces epitope expression and recognition by the immune system of second generation vectors (Lusky et al, 1998).

Third generation adenovirus vectors involve deletion of E1/E3 and some E4 genes that are non-essential for replication *in vitro*. Foreign genes can be expressed in the place of the deleted viral genome sequences (Lusky et al., 1999; Gorziglia et al., 1999). Recently, it has been shown that while E3 is non-essential for replication, its re-introduction can enhance transgene expression in oncolytic viruses as compared to the E3 deleted counterparts (Zhu et al., 2005).

More recently, adenovirus vector improvement has seen the development of “gutless” adenovirus vectors deleted of all genes except those required for replication and packaging. Gutless vectors are to date, the safest and most efficient gene transfer vectors based on adenoviruses (Catalucci et al., 2005). The current system for propagation of gutless or “helper-dependent” (HD) virus requires an E1 complementing cell line, the helper dependent viral backbone and a helper virus that provides all of the viral proteins *in trans* necessary for viral replication and assembly of HD progeny (Barjot et al., 2002; Fleury et al., 2004). The only problem with propagation of HD virus vectors is a residual contamination of helper virus in the gutless vector population. To overcome this, the cre-lox P recombinase system was developed. Briefly, in this system, the helper virus

packaging domain is flanked by loxP sites and is efficiently excised by cre recombinase (expressed in E1 complementing cell line) *in vitro* to yield an “unpackable” helper virus that still produces the necessary proteins for HD virus growth. Although the helper virus contamination is greatly reduced using the cre-loxP system, the gutless virus preparations are never helper virus free, which undermines their therapeutic use. Another method used to generate gutless vectors involves episomal replication of vector genomes. Such systems require a) correct full length replication of both DNA strands and b) circular episomes must replicate in a cell-cycle controlled manner with proper segregation of replicated genomes (Kreppel and Kochanek, 2004). To achieve this, a binary system is used involving two vectors, one containing a site-specific recombinase and the other containing recognition sites for the recombinase in a direct orientation. Following cotransduction of cells with both vectors *in vitro*, the recombinase is excised and circularizes the DNA located in between the recognition sites. This generates circular episomes containing origins of replication and encoding proteins directing segregation to allow cell-cycle controlled expression of inserted transgene (Ehrhardt et al., 2003; Kreppel and Kochanek, 2004).

1.3 Targeting of Adenovirus

1.3.1 Need for targeting

As HAdV-5 transduces a wide variety of cell types, this makes it an attractive choice if there is need for transgene expression in many different tissues. However, in the case of cancer gene therapy or delivery to antigen presenting cells, there is a requirement for narrow tropism so only affected cells are transduced by a recombinant vector. The lack of target specificity of adenovirus vectors is a direct consequence of the molecular recognition events that go on early in the infection. Moreover, some cells do not express receptor(s) required for efficient transduction by HAdV-5 such as bronchial epithelium, smooth muscle, endothelium, macrophages and T-cells (Wickham et al, 1999). It has been shown that adenovirus binding to CAR has a threshold effect where expression of the receptor below a certain level renders the cells refractory to infection. (Freimuth P, 1996) Many cell types including cancer cells express CAR at suboptimum levels making transduction by CAR-dependent vectors inadequate (Hemmi et al, 1998; Li et al., 1999;

Miller et al., 1998). Thus, by altering the tropism of adenovirus, it should be possible to develop a vector which can specifically transduce cells of interest. Introducing novel tropism is based on engineering adenovirus vectors that bind to alternate cellular receptors expressed on the desired cellular targets. Incorporation of cell-specific ligands into the viral coat proteins could allow specific delivery of transgenes to tissues while those normally susceptible to infection would not be affected.

1.3.2 Capsid protein modifications

To date, modifying the native adenovirus tropism to specifically target the cells or tissue of interest has involved the genetic modification of the major capsid proteins, namely hexon, penton and fiber, by incorporating targeting ligands (Fig. 2). The main sites for insertion of ligands have been the HI loop of fiber knob (Einfeld et al,1999; Belousova et al, 2002), the hypervariable region of hexon loop L1(Wu et al., 2005) and the RGD-motif loop of penton base (Einfeld et al., 1999; Mizuguchi et al. 2001). Limitations to this approach stem from the insertional size constraints and improper folding of proteins. As well, aberrant cell signaling may occur if the RGD motif is mutated on pentons resulting in improper interactions with integrins and subsequent reduced viral replication (Bai et al, 1993).

Another strategy for altering viral tropism has been fiber replacement or “fiber swapping” where the native fiber gene is replaced with the sequence encoding the fiber gene from another adenovirus serotype that displays a different tropism (Krasnykh et al., 1996; Wu and Tikoo, 2004). Several groups have reported successful production of HAdV-5 virions containing the native fiber shaft domain coupled to the knob region of HAdV-3 for tumor cell transduction (Krasnykh et al., 1996; Stevenson et al., 1997; Kawakami et al., 2003) In a similar vein, vectors containing chimeric HAdV-5 and HAdV-35 fiber proteins were shown to greatly enhance the transduction of human placental cell lines *in vitro* and thus may prove a useful tool for delivery of transgenes to trophoblast cells (Koizume et al, 2004). It is known that species B serotypes use the lysosomal pathway, which is thought to be advantageous as delayed escape from this compartment may help the virus to be transported within these structures through the cytoplasm to the nucleus. Using a chimeric HAdV-5 vector that carries the fiber protein

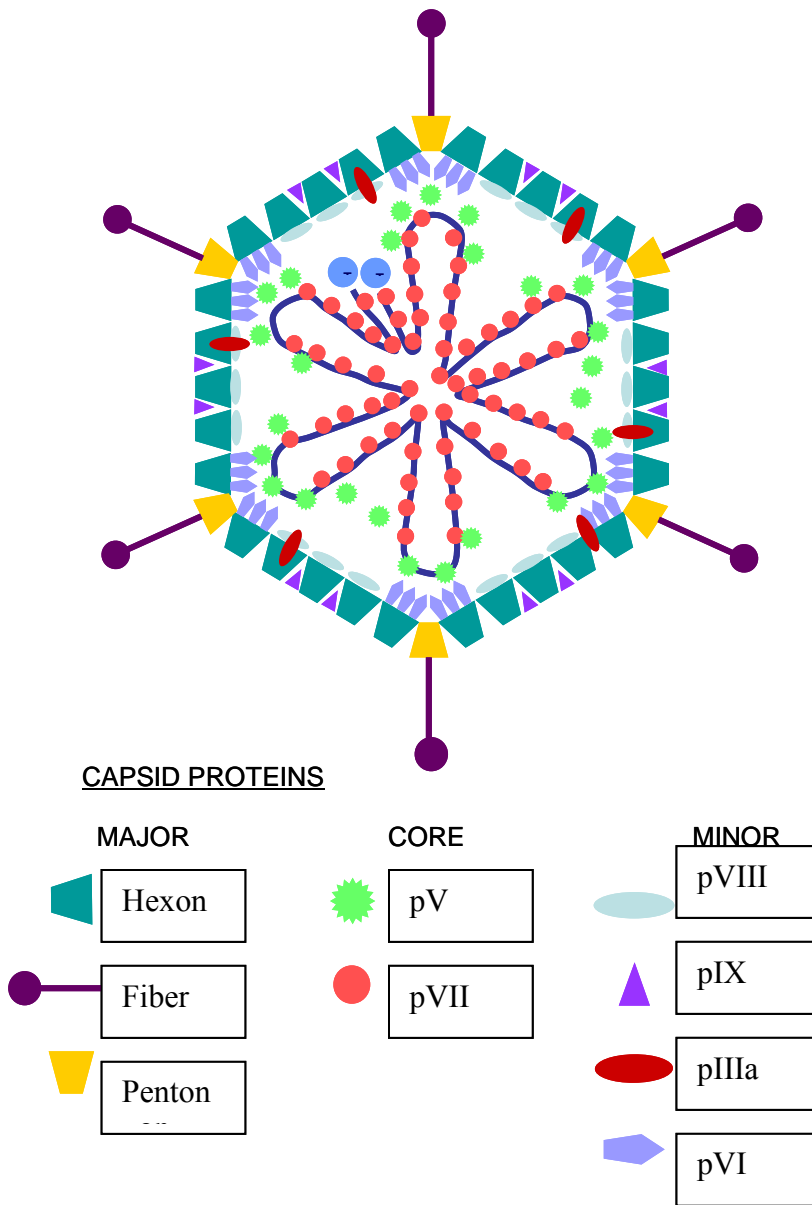


Fig. 2. Illustration of adenovirus major and minor capsid proteins (Adapted from Russel , 2000).

of HAdV-7, which is targeted to the lysosomal pathway, the transgene delivery efficiency of this pathway was enhanced (Miyazawa et al. 1999; Miyazawa et al. ,2001).

Another approach has involved binding of protein bridges to the viral capsid to direct viral attachment such as the Fc binding domain of *Staphylococcus aureus* protein A to form a vector-ligand targeting complex when coupled with a specific antibody for the desired target (Kouokhov et al, 2003).

A current strategy to target diseased tissues and tumor cells directly has been to incorporate a tumor-specific ligand, such as human CD40 ligand (CD154), directly into the adenovirus fiber knob molecule (Belousova et al., 2003). The gene encoding the protein of interest is inserted into the ORF of fiber/knob such that it would be expressed on the surface of the virus (Dmitriev et al., 1999). Several groups have reported recombinant virus containing chimeric fiber proteins for specific targeting of cell populations (Wickham et al., 1997; Dmitriev et al., 1999; Douglas et al., 1999; Einfeld et al, 1999; Wu and Tikoo, 2004; Joung et al., 2005).

More recently, the minor capsid protein pIX (Fig.1) has also been used for insertion of ligands for specific cell targeting due to its position on the viral capsid (Curiel et al, 2002; Glasgow et al, 2005; Zakhartchouk et al, 2004).

1.4 Porcine Adenovirus

Porcine adenoviruses (PAdV), members of *Mastadenovirus* genus were first isolated from a rectal swab of a piglet with diarrhea (Haig et al. 1964). PAdV's have since been isolated from several sources including encephalitic piglet brains, healthy pig feces, and piglet kidney cell cultures (Kadoi et al., 1995; Kadoi et al., 1997; Maluquer de Motes et al., 2004). In addition, PAdV's have been found in tonsil, lymph nodes, spleen and lungs of pigs with toxoplasmosis as well as nasal secretions of piglets with respiratory illness (Derbyshire et al, 1966; Hirahara et al.,1990).

1.4.1 Classification

So far, five serotypes of PAdVs have been identified in pigs, which are divided into three groups: group A (PAdV-1 to 3) group B (PAdV-4) and group C (PAdV-5) (van der Avoort, 1989) based primarily on hexon antigenic determinants as well as fiber

similarities or differences. Determination of serotypes is evident from cross neutralization, physicochemical properties such as susceptibility of nucleic acid to chloroform or ether, sensitivity to sodium deoxycholate, trypsin, acid stability and heat stability, morphology under the scanning electron microscope and most notable restriction enzyme digest patterns (Clarke et al, 1967; Hirahara et al, 1990; Nagy and Tuboly, 2000; Nagy et al., 2001; Nagy et al., 2002).

1.4.2 Porcine Adenovirus serotype 3

Of the five known serotypes, PAdV-3 is the best characterized. PAdV-3 (prototype strain 6618) replicates to the highest titers in cell culture and causes subclinical infections and transient diarrhea in young pigs (Hirahara et al, 1990). Our laboratory has determined the DNA sequence and transcriptional map of the entire genome of PAdV-3 (Reddy et al, 1998). The overall organization of the PAdV-3 genome is similar to HAdV's with minor differences (Fig. 3) including the presence of a single small virion associated RNA gene, the absence of additional leader sequences (x,y,and z) in the fiber, six late region genes (L1 to L6), a relatively high G + C content (63.7%), smaller and more simple E3 region, no RGD motif in the penton base and the lack of a consensus protease cleavage site in both pVII and IIIa (Reddy et al, 1998). The PAdV-3 fiber is shorter (448 residues with 15 shaft repeats) compared to the HAdV-2 or -5 counterparts (Reddy et al, 1995,1998).

The early (E1) region of PAdV-3, located between map units 1.5 to 9.9, codes for E1A and E1B (E1B^{small} and E1B^{large}) proteins (Reddy et al., 1998). The E1A region is located between map units 1.5 to 3.8 and produces four types of transcripts from a primary E1A transcript. The E1B region is located between map units 4.0 to 9.9 and produces two transcripts from a primary transcript. Sera against E1A, E1B^{small} and E1B^{large} detected proteins of 35 kDa, 23 kDa and 53 kDa in PAdV-3 infected cells (Zhou and Tikoo, 2001). Analysis of mutant viruses suggested that while E1A and E1B^{large} are essential for virus application, E1B^{small} is not essential for replication of PAdV-3 (Reddy et al., 1999; Zakhartchouk et al, 2003; Zhou and Tikoo, 2001). Moreover, E1A is required for transactivation of PAdV-3 viral genes (Zhou and Tikoo, 2001). In addition, the E1 transcriptional control region of PAdV-3 overlaps with the cis-acting packaging domain

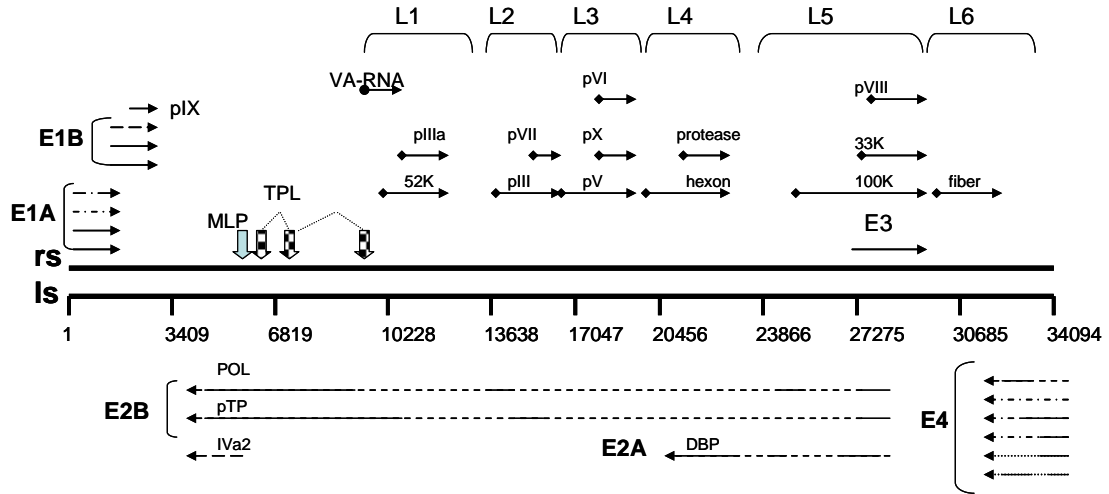


Figure 3. Transcription map and genome organization of PAdV-3 (adapted from Reddy et al. 1998). Central solid lines delineate double stranded 34 Kb DNA showing the top line as the right strand and the bottom line as the left strand. Solid lines indicate sequences present in mature mRNA, broken lines delineate introns and arrowheads indicate poly(A)⁺ sites and show the directionality of transcription.

of PAdV-3 (Xing and Tikoo, 2003, 2004) and contains a bifunctional regulatory element upstream of the E1A TATA box (Xing and Tikoo, 2004) which enhances E1A transcription and represses E1B transcription.

The E2 region of PAdV-3, located from map unit 79.4 to 13, codes for E2A (DBP), E2B (terminal protein [pTP], and polymerase [pol]) proteins (Reddy et al, 1998). The PAdV-3 DBP is 457 amino acids long and contains a highly conserved C-terminal domain and poorly conserved N-terminal domain.

The C-terminal domain is involved in DNA binding, the initiation and elongation phases of DNA replication as well as transcriptional control of the major late promoter (Reddy et al, 1998). PAdV-3 DBP has been subsequently characterized (Zhou et al, 2001) and found to be expressed in both early and late infection stages. The constitutive expression of DBP has helped in developing a method for titration of virus (Zhou et al. 2001) that is comparable to the plaque assays previously used. The pTP of PAdV-3 is 631 amino acids in length and shows 25.7% to 62.9% homology with pTPs of other adenoviruses (Reddy et al., 1998). The sequence motif YSRLRYT, believed to play a role in protein primed initiation of adenovirus DNA replication, is conserved in pTP of PAdV-3. The pol of PAdV-3 is 1177 amino acids in length and shows homology of 31.2% to 47.9% with its counterparts from other adenoviruses. The pol of adenoviruses including PAdV-3 shares five of the six conserved regions with the other members of the alpha family of pols (Reddy et al., 1998).

The E3 region of PAdV-3 located between pVIII and fiber genes is 1179 bp long (Reddy et al., 1998) and shares a poly A signal with the L5 region genes. One of the ORF's encodes a protein that shows homology with a 13.3 KDa E3 protein of canine adenovirus type 2. It also contains a tripartite leader sequence (TPL) at its 5' end. Overall, PAdV-3 E3 has been found to have fewer ORF's and a much simpler organization as compared to HAdV E3 (Reddy et al., 1995; 1998).

The E4 region is located between 92 to 99 map units, which is transcribed from the "1" strand (Reddy et al., 1997). The E4 region of PAdV-3 has the potential to encode seven ORF's (Reddy et al., 1997). Of the seven ORFs, four ORF's show no homology with E4 proteins of other adenoviruses. Deletion mutants for each ORF in E4 revealed that only ORF 3 is essential for viral replication (Li and Tikoo, 2004). As a result,

deletion of 1.975 kb of E4 increases the insertion capacity of replication-competent PAdV-3 (E3+E4 deleted) to 4.3 kb (Li and Tikoo, 2004) and that of replication-defective PAdV-3 (E1+E3+E4 deleted) to 7 kb, which will be helpful for constructing PAdV-3 vectors expressing multiple genes.

Based on the kinetics of expression, two genes coding for pIX and IVa2 proteins are classified as intermediate region genes. The pIX gene is located between 9.9 and 12 map units and produces one transcript, which shares its polyadenylation signal with genes coding for E1B (Reddy et al., 1998). The PAdV-3 pIX is a protein of 199 amino acids in length, the longest pIX of any adenovirus characterized to date. Interestingly, only the amino-terminal portion of the protein showed homology with pIX of other adenoviruses. Moreover, the pIX of the PAdV-3 is unusual in that the central portion of the protein has stretches of glutamine, alanine, glutamate, and proline although the significance of these amino acid stretches is not known (Reddy et al., 1998). The gene encoding IVa2 is expressed as a spliced mRNA species containing two exons and lacking an intron of 257 nucleotides. It shows homologies of 25.1% to 65.3% with the IVa2 genes of other adenoviruses (Reddy et al., 1998). A recent study suggests that IVa2 interacts with pVIII during PAdV-3 infection (Singh et al., 2005).

The late region genes of PAdV-3 are transcribed from the MLP and are organized into six families L1 to L6 (Reddy et al., 1998). The L1 region encodes both 52kDa and IIIa proteins via alternate RNA splicing. The 52K protein of PAdV-3 is 335 amino acids in length and is 80 amino acids shorter than the corresponding protein in HAdV-2. The central portion of PAdV-3 52K protein shows significant homology with the 52K proteins from other adenoviruses. The 52/55K protein is found both early and late in infection while the IIIa protein is only found late in infection (Molin et al., 2002). The IIIa protein of PAdV-3 is 622 amino acids long, the longest thus far reported for any known adenoviruses and shows low homology to IIIa proteins of other adenoviruses (Cuillel et al., 1990; Reddy et al., 1998). The IIIa of PAdV-3 is unusual in that it lacks consensus protease cleavage sequence found in HAdV-5 (Cuillel et al., 1990; Molin et al., 2002; Reddy et al., 1998).

The L2 region of PAdV-3 encodes pIII (penton base) and pVII proteins (Reddy et al., 1998). The penton base protein sequences are highly conserved among different

adenoviruses. The penton base protein of PAdV-3 is much shorter due to deletions near the N- terminus and central portions of the protein as compared to HAdV-2 (Reddy et al. 1998). The HAdV-2 and 5 penton base proteins contain an Asp-Gly- Asp (RGD) motif, which interacts with integrins and facilitates virus penetration. The penton base of PAdV-3 lacks such RGD motifs and likely mediates cell entry via other sequences. The PAdV-3 pVII is 171 amino acids long and shows a high degree of sequence conservation in the amino terminal domain, including the protease cleavage site but is poorly conserved for the remainder of the protein (Reddy et al., 1998). PAdV-3 pVII is also very rich in basic amino acids, which is consistent with the putative function to condense viral DNA (Lee et al., 2003).

The L3 region of PAdV-3 encodes, pV, pVI and pX. The pV protein of PAdV-3 is 629 amino acids in length, the longest pV reported so far with extra amino acids in the central portion of the protein relative to other adenovirus pV proteins (Reddy et al., 1998). In addition, pV contains two bipartite NLS; one at the N-terminus and one at the C-terminus. The pX of PAdV-3 is 72 amino acids in length and shows significant homology with the C-terminus of the pX protein of HAdV-2 (Reddy et al., 1998). The pVI protein of PAdV-3 is 292 amino acids in length with the central portion the least conserved between species (Reddy et al., 1998).

The L4 region of PAdV-3 encodes hexon and endoprotease proteins (Reddy et al., 1998). The hexon of PAdV-3 is 939 amino acids in length and is a highly conserved protein among different adenoviruses. The hexon protein of PAdV-3 shows differences in the regions making up the antigenic loops of hexon but is highly conserved in the regions responsible for stabilizing the hexon structure. The proteinase of PAdV-3 is 204 amino acids in length, which is similar to other adenoviruses, which range from 201 to 214 amino acids.

The L5 region of PAdV-3 encodes two non structural proteins (100K, 33K) and a structural protein (pVIII) (Reddy et al., 1998). The 100K protein of PAdV-3 is 838 amino acids long and shows 28%-52.5% homology to 100K proteins of other adenovirus. The PAdV-3 33K protein is 225 amino acids and shows no homology with the corresponding proteins from other adenoviruses (Kulthrestha and Tikoo, 2004). The pVIII protein of PAdV-3 is 223 amino acids long. The N- and C-terminal regions of

pVIII of PAdV-3 shows significant homology to corresponding regions of pVIII of other adenoviruses. Recently, pVIII has been shown to interact with IVa2 during PAdV-3 infection (Singh et al., 2005).

The L6 region of PAdV-3 encodes the fiber protein. The fiber protein of PAdV-3 is 447 amino acids long and is involved in the initial attachment of virus to the receptors on the cells. The N-terminus of PAdV-3 fiber shows significant homology with N-terminal domains of other adenovirus fiber proteins. The fiber protein of PAdV-3 can be divided into the tail, shaft and knob regions (Reddy et al, 1998). However, PAdV-3 fiber appears to mediate virus attachment to the cells by recognizing receptors different than CAR recognized by HAdV-2 fiber (Bangari and Mittal, 2005).

Interestingly, a recent report suggests that the viral RNAs are directly packaged into the PAdV-3 virions (Xing and Tikoo, 2004). These “ready to go” RNAs are delivered quickly to host cells and may facilitate in the initiation of virus infection. These RNA molecules appear to have a different function than the VA RNA encoded by most adenoviruses including PAdV-3 (Reddy et al., 1998) which wreak havoc with the antiviral actions of interferon and are essential for controlling protein synthesis (Kitajewski et al, 1986). More recently, the packaging domain of PAdV-3 has been characterized and found to be located at the left end of the genome. The consensus motifs identified for PAdV-3 packaging do not coincide with those found for HAdV-5 (Xing and Tikoo, 2003). The cis-acting packaging motifs appear to be functionally redundant but not equivalent and contain AT/GC rich sequences. Interestingly, when the sequences responsible for PAdV-3 packaging were moved from the left side of the genome to the right side, viable mutant virus was packaged albeit less efficiently than wild type PAdV-3. This suggests that the packaging domain position and orientation for PAdV-3 is flexible (Xing and Tikoo, 2004).

1.4.3 Porcine Adenovirus as a vector

Human adenovirus vectors have demonstrated great potential as a gene delivery system for applications such as recombinant vaccines and cancer therapy. However, use of human adenoviruses as a vaccine delivery system in domestic animals is limited. Since non-human adenoviruses are species specific, attempts are being made to develop animal

specific adenoviruses as a vaccine delivery vehicle. As such, PAdV-3 has been the logical choice for developing a vaccine delivery vehicle for pigs. Moreover, therapeutic use of HAdV-5 vectors in humans is limited by pre-existing immunity to human adenoviruses (HAdVs), resulting in low transduction efficiency of the virus in therapy (Hemmi et al, 1998; Russel, 2000; Amalfitano and Parks, 2002). Also, vector specific immune responses occur upon administration of all adenoviral vector types (Romano et al., 2000; Rots et al., 2003; Roy et al., 2005). This may affect the efficiency of vector transduction during readministration of the adenovirus, which is often required to maintain therapeutic levels of transgene expression. Some of these problems may be overcome by use of non-human adenoviruses including PAdV.

1.4.3.1 Porcine adenovirus-3 as a vector

Availability of the complete DNA sequence and transcriptional map of the PAdV-3 genome has helped to develop a rational and efficient method of constructing recombinant PAdV-3 (Reddy et al., 1998) using homologous recombination machinery of *E. coli* (Chartier et al., 1996). Earlier, the construction and use of partially deleted E3 or E1A for insertion of foreign genes has been reported (Reddy et al., 1999a,b). Recently, characterization of E1 and E4 has led to the construction of mutant PAdV-3s containing deletions in E1 (Zakhartchouk et al., 2003), E3 (Reddy et al., 1999b) and/or E4 (Li and Tikoo, 2004) regions, which has increased the insertion capacity of PAdV-3 vector to 4.3 kb (replication competent) and 7.3 kb (replication defective). Moreover, construction of recombinant PAdV-3 containing foreign genes inserted between the E4 region and the right ITR has also been reported (Reddy et al., 1999; Hammond and Johnson, 2005). The construction of recombinant PAdV-3 expressing vaccine antigens (Reddy et al., 1999b), cytokines (Hammond and Johnson, 2005) and reporter genes (Reddy et al., 1999a,b; Zhou and Tikoo, 2001; Zakhartchouk et al., 2003) have been reported. Thus, the feasibility of engineering PAdV-3 for the purpose of using it as a vaccine delivery vehicle has been demonstrated.

So far replication-competent PAdV-3 expressing vaccine antigens have been evaluated in protection/challenge experiments in pigs. Vaccination of outbred swine populations with a single dose of recombinant rPAV-gp55 (containing gp55 of classical

swine fever virus [CSFV] inserted in the region between E4 and right ITR) subcutaneously resulted in complete protection from subcutaneous lethal challenge with CSFV (Hammond et al., 2001). However, pigs immunized with a single dose of rPAV-gp55, either subcutaneously or orally were only partially protected to oral challenge with CSFV (Hammond et al., 2001). A subsequent study suggested that pigs immunized subcutaneously with a single dose of recombinant rPAV-gp55 and challenged by exposure to other infected animals were protected from disease whereas pigs immunized orally with one dose of rPAV-gp55 did not survive the challenge by “in contact” exposure (Hammond et al., 2003). Vaccination of pigs with two doses of recombinant rPAdV-gD (containing gD gene of pseudorabies virus inserted in E3 region) subcutaneously provided partial protection from intranasal challenge with pseudorabies virus (Hammond et al., 2001). Moreover, vaccination of pigs with a single dose of recombinant rPAdV-G-CSF (expressing porcine granulocyte colony stimulating factor) or rPAdV-IFN- γ (expressing porcine interferon gamma) resulted in significant weight gains and inhibition of *Actinobacillus pleuroneumoniae* infection, respectively, in pigs (Hammond and Johnson, 2005).

PAdV-3 has also been recently shown to efficiently infect both human and murine cells in culture (Bangari and Mittal, 2004). This facilitates the use of a mouse model to test new recombinant PAdV-3 as compared to HAdV-5 as well as suggest the utility of using PAdV-3 vectors for human gene therapy and vaccination. It has been observed that human 293 and SAOS-2 osteosarcoma cells were efficiently transduced by a recombinant PAdV-3 carrying a green fluorescent protein (GFP) cassette in place of E1 (Zakhartchouk et al., 2003). In addition, PAdV-3 was found to transduce MCF 10A (mammary epithelium), MCA-MB-231 (malignant breast cancer cell), PC-3 (prostate cancer), and Jurkat (T-cell leukemia) cells (Bangari et al, 2005). This suggests that PAdV-3 is less promiscuous than HAdV-2 or 5 and may be useful in specific targeting of some human cancers (Zakhartchouk et al., 2003; Bangari et al., 2005).

1.4.3.2 Porcine adenovirus-5 as a vector

PAdV-5 was isolated in Japan (Hirahara et al., 1990) and is non-pathogenic. The determination of the complete nucleotide sequence (Nagy et al., 2001)

has helped to create replication-competent PAdV-5 containing a partial deletion of E3 region deemed non essential for virus replication (Tuboly and Nagy, 2000). Recombinant PAdV-5 vector containing different forms of S gene of transmissible gastroenteritis virus (TGEV) inserted in the E3 region have been constructed (Tuboly and Nagy, 2001). Oral immunization of pigs with recombinant PAdV-5 expressing TGEV S glycoprotein induced TGEV specific systemic and mucosal immune responses (Tuboly and Nagy, 2001).

2.0 INTRODUCTION

Human Adenoviral (HAdV) vectors have been studied for their potential use in vaccine delivery and gene therapies. However, the use of HAdV as a gene therapy and vaccine vector has a number of limitations. Firstly, humans contain pre-existing antibodies against HAdVs due to prior exposure to HAdV. Secondly, reversion of mutant viruses to wild-type is a possibility as ubiquitous HAdV existence in nature can result in spontaneous recombinations and recovery of lost functions. Thirdly, the wide range of cells transduced by HAdV-5 based vectors makes it difficult to target the vector to a particular organ or population of cells within the body.

The use of species-specific animal adenoviruses like PAdV-3 may be a promising alternative to HAdV-based regimes. PAdV-3 does not replicate in humans cells (Reddy et al., 1999) and there is no pre-existing immunity to overcome (Bangari and Mittal, 2004). However, PAdV-3 only transduces a narrow range of human cells *in vitro* (Zakhartchouk et al, 2004; Bangari et al, 2005). Apart from eluding pre-existing immune responses, PAdV-3 vectors should be able to transduce specific cells efficiently. One way to achieve this is by genetic modification of capsid proteins (Wu and Tikoo, 2004; Zakhartchouk et al., 2004) including IIIa.

However, in order to use PAdV-3 IIIa for expressing specific targeting ligands, it is important to know the structure and function of PAdV-3 IIIa in virus replication and capsid assembly.

3.0 RESEARCH OBJECTIVES AND HYPOTHESIS

Our working hypothesis states that the molecular characterization of the IIIa protein of PAdV-3 will:

- A) lead to better understanding of capsid formation during virus maturation,
- B) determine the role of protein IIIa during PAdV-3 viral infection
- C) identify a putative location for foreign ligand insertion capable of altering native PAdV-3 tropism.

4.0 MATERIALS AND METHODS

4.1 Cell lines and Viruses

Swine Testicle (ST) cells were cultured in Eagle's minimum essential medium (MEM) supplemented with 10% fetal bovine serum (FBS). COS-7 cells were cultured in Dulbecco's modified Eagle's minimum essential medium (DMEM) supplemented with 10% FBS. All cell lines were grown at 37°C, 5%CO₂ atmosphere.

Wild-type PAdV-3 (strain 6618) was grown in ST cells supplemented with 5% FBS and purified using discontinuous cesium chloride density gradient centrifugation. Briefly, 20 x T150 cm² flasks of ST cells were infected at an MOI of 0.1. After 48 h post infection (p.i.), the cells were harvested and subjected to 6 rounds of freeze-thaw. The cellular debris was removed by centrifugation and the supernatant was loaded onto CsCl gradients (1.3 to 1.2 g/cm³ final gradient). The gradients were centrifuged at 35,000 rpm (SW40Ti Beckman rotor) for 24 h and viral bands harvested. Purified virus was dialyzed against 10mM Tris buffer and stored in 10% glycerol, 10mM Tris buffer at -80°C until use.

4.2 Antibody production

Specific antisera were generated to hydrophilic regions of PAdV-3 proteins by either a GST-fusion/expression system or by synthesis of unique peptides. Table 4 gives an overview of PAdV-3 antiserum used and methods of production.

Two approaches were used to produce IIIa specific antibodies; a) GST-fusion protein, and b) IIIa-specific peptides.

4.2.1 GST-Protein fusion

Based on the antigenic index of PAdV-3 IIIa, a 408 bp fragment containing N-terminal amino acids 22 to 158 of IIIa was amplified by PCR using primers (5'): CGG GAT CCG GGC GAC GCG GAT G and (3'): GGA ATT CAC GAG GCG ATG AAG GCA T and pFPAV200 (containing the full length PAdV-3 viral DNA genome) plasmid DNA (Reddy et al, 1998) as a template. The 408 bp DNA fragment was digested with *Bam*HI - *Eco*RI, and ligated to *Bam*HI - *Eco*RI digested plasmid pGEX-5X-1 (Pharmacia) creating plasmid IIIa1. Similarly, a 390 bp DNA fragment (containing amino acid 480-610 of IIIa) amplified by PCR [using primers (5'- CGG GAT CCT GGC CTC TCT GGG AAA GC and 3'-GGA ATT CAC TCG GGC GCT TCG AAG CG and plasmid pPAV200 DNA as a template] was digested with *Bam*HI - *Eco*RI and ligated to *Bam*HI - *Eco*RI digested plasmid pGEX-5X-1 creating plasmid IIIa2. The identity of recombinant plasmids was confirmed by restriction enzyme analysis and DNA sequencing. The plasmid DNA was individually transformed into the BL21 strain of *Escherichia coli* and GST-fusion proteins were induced using isopropyl- β -thiogalactoside (IPTG) at a final concentration of 0.1 mM. Cultures were concentrated and sonicated in 0.1M phosphate buffered saline (PBS) on ice to release the fusion protein from the bacteria. The sonicate was exposed to a GST resin on Glutathione Sepharose 4B column (Pharmacia) and the fusion proteins were bound, washed and finally eluted in the presence of reduced glutathione (Sigma). The eluted proteins were separated on 10% sodium dodecyl-sulfate (SDS) polyacrylamide gel electrophoresis (PAGE) and stained with Coomassie blue G-250 stain to visualize fusion protein solubility and stability.

4.2.2 IIIa peptides

Two peptides of 14 amino acids (amino acid 541-554) and 23 amino acids (592 to 614) were synthesized on the Pioneer Peptide Synthesis system (Perkin Elmer) and conjugated to keyhole limpet hemocyanin (KLH) as a carrier molecule (with kind thanks to Dr. Samuel Attah-Poku at VIDO).

4.2.3 Immunizations

Before immunization, serum was collected from sixteen week old naive rabbits for use as a control. Following prebleeds, the rabbits were immunized each time, at four sites intra-dermally, with the GST-fusion protein (500 µg/rabbit) or conjugated peptide (500µg/rabbit) emulsified with Freund's Complete Adjuvant (FCA) followed by two injections (GST-fusion protein, 250 µg/rabbit or conjugated peptide, 250 µg/rabbit), as above, except in Freund's incomplete adjuvant (FIA), four weeks apart for a total of three injections per rabbit. Serum was collected twelve days after the third injection to test for IIIa specific antibodies.

4.3 Radio- immunoprecipitation

Monolayers of ST cells (1×10^5 per well) in 6 well tissue culture dishes were infected with wild type PAdV-3 at an MOI of 1. After 24 h of initial incubation, the cells were starved for 4 h in MEM without methionine/cysteine (JRH Biosciences), before addition of 100 µCi per well of [35 S]-labeled methionine/cysteine translabel (Perkin Elmer). After 24 h of labeling, the cells were harvested, lysed in RIPA buffer (0.15M NaCl, 50mM Tris-HCl pH8.0, 1% NP-40, 1% deoxycholate, containing 1mM PMSF and 0.1% SDS) and mildly sonicated. The cell debris was removed by centrifugation. The supernatant was collected, mixed with rabbit anti-IIIa serum at 1:100 dilution (500 µl volume) and incubated for 4 h at room temperature. Finally, protein A sepharose beads (Pharmacia) were added to the antibody plus [35 S]-labeled infected cell lysate mixture, and the complexes were further incubated for 24 h at 4⁰C. The bound complexes were washed 3 times with RIPA buffer, diluted in SDS-sample loading buffer (100mM Tris/HCl pH 6.8, 2% β mercaptoethanol [β-ME], 4%SDS, 0.2% bromophenol blue, 10% glycerol). The samples were boiled for 5 min and the proteins were separated on a 10% SDS-PAGE under reducing conditions. The gel was fixed, dried and then exposed to X-ray film for 3 days at -70 ⁰C and subsequently developed.

4.4 Western blot analysis

Monolayers of ST cells (1×10^5 per well) in 6 well tissue culture dishes were infected with wild type PAdV-3 at an MOI of 1. PAdV-3 infected ST cells were scraped and washed with 0.1M PBS pH 7.5. Cells were lysed with RIPA buffer and sonicated. Proteins from lysates of cesium chloride (CsCl) gradient purified wild-type PAdV-3 or infected ST cells were separated on 10% SDS-PAGE under reducing conditions, transferred to 0.45 μ m nitrocellulose membrane and blocked in 0.1M tris-buffered saline pH 8.0 (TBS) containing 3% skim milk. Membranes were cut into strips and incubated separately with different anti-IIIa sera, negative control sera (pre-bleed, anti -BAdV-3) or positive control sera (anti PAdV-3) diluted in 0.1M TBS pH 8.0 with 0.1% tween 20 (TBST) containing 0.1% BSA, 2 h at room temperature. After washing three times, the membranes were incubated with alkaline phosphatase conjugated goat anti-rabbit IgG (H+L) (Jackson ImmnoResearch labs) secondary antibody diluted $1:10^5$ in TBST containing 0.1% BSA for 2 h at room temperature. The membrane strips were washed three times with TBST containing 0.1% BSA and once with TBS without Tween 20 before developing using BCIP/NBT chromagenic substrate (Sigma) according to manufacturer's directions.

4.5 Immunostaining

Monolayers of ST cells grown in 4-well permanox-coated chamber slides (Lab Tek) in MEM, supplemented with 10% FBS were infected with wild-type PAdV-3 at an MOI of 10. Following a 2 h incubation, the medium was replaced with MEM containing 5% FBS. At 24 h post infection, the cells were fixed and permeabilized in methanol/acetone 1:1 at -20°C for 20 min. The cells were washed with 0.1M PBS pH 7.5 and incubated with normal goat serum for 1 h at room temperature. Subsequently, the cells were incubated with anti-IIIa serum diluted in 0.1M PBS pH 7.5, 1% goat serum for 2 h at room temperature followed by an additional 2 h incubation with the secondary Cy2[®] conjugated goat anti rabbit IgG (H+L) (Jackson Immunoresearch) in 0.1M PBS pH 7.5, with 1% goat serum. The monolayers were washed, dried in the dark and mounted with Citifluor anti-quench glycerol-based medium (Citifluor). Finally, the cells were viewed under UV microscope using the Zeiss Axiovision viewer software.

4.6 Immunogold Staining

Coated nickel grids were floated on the surface of 20 µl of CsCl purified wild-type PAdV-3 for 2 min with no stirring followed by then brief washing with water. The grids were dried following initial adsorption of virus and subsequently blocked with a 20 µl of blocking buffer (0.1M PBS pH 7.5, 1%BSA and 0.1% Tween20) for 15 min. The grids were incubated with a 20 µl drop of anti-IIIa serum diluted in blocking buffer for 1 h at room temperature. The grids were washed through a series of drops of PBS and excess buffer was blotted off. The grids were then incubated with 20 µl of gold conjugated secondary anti-rabbit antibody (British Biocell EM GAR 10 nm) in blocking buffer for 1 h at room temperature. After washing the grids with PBS and water, excess water was blotted off and grids were negatively stained with 0.5% phosphotungstic acid (PTA) pH 6.0 for 2 min and finally washed with water. The dried grids were visualized under a PHilys 410LS electron microscope (EM).

4.7 Construction of IIIa deletion plasmids

The plasmid vectors were constructed using restriction enzymes and DNA modifying enzymes as per manufacturer's instructions. PCR template DNA in all reactions was pPAV200 (Reddy, et al., 1998)

4.7.1 Construction of plasmid IIIa

A 1.86 kb DNA fragment (encoding IIIa protein) was amplified by PCR using primers A1 and B4 (Table 2) and plasmid pPAV200 DNA as a template. The amplicon containing the full length IIIa ORF was digested with *Bam*HI - *Eco*RI and ligated to *Bam*HI - *Eco*RI digested pCDNA3 (Invitrogen) creating plasmid IIIa. Positive clones were confirmed with restriction digest analysis.

4.7.2 Construction of plasmid IIIaD1

A 1.4 kb DNA fragment, amplified by PCR using primers A2 and B4 (table 2) and pPAV200 as DNA template, was digested with *Bam*HI - *Eco*RI and ligated to *Bam*HI

- *EcoRI* digested pCDNA3 (Invitrogen) creating plasmid IIIaD1. Positive clones were confirmed with restriction digest analysis.

4.7.3 Construction of plasmid IIIaD2

A 415 bp DNA fragment was amplified by PCR using primers A1 and B1 (Table 2) and pPAV200 as template. A 1.0Kb DNA fragment was amplified by PCR using primers A3 and B4 (Table 2) and pPAV200 as a DNA template. In a third PCR reaction, both amplified fragments were annealed and external primers A1 and B4 (Table 2) were used to PCR across the fragments to give a final 1.4 kb amplicon deleted for bases 475-816 (Fig. 4). This PCR product was digested with *BamHI* and *EcoRI* and ligated to *BamHI* and *EcoRI* digested pCDNA3 (Invitrogen) (Lee et al., 2004). Positive clones were confirmed with restriction digest analysis.

4.7.4 Construction of plasmid IIIaD3

A 816 bp DNA fragment was amplified by PCR using primers A1 and B2 (table 2) and pPAV200 (Reddy et al, 1998) as template. A 647 bp DNA fragment was amplified by PCR using primers A4 and B4 (Table 2) and pPAV200 (Reddy et al, 1998) as DNA template. In a third PCR reaction, the fragments that had 18 bp of internal overlap, were annealed and external primers A1 and B4 (table 2) were used to PCR across to give a final 1.4 kb amplicon deleted for bases 817-1231 (Fig. 4). This PCR product was digested with *BamHI* and *EcoRI* and ligated to *BamHI* and *EcoRI* digested pCDNA3 (Invitrogen) (Lee et al., 2004). Positive clones were confirmed with restriction digest analysis.

4.7.5 Construction of plasmid IIIaD4

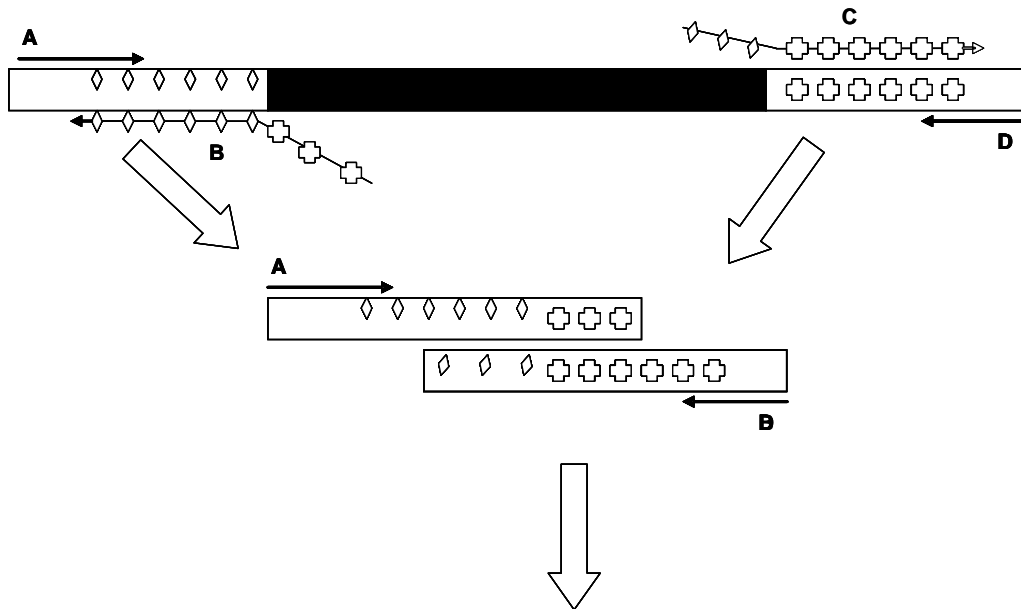
Primers A1 and B3 (Table 2) were used to amplify 1.4 Kb of IIIa deleted for bases 1231 to 1869 using pPAV200 (Reddy et al, 1998) as a DNA template. The 1.4 kb amplicon was digested with *BamHI* and *EcoRI* and ligated to *BamHI* and *EcoRI* digested pCDNA3. Positive clones were confirmed with restriction digest analysis.

Table 2: List of PAdV-3 deletion primers

A1	5'-CGGATCCCATGGCGGCGAGCTCTGAA-3'
B1 (del2)	3'-TTGGACCCGTC GGACCGGCCTGCGACCG -5'
A3 (del2)	5'-GCCTGGCC GGACGCTGGCCA ACTTGCATGT-3'
A4 (del3)	3'-CCCTTCAGTATGT GCGGCCAAGAGCGCCA -5'
B2 (del3)	5'-CACGCCGGT TCTCGCGGT AGAGTGT CAGC -3'
B4	5'-CCGGAATTCCTTACAGCCCCTTGGGGGCGATG-3'

Overlapping regions to create deletions are shown in bold

Step 1: primary pcr



Step 2: ligation pcr



Fig. 4. Overlap extension pcr for deletion mutagenesis. Two pcr products representing the flanking regions of the sequence to be deleted are prepared by using one nonchimeric and one chimeric primer. In the second step, two pcr products are used as the template for a ligation pcr using the outermost primer pair. (Adapted from Lee et al, 2004)

4.7.6 Construction of plasmid IIIa NLS

Primers A3 and B3 (Table 2) were used to amplify the region containing the putative IIIa NLS using pPAV200 as a DNA template. The 415 bp amplicon was digested with *Bam*HI and *Eco*RI and ligated to *Bam*HI and *Eco*RI digested plasmid pEYFP-N1(Clontech, BD Biosciences). Positive clones were confirmed with restriction digest analysis.

4.8 Transfection of plasmids encoding IIIa deletions and nuclear localization analysis

COS-7 cells were grown, in Dulbecco's modified Eagle's essential medium (DMEM) supplemented with 10% FBS, to 80% confluency in one well of two well permanox-coated tissue culture chamber slides (Lab Tek). The individual plasmid DNAs (3µg per well) were transfected into COS-7 cells (growing in Opti-MEM serum free medium; Invitrogen/GIBCO) using Lipofectin (Invitrogen) transfection reagent according to manufacturer's instructions. After incubating for 6 h at 37°C, the medium was replaced with DMEM containing 10% FBS. After 48 h of incubation at 37°C in 5% CO₂, the cells were stained as described in section 4.5 using anti-IIIa serum.

4.9 Yeast 2 Hybrid screening for viral protein: protein interactions

To examine the role of IIIa interactions with other structural/regulatory viral proteins during infection, the Matchmaker GAL4 two-hybrid system 3 (BD Biosciences, Clontech) was used to determine protein: protein interactions.

4.9.1 Construction of IIIa-BD

IIIa was amplified as described in section 4.7, and ligated to *Bam*HI – *Eco*RI digested plasmid pGBK-T7 (BD Biosciences) creating plasmid IIIa-BD. This creates a fusion of IIIa to the GAL4 DNA binding domain in the GAL4-BD vector (Fig. 5).

4.9.2. Construction of pGAD-AD vectors

Using pPAV200 (Reddy et al, 1998) as a DNA template, PAdV-3 genes IVa2, protease, 33K, 100K, IIIa, pVI, pVII, pVIII, pIX, pX, and 52K were amplified as

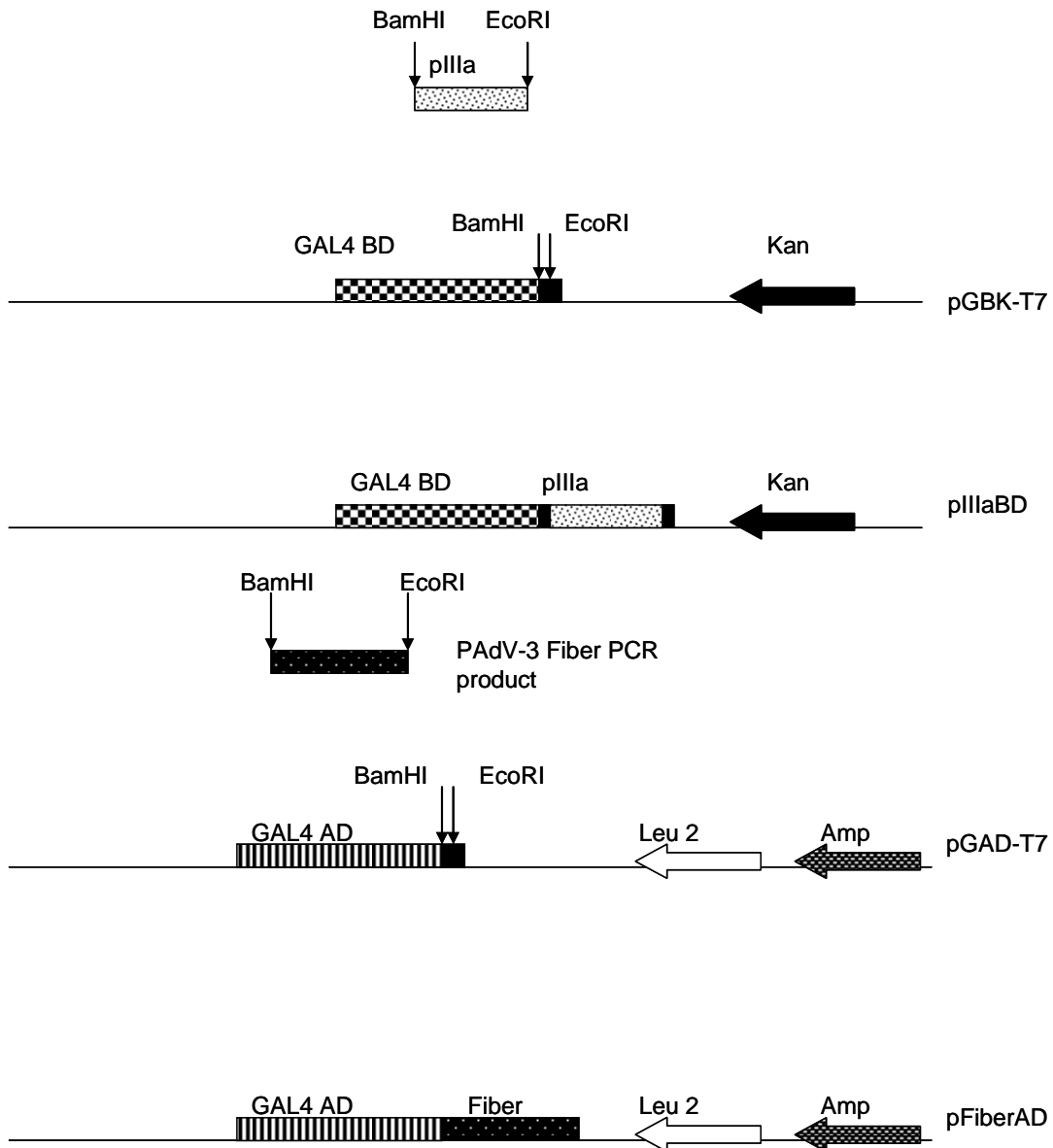


Figure 5. Construction of yeast two hybrid vectors. The sequence encoding IIIa with flanking *Bam*HI and *Eco*RI restriction sites was amplified by PCR and cloned 3' to the GAL4 BD in pGBK-T7 plasmid MCS. Likewise, PAdV-3 fiber gene was amplified by PCR with flanking *Bam*HI and *Eco*RI restriction sites and cloned 3' to the GAL4 AD in pGAD-T7 plasmid MCS.

described previously (Singh et al, 2004). In addition, the fiber, penton base, and hexon genes were amplified using primers (Table 3) and pPAV200 (Reddy et al, 1998) as a DNA template (Fig. 5).

Using primers DMS-Fiber-F and DMS-Fiber-R (Table 3), and plasmid pPAV200 (Reddy et al, 1998) as a template DNA, the 1.4 kb DNA fragment encoding the fiber gene was amplified by PCR and digested with *Bam*HI – *Eco*RI. The fragment was ligated to *Bam*HI -*Eco*RI digested pGAD-T7 (BD Biosciences) creating plasmid pFiber-AD. The 1.4 kb DNA fragment (encoding penton base) was amplified by PCR ,using primers DMS-pIII-F and DMS-pIII-R (Table 3) and plasmid pPAV200 (Reddy et al, 1998) as a template. The fragment was then digested with *Bam*HI-*Eco*RI and ligated to *Bam*HI - *Eco*RI digested plasmid pGAD-T7 (BD Biosciences) creating plasmid pPENT-AD. Finally, the 2.8 kb DNA fragment encoding hexon was amplified by PCR using primers DMS-Hex-F and DMS-Hex-R (Table 3) and plasmid pPAV200 DNA as template. The resulting fragment was digested with *Xho*I - *Bam*HI and ligated to *Xho*I - *Bam*HI digested pGAD-T7 (BD Biosciences) creating plasmid pHEX-AD. The identity of the recombinant plasmids was confirmed by restriction enzyme analysis of plasmid DNA.

4.9.3 Yeast two hybrid assay

Saccharomyces cerevisiae yeast strain Y187 containing a lacZ reporter gene was transformed with pGBKIIIa-BD DNA using lithium acetate as described in the manufacturer’s protocol. *Saccharomyces cerevisiae* yeast strain AH109 containing HIS3, ADE2 and lacZ reporter genes was then individually transformed with the pGAD-AD PAdV-3 vectors using lithium acetate as described in the manufacturer’s protocol (Matchmaker GAL4 two-hybrid system 3; BD Biosciences, Clontech, Palo Alto, CA). Y187 transformants were selected on medium lacking tryptophan and AH109 transformants were selected on medium lacking leucine. Yeast mating was performed to introduce both plasmids into one yeast cell as per manufacturer’s protocol. Briefly, one colony from pGBKIIIa (Y187) plate was added to 1ml YPD broth and vortexed. An additional colony from each of the pGAD-AD PAdV-3 library plates was added to the YPD broth and vortexed to mix the yeast cells together. The mixture was grown

Table 3. List of yeast two hybrid primers

Gene	Primer sequence
Fiber	DMS-Fib-F:CCG GAATTC ATGGGACCGAAGAAGCAGAAG
	DMS-Fib-R:CGC GGATCCT CATTGCTGGAGTAGTTG
Penton	DMS-pIII-F:CCG GAATTC ATGAGGAGGATGATGCCAGCA
	DMS-pIII-R:CGC GGATCCT TAGAAGGTTCGGCTGCTGAG
Hexon	DMS-Hex-F:CGC GGATCC ATATGGCGACGCCGTCGATGATG
	DMS-Hex-R:CCG CTCGAGTT AGGTGGTGGCGTTCCCGGC

Restriction enzyme sites *Bam*HI, *Eco*RI and *Xho*I are shown in bold.

overnight at 30⁰C. A 100µl of the mixture was plated onto the medium lacking both tryptophan and leucine to select for diploid yeast cells. Diploids were then replica-plated to medium stringency medium lacking tryptophan, leucine and histidine to allow selection of positive interactors. Positive interactors were then further tested on the highest stringency X-α-gal medium lacking tryptophan, leucine, histidine and adenine. Positive interactions exhibit blue color as well as visible yeast colony growth (Geitz, et al 1992).

4.10 Co-Immunoprecipitation

In order to examine the IIIa interactions with other viral proteins, a co-immunoprecipitation was performed as described previously in section 4.3 with the exception of radioisotope labeling of proteins. The complexes were then Western blotted as described in section 4.4. Table 4 gives an overview of antibodies used in interaction studies.

4.11 Transactivation Assays

4.11.1 Construction of pGL-MLP and pGL-E1A

PAdV-3 IIIa protein was tested for potential activation of the PAdV-3 major late promoter and E1A promoter using the pGL3 luciferase reporter system (Promega). The 3Kb MLP and tripartite leader (TPL) cassette was digested from pMLP P3 (data not published) with *EcoRI*, blunted, and then digested with *BamHI* and ligated with the pGL3 Basic Vector (Promega) digested with *BglIII* and *SmaI* to create pGL-MLP as shown in Fig. 6. A 390 bp DNA fragment (containing E1A promoter) amplified by PCR using plasmid pPAV200XhoIRL DNA as a template was digested with *BglIII* - *KpnI* and ligated to *BglIII* and *KpnI* digested pGL3-Basic Vector creating plasmid pGL-E1A. (Fig. 6) Construction of plasmids containing full length and deleted forms of IIIa is described in section 4.7.

Table 4. List of PAdV-3 antiserum tested in co-immunoprecipitation assay.

Name of proteins	method of synthesis	Western blot and Co-IP dilutions used
fiber	GST fusion	1:100
fiber	peptide	1:100
hexon	GST fusion	1:100
hexon	GST fusion	1:100
pIX	peptide	1:100
pIX	peptide	1:100
52K	GST fusion	1:100
IIIa	GST fusion	1:100
E3 13.7kDa	GST fusion	1:100
E1A	GST fusion	1:100
E1Bsmall	GST fusion	1:100
E1Blarge	GST fusion	1:100
DBP	GST fusion	1:100
E4 orf 2	GST fusion	1:100
E4 orf 3	GST fusion	1:100
E4 orf 4	GST fusion	1:100
E4 orf 7	GST fusion	1:100
IVa2	GST fusion	1:100

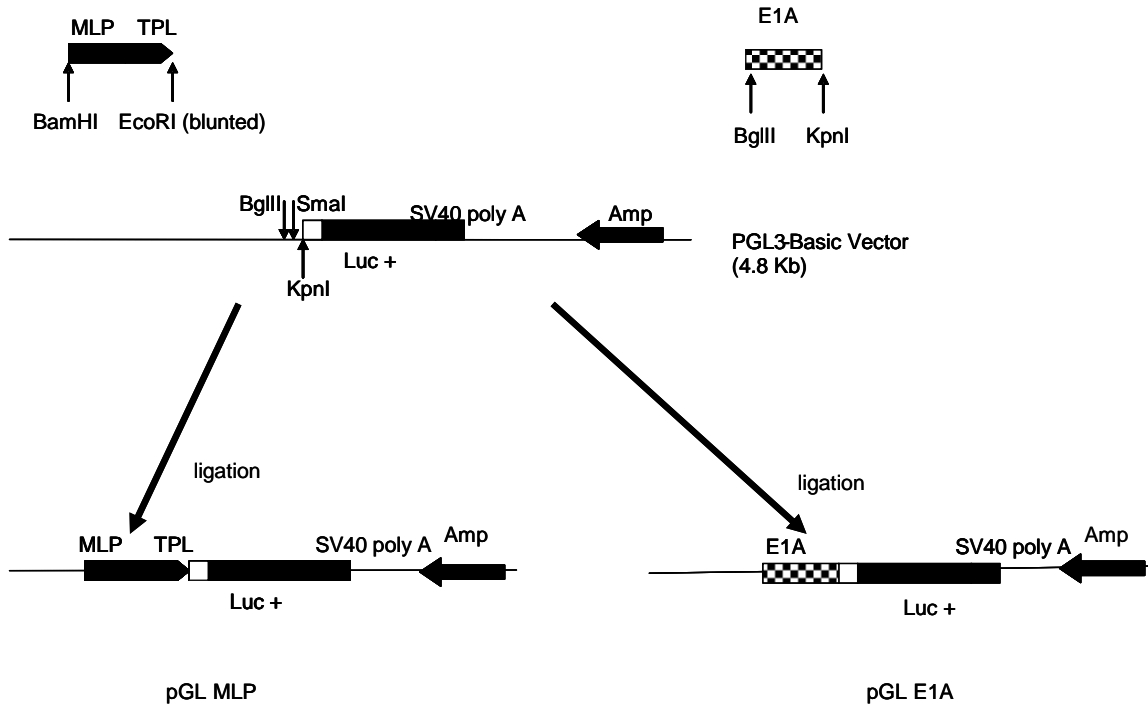


Figure 6. Transactivational plasmid construction. The 3.0 Kb fragment comprised of the MLP and TPL were digested out of pMLP P3 and ligated 5' to the luciferase cassette creating pGL-MLP. Likewise, E1A was amplified by PCR, digested and ligated 5' to the luciferase cassette creating pGL-E1A.

4.12 Construction of recombinant PAdV-3 containing chimeric IIIa

4.12.1. Construction of plasmids

4.12.1.1 Construction of pPC2BsiWI.

A 9.6 Kb FseI fragment was digested out of pFPAV200 (Reddy et al. 1999), blunted with large fragment DNA polymerase (Klenow) and ligated into pCDNA3 (Invitrogen) EcoRV site to generate pPAVPC2 (late region transfer vector of 15 Kb). A unique BsiWI site was inserted upstream of the ATG for IIIa by subcloning a 3.5Kb AgeI fragment of pFPAV200 into Litmus 28i vector (New England Biolabs) digested with AgeI to create pLit28IIIa plasmid. Using pPAVPC2 DNA as template, PCR primers (forward): (GGGACCGCGGCGCTGGAGGTGGCAGTCCCCGCTGACTGCGAGC GATGAGGGTGATG**CGTACG****GATGGCA**ACCAT)

and (reverse): (GGAAGTCA TA CAC GCCGGTGAAGAAG) were designed corresponding to internal SacII sites. Mutation of base 4670 (t-c) and base 4675 (t-g) shown in bold, of pPC2 transfer vector created a unique BsiWI site site 42 bp bases upstream from the starting methionine for the IIIa open reading frame (ORF). The 1.2 Kb PCR product containing the unique BsiWI site was digested with SacII and ligated into shuttle vector, pLit28IIIa correspondingly digested with SacII. Positives clones were identified via restriction digest for the presence of the unique BsiWI site. The shuttle vector pLit28IIIa-BsiWI was then digested with AgeI and the 3.5 kb fragment was ligated back into pPAVPC2 digested with AgeI to create pPAVPC2-BsiWI containing a unique BsiWI site in the late region transfer vector. (Fig. 7)

4.12.1.2. Construction of pPC2EYFP

To generate a EYFP (Enhanced yellow fluorescent protein) IIIa fusion protein, the EYFP gene was amplified by PCR from the plasmid pEYFP-C1 (BD Biosciences) using primers fwd: CGTACGGGTCGCCACCATGGTGAGCAAG and rev: CGTACGACTTGTACAGCTCGTCCATGCCGAGAGTG removing the stop codon and adding BsiWI restriction sites on the 5' and 3' ends of the gene. The amplified EYFP PCR product was digested with BsiWI and cloned in frame into pPAVPC2 digested with BsiWI. Positive IIIa fusion constructs were screened with restriction enzymes and finally

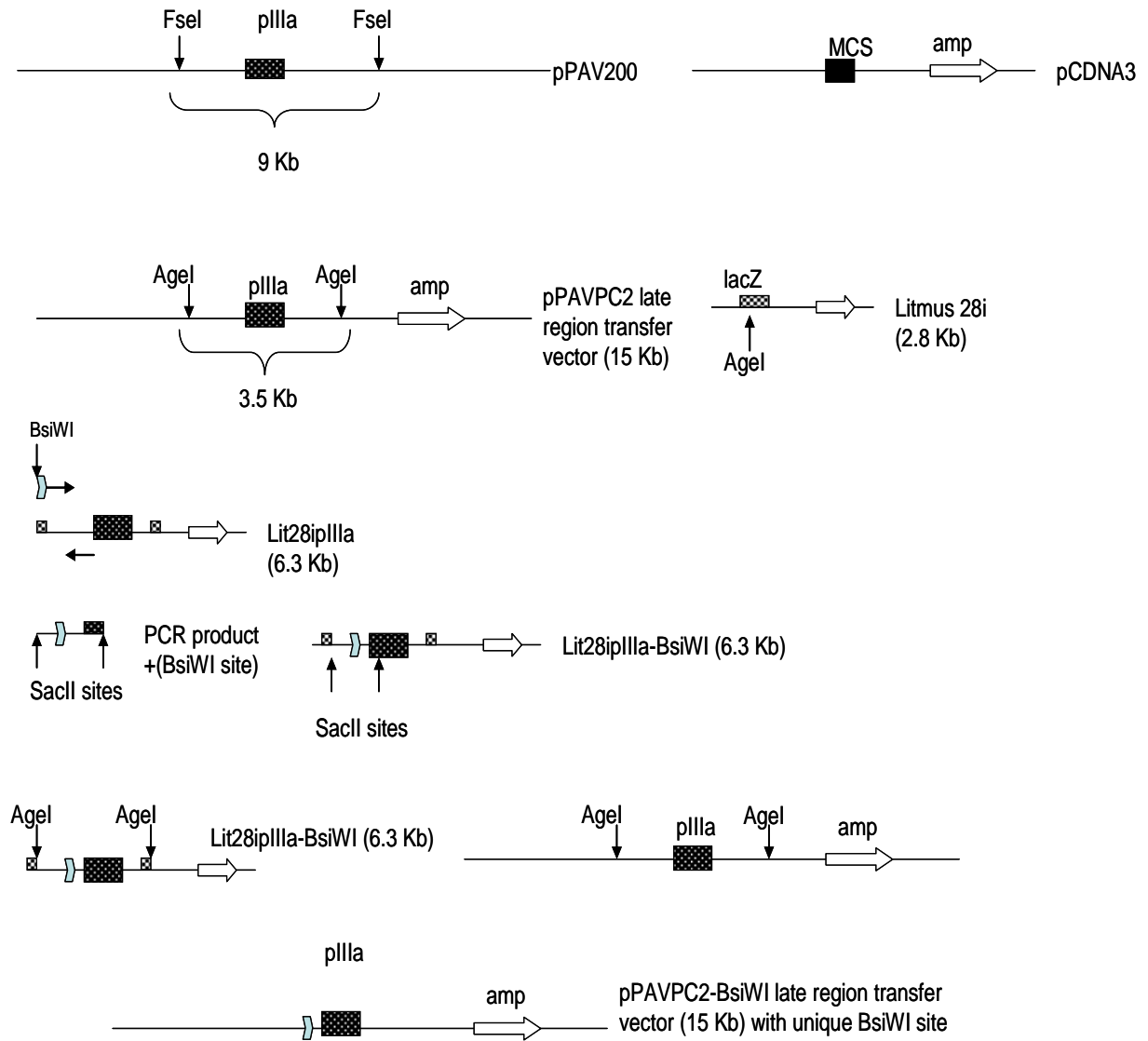


Fig. 7. Construction of PAdV-3 late region transfer vector. Schematic illustrating the stepwise construction of the plasmid pPAVPC2-BsiWI containing a unique BsiWI site 5' to IIIa.

sequenced. (Fig. 8).

4.12.1.3 Construction of pPC2RGD.

A 105 bp oligo pair comprising a RGD motif (box) coupled to a GS linker (5 glycine-serine repeats(in italics)) described previously, (Zakhartchouk et al, 2004) with an additional FLAG epitope (underlined in bold), GTA CGG ATG GCC TGC GAC TGT CGC GGC GAT TGT TTT TGC GGT GGA GTT *GGA TCA GGA TCA GGT TCA GGG AGT GGC TCT* **GAT TAT AAG GAC GAT GAT GAC AAG** GGC was synthesized by Invitrogen. The oligos, when annealed, had the unique BsiWI overhangs and were ligated directly into pPAVPC2 digested with BsiWI as shown in Fig. 8. Positive clones were again screened by restriction enzyme digest and sequenced.

4.12.1.4 Construction of plasmids pFPAV750 and pFPAV751

To generate full length recombinant plasmid DNA via homologous recombination, pPAV200 was linearized with BstBI restriction enzyme and incubated with either pEYFPIIIa or pRGDIIIa digested with EcoRI and BstZ17I in *Escherichia coli* BJ5183 (Chartier et al, 1996) as shown in Fig. 9. Recombinant viral DNA was characterized with restriction enzyme analysis, scaled up and purified for transfection.

4.12.1.5 Rescue of recombinant PAdV-3

Monolayers (80% confluent) of ST cells grown in one well of 6 well tissue culture plates were transfected with either 5 µg or 7 µg of PacI digested pPAV750 (EYFP) , pPAV751 (RGD), or pFPAV701 (positive control) plasmid DNA using Lipofectin (Invitrogen) as per manufacturer's directions. Six hours post transfection, the cells were incubated in MEM containing 5%FBS. The monolayers were observed for development of cytopathic effects and expression of EYFP using the Zeiss Axiovision software.

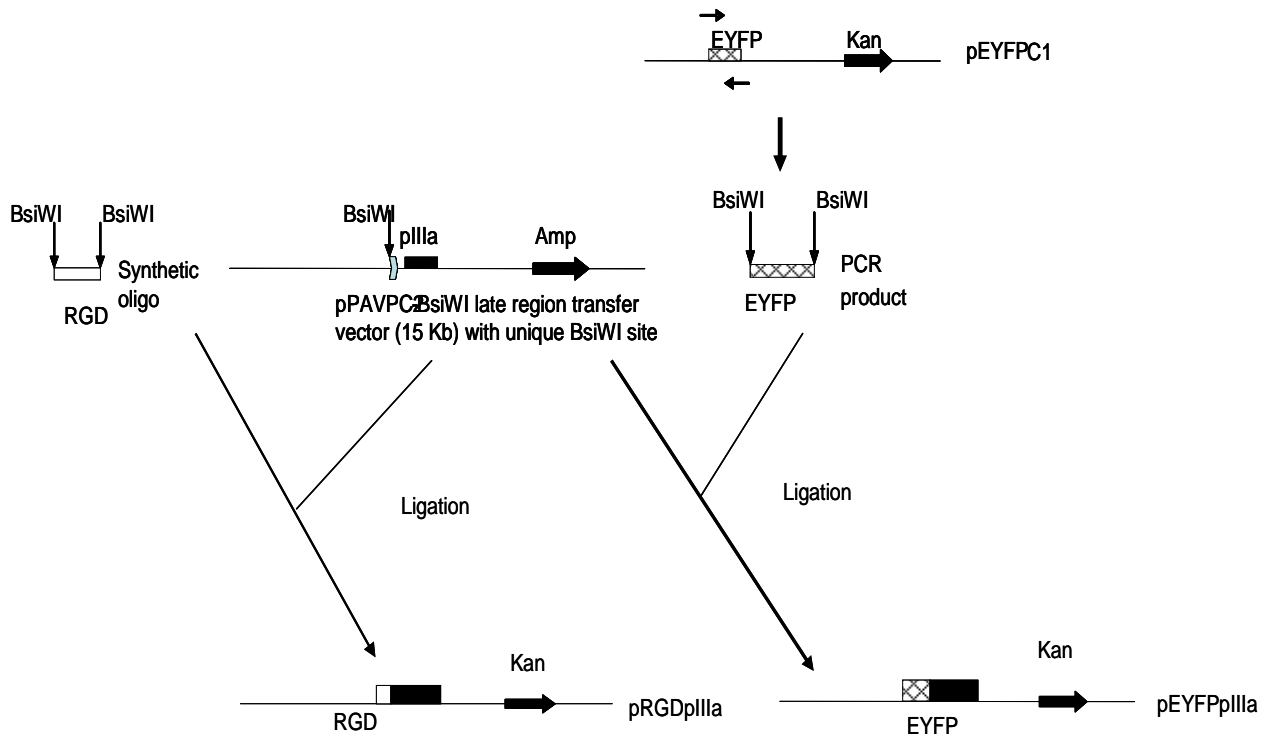


Fig. 8. Construction of recombinant transfer vectors. EYFP was PCR amplified and ligated 5' to IIIa via the unique BsiWI site in pPAVPC2-BsiWI to create plasmid pEYFPpIIIa. Likewise, the synthetic RGD-GS-FLAG oligo was ligated 5' to IIIa in the same late region transfer vector using the unique BsiWI site to create plasmid pRGDpIIIa.

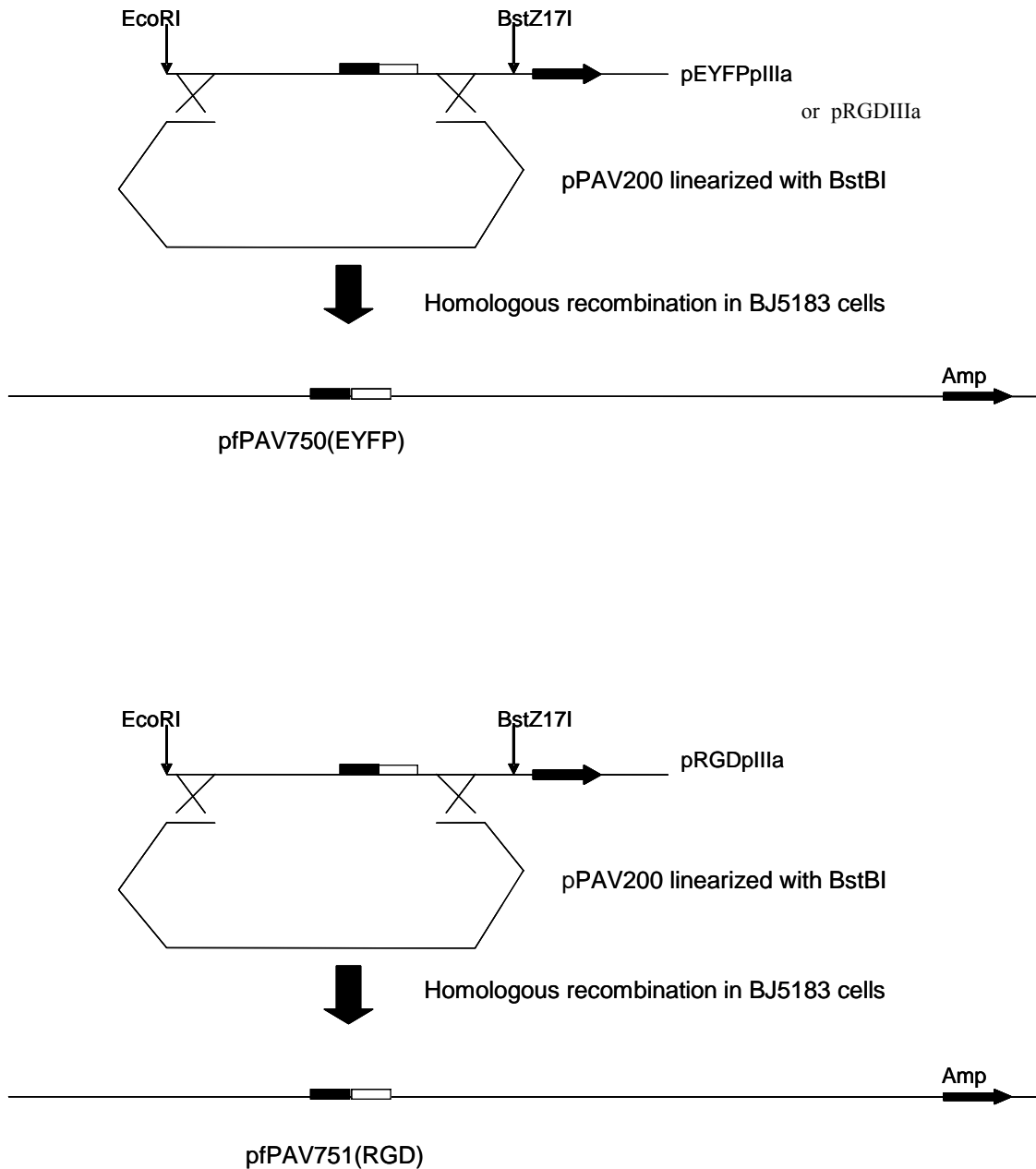


Figure 9. Homologous Recombination Schematic. Full length pPAV200 encoding WT PAdV-3 was linearized with *BstBI* and incubated together with either pEYFP_{IIIa} or pRGD_{IIIa} digested with *EcoRI* and *BstZ17I* in BJ5183 *E.coli* cells. Full length plasmids pfPAV750 (containing EYFP) and pfPAV751 (containing RGD) were created.

5.0 RESULTS

5.1 Analysis of PAdV-3 IIIa

5.1.1 Production of Antibodies

To identify and characterize the IIIa protein in detail, we produced antisera using GST-IIIa fusion proteins and IIIa specific peptides. Initially, the antigenic regions from both the amino (22-158 AA) and carboxyl (480-610 AA) termini were amplified by PCR and separately fused in frame to a gene encoding GST in pGEX-5X-1(Pharmacia) vector. The nucleotide sequence at the junctions between GST and IIIa was confirmed by DNA sequence analysis. The BL21 strain of *Escherichia coli* was transformed with individual plasmid DNA. GST-IIIa fusion protein production was induced by IPTG and the cell lysates were analysed by 10% SDS-PAGE and visualized by staining the gel with Coomassie blue (Fig. 10).

Despite optimization of BL21 growth conditions and addition of protease inhibitors, the carboxy terminal fusion protein (expected size of 66kDa) proved unstable as compared to the amino terminal fusion protein (Figure 10, lanes 6 and 8). To produce antisera against the C-terminus of IIIa, two antigenic peptides of 14 (541-554 AA) and 23 (592-614 AA) amino acids were synthesized and individually coupled to a carrier molecule KLH. The purified proteins or KLH-peptides were used to immunize rabbits. Sera collected after the third boost were then analyzed in detail. The sera were designated as IIIaP1 (541-554 AA) and IIIaP2 (592-614 AA)

5.1.2 *In vivo* expression of IIIa

In order to confirm the specificity of the antisera and to determine the size of IIIa expressed in PAdV-3 infected cells, immunoprecipitation experiments were carried out. ³⁵S-met/cys labelled proteins from mock or PAdV-3 infected cell lysates were immunoprecipitated with antisera to both the amino and carboxy terminal regions of IIIa and analysed by SDS-PAGE. As seen in figure 11, anti-serum to IIIaP2 gave a specific 70kDa band at 48 h p.i. (lane 1) that was not present in the prebleed control (lane 2) or the mock infected cells (lane 3). Anti-serum to IIIaP1 did not show this 70kDa band at 48 h p.i. (lane 4) as well as prebleed (lane 5) or mock infected (lane 6). Anti-serum to IIIaGST gave a very strong band running at 70kDa in both 48 h p.i. (lane 7) and 30 h p.i.

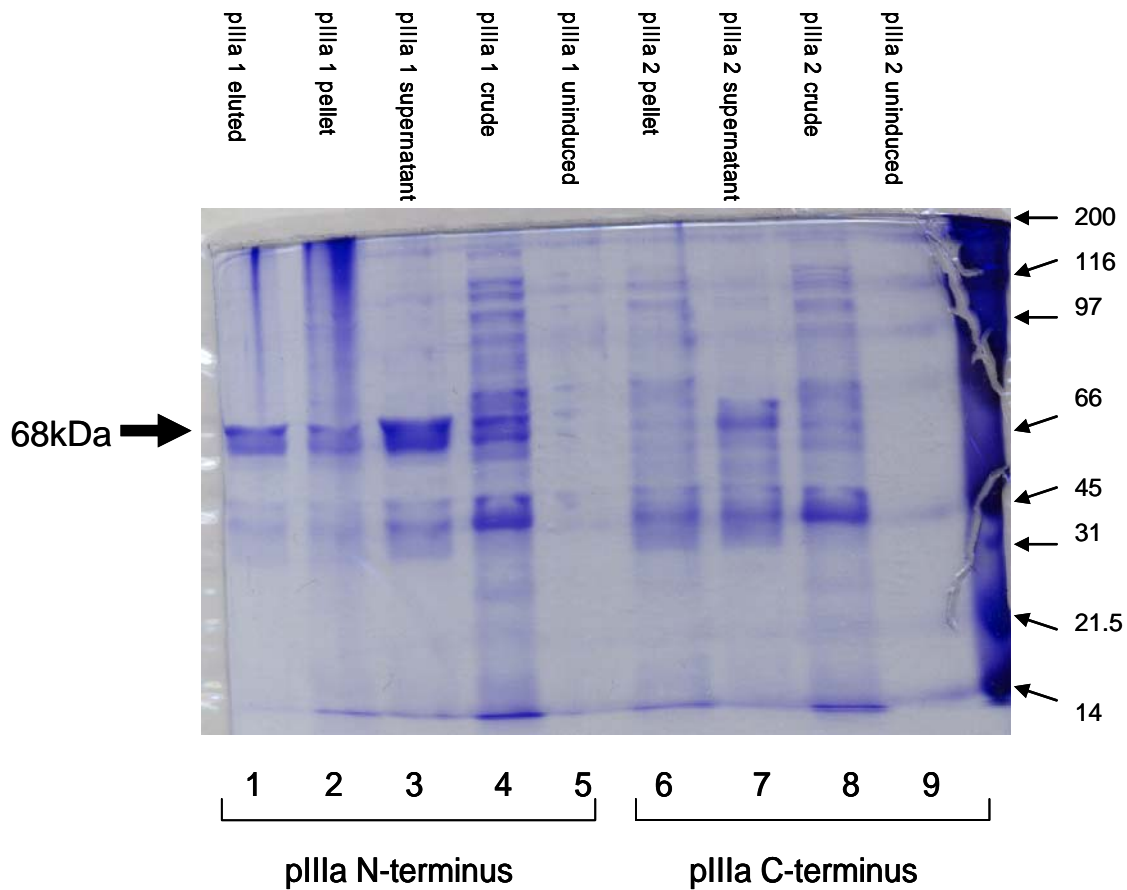


Fig. 10. PAdV-3 IIIa amino and carboxy terminal GST fusion protein expression. A 136 amino acid hydrophilic region representing the amino terminus of IIIa was cloned into pGEX-5-1 GST expression vector (Pharmacia) and propagated in BL21 strain of *E.coli*. Similarly a 130 amino acid hydrophilic region representing the carboxy terminus of IIIa was cloned into pGEX-5-1 GST expression vector and propagated in BL21 strain of *E.coli*. Cultures were induced with IPTG and grown at 30°C. Extracted proteins were separated on 10% SDS-PAGE, stained with Coomassie brilliant blue. Lanes 1 through 5 illustrate the IIIa amino-terminal GST-fusion and lanes 6 through 9 illustrate the IIIa carboxy-terminal GST-fusion following sonication alone (crude) or sonication /centrifugation to generate soluble (supernatant) and insoluble (pellet) protein fractions were checked for purity and specific sizes by SDS-PAGE and Western blotting (not shown) using anti-GST serum. The arrow indicates the expected size of the IIIaGST amino-terminal fusion protein (68 kDa).

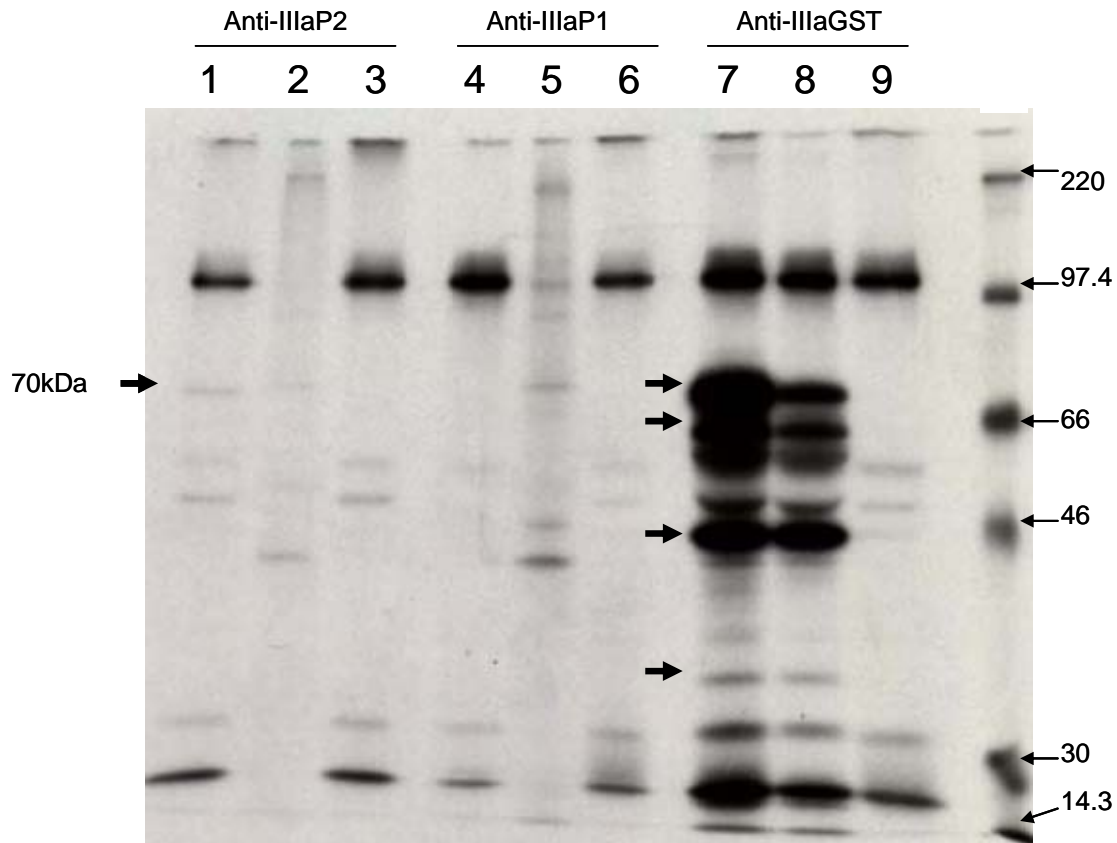


Figure 11. Immunoprecipitation using antiserum to PAdV-3 IIIa. ST cells were infected with PAdV-3 and labeled with ^{35}S 24 h p.i. Cells were harvested at 30 h (lane 8) and 48 h (lane 7) p.i., sonicated and incubated with anti-IIIa serum. Immunoprecipitated complexes were separated on 12.5% SDS-PAGE and exposed to autoradiograph. Anti-IIIaP2 (lane 1) and anti-IIIaGST (lanes 7 and 8) bound to proteins running at the expected 70kDa size for PAdV-3 IIIa. No such band was visible in prebleed sera (lanes 3, 6 and 9) or in mock infected cells (lanes 2 and 5). Amounts of IIIa 70 kDa protein were greater at 48 hours p.i. (lane 7) than 30 hours p.i. (lane 8). Additional specific bands (black arrows) running at approximately 62kDa, 46kDa, 36kDa were present in lanes 7 and 8 and are not present in mock infected or pre-bleed samples. Positions of molecular weight markers in kilodaltons (lane 10) are shown to the right of the panel.

(lane 8) which is not present in the prebleed control (lane 9) In addition, there are specific bands present in lanes 7 and 8 running at approximately 62kDa, 46kDa and 36kDa (Fig. 11) that may represent post- translational modification of PAdV-3 IIIa or alternate proteins binding to IIIa during the course of infection. Alternatively, the presence of extra bands may be the result of proteolytic cleavage of the IIIa proteins during overnight incubation at 4 °C to give various truncated forms of the intact protein.

5.1.3 Western Blot analysis

To further characterize the IIIa protein and confirm whether different bands observed in the immunoprecipitation studies represent post translationally modified forms of IIIa or cellular/viral proteins that coimmunoprecipitate with the 70kDa protein, we carried out a Western blot analysis. As seen in Fig. 12, anti-IIIaGST (against amino terminus, lane 2) or anti-IIIaP2 (against 23 a.a peptide of carboxy terminus, lane 4) detected only a 70 kDa protein in PAdV-3 infected cells. No such protein could be detected using anti-IIIaP1 sera (against 14 a.a peptide of carboxy terminus, lane 9) or prebleed sera (lanes 1,3, and 8).

5.1.4 Immunostaining

To determine the intracellular distribution of IIIa in PAdV-3 infected cells, ST cells were infected with wild-type PAdV-3 at an MOI of 1. After 48 h post-infection, infected cells were fixed and stained with anti-IIIa sera. As seen in fig. 13, panel B, IIIa was detected predominantly in the nucleus of infected cells.

5.1.5 Detection of IIIa in mature capsids

In order to determine if the IIIa protein is part of the mature virion capsids, Western blot analysis was performed using CsCl gradient purified wild-type PAdV-3 virions. As seen in Fig. 14, anti-IIIaGST serum detected a protein of 70 kDa (lane 3). Similarly, anti-IIIaP2 (lane7) and anti-PAdV-3 sera (lane 8) detected a protein of 70 kDa. No such protein could be detected using anti-IIIaP1 serum (lane 5) or prebleed sera (lanes 2,4,and 6).

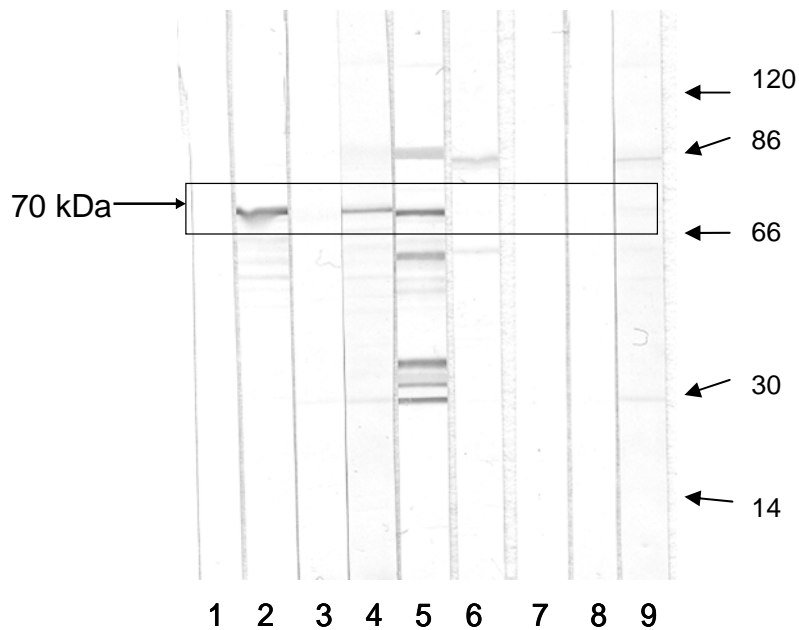


Fig. 12. Western Blot Analysis of PAdV-3 Infected Cells. ST cells were infected with PAdV-3 and harvested 48 h p.i. Proteins were separated by 10% SDS-PAGE. Following transfer of proteins to nitrocellulose, the blot was cut into strips and incubated with with prebleed serum control (lane 1), anti-IIIaGST serum (lane 2), prebleed serum control (lane 3), anti-IIIaP2 serum (lane 4), anti-PAdV-3 (whole virus) serum positive control (lane 5), anti-BAdV-3 (whole virus) serum negative control (lane 6), prebleed serum control (lane 8) and anti-IIIaP1 serum (lane 9). Lane 7 is a negative control lacking primary antibody. PAdV-3 anti-IIIaGST and anti-IIIaP2 serum bind to a protein of expected 70kDa size in infected ST cells but anti-IIIaP1 serum does not. No bands are present in the prebleed serum (lanes 1,3, and 8). Molecular weight in kilodaltons is shown to the right of the panel.

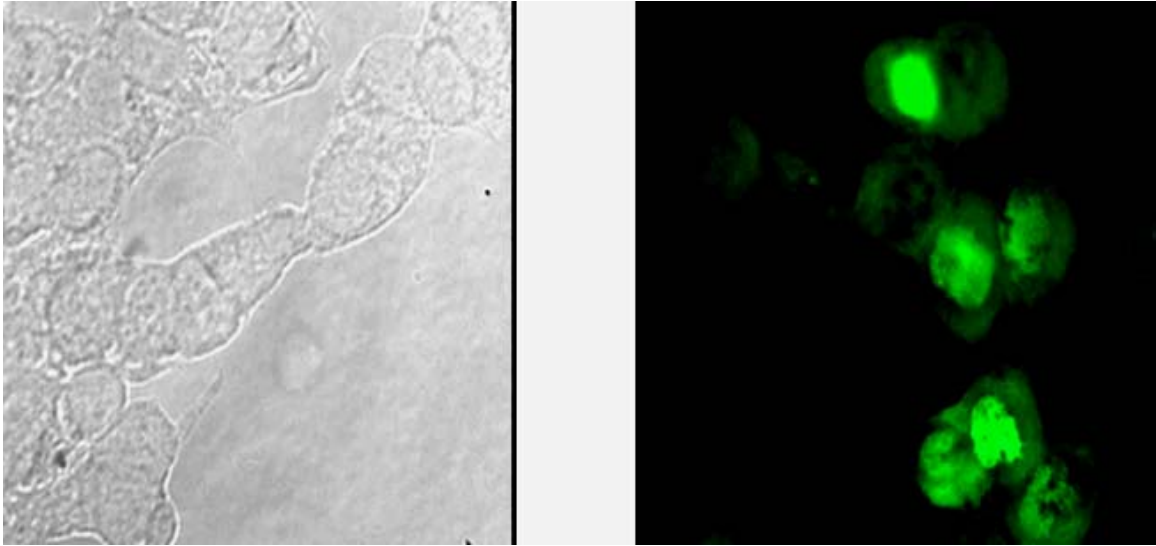
A**B**

Fig. 13. Analysis of cellular distribution of IIIa. PAdV-3 infected ST cells were fixed with methanol-acetone at 24 hours p.i. and subcellular location of IIIa was determined by indirect immunofluorescence using anti-IIIaGST serum at 1:100 dilution (panel B) and transmitted light (panel A) using Zeiss AxioVision viewer software.

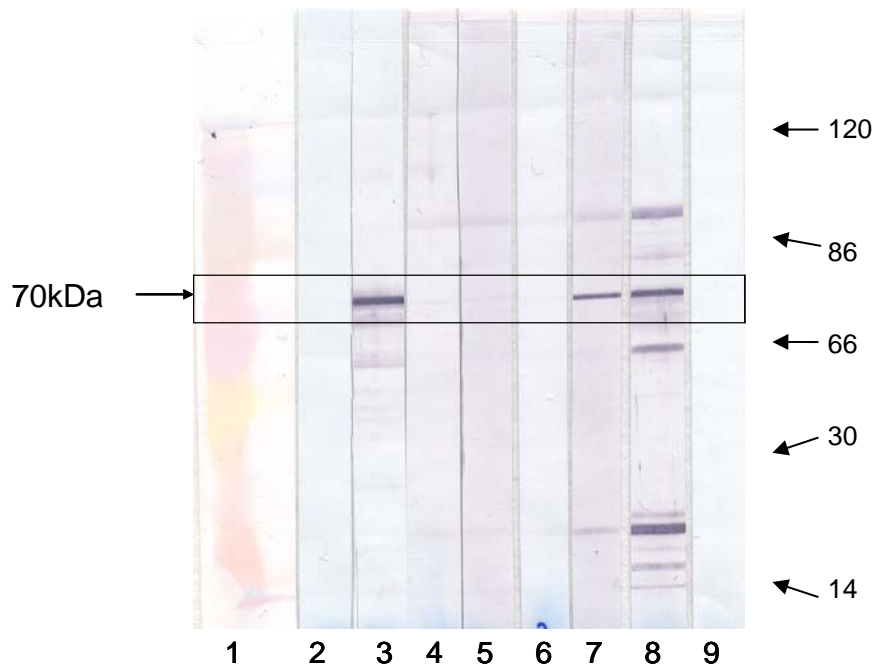


Fig. 14. Western Blot analysis of PAdV-3 virions. Cesium chloride purified PAdV-3 virus was boiled in Laemmli loading sample buffer with β ME, and viral proteins were separated on a 10% SDS-PAGE gel. Following transfer of proteins to nitrocellulose, the blot was cut into strips and incubated with prebleed serum control (lane 2), anti-IIIaGST serum (lane 3), prebleed serum control (lane 4), IIIaP1 antiserum (lane 5), prebleed serum control (lane 6) and anti-IIIaP2 serum (lane 7), PAdV-3 (whole virus) antiserum positive control (lane 8) and anti-BAdV-3 (whole virus) serum negative control (lane 9). Anti-IIIa serum detected only the specific 70kDa band corresponding to PAdV-3 IIIa in purified virions. Molecular weight in kilodaltons is shown to the right of the panel.

5.2 Immunogold staining of PAdV-3 virions

To determine the antigenic regions of IIIa exposed on the viral capsid, immune electron microscopy was performed using CsCl gradient purified virions and IIIa specific antisera. Briefly, purified PAdV-3 was adsorbed onto paraffin coated nickel grids, dried and incubated with anti-IIIa sera. Bound antibodies were then detected with gold conjugated goat anti-rabbit IgG. Although partially disrupted capsids of virions (by visual analysis) were labeled with anti-IIIaGST serum, no intact PAdV-3 virion appeared to be clearly positive for labeling with anti-IIIaGST serum (Fig. 15, panel A and B). As seen in Fig. 14, panel C, intact PAdV-3 virions could be labeled with anti-pIX serum as pIX is accessible on the virus capsid. Moreover, no labeling of PAdV-3 virions (disrupted/complete) was detected using anti-IIIaP2 sera (Fig. 15, panel D).

5.3 Determination of the IIIa nuclear localization signal (NLS)

Earlier, IIIa was detected predominantly in the nucleus of the PAdV-3 infected cells (Section 5.1.4). To determine if any other viral protein is required for the transport of IIIa to the nucleus, we determined the location of IIIa alone in transfected cells. The IIIa ORF was cloned into the mammalian expression vector pCDNA3 (Invitrogen) under the control of the HCMV promoter and BGH polyA signal. In addition, a series of in-frame deletions (Fig. 16) comprising 400-450 bps were introduced individually into the IIIa ORF by PCR mutation procedures. Mutant IIIa genes were then cloned individually into the mammalian expression vector pCDNA3 (Invitrogen) under the control of HCMV promoter and BGH polyA signal. COS-7 cells transfected with individual plasmid were analyzed by immunofluorescence using anti-IIIaGST. As seen in Fig. 17, (panels A,B,C) similar to PAdV-3 infected cells (Fig. 13), wild-type IIIa (IIIaWT) could be detected predominantly in the nucleus of the transfected cells suggesting that IIIa contains the necessary signals for its nuclear localization. However, analysis of the IIIa amino acid sequence could not identify any putative nuclear localization signal(s) when the sequence was examined using databases ExPASy and PSORTII. As nuclear localization of IIIa in transfected cells is indistinguishable from wild-type IIIa expressed in PAdV-3 infected cells, we used the approach of expressing IIIa deletions in transfected cells to determine the region of IIIa required for its localization to the nucleus. The deleted forms of IIIa

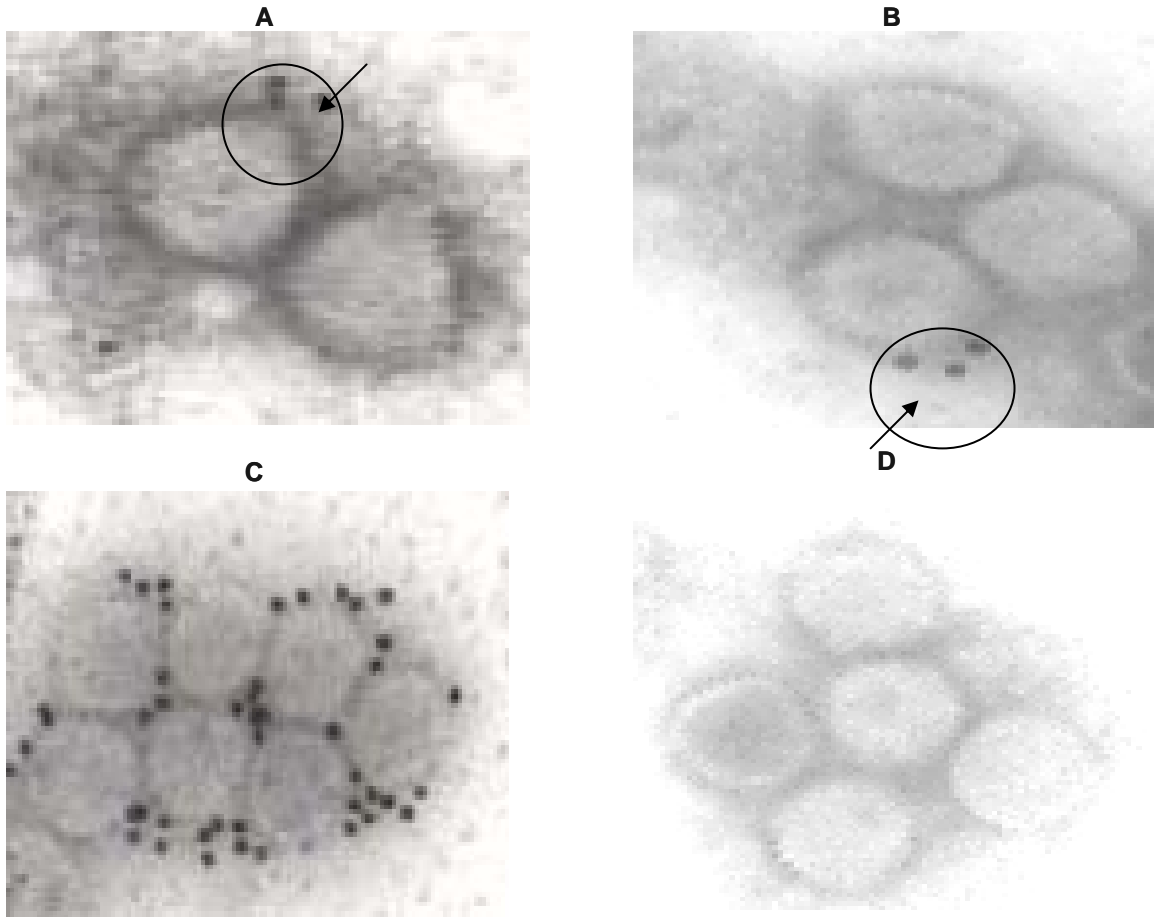


Fig. 15. Immunogold staining of PAdV-3 virions. Samples of CsCl purified wild-type PAdV-3 were adsorbed onto metal EM grids and incubated with anti-IIIaGST sera (panels A and B). Following incubation with gold bead conjugated goat anti-rabbit secondary antibody, the virions were negatively stained with 5% PTA. Panel A and B illustrate some visibly ruptured virus particles (circled) with beads bound to the cellular debris (black arrows) but no binding to intact virions. In contrast, incubation with anti-pIX serum results in clearly positive capsid staining of intact virions (panel C). Incubation with anti-IIIaP2 serum resulted in no binding of gold beads to the PAdV-3 capsid (panel D).

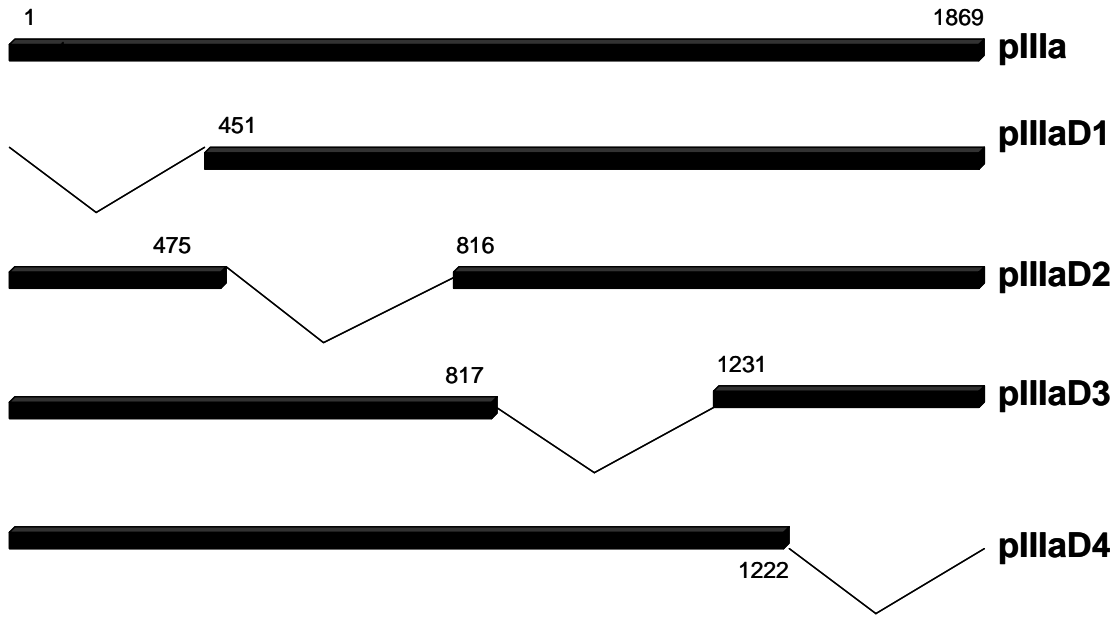


Fig. 16. Schematic representation of IIIa deletion constructs. Deleted regions are indicated by inverted lines and coding regions by filled black boxes. The numbers above the filled boxes indicate the nucleotide numbers of IIIa ORF. The name given to each mutant protein is shown on the left of the panel.

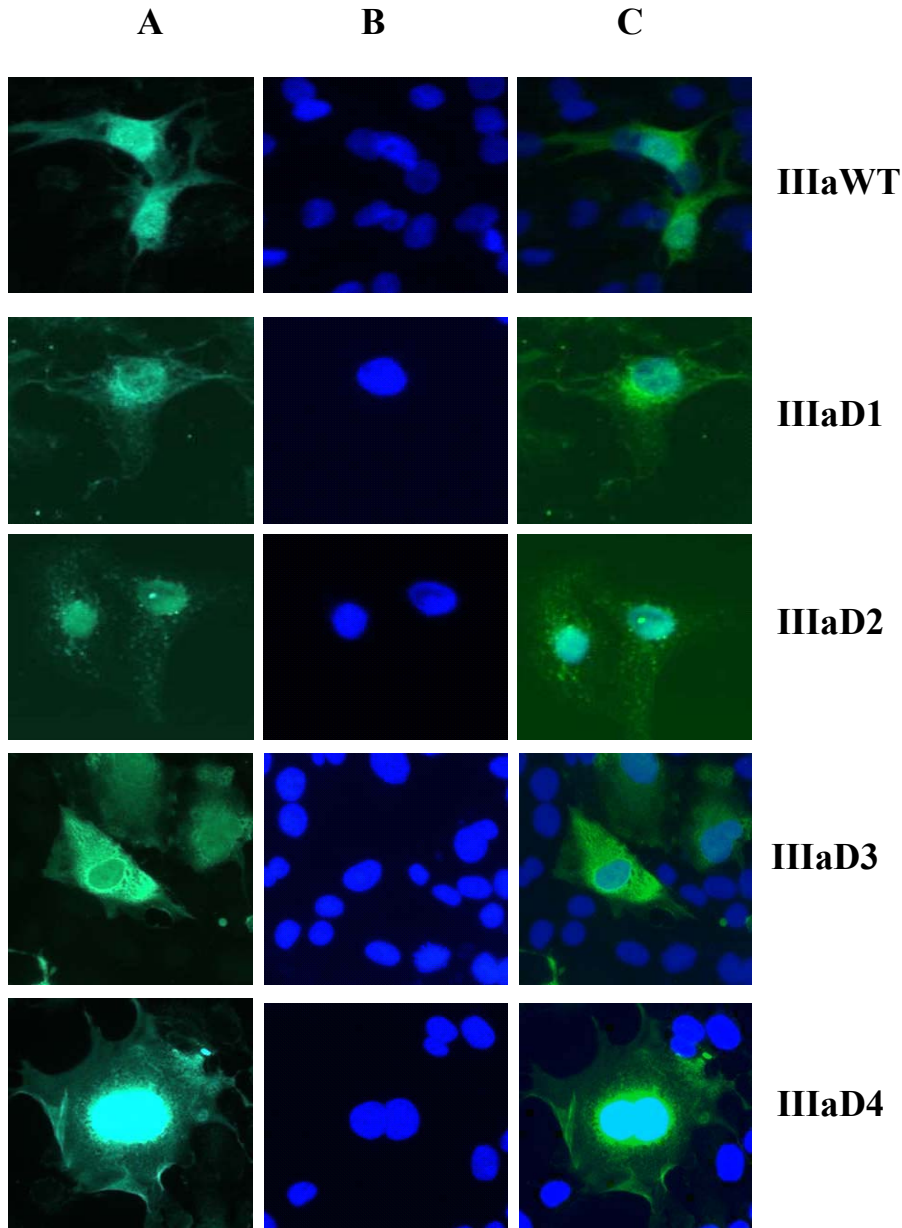


Fig. 17. Subcellular localization of mutant IIIa proteins. COS-7 (2×10^5) cells were transfected with 2 μ g of individual plasmid encoding Wild-type or mutant IIIa proteins. After 48 h of transfection, the cells were fixed with methanol-acetone, and stained with anti-IIIa antibodies. Following incubation with Cy2TM goat anti-rabbit IgG(H+L), nuclei were stained with DAPI and viewed under fluorescent microscope. Immunofluorescence (panel A); DAPI staining (panel B); Merge of immunofluorescence and DAPI (panel C). IIIaWT (Wild-type IIIa); IIIaD1 (IIIa containing deletion of 150 AA); IIIaD2 (IIIa containing deletion of 113 AA); IIIaD3 (IIIa containing deletion of 138 AA); IIIaD4 (IIIa containing deletion of 215 AA).

expressed by IIIaD1, pIIID2 and IIIaD4 localized predominantly in the nucleus of the transfected cells (Fig. 17) . In contrast, the deleted form of IIIa expressed by IIIaD3 localized predominantly in the cytoplasm of the transfected cells (Fig. 17).

Next, we evaluated whether the 415 bp (deleted in IIIaD3) could direct the import of EYFP into the nucleus. This 138 amino acid region of IIIa (amino acids 272-410) was fused 5' to EYFP creating plasmid pNLS EYFP. The junction of the sequences encoding IIIa - EYFP was sequenced to ensure that the coding domains are in frame. As seen in Fig. 18, chimeric IIIa-EYFP protein was detected in both nucleus and cytoplasm of the transfected cells. Plasmid control (pEYFP-N1 backbone vector) showed EYFP localized to the cytoplasm of transfected cells (data not shown).

5.4 IIIa – protein (viral) interactions

As protein–protein interactions are involved in the multi-step assembly process of adenovirus virions, it was speculated that IIIa may interact with other proteins to perform different functions.

5.4.1 Yeast 2 hybrid analysis of IIIa

To characterize the interactions of IIIa with other structural and or regulatory proteins during infections, the Matchmaker GAL4 two-hybrid system 3 (BD Biosciences, Palo Alto, Ca) was used. In this system, two plasmid borne gene fusions are cotransformed into yeast cells, and the interaction between these two fusion proteins is measured by the reconstitution of a functional transcriptional activator that triggers the expression of reporter genes *lacZ*, *HIS3* and *ADE2* contained within the yeast. The gene encoding IIIa was cloned into the pGBK-T7 BD vector and used as bait while ORFs representing different viral proteins of PAdV-3 cloned into pGAD-T7 AD vector (Singh et al, 2005, Table 2) were used as prey. Plasmid pGAD-T7 AD backbone and plasmid pGAD–T(containing non specific SV40 large T antigen) were used as negative controls. As seen in Fig. 19, IIIa appears to interact with all PAdV-3 viral proteins (panels A,B,C) and negative controls (panel D), as intense blue yeast colonies could be detected within 3-4 days of incubation at 30°C on the highest stringency medium (lacking leucine, tryptophan,

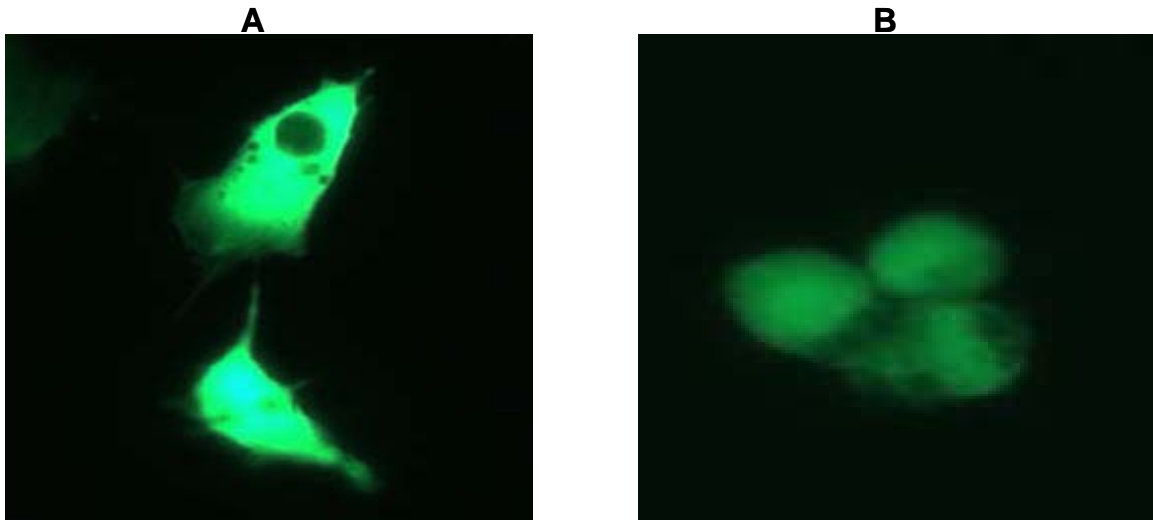


Fig. 18. IIIa NLS analysis. pNLS EYFP was transfected into COS-7 cells and subcellular localization of the putative NLS for IIIa fused to EYFP was viewed directly using the Axiovision viewer software. EYFP expression was seen localized to both the cytoplasm (panel A) and the nucleus (panel B) of transfected cells.

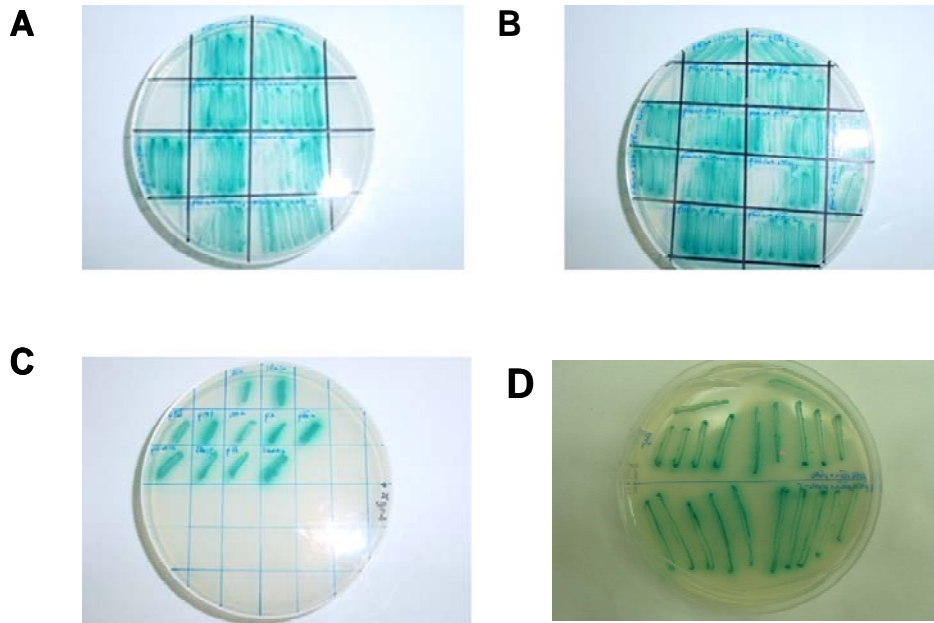


Fig. 19. Yeast Two Hybrid assay. pGBKIIIa BD plasmid was transformed into yeast strain Y187 and mated to yeast strain AH109 transformed with the individual plasmid pGAD-AD containing PAdV-3 genes. Yeast positive for diploids were streaked onto medium stringency plates lacking leucine, tryptophan and histidine containing X- α -gal. Panels A and B show colony growth and blue color indicating putative positive interactions between PAdV-3 IIIa and other PAdV-3 viral proteins. Panel C illustrates these same “positive” interactions when re-streaked from medium to highest stringency medium lacking tryptophan, histidine, adenine and containing X- α -gal. Colony growth and blue color were observed within 3 days post-plating. Panel D shows interaction of IIIa and empty pGAD-AD vector [negative control] (top of plate) as well as interaction between IIIa and pGAD-T, containing SV40 large T antigen, [negative control] (bottom of plate). Colony growth and blue color were apparent on negative controls within 3 days post-plating.

histidine and adenine). In addition, when yeast containing plasmid pGBK-IIIa BD alone was plated on medium stringency medium, there was production of blue colour. This suggests that PAdV-3 IIIa may be a transactivating protein capable of transcriptional activation of the yeast *lac Z* gene without interacting with other viral proteins.

5.4.2 Co-immunoprecipitation of viral proteins with PAdV-3 IIIa

To examine whether PAdV-3 IIIa interacts with other viral proteins during infection, antiserum to a panel of PAdV-3 viral proteins was used to co-immunoprecipitate other interacting viral proteins from lysates of PAdV-3 infected ST cells. Monolayers of ST cells (1×10^5 per well) in one well of 6 well tissue culture dishes were infected with wild-type PAdV-3 at an MOI of 10. At 48 h post infection, proteins from lysates of PAdV-3 infected cells were immunoprecipitated (as described in section 4.10) using protein specific antibodies (section 4.10, Table 4) and analyzed on 12.5% SDS-PAGE. The separated proteins were transferred to nitrocellulose and analyzed by Western blotting (described in section 4.4) using anti-IIIaGST serum. As seen in Fig. 20, anti-IIIa detects a protein of 70 kDa in infected cell lysates immunoprecipitated with anti-fiber serum (panel A, lane 2), anti-hexon serum (panel A, lane 5), anti-pIX serum (panel A, lanes 6 and 7), anti-IIIa serum positive control (panel A, lane 9), anti-13.7K serum (panel A, lane 10) and anti-DBP serum (panel B, lane 5). In contrast, only IIIaGST positive control serum (panel C, lane 6) detected a protein of 70 kDa and anti-pIX serum (panel C, lane 5) detected a protein of 23 kDa in infected cell lysates immunoprecipitated with anti-IIIaGST serum. Anti-fiber sera (panel C, lane 1), anti-hexon sera (panel C, lane 2), anti-13.7K sera (panel C, lane 3) and anti-DBP sera (panel C, lane 4) did not detect any protein in infected cell lysates immunoprecipitated with anti-IIIaGST serum. However, antiserum to PAdV-3 whole virus used as a positive control (panel C, lane 6) detected multiple proteins migrating at 70 kDa, 62 kDa, and 36 kDa respectively. Appearance of other fainter bands in lanes 1 and 4 represent cross-reactive proteins that are bound non-specifically by antiserum to IIIa protein.

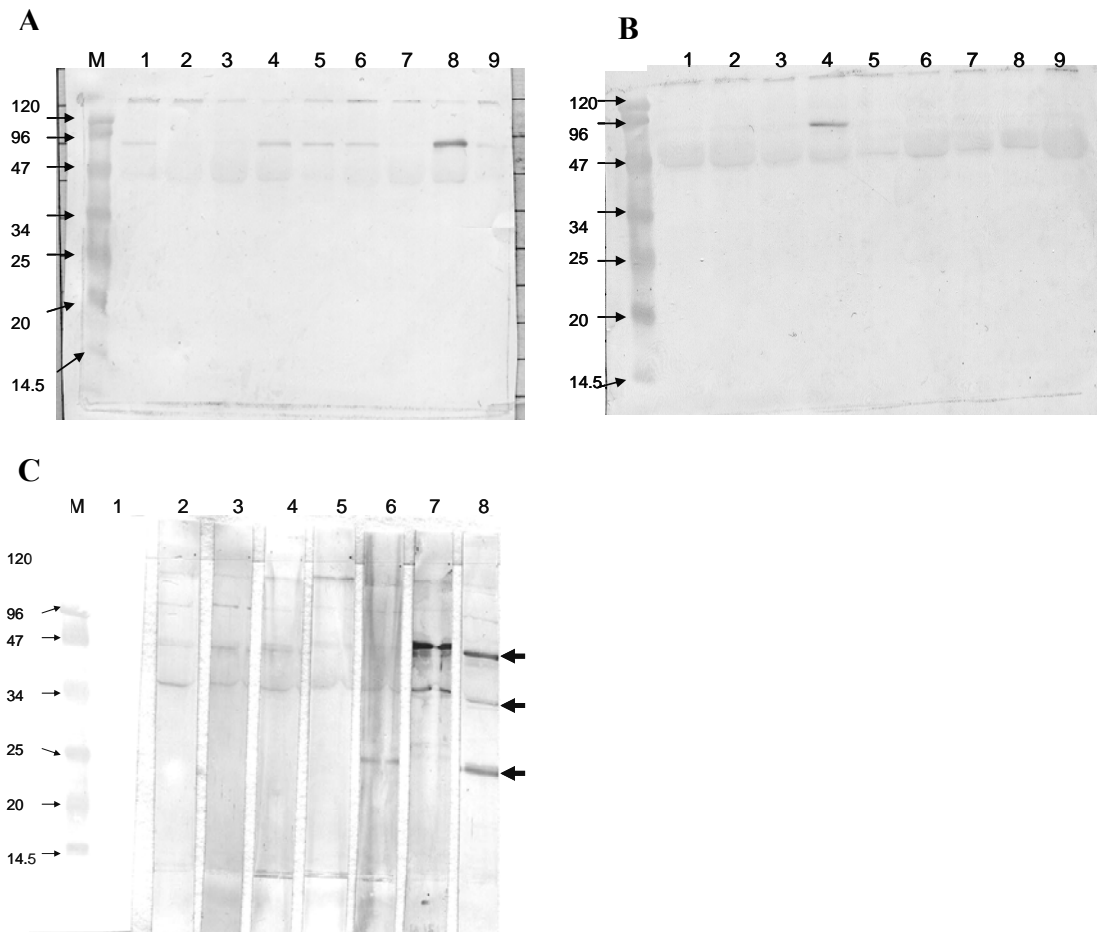


Fig. 20. Co-immunoprecipitation of PAdV-3 viral proteins.

(A) Proteins from lysates of PAdV-3 infected ST cells were immunoprecipitated with anti-fiber serum (lane 2), anti-hexon serum (lane 5) anti-pIX serum (lane 6,7), anti-52K serum (lane 8) anti-IIIa serum (lane 9) and anti-E3 13.7 serum (lane 10), separated by 10% SDS-PAGE and transferred to nitrocellulose membrane. The separated proteins were probed in Western blot by anti-IIIaGST serum.

(B) Proteins from lysates of PAdV-3 infected ST cells were immunoprecipitated with anti-E1A serum (lane 2), anti-E1Bs serum (lane 3), anti-E1BL serum (lane 4), anti-DBP serum (lane 5), anti-E4 orf 2 serum (lane 6), anti-E4 orf 3 serum (lane 7), anti-E4 orf 4 serum (lane 8), anti-E4 orf 7 serum (lane 9) and anti-IVa2 serum (lane 10), separated by 10% SDS-PAGE and transferred to nitrocellulose. The separated proteins were probed in Western blot by anti-IIIaGST serum

(C) Proteins from lysates of PAdV-3 infected ST cells were immunoprecipitated with anti-IIIaGST antiserum, separated by 10% SDS-PAGE and transferred to nitrocellulose. The separated proteins were probed in Western blot by normal prebleed serum (lane 1), anti-fiber serum (lane 2), anti-hexon serum (lane 3), anti-E3 13.7 serum (lane 4), anti-DBP serum (lane 5), anti-pIX serum (lane 6), anti-IIIaGST serum (lane 7), and anti-PAdV-3 (whole virus) serum (lane 8).

5.5 Transcriptional Activation Assay

To determine if IIIa can act as a transactivator, plasmid IIIaWT containing full length IIIa was co-transfected into COS-7 cells, together with plasmid pGL-MLP (Fig. 6), containing a luciferase reporter gene under the control of PAdV-3 major late promoter (MLP), or with plasmid pGL-E1A (Fig. 6), containing a luciferase reporter gene under the control of the PAdV-3 E1A promoter. As seen in Fig. 21, the luciferase expression increased 3-fold when pCDNAIIIa was co-transfected with the pGL-MLP. However, there was no increase in luciferase expression when pCDNAIIIa was co-transfected with the pGL-E1A.

To delineate the transactivating domain of IIIa, the effect of a set of IIIa deletions (described in section 4.7) on transactivation of MLP was examined. The IIIa-induced stimulation of PAdV-3 MLP was moderately affected by deletion of amino acids 138-272 (MLP del2). However, deletion of amino acids 272-410 (MLP del3) or amino acids 410-622 (MLP del4) of IIIa completely eliminated the transactivation of MLP. Interestingly, there was no significant effect of IIIa deletions on the transactivation of the E1A promoter. (Fig. 22)

5.6 Construction of IIIa chimeric viruses

In order to reconfirm the immunogold staining observations, attempts were made to construct recombinant PAdV-3 expressing chimeric IIIa (the amino-terminus of IIIa fused to Enhanced Yellow Fluorescent Protein (EYFP) or “RGD” motif). The genes coding for pEYFP-IIIa and pRGD-IIIa were inserted individually into the PAdV-3 genome using homologous recombination machinery of *Escherichia coli* (strain BJ5183) creating plasmids pFPAV750 (chimeric EYFP-IIIa) and pFPAV751 (chimeric RGD-IIIa), respectively (Fig. 23). The identities of the plasmids were confirmed by restriction enzyme analysis of plasmid DNA. The *PacI* digested pFPAV750, pFPAV751 or pFPAV701 (E3-E4 deleted pFPAV200 expressing EYFP inserted in the E4 region; (Li, and Tikoo, unpublished)) plasmid DNAs were transfected into ST cells or VIDO R1 cells and monitored for the development of cytopathic effects. Repeated transfections of porcine cells with plasmid pFPAV750 or pFPAV751 DNA did not produce any cytopathic effect even after four weeks of transfection. However, transfection of porcine

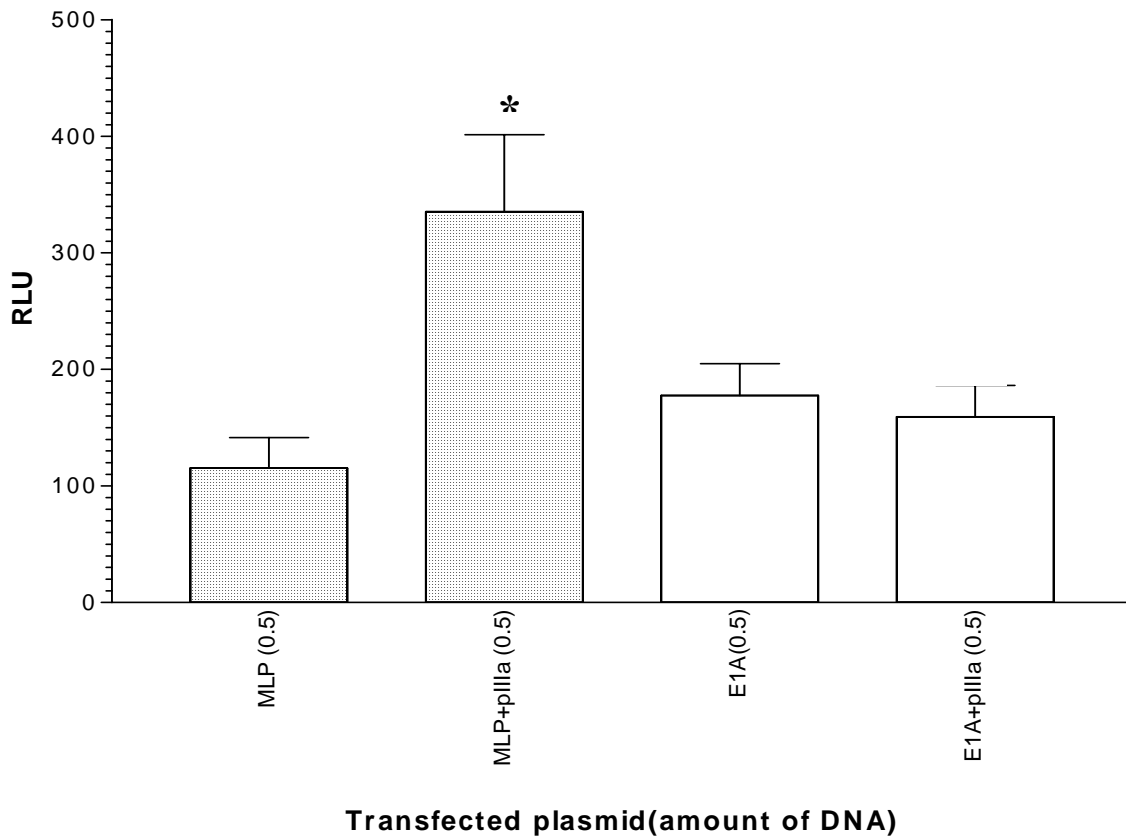


Fig. 21. Transactivation assay. Plasmids containing either the PAdV-3 MLP or PAdV-3 E1A promoters 5' of the luciferase reporter gene in pGL-Basic Vector (Promega) were constructed. COS-7 cells were transfected with 0.5 μ g pGL-MLP or pGL-E1A plasmid alone or together with plasmid IIIaWT containing wild-type PAdV-3 IIIa. The cells were collected 48 h post transfection and analysed for luciferase activity. Values are expressed as relative light units (RLU). Relative luciferase units (means from triplicate wells) are represented with corresponding standard deviations. Presence of IIIa activated the MLP resulting in luciferase expression that was significantly higher than pGL-MLP alone. The statistical differences are indicated by asterisks at the top of the bar. Within promoter type, bars with asterisks are different ($P < 0.05$)

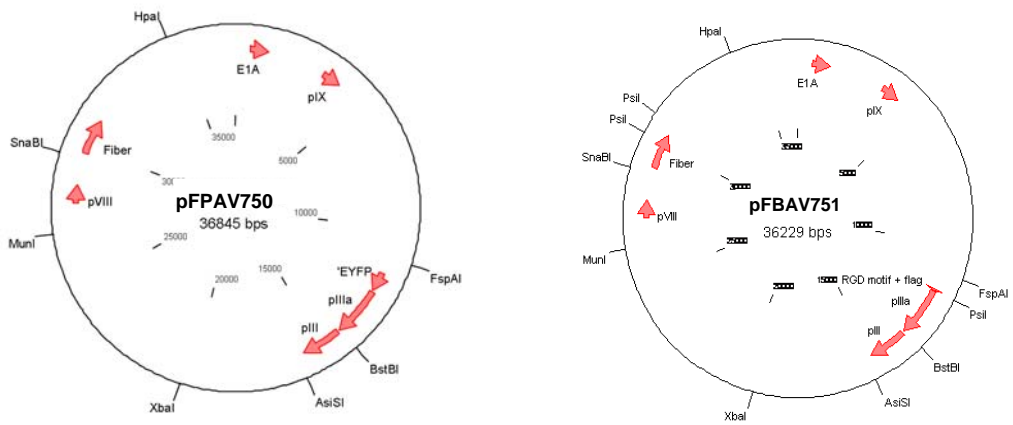


Fig. 23. Schematic diagram of recombinant plasmids. Map of the plasmids depicting the location of different genes and restriction enzyme sites is shown. Plasmid pFPAV750 (full length PAdV-3 containing chimeric IIIa-EYFP), plasmid pFBAV751 (full length PAdV-3 DNA containing chimeric IIIa-RGD) .

cells with pFPAV701 (transfection control) DNA always produced EYFP expression in 48 h and cytopathic effects in 7-10 days (Fig. 24).

6.0 DISCUSSION

The adenovirus capsid is composed of three major structural proteins (fiber, penton, hexon) and five minor structural proteins (IVa2, VI, VIII, IX and IIIa) (Parks, 2004). While major capsid proteins are involved in initial virus cell interactions and induction of neutralizing antibodies (Gall et al, 1996; Dmitriev et al, 1998; Rots et al, 2003; Vellinga et al, 2005; Sumida et al, 2005; Wu et al, 2005), minor structural proteins are thought to act as capsid cement to manage the accurate virus assembly. Although all major capsid proteins have been studied in detail (Amalfitano and Parks, 2002; Vellinga et al, 2005), only two minor capsid proteins (pIX and IVa2) have been the focus of other reports (Lutz and Kedinger, 1996; Lutz et al, 1997; Dmitriev et al, 2002; Parks, 2004). Moreover, recent reports of tolerating significant genetic modification including the addition of large polypeptides as targeting ligands by minor capsid protein pIX (Rosa-Calatrava et al, 2001; Parks, 2004; Sargeant et al, 2004; Zakhartchouk et al, 2004) have generated interest in determining the structure and function of other minor capsid proteins. This thesis reports the structure and possible functions of PAdV-3 IIIa protein.

The IIIa protein of PAdV-3 is 622 amino acids long and shows low overall homology to the IIIa proteins of other adenoviruses (Cuillel et al, 1990; Reddy et al, 1998). Unlike HAdV-5, the PAdV-3 IIIa lacks a consensus protease cleavage sequence (Reddy et al, 1998). Analysis of PAdV-3 IIIa using antibodies against different regions suggested that the N-terminus (amino acid 2-158) and C-terminus (amino acid 592-614) of IIIa were immunogenic. However, it is possible that C-terminus amino acids 541-554 may not contain immunogenic sites (Scheres et al, 2005) (Fig. 11,12 and 14).

Antisera directed against the IIIa protein immunoprecipitated four bands of 70kDa, 62kDa, 46kDa, and 23kDa from PAdV-3 infected cells but not from mock infected cells (Fig.11). However, anti-IIIaGST detected only a 70kDa band in Western blot (Fig.12,14) suggesting that 62kDa, 46kDa, and 36kDa bands represent the cellular or viral proteins coimmunoprecipitated with IIIa. Alternatively, it is also possible that these bands represent proteolytic cleavage products resulting from the overnight incubation with PAS

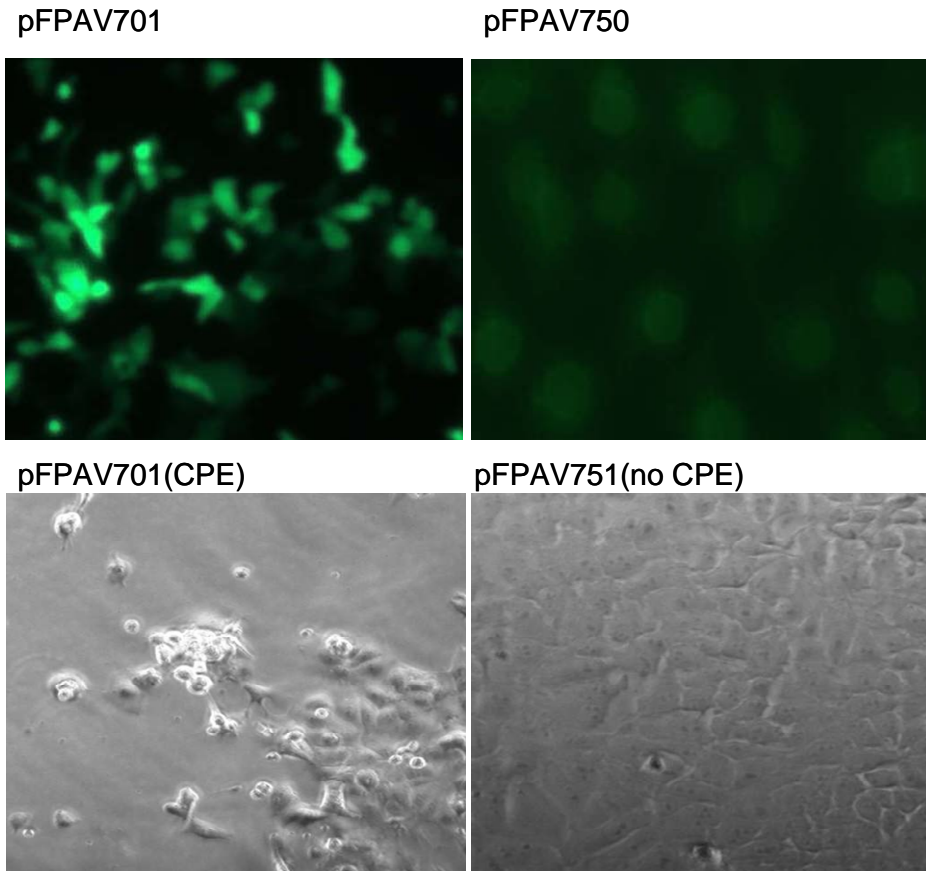


Fig. 24. Rescue of recombinant PAdV-3 IIIa virus. Full-length recombinant plasmids, pFPAV750 (EYFP) and pFPAV751 (RGD) were digested with *PacI* to release the viral coding sequence from the plasmid backbone. The recombinant DNA was transfected into ST cells as well as VIDO RI cells (not shown). pFPAV701 (E3,E4 deleted pFPAV200 expressing EYFP inserted in the E4 region) was also transfected into ST cells as well as VIDO RI cells (not shown) as a positive control. 48 hours post-transfection, cells were viewed under UV microscope to visualize EYFP fluorescence as a measure of transfection efficiency. pFPAV701 positive control shows high transfection efficiency and visible EYFP expression. pFPAV750 shows no EYFP expression. Cytopathic effect (CPE) was observed in pFPAV701 7 days post transfection and was never observed in either pFPAV750 or pFPAV751 transfections up to 4 weeks post transfection. Neither recombinant virus was rescued.

beads. The IIIa protein is localized predominantly in the nucleus of PAdV-3 infected cells (Fig.13) and is incorporated in the capsid of mature PAdV-3 (Fig. 14).

Earlier, studies related to adenovirus structure suggested that HAdV-5 IIIa traversed the capsid width with a rod-like density having one domain near the top of the hexon and another near the bottom of the hexon (Stewart et al, 1993). However, immunogold labeling using anti-IIIa serum (whole protein) only produced label in ruptured HAdV-5 viral particles (Scheres et al., 2005) suggesting that polypeptide IIIa is not accessible to the antibodies from outside the capsid. Interestingly, immunogold labeling using anti-IIIa sera also produced label in partially disrupted PAdV-3 virions but not in intact PAdV-3 virions. This suggested that similar to HAdV-5, neither the N-terminus nor C-terminus of PAdV-3 IIIa is exposed on the surface of PAdV-3 capsid (Fig. 15)

Proteins less than 40 kDa in size can diffuse passively into the nucleus through nuclear pore complexes (Pante and Aebi, 1996). Due to the large size of IIIa, it is unlikely that the IIIa protein enters the nucleus by a simple diffusion. Although numerous studies have demonstrated that active import of large proteins to the nucleus requires distinct amino acid sequences known as nuclear localization signals (NLS) (Dingwall and Laskey, 1991), the presence of a non-conventional motif can also lead to nuclear import of a protein (Pillet et al., 2003). Analysis of mutant PAdV-3 IIIa proteins demonstrated that sequences affecting nuclear localization are located between amino acid 272 and 410 (Fig. 17). Surprisingly, the putative 138 amino acid NLS (amino acid 273-410) was not able to direct predominantly cytoplasmic EYFP efficiently to the nucleus (Fig. 18). This failure to localize to the nucleus may be due to misfolding of the truncated IIIa protein. It is also possible that the sequences identified in PAdV-3 IIIa of PAdV-3 for nuclear transport may depend on the protein to which it is linked or the context of the NLS within the fusion protein. For example, the NLS of GAL4, a yeast DNA-binding protein, functions efficiently when fused to normally cytoplasmic invertase, but not when fused to *E. coli* β -galactosidase (Nelson and Silver, 1989). Moreover, an NLS inserted into several sites within the polypeptide chain of pyruvate kinase could not function in the same locations, as its activity was masked (Roberts et al., 1987). Alternatively, it is possible that NLS-EYFP protein may diffuse between the cytoplasm and nucleus due to

the expected size of the fusion protein (40 kDa) thus perhaps another protein such as β -galactosidase should be used to evaluate IIIa nuclear localization.

Earlier, adenovirus intermediate proteins (pIX and IVa2) have been shown to act as transcriptional activators for MLP, E1A and E4 promoters (Lutz and Kedinger, 1996; Lutz et al, 1997; Rosa-Calatrava et al, 2001; Parks, 2004). Similarly, PAdV-3 IIIa appears to act as a transcriptional activator for MLP (Fig. 19) as it shows significant increase in the expression of luciferase protein when expressed in uninfected cells with pGL-MLP. In contrast, there was no increase in the expression of luciferase protein when PAdV-3 IIIa was expressed in uninfected cells with pGL-E1A (Fig. 21). It is possible that IIIa transactivates MLP by recognizing sequences unique to MLP. Alternatively, it is possible that IIIa provides transactivation function by binding to other cellular proteins (provides specific DNA binding function) with a specific DNA binding activity. Viral transcription regulators can act a) by recognizing specific DNA sequences (Lutz et al., 1997), by interacting with cellular DNA binding proteins, and/or c) by acting as cellular co-factors (Lutz and Kedinger, 1996; Perez-Romero et al, 2005). Further experiments are needed to prove these speculations.

Analysis of the mutant IIIa proteins demonstrated that amino acids 410-622 are involved in the transactivation of MLP. Deletion of amino acids 272-410 also impaired the transcriptional activity of IIIa (Fig. 22). However, this domain is predicted to contain sequences affecting the NLS of IIIa either because of a direct NLS sequence or protein folding. It is possible that the deletion of this domain (amino acid 272-410) would affect the transport of IIIa to the nucleus thereby affecting IIIa's transcriptional activity.

Protein-protein interactions are important for the assembly of adenoviruses and are critical for the function of the multitask proteins. The IIIa of HAdV-5 is known to interact with hexon and is coimmunoprecipitated with fiber (Horwitz, 2004). As expected, PAdV-3 IIIa appears to interact with fiber and hexon, which may help in maintaining the structure of the capsid. However, PAdV-3 IIIa also appears to interact with DBP, E3 13.7K, and pIX (Fig. 20). The exact purpose of these interactions during viral infection of ST cells is not clear. It is possible that interaction of IIIa with DBP or 13.7K is important for molecular recognition of viral DNA thus enabling transcription of other late viral proteins. The binding of IIIa to pIX is intriguing. Based on the current capsid

models, IIIa and pIX appear to be located physically apart and thus can not exist as a complex in the PAdV-3 capsids. It is possible that interaction of IIIa-pIX is important for an unknown step in the capsid formation. Failure of anti-IIIa sera to precipitate the same viral proteins in the reverse coimmunoprecipitation may be in part due to epitope masking (Fig. 20). The IIIa domain bound by the interacting viral proteins may be the same or in close proximity to the epitope recognized by the anti-IIIa antibody, thus when the IIIa protein is bound by said viral proteins, the epitope is not available to the anti-IIIa antibody.

Recombinant HAdV-5 containing chimeric IIIa (IIIa fused to a 6-HIS tag or FLAG epitope) have been isolated. Both of these insertions are extremely small and not likely to interfere with protein folding or functions (Glasgow et al, 2005). Our results suggest that larger insertions are likely not possible and if rescued, the virus may not uncoat or assemble properly and result in abortive infections. Micro-imaging of HAdV-2 capsid suggests that the IIIa protein is present at a 45° angle from the surface (Fabry et al., 2005). As such, large insertions may not be possible simply due to steric hindrance resulting in sub-optimal capsid assembly and this may account for the inability to rescue viable virus from permissive cells (Fig. 24)

7.0 REFERENCES

Amadori A, De Silvestro G, Zamarchi R, Veronese ML, Mazza MR, Schiavo G, Panozzo M, De Rossi A, Ometto L, Mous J, et al. 1992. CD4 epitope masking by gp120/anti-gp120 antibody complexes. A potential mechanism for CD4+ cell function down-regulation in AIDS patients. *The Journal of Immunology* 148: 2709-2716.

Amalfitano A and Parks RJ. 2002. Separating fact from fiction: assessing the potential of modified adenovirus vectors for use in human gene therapy. *Curr. GeneTherapy* 2:111-133.

Arnberg N, Kidd AH, Edlund K, Nilsson J, Pring-Akerblom P, Wadell G. 2002. Adenovirus type 37 binds to cell surface sialic acid through a charge-dependent interaction. *Journal of Virology* 302: 33-43.

Arnberg N, Kidd AH, Edlund K, Olfat F, Wadell G. 2000. Initial interactions of subgenus D adenoviruses with A549 cellular receptors: sialic acid versus alpha(v) integrins. *Journal of Virology* 74: 7691-7693.

Athappilly FK, Murali R, Rux JJ, Cai Z, Burnett RM. 2004. The refined crystal structure of hexon, the major coat protein of adenovirus type 2, at 2.9 Å resolution. *Journal of Molecular biology* 242: 430-455.

Babiuk LA, Tikoo SK. 2000. Adenoviruses as vectors for delivering vaccines to mucosal surfaces. *Journal of Biotechnology* 83: 105-113.

Bai M, Harfe B, Freimuth P. 1993. Mutations that alter an Arg-Gly-Asp (RGD) sequence in the adenovirus type 2 penton base protein abolish its cell-rounding activity and delay virus reproduction in flat cells. *Journal of Virology* 67: 5198-5205.

Bangari DS, Mittal SK. 2004. Porcine adenoviral vectors evade preexisting humoral immunity to adenoviruses and efficiently infect both human and murine cells in culture. *Virus Research* 105: 127-113.

Bangari DS, Shukla S, Mittal SK. 2005. Comparative transduction efficiencies of human and nonhuman adenoviral vectors in human, murine, bovine, and porcine cells in culture. *Biochemical and Biophysical Research* 327: 960-966.

Belousova N, Krendelchtchikova V, Curiel DT, Krasnykh V. 2002. Modulation of adenovirus vector tropism via incorporation of polypeptide ligands into the fiber protein. *Journal of Virology* 76: 8621-8631

Belousova N, Korokhov N, Krendelshchikova V, Simonenko V, Mikheeva G, Triozzi PL, Aldrich WA, Banerjee PT, Gillies SD, Curiel DT, Krasnykh V. 2003. Genetically targeted adenovirus vector directed to CD40-expressing cells. *Journal of Virology* 77:11367-11377

Bendixen C, Gangloff S, Rothstein R. 1994. A yeast mating-selection scheme for detection of protein-protein interactions. *Nucleic Acids Research* 22: 1778-1779.

Benko M, Harrach B. 2003. Molecular evolution of adenoviruses. *Current Topics in Microbiology and Immunology* 272: 3-35

Benson SD, Bamford JK, Bamford DH, Burnett RM. 2004. Does common architecture reveal a viral lineage spanning all three domains of life? *Molecular Cell* 16: 673-685.

Bouri K, Feero WG, Myerburg MM, Wickham TJ, Kovessi I, Hoffman EP, Clemens PR. 1999. Polylysine modification of adenoviral fiber protein enhances muscle cell transduction. *Human Gene Therapy* 10: 1633-1640.

Brandsma JL, Shlyankevich M, Zhang L, Slade MD, Goodwin EC, Peh W, Deisseroth AB. 2004. Vaccination of rabbits with an adenovirus vector expressing the papillomavirus E2 protein leads to clearance of papillomas and infection. *Journal of Virology* 78: 116-123.

Casper JM, Timpe JM, Dignam JD, Trempe JP. 2005. Identification of an adeno-associated virus Rep protein binding site in the adenovirus E2a promoter. *Journal of Virology* 79: 28-38.

Cepko CL, Sharp PA. 1983. Analysis of Ad5 hexon and 100K ts mutants using conformation-specific monoclonal antibodies. *Virology* 129: 137-154.

Chartier C, Degryse E, Gantzer M, Dieterle A, Pavirani A, Mehtali M. 1996. Efficient generation of recombinant adenovirus vectors by homologous recombination in *Escherichia coli*. *Journal of Virology* 70: 4805-4810.

Chroboczek J, Viard F, D'Halluin JC. 1986. Human adenovirus 2 temperature-sensitive mutant 112 contains three mutations in the protein IIIa gene. *Gene* 49:157-160.

Clarke MC, Sharpe HB, Derbyshire JB. 1967. Some characteristics of three porcine adenoviruses. *Arch Gesamte Virusforsch.* 21:91-97.

Cuillet M, Cortolezzis B, Chroboczek J, Langowski J, Ruigrok RW, Jacrot B. 1990. Purification and characterization of wild-type and ts 112 mutant protein IIIa of human adenovirus 2 expressed in *Escherichia coli*. *Virology* 175: 222-231.

Cuillet M, Milleville M, D'Halluin JC. 1987. Expression of protein IIIa of human adenovirus type 2 in *Escherichia coli*. *Gene* 55:295-301.

Curiel DT. Capsid-modified recombinant adenovirus and methods of use. United States Patent # 6,555,368. April 29, 2003.

Dehecchi MC, Melotti P, Bonizzato A, Santacatterina M, Chilosi M, Cabrini G. 2001. Heparan sulfate glycosaminoglycans are receptors sufficient to mediate the initial binding of adenovirus types 2 and 5. *Journal of Virology* 75: 8772-8780.

Derbyshire JB, Clarke MC, Collins AP. 1975. Serological and pathogenicity studies with some unclassified porcine adenoviruses. *Journal of comp Path.* 85: 437-443.

Dingwall C, Laskey RA. 1991. Nuclear targeting sequences--a consensus? *Trends Biochem Sci* 16: 478-481.

Dmitriev IP, Kashentseva EA, Curiel DT. 2002. Engineering of adenovirus vectors containing heterologous peptide sequences in the C terminus of capsid protein IX. *Journal of Virology* 76: 6893-6899.

Dmitriev IP, Krasnykh V, Miller CR, Wang M, Kashentseva E, Mikheeva G, Belousova N, Curiel DT. 1998. An adenovirus vector with genetically modified fibers demonstrates expanded tropism via utilization of a coxsackievirus and adenovirus receptor-independent cell entry mechanism. *Journal of Virology* 72: 9706-9713.

Douglas JT, Miller CR, Kim M, Dmitriev I, Mikheeva G, Krasnykh V, Curiel DT. 1999. A system for the propagation of adenoviral vectors with genetically modified receptor specificities. *Nature Biotechnology* 17: 470-475.

Durmort C, Stehlin C, Schoehn G, Mitraki A, Drouet E, Cusack S, Burmeister WP. 2001. Structure of the fiber head of Ad3, a non-CAR-binding serotype of adenovirus. *Virology* 285: 302-312.

Ehrhardt A, Xu H, Kay MA. 2003. Episomal persistence of recombinant adenoviral vector genomes during the cell cycle in vivo. *Journal of Virology* 77: 7689-7695.

Einfeld DA, Brough DE, Roelvink PW, Kovesdi I, Wickham TJ. 1999. Construction of a pseudoreceptor that mediates transduction by adenoviruses expressing a ligand in fiber or penton base. *Journal of Virology* 73: 9130-9136.

Everett RS, Hodges BL, Ding EY, Xu F, Serra D, Amalfitano A. 2003. Liver toxicities typically induced by first-generation adenoviral vectors can be reduced by use of E1, E2b-deleted adenoviral vectors. *Human Gene Therapy* 14: 1715-1726.

Fabry CM, Rosa-Calatrava M, Conway JF, Zubieta C, Cusack S, Ruigrok RW, Schoehn G. 2005. A quasi-atomic model of human adenovirus type 5 capsid. *The EMBO Journal* 24: 1645-1654.

Farley DC, Brown JL, Leppard KN. 2004. Activation of the early-late switch in adenovirus type 5 major late transcription unit expression by L4 gene products. *Journal of Virology* 78:1782-1791.

Fessler SP, Young CS. 1999. The role of the L4 33K gene in adenovirus infection. *Virology* 263: 507-516.

Finnen RL, Biddle JF, Flint J. 2001. Truncation of the human adenovirus type 5 L4 33-kDa protein: evidence for an essential role of the carboxy-terminus in the viral infectious cycle. *Virology* 289: 388-399.

Freimuth P. 1996. A human cell line selected for resistance to adenovirus infection has reduced levels of the virus receptor. *Journal of Virology* 70: 4081-4085.

Gaden F, Franqueville L, Magnusson MK, Hong SS, Merten MD, Lindholm L, Boulanger P. 2004. Gene transduction and cell entry pathway of fiber-modified adenovirus type 5 vectors carrying novel endocytic peptide ligands selected on human tracheal glandular cells. *Journal of Virology* 78: 7227-7247.

Gall J, Kass-Eisler A, Leinwand L, Falck-Pedersen E. 1996. Adenovirus type 5 and 7 capsid chimera: fiber replacement alters receptor tropism without affecting primary immune neutralization epitopes. *Journal of Virology* 70: 2116-2123.

Garwes DJ, Xuan H. 1989. Genome typing of three serotypes of porcine adenovirus. *Intervirology* 30: 234-236.

Glasgow JN, Kashentseva E, Dmitriev IP, Curiel, DT. 2005. Adenovirus Polypeptide IIIa as a Novel Locale for Incorporation of Heterologous Peptides. (Abstract presented) American Society of Gene Therapy's 8th Annual Meeting.

Gorziglia MI, Lapcevich C, Roy S, Kang Q, Kadan M, Wu V, Pechan P, Kaleko M. 1999. Generation of an adenovirus vector lacking E1, E2a, E3, and all of E4 except open reading frame 3. *Journal of Virology* 73: 6048-6055.

Graham FL, Smiley J, Russell WC, Nairn R. 1977. Characteristics of a human cell line transformed by DNA from human adenovirus type 5. *Journal of General Virology* 36: 59-74.

Greber UF, Fornerod M. 2005. Nuclear import in viral infections. *Current Topics in Microbiology and Immunology*. 285: 109-138.

Haig DA, Clarke MC, Pereira MS. 1964. Isolation of Adenovirus from a Pig. *Journal of Comparative Pathology*, 74: 81-84

Hammond JM, Jansen ES, Morrissy CJ, van der Heide B, Goff WV, Williamson MM, Hooper PT, Babiuk LA, Tikoo SK, Johnson MA. 2001. Vaccination of pigs with a recombinant porcine adenovirus expressing the gD gene from pseudorabies virus. *Vaccine* 19: 3752-3758.

Hammond JM, Johnson MA. 2005. Porcine adenovirus as a delivery system for swine vaccines and immunotherapeutics. *The Veterinary Journal* 169: 17-27.

Hayes BW, Telling GC, Myat MM, Williams JF, Flint SJ. 1990. The adenovirus L4 100-kilodalton protein is necessary for efficient translation of viral late mRNA species. *Journal of Virology* 64: 2732-2742.

Hemmi S, Geertsen R, Mezzacasa A, Peter I, Dummer R. 1998. The presence of human coxsackievirus and adenovirus receptor is associated with efficient adenovirus-mediated transgene expression in human melanoma cell cultures. *Human Gene Therapy* 9: 2363-2373.

Hirahara T, Yasuhara H, Matsui O, Yamanaka M, Tanaka M, Fukuyama S, Izumida A, Yoshiki K, Kodama K, Nakai M, et al. 1990. Isolation of porcine adenovirus from the respiratory tract of pigs in Japan. *Nippon Juigaku Zasshi*. 52:407-409.

Hoffmann D, Jogler C, Wildner O. 2005. Effects of the Ad5 upstream E1 region and gene products on heterologous promoters. *Journal of Gene Medicine* 10: 1356-1366.

Hoffman P, Rajakumar P, Hoffman B, Heuertz R, Wold WS, Carlin CR. 1992. Evidence for intracellular down-regulation of the epidermal growth factor (EGF) receptor during adenovirus infection by an EGF-independent mechanism. *Journal of Virology* 66: 197-203.

Hoffman P, Yaffe MB, Hoffman BL, Yei S, Wold WS, Carlin C. 1992. Characterization of the adenovirus E3 protein that down-regulates the epidermal growth factor receptor. Evidence for intermolecular disulfide bonding and plasma membrane localization. *Journal of Biological Chemistry* 267: 13480-13487.

Honkavuori KS, Pollard BD, Rodriguez MS, Hay RT, Kemp GD 2004. Dual role of the adenovirus pVI C terminus as a nuclear localization signal and activator of the viral protease. *Journal of General Virology* 85: 3367-3376.

Hong SS, Karayan L, Tournier J, Curiel DT, Boulanger PA. 1997. Adenovirus type 5 fiber knob binds to MHC class I alpha2 domain at the surface of human epithelial and B lymphoblastoid cells. *The EMBO Journal* 16: 2294-2306.

Hong SS, Szolajska E, Schoehn G, Franqueville L, Myhre S, Lindholm L, Ruigrok RW, Boulanger P, Chroboczek J. 2005. The 100K-chaperone protein from adenovirus serotype 2 (Subgroup C) assists in trimerization and nuclear localization of hexons from subgroups C and B adenoviruses. *Journal of Molecular Biology* 352: 125-136.

Horwitz MS. 2004. Function of adenovirus E3 proteins and their interactions with immunoregulatory cell proteins. *The Journal of Gene Medicine* 6: S172-S183.

Joung I, Harber G, Gerecke KM, Carroll SL, Collawn JF, Engler JA. 2005. Improved gene delivery into neuroglial cells using a fiber-modified adenovirus vector. *Biochemical and Biophysical research Communications* 328: 1182-1187.

Kadoi K, Inoue Y, Ikeda T, Kamata H, Yukawa M, Iwabuchi M, Inaba Y. 1995. Isolation of porcine adenovirus as a candidate of 5th serotype. *Journal of Basic Microbiology* 35: 195-204.

Kadoi K, Iwabuchi M, Satoh T, Katase T, Kawaji T, Morichi T. 1997. Adenovirus isolation from spleen lymphocytes of apparently healthy pigs. *New Microbiologica* 20: 215-220.

Kasamatsu H, and Nakanishi A. 1998. How do animal DNA viruses get to the nucleus? *Ann Rev Microbiol.* 52: 627-686.

Kirby I, Davison E, Beavil AJ, Soh CP, Wickham TJ, Roelvink PW, Kovesdi I, Sutton BJ, Santis G. 1999. Mutations in the DG loop of adenovirus type 5 fiber knob protein abolish high-affinity binding to its cellular receptor CAR. *Journal of Virology* 73: 9508-9514.

Kirby I, Davison E, Beavil AJ, Soh CP, Wickham TJ, Roelvink PW, Kovesdi I, Sutton BJ, Santis G. 2000. Identification of contact residues and definition of the CAR-binding site of adenovirus type 5 fiber protein. *Journal of Virology* 74: 2804-2813.

Kitajewski J, Schneider RJ, Safer B, Munemitsu SM, Samuel CE, Thimmappaya B, Shenk T. 1986. Adenovirus VAI RNA antagonizes the antiviral action of interferon by preventing activation of the interferon-induced eIF-2 alpha kinase. *Cell* 45: 195-200.

Knipe DM, and Howley PM. 2001. *Viruses and Their Replication.* (p. 2265) *Fields Virology.* Volume 2, 4th Edition. Lippincott, Williams and Wilkins. Philadelphia, PA.

Koizumi N, Mizuguchi H, Kondoh M, Fujii M, Hayakawa T, Watanabe Y. 2004. Efficient gene transfer into human trophoblast cells with adenovirus vector containing chimeric type 5 and 35 fiber protein. *Biol. Pharm. Bull.* 27: 2046-2048.

Korokhov N, Mikheeva G, Krendelshchikov A, Belousova N, Simonenko V, Krendelshchikova V, Pereboev A, Kotov A, Kotova O, Triozzi PL, Aldrich WA, Douglas JT, Lo KM, Banerjee PT, Gillies SD, Curiel DT, Krasnykh V. 2003. Targeting of adenovirus via genetic modification of the viral capsid combined with a protein bridge. *Journal of Virology* 77: 12931-12940.

Kovacs GM, Harrach B, Zakhartchouk AN, Davison AJ. 2005. Complete genome sequence of simian adenovirus 1: an Old World monkey adenovirus with two fiber genes. *Journal of General Virology* 86: 1681-1686.

Krasnykh VN, Dmitriev I, Mikheeva G, Miller CR, Belousova N, Curiel DT. 1998. Characterization of an adenovirus vector containing a heterologous peptide epitope in the HI loop of the fiber knob. *Journal of Virology* 72: 1844-1852.

Krasnykh VN, Mikheeva GV, Douglas JT, Curiel DT. 1996. Generation of recombinant adenovirus vectors with modified fibers for altering viral tropism. *Journal of Virology* 70: 6839-6846.

Kreppel F, Kochanek S. 2004. Long-term transgene expression in proliferating cells mediated by episomally maintained high-capacity adenovirus vectors. *Journal of Virology* 78: 9-22.

Kulshreshtha V, Babiuk LA, Tikoo SK. 2004. Role of bovine adenovirus-3 33K protein in viral replication. *Virology* 323: 59-69.

Lee J, Lee HJ, Shin MK, Ryu WS. 2004. Versatile PCR-mediated insertion or deletion mutagenesis *BioTechniques* 36: 398-400.

Lee TW, Blair GE, Matthews DA. 2003. Adenovirus core protein VII contains distinct sequences that mediate targeting to the nucleus and nucleolus, and colocalization with human chromosomes. *Journal of General Virology* 84: 3423-3428.

Legrand V, Spehner D, Schlesinger Y, Settelen N, Pavirani A, Mehtali M. 1999. Fiberless recombinant adenoviruses: virus maturation and infectivity in the absence of fiber. *Journal of Virology* 73: 907-919.

Leopold PL, Ferris B, Grinberg I, Worgall S, Hackett NR, Crystal RG. 1998. Fluorescent virions: dynamic tracking of the pathway of adenoviral gene transfer vectors in living cells. *Human Gene therapy* 9: 367-378.

Li X, Babiuk LA, Tikoo SK. 2004. Analysis of early region 4 of porcine adenovirus type 3. *Virus Research* 104: 181-190.

Li Y, Pong RC, Bergelson JM, Hall MC, Sagalowsky AI, Tseng CP, Wang Z, Hsieh JT. 1999. Loss of adenoviral receptor expression in human bladder cancer cells: a potential impact on the efficacy of gene therapy. *Cancer Research* 59: 325-330.

Liebermann H, Mentel R, Bauer U, Pring-Akerblom P, Dolling R, Modrow S, Seidel W. 1998. Receptor binding sites and antigenic epitopes on the fiber knob of human adenovirus serotype 3. *Journal of Virology* 72: 9121.

Lusky M, Christ M, Rittner K, Dieterle A, Dreyer D, Mourot B, Schultz H, Stoeckel F, Pavirani A, Mehtali M. 1998. In vitro and in vivo biology of recombinant adenovirus vectors with E1, E1/E2A, or E1/E4 deleted. *Journal of Virology* 72: 2022-2032.

- Lutz P, Kedinger C. 1996. Properties of the adenovirus IVa2 gene product, an effector of late-phase-dependent activation of the major late promoter. *Journal of Virology* 70:1396-1405.
- Lutz P, Rosa-Calatrava M, Kedinger C. 1997. The product of the adenovirus intermediate gene IX is a transcriptional activator. *Journal of Virology* 71:5102-5109.
- Macara, IG. 2001. Transport into and out of the nucleus. *Microbiology and Molecular Biology Reviews*. 65: 570-594.
- Madison DL, Yaciuk P, Kwok RP, Lundblad JR. 2002. Acetylation of the adenovirus-transforming protein E1A determines nuclear localization by disrupting association with importin-alpha. *The Journal of Biological Chemistry* 277: 38755-38763.
- Maluquer de Motes C, Clemente-Casares P, Hundesa A, Martin M, Girones R. 2004. Detection of bovine and porcine adenoviruses for tracing the source of fecal contamination. *Applied and Environmental Microbiology* 70: 1448-1454.
- Marttila M, Persson D, Gustafsson D, Liszewski MK, Atkinson JP, Wadell G, Arnberg N. 2005. CD46 is a cellular receptor for all species B adenoviruses except types 3 and 7. *Journal of Virology* 79: 14429-14436.
- Matthews DA. 2001. Adenovirus protein V induces redistribution of nucleolin and B23 from nucleolus to cytoplasm. *Journal of Virology* 75: 1031-1038.
- Mei YF, Skog J, Lindman K, Wadell G. 2003. Comparative analysis of the genome organization of human adenovirus 11, a member of the human adenovirus species B, and the commonly used human adenovirus 5 vector, a member of species C. *Journal of General Virology* 84: 2061-2072.
- Miller CR, Buchsbaum DJ, Reynolds PN, Douglas JT, Gillespie GY, Mayo MS, Raben D, Curiel DT. 1998. Differential susceptibility of primary and established human glioma cells to adenovirus infection: targeting via the epidermal growth factor receptor achieves fiber receptor-independent gene transfer. *Cancer Research* 58:5738-5748.
- Mittereder N, March KL, Trapnell BC. 1996. Evaluation of the concentration and bioactivity of adenovirus vectors for gene therapy. *Journal of Virology* 70: 7498-7509.
- Miyazawa N, Crystal RG, Leopold PL. 2001. Adenovirus serotype 7 retention in a late endosomal compartment prior to cytosol escape is modulated by fiber protein. *Journal of Virology* 75: 1387-1400.
- Miyazawa N, Leopold PL, Hackett NR, Ferris B, Worgall S, Falck-Pedersen E, Crystal RG. 1999. Fiber swap between adenovirus subgroups B and C alters intracellular trafficking of adenovirus gene transfer vectors. *Journal of Virology* 73: 6056-6065.

Mizuguchi H, Koizumi N, Hosono T, Utoguchi N, Watanabe Y, Kay MA, Hayakawa T. 2001. A simplified system for constructing recombinant adenoviral vectors containing heterologous peptides in the HI loop of their fiber knob. *Gene Therapy* 8: 730-735.

Molin M, Bouakaz L, Berenjian S, Akusjarvi G. 2002. Unscheduled expression of capsid protein IIIa results in defects in adenovirus major late mRNA and protein expression. *Virus Research* 83:197-206.

Morgan C, Rosenkranz HS, Mednis B. 1969. Structure and development of viruses as observed in the electron microscope. V. Entry and uncoating of adenovirus. *Journal of Virology* 4: 777-796.

Morin N, Boulanger P. Hexon trimerization occurring in an assembly-defective, 100K temperature-sensitive mutant of adenovirus 2. *Virology* 152: 11-31.

Mysiak ME, Holthuisen PE, van der Vliet PC. 2004a. The adenovirus priming protein pTP contributes to the kinetics of initiation of DNA replication. *Nucleic Acids Research* 32: 3913-3920.

Mysiak ME, Wyman C, Holthuisen PE, van der Vliet PC. 2004b. NFI and Oct-1 bend the Ad5 origin in the same direction leading to optimal DNA replication. *Nucleic Acids Research* 32: 6218-6225.

Nagy M, Nagy E, Tuboly T. 2001. The complete nucleotide sequence of porcine adenovirus serotype 5. *Journal of General Virology* 82: 525-529.

Nagy M, Nagy E, Tuboly T. 2002. Sequence analysis of porcine adenovirus serotype 5 fibre gene: evidence for recombination. *Virus Genes* 24: 181-185.

Nakano MY, Boucke K, Suomalainen M, Stidwill RP, Greber UF. 2000. The first step of adenovirus type 2 disassembly occurs at the cell surface, independently of endocytosis and escape to the cytosol. *Journal of Virology* 74: 7085-7095.

Nasimuzzaman M, Kuroda M, Dohno S, Yamamoto T, Iwatsuki K, Matsuzaki S, Mohammad R, Kumita W, Mizuguchi H, Hayakawa T, Nakamura H, Taguchi T, Wakiguchi H, Imai S. 2005. Eradication of epstein-barr virus episome and associated inhibition of infected tumor cell growth by adenovirus vector-mediated transduction of dominant-negative EBNA1. *Molecular Therapy* 11: 578-590.

Nelson M, Silver P. 1989. Context affects nuclear protein localization in *Saccharomyces cerevisiae*. *Molecular Cell Biology* 9: 384-399.

Ostapchuk P, and Hearing P. 2003. Minimal cis-acting elements required for adenovirus genome packaging. *Journal of Virology* 77: 5127-5135.

Ostapchuk P, and Hearing P. 2005. Control of adenovirus packaging. *J Cell Biochem* 96:25-35.

Ophorst OJ, Kostense S, Goudsmit J, De Swart RL, Verhaagh S, Zakhartchouk A, Van Meijer M, Sprangers M, Van Amerongen G, Yuksel S, Osterhaus AD, Havenga MJ. 2004. An adenoviral type 5 vector carrying a type 35 fiber as a vaccine vehicle: DC targeting, cross neutralization, and immunogenicity. *Vaccine* 22: 3035-3044.

Pante N, and Aebi U. 1996. Toward the molecular dissection of protein import into the nuclei. *Curr Opin Cell Biol* 8:397-406.

Parks RJ. 2004. Adenovirus protein IX: a new look at an old protein. *Molecular Therapy* 11:9-25.

Perez-Romero P, Tyler RE, Abend JR, Dus M, Imperiale MJ. 2005. Analysis of the interaction of the adenovirus L1 52/55-kilodalton and IVa2 proteins with the packaging sequence *in vivo* and *in vitro*. *Journal of Virology* 79: 2366-2374.

Pillet S, Annan Z, Fichelson S, Morinet F. 2003. Identification of a nonconventional motif necessary for the nuclear import of the human parvovirus B19 major capsid protein (VP2). *Virology* 306: 25-32.

Rao XM, Tseng MT, Zheng X, Dong Y, Jamshidi-Parsian A, Thompson TC, Brenner MK, McMasters KM, Zhou HS. 2004. E1A-induced apoptosis does not prevent replication of adenoviruses with deletion of E1b in majority of infected cancer cells. *Cancer Gene Therapy* 11:585-593.

Reddy PS, Idamakanti N, Babiuk LA, Mehtali M, Tikoo SK. 1999b. Porcine adenovirus-3 as a helper-dependent expression vector. *Journal of General Virology* 80: 2909-2916.

Reddy PS, Idamakanti N, Derbyshire JB, Nagy E. 1997. Characterization of the early region 4 of porcine adenovirus type 3. *Virus Genes* 15: 87-90.

Reddy PS, Idamakanti N, Hyun BH, Tikoo SK, Babiuk LA. 1999a. Development of porcine adenovirus-3 as an expression vector. *Journal of General Virology* 80: 563-570.

Reddy PS, Idamakanti N, Song JY, Lee JB, Hyun BH, Park JH, Cha SH, Bae YT, Tikoo SK, Babiuk LA. 1998. Nucleotide sequence and transcription map of porcine adenovirus type 3. *Virology* 251: 414-426.

Reddy PS, Nagy E, Derbyshire JB. 1995. Sequence analysis of putative pVIII, E3 and fibre regions of porcine adenovirus type 3. *Virus Research* 36: 97-106.

Rexroad J, Wiethoff CM, Green AP, Kierstead TD, Scott MO, Middaugh CR. 2003. Structural stability of adenovirus type 5. *Journal of Pharmaceutical Sciences* 92: 665-678.

Riley D, Flint SJ. 1993. RNA-binding properties of a translational activator, the adenovirus L4 100-kilodalton protein. *Journal of Virology* 67: 3586-3595.

Roberts BL, Richardson WD, Smith AE. 1987. The effect of protein context on nuclear location signal function. *Cell* 50: 465-475.

Romano G, Michell P, Pacilio C, Giordano A. 2000. Latest developments in gene transfer technology: achievements, perspectives, and controversies over therapeutic applications. *Stem Cells* 18: 19-39.

Rosa-Calatrava M, Grave L, Puvion-Dutilleul F, Chatton B, Keding C. 2001. Functional analysis of adenovirus protein IX identifies domains involved in capsid stability, transcriptional activity, and nuclear reorganization. *Journal of Virology* 75:7131-7141.

Rots MG, Curiel DT, Gerritsen WR, Haisma HJ. 2003. Targeted cancer gene therapy: the flexibility of adenoviral gene therapy vectors. *Journal of Controlled Release* 87: 159-165.

Roy S, Clawson DS, Calcedo R, Lebherz C, Sanmiguel J, Wu D, Wilson JM. 2005. Use of chimeric adenoviral vectors to assess capsid neutralization determinants. *Virology* 333: 207-214.

Russell WC. 2000. Update on adenovirus and its vectors. *Journal of General Virology* 81: 2573-2604.

Sanlioglu S, Benson PK, Yang J, Atkinson EM, Reynolds T, Engelhardt JF. 2000. Endocytosis and nuclear trafficking of adeno-associated virus type 2 are controlled by rac1 and phosphatidylinositol-3 kinase activation. *Journal of Virology* 74: 9184-9196.

Sargent KL, Meulenbroek RA, Parks RJ. 2004. Activation of adenoviral gene expression by protein IX is not required for efficient virus replication. *Journal of Virology* 78: 5032-5037.

Saphire AC, Guan T, Schirmer EC, Nemerow GR, Gerace L. 2000. Nuclear import of adenovirus DNA *in vitro* involves the nuclear protein import pathway and hsc70. *Journal of Biological Chemistry* 275: 4298-4304.

Scheres SH, Marabini R, Lanzavecchia S, Cantele F, Rutten T, Fuller SD, Carazo JM, Burnett RM, San Martin C. 2005. Classification of single-projection reconstructions for cryo-electron microscopy data of icosahedral viruses. *Journal of Structural Biology*. 151:79-91.

Schrenzel M, Oaks JL, Rotstein D, Maalouf G, Snook E, Sandfort C, Rideout B. 2005. Characterization of a new species of adenovirus in falcons. *Journal of Clinical Microbiology* 43: 3402-3413.

Selvarajah S, Puffer B, Pantophlet R, Law M, Doms RW, Burton DR. 2005. Comparing antigenicity and immunogenicity of engineered gp120. *Journal of Virology* 79: 12148-12163.

Singh M, Shmulevitz M, Tikoo SK. 2005. A newly identified interaction between IVa2 and pVIII proteins during porcine adenovirus type 3 infection. *Virology* 336: 60-69.

Sorg G, Stamminger T. 1999. Mapping of nuclear localization signals by simultaneous fusion to green fluorescent protein and to beta-galactosidase. *BioTechniques* 26: 858-862.

Stevenson SC, Rollence M, Marshall-Neff J, McClelland A. 1997. Selective targeting of human cells by a chimeric adenovirus vector containing a modified fiber protein. *Journal of Virology* 71: 4782-4790.

Sumida SM, Truitt DM, Lemckert AA, Vogels R, Custers JH, Addo MM, Lockman S, Peter T, Peyerl FW, Kishko MG, Jackson SS, Gorgone DA, Lifton MA, Essex M, Walker BD, Goudsmit J, Havenga MJ, Barouch DH. 2005. Neutralizing antibodies to adenovirus serotype 5 vaccine vectors are directed primarily against the adenovirus hexon protein. *The Journal of Immunology* 174: 7179-7185.

Suomalainen M, Nakano MY, Keller S, Boucke K, Stidwill RP, Greber UF. 1999. Microtubule-dependent plus- and minus end-directed motilities are competing processes for nuclear targeting of adenovirus. *The Journal of Cell Biology* 144: 657-672.

Teschke CM, McGough A, Thuman-Commike PA. 2003. Penton release from P22 heat-expanded capsids suggests importance of stabilizing penton-hexon interactions during capsid maturation. *Biophysical Journal* 84:2585-2592.

Toth K, Doronin K, Kuppuswamy M, Ward P, Tollefson AE, Wold WS. 2005. Adenovirus immunoregulatory E3 proteins prolong transplants of human cells in immunocompetent mice. *Virus Research* 108: 149-159.

Tuboly T, Nagy E. 2000. Sequence analysis and deletion of porcine adenovirus serotype 5 E3 region. *Virus Research* 68: 109-117.

Tuboly T, Nagy E. 2001. Construction and characterization of recombinant porcine adenovirus serotype 5 expressing the transmissible gastroenteritis virus spike gene. *Journal of General Virology* 82; 183-190.

van der Avoort HG, Wermenbol AG, Zomerdijk TP, Kleijne JA, van Asten JA, Jensma P, Osterhaus AD, Kidd AH, de Jong JC. 1989. Characterization of fastidious adenovirus types 40 and 41 by DNA restriction enzyme analysis and by neutralizing monoclonal antibodies. *Virus Research* 12: 139-157.

van Raaij MJ, Louis N, Chroboczek J, Cusack S. 1999. Structure of the human adenovirus serotype 2 fiber head domain at 1.5 Å resolution. *Virology* 262:333-343.

Vellekamp G, Porter FW, Sutjipto S, Cutler C, Bondoc L, Liu YH, Wylie D, Cannon-Carlson S, Tang JT, Frei A, Voloch M, Zhuang S. 2001. Empty capsids in column-purified recombinant adenovirus preparations. *Human Gene Therapy* 12: 1923-1936.

Vellinga J, Van der Heijdt S, Hoeben RC. 2005. The adenovirus capsid: major progress in minor proteins. *Journal of Gen Virol* 86: 1581-1588.

Voet D and Voet JG. *Biochemistry*. John Wiley & sons, Toronto, 1990. p. 865-866.

Volpers C, Thirion C, Biermann V, Hussmann S, Kewes H, Dunant P, von der Mark H, Herrmann A, Kochanek S, Lochmuller H. 2003. Antibody-mediated targeting of an adenovirus vector modified to contain a synthetic immunoglobulin g-binding domain in the capsid. *Journal of Virology* 77: 2093-2104.

Walters RW, Freimuth P, Moninger TO, Ganske I, Zabner J, Welsh MJ. 2002. Adenovirus fiber disrupts CAR-mediated intercellular adhesion allowing virus escape. *Cell* 110: 789-799.

Wang K, Huang S, Kapoor-Munshi A, Nemerow G. 1998. Adenovirus internalization and infection require dynamin. *Journal of Virology* 72: 3455-3458.

Whittaker GR. 2003. Virus nuclear import. *Advanced Drug Delivery Reviews* 55: 733-747.

Wickham TJ, Tzeng E, Shears LL 2nd, Roelvink PW, Li Y, Lee GM, Brough DE, Lizonova A, Kovesdi I. 1997. Increased *in vitro* and *in vivo* gene transfer by adenovirus vectors containing chimeric fiber proteins. *Journal of Virology* 71: 8221-8229.

Wiethoff CM, Wodrich H, Gerace L, Nemerow GR. 2005. Adenovirus protein VI mediates membrane disruption following capsid disassembly. *Journal of Virology* 79: 1992-2000.

Weitzman MD. 2005. Functions of the adenovirus E4 proteins and their impact on viral vectors. *Frontiers in Bioscience* 10: 1106-1117.

Wohlfart C. 1988. Neutralization of adenoviruses: kinetics, stoichiometry, and mechanisms. *Journal of Virology* 62: 2321-2328.

Wu H, Han T, Belousova N, Krasnykh V, Kashentseva E, Dmitriev I, Kataram M, Mahasreshti PJ, Curiel DT. 2005. Identification of sites in adenovirus hexon for foreign peptide incorporation. *Journal of Virology* 79: 3382-3390.

Wu Q, Tikoo SK. 2004. Altered tropism of recombinant bovine adenovirus type-3 expressing chimeric fiber. *Virus Research* 99:9-15.

- Xia D, Henry LJ, Gerard RD, Deisenhofer J. 1994. Crystal structure of the receptor-binding domain of adenovirus type 5 fiber protein at 1.7 Å resolution. *Structure* 2: 1259-1270.
- Xiao W, Warrington KH Jr, Hearing P, Hughes J, Muzyczka N. 2002. Adenovirus-facilitated nuclear translocation of adeno-associated virus type 2. *Journal of Virology* 76:11505-11517.
- Xing L, Tikoo SK. 2003. Characterization of cis-acting sequences involved in packaging porcine adenovirus type 3. *Virology* 314: 650-661.
- Xing L, Tikoo SK. 2004a. cis-Acting packaging motifs of porcine adenovirus type 3. *Virus Research* 104: 207-214.
- Xing L, Tikoo SK. 2004b. Viral RNAs detected in virions of porcine adenovirus type 3. *Virology* 321: 372-382.
- Xing L, Tikoo SK. 2005. Promoter activity of left inverted terminal repeat and downstream sequences of porcine adenovirus type 3. *Virus Research* 109: 51-58.
- Xue Y, Johnson JS, Ornelles DA, Lieberman J, Engel DA. 2005. Adenovirus protein VII functions throughout early phase and interacts with cellular proteins SET and pp32. *Journal of Virology* 79: 2474-2483.
- Zakhartchouk A, Connors W, van Kessel A, Tikoo SK. 2004. Bovine adenovirus type 3 containing heterologous protein in the C-terminus of minor capsid protein IX. *Virology* 320: 291-300.
- Zakhartchouk A, Zhou Y, Tikoo SK. 2003. A recombinant E1-deleted porcine adenovirus-3 as an expression vector. *Virology* 313: 377-386.
- Zhang L, Gomis S, Tikoo SK. 2005. Evaluation of promoters for foreign gene expression in the E3 region of bovine adenovirus type-3. *Virus Research* 110: 196-176.
- Zhang W, Imperiale MJ. 2000. Interaction of the adenovirus IVa2 protein with viral packaging sequences. *Journal of Virology* 74: 2687-2693.
- Zhang W, Imperiale MJ. 2003. Requirement of the adenovirus IVa2 protein for virus assembly. *Journal of Virology* 77: 3586-3594.
- Zhang W, Low JA, Christensen JB, Imperiale MJ. 2001. Role for the adenovirus IVa2 protein in packaging of viral DNA. *Journal of Virology* 75: 10446-10454.
- Zhang Y. 2005. Adenovirus Receptors. *Journal of Virology* 79: 12125-12131.

Zhou Y, Pyne C, Tikoo SK. 2001. Determination of bovine adenovirus-3 titer based on immunohistochemical detection of DNA binding protein in infected cells. *Journal of Virological Methods* 94: 147-153.

Zhou Y, Tikoo SK. 2001. Analysis of early region 1 of porcine adenovirus type 3. *Virology* 291: 68-76.

Zhu J, Qiu Z, Wiese C, Isheii Y, Fredrichsen J, Rajashekara G, and Splitter GA. 2005. Nuclear and mitochondrial localization signals overlap within bovine herpesvirus 1 tegument protein VP22. *Journal of Biological Chemistry* 280: 16038-16044