

---

---

# Investigations into the Dehulling of Pigeon Peas and Mung Beans

A. Opoku<sup>1</sup>, L. Tabil<sup>1</sup>, W.J. Crerar<sup>1</sup> and S.J. Park<sup>2</sup>

<sup>1</sup>Department of Agricultural and Bioresource Engineering  
University of Saskatchewan  
57 Campus Drive  
Saskatoon, Sk S7N 5A9

<sup>2</sup>Agriculture and Agri-Food Canada  
Research Station  
Harrow, ON N0R 1G0

---

---

## Abstract

Legumes provide a rich source of protein for animal and human consumption. They also supply a substantial amount of minerals and vitamins. Currently the world production of legumes is estimated to be 57.5 million metric tonnes. After harvest, pigeon peas (*Cajanus cajan* L.) and mung beans (*Vigna radiata* L.) are dehulled to improve cooking and nutritional qualities and to reduce cooking time. Pigeon peas and mung beans can be consumed as dehulled splits, whole, canned, boiled, roasted or ground into flour to make a variety of desserts, snacks and main dishes. These legumes are hard to dehull because of the presence of mucilages and gums which form a strong bond between the hulls and the cotyledons. To improve the dehulling characteristics of these legumes, a tangential abrasive dehulling device (TADD) was used to investigate their dehulling characteristics. Different treatments consisting of heating, soaking and heating, steaming and drying in addition to tempering were investigated. The control samples yielded less dehulled kernels and generated more fines for both pigeon peas and mung beans. Steaming at 98.0°C for 10 min and heating at 120°C for 10 min followed by tempering for 24 h yielded more dehulled kernels for both pigeon peas and mung beans compared to the other treatments.

## Introduction

Legumes provide a rich source of protein for animal and human consumption. They also supply a substantial amount of minerals and vitamins. Currently the world production of legumes is estimated to be 57.5 million metric tonnes. After harvest, pigeon peas (*Cajanus cajan* L.) and mung beans (*Vigna radiata* L.) are dehulled to improve cooking and nutritional qualities and to reduce cooking time. Pigeon peas and mung beans can be consumed as dehulled splits, whole, canned, boiled, roasted or ground into

flour to make a variety of desserts, snacks and main dishes. These legumes are hard to dehull because of the presence of mucilages and gums which form a strong bond between the hulls and the cotyledons. Ramakrishnaiah and Kurien (1985) reported that pigeon pea grains of poor dehulling characteristic contained higher contents of uronic acid. The variability in dehulling characteristics of legume grains may be affected by the grain genotypes and their physical characteristics (Ramakrishnaian and Kurien 1983; Ehiwe and Reichert 1987; Singh et al. 1992)

To diversify the Canadian agricultural production, increased efforts have been placed on breeding pulses, including mung beans and pigeon peas, which are adapted to the climatic and soil conditions in Canada. Dehulling quality of mung beans and pigeon peas is certainly one of the primary concerns which are considered by breeders. Legumes with good dehulling characteristics are required by processors to satisfy both domestic and the export markets. Cultivars that are easy to dehull coupled with high dhal yield recovery may be required by processors.

The grain kernels are usually preconditioned to loosen the hulls from the cotyledons before they can be separated using mechanical means. Preconditioning methods to loosen the husk may involve heat treatment alone or soaking in water or chemical solution for a period of time, together with heat treatment to be followed by hot dehulling or tempering before dehulling (Ramakrishnaiah and Kurien 1983; Srivastava et al. 1988; Phirke et al. 1992; Phirke and Bhole 2000). The effect of steam preconditioning on the physical and dehulling characteristics of locust bean was also investigated by Adewumi and Igbeka (1993). Kernel preconditioning is generally designed to toughen the hull and loosen the gummy bond between the hull and the cotyledon and to harden the cotyledon to reduce damage.

## **Objectives**

The main objective of this investigation is to identify and test different preconditioning treatments on dehulling pigeon peas and mung beans. Specifically, the following treatments were studied:

1. Heating and tempering,
2. Water and chemical soaking followed by heating and tempering, and
3. Steaming followed by heating and tempering.

## **Materials and Methods**

### **Legume grain samples**

Mung bean and pigeon pea samples were supplied by Agriculture and Agri-Food Canada Research Station, Harrow, ON. The samples were placed in polyethylene bags and stored in an air-tight Coleman® rubber container at room temperature. The samples were manually cleaned before the experiments. Sound and intact mung bean and pigeon pea samples were used in the dehulling tests.

### **Tangential Abrasive Dehulling Device (TADD)**

Figure 1 shows the commercial production model of the tangential abrasive dehulling device (TADD) (Reichert et al. 1986) used to dehull the mung bean and pigeon pea samples. The TADD was manufactured by Venables Machine Works Limited,

Saskatoon, Saskatchewan as model 4E-230. The TADD consists of a horizontally rotating abrasive disk, a stationary head plate holds eight stainless steel open-bottomed sample cups which are mounted vertically over the rotating disk. A cover plate with a rubberized material attached to it is used to cover the cups when the machine is in operation. Shims are used to adjust the clearance between the rotating disk and sample cups to allow a fan to blow the hulls, broken particles and fines into a cyclone and a receptacle attached to the dehuller. A digital electronic timer (Model 8683-10, Cole-Parmer Instrument Company, Chicago, IL) automatically controls the residence time during a test. A spring-operated solenoid rubs on two “O” rings on the shaft mount and they act as a brake when the current supplied to the motor is terminated. A test is run by placing the samples into the sample cups and running the machine for a specified duration. After the test, the abraded materials in the sample cups are removed by a vacuum aspirating collector described by Oomah et al (1981).

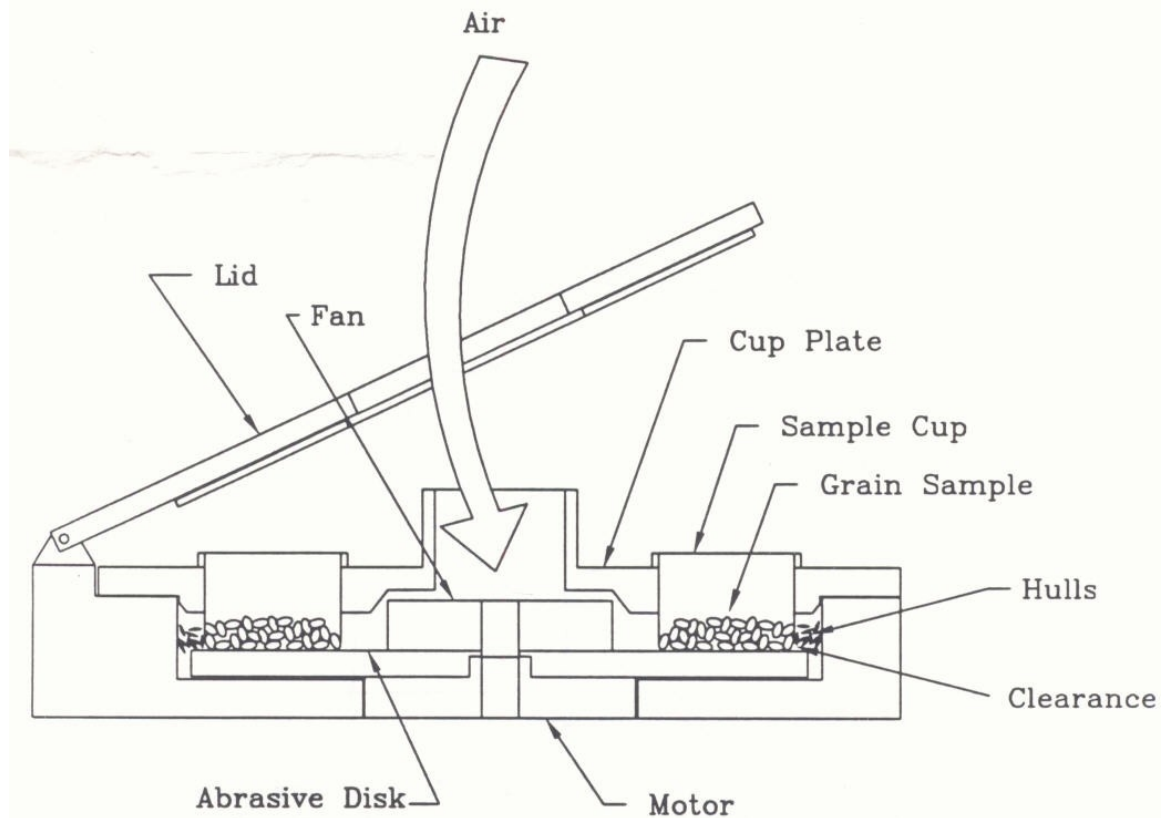

Figure 1. Schematic diagram of the tangential abrasive dehulling device (TADD).

### Grit Size Selection

To determine the appropriate grit size for dehulling mung beans and pigeon peas, grit sizes 24, 36 and 50 were tested. Untreated samples, with moisture contents about 10% wet basis (wb) were used in the tests. The samples were dehulled for 60 s and the abraded materials were separated into hulls, whole dehulled, split dehulled, unde-hulled (whole and split) and fines. The 36 grit size was selected and was used for the rest of the experiments.

### Preconditioning Methods

Different methods were used to precondition pigeon pea and mung bean samples. The preconditioning methods consisted of: a) heating and tempering, b) soaking in water or chemical solution, heating and tempering and c) steaming, heating and tempering. Table 1 lists the preconditioning treatments used in the experiments. The pigeon pea and the mung bean samples were heated in a fluidized bed dryer (Model 23850, Lab-Line Instruments Inc., Melrose Park, IL). They were soaked in distilled water or 8% urea solution using wide mouth jars. They were steamed in a laboratory steam conditioner. The soaking was done at room temperature (19 to 24°C).

Table 1. Preconditioning treatment methods used in the experiments

Treatments	Description
Treatment A	Heated at 120°C for 6 min, and
Heating and tempering	A1. No tempering A2. Tempered for 4 h A3. Tempered for 24 h
Treatment B	Soaked for 4 h at room temperature, and
Water soaking, heating and tempering	B1. Heated at 120°C for 6 min and tempered for 4 h B2. Heated at 120°C for 10 min and tempered for 4 h B3. Heated at 120°C for 10 min and tempered for 24 h
Treatment C	Soaked for 4 h and heated at 120°C for 10 min, and
8% urea solution soaking, heating and tempering	C1. No tempering C2. Tempered for 4 h C3. Tempered for 24 h
Treatment D	Steamed at 98.0°C for 10 min and heated at 120°C for 10 min, and
Steaming, heating and tempering	D1. No tempering D2. Tempered for 4 h D3. Tempered for 24 h
Control	No treatment, material at room temperature

### Sample Dehulling and Separation

After preconditioning, two samples of about 20.0 g each were placed in the two of sample cups of the TADD. A total of about 40.0 g was used for each dehulling test. The samples were dehulled for 60 s. The tests were duplicated. The abraded samples were removed from the cups using a vacuum aspirating device. They were then manually separated into hulls, whole dehulled, split dehulled and undeulled (split and whole). A kernel was considered completely dehulled when there was no hull adhering to it. Hulls, fines and split dehulled and undeulled (split) that were blown into the receptacle attached to the TADD were also collected and separated. The material collected in the receptacle was first separated using a stack of sieves, consisting of sieve numbers 14 (1.41 mm), 16 (1.19 mm), 18 (1.00 mm), 20 (850 µm) and pan. Each fraction on top of

each sieve was then separated using a fractionating aspirator (Style No. CFZ1, Carter-Day Company, Minneapolis, MN). The separated fractions in the fractionating aspirator were then manually separated. The hulls, split dehulled and unde-hulled were added to earlier manually separated fractions and weighed. The fraction in the pan was considered as fines and it was also weighed.

### Manual Dehulling

About 30.0 g sample each of pigeon peas and mung beans were soaked in distilled water and the seed coat was removed manually. The seed coat and the cotyledons were dried at 71.1°C (160°F) for 2 nights and they were weighed. The test was duplicated.

### Moisture content

The moisture contents of the samples were determined using the AACC Method 44 – 15A (1995). The one-stage procedure was used for samples with moisture contents less than 13% and the two-stage procedure was used for samples containing moisture contents of 13% or higher. A 2– to 3-g portion of a ground sample was weighed and transferred into 2 or 3 dishes, and the dishes were covered with lids immediately. The dishes were uncovered and placed in an oven at a temperature of 130±1°C for 60 min. The initial moisture contents of the samples were determined for each treatment. Moisture contents after soaking, steaming and heating were determined.

### Data Analysis

A percentage by mass (% w/w) of each separated fraction after dehulling was determined by using equation (1) given as:

$$\% \text{Mass} = 100 * \frac{m_{sf}}{m_i} \quad (1)$$

where:

$m_{sf}$  = mass of each separated fraction after dehulling, and

$m_i$  = initial mass of the samples before dehulling.

A dehulling index,  $\eta$ , was calculated using equation (2) defined as:

$$\eta = \frac{(m_c + m_h) - (m_{uh} + m_f)}{m_i} \quad (2)$$

where:

$m_c$  = mass of dehulled split and whole cotyledons,

$m_h$  = mass of hulls removed,

$m_{uh}$  = mass of unde-hulled kernels, and

$m_f$  = mass of fines in final product.

The dehulling index may vary from a maximum of +1 to a minimum of -1. A maximum of +1 indicates that the entire original grain sample is completely dehulled into two fractions of cotyledons ( $m_c$ ) and hulls ( $m_h$ ) with no fines and unde-hulled grains. A minimum of -1 indicates that the dehulling is not complete, thus the grains have split into fines ( $m_f$ ) and /or not at all dehulled ( $m_{uh}$ ) (Ikebudu et al. 2000).

### Results and Discussion

### Pigeon peas

Table 2 shows the yield fractions of whole dehulled kernels, split dehulled kernels, unde-hulled kernels (whole and split), hulls and fines, for the various preconditioning treatments used for the pigeon pea grains. Also shown in Table 2 are the dehulling indices and the moisture contents of the samples at the time of dehulling. For heating and tempering treatment (treatment A), the highest dehulled fraction (47.3% whole and split kernels) was obtained when the sample was tempered for 4 h (treatment A2). The moisture content was low, and less fines (5.7%) were generated for this treatment. Treatments A2 and A3 produced the same amount of hulls and the amounts of unde-hulled kernels were high when no tempering was done. A high dehulling index of 0.19 was obtained for treatment A2.

Table 2. Average dehulling results for pigeon pea grains.

Treatment	Whole Dehulled kernels (%)	Split dehulled kernels (%)	Undehulled kernels (%)	Hulls (%)	Fines (%)	Dehulling index	Moisture content at dehulling (%, w.b.)
A1	15.7	2.1	63.5	7.4	8.8	-0.47	7.40
A2	43.5	3.8	33.2	10.7	5.7	0.19	7.10
A3	41.6	5.0	33.9	10.7	6.1	0.17	7.57
B1	24.6	2.3	57.1	7.9	3.4	-0.26	21.39
B2	43.0	4.4	33.3	10.3	5.1	0.19	11.19
B3	53.9	2.4	25.0	10.7	4.7	0.37	11.34
C1	14.8	0.8	69.0	6.6	6.2	-0.53	12.77
C2	40.5	1.2	41.4	9.3	4.9	0.05	13.58
C3	45.4	1.5	36.0	9.7	4.3	0.16	11.38
D1	29.5	2.0	49.6	9.1	7.5	-0.17	9.30
D2	54.2	3.2	22.8	11.0	5.7	0.40	8.39
D3	62.5	4.3	13.0	11.3	5.5	0.60	9.07
Control	5.0	1.0	73.7	4.6	11.1	-0.74	10.53

A higher amount of pigeon pea dehulled kernels was produced by the distilled water soaking, heating and tempering treatment compared to the 8% urea soaking, heating and tempering. Lesser fines and lesser amounts of hulls were produced by the urea soaking treatments C2 and C3 compared to the water soaking treatments B2 and B3. Higher amounts of undehulled kernels were obtained for the urea soaking treatment compared to the water soaking treatment. Treatment B1 had the highest moisture content (21.39% wb) at the time of dehulling. The dehulling indices were higher for the distilled water soaking treatments compared to the urea soaking treatments.

Higher amounts of dehulled kernels and hulls were produced when the samples were steamed, heated and tempered for 24 h compared to tempering for 4 h and no tempering. Lesser fines were generated for treatment D3 compared to treatments D1 and D2. Treatment D1 (no tempering) yielded the highest undehulled kernels (49.6%) with the highest moisture content of 9.30% w.b. The dehulling index was lower for treatment D1 (-0.17) compared to D3 (0.60).

The control treatment yielded the lowest dehulled pigeon pea kernels (6.0%) compared to the other preconditioning treatments. It produced the highest amount of undehulled kernels and also the highest amount of fines. The amount of hulls produced was lower than the other treatments since the amount of undehulled kernels was higher. The lowest dehulling index was obtained for this control treatment. A manual method of dehulling yielded 15% hulls and 85% percent dehulled kernels at 13.98% moisture content. All the preconditioning treatments yielded more whole dehulled kernels compared to split dehulled kernels.

### **Mung beans**

The effects of preconditioning treatments on mung beans are presented in Table 3. Treatment A1 yielded higher dehulled kernels (49.9%) with lesser hulls (4.5%) and fines (14.0%), at lower moisture content (7.31% w.b.) compared to treatments A2 and A3. Treatment A2 produced a higher undehulled kernels (46.8%) compared to treatments A1 and A3. Treatment A1 yielded a higher dehulling index of 0.14 compared to treatments A2 and A3.

Tempering did not influence the mung bean samples compared to the pigeon pea samples during the heating and tempering treatments. During dehulling the cotyledons of the mung beans tended to split more than the cotyledons of the pigeon peas. This probably indicates that pigeon pea cotyledons have a stronger bond between them than the mung bean cotyledons.

Water soaking, heating and tempering (B2 and B3) yielded higher dehulled kernels compared to urea soaking, heating and tempering (C2 and C3). Treatment C1 produced a higher amount of undehulled kernels (59.4%). Lower amounts of hulls were produced by treatments B2 and B3 compared to C2 and C3. The amount of fines generated ranged from 13.1 to 13.9% for the water soaking and urea soaking treatments and also the moisture contents at the time of dehulling ranged from 8.26 to 10.59% wb. The dehulling index was high when the grains were soaked in water, heated and tempered for 24 h.

For the steam preconditioning, treatment D3 yielded a higher amount of dehulled mung bean kernels of 68.6% compared to treatments D1 and D2. A higher amount of undehulled kernels was produced by treatment D1 compared to D2 and D3. Treatment

D3 produced a higher amount of hulls with lesser fines compared to treatments D1 and D2. The moisture contents of the mung bean grains at the time dehulling ranged from 6.77 to 8.26% .w.b., with treatment D2 having the lowest moisture content.

The control treatment yielded the lowest dehulled mung bean kernels (9.2%) compared to the other preconditioning treatments. Treatment C1 (59.4%) produced a higher amount of unde-hulled kernels compared to the control treatment (57.4%). The control treatment generated the highest amount of fines (21.9%). The amount of hulls produced was lower than the other treatments since the amount of unde-hulled kernels was higher. The lowest dehulling index was obtained for this control treatment. A manual method of dehulling yielded 9.1% hulls and 90.9% percent dehulled kernels at 12.28% moisture content. All the preconditioning treatments yielded more split dehulled kernels compared to whole dehulled kernels.

Tables 2 and 3 show that steaming at 98.0°C for 10 min and heating at 120°C for 10 min followed by tempering for 24 h yielded the highest dehulled kernels for both pigeon peas and mung beans compared to the other treatments. Further studies are being conducted to determine whether tempering for 8 and 12 h will achieve a comparable amount of dehulled kernels to tempering for 24 h. Also, experiments are being conducted to determine the effect on sodium bicarbonate (NaHCO<sub>3</sub>) on the dehulling characteristics of mung beans and pigeon peas.

Table 3. Average ehulling results for mung bean grains.

Treatment	Whole Dehulled kernels (%)	Split dehulled kernels (%)	Undehulled kernels (%)	Hulls (%)	Fines (%)	Dehulling index	Moisture content at dehulling (%, w.b.)
A1	0.1	49.8	26.7	4.5	14.0	0.14	7.31
A2	0.3	28.8	46.8	4.8	15.0	-0.28	8.47
A3	0.3	44.8	29.7	5.7	15.5	0.06	8.67
B1	0.2	25.6	51.7	4.8	13.6	-0.35	10.59
B2	0.2	35.0	41.1	4.9	13.1	-0.14	8.26
B3	0.5	41.7	33.1	5.5	13.3	0.01	9.60
C1	0.1	18.9	59.4	4.2	13.9	-0.50	9.37
C2	0.3	34.9	42.0	5.3	13.7	-0.15	9.23
C3	0.2	38.6	38.0	5.6	13.9	-0.08	9.38
D1	0.4	44.0	32.5	5.6	13.5	0.04	8.26



Treatment	Whole Dehulled kernels (%)	Split dehulled kernels (%)	Undehulled kernels (%)	Hulls (%)	Fines (%)	Dehulling index	Moisture content at dehulling (%, w.b.)
D2	0.3	62.1	14.7	6.7	12.9	0.41	6.77
D4	0.5	68.1	8.0	7.0	12.6	0.55	7.18
Control	2.0	7.2	57.4	3.5	21.9	-0.67	10.38

## Conclusions

Based upon our experiments, the following conclusions are offered:

1) Heating the pigeon peas at 120°C and tempering for 4 h yielded total dehulled kernels of 47.3% with less fines (5.7%).

2) Water soaking at room temperature and heating at 120°C for 10 min followed by tempering for 24 h yielded more pigeon pea dehulled kernels (56.3%) than urea soaking (46.9%).

3) Steaming and heating followed by tempering for 24 h yielded more pigeon pea dehulled kernels (66.8%) than no tempering (31.5%).

4) The control treatment produced less dehulled pigeon pea kernels and generated more fines compared to the other treatments.

5) Heating the mung beans at 120°C without tempering yielded a higher amount of dehulled kernels (49.9%) with lesser fines than with tempering.

6) Water soaking, heating and tempering for 24 h yielded more mung bean dehulled kernels (42.2%) than urea soaking (38.8%).

7) Steaming and heating followed by tempering for 24 h yielded a higher amount of mung bean dehulled kernels than no tempering.

8) The control treatment produced the lowest amount of dehulled mung bean kernels and generated more fines than the other treatments

9) Overall, steaming at 98.0°C for 10 min and heating at 120°C for 10 min followed by tempering for 24 h yielded the highest dehulled kernels for both pigeon peas and mung beans compared to the other treatments.

## References

- AACC. 1995. Moisture, air-oven Methods 44 – 15A. Approved Methods of American Association of Cereal Chemists, 9<sup>th</sup> ed. The American Association of Cereal Chemists, St. Paul, MN.
- Adewumi, B.A. and J.C. Igbeka. 1993. The effect of steaming on the physical and dehulling characteristics of locust bean (*Parkia biglobosa*). Tropical Agriculture (Trinidad) 70(3): 380 – 382.

- Ehiwe, A.O.F. and R.D. Reichert. 1987. Variability in dehulling quality of cowpea, pigeon pea, and mung bean cultivars determined with the tangential abrasive dehulling device. *Cereal Chemistry* 64(2): 86 – 90.
- Ikebudu, J.A., S. Sokhansanj, R.T. Tyler, B.J. Milne and N.S. Thakor. 2000. Grain conditioning for dehulling of canola. *Canadian Agricultural Engineering* 42(1): 27-32.
- Oomah, B.D., R.D. Reichert and C.G. Youngs. 1981. A novel, multi-sample, tangential abrasive dehulling device (TADD). *Cereal Chemistry* 58(5): 392 – 395.
- Phirke, P.S., S. Pumbarkar and A.B. Tapre. 1992. Evaluation of chemical pre-treatment of pigeonpea grains for milling. *Indian Journal of Agricultural Engineering* 2(2): 141 – 142.
- Phirke, P.S. and N.G. Bhole. 2000. Pretreatment of pigeonpea grain for improvement of dehulling characteristics. *International Journal of Food Science and Technology* 35: 305 – 313.
- Ramakrishnaiah, N. and P. P. Kurien. 1983. Variabilities in the dehulling characteristics of pigeon pea (*Cajanus cajan* L.) cultivars. *Journal of Food Science and Technology* 20: 287 – 291.
- Ramakrishnaiah, N. and P. P. Kurien. 1985. Non-starchy polysaccharides of pigeon pea and their influence on dehulling characteristics. *Journal of Food Science and Technology* 22: 429 – 430.
- Reichert, R.D., R.T. Tyler, A.E. York, D.J. Schwab, J.E. Tatarynovich and M.A. Mwassar. 1986. Description of a production model of the tangential abrasive dehulling device and its application to breeders' samples. *Cereal Chemistry* 63(3): 201 – 207.
- Singh, U., B.A.S. Santosa and P.V. Rao. 1992. Effect of dehulling methods and physical characteristics of grains on dhal yield of pigeonpea (*Cajanus cajan* L.) genotypes. *Journal of Food Science and Technology* 29(6): 350 – 353.
- Srivastava, V., D.P. Mishra, L. Chand, R.K. Gupta and B.P.N. Singh. 1988. Influence of soaking on various biochemical changes and dehusking efficiency in pigeon pea (*Cajanus cajan* L.) seeds. *Journal of Food Science and Technology* 25(5): 267 – 271.