

**STUDIES ON TRITERPENE SAPONINS FROM *Saponaria vaccaria*
SEED AND THEIR APOPTOSIS-INDUCING EFFECT ON
HUMAN CANCER CELL LINES**

A Thesis Submitted to the College of

Graduate Studies and Research

in Partial Fulfillment of the Requirements

for the Degree of Doctor of Philosophy

in the Department of Pharmacology

University of Saskatchewan

Saskatoon

By

Irving Javier Ramirez-Erosa

© Copyright Irving J. Ramirez-Erosa, March 2008. All rights reserved.

The University of Saskatchewan claims copyright in conjunction with the author. Use shall not be made of the material contained herein without proper acknowledgement.

PERMISSION TO USE

In presenting this dissertation in partial fulfillment of the requirements for a Postgraduate degree from the University of Saskatchewan, I agree that the Libraries of this University may make it freely available for inspection. I further agree that permission for copying of this dissertation in any manner, in whole or in part, for scholarly purposes may be granted by the professor or professors who supervised my dissertation work or, in their absence, by the Head of the Department or the Dean of the College in which my thesis work was done. It is understood that any copying or publication or use of this dissertation or parts thereof for financial gain shall not be allowed without my written permission. It is also understood that due recognition shall be given to me and to the University of Saskatchewan in any scholarly use which may be made of any material in my dissertation.

DISCLAIMER

Reference in this dissertation to any specific commercial products, process, or service by trade name, trademark, manufacturer, or otherwise, does not constitute or imply its endorsement, recommendation, or favoring by the University of Saskatchewan. The views and opinions of the author expressed herein do not state or reflect those of the University of Saskatchewan, and shall not be used for advertising or product endorsement purposes.

Requests for permission to copy or to make other uses of materials in this dissertation in whole or part should be addressed to:

Head of the Department of Pharmacology
University of Saskatchewan
A120 Health Sciences Building
107 Wiggins Road
Saskatoon, Saskatchewan S7N 5E5
Canada

OR

Dean
College of Graduate Studies and Research
University of Saskatchewan
107 Administration Place
Saskatoon, Saskatchewan S7N 5A2
Canada

TO GOD

He chose to bring me and my wife
to this university in the middle of the Canadian prairies.
He has used our lives and the lives of others around us to teach us to grow,
to be open, and to learn to walk the line between cultures, deeply enjoying both sides.
All glory and honor to Him.

TO MY DEAR AND EVERLOVING WIFE,
CLAUDIA, AND CHILDREN, ERIC AND DIEGO

This work is for, and because of you and all the generations to come.
It is dedicated to all our journeys in learning to thrive.

TO MY MOTHER LIZBETH

AND

PARENTS IN-LAW ROGER AND FLOR

Thank you for loving us and showing us how to live in
an ever changing world while keeping our values unchanged.

TO ALL MY FAMILY AND FRIENDS

For their invaluable support throughout all these years.

TO THOSE WHO BELIEVE IN THEMSELVES

ACKNOWLEDGEMENTS

This collaborative project between the Department of Pharmacology, University of Saskatchewan, and the National Research Council of Canada - Plant Biotechnology Institute, would not have been successful without the support of a number of people from both institutions and to whom I am greatly indebted.

To my supervisors Dr. Robert (Bob) Hickie (U of S) and Dr. John Balsevich (NRC-PBI) for their encouragement, comments, guidance, support, patience and criticism throughout the entire course of this investigation. Their help will always be deeply appreciated.

To the members of my thesis advisory committee, Dr. Lily Wu, Dr. John Tucheck, Dr. Rob Warrington, Dr. Jonathan Dimmock, Dr. Bob McNeill and Dr. V. Gopal, for their help, criticism and suggestions.

To Ms. Donna Dunlop for all her invaluable technical assistance, hard work and contributions to the success of this investigation. It has always been a pleasure working with you.

To the Faculty members and staff of the Department of Pharmacology for making me feel like a part of 'one big family'. Your patience, time and dedication in my transition from chemistry to pharmacology will always be treasured.

To Ms. Donna Dodge, Ms. Cindy Wruck and Mr. Bob Wilcox for their support in all aspects during my time in the Department of Pharmacology. All my gratitude goes to you.

To Mr. Greg Bishop and Mrs. Leah Deibert from the NRC-PBI's Plant Natural Products group for all their help in the analytical chemistry and cytotoxic studies of this thesis. Their friendship is also highly appreciated.

To Dr. Patrick Covello and the members of the Plant Natural Products research team at the NRC-PBI for all their support and advice. It has been a pleasure working with you all.

To Dr. Sue Abrams from the Signalling and Plant Metabolism Group of the NRC-PBI for all her help throughout these years, but especially for having introduced me to Dr. John Balsevich.

To Dr. Kutty Kartha, Dr. Wilf Keller and all the people from the NRC-PBI who contributed and that continue contributing to the success of my scientific career. Thank you so much for believing in my research.

To the Cancer Research Centre of the Royal University Hospital for technical assistance and their contribution of the cancer cell lines used in this study.

To the Department of Pharmacology (U of S) for a Teaching and a Research Assistantship; as well as to the Government of Saskatchewan through the Agriculture Development Fund, and the Maunders McNeil Foundation of Calgary for financial support.

I wish to thank Dr. John T. Arnason for accepting the role of the external advisor.

My experience at the University would not have been a good one without the company of friends with whom I could share opinions, ideas, frustrations and complicity and have a good time. To all of them, big thanks.

I would also like to thank Dr. Paul Arnison, Dr. Michael Oelk, Dr. Nienke Lindeboom, Mrs. Jane Fiala and all my colleagues from work at Saponin Inc. for their support in the final stage of this thesis.

Loving thanks to all my friends in Saskatoon; my family-friends. You know who you are. I love you and treasure every minute of your company.

To my music buddies. Music is food for the soul. Let's keep on playin'!

I am also very grateful to my friends from the Hispanic Catholic Community of Saskatoon for their emotional support and guidance.

To my loving family, Claudia, Eric and Diego. For their unconditional love.

ABSTRACT

Medicinal plants have provided important advances in the treatment of numerous diseases and many plant-derived drugs are currently in use or under investigation for the treatment of many ailments including cancer.

A phytochemical analysis of the methanol extract from the seed of *Saponaria vaccaria* L. cultivated in Saskatchewan was performed which resulted in the detection of several bisdesmosidic saponins. A high-performance liquid chromatographic method using photodiode array and single quadrupole electrospray mass detection for analysis and profiling was developed. Due to their structural similarities, purification of bisdesmosidic saponins was challenging. However, monodesmosidic saponin Vaccaroside B and cyclopeptides Segetalin A, Segetalin B, and a new cyclopeptide, segetalin I [whose structure was proposed to be cyclo(Gly¹-Pro²-Tyr³-Tyr⁴-Pro⁵-Phe⁶)], were purified employing various chromatographic techniques such as HPLC, VLC, PTLC).

Crude methanol extracts of *S. vaccaria* seed were evaluated for cytotoxic activity using the methyl-thiazol-tetrazolium non-radioactive cell proliferation assay (MTT assay). Various concentrations of the extract (2-50 µg/mL) were tested against a series of four human cancer cell lines (WiDr, colon; MDA-MB-231, breast; NCI-417, lung and PC-3, prostate). The human foreskin (BJ)-derived normal human fibroblast cell line CRL-2522 was included as a non-cancerous control. Results showed that cytotoxic activities from the seed extract were greater than commercially available *Quillaja saponaria* saponin.

The human cancer cell lines were also exposed to fractions containing high titers of saponins as well as semi-purified saponins (ca. 80%). All bisdesmosidic saponins and fractions thereof showed cytotoxicity against the cell lines studied. The effect was particularly strong in breast and prostate cancer cell lines with IC₅₀ values in the range 1–4 µg/mL. Monodesmosidic saponins, phenolics and cyclopeptides did not show activity even at the highest concentration (50 µg/mL) tested in this study. Chemical modifications of the saponin structures resulted in an overall decrease in activity, but an increase in selectivity in comparison to CRL-2522. Time and concentration-dependent studies using the nuclear stains propidium iodide and Hoechst 33342, demonstrated that the stimulation of apoptosis was the mechanism of cytotoxic action. When breast and prostate cell lines were exposed to small amounts (4-7 µM) of bisdesmosidic saponins Segetalin H (MW 1448) and Segetalin I (MW 1464), it was observed that apoptosis was induced at an early incubation time (4-10 h). Activation of caspases and changes in membrane potential were determined by flow cytometry.

As a result of this study, we propose that triterpene bisdesmosidic saponins from the seed of *Saponaria vaccaria* L. represent a new type of drug having potential antitumor/anticancer activity due to their ability to induce apoptosis *in vitro* in human cancer cell lines at low concentrations. These compounds are extracted from a plant that can be easily cultivated using conventional agricultural equipment in Western Canada.

TABLE OF CONTENTS

PERMISSION TO USE.....	i
DEDICATION.....	ii
ACKNOWLEDGEMENTS.....	iii
ABSTRACT.....	vi
TABLE OF CONTENTS	viii
LIST OF TABLES	xiii
LIST OF FIGURES	xviii
LIST OF COMPOUNDS.....	xxviii
LIST OF ABBREVIATIONS	xxix
GLOSSARY.....	xxxii
1. INTRODUCTION.....	1
1.1. Saponins	1
1.2. Saponins from <i>Quijalla saponaria</i> M.	6
1.3. The Caryophyllaceae Family	8
1.3.1. <i>Saponaria officinalis</i> L. and <i>Saponaria vaccaria</i> L.....	8
1.3.2. Traditional and medicinal uses of <i>Saponaria vaccaria</i> L.	10
1.4. Bioactive metabolites of <i>Saponaria vaccaria</i> L.....	12
1.4.1. Saponins	12

1.4.2. Cyclopeptides.....	17
1.4.3. Phenolic acids	19
1.4.4. Flavonoids.....	20
1.5. Health benefits of saponins	20
1.6. Cancer and Saponins.....	23
1.6.1. Saponins as a preventive strategy	24
1.6.2. Saponins as a therapeutic strategy.....	24
1.7. Apoptosis. An introduction.	27
1.7.1. Causes of apoptosis.....	31
1.7.2. Apoptosis and cancer	32
2. HYPOTHESIS AND OBJECTIVES.....	35
3. EXPERIMENTAL	37
3.1. Plant material and saponin extracts.....	37
3.2. Determination of the cytotoxic activity of plant extracts.....	38
3.2.1. Cell lines and culture.....	38
3.2.2. Sub-culturing (passaging)	39
3.2.3. Harvest of cells for bioassays.....	41
3.2.3.1. Harvesting WiDr, MDA-MB 231, PC-3 and CRL-2522	41
3.2.3.2. Harvesting NCI-417.....	42
3.3. Preparation of drug solutions for cytotoxic assay	43
3.4. Preparation of seed extract solutions	44

3.5.	Cell proliferation assay “MTT” (<i>in vitro</i> bioassay)	45
3.5.1.	Standard CellTiter 96 [®] assay protocol for 96-well plates.....	45
3.6.	Preparation of assay plates for determination of IC ₅₀ values.....	47
3.7.	Color development and data recording	47
3.8.	Data calculation.....	48
3.8.1.	Percentage mortality.....	48
3.8.2.	Calculation of IC ₅₀ values	49
3.9.	Preparation of seed material and chromatographic separations.....	50
3.9.1.	Materials.....	50
3.9.2.	Fractionation of saponin extracts by reverse phase column chromatography (RPCC) using gradient elution.....	50
3.9.3.	Fractionation of saponin extracts by column chromatography (CC) using an isocratic elution system.....	50
3.9.4.	Purification of cyclopeptides from the seed of <i>S. vaccaria</i> L.....	51
3.9.5.	Fractionation by vacuum liquid chromatography (VLC) using gradient elution.....	51
3.9.6.	Analytical thin layer chromatography (TLC)	53
3.9.7.	Purification by preparative thin layer chromatography (PTLC).....	53
3.9.8.	High performance Liquid Chromatography-Photo Diode Array Detection- Mass Spectroscopy (HPLC-PDA-MS) analysis	54
3.10.	Stimulation of apoptosis using flow cytometry	55
4.	RESULTS AND DISCUSSION	57

4.1.	Evaluation of the cytotoxic activity of the methanol extracts of seed from four varieties of <i>Saponaria vaccaria</i> L. on three human cancer cell lines (WiDr, MDA-MB-231 and NCI-417)	57
4.2.	Saponin profile of the seed extracts of <i>S. vaccaria</i> L.	65
4.3.	Reverse phase column chromatography (RPCC), High Performance Liquid Chromatography-Photo Diode Array Detection-Mass Spectrometry (HPLC-PDA-MS) and biological evaluation of fractions.....	66
4.4.	Purification of saponins by column chromatography (CC) using RP-Amberchrome [®] CG 300 chromatographic grade resin, their analysis by HPLC-PDA-MS and biological evaluation of fractions	82
4.5.	Evaluation of selected drugs to be used as potential positive controls in the MTT assay.....	92
4.6.	Chemical modifications of saponins in relation to their cytotoxic activity	96
4.6.1.	Sodium borohydride reduction.....	98
4.6.2.	Methylation reaction with diazomethane (CH ₂ N ₂)	98
4.6.3.	De-acetylation reaction with (mono)ethanolamine (MEA)	100
4.7.	Preliminary studies of the mechanism of action (MOA) of <i>Saponaria vaccaria</i> saponins.....	107
4.7.1.	Fluorescence microscopy studies.....	109
4.8.	Stimulation of apoptosis by <i>Saponaria vaccaria</i> L. saponins.....	117
4.8.1.	Stimulation of apoptosis in human prostate cancer cells (PC-3) by Segetoside H (MW 1448)	117

4.8.2. Stimulation of apoptosis in human breast cancer cells (MDA-MB-231) by Segetoside H (MW 1448)	127
4.8.3. Failure of Segetoside H (MW 1448) to stimulate apoptosis in human fibroblast normal cells (CRL-2522)	131
4.8.4. Stimulation of apoptosis in human prostate cancer cells (PC-3) by Segetoside I (MW 1464)	137
4.8.5. Stimulation of apoptosis in human breast cancer cells (MDA-MB-231) by Segetoside I (MW 1464)	143
4.8.6. Failure of Segetoside I (MW 1464) to stimulate apoptosis in human fibroblast normal cells (CRL-2522)	147
4.9. Purification and cytotoxic evaluation of cyclopeptides from the seeds of <i>S.</i> <i>vaccaria</i> L.	151
5. CONCLUSIONS AND FUTURE WORK	155
5.1. Conclusions	155
5.2. Future Work	159
CITED LITERATURE.....	160
APPENDIX 1	182
APPENDIX 2.....	193

LIST OF TABLES

Table 1.1. Saponins isolated from cow cockle seed.....	16
Table 1.2. Cyclopeptides identified in cow cockle.	17
Table 4.1. IC ₅₀ values of extracts from four varieties of <i>Saponaria vaccaria</i> L. seed and from commercial extract Wang Bu Liu Xing, quillaja and quinoa saponins against the colon cancer cell line WiDr.	61
Table 4.2. IC ₅₀ values of extracts from four varieties of <i>Saponaria vaccaria</i> L. seed and from commercial extract Wang Bu Liu Xing, quillaja and quinoa saponins against the breast cancer cell line MDA-MB-231.	62
Table 4.3. IC ₅₀ values of extracts from four varieties of <i>Saponaria vaccaria</i> L. seed and from commercial extract Wang Bu Liu Xing, quillaja and quinoa saponins against the lung cancer cell line NCI-417.	63
Table 4.4. Fractionation of cow cockle extract (Pink Beauty) on Supelco Discovery DSC-18Lt reverse phase packing.....	67
Table 4.5. Bisdesmosidic saponins observed in <i>Saponaria vaccaria</i> L. var. Scott WT. Retention times were obtained by selected ion extraction from TIC of appropriate quasi-molecular ion. Disaccharide = 3-O-β-D-Galp-(1→2)-β-D- GlcA; trisaccharide = 3-O- β-D-Xylp-(1→3)-[β-D-Galp-(1→2)]-β-D-GlcA.	68
Table 4.6. IC ₅₀ values of extracts and fractions from <i>Saponaria vaccaria</i> L. seed (pink beauty variety) tested in vitro using the MTT bioassay against three human	

<p>cancer cell lines WiDr (colon), MDA-MB-231 (breast), NCI-417 (lung) and human fibroblast normal cell line CRL-2522.</p>	73
<p>Table 4.7. IC₅₀ values (µg/mL) obtained from dose-response curves of the RPCC Fractions 15-16, 25-26 and the 70% methanol extract from commercial quillaja extract on human breast cancer cell line MDA-MB-231.....</p>	78
<p>Table 4.8. IC₅₀ values (µg/mL) from the dose-response curves of monodesmosidic triterpene saponin Vaccaroside B, bisdesmosidic triterpene saponins Segetoside H and Segetoside I isolated from <i>Saponaria vaccaria</i> L. seed, Kochia saponin and horse chestnut β-escin saponin tested in vitro against the cancer cell lines WiDr, MDA-MB-231, and NCI-417, and the normal fibroblast line CRL-2522 using the MTT bioassay.</p>	80
<p>Table 4.9. Characterization of major compounds from fractions eluted from the chromatographic separation of saponin mixture (SPM) by HPLC-PDA-MS analysis. Saponins with higher MW (i.e. 1638, 1640, 1772) are not shown.</p>	82
<p>Table 4.10. IC₅₀ values (µg/mL) obtained from a dose-response curve of semi-pure saponins extracted from <i>Saponaria vaccaria</i> L. seed, tested in vitro against the human cancer cell lines WiDr (colon), MDA-MB-231 (breast), NCI-417 (lung) and PC-3 (prostate) and the human fibroblast normal cell line CRL-2522 using the MTT bioassay.....</p>	90
<p>Table 4.11. IC₅₀ values (µM) of four commercially available drugs against three human cancer cell lines WiDr, MDA-MB-231, NCI-417 and the human fibroblast normal cell line CRL-2522.</p>	92

Table 4.12. Percentage mortality of three cancer cell lines WiDr, MDA-MB-231, and NCI-417, and a normal fibroblast cell line CRL-2522 when tested against various concentrations of vinblastine.....	94
Table 4.13. Possible relationship of de-acetylated reaction products from corresponding parent saponin.	100
Table 4.14. IC ₅₀ values from reaction products from the structural modifications of CC-19 against four cancer cell lines WiDr (colon), MDA-MB-231 (breast), NCI-417 (lung) and PC-3 (prostate) and human fibroblast normal cell line CRL-2522. (n≥6).....	104
Table 4.15. Apoptosis measured in PC-3 cells treated with 14 μM Segetoside H for 20 hrs using the Dual Sensor: MitoCasp™ Assay.....	116
Table 4.16. Apoptosis in PC-3 cells treated with various concentrations of Segetoside H for 26h measured by The Dual Sensor: MitoCasp™ Assay.....	118
Table 4.17. Apoptosis in PC-3 cells treated with 14 μM Segetoside H for various times measured using the Vybrant® Apoptosis Assay Kit #2.	120
Table 4.18. Apoptosis in PC-3 cells treated with 14 μM Segetoside H for various times measured using the APO LOGIX™ Carboxyfluorescein Caspase 9 Detection Kit.	121
Table 4.19. Apoptosis in PC-3 cells treated with various concentrations of Segetoside H for 20 hr measured using the APO LOGIX™ Carboxyfluorescein Caspase 9 Detection Kit.....	123
Table 4.20. Apoptosis in MDA-MB-231 cells treated with 14 μM Segetoside H for various times measured using the Vybrant® Apoptosis Assay Kit #2.	125

Table 4.21. Apoptosis in MDA-MB-231 cells treated with 14 μ M Segetoside H for various times measured using the APO LOGIX TM Carboxyfluorescein Caspase 9 Detection Kit.....	127
Table 4.22. Apoptosis in human fibroblast normal cells (CRL-2522) cells treated with 14 μ M Segetoside H for various times measured using the Dual Sensor: MitoCasp TM Assay.....	129
Table 4.23. Apoptosis in human fibroblast normal cells (CRL-2522) treated with 14 μ M Segetoside H for various times measured using the Vybrant [®] Apoptosis Assay Kit #2.	131
Table 4.24. Apoptosis in CRL-2522 cells treated with 14 μ M Segetoside H for various times measured using the APO LOGIX TM Carboxyfluorescein Caspase 9 Detection Kit.....	133
Table 4.25. Apoptosis in human prostate cancer cells (PC-3) treated with 7 μ M Segetoside I for various times measured using the Dual Sensor: MitoCasp TM Assay.....	135
Table 4.26. Apoptosis in human prostate cancer cells (PC-3) treated with various concentrations of Segetoside I for 26 hr measured using the Dual Sensor: MitoCasp TM Assay.....	137
Table 4.27. Apoptosis measured in human prostate cancer cells (PC-3) treated with 7 μ M Segetoside I for various times measured using the Vybrant [®] Apoptosis Assay Kit #2.	139

Table 4.28. Apoptosis measured in human prostate cancer cells (PC-3) treated with 14 μ M Segetoside I for various times measured using the Vybrant® Apoptosis Assay Kit #2.....	139
Table 4.29. Apoptosis measured in human breast cancer cells (MDA-MB-231) treated with 3.5 μ M Segetoside I for various times using the Dual Sensor: MitoCasp™ Assay.....	141
Table 4.30. Apoptosis in human breast cancer cells (MDA-MB-231) treated with 7 μ M Segetoside I for various times measured using the Vybrant® Apoptosis Assay Kit #2.	143
Table 4.31. Apoptosis in human fibroblast normal cells (CRL-2522) treated with 7 μ M Segetoside I for various times measured using the Dual Sensor: MitoCasp™ Assay.....	145
Table 4.32. Apoptosis in human fibroblast normal cells (CRL-2522) treated with 7 μ M Segetoside I for various times measured using the Vybrant® Apoptosis Assay Kit #2.	147
Table 4.33. IC ₅₀ values (μ g/mL) of cyclic peptides from cow cockle seeds (<i>Saponaria vaccaria</i> L.) tested in vitro on five cancer cell lines (WiDr, colon; MDA-MB-231, breast; NCI-417, lung; PC-3, prostate; and Hs578T, breast) and two normal cell lines (CRL-2522, fibroblast and Hs578BST, breast) using the MTT bioassay. Cisplatin was used as a positive control.	152

LIST OF FIGURES

Figure 1.1. Skeletal types of sapogenins found in the three principal classes of saponins.	2
Figure 1.2. α -Solanine (1) is one of the glycoalkaloids found in several species of the nightshade family (e.g. potatoes and tomatoes). Tomato plants contain the steroidal glycoalkaloid, α -tomatine (2), which is a monodesmosidic saponin with a tetrasaccharide group.	3
Figure 1.3. Structures of the two groups of oat saponins. The monodesmosidic triterpenoid avenacin A-1 (3) is the major saponin in oat roots. Bidesmosidic steroid avenacoside A (not shown) differs from avenacoside B (4) only in that it lacks the terminal $\beta(1\rightarrow3)$ linked D-glucose molecule.	4
Figure 1.4. The basic structure and substitution positions of the majority of the reported saponins from <i>Quillaja saponaria</i>	7
Figure 1.5. <i>Saponaria vaccaria</i> L. (cow cockle).	10
Figure 1.6. Basic structure of the triterpene saponins found in <i>Saponaria vaccaria</i> L. ...	11
Figure 1.7. Structures of the main quillaic acid bidesmosides vaccaroside E (5) and segetoside I (6).	13
Figure 1.8. Structures of the main gypsogenin type bidesmosides vaccaroside G (7) and segetoside H (8).	14
Figure 1.9. Structure of the main gypsogenic acid monodesmosides Vaccaroside A and Vaccaroside B.	15

Figure 1.10. Segetalin A (11) and segetalin B (12), a cyclohexapeptide and a cyclopentapeptide isolated from the seeds of <i>Saponaria vaccaria</i> L. Glycine is numbered as the first amino acid.	18
Figure 1.11. Phenolic acids from <i>Saponaria vaccaria</i> L.	19
Figure 1.12. Two cell death pathways, necrosis and apoptosis. Necrosis involves breakdown of the cellular membrane, which leads to leakage of intracellular proteins to the extracellular space and subsequently, inflammation. Necrosis usually affects large groups of cells while apoptosis typically involves single cells that undergo organised destruction of the cellular cytoskeleton and formation of apoptotic bodies, which are phagocytosed without an inflammatory reaction.	28
Figure 1.13. Schematic representation of some major apoptotic signalling pathways. ...	30
Figure 3.1. CellTiter 96 [®] non-radioactive cell proliferation assay flowchart.	44
Figure 3.2. Molecular structure of 3-(4,5-dimethylthiazol-2-yl)-2,5-diphenyl- tetrazolium bromide (MTT) and its corresponding reaction product (formazan).	45
Figure 3.3. Two-Fold serial dilution for plant extracts at six different concentrations in a 96-well plate.	46
Figure 3.4. IC ₅₀ comparison of saponin-containing fraction CC-19 and cisplatin on human breast cancer cell line MDA-MB-231.	48
Figure 3.5. Separation of cyclopeptide-containing fraction ‘CP A,B,D+’ from the methanol extract of the seeds of cow cockle.	51
Figure 4.1. Mortality induced by saponins present in the 70% MeOH seed extract of four varieties of <i>Saponaria vaccaria</i> L. (a) Scott, (b) Pink Beauty, (c) Mongolia	

and (d) White Beauty at five different concentrations (50, 25, 12.5, 6.25 and 3.13 µg/mL) on three human cancer cell lines.....	58
Figure 4.2. Mortality induced by saponins present in the 70% MeOH seed extract of a) <i>Saponaria vaccaria</i> L. (commercial extract Wang Bu Liu Xing) and b) <i>Quillaja saponaria</i> M. at five different concentrations (n=6) on three human cancer cell lines.....	59
Figure 4.3. Mortality induced by saponins present in the 70% MeOH seed extract of four <i>Saponaria vaccaria</i> L. varieties (Scott, Pink Beauty, Mongolia and White Beauty); a commercial extracts from <i>S. vaccaria</i> seed (Wang Bu Liu Xing) and <i>Quillaja saponaria</i> M. on a) human colon cancer cell line WiDr, b) human breast cancer cell line MDA-MB-231, and c) human lung cancer cell line NCI-417.	60
Figure 4.4. HPLC chromatogram of total MeOH extract from <i>Saponaria vaccaria</i> L var. Pink Beauty.....	64
Figure 4.5. Liquid chromatography-Photo Diode Array profiles of the crude methanol extract (a) and two fractions (b, c) eluted from the column during the separation of compounds according to their different polarities.	66
Figure 4.6. Gross structures of quillaic acid-type bisdesmosidic triterpene saponins identified in <i>Saponaria vaccaria</i> L.....	69
Figure 4.7. Mortality induced by fractions collected from the reverse phase chromatographic separation (RPCC) of a 70% MeOH seed extract from <i>Saponaria vaccaria</i> L. var. Pink Beauty on (a) human colon cancer cell line WiDr; (b) human breast cancer cell line MDA-MB-231; (c) human lung	

<p>cancer cell line NCI-417; and (d) human fibroblast normal cell line CRL-2522. Standard deviations have been omitted for clarity.....</p>	72
<p>Figure 4.8. Comparison of IC₅₀ values of extracts and fractions from seed of <i>Saponaria vaccaria</i> L. (pink beauty variety) and commercially available saponin mixture from <i>Quillaja saponaria</i> (Sigma brand, control) tested <i>in vitro</i> using the MTT bioassay against the human colon cancer cell line WiDr.</p>	74
<p>Figure 4.9. Comparison of IC₅₀ values of extracts and fractions from seed of <i>Saponaria vaccaria</i> L. (pink beauty variety) and commercially available saponin mixture from <i>Quillaja saponaria</i> (Sigma brand, control) tested <i>in vitro</i> using the MTT bioassay against the breast cancer cell line MDA-MB-231.....</p>	75
<p>Figure 4.10. Comparison of IC₅₀ values of extracts and fractions from seed of <i>Saponaria vaccaria</i> L. (pink beauty variety) and commercially available saponin mixture from <i>Quillaja saponaria</i> (Sigma brand, control) tested <i>in vitro</i> using the MTT bioassay against the human lung cancer cell line NCI-417.</p>	76
<p>Figure 4.11. Comparison of IC₅₀ values of six fractions from seed of <i>Saponaria vaccaria</i> L. (pink beauty variety) tested <i>in vitro</i> using the MTT bioassay against the human fibroblast normal cell line CRL-2522.</p>	77
<p>Figure 4.12. Mortality induced by bisdesmosidic triterpene saponin a) Segetoside H (MW 1448) and b) Segetoside I (MW 1464) isolated from the seed of <i>Saponaria vaccaria</i> L. at six different concentrations on five human cell lines. (<i>n</i> ≥ 6).....</p>	79
<p>Figure 4.13. Total ion chromatogram of fraction CC-12 showing the main identified saponins and cyclopeptide segetalin A.</p>	83

Figure 4.14. Total ion chromatogram of fraction CC-16 showing segetoside I, vaccaroside G, and a newly identified saponin, all overlapped under one signal.	83
Figure 4.15. HPLC-PAD-MS chromatogram of fraction CC-19 showing identified known and unknown saponins.	84
Figure 4.16. Mortality induced by fractions collected from the chromatographic separation of a saponin mixture (SPM) from the seed of <i>Saponaria vaccaria</i> L. at different concentrations ($n \geq 3$) on human cancer cell lines (a) WiDr, colon; (b) MDA-MB-231, breast; (c) NCI-417, lung; (d) PC-3, prostate; and (e) human normal fibroblast cell line CRL-2522.	85
Figure 4.17. Mortality induced by individual fractions collected from the chromatographic separation of a saponin mixture (SPM) from the seed of <i>Saponaria vaccaria</i> L. at different concentrations ($n \geq 3$) on five human cell lines.	86
Figure 4.18. Comparison of IC_{50} values of fractions from the chromatographic separation of <i>Saponaria vaccaria</i> L. saponin extract on four human cancer cell lines WiDr (colon), MDA-MB-231 (breast), NCI-417 (lung), PC-3 (prostate), and the human fibroblast normal cell line CRL-2522.	91
Figure 4.19. Mortality induced by Vinblastine at different concentrations ($n=3$) on human cancer cell lines WiDr (colon), MDA-MB-231 (breast), NCI-417 (lung) and human fibroblast normal cell line CRL-2522.	95

Figure 4.20. A study of the structure-activity relationship of saponins with sodium borohydride (NaBH ₄), diazomethane (CH ₂ N ₂) and (mono)ethanolamine (MEA).	96
Figure 4.21. Comparison of chromatograms of saponin mixture CC-19 with its corresponding methylated products. a, b, c, and d correspond to the methylated saponins 1420 (1406+14), 1478 (1464+14) and 1552 m/z (1538+14), respectively.	98
Figure 4.22. LC-MS chromatogram of the de-acetylation reaction of saponin-containing fraction CC-19. Peaks labeled a–i correspond to de-acetylated saponins which showed a decrease of m/z 42 or 84 from the parent saponin, corresponding to the loss of either one or two acetyl groups, respectively.	99
Figure 4.23. Mortality induced by bisdesmosidic saponin-enriched fraction CC-19 and corresponding chemical derivatization products on (a) human colon cancer cell line WiDr, (b) human breast cancer cell line MDA-MB-231, (c) human lung cancer cell line NCI-417, (d) human prostate cancer cell line, and (e) human fibroblast normal cell line CRL-2522.	101
Figure 4.24. Mortality induced by bisdesmosidic saponin-enriched fraction CC-19 on five human cell lines. Mortality induced by the reaction products of the bisdesmosidic saponin-enriched fraction CC-19 upon treatment with diazomethane (CH ₂ N ₂) on five human cell lines.	102
Figure 4.25. Mortality induced by bisdesmosidic saponin-enriched fraction CC-19, its corresponding chemical modified structures and cisplatin on (a) human breast	

cancer cell line Hs578 T and (b) human breast normal cell line Hs578 BST.....	103
Figure 4.26. Cytotoxic comparison (IC ₅₀ values) of saponin-containing fraction CC-19 with its chemically modified reaction products (reduced, de-acetylated and methylated saponins) and cisplatin on five human cancer cell lines (WiDr, colon; MDA-MB-231, breast; NCI-417, lung; PC-3, prostate and Hs578 T, breast) and two human normal cell lines (CRL-2522, fibroblast and Hs578 BST, breast).	105
Figure 4.27. MDA-MB-231 cells used as control and treated with propidium iodide. No irregularities in morphology or size were detected.....	107
Figure 4.28. MDA-MB-231 cells treated with triton-X and stained with Hoechst 33342 after 4h of incubation. Cells were all dead.	108
Figure 4.29. Cisplatin treated MDA-MB-231 cells stained with a) Hoechst 33342 after 24h of incubation, and b) propidium iodide after 48 h of incubation. Cells show characteristic features of apoptosis such as nuclei condensation (brighter blue or red), blebbing and cell shrinkage.....	109
Figure 4.30. MDA-MB-231 cells treated with <i>Saponaria</i> saponin at a concentration of 3 µg/mL at 0 and 6 h of incubation and upon treatment with propidium iodide. Arrows point toward apoptotic cells.....	111
Figure 4.31. MDA-MB-231 cells treated with <i>Saponaria</i> saponin at a concentration of 3 µg/mL after 12 h of incubation and upon treatment with Hoechst 33342. Some cells undergoing apoptosis were labeled A – F.	112

Figure 4.32. Comparison of untreated MDA-MB-231 cells after 10 h of incubation with corresponding <i>Saponaria</i> saponin treated cells at concentrations of 10 and 25 µg/mL.....	113
Figure 4.33. Fluorescent microscopy of Hoechst 33342 stained nuclei in untreated (a,c,e) and PC1448 treated (b,d,f) CRL-2522 (a,b), PC-3 (c,d) and MDA-MB-231 (e,f) cells. Red arrows show nuclear changes characteristic of apoptotic cells.....	114
Figure 4.34. Apoptosis measured in PC-3 cells treated with 14 µM Segetoside H (MW 1448) for various times using the Dual Sensor: MitoCasp™ Assay.	117
Figure 4.35. Apoptosis measured in PC-3 cells treated with various concentrations of Segetoside H for 26h using The Dual Sensor: MitoCasp™ Assay.	119
Figure 4.36. Apoptosis measured in PC-3 cells treated with 14 µM Segetoside H for various times using the APO LOGIX™ Carboxyfluorescein Caspase 9 Detection Kit.....	122
Figure 4.37. Apoptosis measured in PC-3 cells following a 20 hr treatment with various concentrations of Segetoside H using the APO LOGIX™ Carboxyfluorescein Caspase 9 Detection Kit.....	124
Figure 4.38. Apoptosis in MDA-MB-231 cells treated with 14 µM Segetoside H for various times measured using the Vybrant® Apoptosis Assay Kit #2.	126
Figure 4.39. Apoptosis in MDA-MB-231 cells treated with 14 µM Segetoside H for various times measured using the APO LOGIX™ Carboxyfluorescein Caspase 9 Detection Kit.....	128

Figure 4.40. Apoptosis in human fibroblast normal cells (CRL-2522) treated with 14 μ M Segetoside H for various times measured using the Dual Sensor: MitoCasp TM Assay.....	130
Figure 4.41. Apoptosis in CRL-2522 cells treated with 14 μ M Segetoside H for various times measured using the Vybrant® Apoptosis Assay Kit #2.....	132
Figure 4.42. Apoptosis in human fibroblast normal cells (CRL-2522) treated with 14 μ M Segetoside H for various times measured using the APO LOGIX TM Carboxyfluorescein Caspase 9 Detection Kit.	134
Figure 4.43. Apoptosis in human prostate cancer cells (PC-3) treated with 7 μ M Segetoside I for various times measured using the Dual Sensor: MitoCasp TM Assay.....	136
Figure 4.44. Apoptosis in human prostate cancer cells (PC-3) treated with various concentrations of Segetoside I for 26h measured using the Dual Sensor: MitoCasp TM Assay.....	138
Figure 4.45. Apoptosis in human prostate cancer cells (PC-3) treated with 7 μ M Segetoside I for various times measured using the Vybrant® Apoptosis Assay Kit #2.	140
Figure 4.46. Apoptosis in human breast cancer cells (MDA-MB-231) treated with 3.5 μ M Segetoside I for various times measured using the Dual Sensor:MitoCasp TM Assay.....	142
Figure 4.47. Apoptosis in human breast cancer cells (MDA-MB-231) treated with 7 μ M Segetoside I for various times measured using the Vybrant® Apoptosis Assay Kit #2.	144

Figure 4.48. Apoptosis in human fibroblast normal cells (CRL-2522) treated with 7 μ M Segetoside I for various times measured using the Dual Sensor:MitoCasp TM Assay.....	146
Figure 4.49. Apoptosis in human fibroblast normal cells (CRL-2522) treated with 7 μ M Segetoside I for various times measured using the Vybrant [®] Apoptosis Assay Kit #2.	148
Figure 4.50. Cyclic peptide-containing fraction showing a mixture of segetalin A, B, D, and newly identified segetalin I.	150
Figure 4.51. Structure of segetalin I (77), chemical analysis and diagnostic fragments observed in its mass spectrum (ESI ⁺).	151

LIST OF COMPOUNDS

COMPOUND 1.	α -Solanine.....	3
COMPOUND 2.	α -Tomatine.....	3
COMPOUND 3.	Avenacin A-1.....	4
COMPOUND 4.	Avenacoside B.....	4
COMPOUND 5.	Vaccaroside E.....	13
COMPOUND 6.	Segetoside I.....	13
COMPOUND 7.	Vaccaroside G.....	14
COMPOUND 8.	Segetoside H.....	14
COMPOUND 9.	Vaccaroside A.....	15
COMPOUND 10.	Vaccaroside B.....	15
COMPOUND 11.	Segetalin A.....	18
COMPOUND 12.	Segetalin B.....	18
COMPOUND 13.	Phenylpropanoid glycoside.....	19
COMPOUND 14.	Dihydroferulic acid.....	19
COMPOUND 15.	Vaccarin.....	20
COMPOUND 16.	Digoxin.....	22
COMPOUND 17.	Digitoxin.....	22
COMPOUND 18.	Glycyrrhizin.....	23
COMPOUND 19.	Segetalin I.....	77

LIST OF ABBREVIATIONS

$[\alpha]_D$	Specific optical rotation
λ_{\max}	Wavelength of maximum absorption
CC	Column chromatography
CH₂N₂	Diazomethane
¹³C-NMR	Carbon-13 nuclear magnetic resonance
CP	Cyclopeptide
CO₂	Carbon dioxide
CRL-2522	A normal human foreskin fibroblast cell line
DMSO	Dimethyl sulfoxide
DMSO-d₆	Dimethyl sulfoxide (hexadeuterated form – C ₂ D ₆ OS)
DOI	Digital Object Identifier
EDTA	Ethylenediaminetetraacetic acid
ESI	Electrospray ionization
Et₂O	Diethyl ether
et alii (<i>et al.</i>)	And others
EtOAc	Ethyl acetate
FBS	Fetal bovine serum
FDA	Food and Drug Administration (U.S.A.)
¹H-NMR	Proton nuclear magnetic resonance
HRMS	High-resolution mass spectrometry
H₂SO₄	Sulfuric acid

Hex	Hexane
HPLC-PDA-MS	High Performance Liquid Chromatography - Photo Diode Array Detector - Mass Spectrometry
IC₅₀	The concentration of an extract or drug that is required for 50% inhibition of cell growth
ISBN	International Standard Book Number
KBr	Potassium bromide
MDA-MB-231	A human breast cancer cell line
MEA	(Mono)ethanolamine
MeCN	Acetonitrile
MeOH	Methanol
MOA	Mechanism of Action
MTT	3-(4,5-Dimethylthiazol-2-yl)-2,5-diphenyltetrazolium bromide
<i>m / z</i>	mass-to-charge ratio
NaBH₄	Sodium borohydride
NaOH	Sodium hydroxide
NCI-417	A human lung cancer cell line
NRC-PBI	National Research Centre – Plant Biotechnology Institute
PBM	Saponaria vaccaria L. var. Pink Beauty
PC-3	A human prostate cancer cell line
PCD	Programmed cell death
PDA	Photo Diode Array
PI	Propidium iodide

PTLC	Preparative thin layer chromatography
Pyr-d₅	Pyridine (pentadeuterated form – C ₅ D ₅ N)
RPCC	Reverse phase column chromatography
RP	Reverse phase
Rt	Retention time
SPM	Saponin mixture
TIC	Total ion chromatogram
TLC	Analytical thin layer chromatography
USDA/ARS/GRIN	United States Department of Agriculture (USDA). Agricultural Research Service (ARS), Beltsville Area. Germplasm Resources Information Network
VLC	Vacuum Liquid Chromatography
WBM	Saponaria vaccaria L. var. White Beauty
WiDr	A cell line derived from a human colon carcinoma
WT	Wild type

GLOSSARY

Adjuvants: Pharmacological or immunological agents that modify the effect of other agents (e.g., drugs, vaccines) while having few if any direct effects when given by themselves. In this sense, they are roughly analogous to chemical catalysts.

Anticancer: Used against or tending to arrest or prevent cancer. Anticancer activity can only be determined from human trials.

Antimicrobial: Destroying or inhibiting the growth of microorganisms.

Antineoplastic: Inhibiting or preventing the growth and spread of neoplasms or malignant cells.

Antitumor: Effective against a model tumor system *in vivo*. Implies selectivity against tumor compared to host non-cancerous cells.

Apaf-1: Apoptotic protease activating factor 1 is a cytosolic protein involved in cell death or apoptosis. When Cytochrome c is released from the mitochondria, it interacts with Apaf-1 and dATP to form the apoptosome, a large oligomeric protein complex which can activate caspase 9.

Bcl-2: The prototype for a family of mammalian genes and the proteins they produce. They govern mitochondrial outer membrane permeabilization (MOMP) and can be either pro-apoptotic (Bax, BAD, Bak and Bok among others) or anti-apoptotic (including Bcl-2 proper, Bcl-xL, and Bcl-w, among an assortment of others).

Cancer: A general name for more than 200 distinct diseases in which abnormal cells grow out of control; a malignant tumor.

Cancer cells: The smallest indivisible components which in aggregate constitute a malignant tumor.

Carcinoma: Cancer that begins in the lining or covering of an organ. Skin, lung, breasts, prostate are epithelial lining cell cancers and constitute the most common forms of cancer in the human body.

Caspases: Cysteine-dependent ASPartyl-specific proteASE. A family of proteins that are one of the main executors of the apoptotic process and inflammation. They belong to a group of enzymes known as cysteine proteases and exist within the cell as inactive pro-forms or zymogens. These zymogens can be cleaved to form active enzymes following the induction of apoptosis. As proteases, they are enzymes that cleave other proteins. They are called cysteine proteases, because they use a cysteine residue to cut those proteins, and are called caspases because the cysteine residue cleaves their substrate proteins at the aspartic acid residue.

Chemoprevention: Ingestion of non-toxic quantities of chemical agents (dietary or pharmaceutical) that are capable of preventing, inhibiting or reversing the process of carcinogenesis.

Chemotherapy: The use of drugs to treat cancer.

Chemotherapy Drugs: Cell killing and growth inhibitory agents utilized alone or in combination for the treatment of cancer.

Cultivar: A cultivated plant that has been selected and given a unique name because it has desirable characteristics (decorative or useful) that distinguish it from otherwise similar plants of the same species. When propagated it retains those characteristics.

Cytotoxic: Toxic to cells in culture. Does not imply any selective effect on cancer cells versus normal cells. Subtypes are:

Cytostatic: stopping cell growth (often reversible)

Cytocidal: killing cells.

Fas ligand or FasL: A type II transmembrane protein that belongs to the tumor necrosis factor (TNF) family. The binding of Fas ligand with its receptor induces apoptosis. Fas ligand-receptor interactions play an important role in the regulation of the immune system and the progression of cancer.

Glycoside: Any of a group of organic compounds, occurring abundantly in plants, that yield a sugar and one or more non-sugar substances on hydrolysis.

Hormesis (from Greek *hormain*, meaning “to excite”) is the term for generally-favorable biological responses to low exposures to toxins and other stressors. A pollutant or toxin showing hormesis thus has the opposite effect in small doses than in large doses. In toxicology, hormesis is a dose response phenomenon characterized by a low dose stimulation, high dose inhibition, resulting in either a J-shaped or an inverted U-shaped dose response.

Interferons (IFNs): Natural proteins produced by the cells of the immune system of most vertebrates in response to challenges by foreign agents such as viruses, parasites and tumor cells. Interferons belong to the large class of glycoproteins known as cytokines. Interferons are produced by a wide variety of cells in response to the presence of double-stranded RNA, a key indicator of viral infection. Interferons assist the immune response by inhibiting viral replication within host cells, activating natural killer cells, increasing antigen presentation to lymphocytes, and inducing the resistance of host cells to viral infection.

Interleukins: A group of cytokines (secreted signaling molecules) that were first seen to be expressed by white blood cells (leukocytes, hence the *-leukin*) as a means of communication (*inter-*). It has been found that interleukins are produced by a wide variety of bodily cells. The function of the immune system depends in a large part on *interleukins*, and rare deficiencies of a number of them have been described, all

featuring autoimmune diseases or immune deficiency. For example, IL-2 from TH1-cells, stimulates growth and differentiation of T cell response.

Jurkat cells: An immortalized line of T lymphocyte cells that are used to study acute T cell leukemia and T cell signaling. The Jurkat cell line (originally called JM) was established in the late 1970s from the peripheral blood of a 14 year old boy with T cell leukemia.

Malignant: Used to describe a cancerous tumor.

MTT assay: A laboratory test and a standard colorimetric assay (an assay which measures changes in color) for measuring cellular proliferation (cell growth). It can also be used to determine cytotoxicity of potential medicinal agents and other toxic materials. Yellow MTT (3-(4,5-Dimethylthiazol-2-yl)-2,5-diphenyltetrazolium bromide, a tetrazole) is reduced to purple formazan in the mitochondria of living cells.

Neoplasm: A new growth of tissue serving no physiological function: tumor.

Sapogenin: The non-sugar portion of saponin that is typically obtained by hydrolysis.

Saponin: Any of various plant glycosides that form soapy lathers when mixed and agitated with water. They are used in detergents, foaming agents and emulsifiers. While some saponins may be very toxic, even lethal, there are other saponins that are being researched for its anti-oxidant properties, and used against cancer.

Surfactant: "**Surface acting agent**". Surfactants are usually organic compounds that are amphipathic, meaning they contain both hydrophobic groups (their "tails") and hydrophilic groups (their "heads"). Therefore, they are soluble in both organic solvents and water.

Terpene: Any of a class of hydrocarbons occurring widely in plants and animals and empirically regarded as built up from isoprene, a hydrocarbon consisting of five carbon atoms attached to eight hydrogen atoms (C₅H₈). The term is often extended to the terpenoids, sometimes referred to as isoprenoids, which are oxygenated derivatives of these hydrocarbons.

Traditional Chinese Medicine: Medical science governing the theory and practice of traditional Chinese medicine. It includes Chinese medication, pharmacology/herbology, acupuncture, massage and Qigong.

Tumor: An abnormal benign or malignant mass of tissue that is not inflammatory, arises from a variety of causes from cells of preexistent tissue, and possesses no physiologic function.

Tumor necrosis factors: The TNF-family refers to a group of cytokines family that can cause apoptosis. TNF-alpha is the most well-known member of this class, and sometimes referred to when the term "tumor necrosis factor" is used. TNF acts via the TNF Receptor (TNF-R) and is part of the extrinsic pathway for triggering apoptosis.

Trypsinization: Releasing cells from the monolayer from one culture vessel to another using purified trypsin so that the cells can be easily handled by pipetting and diluting. (Trypsin is a popular detachment factor because it digests the proteins that keep the cell attached to a surface. Prolonged exposure to trypsin can result in too much of the cell being digested, which can cause cell damage or destruction.)

CHAPTER 1 INTRODUCTION

1.1. Saponins

Saponins are naturally occurring glycosylated compounds generated by the terpenoid biosynthetic pathway, which are found mainly, but not exclusively in the plant kingdom (Oleszek, 2002). The occurrence of saponins in plants is widespread but concentrations are highly variable. Chemically, the term saponin defines a group of structurally diverse molecules which can be divided into three major classes, depending on the structure of the aglycone or non-saccharide portion (called the *genin* or *sapogenin*): triterpene glycosides, steroid glycosides, and steroid alkaloid glycosides (Fig. 1.1) (Hostettmann and Marston, 1995). The sugars can be attached as one, two, and less commonly three sugar chains and the terms monodesmoside, bidesmoside, and tridesmoside has been given to these saponins, respectively (Greek *desmos* = chain) (Joshi *et al.*, 2002, Oleszek, 2002).

Steroidal saponins are found in the monocotyledonous plant families (those related to the grasses) such as Dioscoreaceae, Liliaceae, Agavaceae and Amaryllidaceae, and, among the dicotyledons (the great bulk of plant families), in such as the foxglove (*Digitalis* spp.), nightshade families and in fenugreek (*Trigonella foenum-graecum*). The triterpenoid saponins are rare in the monocotyledons, but are widely present in dicotyledons (*Leguminosae*, *Araliaceae*, *Caryophyllaceae*). Saponins are found in various parts of the plant: leaves, stems, roots, bulbs, blossom, and fruit. They are

characterized by their bitter taste, and their ability to hemolyze red blood cells. A single plant species may contain a complex mixture of saponins (Sparg *et al.*, 2004).

Triterpenoid saponins are found in many cultivated crops and legumes such as soybeans, beans, peas, lucerne, and also in onion, tea, spinach, sugar beet, quinoa, liquorice, sunflower, horse chestnut, ginseng. Steroidal saponins are common in plants used as herbs or for their health-promoting properties including oats, capsicum peppers, aubergine, tomato seed, alliums, asparagus, yam, fenugreek, yucca and ginseng (Fenwick *et al.*, 1991). Steroidal glycoalkaloids are natural toxins in the *Solanaceae* family. These compounds are also found in common food crops such as in potato and tomato, where they are bound to sugar moieties to form glycosides (Morrissey and Osbourn, 1999; Arneson and Durbin, 1968). It is noteworthy that the levels of these compounds in commercially available, quality potato tubers and tomatoes do not represent a health hazard to humans (Smith *et al.*, 1996). The chemical structures of the steroidal glycoalkaloids α -solanine (**1**) and α -tomatine (**2**) are shown in Fig. 1.2.

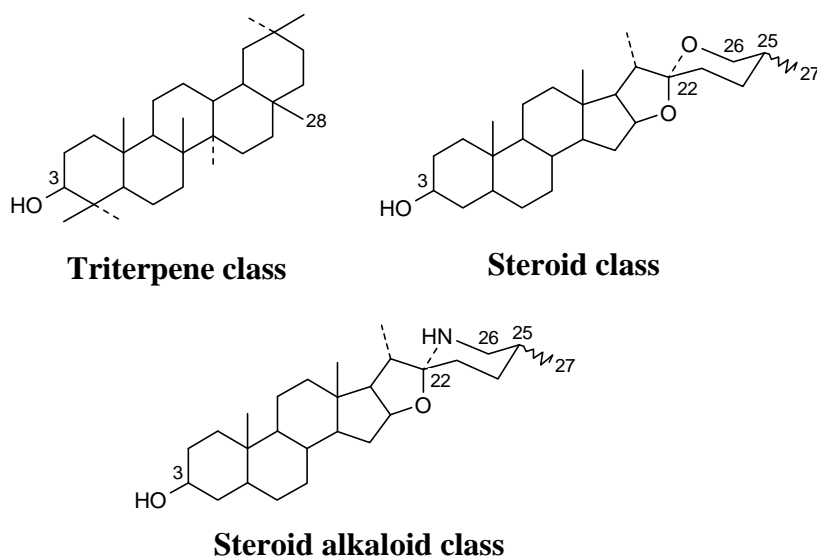
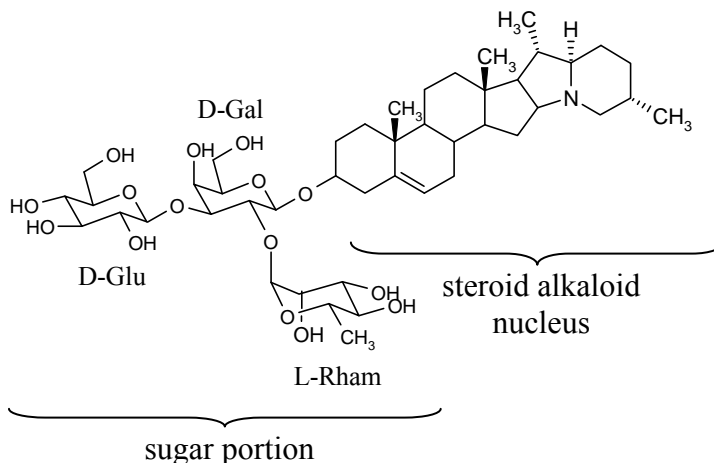

Figure 1.1. Skeletal types of sapogenins found in the three principal classes of saponins.

**α -Solanine
(1)**



**α -Tomatine
(2)**

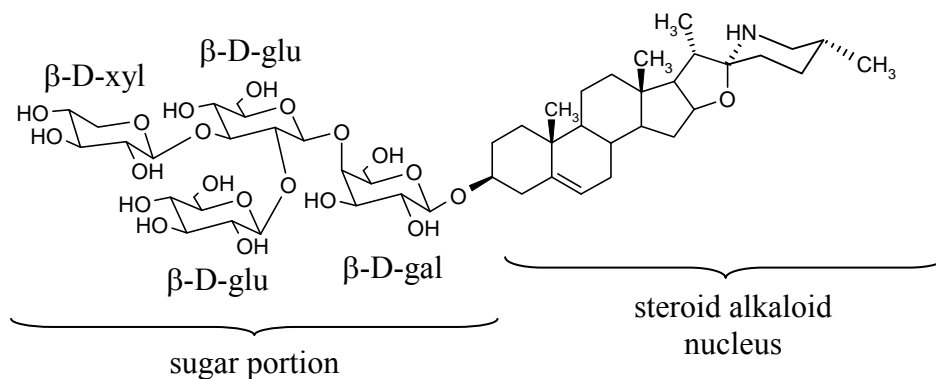

Figure 1.2. α -Solanine (1) is one of the glycoalkaloids found in several species of the nightshade family (e.g. potatoes and tomatoes). Tomato plants contain the steroidal glycoalkaloid, α -tomatine (2), which is a monodesmosidic saponin with a tetrasaccharide group.

Two very well known plants containing saponins are oats and tomatoes. Oats have both triterpenoid (avenacins) and steroidal (avenacosides) saponins. The avenacin family consists of 4 closely related saponins; avenacins A-1 (3) and B-1 are esterified with N-methyl anthranilic acid and hence are autofluorescent under UV light. Avenacins A-2 and B-2 are esterified with benzoic acid and are only weakly autofluorescent. The steroidal oat leaf saponins avenacosides A and avenacoside B (4) both have two sugar

chains, one at C-3 and one at C-26 (Osbourn *et al.*, 2003; Crombie and Crombie, 1986; Begley *et al.*, 1986). The chemical structures of avenacin A-1 and avenacoside B are show in Fig. 1.3.

Avenacin A-1

(3)

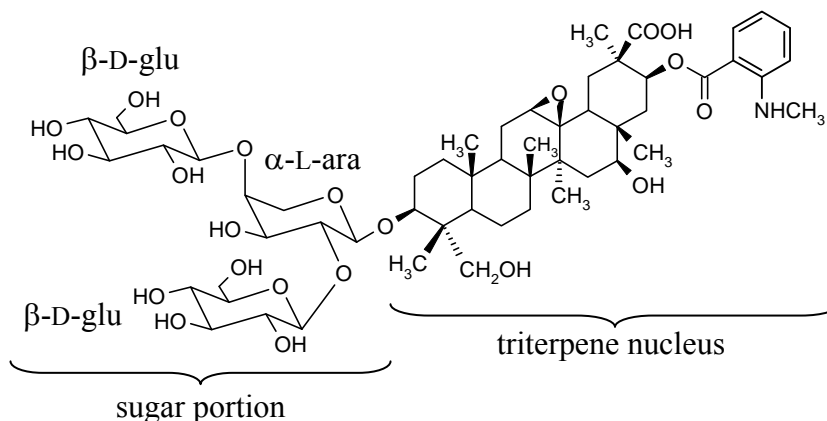

Avenacoside B

(4)

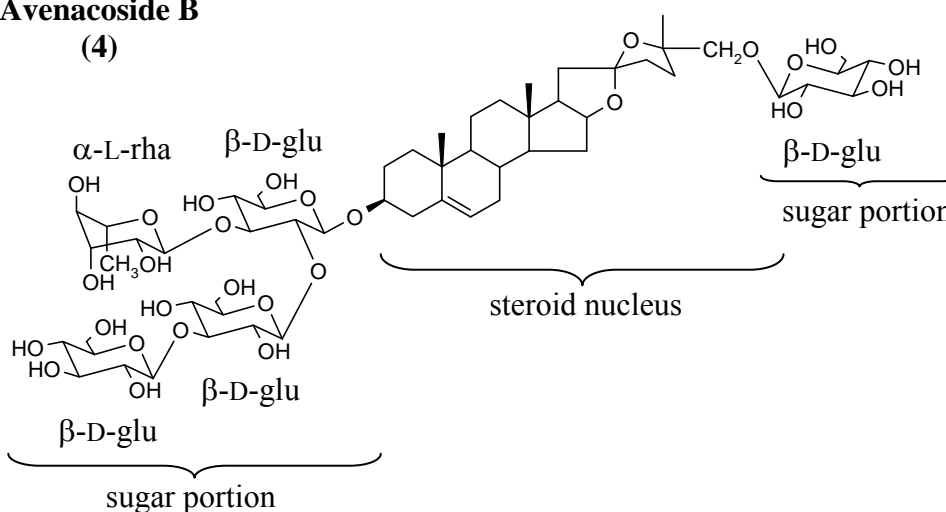

Figure 1.3. Structures of the two groups of oat saponins. The monodesmosidic triterpenoid avenacin A-1 (3) is the major saponin in oat roots. Bidesmosidic steroid avenacoside A (not shown) differs from avenacoside B (4) only in that it lacks the terminal β(1→3) linked D-glucose molecule.

Saponins often occur as complex mixtures, and saponin content and composition may vary markedly depending on the genetic background of the plant material, the tissue type, the age and physiological state of the plant and environmental factors (Hostettmann and Marston, 1995; Rao and Sung, 1995; Hostettmann *et al.*, 1991; Fenwick *et al.*, 1991; Price *et al.*, 1987; Roddick, 1974).

Plants containing a high titer of saponins display a soapy/foamy solution when crushed and shaken with water. This characteristic distinguishes them from other plants, and because of their natural detergent characteristics, the water extracts of foliage or roots of some high saponin containing plants (e.g. *Saponaria officinalis* L.) were historically used as soaps (Osbourn 1996). Their presence in plants is thought to act as a deterrent to herbivores - the taste is generally bitter and astringent and can cause gastric irritation if ingested. In contrast, saponins from liquorice are sweet in taste. The toxic action of some saponins to fungi is associated with their ability to complex with membrane steroids and cause pore-formation (Morrissey and Osbourn, 1999). In general, saponins are also highly toxic to some creatures such as fish where the gills are permeabilized with concomitant bleeding. If injected into the bloodstream they can disrupt the membranes of red cells. (Marston *et al.*, 2000)

Humans generally do not suffer severe poisoning from saponins since it takes a large oral dose of saponins to produce a toxic effect. Because of this, saponins have been used in sneezing powders, emetics, and cough syrups to facilitate expectoration. Most saponins are also diuretics. Commercially, they are used in toothpaste and in gargles, shampoos or foaming agents in drinks such as root beer (Susumu *et al.*, 1993; Yoshiaki and Mitsuru, 1992). They are also used in fire extinguishers as a foam

producer and in photographic emulsions. Industrially, they are used in mining for ore separation and also in electroplating to minimize acid vapours (Glüçlü-Üstlündağ and Mazza, 2007; Cheng *et al.*, 2004; San Martin and Briones, 1999). Although saponins are considered a single class of compounds, their structural differences are quite large. This is reflected in the great variety of saponins reported from varied sources showing diverse biological applications, toxicities and commercial applications (Glüçlü-Üstlündağ and Mazza, 2007). The biological applications of saponins are described below.

1.2. Saponins from *Quillaja saponaria* M.

Quillaja saponins are natural tensoactives (or surfactants) derived from the bark of *Quillaja saponaria* M. (family *Rosaceae*), which is a large evergreen tree indigenous to Chile, Peru and Bolivia. They have been used for over 100 years as foaming agents in food and beverages, production of photographic films, adjuvants in animal vaccines, cosmetics, etc. There are over 300 scientific papers and international patents describing the use of quillaja saponins for different applications. Saponins of the quillaja type (Fig. 1.4) are a complex mixture of glycosylated triterpenes based on quillaic acid, and the price of crude extract varies remarkably, depending on grade and purity of extract. Not unexpectedly, the population of wild trees in recent years has been decreasing dramatically due to continuous harvesting. This has been reflected by an increase in extract price over the past few years (San Martin and Briones, 2000; San Martin and Briones, 1999).

As mentioned above, saponins are considered to be toxic to fish and snails (Price *et al.*, 1987). However, quillaja saponins have weak molluscicidal and fish killing activities and since these saponins have been shown to have no adverse effects on mice and rats, they are categorized as GRAS (generally recognized as safe) for human consumption by the FDA of the United States of America (Sen *et al.*, 1998a).

Quillaja-type saponins are also produced by a number of other plants, particularly members of the Caryophyllaceae, several of which not only grow readily in the Canadian prairies, and are adaptable to large scale cultivation (Goering *et al.*, 1966).

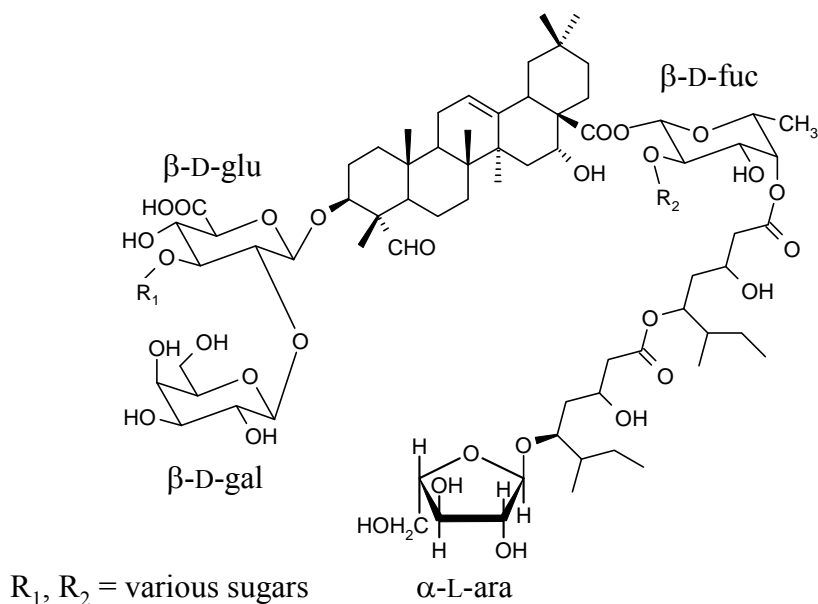

Figure 1.4. The basic structure and substitution positions of the majority of the reported saponins from *Quillaja saponaria*.

1.3. The Caryophyllaceae Family

The Caryophyllaceae (pink family) is a large and widely distributed family, comprising over 2000 species in 80 genera found mostly throughout the North Temperate Zone, especially in the northern Mediterranean countries although it is also well represented in North America. Most species are herbs or sub-shrubs. Very many species and cultivars of *Dianthus* L., the carnations, pinks, and sweet williams, are available from seed merchants, nurserymen, and florists. *Gypsophila* L. (baby's breath) species and cultivars are also popular for floral arrangements and bouquets, and are commonly grown as decorative garden plants (Caryophyllaceae 2008; Rabeler and Hartman, 2005; Watson and Dallwitz, 1992; Montana Plant Life). Several members of the pink family are known for their saponin content. The genus *Saponaria* L. was named for its soap-like properties.

1.3.1. *Saponaria officinalis* L. and *Saponaria vaccaria* L.

Saponaria officinalis L. also known as soapwort, bouncing bet, sweet betty, wild sweet william, bruisewort, dog cloves, old maids' pink, soap root, latherwort, fuller's herb, fuller's grass, foam dock, gill-run-by-the-street saponary, lady-by-the-gate, crow soap, hedge pink, farewell summer; was introduced from Europe and has rapidly adapted to North America. It is a perennial, often growing 1.5 to 2 meters in height (approx. 5 to 6 feet). This species is most often encountered in sandy soil along stream banks, roadsides and waste places (Natural Resources Canada, Global Biodiversity Information Facility; Ministry of Agriculture, Food and Rural Affairs, Ontario; USDA/ARS/GRIN; Montana Plant Life). The medicinal properties of *S. officinalis* are

due to its hormone-like saponins. This plant has a traditional reputation for both the internal and external treatment of skin conditions such as eczema, psoriasis, acne and boils. Its use as a remedy for gout and rheumatism is probably due to the anti-inflammatory action of the saponins. Their strongly irritant action in the gut stimulates the cough reflex and increases the production of more fluid mucus within the respiratory tract. It has been used in the treatment of dry cough. A popular home remedy for poison ivy can be derived from the crushed roots of this plant. The root is also said to encourage bile flow, and is reported to have an effect on gallstones. It is laxative in quite small doses. If ingested for several days, toxic signs are noted in some animals, which can include: mild depression, vomiting (in those species that can vomit), abdominal pain, diarrhea (which may become bloody). Overall, this toxicosis is not encountered frequently (Montana Plant Life; Plants for a future: *Saponaria officinalis* Database).

A similar species, cow cockle (*S. vaccaria* L. syns. *S. hispanica* Mill., *Vaccaria hispanica* (Mill.) Rauschert, *V. pyramidata* Medik., *V. segetalis* Asch.), also known as China cockle and cow-herb, is more slender and only grows to about 1 meter (3 feet) in height (Fig. 1.5a). Cow cockle is also an introduced species and is considered a Class 3 noxious weed in Saskatchewan (The Noxious Weeds Designation Regulations, 1999) and in the rest of Canada as a secondary noxious weed (Canada Seeds Act 1986 and 2005: Weed Classes), although it is grown commercially in California as a cut flower (Koike *et al.*, 1999). This plant grows in areas of fine textured soils, but it is also commonly found in cultivated fields, waste places and roadsides. The leaves are opposite, 2-8 cm long, smooth, sessile, and blue to green in colour. The flowers, smaller than those of *S. officinalis*, have 5 petals united to form a calyx, funnel-shaped, pale red

to deep pink, and loosely grouped at the ends of stems (Fig. 1.5b). It is a prolific producer of seeds. These are rough, black, nearly round, 2.5 mm in diameter, and enclosed in a capsule. Besides saponins (2-4%), the seed contains protein (12-15%); oil (3-4%) and starch (65-70%) (Mazza *et al.*, 1992; Plants for a future: *Vaccaria hispanica* Database).



Figure 1.5. *Saponaria vaccaria* L. (cow cockle).

1.3.2. Traditional and medicinal uses of *Saponaria vaccaria* L.

The seeds have been used in Traditional Chinese Medicine (Wang Bu Liu Xing) for pain relief, for promoting menstrual discharge and milk secretion, healing wounds, as diuretics, astringents, and anticancer agents (Washington, 1974; Smith F. P., 1969; Duke and Ayensu, 1985). These properties have been associated with the saponin content. The seed also contains cyclopeptides which possess antibiotic and estrogenic

properties, and the starch found in the seed is potentially valuable in cosmetics and specialty foods. The flowers, leaves, roots and shoots also have similar biological properties (Duke and Ayensu, 1985). The sap of the plant is said to be a febrifuge and tonic (Chopra *et al.*, 1956). It is used in the treatment of long-continued fevers of a low grade type. The plant is used externally to cure itch (Chopra *et al.*, 1956), and a decoction is used to treat skin problems, breast tumors, menstrual problems, deficiency of lactation and sluggish labour (Duke and Ayensu, 1985). It has been used in Chinese herbal medicine (Chinese name ‘Wang-Bu-Liu-Xing’) to activate blood flow, promote milk secretion and in the treatment of amenorrhea and breast infections. All plant parts, especially the seed, contain saponins (Fig. 1.6).

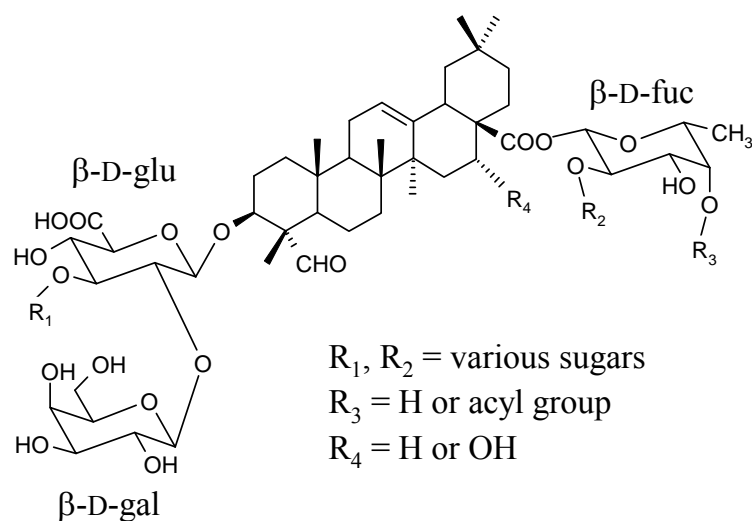

Figure 1.6. Basic structure of the triterpene saponins found in *Saponaria vaccaria* L.

1.4. Bioactive metabolites of *Saponaria vaccaria* L.

In addition to saponins, other bioactive metabolites isolated from the seed of *S. vaccaria* include alkaloids, cyclopeptides, phenolics, and steroids (Sang *et al.*, 2003). Although the processing and properties of cow cockle seed starch have been investigated, research on the bioactive constituents of cow cockle seed has largely been limited to isolation and identification of individual components.

1.4.1. Saponins

Saponins occurring in *S. vaccaria* seeds are glycosides of triterpenes. The main types of saponins correspond to the quillaic acid type and this accounts for approximately 65% of total saponins (Fig. 1.7). Also present are gypsogenin bisdesmosides (~15%) (Fig. 1.8), gypsogenic acid monodesmosides (~10%) (Fig. 1.9), and vaccaric acid bisdesmosides (~10%). Structures of cow cockle saponins are presented in Table 1.1.

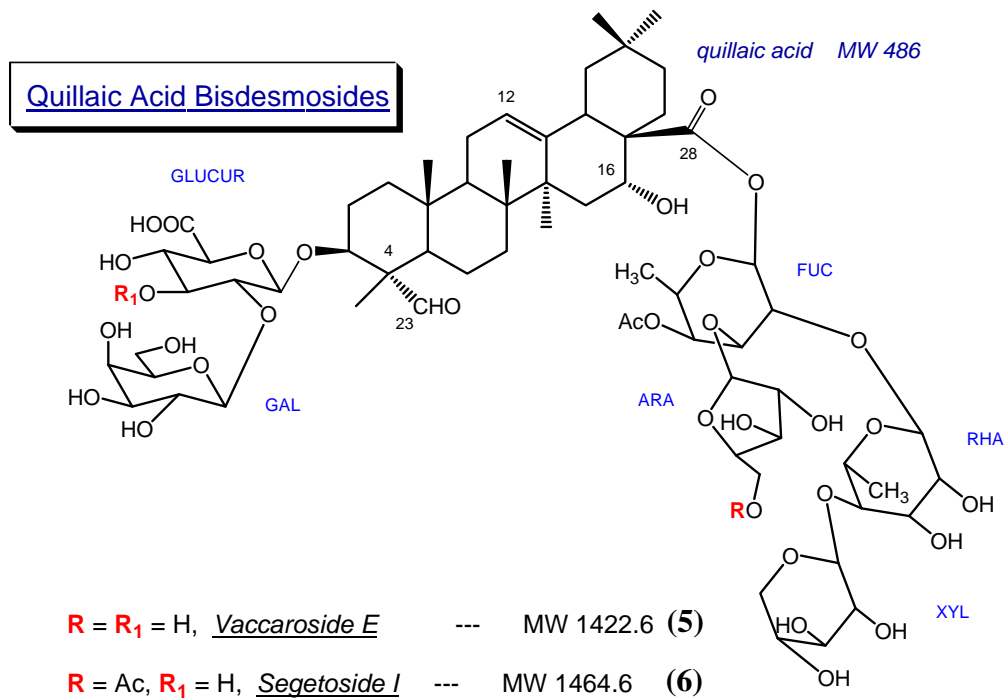

Figure 1.7. Structures of the main quillaic acid bisdesmosides vaccaroside E (5) and segetoside I (6).

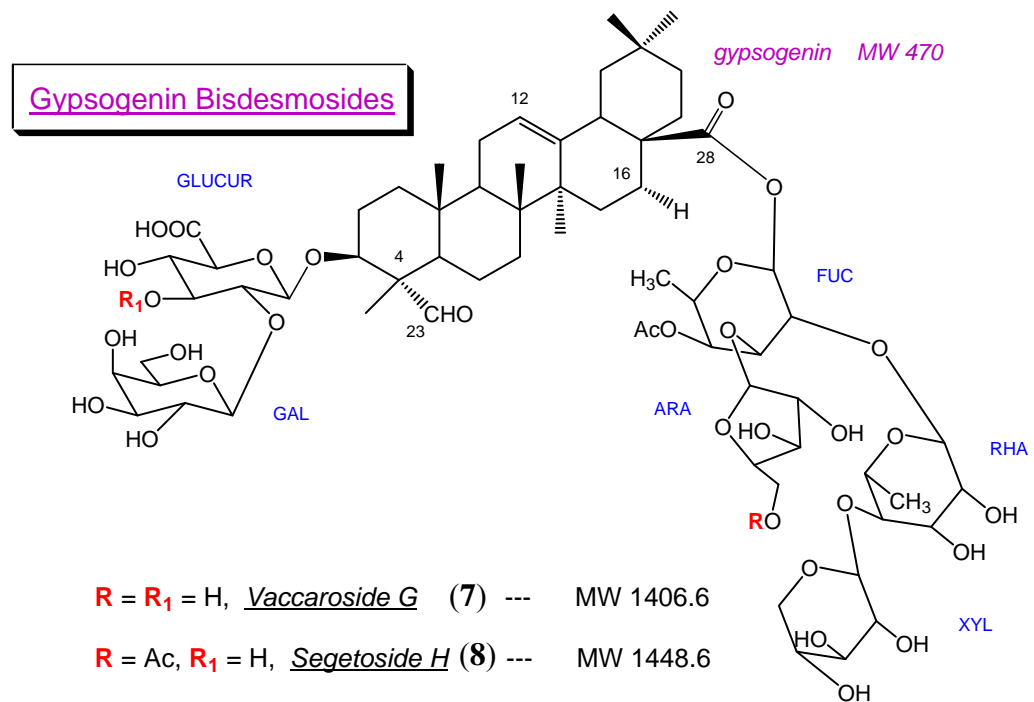

Figure 1.8. Structures of the main gypsogenin type bisdesmosides vaccaroside G (7) and segetoside H (8).

Table 1.1. Saponins isolated from cow cockle seed.

Saponins	Formula	Aglycone	Ref.
Segetosides			
Segetoside B	C ₆₉ H ₁₀₆ O ₃₃	Gypsogenin	<i>Sang et al.</i> , 2002
Segetoside C	C ₅₆ H ₈₈ O ₂₆	Gypsogenic acid	<i>Sang et al.</i> , 1999
Segetoside D	C ₆₉ H ₁₀₆ O ₃₄	Quillaic acid	<i>Sang et al.</i> , 1998
Segetoside E	C ₇₂ H ₁₁₂ O ₃₄	Quillaic acid	<i>Sang et al.</i> , 1998
Segetoside F	C ₆₇ H ₁₀₄ O ₃₂	Gypsogenin	<i>Sang et al.</i> , 2000b
Segetoside G	C ₇₀ H ₁₁₀ O ₃₂	Gypsogenin	<i>Sang et al.</i> , 2000a
Segetoside H	C ₆₈ H ₁₀₄ O ₃₃	Gypsogenin	<i>Sang et al.</i> , 2000a
Segetoside I	C ₆₈ H ₁₀₄ O ₃₄	Quillaic acid	<i>Sang et al.</i> , 2000a
Segetoside K	C ₅₄ H ₈₆ O ₂₆	Olean-12-ene-23 α , 28 β -dioic acid 3 β , 16 α -dihydroxy	<i>Sang et al.</i> , 2000c
Segetoside L	C ₆₀ H ₉₈ O ₂₈	Oleanolic acid	<i>Xia et al.</i> , 2004
Vaccarosides			
Vaccaroside A	C ₅₄ H ₈₆ O ₂₅	Gypsogenic acid	<i>Koike et al.</i> , 1998
Vaccaroside B	C ₆₀ H ₉₄ O ₂₉	Gypsogenic acid	<i>Koike et al.</i> , 1998
Vaccaroside C	C ₅₄ H ₈₆ O ₂₅	Gypsogenic acid	<i>Koike et al.</i> , 1998
Vaccaroside D	C ₅₄ H ₈₆ O ₂₅	3,4-Seco derivative of gypsogenic acid	<i>Koike et al.</i> , 1998
Vaccaroside E	C ₆₆ H ₁₀₂ O ₃₃	Quillaic acid	<i>Jia et al.</i> , 1998
Vaccaroside F	C ₆₅ H ₁₀₂ O ₃₃	Segetalic acid	<i>Jia et al.</i> , 1998
Vaccaroside G	C ₆₆ H ₁₀₂ O ₃₂	Gypsogenin	<i>Jia et al.</i> , 1998
Vaccaroside H	C ₆₅ H ₁₀₂ O ₃₂	Vaccaric acid	<i>Jia et al.</i> , 1998
Vaccaroid A	C ₅₄ H ₈₆ O ₂₅	Gypsogenic acid	<i>Morita et al.</i> , 1997
Vaccaroid B	C ₆₀ H ₉₄ O ₂₉	Gypsogenic acid	<i>Yun et al.</i> , 1997

Note: Table originally published in Glüçlü-Üstlündag *et al.*, 2007.

1.4.2. Cyclopeptides

The seed also contains cyclopeptides which have been reported to possess antibiotic and estrogenic properties. Cyclopeptides represent a group of naturally occurring molecules found in several species of plants and microorganisms. The cyclic nature of these peptides generally affords a greater stability in comparison with corresponding linear peptides. Additional medical and therapeutic applications include anticancer, anti-inflammatory, antithrombosis, antidiuretic and hypotensive activity. Eight cyclopeptides have been isolated from the seeds of *S. vaccaria* (Table 1.2). The structures of segetalin A (**9**) and segetalin B (**10**) are also shown in Fig. 1.10.

Table 1.2. Cyclopeptides identified in cow cockle.*

Compound, MW (obs.)	C	H	N	O	1	2	3	4	5	6	7	8	9
Segetalin A 609.3271	31	43	7	6	gly	val	pro	val	trp	ala			
Segetalin B 484.2433	24	32	6	5	gly	val	ala	trp	ala				
Segetalin C 769.3989	40	51	9	7	gly	leu	his	phe	ala	phe	pro		
Segetalin D 719.3654	37	49	7	8	gly	leu	ser	phe	ala	phe	pro		
Segetalin E 812.4229	43	56	8	8	gly	tyr	val	pro	leu	trp	pro		
Segetalin F 954.4442	44	62	10	14	ala	ser	tyr	ser	ser	lys	pro	phe	ser
Segetalin G 518.2850	25	38	6	6	gly	val	lys	tyr	ala				
Segetalin H 610.2861	29	38	8	7	gly	tyr	arg	phe	ser				

*There is a large variability in the type and amount of cyclopeptides found in different cow cockle accessions.

Segetalin A (cyclohexapeptide), segetalin B (cyclopentapeptide), segetalin C and E (cycloheptapeptides) were first discovered by Itokawa *et al.* (1995), who reported seven cyclopeptides (segetalins A-E, G-H) from this species (Sang *et al.*, 2003). Among these, segetalins A, B, G and H showed estrogen-like activity assayed by the increment of uterus in ovariectomized rats (Yun *et al.*, 1997; Morita *et al.*, 1995). Segetalin F, the largest cyclopeptide found in the seeds of *S. vaccaria*, was first reported by Morita *et al.* in 2006. They also reported the vasodilatory effect stimulated by segetalins A, D, F, G and H against norepinephrine-induced contractions of rat aorta.

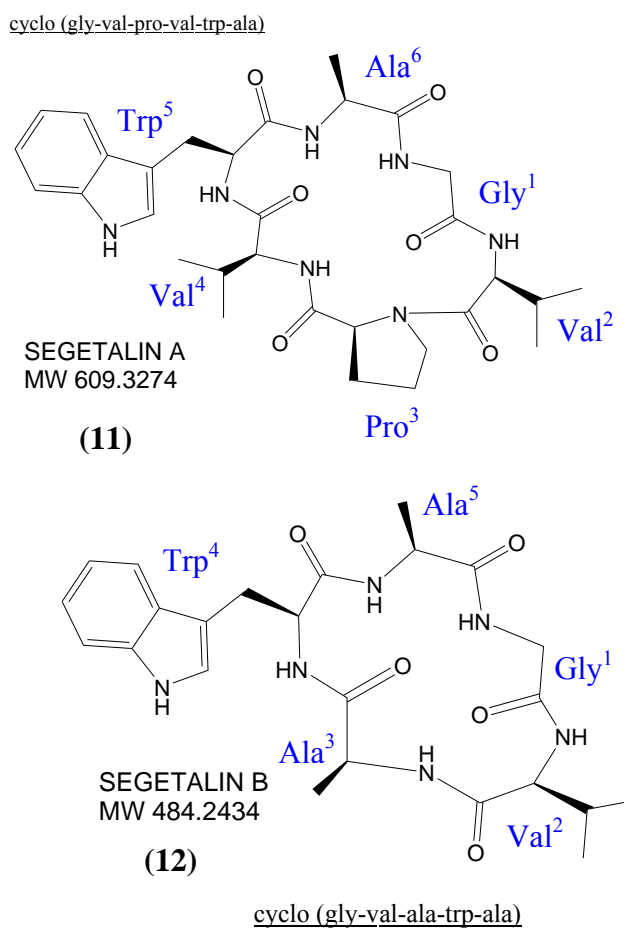

Figure 1.10. Segetalin A (11) and segetalin B (12), a cyclohexapeptide and a cyclopentapeptide isolated from the seeds of *Saponaria vaccaria* L. Glycine is numbered as the first amino acid.

1.4.3. Phenolic acids

Phenolic acids found in the seeds of *S. vaccaria* include the phenylpropanoid glycoside (**13**) and the free phenolic acid dihydroferulic acid (**14**) (Fig. 1.11). These are hydroxylated derivatives of cinnamic acid. The importance of these compounds relates to their potent antioxidative properties and their potential use as protective factors against cancer and heart diseases (Sang *et al*, 2003).

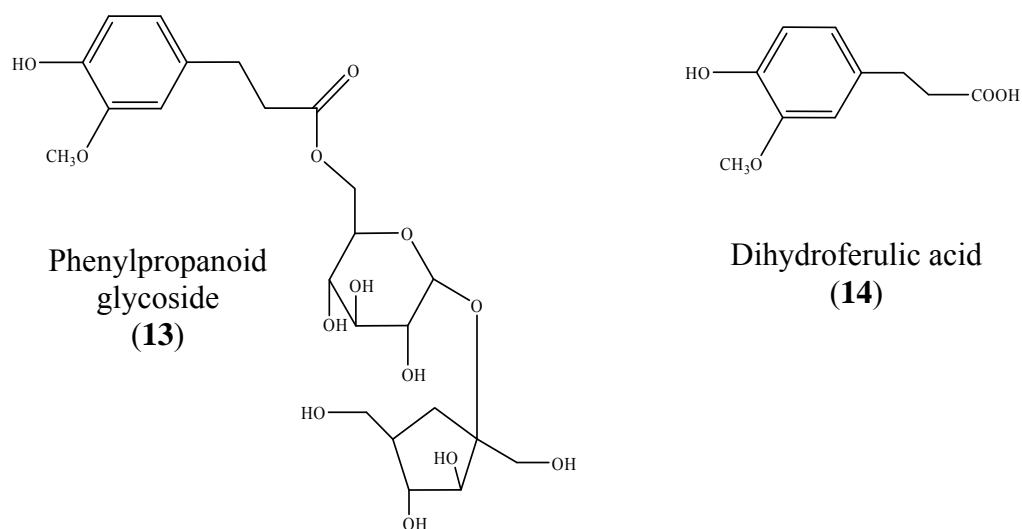
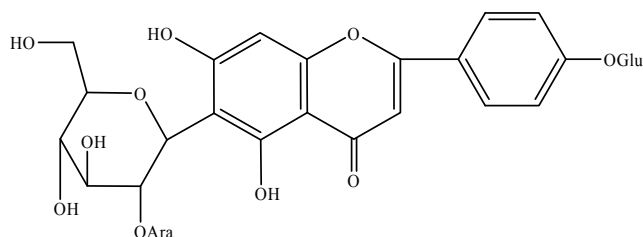

Figure 1.11. Phenolic acids from *Saponaria vaccaria* L.

1.4.4. Flavonoids

Flavonoids are polyphenolic compounds possessing 15 carbon atoms; two benzene rings joined by a linear three carbon chain. Flavonoids have shown many biological and pharmacological activities, such as antioxidant activity, tumor-growth-inhibitory activity in various cancer cell lines *in vitro*, and reducing activity against the risk of breast cancers (Sang *et al.*, 2003). Vaccarin (**15**), a flavone isolated from cow cockle seeds is shown below (Sang *et al.*, 2000d).



Vaccarin (**15**)

1.5. Health benefits of saponins

There have been several reviews in recent years of published reports about various biological properties of saponins (e.g. Glüçlü-Üstlündag and Mazza, 2007; Corea *et al.*, 2005; Francis *et al.*, 2002, Barr *et al.*, 1998; Sen *et al.*, 1998b; Yoshiki *et al.*, 1998; Kensil, 1996; Hostettman and Marston, 1995.).

Saponins function as a "natural antibiotic" for plants and now researchers are testing them for antifungal activity and how saponins may help humans fight infections,

combat microbes and viruses and boost the effectiveness of certain vaccines. The natural tendency to ward off microbes may prove to be especially useful for treating difficult-to-control fungal and yeast infections (Glüçlü-Üstlundağ and Mazza, 2007; Francis *et al.*, 2002; Ferreira and Llodrá, 2000).

Saponins are being researched extensively for cholesterol control. It is hypothesized that the saponins either bind with bile salts or cause the bile salts to bind to the polysaccharides in dietary fiber. Either way the bile salts are unavailable to bind with cholesterol, thus altering cholesterol metabolism (Oakenfull and Topping, 1983 – cited in Joshi *et al.*, 2002). The blood cholesterol-lowering properties of dietary saponins are of particular interest in human nutrition.

Among the most widely known saponins with biological activities are the cardiac glycosides from *Digitalis lanata* Ehrh. and *D. purpurea* L. (Scrophulariaceae) which include digoxin (**16**) and digitoxin (**17**), and the cytotoxic saponin glycyrrhizin (**18**) from *Glycyrrhiza glabra* L. (Leguminosae). Digoxin, the most commonly used preparation of digitalis, is a steroid saponin found in *D. lanata* Ehrh. (foxglove plant) that is used in modern medicine to increase the force of the systolic contractions and prolong duration of the diastolic phase in congestive heart failure. It is also used to help normalize some dysrhythmias (abnormal types of heartbeat). Digitalis drugs lower venous pressure in hypersensitive heart ailments, elevate blood pressure in a weak heart, act as a diuretic, and reduce edema. An exhaustive review published by Rahimtoola and Tak (1996) cited a large number of references and has detailed data and descriptions of a large number of studies and all early trials (Rahimtoola 2004). Digitalis was first prescribed by English physician and botanist William Withering (1741-1799), who used it in the treatment of

edema. In “*An account of the foxglove, and some of its medicinal uses*” he summarized the results of his extensive studies of the drug and described the symptoms of digitalis toxicity (Digitalis 2008).

Glycyrrhizin (**18**) is extracted from liquorice root. It is used to sweeten and flavor many foods and pharmaceutical preparations. There is a long history of its use to treat illnesses such as peptic ulcer (inhibits the enzymes 15-hydroxy-prostaglandin dehydrogenase and delta-13-prostaglandin reductase); colds and other viral infections (may stimulate interferon production; reported expectorant/cough suppressant properties); microbial and parasitic infections (may stimulate the immune system); cancers (again, possibly related to immune system function) (Licorice 2008; Davis and Morris, 1991; Fenwick *et al.*, 1990).

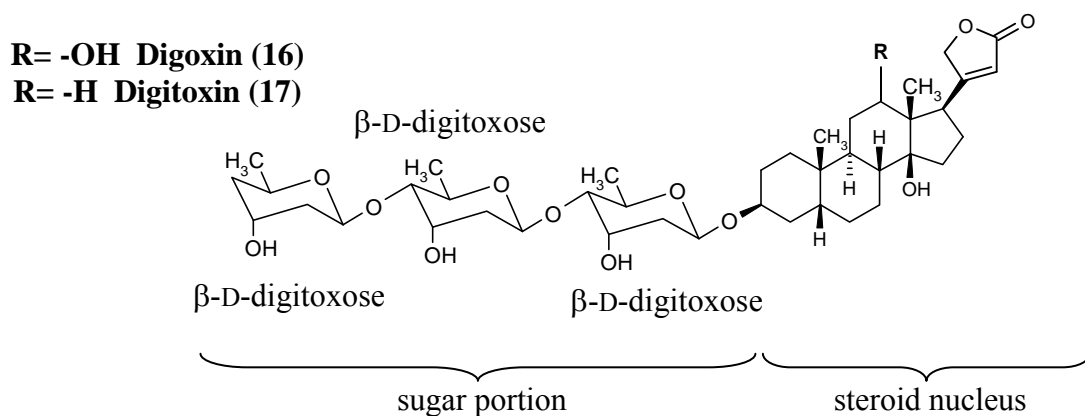

**Glycyrrhizin
(18)**

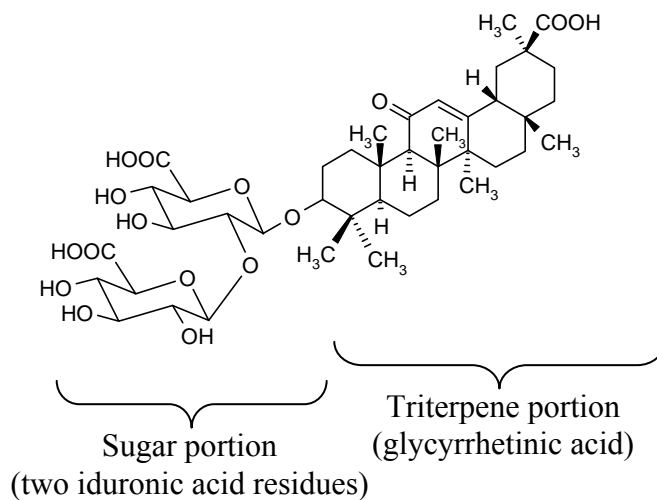

A large number of saponins isolated from both animal and marine species and certain derivatives thereof, have also been tested *in vitro* and *in vivo* for their toxicity against a number of cells and their effectiveness against some tumors. Many laboratories from around the world have focused their interest on the inhibitory and apoptosis-inducing effects of saponins.

1.6. Cancer and Saponins

Advances in the treatment and prevention of cancer require the continuous development of novel and improved chemotherapeutic and chemopreventive agents. Many saponins have been shown in bioassays to be cytotoxic (*in vitro*), anti-tumoral (*in vivo*) and chemopreventive (*in vitro* and *in vivo*) and many of their therapeutic properties and mechanisms of action have been attributed to the diverse sapogenins and the complexity of the sugar chains.

1.6.1. Saponins as a preventive strategy

Studies at the Department of Nutritional Science of the University of Toronto have indicated that dietary sources of saponins offer preferential chemopreventive strategy in lowering the risk of human cancers. At present, damage to normal cells limits cancer therapy. One of the most exciting prospects for saponins is how they appear to inhibit or kill cancer cells since they may be able to do it without killing normal cells in the process. It was found that at the cellular level, saponins inhibit the growth and viability of cancer cells. In animal studies, mice which were fed with saponin-enriched diets and then exposed to colon cancer carcinogens, showed a lower incidence of cancerous and precancerous tumours than the controls. As saponins bind cholesterol, it is believed that they have a natural affinity for binding to cancer cell membranes as these cells have an altered membrane structure with higher amounts of cholesterol-like compounds (Rao and Gurfinkel, 2000; Rao 1997; Rao and Sung, 1995). Specific examples of saponins isolated from diverse sources that have been reported to have important time-dependent anticancer properties include Lee *et al.*, 2006; Kang *et al.*, 2005, Oh and Lee, 2004; Yanamandra *et al.*, 2003; Oh and Sung, 2001.

1.6.2. Saponins as a therapeutic strategy

Numerous reports and review papers on the biological actions and effects of saponins in animal systems have been published in the past few years (Sparg *et al.*, 2004; Francis *et al.*, 2002). Saponins isolated from different plants and animals have been shown to specifically inhibit the growth of cancer cells *in vitro* and *in vivo*.

Depending to the nature of saponins and the cell line studied, cytotoxicities measured as IC₅₀ values range from 4 ng/mL to 20 µg/mL (Lacaille-Dubois 2000).

Avicins, a family of triterpenoid saponins isolated from the Australian desert tree *Acacia victoriae* (Leguminosae) selectively inhibited growth of tumour cell lines by cell cycle arrest in human breast cancer cell line and apoptosis in a leukaemia cell line (Mujoo *et al.*, 2001) and reduced both tumour incidence and multiplicity in a murine skin carcinogenesis model (Hanusek *et al.*, 2001) suggesting that avicins could also suppress the development of human skin cancer and other epithelial malignancies. Haridas *et al.* (2001) also demonstrated that purified avicins, Avicin D and Avicin G, induced apoptosis in the Jurkat human T cell line by affecting mitochondrial function. Several studies on ginsenoside Rg3, a triterpenoid glycoside from *Panax ginseng* (Araliaceae), showed multiple antiproliferative activity of this saponin towards human prostate carcinoma cells including cell cycle arrest at G1 phase and stimulation of apoptosis (Yue *et al.*, 2007). De Tomassi *et al.* (2000) also reported the isolation of antiproliferative triterpene bidesmosidic saponins from the Indian plant *Trevesia palmate* (Araliaceae) against a panel of three cell lines, where the sugar chain esterified at C-28 was crucial for the antiproliferative activity. Structure-activity studies on the accumulation of cisplatin and cytotoxicity in human colon cancer cells by triterpene saponins jennisenosides A, B, C, and D from *Silene jennisensis* (Caryophyllaceae) suggested the importance of the acyl moiety for activity (Gaidi *et al.*, 2002).

Two novel triterpene bidesmosides, designated as enterolosaponin A and B, were isolated from *Enterolobium contotisiliquum* (Leguminosae) and also evaluated for their macrophage-oriented cytotoxic activity. The former exhibited a highly selective

cytotoxicity against BAC1.2F5 mouse macrophages, but the macrophage death caused by this saponin was shown to be neither necrotic nor due to induction of apoptosis from morphology of the dead cells, whose cytosol occurred in vacuolation (Mimaki *et al.*, 2003).

Tubeimoside I and tubeimoside V isolated from tubers of *Bolbostemma paniculatum* (Cucurbitaceae), often used in traditional Chinese medicine for the treatment of tumours as well as for detoxification, showed potent anti-tumorigenic effect in carcinogenesis of mouse skin (Yu *et al.*, 2006) and induction of apoptosis in human glioblastoma cells (Cheng *et al.*, 2006), respectively.

Dioscin, a steroidal saponin isolated from the roots of the Chinese herb *Polygonatum zanlanscianense* (Liliaceae), exerted significant inhibitory effects on the growth of the human leukaemia cell HL-60, inducing differentiation and apoptosis (Wang *et al.*, 2001). Triterpene bisdesmosides saponins securioside A and B from *Securidaca innapendiculata* (Polygalaceae), a plant used in traditional Chinese medicine because of its many bioactivities, showed specific toxic activity against macrophage colony-stimulating factor-induced growth of macrophages. Interestingly, the securiosides seemed to have no or considerably weaker effects against other cells including thymocytes, bone marrow cells and tumour cell lines or even macrophages stimulated by growth factors other than macrophage colony-stimulating factor, revealing a high degree of structure-related specificity. They are believed to be the primary compounds of new drugs for the treatment of pathological states in which macrophage proliferation occurs (Kuroda *et al.*, 2001; Yui *et al.*, 2001).

Dr. Campbell at the University of California, San Francisco screened crude aqueous herbal extracts of seventy-one Chinese medicinal herbs against a panel of five human breast cancer cell lines. Seven of these extracts -including *Saponaria vaccaria*- demonstrated at least 50% growth inhibition on all five cell lines (Campbell *et al.*, 2002). Twelve of the most active extracts were further evaluated against a panel of human and murine cancer cell lines (breast, lung, pancreas and prostate) and the extract of *S. vaccaria* showed very high growth inhibitory activity against all cell lines tested (Shoemaker *et al.*, 2005).

The use of traditional Chinese medicinal herbs as antineoplastic agents as well as the isolation of the active antitumor compounds and the study of their mechanisms of action is an essential tool in the discovery of new leads for the treatment of cancer. There is enough scientific evidence showing that the cytotoxicity and antitumor activity of saponins is by induction of apoptosis.

1.7. Apoptosis. An introduction.

Apoptosis, or programmed cell death, is a normal component of the development and health of multicellular organisms. Cells die in response to a variety of stimuli and during apoptosis they do so in a controlled, regulated fashion. This makes apoptosis distinct from another form of cell death called necrosis in which uncontrolled cell death leads to lysis of cells, inflammatory responses and, potentially, to serious health problems (Wyllie, 1997) (Fig. 1.12). Apoptosis, by contrast, is a process in which cells play an active role in their own death (which is why apoptosis is often referred to as cell

suicide). In the end apoptosis reduces cells to small apoptotic bodies that are swiftly cleared up by phagocytosis (Platt *et al.*, 1999).

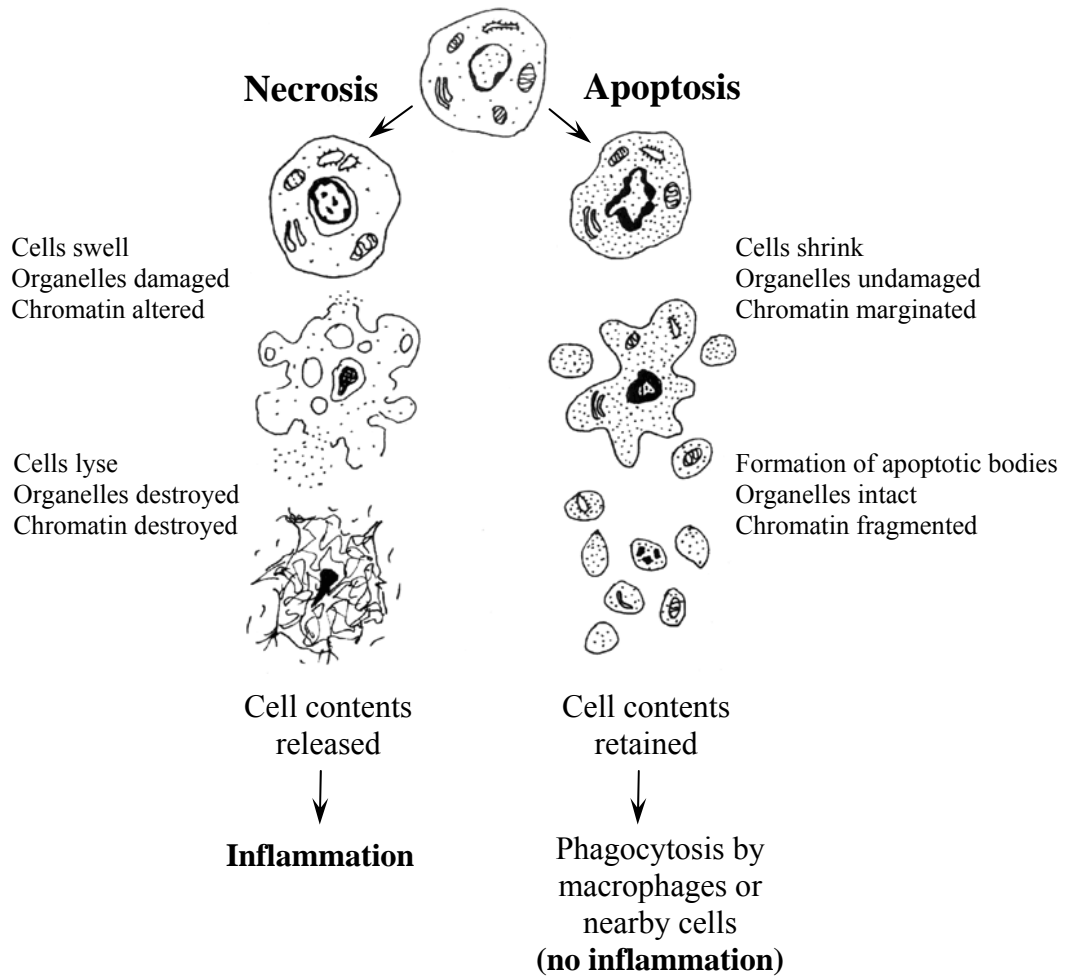

Figure 1.12. Two cell death pathways, necrosis and apoptosis. Necrosis involves breakdown of the cellular membrane, which leads to leakage of intracellular proteins to the extracellular space and subsequently, inflammation. Necrosis usually affects large groups of cells while apoptosis typically involves single cells that undergo organised destruction of the cellular cytoskeleton and formation of apoptotic bodies, which are phagocytosed without an inflammatory reaction.

(Adapted from: <http://escuela.med.puc.cl/pub/PatologiaGeneral/Figuras/fig2.26.gif>)

Apoptosis is a normal cellular process and is essential for the proper development and maintenance of the organism. Apoptosis is also necessary for the destruction of cells considered a threat such as cells infected with viruses, cells with DNA damage, cancerous cells, and cells of the immune system after they have fulfilled their function. (Dales *et al.*, 2001; Wyllie, 1997; Zimmermann and Green 2001).

Apoptosis, in general, confers advantages during an organism's life cycle. For example, the differentiation of fingers and toes in a developing human embryo occurs because cells between the fingers apoptose; the result is that the digits separate. Between 50 and 70 billion cells die each day due to apoptosis in the average human adult. Unregulated apoptosis could exacerbate or cause diseases such as:

- AIDS, in which T helper cell numbers plummet. Part of the dramatic decline in these cells might be caused by healthy T helper cells being tricked into committing suicide;
- neurodegenerative diseases like Alzheimers;
- ischemic stroke, when restricted blood flow to certain regions of the brain can lead to neural death through increased apoptosis;
- cancer, in which tumor cells lose their ability to undergo apoptosis;
- autoimmune disease, in which self-reactive immune cells trick normal body cells to kill themselves;
- viral disease

(Jakubowski 2008).

Apoptosis has been a target of intensive research in recent years. This is reflected by over 140,000 publications to date with the great majority of them published during the last decade (PubMed search, January 2008).

Apoptosis involves a biochemical cascade including such proteins as Bcl-2, Bax, Apaf-1 or apoptotic protease activating factor-1, caspases such as caspase-9, caspase-3, and caspase-7, as well as proteins involved in digestion of proteins, degradation of DNA, and phagocytosis (Fig. 1.13).

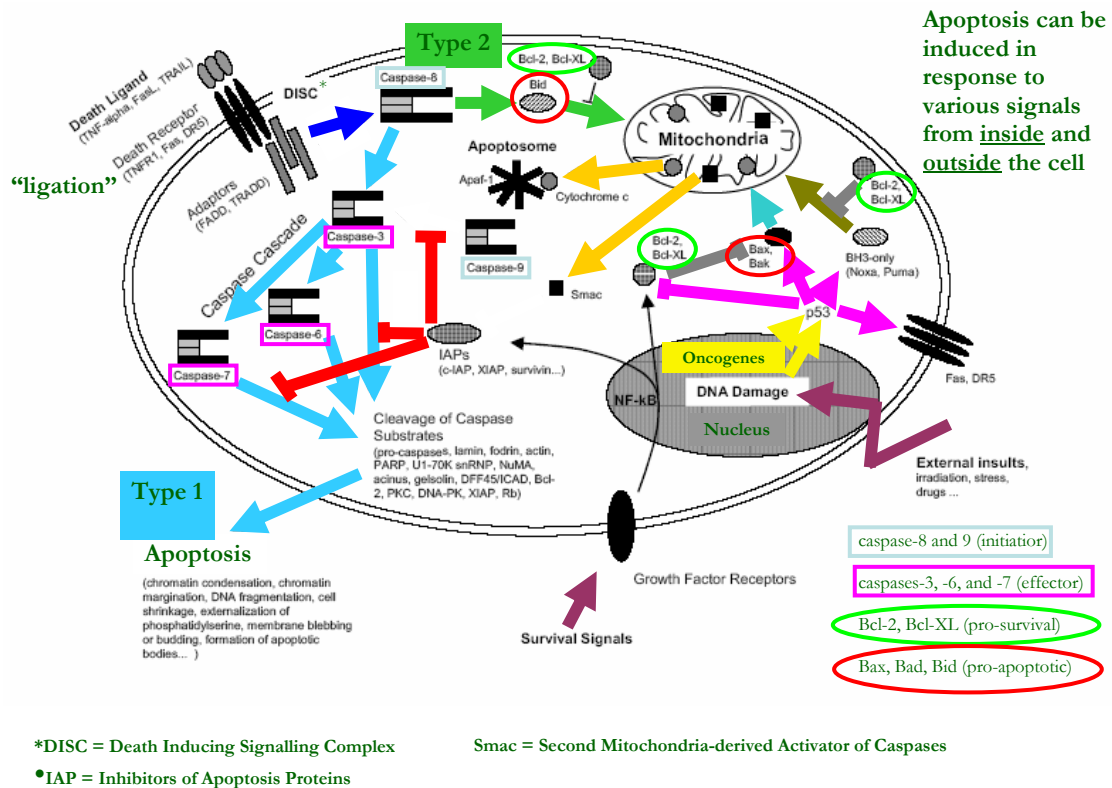

Figure 1.13. Schematic representation of some major apoptotic signalling pathways. (Adapted from: http://www.celldeath.de/encyclo/aporev/revfigs/revfig_6.htm)

1.7.1. Causes of apoptosis

A wide variety of stimuli are capable of inducing apoptosis. Some are universal and can produce apoptosis in almost any cell, while most apoptosis-inducing factors show some selection of their targets (Rich *et al.*, 2000). The decision of a cell to undergo apoptosis depends upon the balance between positive signals keeping the cell alive (e.g., growth factors and interleukins such as IL-2) and negative signals that call for cellular suicide (e.g., oxidative stress, DNA damage, improper protein folding, and specific molecules such as tumor necrosis factor alpha and beta (TNF- α and TNF- β), and the FAS ligand (FasL) that binds to the Fas receptor, or CD95 (Schulze-Osthoff *et al.*, 1998).

Apoptosis does not require new transcription or translation, suggesting that the molecular machinery required for cell death lay dormant in the cell, and just requires appropriate activation. These signals can be internal, external or an apoptosis-inducing factor (Wajant, 2002; Schulze-Osthoff *et al.*, 1998).

Internal signals.

Internal damage to a cell such as that produced by oxidative damage, causes Bcl-2 to activate Bax which creates holes in the mitochondrial membrane. These holes allow the entry of cytochrome c into the cytoplasm. Cytochrome c binds to APAf-1 forming complexes that aggregate to form apoptosomes. This aggregation requires energy from ATP. The apoptosomes activate caspase-9. Caspase-9 cleaves and activates caspase-3 and caspase-7. These executioner caspases activate a cascade of proteolytic activity that

leads to the digestion of structural proteins, DNA degradation, and ultimately phagocytosis (Zhang *et al.*, 2004/2005).

External signals.

FasL and TNF- α/β can bind to the cell membrane receptors Fas and TNF, respectively. Binding of the Fas or TNF ligands results in the activation of caspase-8 which unleashes a proteolytic cascade similar to that activated by caspase-9. This cascade results in phagocytosis of the cell. An example of this process is when cytotoxic T cells bind to a target cell. The T cells produce more FasL that binds to the Fas receptor on the target cell leading to apoptosis of the target cell (Wajant, 2002).

Apoptosis-inducing factor (AIF).

This apoptosis pathway is more common in neurons and is a caspase-independent process. AIF is normally present in the intermembrane space of mitochondria. When AIF is released from the mitochondria, it migrates to the cell nucleus, binds to DNA, and triggers DNA degradation and ultimately cell death (Baehrecke, 2002).

1.7.2. Apoptosis and cancer

Research to date has shown that apoptosis is a phylogenetically conserved form of cell death that is intricately and precisely regulated inside the cell by gene products. Malfunctions of any aspect of this death machinery may directly result in various diseases. Cancer, for example, may be viewed as a result of ineffective apoptosis and hence a net gain of cells due to unrestrained proliferation. On the other hand, cancer

cells themselves may evade immune surveillance by triggering apoptosis of patrolling immune cells (Zhang *et al.*, 2004/2005).

Some viruses associated with cancers use tricks to prevent apoptosis of the cells they have transformed. Several human papilloma viruses (HPV) have been implicated in causing cervical cancer. One of them produces a protein (E6) that binds and inactivates the apoptosis promoter p53 (Tungteakkhun and Duerksen-Hughes, 2008). Epstein-Barr Virus (EBV), the cause of mononucleosis and associated with some lymphomas produces a protein similar to Bcl-2 and another protein that causes the cell to increase its own production of Bcl-2. Both these actions make the cell more resistant to apoptosis (thus enabling a cancer cell to continue to proliferate) (Cuconati and White, 2002; Henderson *et al.*, 1993).

Even cancer cells produced without the participation of viruses may have tricks to avoid apoptosis. Some B-cell leukemias and lymphomas express high levels of Bcl-2, thus blocking apoptotic signals they may receive. The high levels result from a translocation of the Bcl-2 gene into an enhancer region for antibody production (Israels and Israels, 1999). Melanoma (the most dangerous type of skin cancer) cells avoid apoptosis by inhibiting the expression of the gene encoding Apaf-1 (Soengas *et al.*, 2001). Some cancer cells, especially lung and colon cancer cells, secrete elevated levels of a soluble "decoy" molecule that binds to FasL, plugging it up so it cannot bind Fas. Thus, cytotoxic T cells (CTL) cannot kill the cancer cells by the mechanism shown above (Pitti *et al.*, 1998). Other cancer cells express high levels of FasL, and can kill any cytotoxic T cells (CTL) that try to kill them because CTL also express Fas (but are

protected from their own FasL) (Ma *et al.*, 2005, Houston and O'Connell, 2004;
<http://biology-pages.info> Sep. 2007).

CHAPTER 2 HYPOTHESIS AND OBJECTIVES

HYPOTHESIS

Recent studies with saponins from diverse sources indicate that the cytotoxic activity shown against many types of malignant cells occurs through stimulation of apoptosis. **Therefore it is postulated that:**

- 1) Saponins have potential anticancer activity and that this effect occurs in a concentration- and time- dependent manner.**

- 2) *Saponaria vaccaria* saponins induce apoptosis.**

- 3) *S. vaccaria* can be used as sustained source of saponins for the study and development of these compounds as a new class of drug for the treatment of cancer.**

OBJECTIVES

Main objective: To investigate the biological activities of *Saponaria vaccaria* L. seed components particularly for their antitumor effects

1. To grow sufficient amounts of *Saponaria vaccaria* to provide the material for extracts to be tested
2. To prepare extracts from *Saponaria vaccaria* seed, and to test these extracts for cytotoxic activity in a panel consisting of different types of human tumor cells (WiDr, colon; MDA-MB-231, breast; NCI-417, lung; PC-3, prostate) and a human non-malignant cell line (CRL-2522, fibroblast) used as a control
3. To fractionate extracts, evaluate their cytotoxicity and elucidate the chemical composition of the extracts
4. To test partially-purified saponins and other components of the seed
5. To evaluate structure activity-relationships by chemical modifications of the saponin structures
6. To examine apoptosis as a potential mechanism of action of *Saponaria vaccaria* saponins

CHAPTER 3 EXPERIMENTAL

3.1. Plant material and saponin extracts

Different varieties of cow cockle seed were obtained for this study. *Saponaria vaccaria* ‘Scott WT’ (wild type) was obtained from Eric Johnson, Agri-Food and Agriculture Canada, Scott Experimental Farm, Scott, Saskatchewan. Seed of *S. vaccaria* cv. ‘Pink Beauty’ (PB) and ‘White Beauty’ (WB) were obtained from CN Seeds Ltd, Pymoor, UK, and the Mongolia variety (MG) was obtained from the USDA Seed Repository.

Four to five rows of each seed variety were hand seeded in the University of Saskatchewan Crop Science plots (5 × 20 ft) in the summer of 2003 and 2004. Seeds were planted 0.50 to 0.75 inch deep at a rate of 3 seeds and spaced 1 ft apart. Plants were organically grown (hand-weeded, no pesticides, indigenous N₂) with minimum irrigation until seedlings were observed. Bulk seed was harvested in the fall.

The herbal extract, Wang-Bu-Liu-Xing (WBLX), was purchased from a mail order supplier, Botanicum Herbs (botanium.com). Quillaja saponin (QS), having saponin content of approximately 25%, was purchased from Sigma.

Seeds (50 mg) were finely ground and extracted with 70% methanol (2 mL). The methanol extracts were then concentrated and a pre-determined amount of these extracts (estimated saponin content of 2-4% by wt) were added to liquid cultures containing the human cancer cell lines WiDr (colon), MDA-MB-231 (breast), and NCI-417 (lung) for

evaluation of their cytotoxic effects. The concentration of extract tested ranged from 50 to 3.13 $\mu\text{g}/\text{mL}$. Cancer cell lines were chosen because of their incidence in humans and the difficulty of treating these tumors with standard chemotherapy.

For comparative purposes, a commercially available crude saponin extract from *Quillaja saponaria* M. (Rosaceae), and from Quinoa (*Chenopodium quinoa* Willd., Chenopodiaceae) were also used.

3.2. Determination of the cytotoxic activity of plant extracts

3.2.1. Cell lines and culture

Four human tumor cell lines were used for screening of cow cockle extracts for cytotoxic activity: WiDr (ATCC # CCL 218) human colon cancer, MDA-MB-231 (ATCC # HTB 26) human breast cancer, NCI-417 (CRL-5809) human lung cancer and PC-3 (ATCC # CRL-1435) human prostate cancer. CRL-2522 human BJ foreskin (normal fibroblasts) was used as control.

Cell lines were initiated from stocks which were cryopreserved in liquid-phase nitrogen. Stock cultures were maintained in RPMI Medium 1640 with L-glutamine supplemented with 10% fetal bovine serum and 1% antibiotic-antimycotic solution. Cells were grown in 20 mL media in T-75 flasks (Falcon) at 37°C in humidified 5% CO₂.

Typically, cells required feeding every 3-4 days and sub-culturing (passaging) once per week. Cells were always fed the day prior to harvest for the MTT experimental procedure.

3.2.2. Sub-culturing (passaging)

Confluent monolayer cultures of WiDr, MDA-MB 231, PC-3 and CRL-2522 were passaged as described below.

Media was completely removed by aspiration with a Pasteur pipette using vacuum suction. A 0.25% trypsin-EDTA solution (1 mL) was added to the culture flask and allowed to spread over the entire monolayer. Excess trypsin was removed by suction. The flask was placed in an incubator (approx. 30 seconds for MDA-MB-231 and 1-2 minutes for WiDr, PC-3 and CRL-2522). Once the cells appeared to have detached from the flask, trypsin was neutralized by adding 10mL of the medium to the flask and pipetting the media repeatedly over the flask bottom surface to ensure all cells were detached. The cell suspension was transferred to a sterile 15mL centrifuge tube and centrifuged for 7 minutes at 300-400 xg (IEC Centra CL2 Benchtop Centrifuge). The supernatant was removed from the cell pellet by suction and the cells were resuspended in 10mL of media. A single cell suspension was obtained by pipetting the cells in and out to prepare appropriate dilutions of the cell suspension:

For WiDr, a 1:50 dilution was generally required: the cell suspension (1mL) is transferred to new centrifuge tube, fresh media (4mL) is added, mixed, and 1mL is then transferred to a new T-75 flask containing 19mL of fresh media.

For MDA-MB-231, a 1:40 dilution was used: the cell suspension (1mL) is transferred to new centrifuge tube, fresh media (3mL) media is added, mixed, and 1mL is then transferred to a new T-75 flask containing 19 mL of fresh media.

PC-3. 1:100 dilution (as described for WiDr).

CRL-2522. A 1:8 dilution was generally used. Cell suspension (2.5mL) was transferred to a new T-75 flask containing 17.5mL of fresh media.

These splits were found to be optimal to allow the cell cultures to be fed every 3-4 days following sub-culturing. Feeding was done by removing media by aspiration with a Pasteur pipette and adding fresh media (20 mL) to the flask. Cell suspensions were sub-cultured once weekly.

Since NCI-417 does not form a monolayer in the flask, but free aggregates in solution, a different methodology was employed in order to get a confluent suspension culture. Sub-culturing was done by transferring media from a T-75 flask containing the cells in suspension to two sterile 15mL centrifuge tubes and centrifuging for 7 minutes at 300-400 xg. The supernatant was removed from the cell pellet by suction and the cells were resuspended in 10mL media. Pellets from the two centrifuge tubes were then combined and triturated to obtain a single cell suspension. Vigorous trituration was required in order to obtain a single cell suspension. A 1:20 dilution was achieved by transferring 1mL of the cell suspension to a new T-75 flask containing 19mL of fresh media. This split was found to be required in order for cultures to be fed 3-4 days following sub-culturing, and sub-cultured once weekly. As cells grew suspended in the culture media, they cells were fed by transferring the cell suspension into two-15mL centrifuge tubes and centrifuging for 7 minutes at 300-400 xg. The supernatant was then removed from the cell pellet by suction and cells were resuspended in 10mL media. Pellets were combined from the two centrifuge tubes and triturated in order to obtain a single cell suspension. The cells were now transferred into a new T-75 flask, added 10mL more media and placed it in the incubator.

3.2.3. Harvest of cells for bioassays

Cultures were always fed the day prior to harvest for the cytotoxic bioassays. In preliminary experiments the number of cells required for seeding into each microwell to obtain the desired absorbance of about 0.300-0.400 was determined by plating cells at different densities. For cell lines WiDr, NCI-417 and CRL-2522, 2,500 cells/well (or 50 μ L of a cell suspension of 0.5×10^5 cells/mL) was chosen. For MDA-MB-231, 5,000 cells/well (or 50 μ L of a cell suspension of 1.0×10^5 cells/mL) were used.

3.2.3.1. Harvesting WiDr, MDA-MB 231, PC-3 and CRL-2522

Harvesting of these cell lines are performed according to the protocol described below.

Media was completely removed from the flask by aspiration with a Pasteur pipette using vacuum suction. A 0.25% trypsin-EDTA solution (1mL) was added to the culture flask and allowed to spread over the entire monolayer. Excess trypsin was removed by suction. The flask was placed in an incubator (approx. 30 seconds for MDA-MB-231 and 1-2 minutes for WiDr, PC-3 and CRL-2522) and once cells appear to have detached from the flask, trypsin was neutralized by adding 10mL medium to the flask and pipetting the media repeatedly over the flask bottom surface to ensure all cells were detached. The cell suspension was then transferred into a sterile 15mL centrifuge tube and centrifuged for 7 minutes at 300-400 xg. The supernatant was removed from the cell pellet by suction; cells were resuspended in 10mL media and triturated to obtain single cell suspension. This was the “stock” cell suspension.

The cell count was done manually using a hemocytometer. Typically, a T-75 flask of WiDr contained approximately 5×10^7 cells and a “stock” cell suspension required 1:20 dilution for the cell count. A T-75 flask of MDA-MB-231 contained approximately 2×10^7 cells and a “stock” cell suspension required 1:10 dilution for the cell count. A T-75 flask of CRL-2522 contained approximately 5×10^6 cells and a “stock” cell suspension required 1:2 dilution for the cell count. Appropriate dilutions from the “stock” cell suspension with media was performed to obtain a “working” cell suspension of 0.5×10^5 cells/mL for WiDr , PC-3 and CRL-2522 or 1.0×10^5 cells/mL suspension for MDA-MB-231.

3.2.3.2. Harvesting NCI-417

The harvesting of the NCI-417 cell line was performed as described below.

Media from a T-75 flask containing the cells in suspension was transferred to two sterile 15mL centrifuge tubes. The tubes were centrifuged for 7 minutes at 300-400 xg. The supernatant was removed from the cell pellet by suction and the cells were resuspended in 10mL media. Pellets from the two centrifuge tubes were combined and triturated to obtain a single cell suspension. Vigorous trituration was required in order to obtain a single cell suspension. The cell count was done manually using a hemocytometer. A T-75 flask of NCI-417 typically contained approximately 5×10^6 cells and no dilution of “stock” cell suspension was required for the cell count. An appropriate dilution of “stock” cell suspension was prepared with the media to obtain a “working” cell suspension of 0.5×10^5 cells/mL.

3.3. Preparation of drug solutions for cytotoxic assay

- Pimozide (MW = 461.56)

Pimozide stock was prepared by dissolving pimozide (110.8mg) in absolute ethanol (100mL). An aliquot (10 μ L) of this solution was added to the first row of wells containing 90 μ L media.

- Ethanol control

Absolute ethanol (10 μ L) was added to first row of wells containing 90 μ L media.

- 5-Fluorouracil (MW = 130.08)

A stock solution "A" was prepared dissolving of 5-fluorouracil (97.56mg) in 0.2N NaOH (5mL). Then 160 μ L of stock "A" were diluted to a total volume of 10.0mL with RPMI media. 10 μ L were added to first row of wells containing 90 μ L media.

- NaOH (0.2N) control (MW = 40.0)

NaOH (0.4g) was dissolved in H₂O (50mL). An aliquot (10 μ L) was added to the first row of wells containing 90 μ L media.

- NaOH (0.2N) control

NaOH (160 μ L, 0.2N) was diluted up to a total volume of 10.0mL with RPMI media. An aliquot (10 μ L) was added to first row of wells containing 90 μ L media.

- **Vinblastine sulfate (MW = 909.1)**

(Testing range 3.75–120 μ m)

Vinblastine sulfate (43.6mg) was dissolved in H₂O (10mL). An aliquot (5 μ L) was added to first row of wells containing 95 μ L media.

- **Vinblastine sulfate (MW = 909.1)**

(Testing range 0.375–12 μ m)

Vinblastine sulfate (4.36mg) was dissolved in H₂O (10mL). An aliquot (5 μ L) was added to first row of wells containing 95 μ L media.

3.4. Preparation of seed extract solutions

Seeds were harvested, and cleaned from debris. Seeds (1 g) were finely ground and extracted with 25 mL of aqueous methanol (70%) in an IKA[®] T25 basic Ultra Turrax[®] homogenizer. The methanol (MeOH) extract was centrifuged for 5-10 min at 300-400 xg and the supernatant was set aside. The pellet was resuspended in 70% MeOH containing 0.2% ammonium acetate, centrifuged, and the supernatant was pooled with the previous one. The combined extract was evaporated and the residue was transferred into a pre-weighed vial. The weight was recorded.

The dried crude extract was then dissolved in water (2mL) and sonicated. The suspension was loaded into a C₁₈ Sep-Pak cartridge (1 g), and four different fractions were eluted as follows:

Fraction 1: 100% H₂O (10 mL)

Fraction 2: 30% MeOH (10 mL)

Fraction 3: 70% MeOH (10 mL)

Fraction 4: 100% MeOH (10 mL)

All fractions were evaporated until dryness using a Büchi Rotavapor–R and weighed. All fractions were analysed by HPLC-PDA-MS and an aliquot of the saponin-containing fraction 3 (5mg) was dissolved in DMSO (0.1mL) and RPMI medium (4.9mL) without FBS and an antibiotic-antimycotic solution to yield a stock solution of 1 mg seed extract / mL medium. The stock solution was used for cytotoxic evaluation against the above described cancer cells using the cell proliferation “MTT” bioassay.

3.5. Cell proliferation assay “MTT” (*in vitro* bioassay)

3.5.1. Standard CellTiter 96[®] assay protocol for 96-well plates

The anticancer activity of the extracts was evaluated using the CellTiter 96[®] non-radioactive cell proliferation assay (Fig. 3.1). The CellTiter 96[®] assay is based on the cellular conversion of a tetrazolium salt into a formazan product that is easily detected using a 96-well plate reader. The assay is performed by the addition of a premixed optimized Dye Solution to culture wells of a 96-well plate containing various concentrations of test substance to be measured. During 4-hour incubation, living cells reduce the soluble yellow tetrazolium component of the Dye Solution (MTT) to insoluble purple formazan crystals (Fig. 3.2). The Solubilization/Stop Solution is then added to the culture wells to solubilize the formazan product and the absorbance at 570nm is recorded using a 96-well plate reader. The intensity of the color absorbance is directly proportional to the level of cell proliferation or viability (Promega Technical Bulletin No. 112, 1999; Pagé, 1997; Sieuwerts *et al.*, 1995).

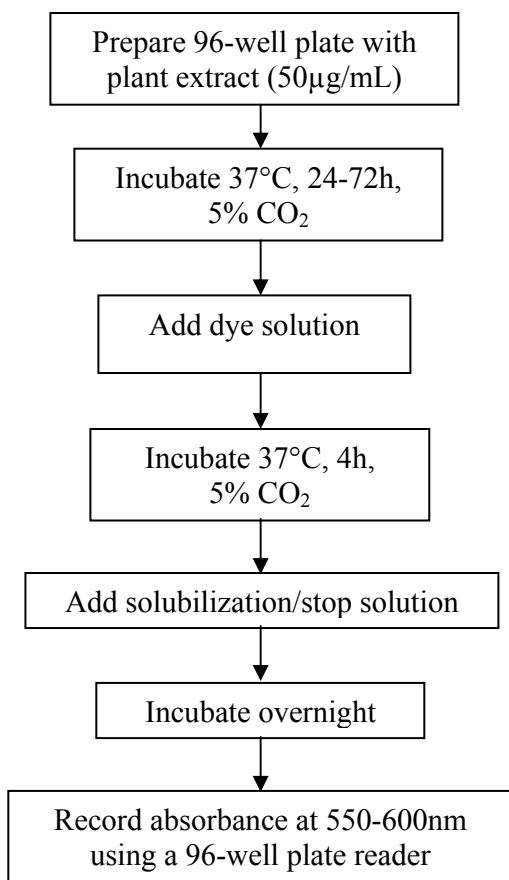

Figure 3.1. CellTiter 96[®] non-radioactive cell proliferation assay flowchart.

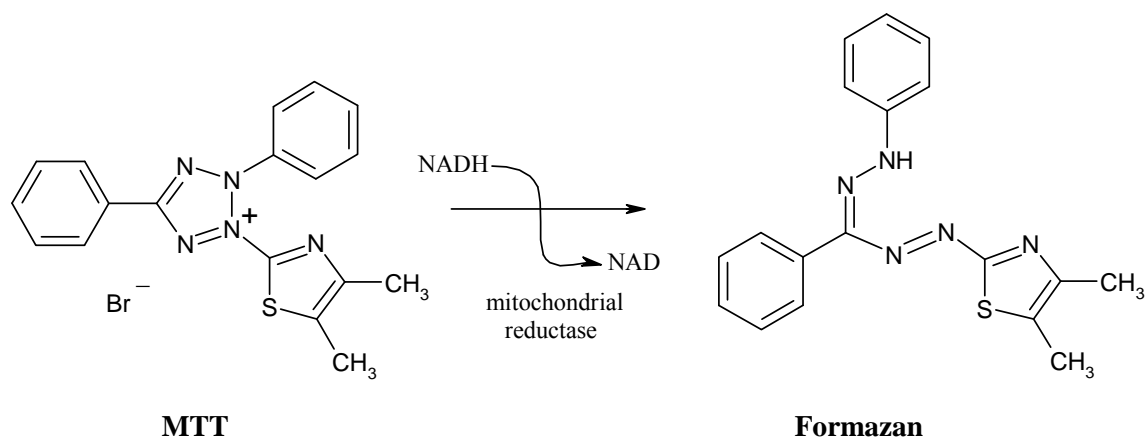

Figure 3.2. Molecular structure of 3-(4,5-dimethylthiazol-2-yl)-2,5-diphenyl-tetrazolium bromide (MTT) and its corresponding reaction product (formazan).

3.6. Preparation of assay plates for determination of IC₅₀ values

Each drug or seed extract was analyzed in triplicate in a bioassay and each bioassay was performed a minimum of two times. The cytotoxic activities were evaluated at concentrations of 50, 25, 12.5, 6.25, 3.125 and 1.5625 µg/mL using the cell lines. Ninety microlitres (90 µL) of the assay medium was added into wells that contained the highest concentration of plant extract tested (row A). Also 100 µL of medium was added into the blank control (row H, columns 1-6), and 50 µL to negative control wells (row F, columns 1-6) and the remaining wells. The first concentration of 50 µg/mL was prepared by addition of 10 µL of the test extract solution into the first row of wells. Using a multichannel pipettor, 50 µL two-fold serial dilutions for the extracts across the well plate were performed (Fig. 3.3).

3.7. Color development and data recording

Dye solution (15 µL) was added to each well, and the plate incubated at 37°C for 4 h in a humidified 5% CO₂ atmosphere. After 4h, Solubilization/Stop Solution (100 µL) was added to each well. The plate was allowed to stand overnight in a sealed container with a humidified atmosphere at room temperature to completely solubilize formazan crystals prior to data recording. The absorbance at 570nm was recorded using a 96-well microplate reader (ThermoLab System Multiskan Spectrum Microplate Spectrophotometer).

		Extract 1			Extract 2			Extract 3			Extract 4		
		1	2	3	4	5	6	7	8	9	10	11	12
Final Concentration													
50µg/mL	A												
25µg/mL	B												
12.5µg/mL	C												
6.25µg/mL	D												
3.13µg/mL	E												
1.57µg/mL	F												
Negative control	G							Plate 1 WiDr					
Blank control	H												

Take 50µL
Discard 50µL

Figure 3.3. Two-Fold serial dilution for plant extracts at six different concentrations in a 96-well plate.

3.8. Data calculation

3.8.1. Percentage mortality

The growth ratio of cancer cells under different concentrations of each plant extract was calculated by the following formula:

$$Y (\%) = (1 - T / C) \times 100$$

Where: Y = Growth ratio of cancer cell mortality at each sample concentration

T = Mean absorbance of treated cells

C = Mean absorbance of negative control

3.8.2. Calculation of IC₅₀ values

Optical density (OD) values were plotted against the logarithmic values of the concentrations. The corresponding half value of the negative control (NC) is then extrapolated. Example: if the corrected absorbance value for the NC is 0.156, half of this is 0.078 (0.156/2=0.078). This means conversion of MTT to formazan if only half of the total number of cells in the NC was alive **OR** half were dead). The corresponding value to this log concentration is then calculated. An example is shown in Fig. 3.4.

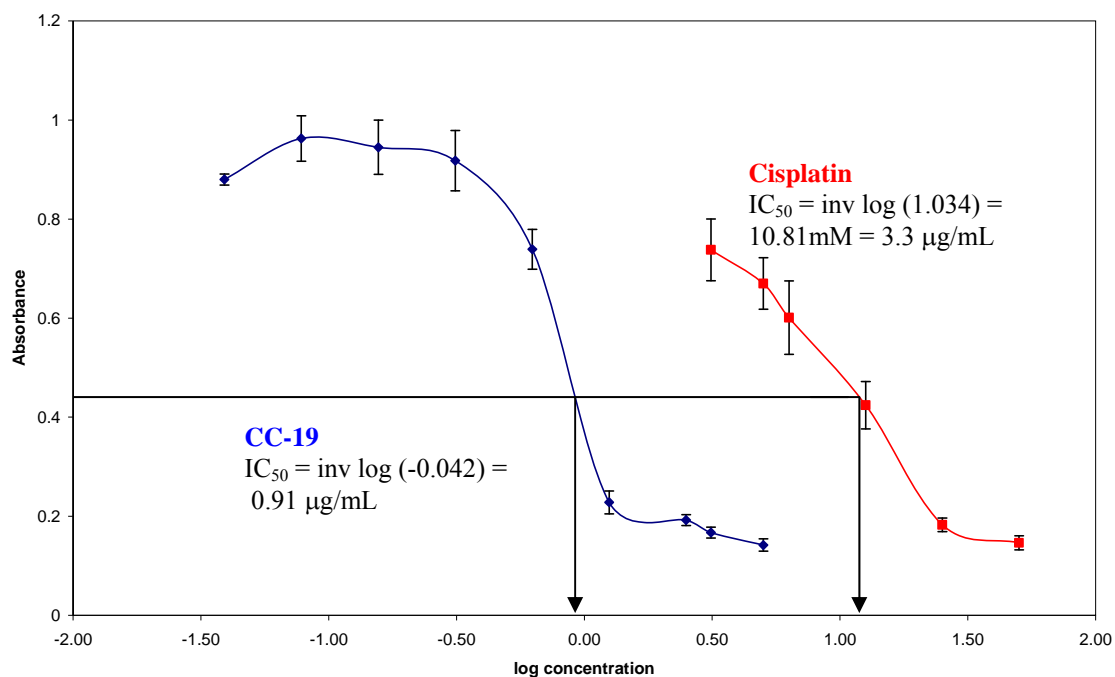

Figure 3.4. IC₅₀ comparison of saponin-containing fraction CC-19 and cisplatin on human breast cancer cell line MDA-MB-231.

3.9. Preparation of seed material and chromatographic separations

3.9.1. Materials

All solvents used for the extraction of seed and fractionation and purification of extracts were purchased from BDH Inc. (Toronto, Ont., Canada) or E. Merck (Darmstadt, Germany). All solvents were of analytical grade and used without further purification. Acetonitrile used for HPLC analysis was HPLC grade.

3.9.2. Fractionation of saponin extracts by reverse phase column chromatography (RPCC) using gradient elution

The following protocol was designed and performed by Dr. John Balsevich (NRC-PBI). *Saponaria vaccaria* L. seed (200g) was treated with 100 mL water for 3 days. The seeds were removed from the water and ground up with 90% aqueous methanol (MeOH). The solids were removed by centrifugation and the extract defatted with hexane (Hex). The Hex extract was discarded and the MeOH extract concentrated *in vacuo* to approximately 100 mL. Concentrate was applied to glass column (2 cm i.d.) containing 100 g Supelco Discovery DSC-18Lt reverse phase packing which had been equilibrated in water for a few hours. After the column was packed, 50-100 mL fractions were collected from a gradient system starting from 0 to 100% MeOH in 5% increments of MeOH.

3.9.3. Fractionation of saponin extracts by column chromatography (CC) using an isocratic elution system

A larger chromatographic separation by gravity column using a divinylbenzene polymer as stationary phase (Amberchrome resin CG-300S) was performed with 15 g of

saponin mixture (SPM). SPM was provided by Dr. J. Balsevich (NRC-PBI) from a different large scale fractionation of the methanolic extract of cow cockle seeds. A mixture of methanol:water:acetic acid [MeOH:H₂O:CH₃COOH (80:20:0.01)] was used as the mobile phase (isocratic). Twenty two fractions (100 mL each) were collected from the column (CC-1 to CC-22) and aliquots were analyzed by HPLC-PAD-MS.

3.9.4. Purification of cyclopeptides from the seed of *S. vaccaria* L.

Cyclopeptide containing fraction ‘CP A,B,D+’ was obtained from the 70% MeOH extract of the seeds of cow cockle as follows: an aqueous concentrate of the dry MeOH extract was extracted with ethyl acetate (EtOAc, 2×) and the EtOAc soluble fraction separated and evaporated to dryness. The dry residue was then re-suspended in diethyl ether (Et₂O) to eliminate non-polar impurities, and the Et₂O insoluble fraction was labelled as ‘CP A,B,D+’. A diagram of the extraction procedure is shown below (Fig. 3.5).

3.9.5. Fractionation by vacuum liquid chromatography (VLC) using gradient elution

Vacuum liquid chromatography of cyclopeptide-enriched fraction (CP A,B,D+) was performed according to Pelletier *et al.* (1986). The adsorbent silica-gel (Type H, size 10-40μ) purchased from Sigma Chemical Co. (St. Louis, MO., USA) was first loaded into a glass funnel and allowed to settle by gentle tapping. The vacuum was then applied, and the adsorbent was compressed to a hard layer by pressing with a rubber stopper and tapping.

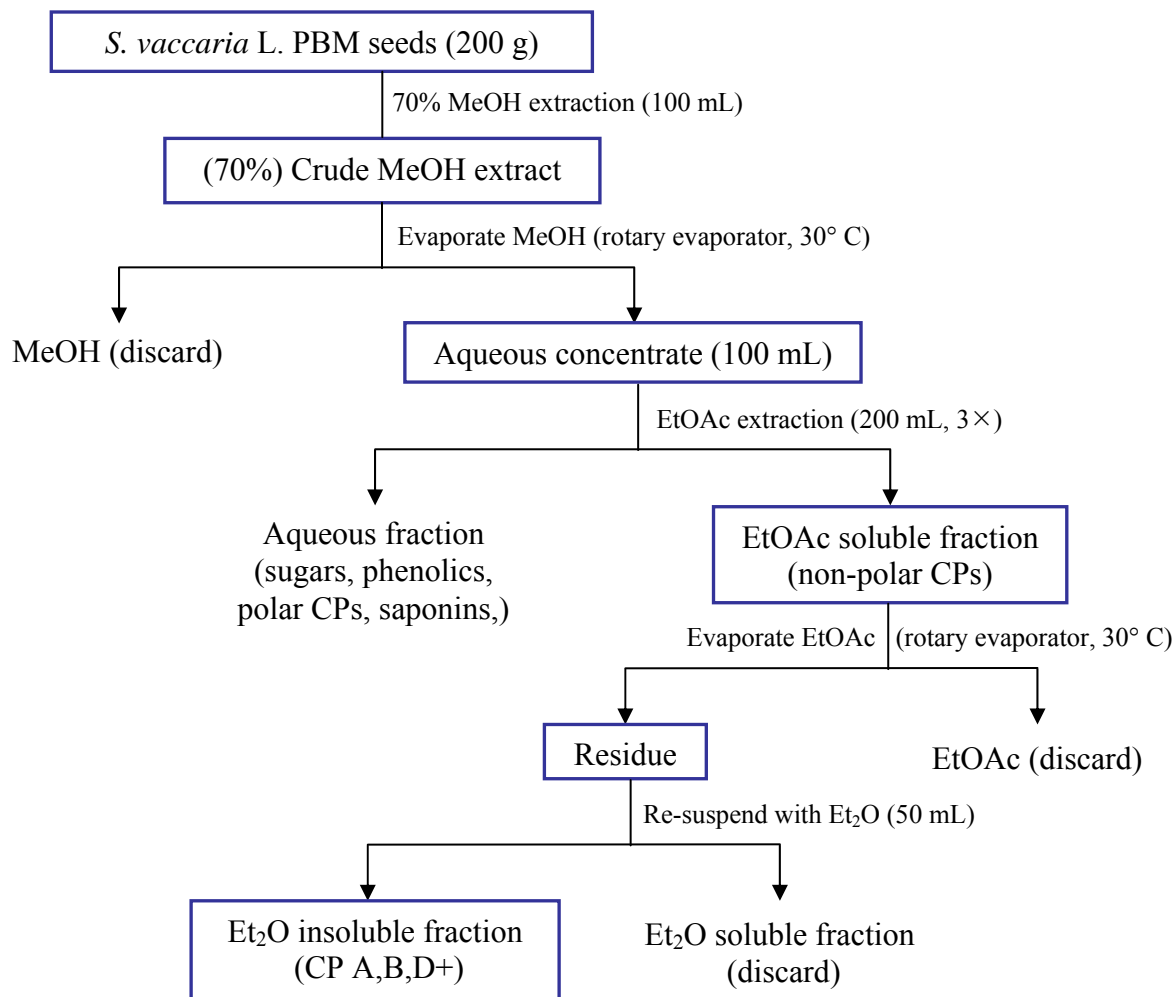

Figure 3.5. Separation of cyclopeptide-containing fraction ‘CP A,B,D+’ from the methanol extract of the seeds of cow cockle.

Once uniform and tight packing of the adsorbent was achieved, the vacuum was released, the solvent of lowest polarity (ethyl acetate) poured quickly onto the adsorbent surface and the vacuum reapplied. The column was then sucked dry and the cyclopeptide fraction preadsorbed on silica-gel (1:3 ratio) was carefully introduced onto the surface of the packing (no vacuum). Enough solvent was used to completely cover

the top surface of the packing and vacuum applied gently to draw the sample into the packing. A solvent mixture consisting of EtOAc:acetic acid/water (1:1) was used as the starting mobile phase. Fifteen fractions (100 ml) were collected each time reducing the amount of EtOAc by 4.16% while keeping the acetic acid/water (1:1) constant. The last concentration used was 5:1.

3.9.6. Analytical thin layer chromatography (TLC)

Analytical thin layer chromatography was carried out on aluminum - backed plates of silica gel 60 F₂₅₄ (5 x 10 cm, 0.25 mm layer thickness; E. Merck, Darmstadt, Germany) and after elution with a suitable solvent system, examined under UV light (254/366 nm). The plates were sprayed with 1% (w/v) vanillin-H₂SO₄ reagent (V-S, staining solution) (Wagner *et al.*, 1984). Compounds were visualized after color development upon heating at 110°C for 2 min. The developing solvent system consisted of a mixture of EtOAc, acetic acid and water (9:0.5:0.5).

3.9.7. Purification by preparative thin layer chromatography (PTLC)

Preparative thin layer chromatography of target fractions was performed on silica gel plates (EM, 60 F₂₅₄, 20 cm × 20 cm, 0.25 mm thickness). Generally, the fraction was dissolved in the minimum amount of the selected developing solvent system and applied to the plate. The plate was developed, air-dried and observed under the UV light. The developed bands were scraped from the plate with the aid of a scraping knife and compounds were recovered from silica by repeated washes with the

solvent system. The solvent system used for the separation of cyclopeptides by PTLC consisted of a mixture of EtOAc, acetic acid and water (9:0.5:0.5), developed 2-4 times.

3.9.8. High performance Liquid Chromatography-Photo Diode Array Detection-Mass Spectroscopy (HPLC-PDA-MS) analysis

HPLC analyses were performed by Mr. Greg Bishop (NRC-PBI) using a Waters Alliance 2695 chromatography system with inline degasser, coupled to a ZQ 2000 mass detector and a 2996 PDA, was used for analyses. Waters MassLynx v. 4.0 software was used for data acquisition and manipulation. The columns used were a Waters Symmetry RP C18 (150 × 2.1 mm i.d.; 3.5 μm), a Waters Sunfire RP C18 (150 × 2.1 mm i.d.; 3.5 μm) or a Phenomenex (Torrance, CA, USA) Synergi MAX-RP 80A C12 (250 × 2.0 mm i.d.; 4 μm). The flow rate with the Waters columns was 0.2 mL/min, and with the Phenomenex column 0.15 mL/min. Columns were maintained at 35°C during runs. The binary solvent systems used were with solvent A, 0.12% acetic acid in 10% acetonitrile (aq., v/v), and solvent B, 0.12% acetic acid in 100% acetonitrile. Gradients used were: (1) 0–3 min, 75% A–25% B; 3–25 min, 75% A–25% B to 50% A–50% B; 25–28 min, 25% A–75% B to 100% B; 28–33 min, 100% B; and (2) 0–8 min, 90% A–10% B; 8–31 min, 90% A–10% B to 50% A–50% B; 31–33 min, 50% A–50% B to 100% B; 33–48 min, 100% B. Injection volumes of 5 μL were typical.

Unless otherwise noted, the mass detector parameters (ESI–) were set to capillary (kV) 2.70, cone (V) –30 to –90.0 over a mass range of 400–1900, extractor (V) –3.50 and RF lens (V) –0.7. PAD was performed over the range 200–400 nm, and saponins were monitored at 209 nm.

3.10. Stimulation of apoptosis using flow cytometry

Flow cytometry was performed at the University of Saskatchewan Cancer Centre Research Unit. Ms. Leah Deibert (NRC-PBI) performed assays as described below.

Three assays were used to determine if Segetoside H (MW 1448) could induce apoptosis in PC-3 and MDA-MB-231 cells: Dual Sensor: MitoCaspTM (Cell Technology), Vybrant® Apoptosis Assay Kit #2 (Molecular ProbesTM), and APO LOGIXTM Carboxyfluorescein Caspase 9 Detection Kit (Cell Technology). PC-3 cells were seeded in tissue culture flasks with regular growth medium and maintained under normal conditions. After cells had adhered, the tissue culture medium was replaced with medium containing Segetoside H dissolved in DMSO with the final concentration of DMSO not exceeding 0.05%. For each assay, a flask of untreated cells was grown in media containing the same amount of DMSO as in the Segetoside H treated samples. Following incubation under normal growth conditions for the specified time, cells were washed once with cold phosphate-buffered saline (PBS) (137 mM NaCl, 2.7 mM KCl, 4.3 mM Na₂HPO₄·7H₂O, 1.4 mM KH₂PO₄) and harvested as previously described. Assays were carried out according to instructions given in kits. All flow cytometry was performed using a Coulter Epics XL (Beckman).

Dual Sensor: MitoCaspTM as performed by Ms. L. Deibert.

Following Segetoside H treatment, adherent and non-adherent cells were harvested and washed with cold PBS. Following centrifugation at $500 \times g$ for 5 min, cell pellets were resuspended in PBS at 3.3×10^6 cells/mL. Cell suspension (300 μ L) was mixed with 10 μ L each of $30\times$ Mitochondria Membrane Potential Dye and $30\times$ Caspase 3/7 detection reagent. Following incubation for 60 min under normal growth

conditions, cells were washed twice with 1× wash buffer and resuspended in 0.5 mL 1× wash buffer. Samples were analyzed by flow cytometry measuring the fluorescence emissions from 515 nm to 530 nm for caspase detection, and 574 nm to 600 nm for mitochondrial membrane potential detection.

Samples of purified saponins having MW 1278, 1422, 1464, 1448 and Quinoa saponin were provided by Dr. J. Balsevich (NRC-PBI).

CHAPTER 4 RESULTS AND DISCUSSION

Identification, isolation, structural determination, cytotoxic evaluation and mechanism of action of *S. vaccaria* L. saponins

4.1. Evaluation of the cytotoxic activity of the methanol extracts of seed from four varieties of *Saponaria vaccaria* L. on three human cancer cell lines (WiDr, MDA-MB-231 and NCI-417)

The cytotoxic activity of the methanol extracts from seed of Scott, Pink Beauty (PB), White Beauty (WB) and Mongolia (MG) were analysed in the MTT assay on the human cancer cell lines WiDr, MDA-MB-231 and NCI-417. The activity of commercially available seed extract “Wang Bu Liu Xing”, Quillaja saponin (QS) and Quinoa were also evaluated for comparative purposes. There was a dose-dependent reduction in saponin-induced cell killing, showing 100% cell death at the highest concentration tested (50 µg/mL). Figure 4.1 shows data for the methanol extract from seeds of the four *S. vaccaria* varieties. The highest sensitivity was observed with the human colon cancer cell line WiDr, and the extract from the Scott WT variety showed higher cytotoxicity when compared with those from PB, WB and MG. A similar response was observed with the extracts from WBLX and QS (Fig. 4.2). Quinoa extract did not show any activity. When the dose-response curves generated from all extracts were compared on each cell line individually, the cytotoxicity exerted by the Scott WT

variety on WiDr and MDA-MB-231 was more evident (Fig. 4.3a and 4.3.b). It was also noticed the great variability in responses and minimal differences in cytotoxic activities by the extracts on the human lung cancer cell line NCI-417 (Fig. 4.3.c). The biological activities expressed as IC_{50} values of the seed extracts exerted against the three human cancer cell lines are presented in Tables 4.1, 4.2, and 4.3. These values were calculated from dose response curves generated by computer program MS Excel.

IC_{50} is defined as the concentration of an extract or drug that is required for 50% inhibition of cell growth. A plant extract is regarded as cytotoxic if its IC_{50} value is less than 10 $\mu\text{g/mL}$ (Jackson *et al.*, 2000), and a pure compound is defined as cytotoxic if its IC_{50} value is less than 4 $\mu\text{g/mL}$ (Fiebig *et al.*, 1985). IC_{50} values shown herein were not based on the plant preparation, but on estimated saponin content of extract. The Scott WT variety showed the highest activity followed by the MG variety. PB and WB varieties showed similar results to the commercially available saponin extract. Quillaja saponin showed higher IC_{50} values (less toxic) than cow cockle plants, and quinoa did not show any activity at the highest concentration tested (50 $\mu\text{g/mL}$). It was later learned that the seeds of wild-type Scott variety contains a significantly greater titer of higher molecular weight saponins with a novel 3-*O*-trisaccharide structure, associated with the activities observed (Balsevich *et al.*, 2006).

While the Scott WT variety had the highest toxicity overall, the seed from the PB variety was used for the scale-up extractions due to greater availability and the observation that it contained the same saponins as Scott variety, albeit in different relative amounts.

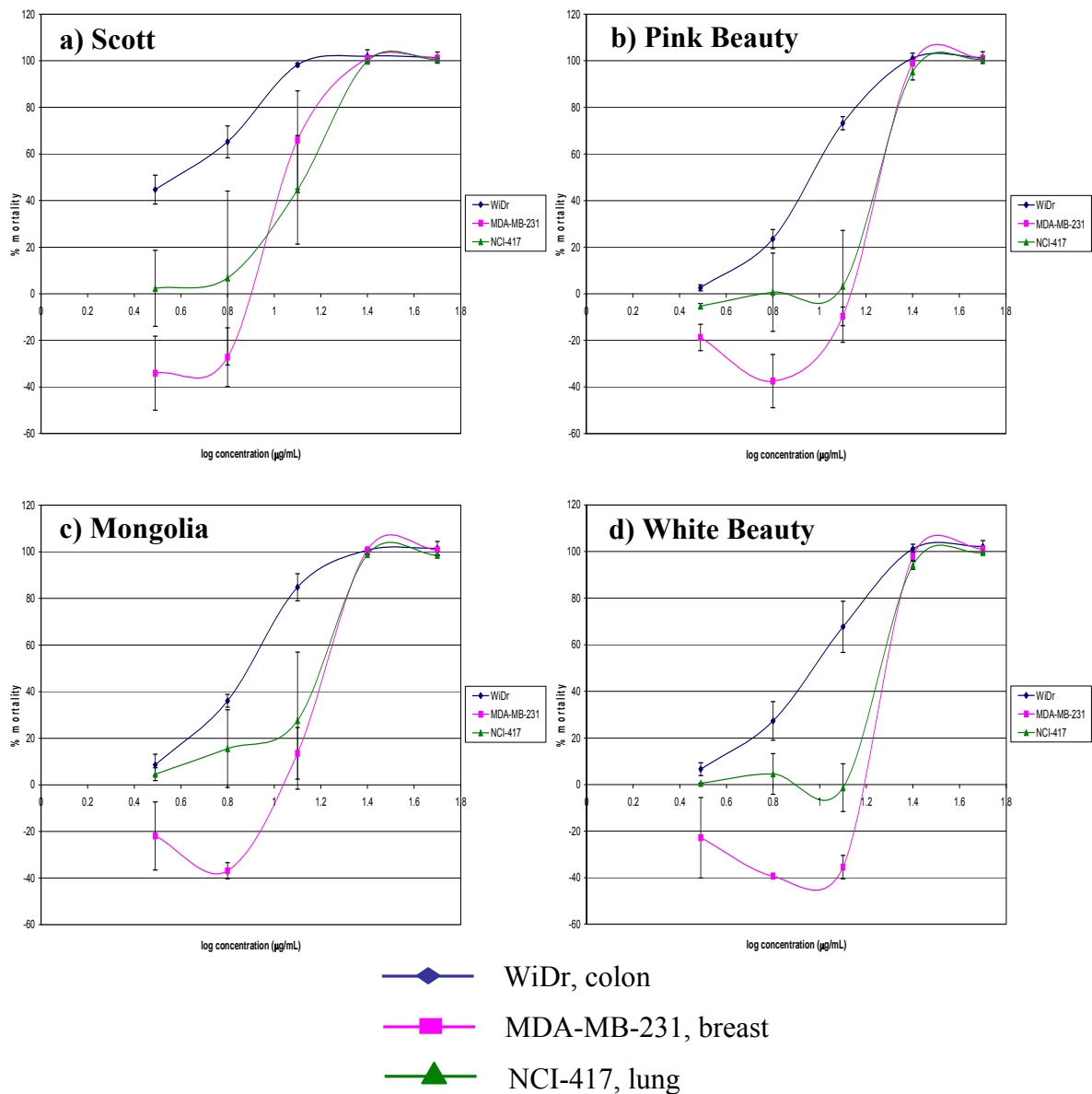

Note: The 50% inhibitory concentration is the midpoint of the sigmoid curve. ($n = 6$).

Figure 4.1. Inhibition induced by saponins present in the 70% MeOH seed extract of four varieties of *Saponaria vaccaria* L. (a) Scott, (b) Pink Beauty, (c) Mongolia and (d) White Beauty at five different concentrations (50, 25, 12.5, 6.25 and 3.13 µg/mL) on three human cancer cell lines.

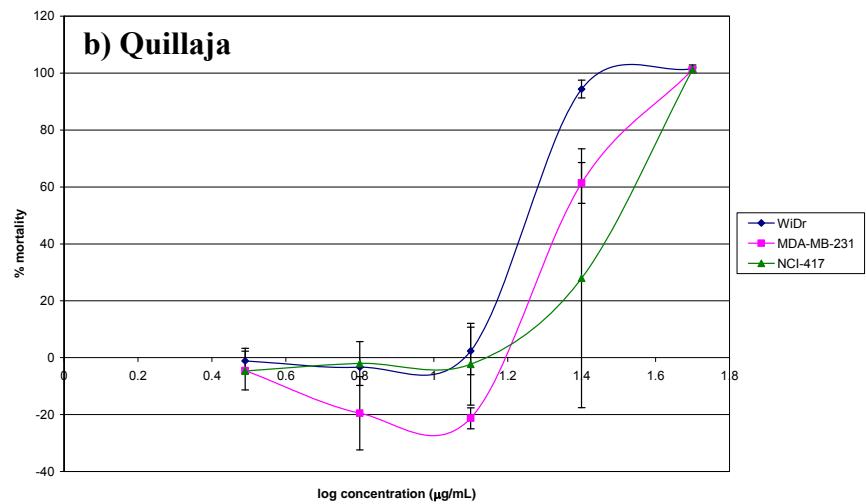
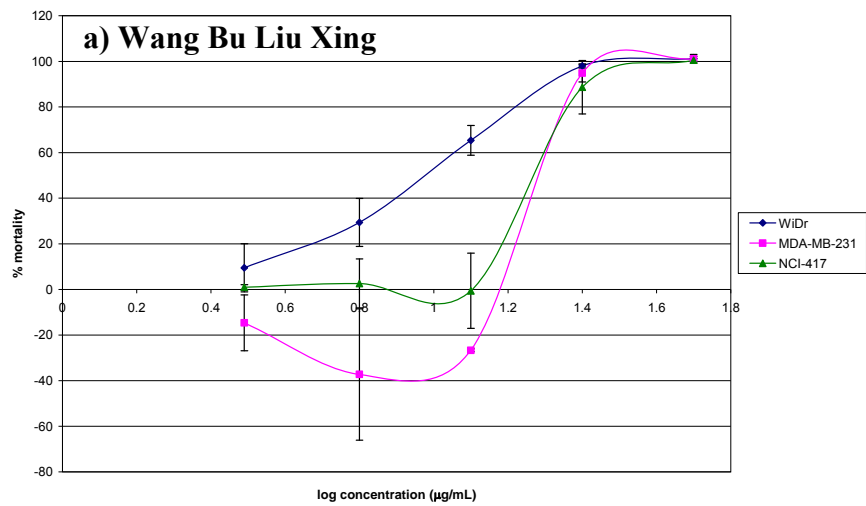

- ◆— WiDr, colon
- MDA-MB-231, breast
- ▲— NCI-417, lung

Note: The 50% inhibitory concentration is the midpoint of the sigmoid curve ($n = 6$).

Figure 4.2. Inhibition induced by saponins present in the 70% MeOH seed extract of **a)** *Saponaria vaccaria* L. (commercial extract Wang Bu Liu Xing) and **b)** *Quillaja saponaria* M. at five different concentrations ($n = 6$) on three human cancer cell lines.

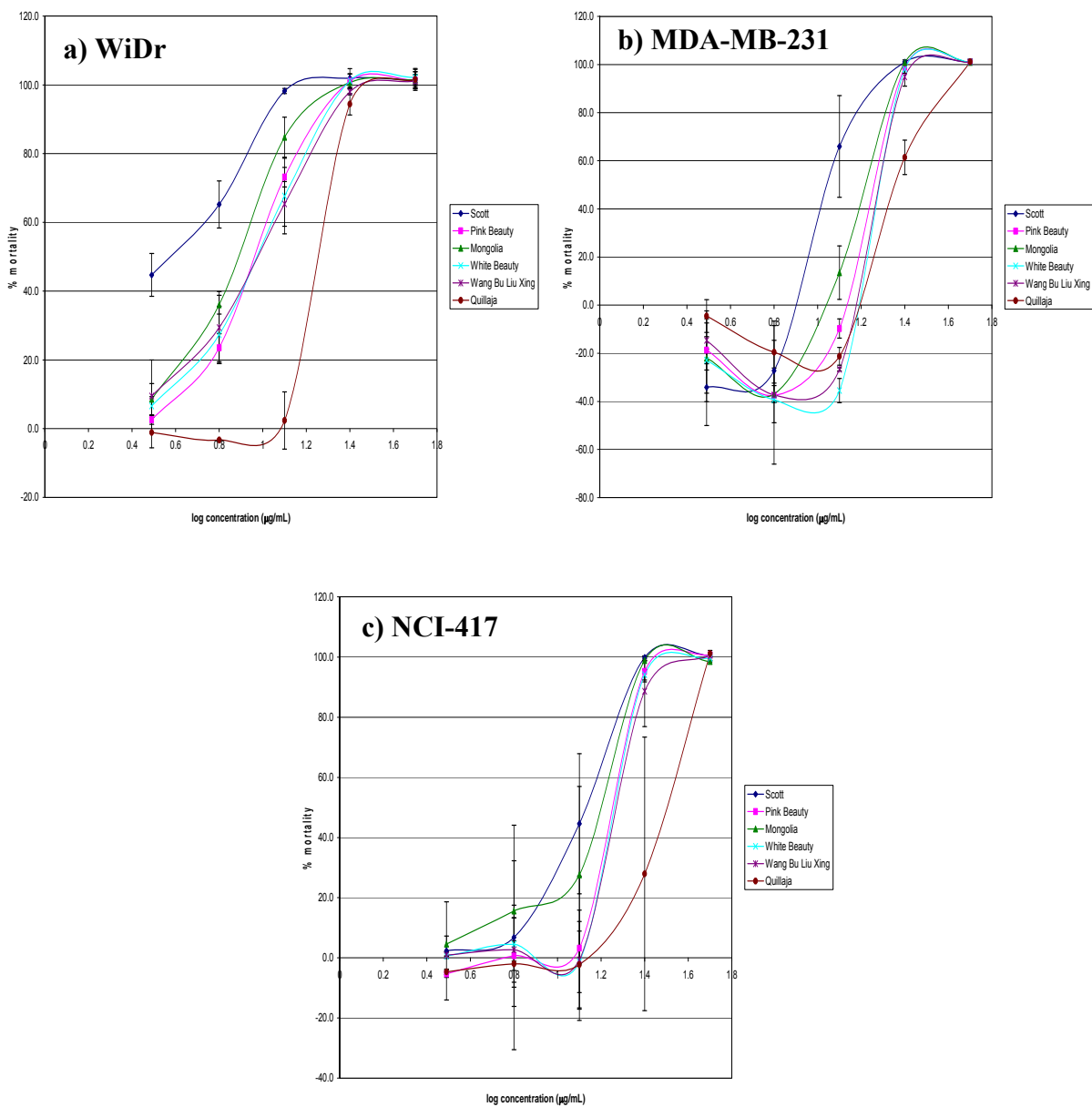

Note: The 50% inhibitory concentration is the midpoint of the sigmoid curve. ($n = 6$).

Figure 4.3. Mortality induced by saponins present in the 70% MeOH seed extract of four *Saponaria vaccaria* L. varieties (Scott, Pink Beauty, Mongolia and White Beauty); a commercial extracts from *S. vaccaria* seed (Wang Bu Liu Xing) and *Quillaja saponaria* M. on **a)** human colon cancer cell line WiDr, **b)** human breast cancer cell line MDA-MB-231, and **c)** human lung cancer cell line NCI-417.

Table 4.1. IC₅₀ values of extracts from four varieties of *Saponaria vaccaria* L. seed and from commercial extract Wang Bu Liu Xing, quillaja and quinoa saponins against the colon cancer cell line WiDr.

Cow cockle variety	70% MeOH extract
	IC ₅₀ (µg/mL) [†]
Scott WT	3.80 ± 0.600*
Pink Beauty	9.10 ± 0.300*
Mongolia	7.65 ± 0.250*
White Beauty	9.40 ± 1.100 [‡]
Wang Bu Liu Xing (Botanicum brand)	9.45 ± 0.950 ^{*‡}
Quillaja saponin	17.9 ± 0.707
Quinoa saponin	> 50

[†] *Saponaria vaccaria* L. IC₅₀ values were based on estimated saponin content of the crude extract and expressed as mean ± S.D. ($n = 6$). Significant values are denoted by * for $P < 0.05$ in comparison to Quillaja extract. Significant values within Scott WT variety and the extracts from MG and WBLX are denoted by [‡] for $P < 0.05$ (t -test).

Table 4.2. IC₅₀ values of extracts from four varieties of *Saponaria vaccaria* L. seed and from commercial extract Wang Bu Liu Xing, quillaja and quinoa saponins against the breast cancer cell line MDA-MB-231.

Cow cockle variety	70% MeOH extract
	IC ₅₀ (µg/mL) [†]
Scott WT	11.35 ± 1.250*
Pink Beauty	18.40 ± 0.200
Mongolia	16.80 ± 0.600*
White Beauty	19.55 ± 0.050
Wang Bu Liu Xing (Botanicum brand)	19.40 ± 0.100
Quillaja saponin	22.90 ± 1.131
Quinoa saponin	> 50

[†] *Saponaria vaccaria* IC₅₀ values were based on estimated saponin content of the crude extract and expressed as mean ± S.D. ($n = 6$). Significant values are denoted by * for $P < 0.05$ (t -test) in comparison to Quillaja extract. No significant differences were found within the other extracts tested for cytotoxic activity on MDA-MB-231.

Table 4.3. IC₅₀ values of extracts from four varieties of *Saponaria vaccaria* L. seed and from commercial extract Wang Bu Liu Xing, quillaja and quinoa saponins against the lung cancer cell line NCI-417.

Cow cockle variety	70% MeOH extract
	IC ₅₀ (µg/mL) [†]
Scott WT	12.55 ± 4.313
Pink Beauty	17.75 ± 1.909
Mongolia	15.15 ± 3.182
White Beauty	18.25 ± 0.636
Wang Bu Liu Xing (Botanicum brand)	18.65 ± 2.051
Quillaja saponin	28.9 ± 9.899
Quinoa saponin	> 50

[†] *Saponaria vaccaria* L. IC₅₀ values were based on estimated saponin content of the crude extract and expressed as mean ± S.D. (*n* = 6). With the exception of Quinoa, no significant differences were found among the extracts tested for cytotoxic activity on NCI-417.

4.2. Saponin profile of the seed extracts of *S. vaccaria* L.

The methanol extracts from all four *S. vaccaria* varieties were analysed by HPLC-PDA-MS. Profiles of the seed extracts were found to contain the same saponins, albeit in different proportions. Figure 4.4 shows the PDA ($\lambda = 209\text{nm}$) of the section of the chromatogram (10-25 min) corresponding to saponins present in the methanol extract of Pink Beauty. Bidesmosidic triterpene saponins Segetoside I (MW 1464) and Vaccaroside E (MW 1422) were readily identified by their molecular weights in the MS spectra obtained by single ion scanning (data not shown). It was observed that many saponins co-elute under one signal (peak), masking the actual number of saponins present in the extract.

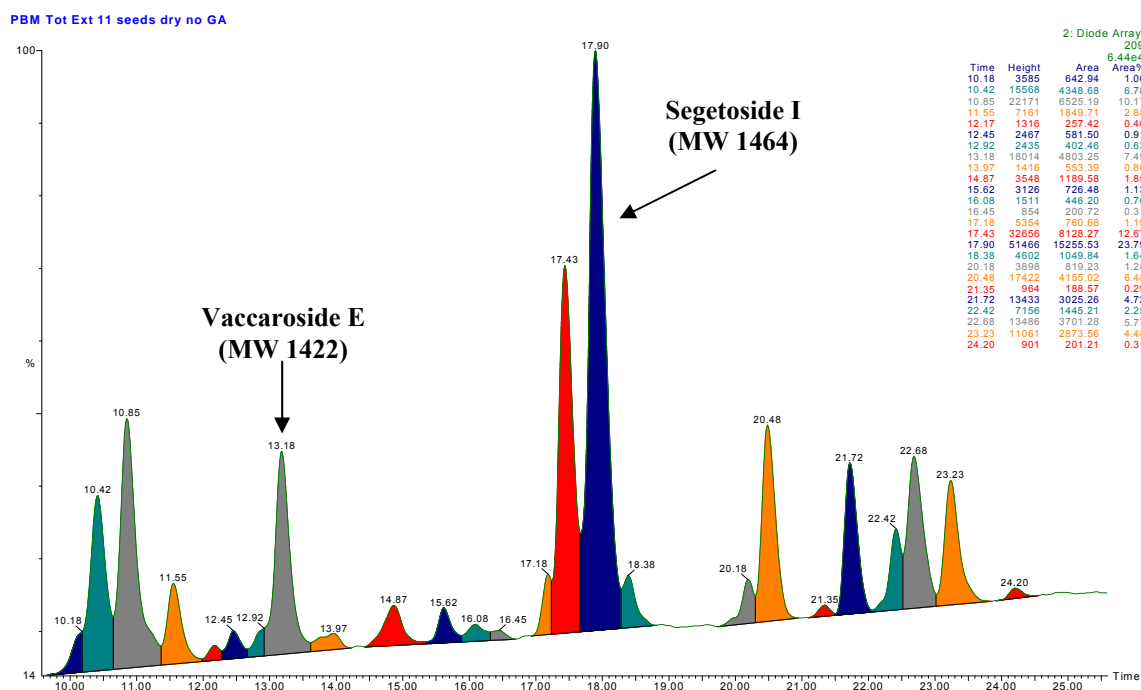

Figure 4.4. HPLC chromatogram of total MeOH extract from *Saponaria vaccaria* L var. Pink Beauty.

4.3. Reverse phase column chromatography (RPCC), High Performance Liquid Chromatography-Photo Diode Array Detection-Mass Spectrometry (HPLC-PDA-MS) and biological evaluation of fractions

The methanol extract from 100 g de-fatted seed of *S. vaccaria* L. var. Pink Beauty was applied into glass column and 30-100 mL fractions were collected and analysed by HPLC-PDA-MS. It was observed that many of the fractions were a mixture of several saponins and that many signal peaks overlap, making the analytical process more complicated. Figure 4.5 shows a comparison of the LC-PDA profiles of the crude methanol extract (top) and two fractions (bottom) eluted from the column during the separation of compounds according to their different polarities.

Major components of these fractions were identified (Table 4.4.) as a result of continuous fractionations and a better understanding on the metabolic profiling of *S. vaccaria*.

Several known cyclopeptides such as segetalin A (**8**), segetalin B (**9**), and segetalin D, as well as some bisdesmosidic triterpene saponins (e.g. vaccaroside E, MW=1422; vaccaroside G, MW=1406; segetoside H, MW=1448; segetoside I, MW=1464) were readily identified by selected ion extraction of quasi-molecular ions from the total ion chromatogram (TIC) and confirmed by their mass spectra (MS). Many of the saponins had not been previously reported and remained to be elucidated. Using photodiode array (PDA) and single quadrupole electrospray mass detection (SQMS), a method for analysis and profiling of bisdesmosidic saponins in *S. vaccaria* was developed (Balsevich *et al.*, 2006, see Appendix 1).

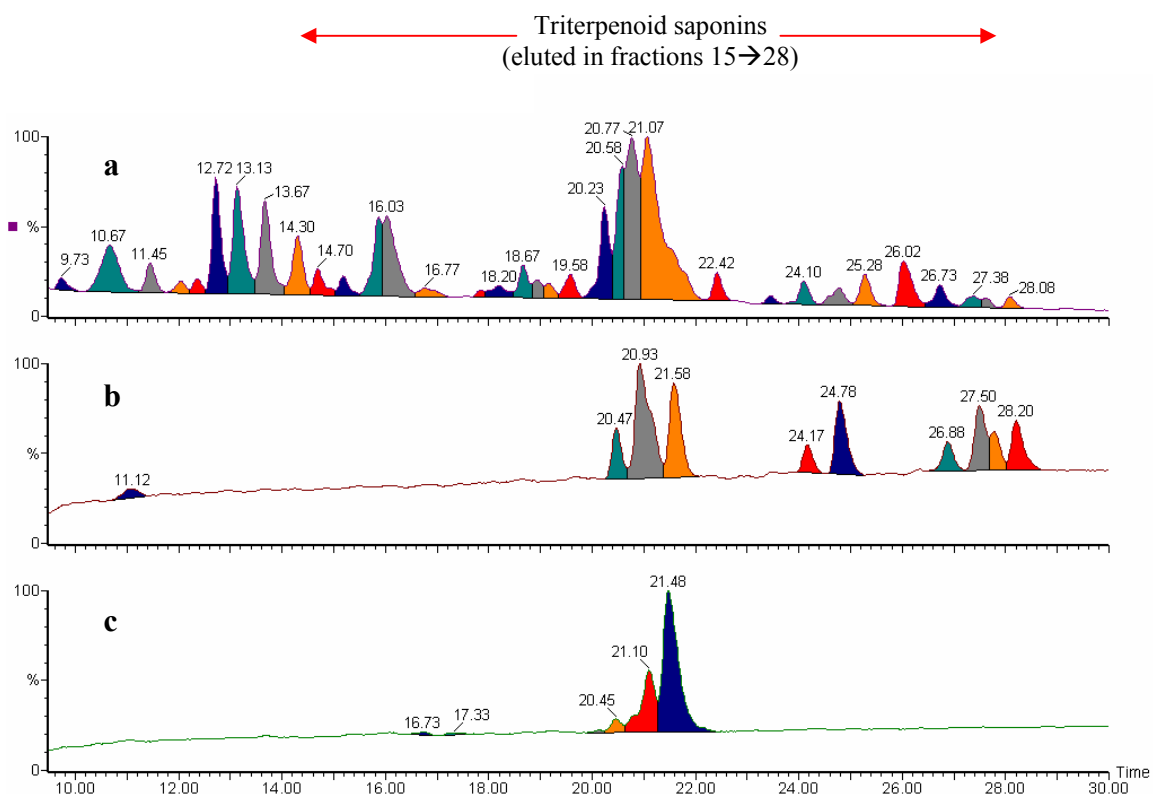

Figure 4.5. Liquid chromatography-Photo Diode Array profiles of the crude methanol extract (a) and two fractions (b, c) eluted from the column during the separation of compounds according to their different polarities.

In summary, five known saponins, as well as twenty new quillaic acid and gypsogenin-type bisdesmosides were detected via mass spectral analysis. Five of these (MWs= 1538, 1554, 1580, 1596 and 1638) were tentatively identified as pentose homologues of known saponins, having an added xylose residue linked to the 3-*O*-glucuronyl group (1 → 3) (Table 4.5). The quillaic acid-type bisdesmosidic saponins were classified in three Types according to the sugar chains as shown in Fig. 4.6.

The structures of triterpene saponins Vaccaroside E (PC 1422), Segetoside I (PC 1464), Segetoside I + Acetate (PC 1506), New Saponin (PC 1596), Segetoside H (PC 1448) and Vaccaroside JB (New Saponin PC 1526) are shown in Appendix 2.

Table 4.4. Fractionation of cow cockle extract (Pink Beauty) on Supelco Discovery DSC-18Lt reverse phase packing (performed by J. Balsevich).

Fraction No.	% MeOH	Yield and observations	Main peaks (MS)
1	0	4 g (sugars)	---
2	10	0.7 g (sugars)	---
3	10	---	---
4/5	15	---	---
6/7	25	---	---
8/9	25	ca. 100 mg	MW 520 sucrose ester (dihydrocinnamate)
10/11	30-35	226 mg, yellow	MW 726 vaccarin
12/13	40	yellow	MW 726, MW 564
14	45	87 mg, yellow	MW 564, 904
15/16	45-50	215 mg	MW 484 segetalin B
17/18	50-55	17-20 comb.	MW 609 segetalin A + others
19/20	55-60	540 mg	
21/22	60-65	328 mg	MW 719 segetalin D + mono- and bisdesmosidic saponins
23/24	70	380 mg	Mainly monodesmosides + MW1464 segetoside I
25/26	80	1.2 g	MW 1278 vaccaroside B + bisdesmosidic saponins
27/28	80	280 mg	Cryst. MW 1640, MW 1772; mother liq. Mainly MW 1448
29/30	100	100 mg	Not examined

Table 4.5. Bisdesmosidic saponins observed in *Saponaria vaccaria* L. var. Scott WT. Retention times were obtained by selected ion extraction from TIC of appropriate quasi-molecular ion. Disaccharide = 3-*O*- β -D-Galp-(1 \rightarrow 2)- β -D-GlcpA; trisaccharide = 3-*O*- β -D-Xylp-(1 \rightarrow 3)-[β -D-Galp-(1 \rightarrow 2)]- β -D-GlcpA.

[M-H] ⁻ m/z	Aglycone	3- <i>O</i> -substituents	Compound	Fragment ions m/z	Rt (min) (single run)
1394	Quillaic acid	Disaccharide	Unknown	823, 485	10.48
1406	Gypsogenin	Disaccharide	Vaccaroside G	807, 469	17.81
1422	Quillaic acid	Disaccharide	Vaccaroside E	823, 485	13.55
1436	Quillaic acid	Disaccharide	Unknown	823, 485	18.36
1448	Gypsogenin	Disaccharide	Segetoside H	807, 469	22.07
1464	Quillaic acid	Disaccharide	Segetoside I	823, 485	18.36
1478	Quillaic acid	Disaccharide	Unknown	823, 485	23.59
1506	Quillaic acid	Disaccharide	Segetoside I Ac	823, 485	20.87
1526	Quillaic acid	Trisaccharide	Unknown	955, 485	11.27
1538	Gypsogenin	Trisaccharide	New saponin	939, 469	17.58
1554	Quillaic acid	Trisaccharide	New saponin	955, 485	13.52
1556	Quillaic acid	Disaccharide	Unknown	823, 485	10.60
1568	Quillaic acid	Trisaccharide	Unknown	955, 485	18.23
1580	Gypsogenin	Trisaccharide	New saponin	939, 469	21.69
1596	Quillaic acid	Trisaccharide	New saponin	955, 485	18.13
1598	Quillaic acid	Disaccharide	Unknown	823, 485	17.91
1610	Quillaic acid	Trisaccharide	Unknown	955, 485	23.27
1626	Quillaic acid	Trisaccharide	New saponin	985, 485	17.51
1638	Quillaic acid	Trisaccharide	New saponin	955, 485	20.52
1640	Quillaic acid	Disaccharide	Unknown	823, 485	23.06
1688	Quillaic acid	Trisaccharide	Unknown	955, 485	10.69
1730	Quillaic acid	Trisaccharide	Unknown	955, 485	11.91
1730	Quillaic acid	Trisaccharide	Unknown	955, 485	17.76
1772	Quillaic acid	Trisaccharide	Unknown	955, 485	22.75
1814	Quillaic acid	Trisaccharide	Unknown	955, 485	23.53

Note: Table reproduced from Balsevich *et al.*, 2006.

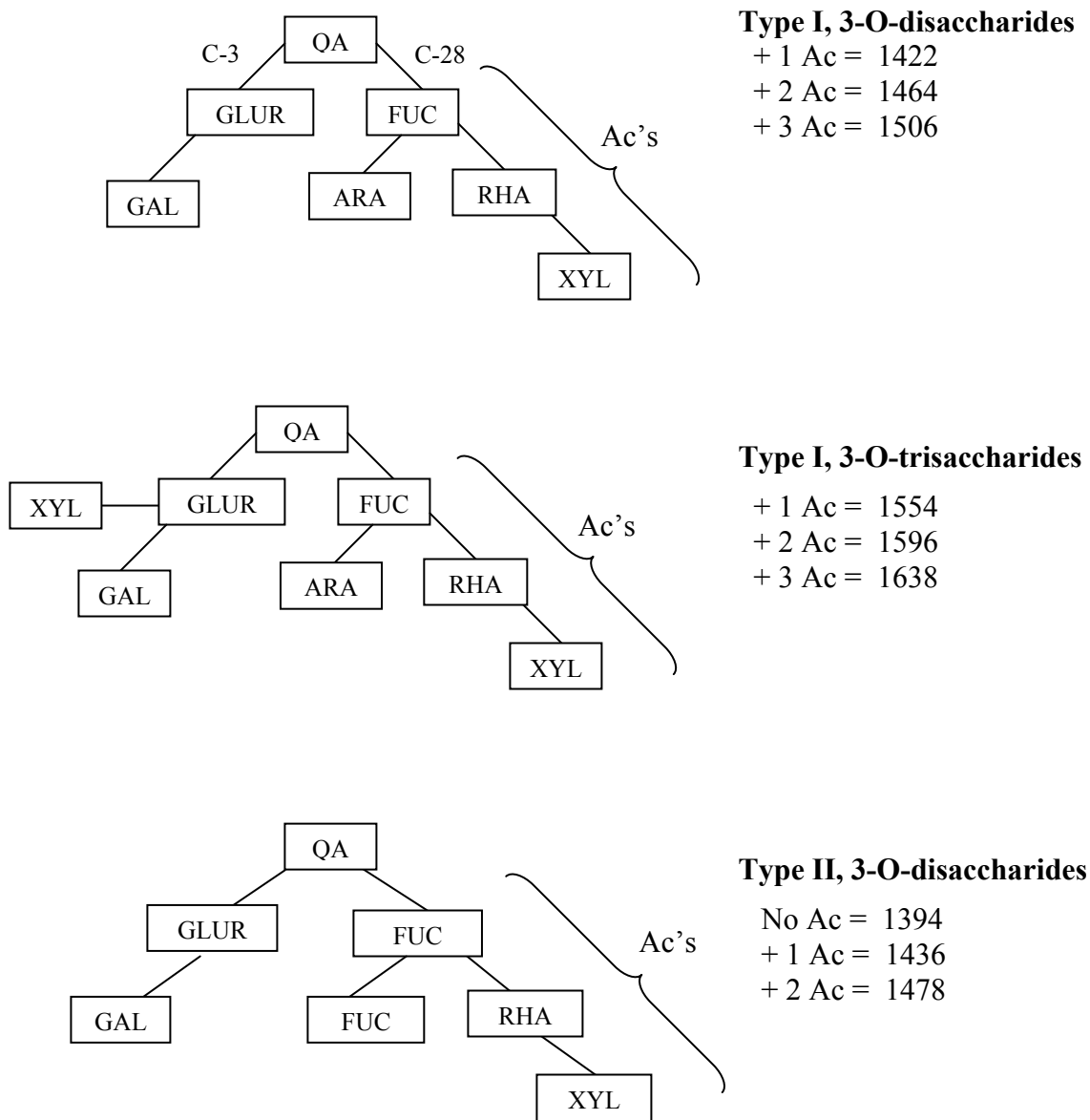

Legend: QA = quillaic acid, GLUR = glucopyranosiduronic acid, GAL = galactopyranose, XYL = xylopyranose, FUC = fucopyranose, ARA = arabinofuranose, RHA = rhamnopyranose, GLC = glucopyranose, Ac = acetate.

Figure 4.6. Gross structures of quillaic acid-type bisdesmosidic triterpene saponins identified in *Saponaria vaccaria* L.

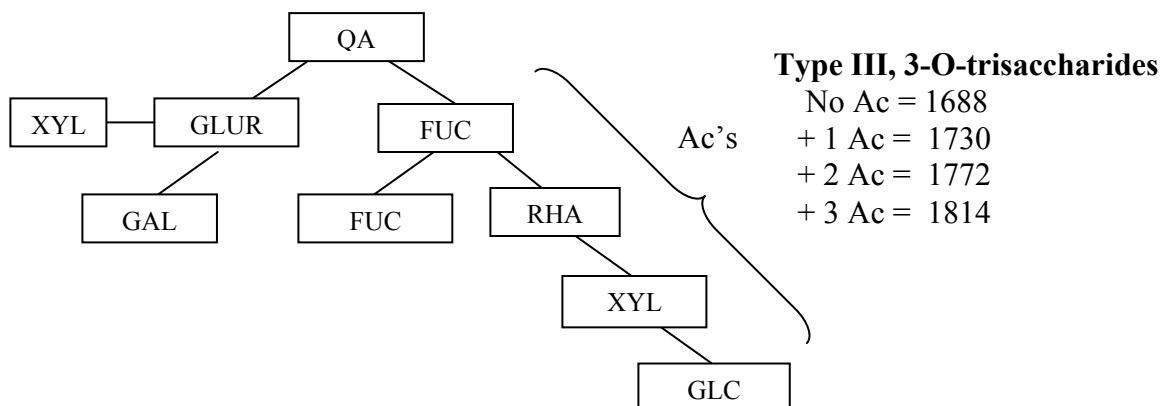
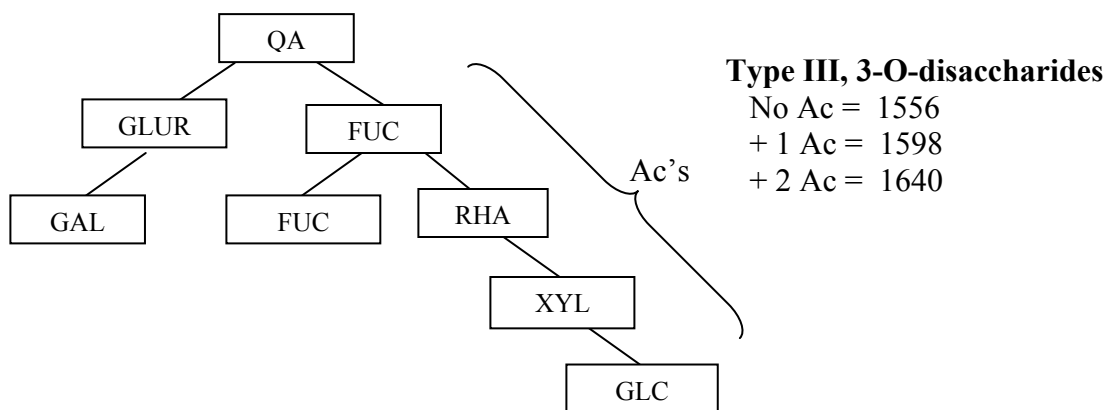
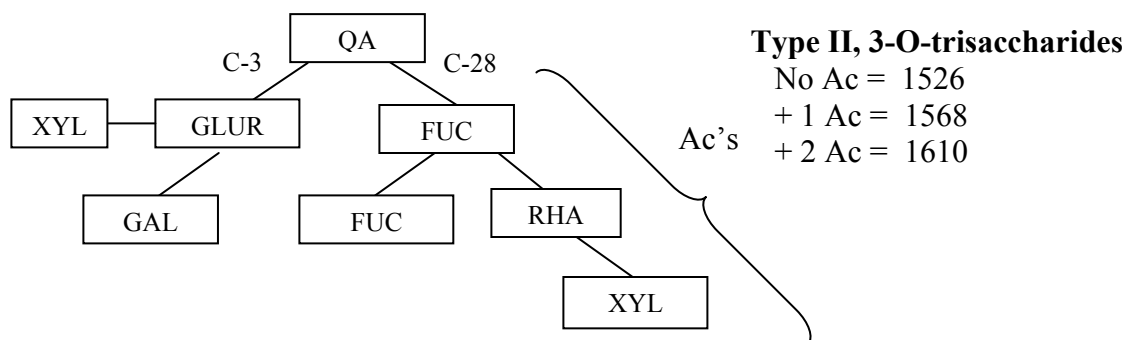

Legend: QA = quillaic acid, GLUR = glucopyranosiduronic acid, GAL = galactopyranose, XYL = xylopyranose, FUC = fucopyranose, ARA = arabinofuranose, RHA = rhamnopyranose, GLC = glucopyranose, Ac = acetate.

Figure 4.6. (continued) Gross structures of quillaic acid-type bisdesmosidic triterpene saponins identified in *Saponaria vaccaria* L.

All fractions collected from the RPCC separation were evaluated for their cytotoxic activity against three human cancer cell lines (colon, breast, and lung). Only saponin-containing fractions (from Fraction 15-16) showed moderate activities against the cancer cell lines tested. These fractions were tested at least three more times ($n \geq 9$) and were also evaluated on the human fibroblast normal cell line CRL-2522 which was used as a control.

The effects of extracts were expressed by IC_{50} values calculated from dose response curves. Dose-response curves were established of selected fractions showing cytotoxic activity (Fractions 14 – 27-28). From these curves it is only evident the reduced activities of Fraction 14 and ML 27-28 on WiDr and MDA-MB-231 cell lines, as well as the moderate activity exerted by all fractions analysed on the human fibroblast normal cell line CRL-2522 (Fig. 4.7).

IC_{50} values are presented in Table 4.6 and results from each cell line tested are shown graphically in Figs. 4.8, 4.9, 4.10 and 4.11.

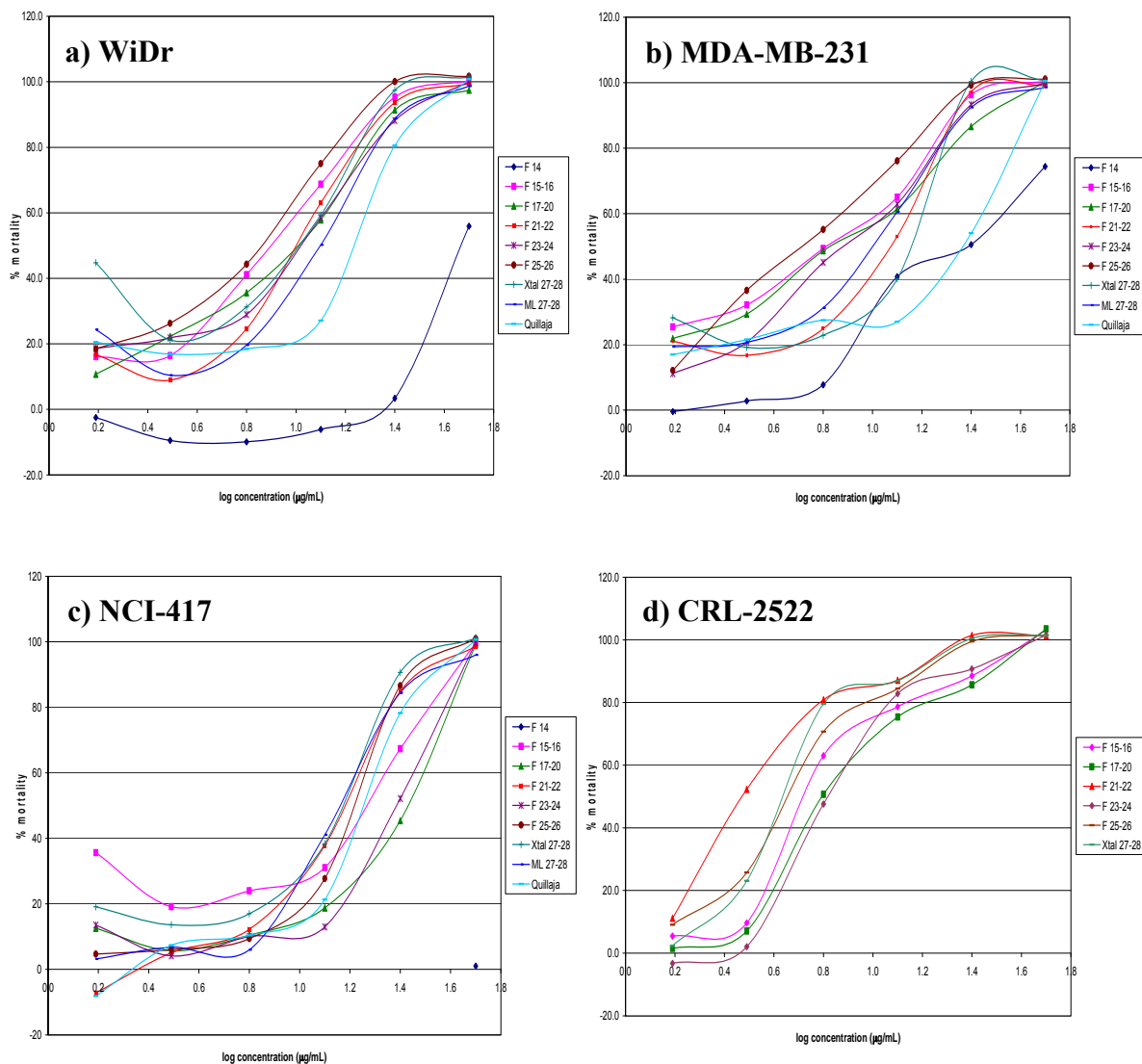

Note: The 50% inhibitory concentration is the midpoint of the sigmoid curve. ($n \geq 6$).

Figure 4.7. Mortality induced by fractions collected from the reverse phase chromatographic separation (RPCC) of a 70% MeOH seed extract from *Saponaria vaccaria* L. var. Pink Beauty on (a) human colon cancer cell line WiDr; (b) human breast cancer cell line MDA-MB-231; (c) human lung cancer cell line NCI-417; and (d) human fibroblast normal cell line CRL-2522. Standard deviations have been omitted for clarity.

Table 4.6. IC₅₀ values of extracts and fractions from *Saponaria vaccaria* L. seed (pink beauty variety) tested *in vitro* using the MTT bioassay against three human cancer cell lines WiDr (colon), MDA-MB-231 (breast), NCI-417 (lung) and human fibroblast normal cell line CRL-2522.

Cell line Sample fraction	WiDr (colon)	MDA-MB-231 (breast)	NCI-417 (lung)	CRL-2522 (fibroblast)
	IC ₅₀ (µg/mL)*	IC ₅₀ (µg/mL)*	IC ₅₀ (µg/mL)*	IC ₅₀ (µg/mL)*
Fraction 3 [†]	> 50 µg/mL	> 50 µg/mL	> 50 µg/mL	N/D
Fraction 4	> 50 µg/mL	> 50 µg/mL	> 50 µg/mL	N/D
Fraction 6-7	> 50 µg/mL	> 50 µg/mL	> 50 µg/mL	N/D
Fraction 14 [‡]	46.15 ± 0.950	26.15 ± 16.350	> 50 µg/mL	N/D
Fraction 15-16 [‡]	8.70 ± 1.436	4.55 ± 2.257	17.87 ± 1.101	5.30 ± 0.200
Fraction 17-20 [§]	11.25 ± 2.727	10.10 ± 4.168	22.63 ± 4.599	6.25 ± 0.050
Fraction 21-22 ^{**}	10.00 ± 1.994	10.72 ± 2.775	16.44 ± 2.796	3.60 ± 0.265
Fraction 23-24 ^{††}	11.80 ± 3.336	9.50 ± 3.082	19.45 ± 3.793	7.70 ± 0.451
Fraction 25-26 ^{††}	8.43 ± 2.229	6.65 ± 2.108	13.35 ± 2.233	5.03 ± 0.267
Crystal fraction 27-28 ^{‡‡}	8.75 ± 2.249	12.28 ± 2.224	13.94 ± 1.898	4.67 ± 0.133
ML 27-28 ^{§§}	12.80 ± 3.117	10.18 ± 2.996	17.30 ± 4.705	N/D
Quillaja saponin	24.37 ± 7.347	28.25 ± 9.250	27.27 ± 6.886	N/D

Note: The range of concentrations tested was 3.1 – 50 µg/mL. N/D = not determined

* Numbers represent the mean IC₅₀ values ± S.E.M., n ≥ 6.

[†] Fraction 3 = eluted from the column with 20% MeOH;

[‡] Fractions 14-16 = mixture of polar and non-polar CP's;

[§] Fractions 17-20 = mostly CP's and some saponins;

^{**} Fractions 21-22 = mostly monodesmosidic saponins and segetalin D;

^{††} Fraction 23-26 = bisdesmosidic saponins;

^{‡‡} Crystal fraction 27-28 = precipitate formed upon cooling of fraction 25-26;

^{§§} ML 27-28 = Soluble portion of fraction 27-28;

Quillaja Saponin = 70% MeOH extract from commercially available extract (Sigma)

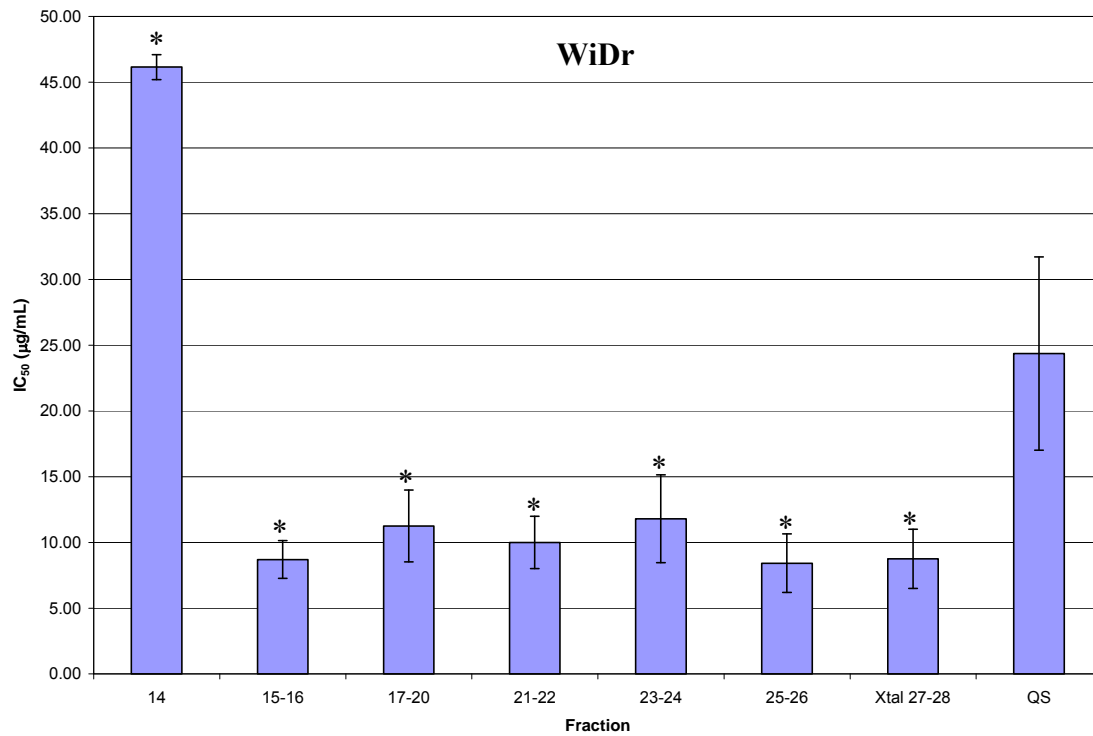

Note: IC₅₀ values are expressed as mean ± S.E.M ($n \geq 6$). Significant values within Fraction 14 and other RPCC fractions are denoted by * for $P < 0.05$ (t -test). No other significant differences were observed.

Figure 4.8. Comparison of IC₅₀ values of extracts and fractions from seed of *Saponaria vaccaria* L. (pink beauty variety) and commercially available saponin mixture from *Quillaja saponaria* (Sigma brand, control) tested *in vitro* using the MTT bioassay against the human colon cancer cell line WiDr.

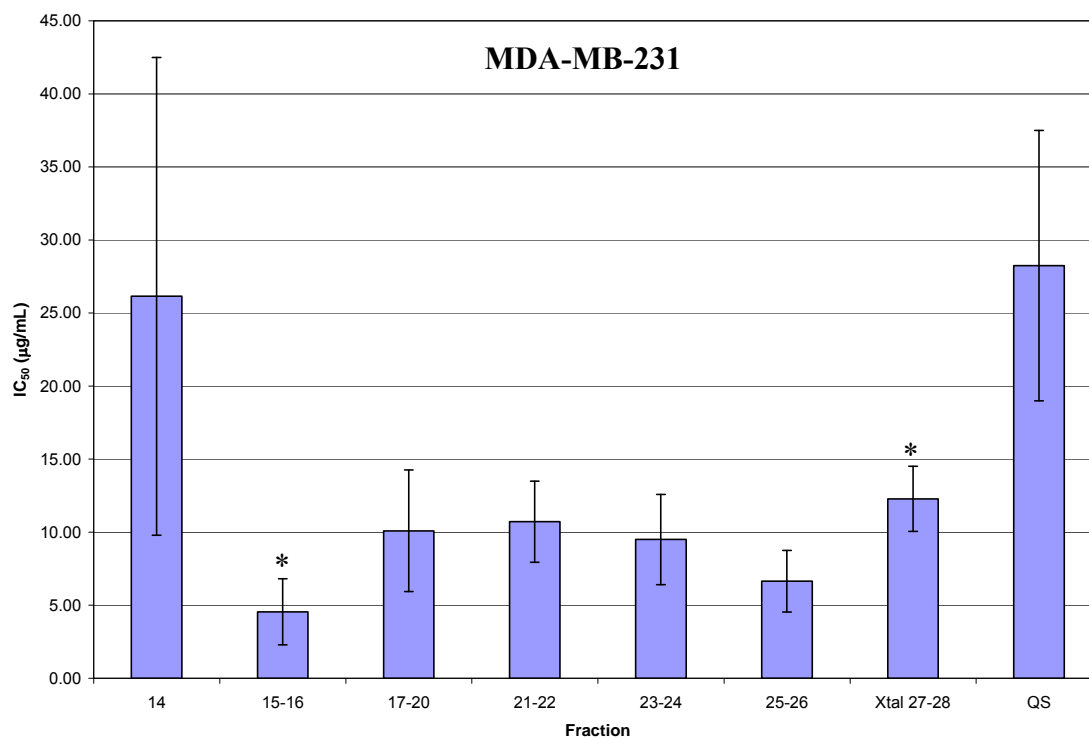

Note: IC₅₀ values are expressed as mean ± S.E.M ($n \geq 6$). Significant value within Fraction 15-16 and Xtal 27-28 is denoted by * for $P < 0.05$ (t -test). No other significant differences were observed.

Figure 4.9. Comparison of IC₅₀ values of extracts and fractions from seed of *Saponaria vaccaria* L. (pink beauty variety) and commercially available saponin mixture from *Quillaja saponaria* (Sigma brand, control) tested *in vitro* using the MTT bioassay against the breast cancer cell line MDA-MB-231.

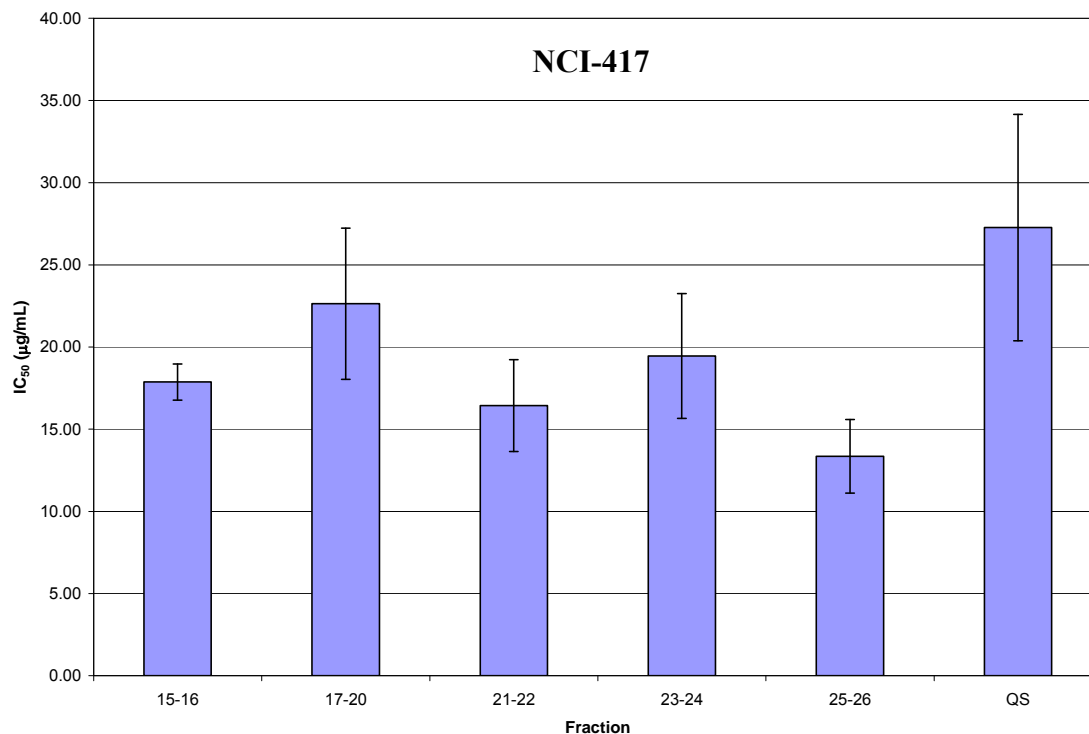

Note: IC₅₀ values are expressed as mean \pm S.E.M ($n \geq 6$). No significant differences were found within any fraction tested for cytotoxic activity on NCI-417.

Figure 4.10. Comparison of IC₅₀ values of extracts and fractions from seed of *Saponaria vaccaria* L. (pink beauty variety) and commercially available saponin mixture from *Quillaja saponaria* (Sigma brand, control) tested *in vitro* using the MTT bioassay against the human lung cancer cell line NCI-417.

CRL-2522

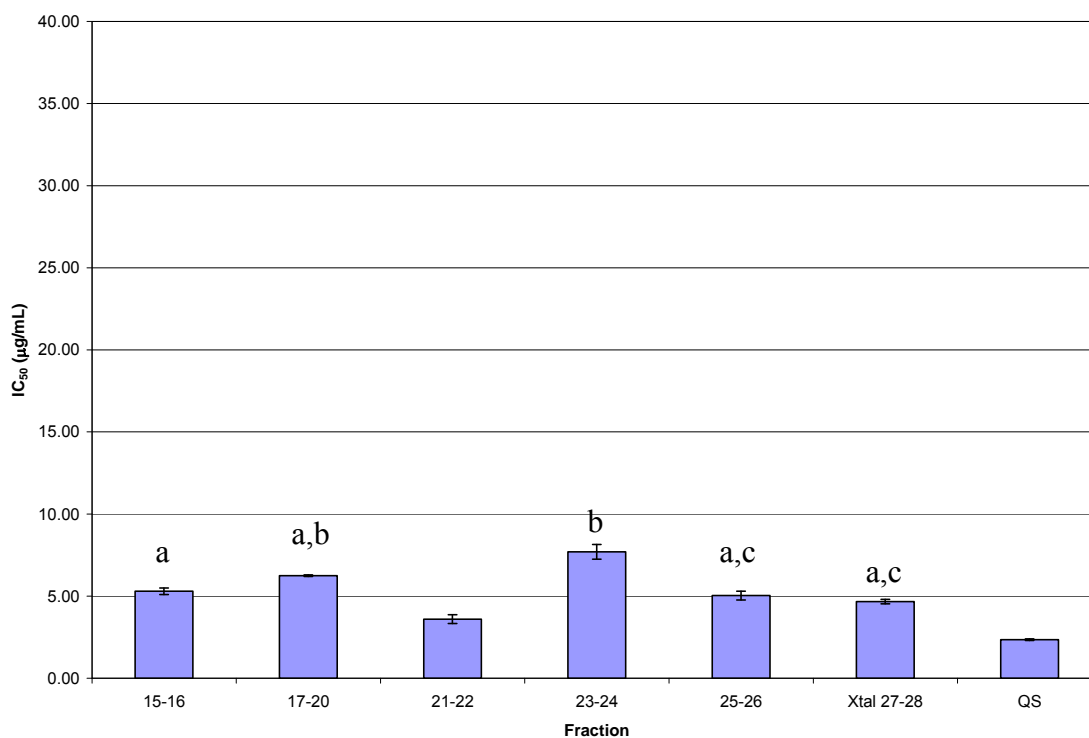

Note: IC₅₀ values are expressed as mean \pm S.E.M ($n \geq 6$). Same letters denote mean values which are not statistically different (t -test $P = 0.05$)

Figure 4.11. Comparison of IC₅₀ values of six fractions from seed of *Saponaria vaccaria* L. (pink beauty variety) tested *in vitro* using the MTT bioassay against the human fibroblast normal cell line CRL-2522.

All bisdesmosidic saponin-containing fractions (fractions 15-28) showed cytotoxic activity. Sugar, phenolic, and cyclic peptide-containing fractions (fractions 1-14) did not show any cytotoxic activity in the MTT assay at the highest concentration tested (50 $\mu\text{g/mL}$). Fractions 14-20 were mostly cyclic peptide-containing fractions with traces of saponins, thus the activity observed.

Although it is believed that there are significant differences in the cytotoxic responses of Fractions 15-16 and 25-26 relative to Quillaja saponin to the breast cancer cell line MDA-MB-231, these differences were not observed when the Student's t-test analysis assuming unequal variances was employed.

The amount of cell response variation observed in the MTT assay has been attributed to cell variability from assay to assay. These variations can be observed in the following range of IC₅₀ values of the three samples discussed above (Table 4.7).

Table 4.7. IC₅₀ values (µg/mL) obtained from dose-response curves of the RPCC Fractions 15-16, 25-26 and the 70% methanol extract from commercial quillaja extract on human breast cancer cell line MDA-MB-231.

Fxn 15-16	Fxn 25-26	QS
IC₅₀ (µg/mL)		
0.2	3.0	19.0
0.3	3.0	37.5
0.5	10.2	
0.6	10.4	
2.0		
3.3		
14.4		
15.1		

Note: IC₅₀ values represent the average of one independent experiment performed in triplicate.

Saponin-containing fractions were further purified by successive column chromatographic separations. Fractions containing semi-pure saponins (80% +) were obtained and their molecular weights (MW) determined by HPLC-PDA-MS. The major compound with MW 1278 corresponded to the monodesmosidic saponin Vaccaroside B, and compounds with MW 1448 and 1464 corresponded to the bisdesmosidic saponins Segetoside H and Segetoside I, respectively. All three saponins were evaluated for

cytotoxic activity using the MTT assay on human cancer cell lines WiDr (colon), MDA-MB-231 (breast) and NCI-417 (lung) as well as the human fibroblast normal cell line CRL-2522. Commercially available Kochia (fireweed) saponin (*Kochia scoparia* (L.) Roth, Chenopodiaceae) and horse chestnut (*Aesculus hippocastanum* L., Hippocastanaceae) triterpenic saponin mixture, β -escin, both containing structurally similar sapogenin as in *S. vaccaria* (oleanane type), were used as controls. It was interesting to notice that only the bisdesmosidic saponins showed high cytotoxicity, and that this activity was particularly enhanced against the breast cancer cell line MDA-MB-231. Dose-response curves for the triterpene bisdesmosidic saponins Segetoside H (MW 1448) and Segetoside I (MW 1464) were generated for calculation of IC_{50} values (Fig. 4.12).

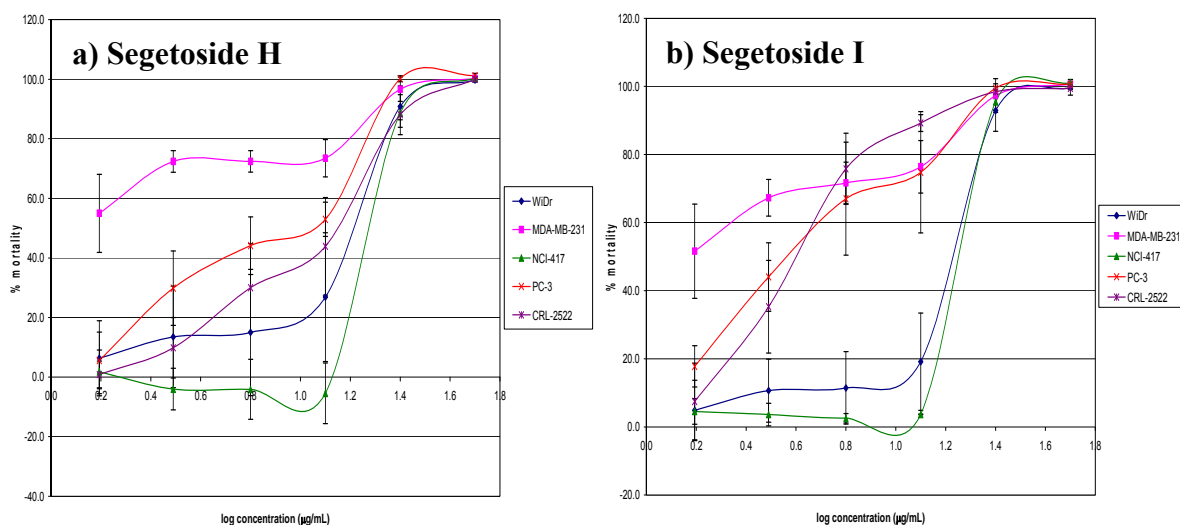

Figure 4.12. Inhibition induced by bisdesmosidic triterpene saponin **a)** Segetoside H (MW 1448) and **b)** Segetoside I (MW 1464) isolated from the seed of *Saponaria vaccaria* L. at six different concentrations on five human cell lines. ($n \geq 6$).

The extract of the fruit of *Kochia* has been used as a traditional Oriental medicine for the treatment of several ailments (jaundice, edema, etc.), it is not reported to have any cytotoxic, antitumor or anticancer properties. It is also worth mentioning the negative results obtained from *kochia* saponin since the major constituents in the fruits are momordin Ic, an oleanolic acid oligoglycoside (monodesmosidic saponin), and oleanoic acid (Wen *et al.*, 1995). β -Escin, another oleanane-type monodesmosidic saponin and the principal biologically active component of horse chestnut, showed moderately positive results. β -Escin has been mainly used for the treatment of venous insufficiency, diabetes, and as anti-inflammatory (Sirtori 2001; Matsuda *et al.*, 1997), but no reports on antitumor or anticancer activity were found, however, escins are known to be highly hemolytic (Voutquenne *et al.*, 2002; Ivanov *et al.*, 1988) which may account in part for the observed cytotoxicity. IC₅₀ values are reported in Table 4.8.

Table 4.8. IC₅₀ values ($\mu\text{g/mL}$) from the dose-response curves of monodesmosidic triterpene saponin Vaccaroside B, bisdesmosidic triterpene saponins Segetoside H and Segetoside I isolated from *Saponaria vaccaria* L. seed, *Kochia* saponin and horse chestnut β -escin saponin tested *in vitro* against the cancer cell lines WiDr, MDA-MB-231, and NCI-417, and the normal fibroblast line CRL-2522 using the MTT bioassay.

Sample	WiDr	MDA-MB-231	NCI-417	PC-3	CRL-2522
	IC ₅₀ ($\mu\text{g/mL}$)				
Vaccaroside B (MW 1278)	> 50 $\mu\text{g/mL}$	> 50 $\mu\text{g/mL}$	> 50 $\mu\text{g/mL}$	N/D	> 50 $\mu\text{g/mL}$
Segetoside H (MW 1448)	15.85 \pm 0.495	1.26 \pm 0.071	18.62 \pm 2.333	11.749 \pm 3.811	14.13 \pm 1.414
Segetoside I (MW 1464)	16.70 \pm 0.989	1.58 \pm 0.636	19.75 \pm 0.212	3.98 \pm 1.414	3.98 \pm 1.273
Kochia saponin	> 50 $\mu\text{g/mL}$	> 50 $\mu\text{g/mL}$	44	N/D	> 50 $\mu\text{g/mL}$
β-escin	21	9.5	18	N/D	27

N/D = Data not calculated

4.4. Purification of saponins by column chromatography (CC) using RP-Amberchrome[®] CG 300 chromatographic grade resin, their analysis by HPLC-PDA-MS and biological evaluation of fractions

In order to purify more of the bioactive bisdesmosidic saponins, 15 g of saponin mixture (SPM) was fractionated by column chromatography using Amberchrome resin CG-300S as the stationary phase. HPLC-PDA-MS analysis of the twenty-two fractions collected (CC-1 to CC-22) showed bisdesmosidic saponins starting from fraction 9. A detailed study on the saponin composition in each fraction was then performed (Table 4.9). As expected, it was noticed that the nature of the saponins and their amounts varied from fraction to fraction. Fraction 9 showed a mixture of cyclopeptide Segetalin B (MW484) with at least five other saponins, being monodesmosidic saponin Vaccaroside B (MW 1278) the one in greatest abundance relative to the other saponins in the fraction (~20% saponin content). Cyclopeptide Segetalin A (MW 609) was found present in Fraction 12 along with Vaccaroside B and other bisdesmosidic saponins. All remaining fractions were mixtures of bisdesmosidic saponins. The total ion chromatograms (TIC) of fraction CC-12 and CC-16, and both the PDA and TIC of fraction CC-19 are shown below (Figs. 4.13, 4.14, and 4.15). CC-19 is also a mixture of bisdesmosidic saponins having vaccaroside G (MW 1406) as the major compound (67%). CC-19 showed interesting cytotoxic properties and was obtained in high yield (ca. 300 mg). The cytotoxic results will be discussed below.

Table 4.9. Characterization of the major compounds from fractions eluted from the chromatographic separation of saponin mixture (SPM) by HPLC-PDA-MS analysis. Saponins with higher MW (i.e. 1638, 1640, 1772) are not shown.

Identified compounds with Retention times (Rt) below 20 min.

Fraction	Segetalin B (MW 484) Rt=5min	Segetalin A (MW609) Rt=8min	Vaccaroside B (MW 1278) Rt=13min	Saponin (MW 1526) Rt=14min	Saponin (MW=1442) Rt=15min	Saponin (MW=1554) Rt=16min	Vaccaroside E (MW 1422) Rt=16min
CC- 9-10	*	---	20%	9%	3%	4%	5%
CC-12	---	*	10%	9%	---	(22%)**
CC-13	---	---	---	---	---	6%	6%

Identified compounds with Retention times (Rt) above 20 min.

Fraction	Saponin (MW 1538) Rt=20min	Saponin (MW 1596) Rt=21min	Vaccaroside G (MW 1406) Rt=26min	Segetoside I (MW 1464) Rt=27min (Rt=21 min)	Segetoside I Ac (MW 1506) Rt=30min	Segetoside H (MW=1448) Rt=31min
CC- 9-10	---	---	---	---	---	---
CC-12	---	10%	---	36%	---	---
CC-13	---	16%	---	60%	---	---
CC-14	---	23%	---	68%	---	---
CC-15	---	23%	---	58%	---	---
CC-16	---	23%	traces	48%	---	---
CC-17	traces	20%**	14%**	48%	---	---
CC-18	7%	---	26%	17%	13%	9%
CC-19	27%	traces	67%	7%	---	---
CC-20	16%	---	27%	traces	16%	---
CC-22	----	---	10%	---	---	69%

Note: Percentage values represent relative amounts to other saponins in the same fraction (expressed as Area %)

*present in significant amounts **overlapping of peaks

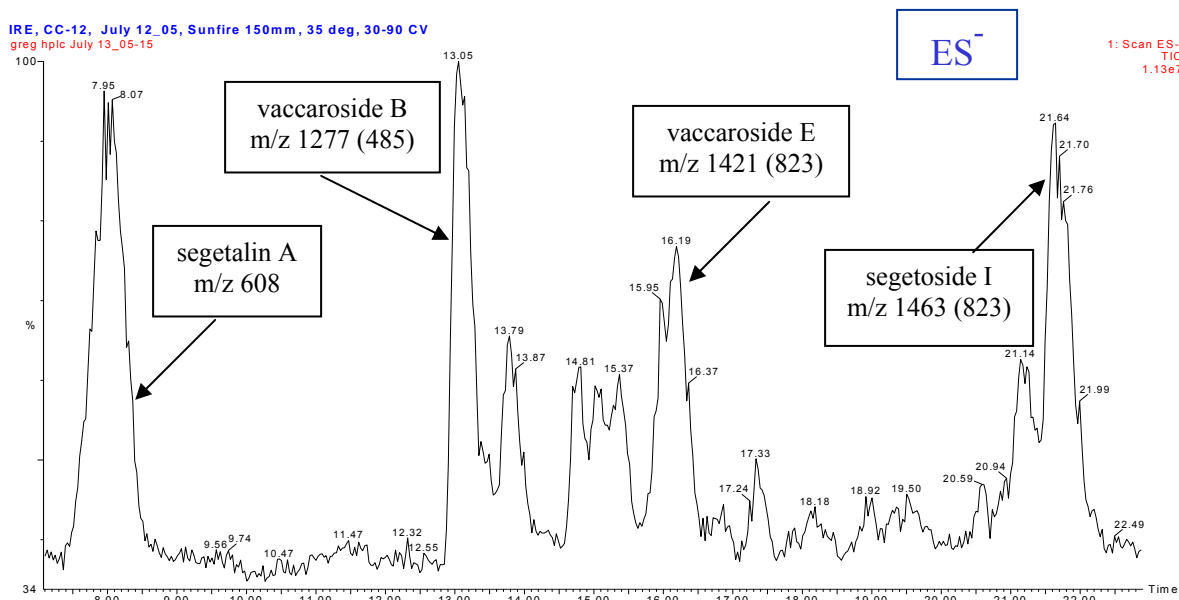

Figure 4.13. Total ion chromatogram of fraction CC-12 showing the main identified saponins and cyclopeptide segetalin A.

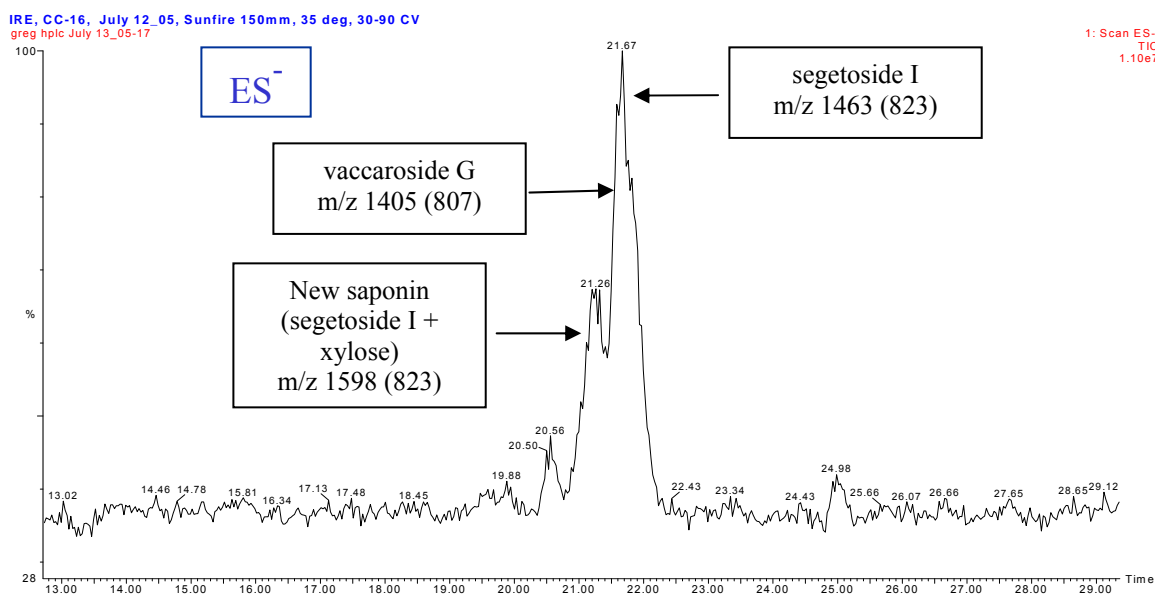

Figure 4.14. Total ion chromatogram of fraction CC-16 showing segetoside I, vaccaroside G, and a newly identified saponin, all overlapped under one signal.

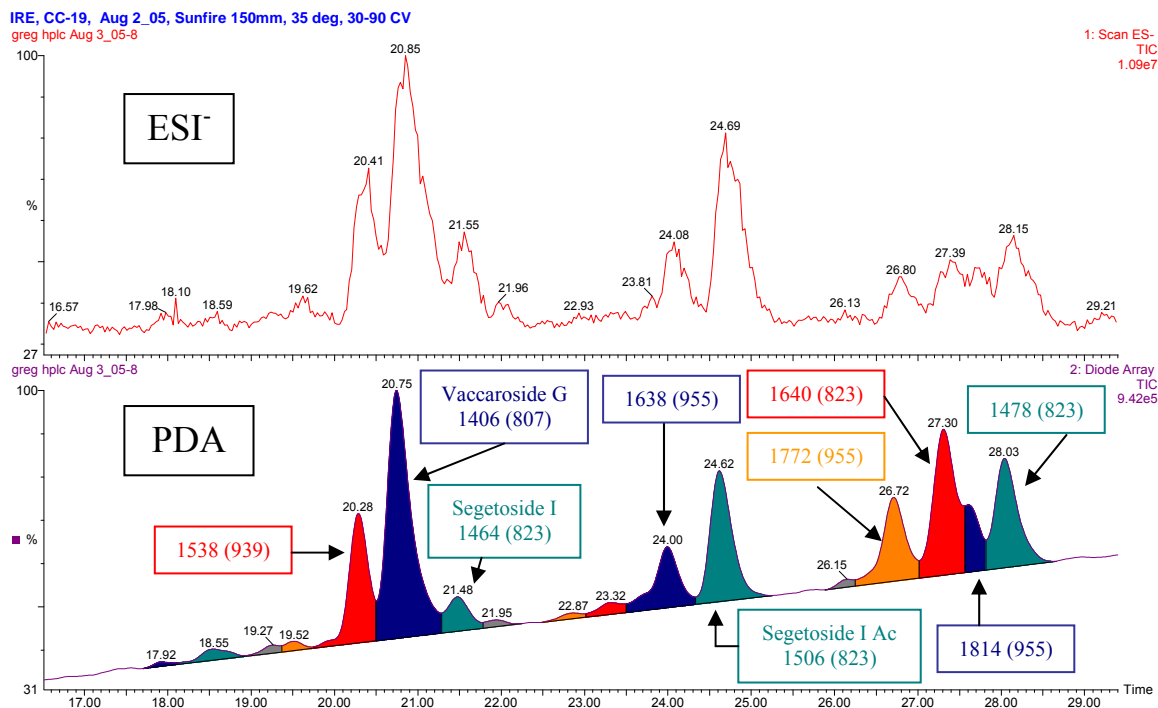

Figure 4.15. HPLC-PDA-MS chromatogram of fraction CC-19 showing identified known and unknown saponins.

All saponin containing fractions were tested for cytotoxic activity against the cancer cell lines WiDr, MDA-MB-231, NCI-417, and PC-3, and the human fibroblast normal cell line CRL-2522. Dose-response curves of CC fractions against individual cell lines showed a consistent pattern of cytotoxic activities (Fig. 4.16). Additionally, all saponin-containing fractions, but in particular fractions CC-18, CC-19, CC-20 and CC-21 showed enhanced cytotoxicity to human breast cancer cell line MDA-MB-231. These observations were confirmed when the dose-response curves of each individual fraction were compared against all cell lines (Fig. 4.17).

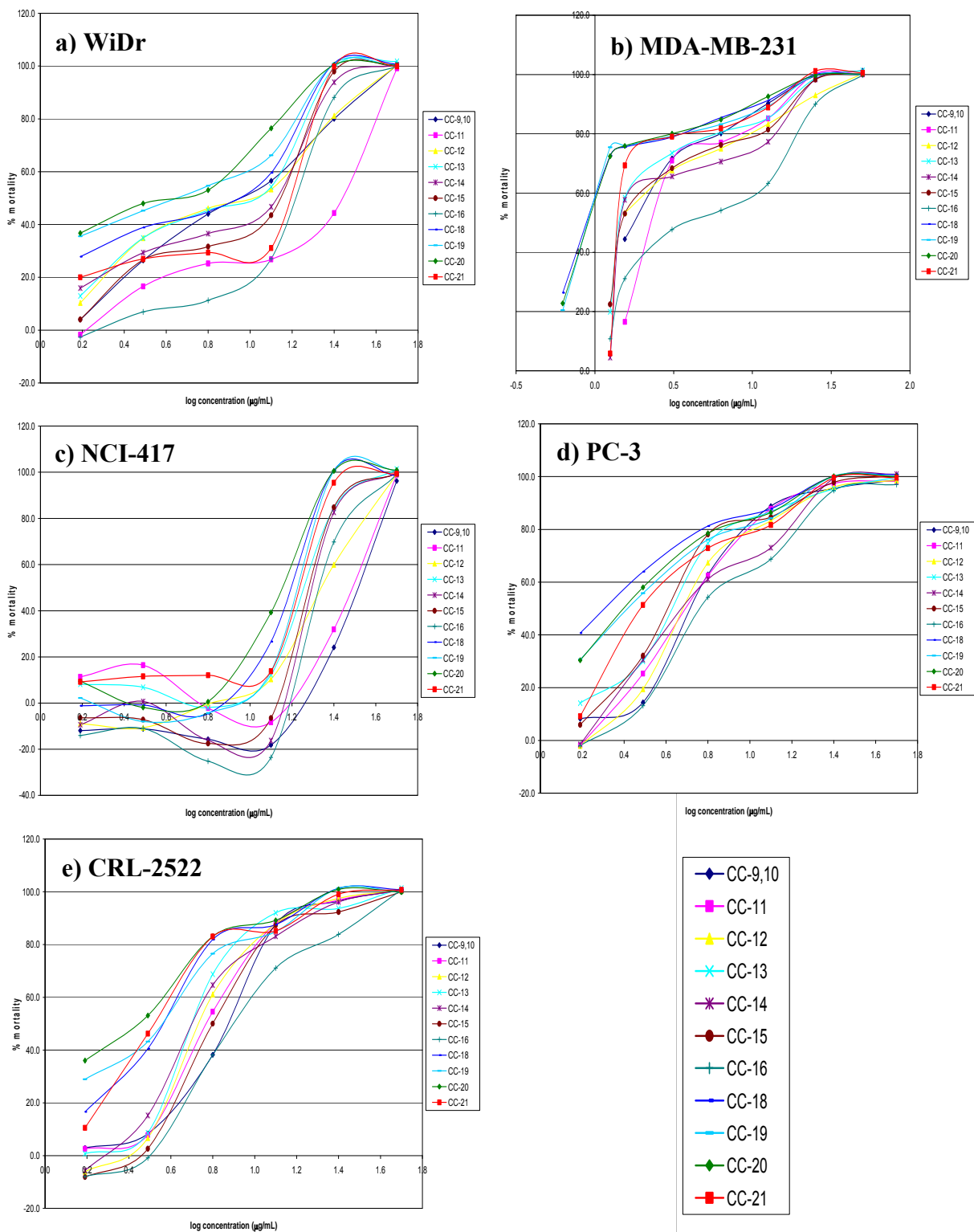

Figure 4.16. Inhibition induced by fractions collected from the chromatographic separation of a saponin mixture (SPM) from the seed of *Saponaria vaccaria* L. at different concentrations ($n \geq 3$) on human cancer cell lines (a) WiDr, colon; (b) MDA-MB-231, breast; (c) NCI-417, lung; (d) PC-3, prostate; and (e) human normal fibroblast cell line CRL-2522.

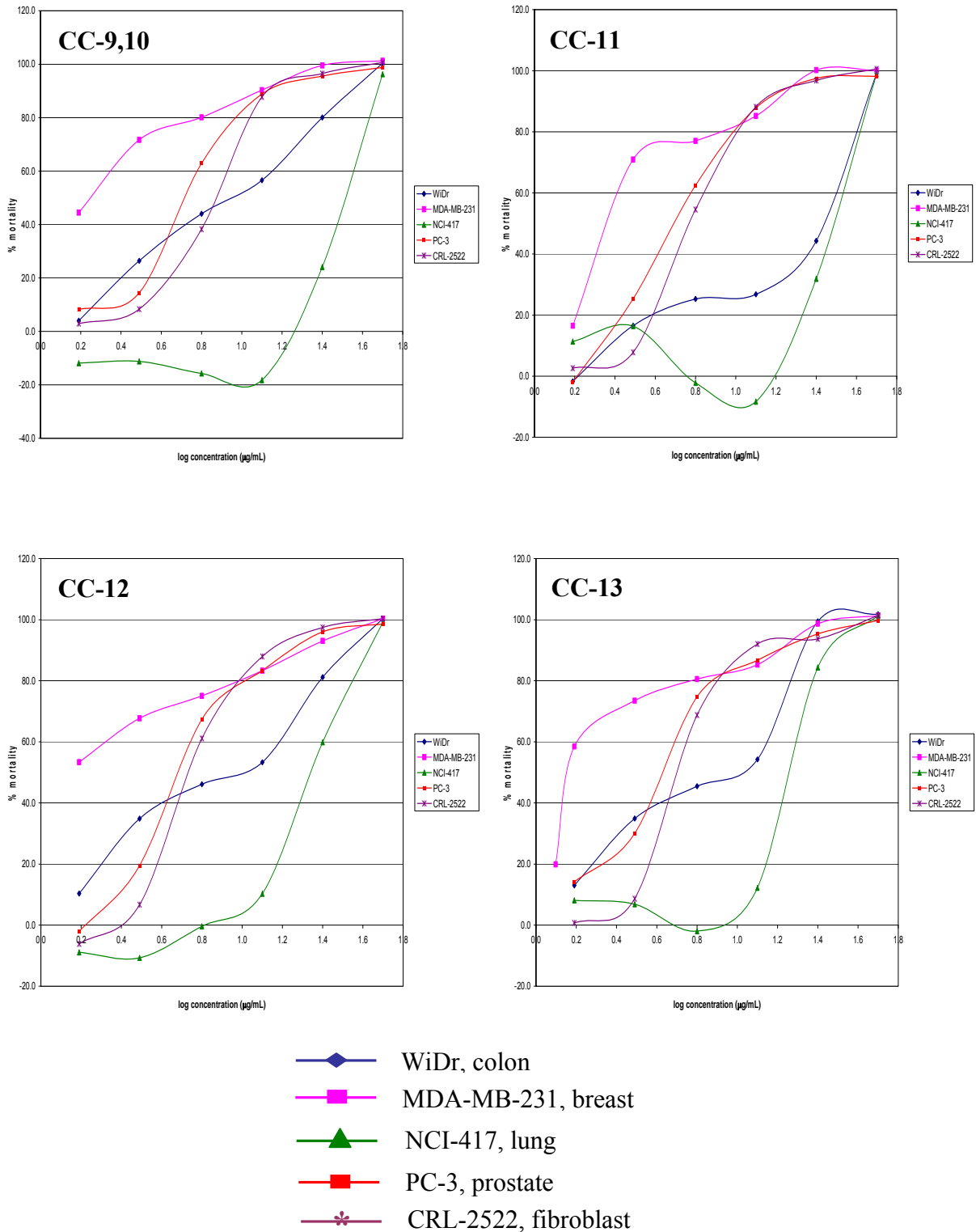

Figure 4.17. Inhibition induced by individual fractions collected from the chromatographic separation of a saponin mixture (SPM) from the seed of *Saponaria vaccaria* L. at different concentrations ($n \geq 3$) on five human cell lines.

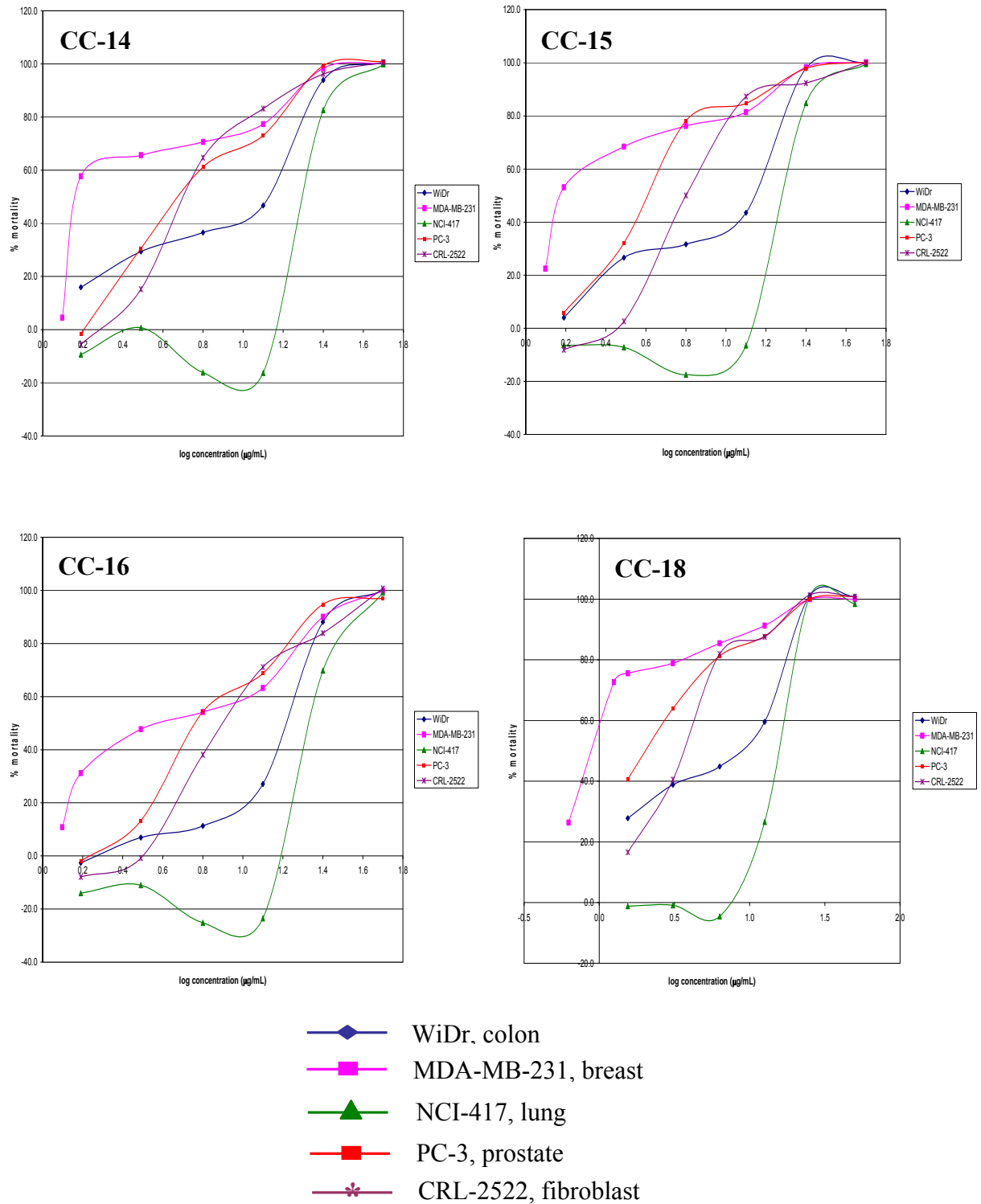

Figure 4.17. (Continued) Inhibition induced by individual fractions collected from the chromatographic separation of a saponin mixture (SPM) from the seed of *Saponaria vaccaria* L. at different concentrations ($n \geq 3$) on five human cell lines.

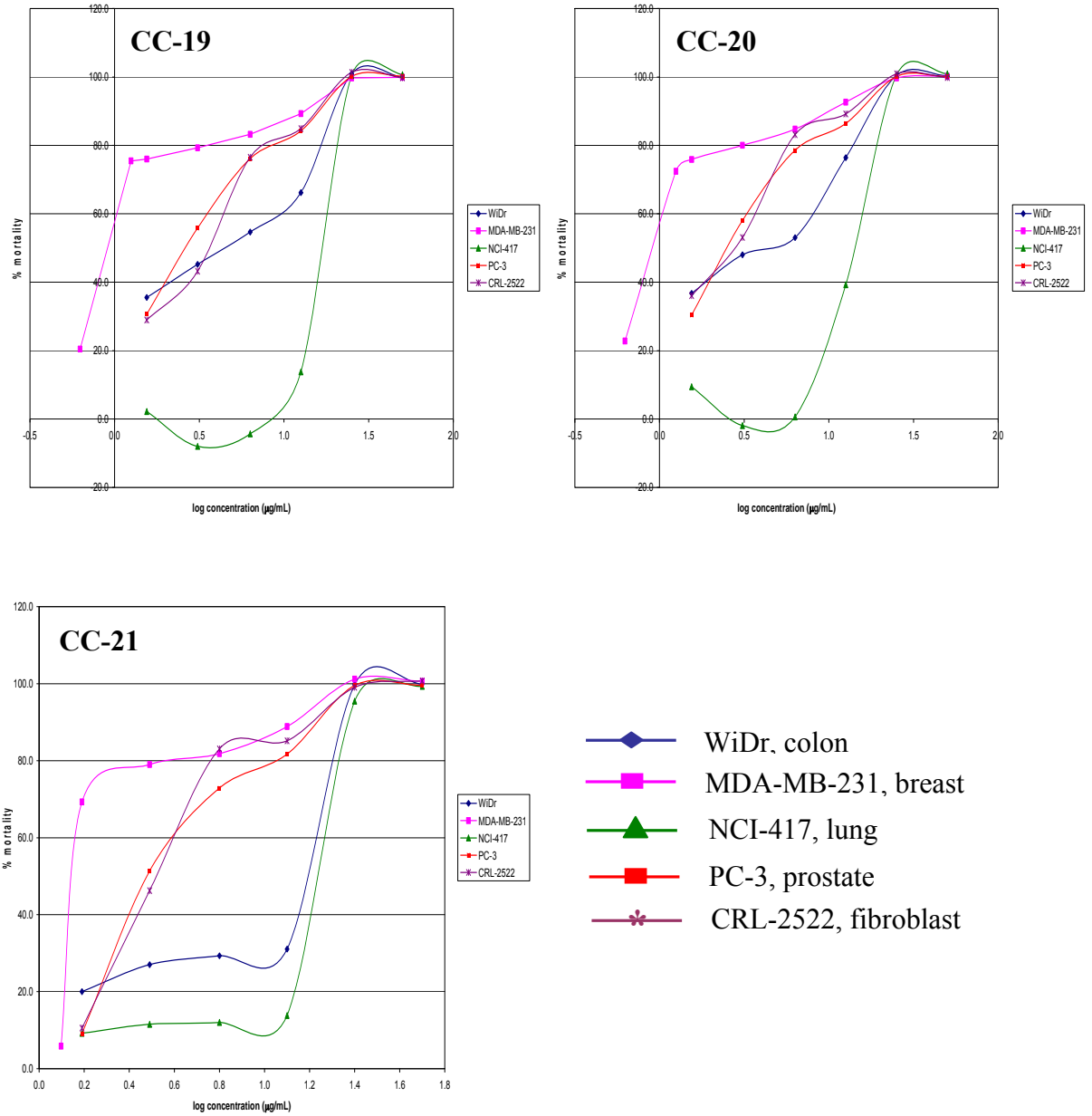

Figure 4.17. (Continued) Inhibition induced by individual fractions collected from the chromatographic separation of a saponin mixture (SPM) from the seed of *Saponaria vaccaria* L. at different concentrations ($n \geq 3$) on five human cell lines.

The high cytotoxic activity (low IC_{50} values) exerted by the saponins over the breast cancer cell line MDA-MB-231 in comparison with the other cell lines is remarkable. While toxicity in PC-3 was also moderately high, values were similar to those from the normal fibroblast cell line CRL-2522. The other two cell lines WiDr and NCI-417 only showed cytotoxic results at concentrations that harmful (toxic) doses would be needed for the treatment of those forms of cancer. Cisplatin, an anticancer drug used for the treatment of a variety of tumors (metastatic testicular and ovarian tumors, advanced bladder carcinoma, breast cancer, head and neck carcinoma, lung carcinoma) was used as a positive control. It is noteworthy that the action of these saponins (or the mixture of them) on the breast cancer cell line is more toxic than the control cisplatin.

The results from this study also suggest that certain cell lines (WiDr, NCI) are more resistant to the cytotoxic action of the *S. vaccaria* bisdesmosidic saponins, whereas for others (MDA-MB-231, PC-3, and maybe CRL-2522), exposure to small amounts of these saponins can be lethal. IC_{50} values obtained from dose-response curves of all CC fractions and cisplatin are presented in Table 4.10, and graphically on Fig. 4.18.

Table 4.10. IC₅₀ values (µg/mL) obtained from a dose-response curve of semi-pure saponins extracted from *Saponaria vaccaria* L. seed, tested *in vitro* against the human cancer cell lines WiDr (colon), MDA-MB-231 (breast), NCI-417 (lung) and PC-3 (prostate) and the human fibroblast normal cell line CRL-2522 using the MTT bioassay.

Sample	Cell line				
	WiDr	MDA-MB-231	NCI-417	PC-3	CRL-2522
CC 9-10	8.8	1.8	32.4	5.2	7.4
CC-11	26.9	2.4	30.2	5.0	5.9
CC-12	9.1	1.5	21.9	4.9	5.5
CC-13	9.1	1.8	18.1	4.3	5.0
CC-14	13.2	1.3	20.0	5.1	5.2
CC-15	13.6	1.8	19.3	4.1	6.3
CC-16	16.6	3.2	21.4	5.9	8.2
CC-18	5.9	0.9	15.6	2.5	3.6
CC-19	4.5	0.9	16.8	2.7	3.6
CC-20	4.2	0.9	14.2	2.5	2.7
CC-21	15.2	1.3	17.1	3.0	3.3
Cisplatin [†]	8.9 (2.7)	26.9 (8.1)	12.0 (3.6)	9.4 (2.8)	11.8 (3.6)

Note: IC₅₀ values for MDA-MB-231 were calculated using concentrations between 0.6 – 50 µg/mL for accurate measurements.

[†] Cisplatin preparations are expressed in µM (µg/mL)

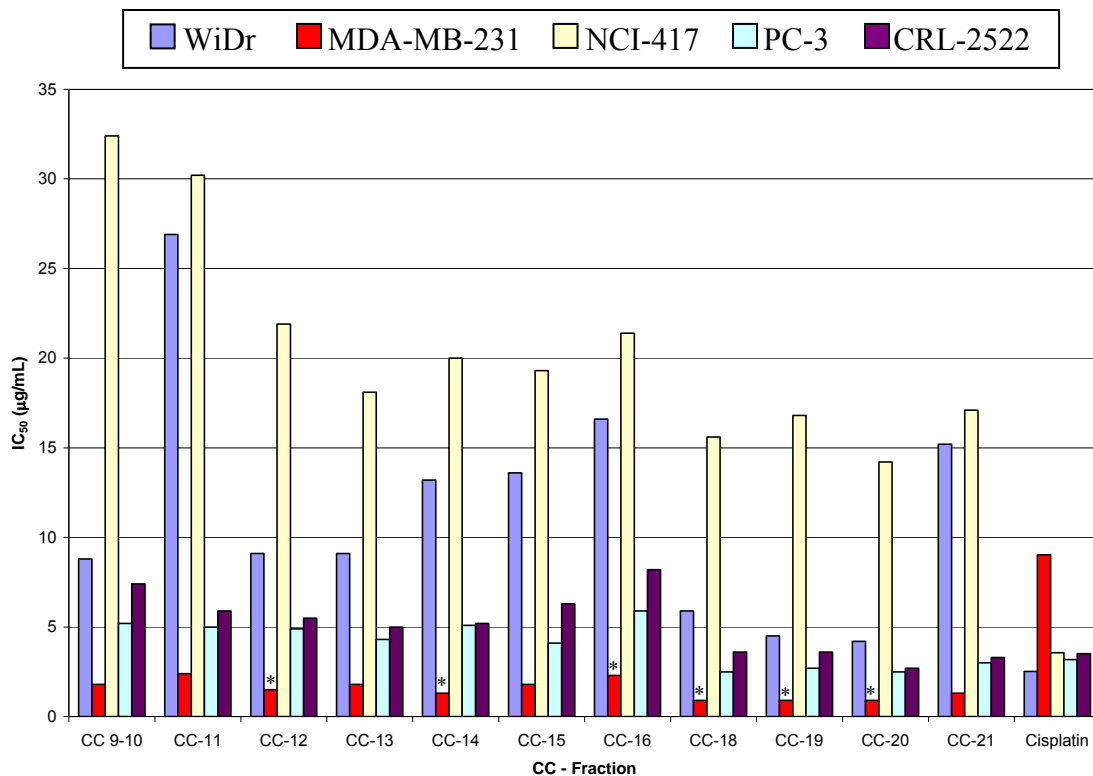

Note: Significant values for CC-fraction treatments are denoted by * for $P < 0.05$ (t -test) in comparison to Cisplatin. ($n \geq 3$).

Figure 4.18. Comparison of IC_{50} values of fractions from the chromatographic separation of *Saponaria vaccaria* L. saponin extract on four human cancer cell lines WiDr (colon), MDA-MB-231 (breast), NCI-417 (lung), PC-3 (prostate), and the human fibroblast normal cell line CRL-2522.

4.5. Evaluation of selected drugs to be used as potential positive controls in the

MTT assay

In order to select commercially available drugs to be used as positive controls for the bioassays besides cisplatin, solutions of verapamil, pimozone, a 1:1 mixture of verapamil and pimozone, and the anticancer drugs 5-fluorouracil (5-FU) and vinblastine

(VLB) were prepared and exposed to WiDr, MDA-MB-231, NCI-417 and CRL 2522 cell lines. Results are shown in Table 4.11.

Table 4.11. IC₅₀ values (μM) of four commercially available drugs against three human cancer cell lines WiDr, MDA-MB-231, NCI-417 and the human fibroblast normal cell line CRL-2522.

Cell line Drug	WiDr (colon)	MDA-MB-231 (breast)	NCI-417 (lung)	CRL-2522 (fibroblast)
IC ₅₀ (μM)				
Verapamil	90.67 ± 7.001	>120	>120	N/D
Pimozide	8.84 ± 1.702	20.22 ± 2.068	13.46 ± 2.060	18.23 ± 0.722
Verapamil + pimozide	9.40 ± 1.457	17.19 ± 1.855	15.60 ± 2.139	N/D
5-Fluorouracil[†]	17.03 ± 3.714	12.50 ± 0.100	47.77 ± 25.292	>120
Vinblastine[‡]	< 3.75	< 3.75	< 3.75	29.83 ± 11.26
	< 3.75	< 3.75	< 0.004	
	< 0.004	< 0.004		

Note: The values expressed represent the mean ± S.D. (n≥3). N/D = data not calculated.

[†] Some results showed IC₅₀ values higher than max. concentration tested (120 μM)

[‡] Vinblastine results are discussed below

Pimozide has been used in the management of chronic schizophrenic patients (Rathbone and McMonagle, 2000). It has also been shown in our laboratory that the synergistic effect of a potent calmodulin antagonist (pimozide) with a calcium channel blocker (verapamil) inhibited proliferation of human colon cancer cell lines using the human tumor clonogenic assay (Wong, 1986). However, using the MTT method, the mixture of verapamil and pimozide showed results corresponding to pimozide alone

since verapamil did not show any cytotoxicity. Pimozide toxicity was greater against WiDr ($IC_{50} = 8.84 \mu\text{M}$ or $4.1 \mu\text{g/mL}$), then against NCI-417 (IC_{50} value $13.46 \mu\text{M}$ or $6.2 \mu\text{g/mL}$) and least toxic against MDA-MB-231 ($IC_{50} = 20.22 \mu\text{M}$ or $9.3 \mu\text{g/mL}$). The IC_{50} value for pimozide against the normal fibroblast cell line was $18.23 \mu\text{M}$ or $8.4 \mu\text{g/mL}$. 5-FU showed intriguing data since results were quite contradictory. We speculate that preparation and storage conditions of the drug were not suitable, and optimal conditions need to be investigated. Most intriguing were the results obtained from VLB since at the range of concentrations tested ($3.75\text{--}120 \mu\text{M}$), only the two highest ones showed a dose-response mortality of cells. Due to these results, a bioassay was conducted using very low concentrations of this drug, showing that even at the lowest concentration tested (4 nM) results were still the same (Table 4.12). Dose-response graphs were generated for comparative purposes (Fig. 4.19). Examination under the microscope showed that drug treated cells were still alive but not dividing. This would suggest that below the toxic concentration (approximately $60 \mu\text{M}$) cells were still viable, perhaps in the “resting state”. This was an unexpected dose-response result and no similar or related data was found in the literature, other than a study suggesting that tumor cells suspended in tissue culture medium can alter tumor cell kinetics causing an effect in tumor sensitivity to cell cycle specific drugs (i.e. vinca alkaloids), but not to non-cycle specific drugs (Durkin *et al.*, 1979). The normal cell line CRL-2522 did respond in a typical dose-response fashion for the three highest concentrations allowing the calculation of an IC_{50} value of $29.83 \mu\text{M}$ ($27.1 \mu\text{g/mL}$). However, at concentrations of $30 \mu\text{M}$ and below, cell viability did not seem to be affected. Further examination of the literature and experiments are needed in order to rationalize these results.

Table 4.12. Percentage mortality of three cancer cell lines WiDr, MDA-MB-231, and NCI-417, and a normal fibroblast cell line CRL-2522 when tested against various concentrations of vinblastine.

Concentration (μM)	Percentage Mortality (%)			
	WiDr (colon)	MDA-MB-241 (lung)	NCI-417 (lung)	CRL-2522 (fibroblast)
120	96.8	91.9	92.0	94.9
60	82.9	81.7	97.8	54.5
30	63.6	64.3	91.0	37.2
15	58.7	57.2	96.4	34.2
7.5	63.4	56.9	91.8	37.0
3.75	63.1	56.8	87.3	33.9
1.875	59.6	53.9	81.1	
0.938	59.5	47.8	87.1	
0.469	58.5	51.6	85.5	
0.234	56.4	50.9	83.7	
0.117	58.6	47.2	75.3	
0.059	57.5	50.0	83.9	
0.029	59.0	48.4	82.9	
0.015	60.1	50.0	81.9	
0.007	59.2	38.7	73.7	
0.004	58.4	41.3	77.7	

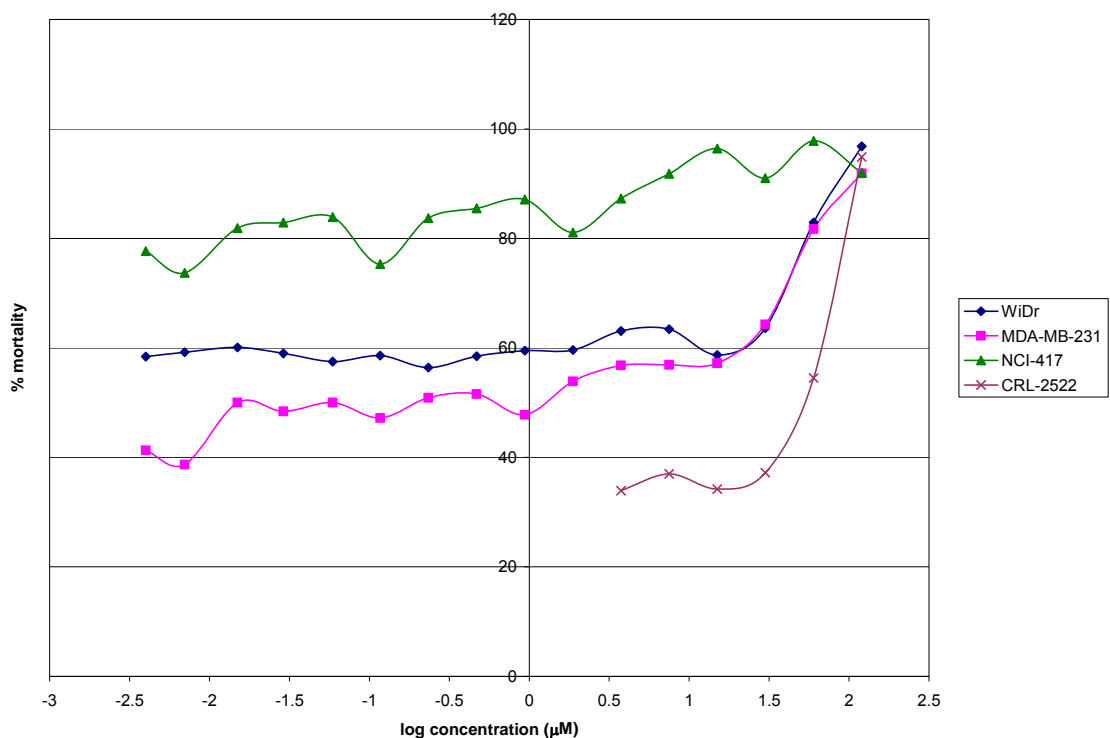

Figure 4.19. Mortality induced by Vinblastine at different concentrations (n=3) on human cancer cell lines WiDr (colon), MDA-MB-231 (breast), NCI-417 (lung) and human fibroblast normal cell line CRL-2522.

4.6. Chemical modifications of saponins in relation to their cytotoxic activity

Structural changes of secondary metabolites by chemical modifications are commonplace in the chemistry laboratory in an attempt to improve the physical and/or biological activities of the original leads.

Three minor chemical modifications on the structure of saponin-containing fraction CC-19 were performed: a sodium borohydride (NaBH_4) reduction of the aldehydic group; a methylation reaction with diazomethane (CH_2N_2) on the carboxylic group of the C-3-*O*-glucuronic acid, and a de-acetylation reaction with

(mono)ethanolamine (MEA) (Fig. 4.20). Careful study of the HPLC-PDA-MS of the reaction products provided enough information to account for the percentage conversion of CC-19 into the corresponding final products.

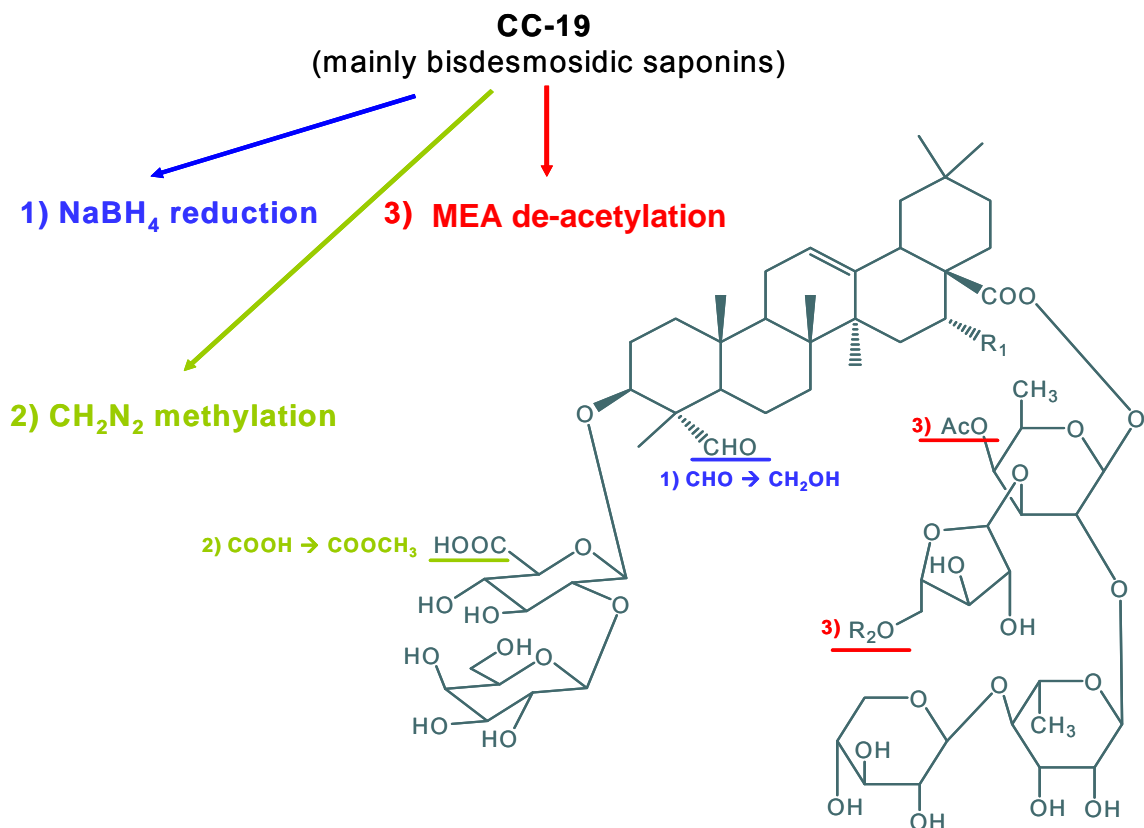
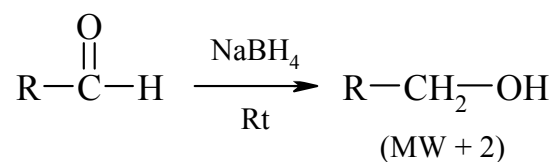

Figure 4.20. A study of the structure-activity relationships of saponins with sodium borohydride (NaBH_4), diazomethane (CH_2N_2) and (mono)ethanolamine (MEA).

4.6.1. Sodium borohydride reduction



CC-19 (40 mg) was dissolved in 50% MeOH (5 mL) with heat and sonication. After saponins were dissolved, the solution was cooled down in an ice/water bath and NaBH₄ (5 mg) was immediately added. Solution was then stirred at room temperature for 30 min., quenched with acetone (Me₂CO), and then diluted to a concentration of 20% MeOH. The reaction product was filtered through a C₁₈ cartridge and saponins were retrieved with 100% MeOH after pre-washes with water and 20% MeOH.

HPLC-PDA-MS analysis of the reaction product showed approximately 50% conversion of the aldehyde into the alcohol (data not shown). In a consequent reduction reaction, reduction of saponins was achieved with excess NaBH₄ and longer reaction times (approx. 2h).

4.6.2. Methylation reaction with diazomethane (CH₂N₂)

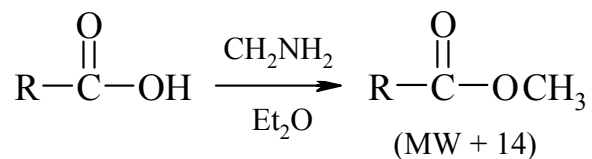

Diazomethane was prepared from Diazald (Aldrich Chemical Co., Milwaukee, Wisc.) using their Diazald Kit. CC-19 (35 mg) was dissolved in 90% MeOH (2.5 mL) and diazomethane (approx. 1 mL) was added until the yellow colour of excess

diazomethane persisted for 15 min. The reaction was kept at room temperature until CH_2N_2 evaporated.

HPLC-PDA-MS analysis (Fig. 4.21) showed three signals (bottom chromatogram) at Rt 25.62, 26.27, 26.53 and 27.22 min corresponding to the methylated saponins 1420 (1406+14), 1478 (1464+14) and 1552 m/z (1538+14), respectively.

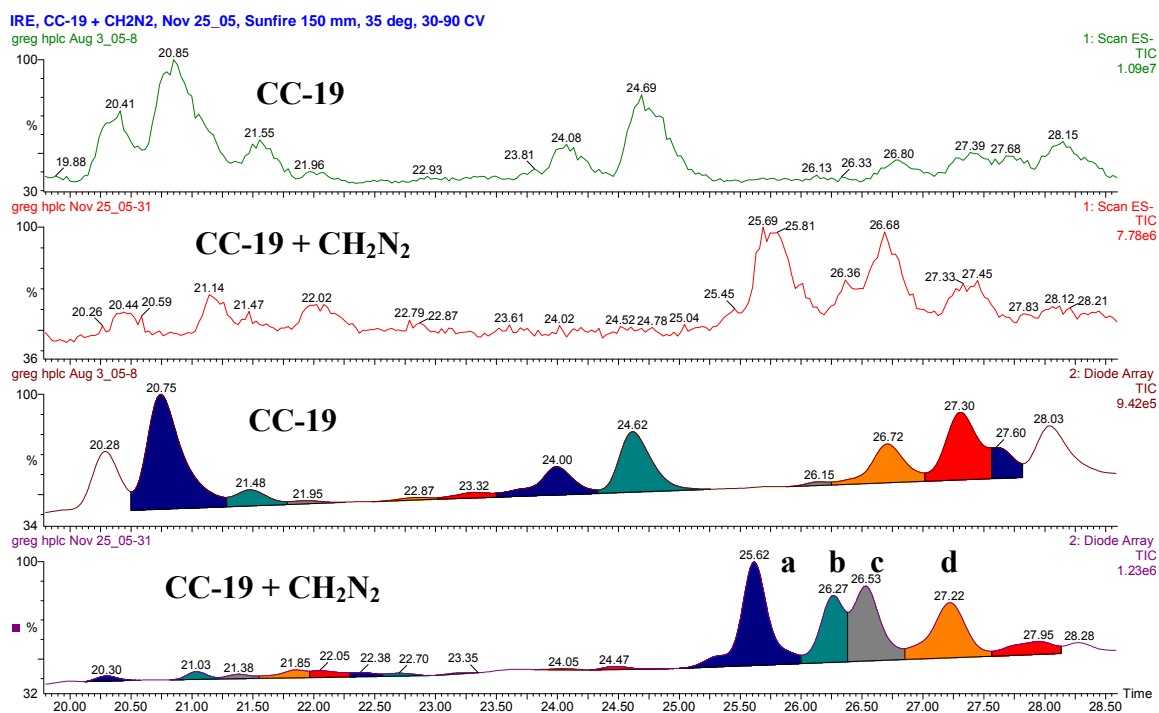
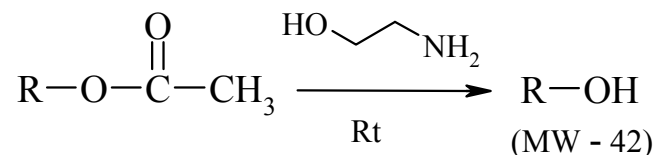

Figure 4.21. Comparison of chromatograms of saponin mixture CC-19 with its corresponding methylated products. a, b, c, and d correspond to the methylated saponins 1420 (1406+14), 1478 (1464+14) and 1552 m/z (1538+14), respectively.

4.6.3. De-acetylation reaction with (mono)ethanolamine (MEA)



CC-19 (40 mg) was dissolved in 80% MeOH (30 mL) and adjusted to pH 9 with MEA. Citric acid (4 mg) was then added and the solution was refluxed for 2 h. The reaction mixture was then neutralized with tartaric acid and diluted with excess water (20 mL). A chromatographic separation was performed using a pre-packed 200 mg C₁₈ column and washing the mixture first with water, and retrieving the saponins with 100% MeOH. The MeOH extract was then evaporated until dryness and analysed by HPLC-PDA-MS.

Figure 4.22 shows the chromatograms generated by HPLC-PDA-MS. Using single ion extraction from the total ion chromatogram it was possible to identify the de-acetylated saponins. Table 4.13 shows the assignation of peaks as compared to the parent saponin.

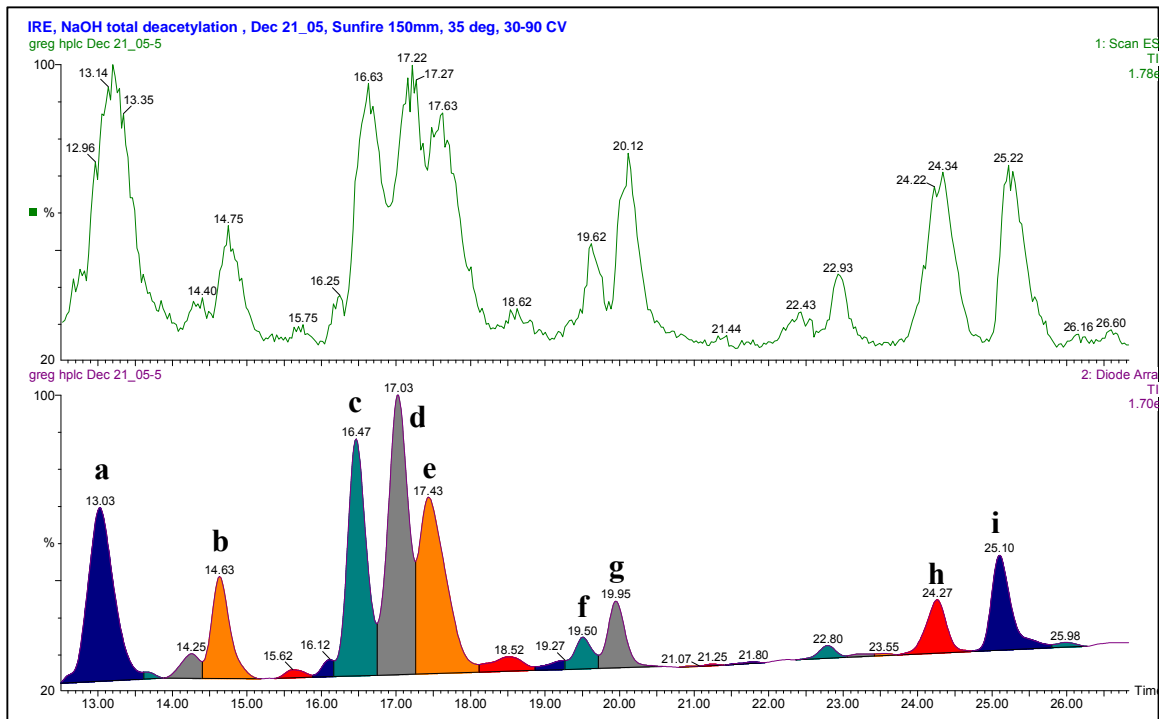

Figure 4.22. LC-MS chromatogram of the de-acetylation reaction of saponin-containing fraction CC-19. Peaks labeled a–i correspond to de-acetylated saponins which showed a decrease of m/z 42 or 84 from the parent saponin, corresponding to the loss of either one or two acetyl groups, respectively.

Table 4.13. Possible relationship of de-acetylated reaction products from corresponding parent saponin.

Peak	Rt (min)	MW	Parent saponin (MW)	Corresponds to
a	13.03	1380	1422 – 1 Ac or	Vaccaroside E or
			1464 – 2 Ac	Segetoside I
b	14.63	1688	1772 – 2 Ac	Unknown
c	16.47	1688	1772 – 2 Ac	Unknown
d	17.03	1394	1478 – 2 Ac	Unknown
e	17.43	1364	1406 – 1 Ac	Vaccaroside G
f	19.50	1554	1638 – 2 Ac	New saponin
g	19.95	1422	1464 – 1 Ac or	Segetoside I or
			1506 – 2 Ac	Segetoside I Acetate
h	24.27	1538*	Not detected in CC-19	New saponin
i	25.10	1406 *	1406 or	Vaccaroside G or
			1448 – 1 Ac	Segetoside H

*The corresponding parent saponins were not detected in CC-19 or they were probably masked under a larger signal.

The cytotoxic activity of the chemically modified saponins was tested on WiDr, MDA-MB-231, NCI-417, PC-3 and CRL-2522 cell lines using CC-19 as a control for comparison. Dose-response curves were generated and are presented in Fig. 4.23 and Fig. 4.24. Fraction CC-19 showed the highest cytotoxicity overall, while the chemical derivatization products showed varied results depending on the cell line. When the responses of each individual fraction were compared on all cell lines, it was evident the enhanced cytotoxicity exerted on MDA-MB-231 (breast) over the other cell lines.

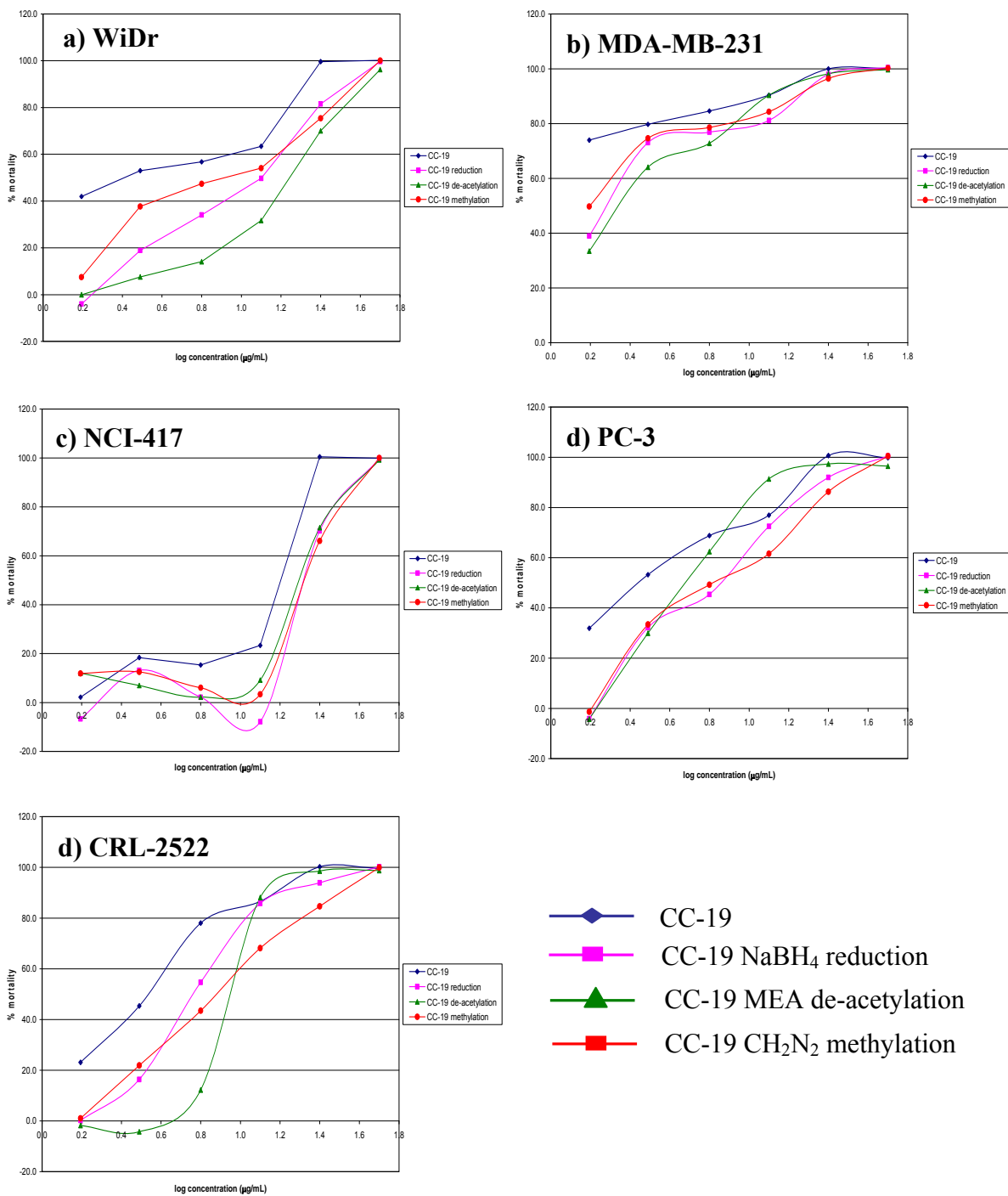

Note: error bars have been omitted for clarity.

Figure 4.23. Inhibition induced by bisdesmosidic saponin-enriched fraction CC-19 and corresponding chemical derivatization products on (a) human colon cancer cell line WiDr, (b) human breast cancer cell line MDA-MB-231, (c) human lung cancer cell line NCI-417, (d) human prostate cancer cell line PC-3, and (e) human fibroblast normal cell line CRL-2522.

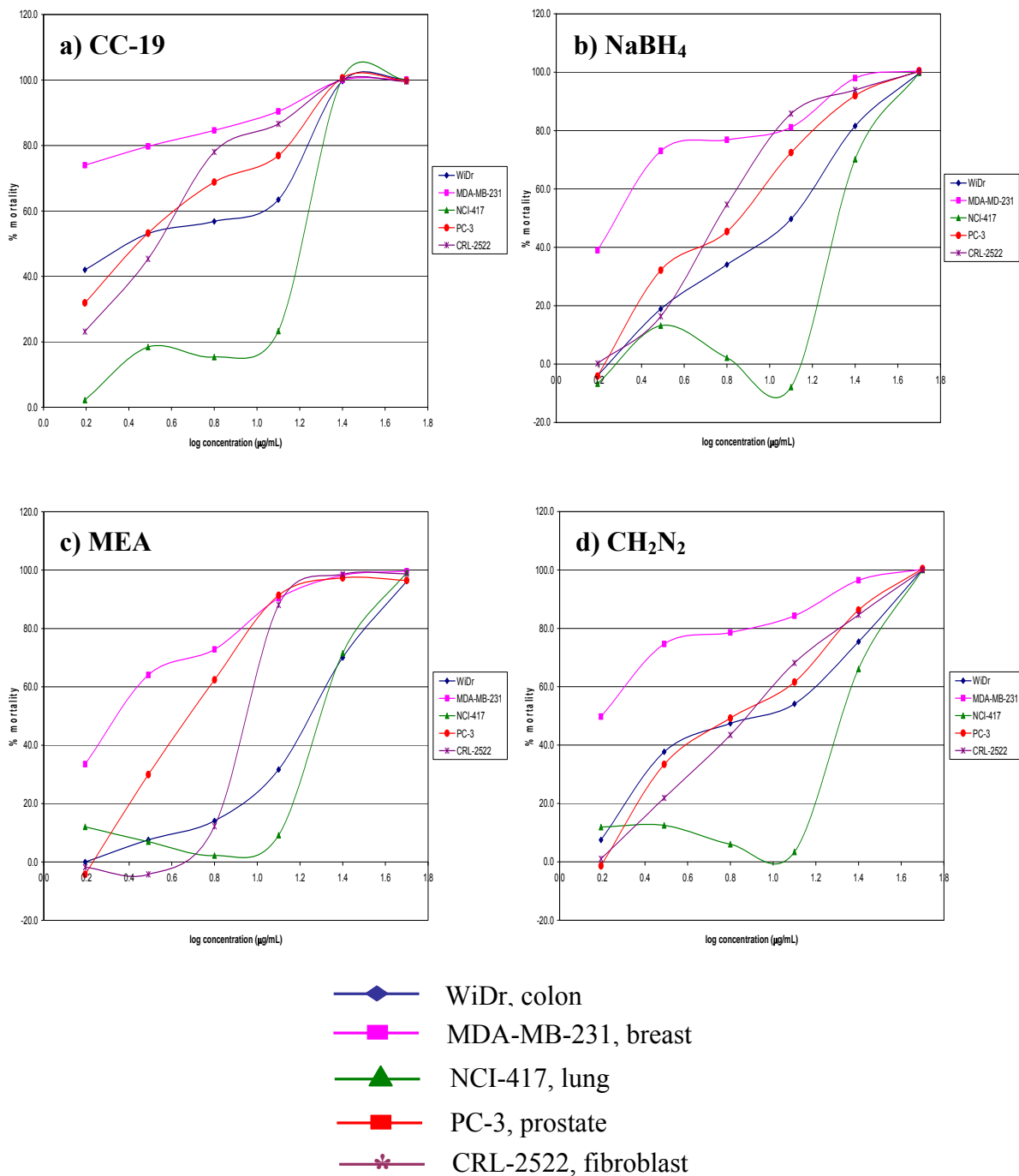

Note: error bars have been omitted for clarity.

Figure 4.24. Inhibition induced by the reaction products of the bisdesmosidic saponin-enriched fraction CC-19 upon treatment with diazomethane (CH₂N₂) on five human cell lines.

In summary, CC-19 alone is more potent than its corresponding modified structures on all cell lines studied, but CC-19 showed no enhanced selectivity on any cell line, including control CRL-2522. However, all chemically modified products showed enhanced selectivity on MDA-MB-231 and the de-acetylated product also showed enhanced selectivity on PC-3 (all compared to CRL-2522).

Additional cytotoxic activities were calculated for CC-19, its chemically modified structures and cisplatin (positive control) on human breast cancer cell line Hs578 T and its normal counterpart Hs578 BST (Fig. 4.25).

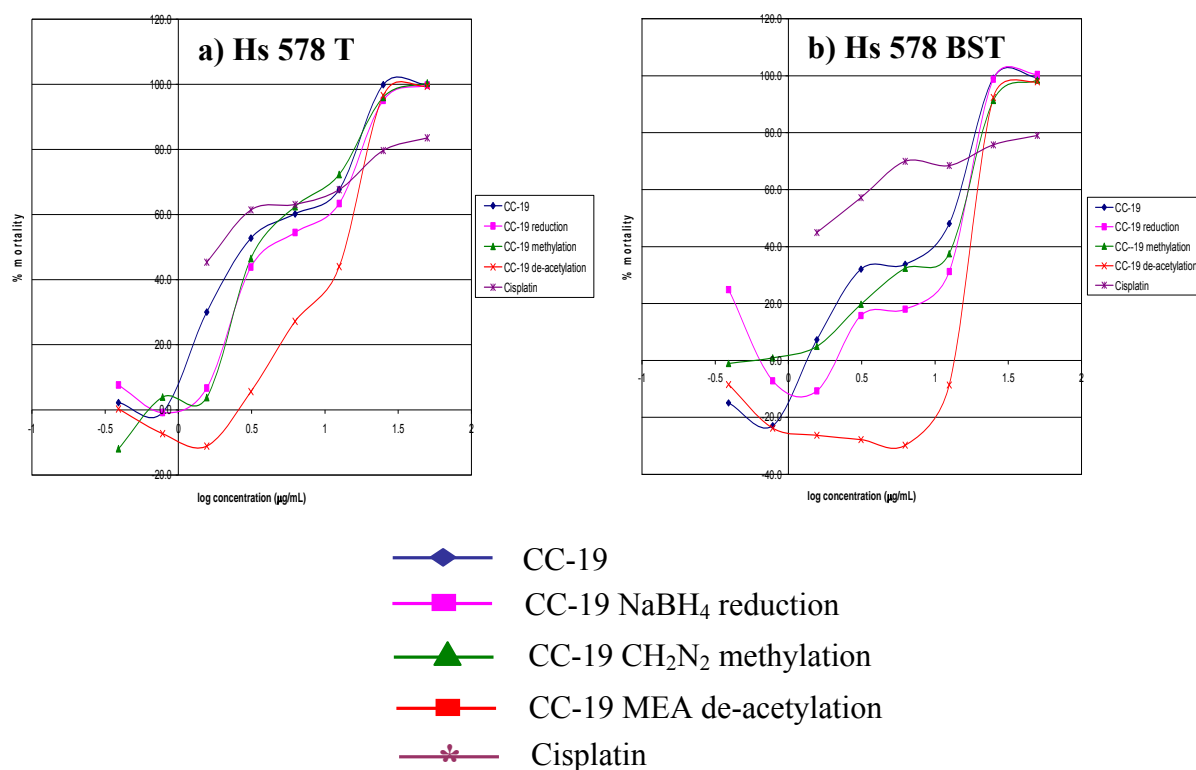

Figure 4.25. Inhibition induced by bisdesmosidic saponin-enriched fraction CC-19, its corresponding chemical modified structures and cisplatin on (a) human breast cancer cell line Hs578 T and (b) human breast normal cell line Hs578 BST.

IC₅₀ values were generated from all dose-response curves (Table 4.14, Fig. 4.26). As observed previously, cytotoxic activity of the corresponding reaction products was not enhanced when compared with unmodified CC-19. However, IC₅₀ values of CRL-2522, mainly from the de-acetylated and the methylated saponins, were significantly increased (less toxic). The other two cell lines (WiDr and NCI-417) did not show any significant differences. When comparing the dose-response graphs from Fig. 4.25, with the exception of the de-acetylated fraction, fraction CC-19 and its modified structures showed enhanced cytotoxicity over the cancer cell line. This difference in cytotoxic activity was not observed with cisplatin.

Table 4.14. IC₅₀ values from reaction products from the structural modifications of CC-19 against four cancer cell lines WiDr (colon), MDA-MB-231 (breast), NCI-417 (lung) and PC-3 (prostate) and human fibroblast normal cell line CRL-2522. (n≥6).

Fraction	WiDr	MDA-MB 231	NCI-417	PC-3
CC-19	6.66 ± 6.877 ^a	1.26 ± 0.341 ^{cdef}	16.00 ^k	2.88 ± 1.996
CC-19 + NaBH ₄ (reduction)	12.60 ± 0.300 ^{ab}	1.90 ^{cg}	21.00 ± 0.707 ^l	7.20 ± 2.970
CC-19 + MEA (de-acetylation)	14.57 ± 5.060	2.23 ± 0.208 ^{dhi}	19.80 ± 1.273 ^m	4.80 ± 0.141
CC-19 + CH ₂ N ₂ (methylation)	9.14 ± 9.597	1.68 ± 0.250 ^{ej}	20.65 ± 1.061 ⁿ	7.13 ± 5.601
Cisplatin	8.14 ± 8.444 ^b	8.68 ± 4.382 ^{fghij}	4.44 ± 4.487 ^{klmn}	3.42 ± 2.086
Fraction	CRL-2522	Hs578 T	Hs578 BST	
CC-19	3.66 ± 0.588 ^p	3.13 ± 1.613 ^q	13.20 ± 2.858 ^u	
CC-19 + NaBH ₄ (reduction)	5.80 ± 0.707	4.70 ± 0.212 ^f	15.20 ± 0.849 ^{vx}	
CC-19 + MEA (de-acetylation)	8.90 ^p	13.60 ± 1.131 ^{qs}	18.70 ± 0.778 ^{vy}	
CC-19 + CH ₂ N ₂ (methylation)	8.48 ± 3.859	3.50 ± 0.424 ^t	14.70 ± 1.131 ^z	
Cisplatin	7.33 ± 3.733	1.20 ± 0.789 ^{rst}	1.25 ± 0.789 ^{uxyz}	

Note: IC₅₀ values are expressed as mean ± S.E.M (*n* ≥ 6). Same letters within columns denote mean values which are significantly different (*t*-test *P* = 0.05)

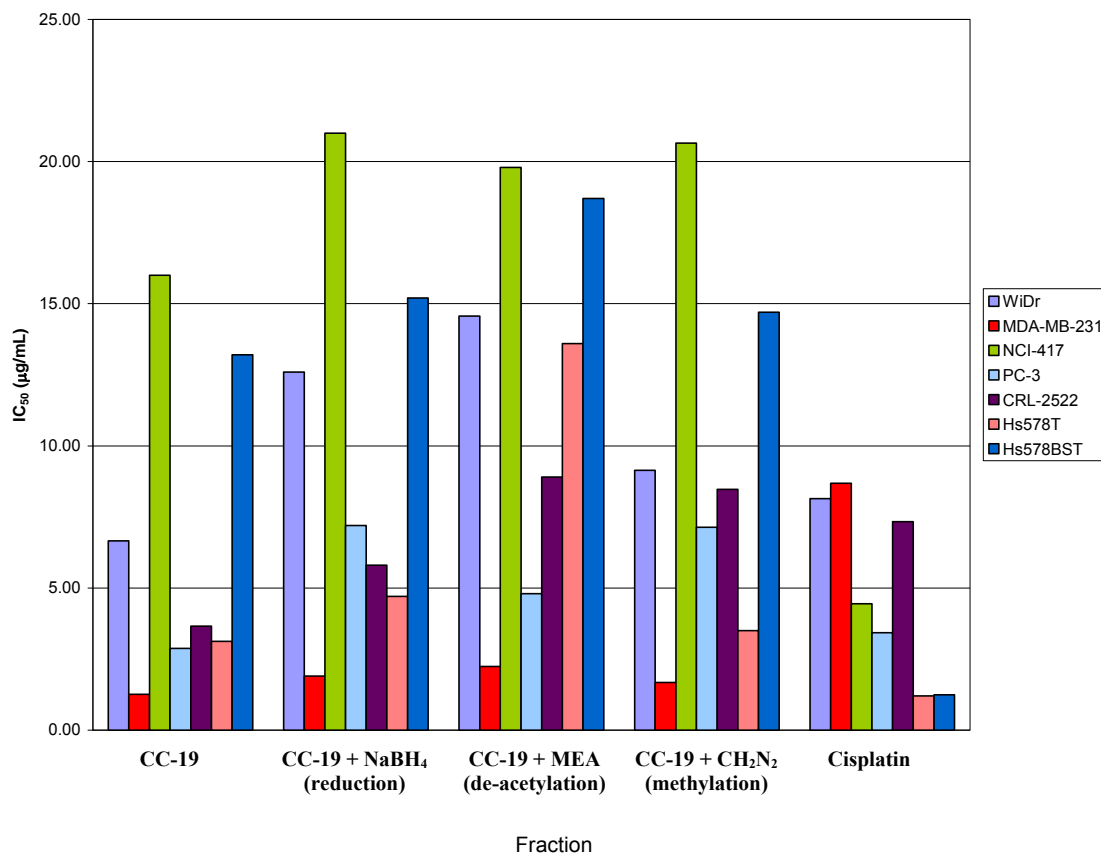

Figure 4.26. Cytotoxic comparison (IC_{50} values) of saponin-containing fraction CC-19 with its chemically modified reaction products (reduced, de-acetylated and methylated saponins) and cisplatin on five human cancer cell lines (WiDr, colon; MDA-MB-231, breast; NCI-417, lung; PC-3, prostate and Hs578 T, breast) and two human normal cell lines (CRL-2522, fibroblast and Hs578 BST, breast).

4.7. Preliminary studies of the mechanism of action (MOA) of *Saponaria vaccaria* saponins

It has been reported that apoptosis or programmed cell death (PCD) is the mechanism of action of many biologically active saponins extracted from other plant species (Haddad *et al.*, 2004; Hsu *et al.*, 2004; Yanamandra *et al.*, 2003; etc.).

In order to study the MOA of *S. vaccaria* saponins, nuclear staining of the breast cancer cells with propidium iodide (PI) and Hoechst 33342 was performed. Physical differences in size or morphology, disruption of cell membrane, or the presence of apoptotic bodies revealed by the staining of the nucleus in saponin treated cancer cells would suggest apoptosis as the MOA of these saponins.

PI intercalates into double-stranded nucleic acids. It is excluded by viable cells, but can penetrate cell membranes of dying or dead cells. Once the dye is bound to nucleic acids, its fluorescence is enhanced 20-30 fold. On the other hand, Hoechst 33342 DNA staining is a UV-excitable nucleic acid stain readily taken up by all cells. Its blue fluorescence is particularly bright in the condensed nuclei of apoptotic cells.

Saponin mixture CC-19 at four different concentrations (3, 10, 25 and 30 $\mu\text{g/mL}$) was used against MDA-MB-231 (breast cancer cell line) at different incubation times (0-48 h) and cells were then observed under a fluorescent microscope. The anticancer drug and apoptotic inducer cisplatin was used as a positive control, while the non-ionic surfactant Triton-X was used as the negative control.

4.7.1. Fluorescence microscopy studies

Microscopy studies were performed at the Plant Biotechnology Institute by Ms. Leah Deibert. Diagrams and photos were prepared by Dr. J. Balsevich. Control cells were carefully studied under the fluorescence and phase contrast microscope for morphology and staining patterns. All cells showed uniformity in these two aspects. A picture of the MDA-MB-231 cells stained with PI is shown in Fig. 4.27.

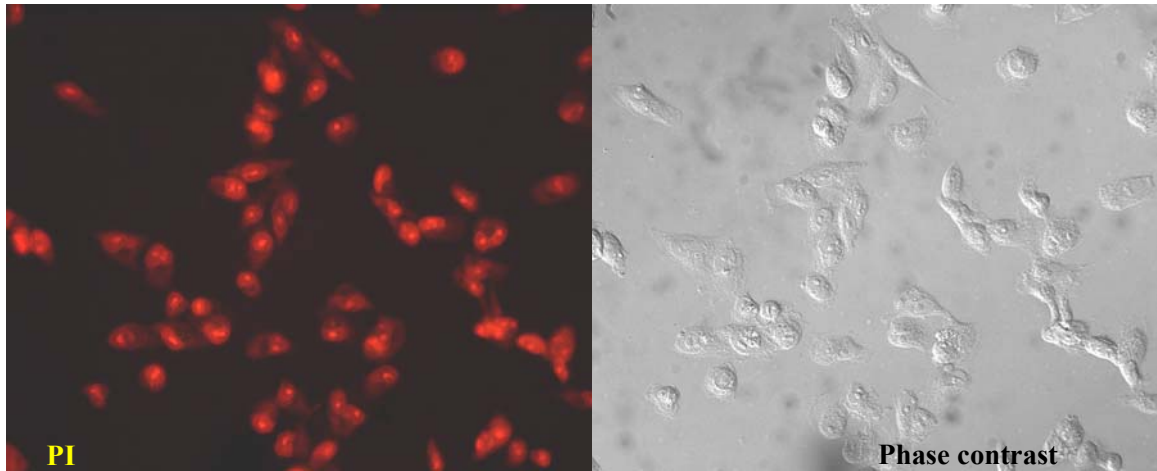

CONTROL

Figure 4.27. MDA-MB-231 cells used as control and treated with propidium iodide. No irregularities in morphology or size were detected. Photo courtesy of J. Balsevich.

Triton-X showed disruption of membrane integrity and cell death at all incubation times. No difference in fluorescence was detected among the cells (Fig. 4.28).

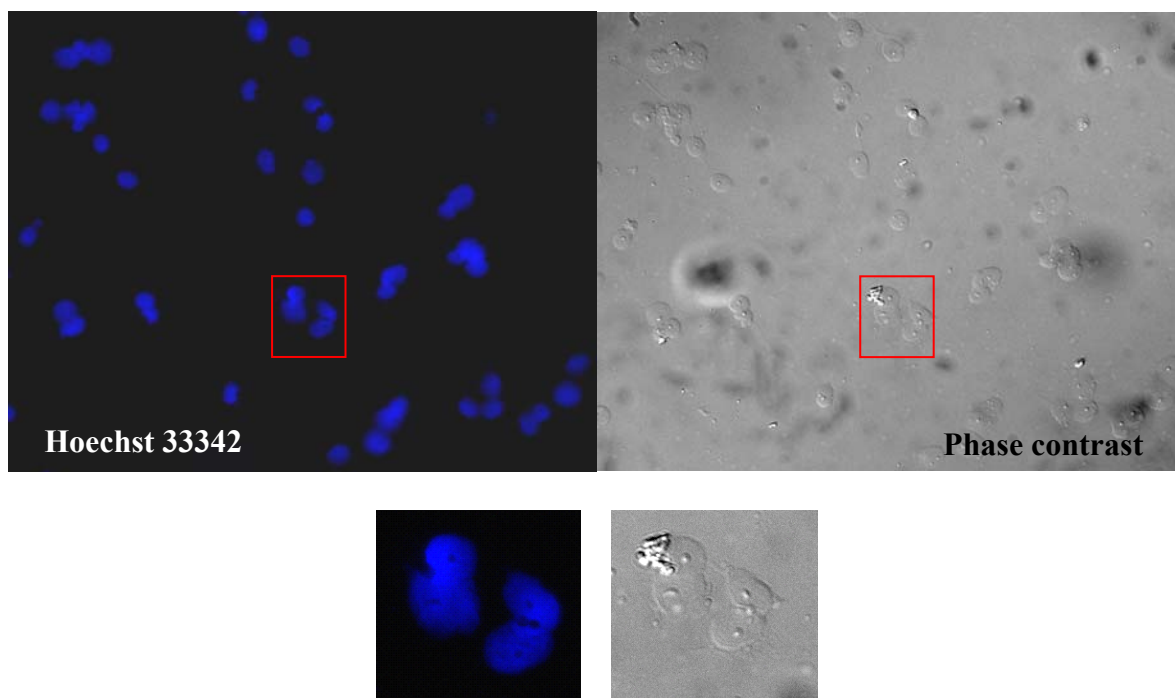
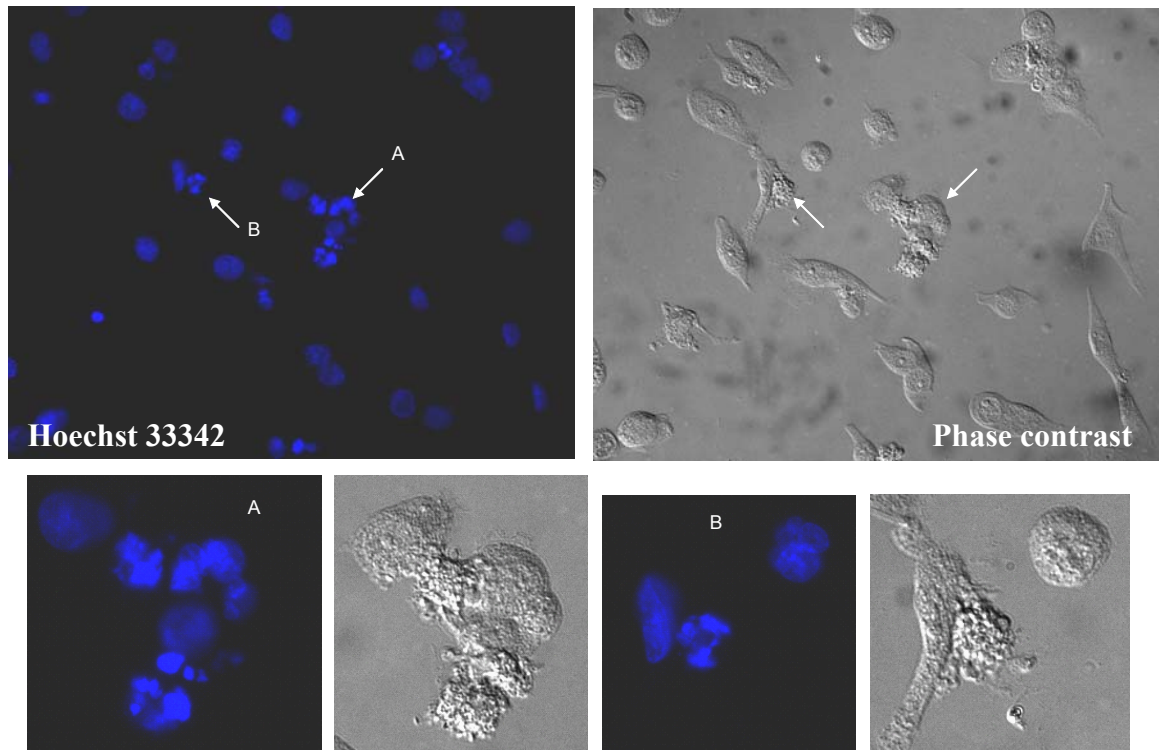

Figure 4.28. MDA-MB-231 cells treated with triton-X and stained with Hoechst 33342 after 4h of incubation. Cells were all dead. Photo courtesy of J. Balsevich.

Cisplatin presented clear features of apoptosis at 24 and 48 h incubation times with cell disruption and shrinkage as well as apoptotic bodies and blebs. The bright fluorescence in some cells corresponded to the morphological disturbances observed under a phase contrast microscope (Fig. 4.29).

a) Cisplatin treated MDA-MB-231 cells – 24h Hoechst 33342 stained



b) MDA-MB-231 Cells treated with Cisplatin – 48h

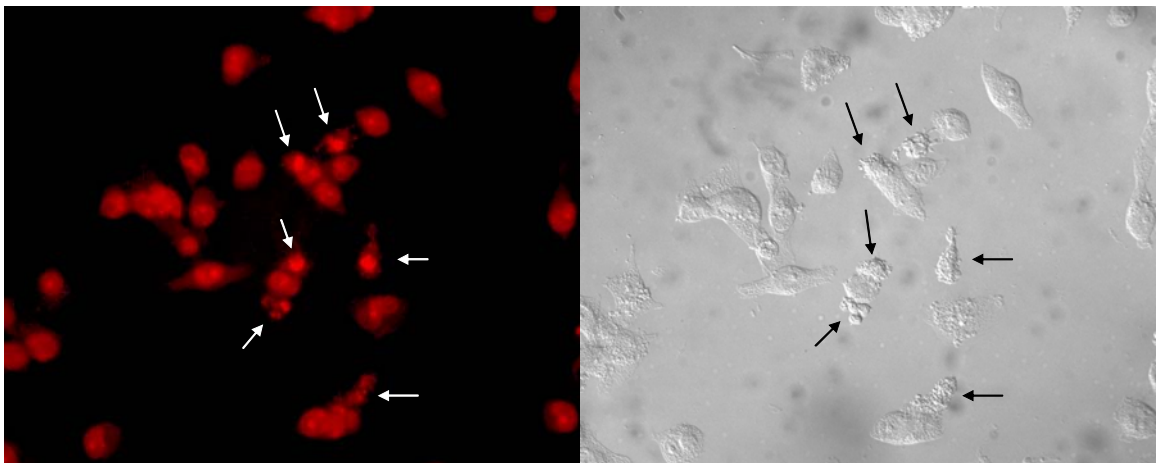

Figure 4.29. Cisplatin treated MDA-MB-231 cells stained with a) Hoechst 33342 after 24h of incubation, and b) propidium iodide after 48 h of incubation. Cells show the characteristic features of apoptosis such as nuclei condensation (brighter blue or red), blebbing and cell shrinkage. Photo courtesy of J. Balsevich.

Saponin mixture CC-19 treated cells showed apoptotic features with a remarkable reduction in cell number per plate. It was noticed that at early incubation times (4-6 h) and using very low concentrations (3 $\mu\text{g}/\text{mL}$), cells were already showing differences in morphology and size as compared with “normal” cells. Normal cells were elongated, and the stained nuclei showed uniform fluorescence. Cells undergoing apoptosis were smaller, fluorescence was accentuated in the nuclei, and fragmentation, blebs and apoptotic bodies were observed throughout. Figures 4.30 and 4.31 show the saponin-treated cells at 0, 6 and 12 h, stained with PI and Hoechst 33342, respectively. The above mentioned differences are most noticeable at higher concentrations (10 and 25 $\mu\text{g}/\text{mL}$) (Figure 4.32).

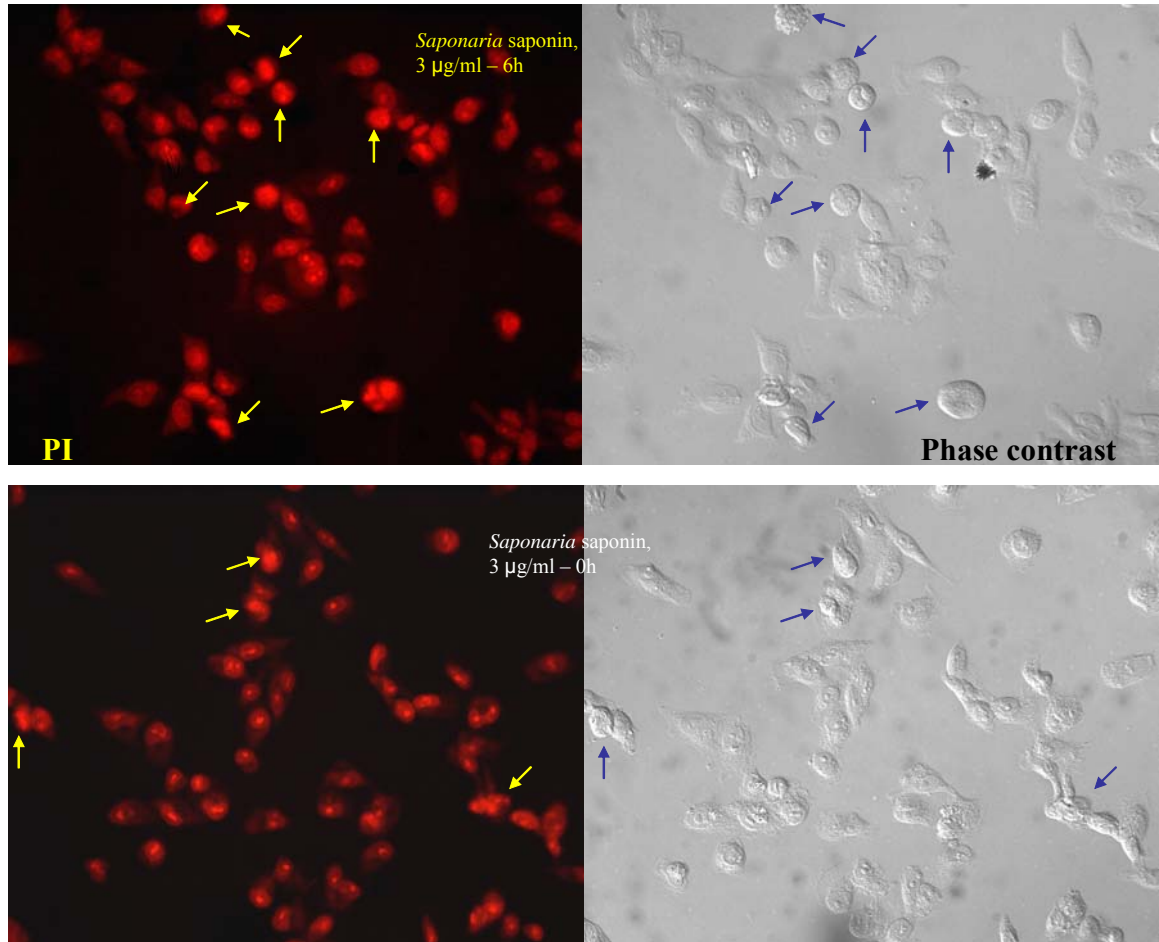

Figure 4.30. MDA-MB-231 cells treated with *Saponaria saponin* at a concentration of 3 µg/mL at 0 and 6 h of incubation and upon treatment with propidium iodide. Arrows point toward apoptotic cells. Photo courtesy of J. Balsevich.

MDA-MB-231 treated with *Saponaria* saponin – 3 $\mu\text{g/ml}$, 12h, stained with Hoechst 33342

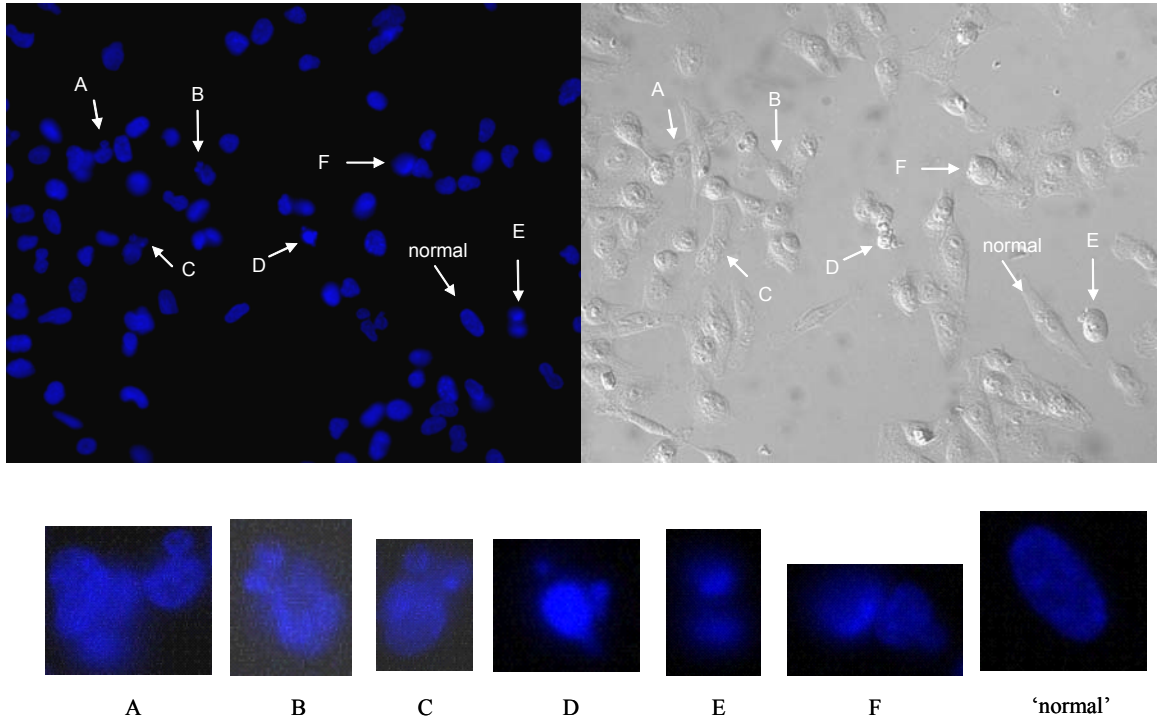

Figure 4.31. MDA-MB-231 cells treated with *Saponaria* saponin at a concentration of 3 $\mu\text{g/ml}$ after 12 h of incubation and upon treatment with Hoechst 33342. Some cells undergoing apoptosis were labeled A – F. Photo courtesy of J. Balsevich.

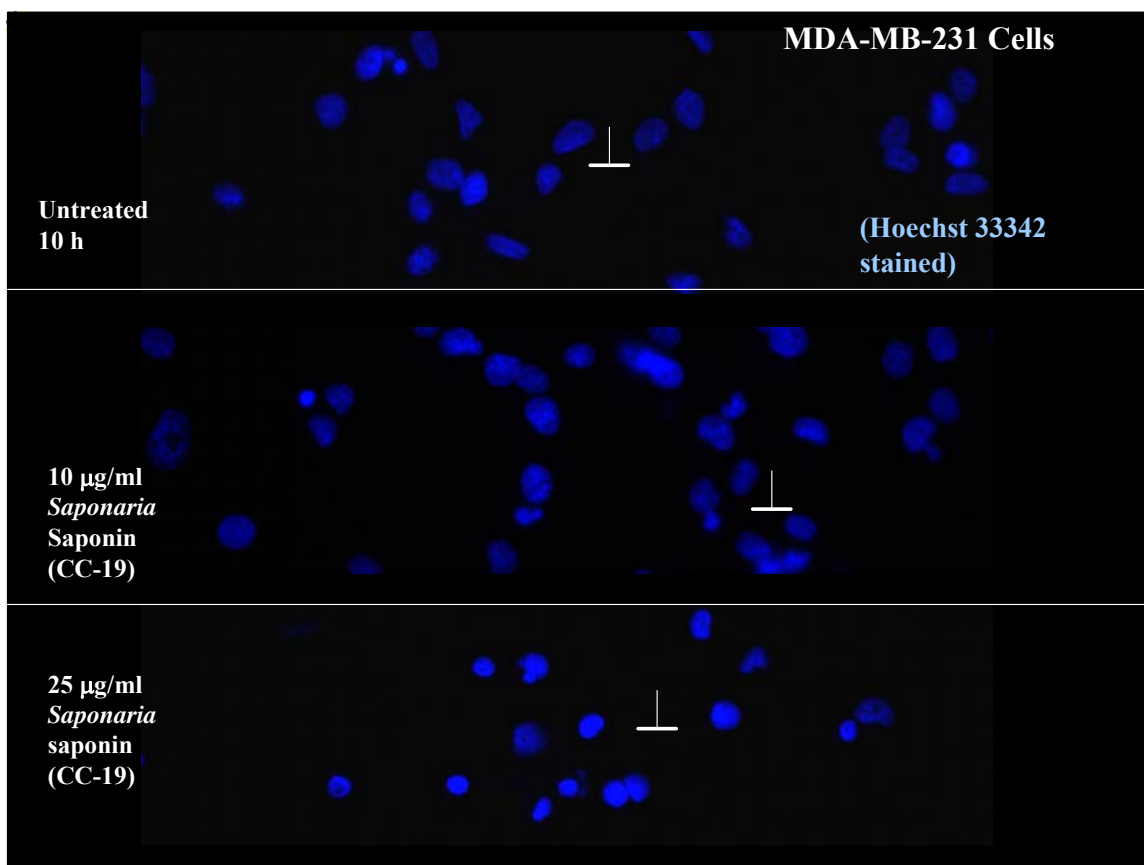

Figure 4.32. Comparison of untreated MDA-MB-231 cells after 10 h of incubation with corresponding *Saponaria* saponin treated cells at concentrations of 10 and 25 µg/mL. Photo courtesy of J. Balsevich.

Prostate cancer cells PC-3, breast cancer cells MDA-MB-231, and normal fibroblast cells CRL-2522 stained with Hoechst 33342 following a 24 hr treatment with 7 µM Segetoside H (MW 1448) showed nuclear changes characteristic of apoptotic cells (Fig. 4.33). Apoptotic nuclei have highly condensed chromatin, often in crescent shapes around the periphery of the nucleus.

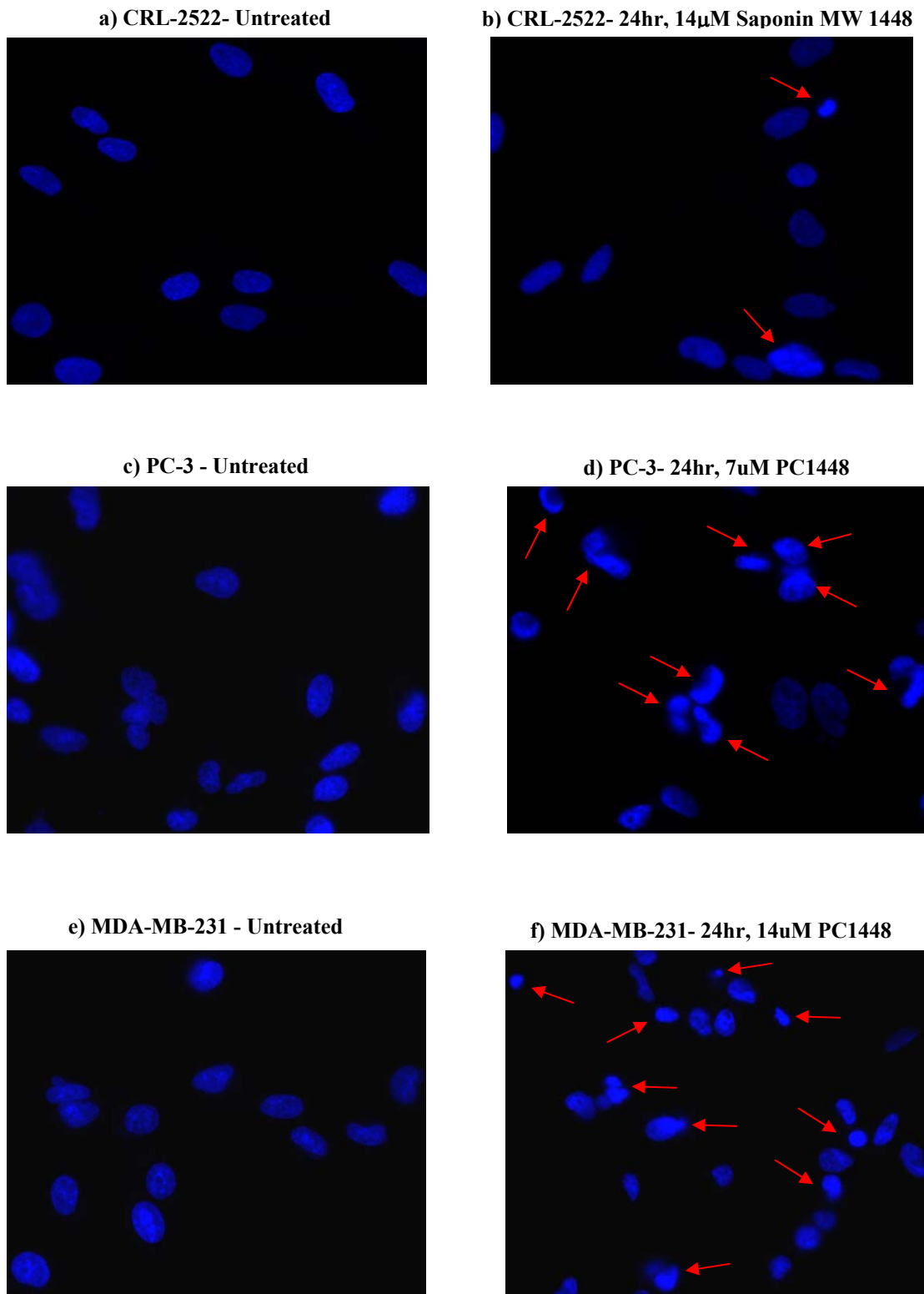

Figure 4.33. Fluorescent microscopy of Hoechst 33342 stained nuclei in untreated (a,c,e) and PC1448 treated (b,d,f) CRL-2522 (a,b), PC-3 (c,d) and MDA-MB-231 (e,f) cells. Red arrows show nuclear changes characteristic of apoptotic cells. Photo courtesy of J. Balsevich.

4.8. Stimulation of apoptosis by *Saponaria vaccaria* L. saponins

The following section describes the results from flow cytometry experiments on *Saponaria* saponins performed by Ms. Leah Deibert under the supervision of Dr. John Balsevich (NRC-PBI) and with technical assistance of Ms. Donna Dunlop (Dept. of Pharmacology, U of S). It is included in this dissertation to demonstrate current results on apoptosis as the MOA of *Saponaria* saponins as well as to exemplify some of the recent work done on *Saponaria vaccaria* L.

4.8.1. Stimulation of apoptosis in human prostate cancer cells (PC-3) by Segetoside H (MW 1448)

A time course study from 0 to 20 hrs was conducted with PC-3 cells treated with 14 μ M Segetoside H and analyzed using the Dual Sensor:MitoCaspTM. Results that demonstrate a significant increase in the cells with caspase 3/7 activity and concomitantly a dramatic increase in cells with decreased mitochondrial membrane potential are shown in Table 4.15 and Fig. 4.34 below.

In comparison to untreated PC-3 cells, there was a progressive time dependent increase representing approximately a doubling of the cells with measurable caspase 3/7 activity over the 20 hr exposure period. Additionally, there was about a 20 fold increase, (4.5 % to 94.1 %) of cells with a decreased mitochondrial membrane potential following treatment with Segetoside H. A highly significant impact was observed after just five hours exposure.

Table 4.15. Apoptosis measured in PC-3 cells treated with 14 μ M Segetoside H for 20 hrs using the Dual Sensor: MitoCaspTM Assay.

14 μM Segetoside H	Cells with caspase 3/7 activity (%)	Cells with decreased mitochondrial membrane potential (%)
Untreated	24.6	4.5
05 hr	13.0	38.0
10 hr	29.2	72.5
15 hr	42.9	89.4
20 hr	57.2	94.1

The results shown in Table 4.15 are shown graphically in Fig. 4.34. The upper left hand frame of the figure shows the condition of PC-3 cells at the beginning of the experiment. Mitochondrial membrane potential is presented on the y axis and Caspase 3/7 activity on the X axis. At time zero of the experiment the large majority of PC-3 cells showed a healthy mitochondrial membrane potential above 101 and a modest number of cell displayed Caspase 3/7 activity. After only five hours of exposure to Segetoside H there was a rapid increase in the numbers of cells with decreased mitochondrial membrane potential. Further exposure times, (frames 3-5) showed the vast majority of cells with low mitochondrial membrane potential and Capsase 3/7 activity indicating onset of apoptosis.

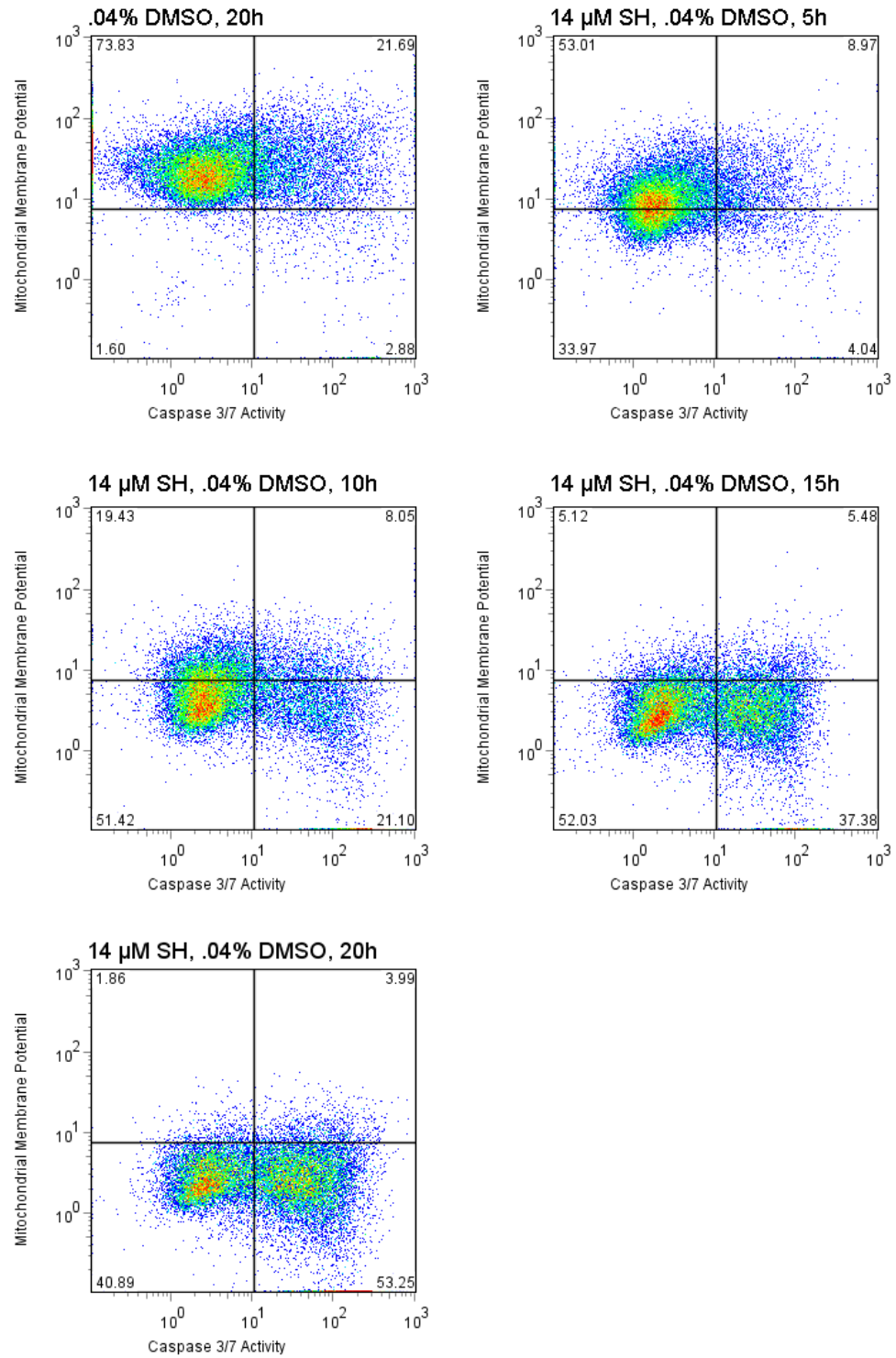

Figure 4.34. Apoptosis measured in PC-3 cells treated with 14 μM Segetoside H (MW 1448) for various times using the Dual Sensor: MitoCasp™ Assay.

A similar set of experiments was conducted to testing a range of concentrations of Segetoside H (from 7 - 17 μM). Following treatment of PC-3 cells with Segetoside H for 26 hours, a concentration dependant increase in apoptotic cells was observed (Table 4.16). The largest increase in caspase 3/7 activity was with cells treated with 10 μM Segetoside H however, all treated cells showed dramatic increases (an 8 fold increase) in caspase 3/7 activity even at 7 μM , the lowest concentration tested. The greatest change in cells with decreased mitochondrial membrane potential occurred with 14 μM Segetoside H however, again all treated cells showed large increases even at the lowest concentration tested.

Table 4.16. Apoptosis in PC-3 cells treated with various concentrations of Segetoside H for 26h measured by The Dual Sensor: MitoCaspTM Assay.

Segetoside H concentration (μM)	Cells with caspase 3/7 activity (%)	Cells with decreased mitochondrial membrane potential (%)
Untreated	10.1	2.8
7	77.8	24.8
10	86.2	30.8
14	84.0	52.0
17	77.7	41.9

The results shown in Table 4.16 are shown graphically in Fig. 4.35. As in Fig. 4.34, the upper left hand frame of the figure shows the condition of PC-3 cells at the beginning of the experiment. Mitochondrial membrane potential is presented on the y axis and Caspase 3/7 activity on the X axis. At time zero of the experiment the large majority of PC-3 cells showed a healthy mitochondrial membrane potential above 10^1 and a modest number of cell displayed Caspase 3/7 activity. After exposure of PC-3 cells to Segetoside H at all concentrations (7, 10, 14, 17 μM), there was a dramatic

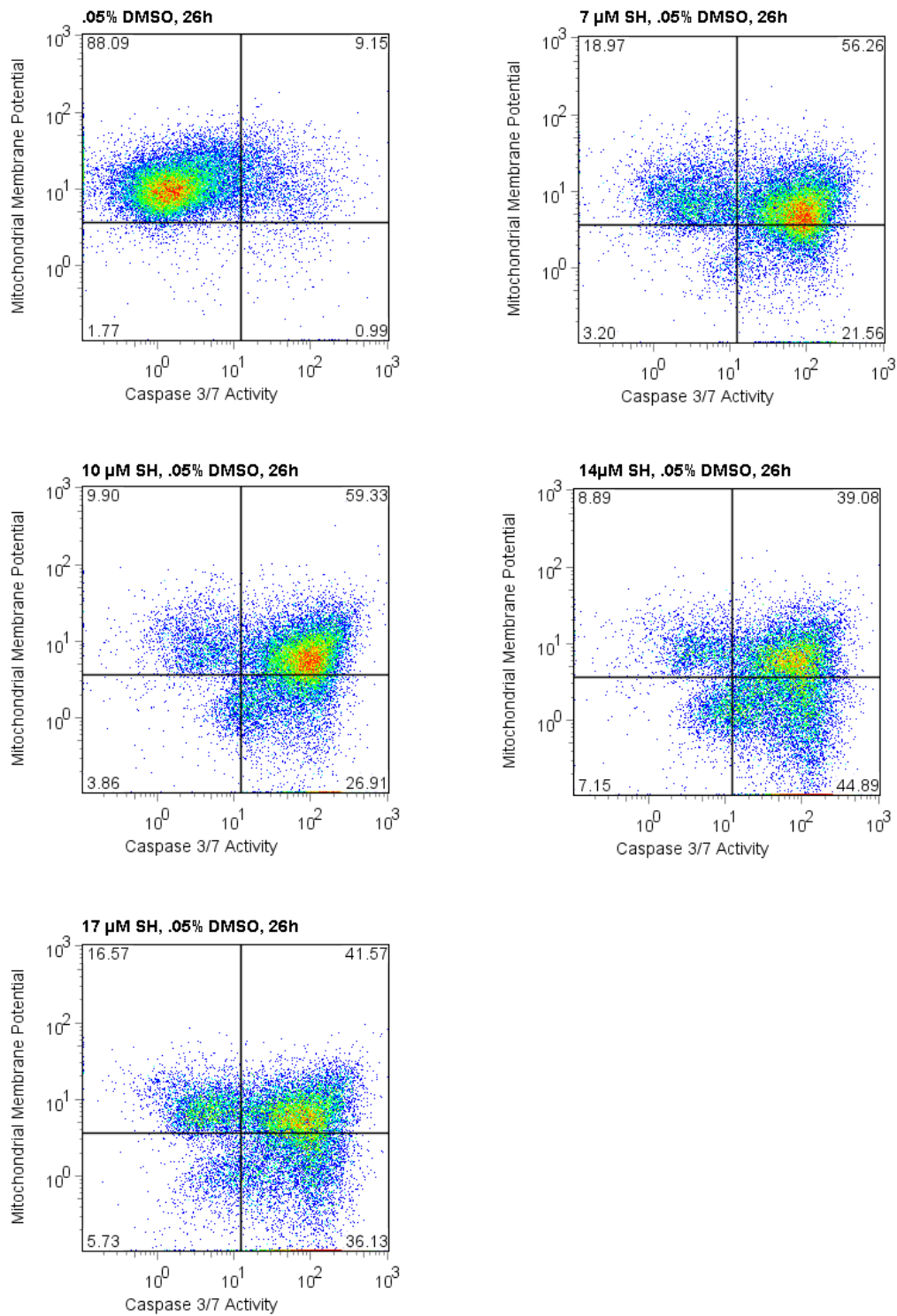

Figure 4.35. Apoptosis measured in PC-3 cells treated with various concentrations of Segetoside H for 26h using The Dual Sensor: MitoCaspTM Assay.

increase in the number of cells displaying low mitochondrial membrane potential and increased levels of caspase 3/7 indicating the induction of apoptosis. A second time course study was conducted to measure apoptosis in PC-3 cells treated with 14 μ M Segetoside H for various times. The Vybrant[®] Apoptosis Assay Kit #2 was used to assess apoptosis and results shown in Table 4.17 below demonstrate a three fold increase in Annexin V positive cells, when compared to untreated PC-3 cells, following a 24 hr treatment with Segetoside H.

Table 4.17. Apoptosis in PC-3 cells treated with 14 μ M Segetoside H for various times measured using the Vybrant[®] Apoptosis Assay Kit #2.

14 μM Segetoside H	Annexin-V positive cells (%)
Untreated	11.3
06 hr	12.4
16 hr	28.3
24 hr	34.7

Further evidence that Segetoside H stimulates apoptosis was evident from the detection of caspase 9 activity using the APO LOGIX[™] Carboxyfluorescein Caspase 9 Detection Kit.

As above, one set of experiments provided a time course study of Segetoside H over an extended 40 hr time period. Following treatment of PC-3 cells with 14 μ M Segetoside H for various times, the APO LOGIX[™] Carboxyfluorescein Caspase 9 Detection Kit was used to measure apoptosis (Table 4.18). Segetoside H treatment caused an increase in PC-3 cells with caspase 9 activity. The largest increase was seen at 20 hours again showing a three fold increase in PC-3 cells showing caspase 9 activity than in untreated cells.

Table 4.18. Apoptosis in PC-3 cells treated with 14 μ M Segetoside H for various times measured using the APO LOGIXTM Carboxyfluorescein Caspase 9 Detection Kit.

14 μM Segetoside H	Caspase 9 positive cells (%)
Untreated	8.5
10 hr	37.7
15 hr	44.2
20 hr	48.0
40 hr	29.4

These results are shown graphically in Fig. 4.36 below. The figures show the significant increase in cells expressing Caspase 9 activity in as little as a few hours after exposure to Segetoside H.

A final concentration range experiment was conducted with PC-3 cells treated with Segetoside H for 20 hours at concentrations ranging from 7–17 μ M (Table 4.19). The number of cells with caspase 9 activity increased with Segetoside H concentration up to 14 μ M, at which the cells showed a four fold increase compared to untreated PC-3 cells. As shown above all treated cells regardless of Segetoside H concentration showed large increases in caspase 9 activity.

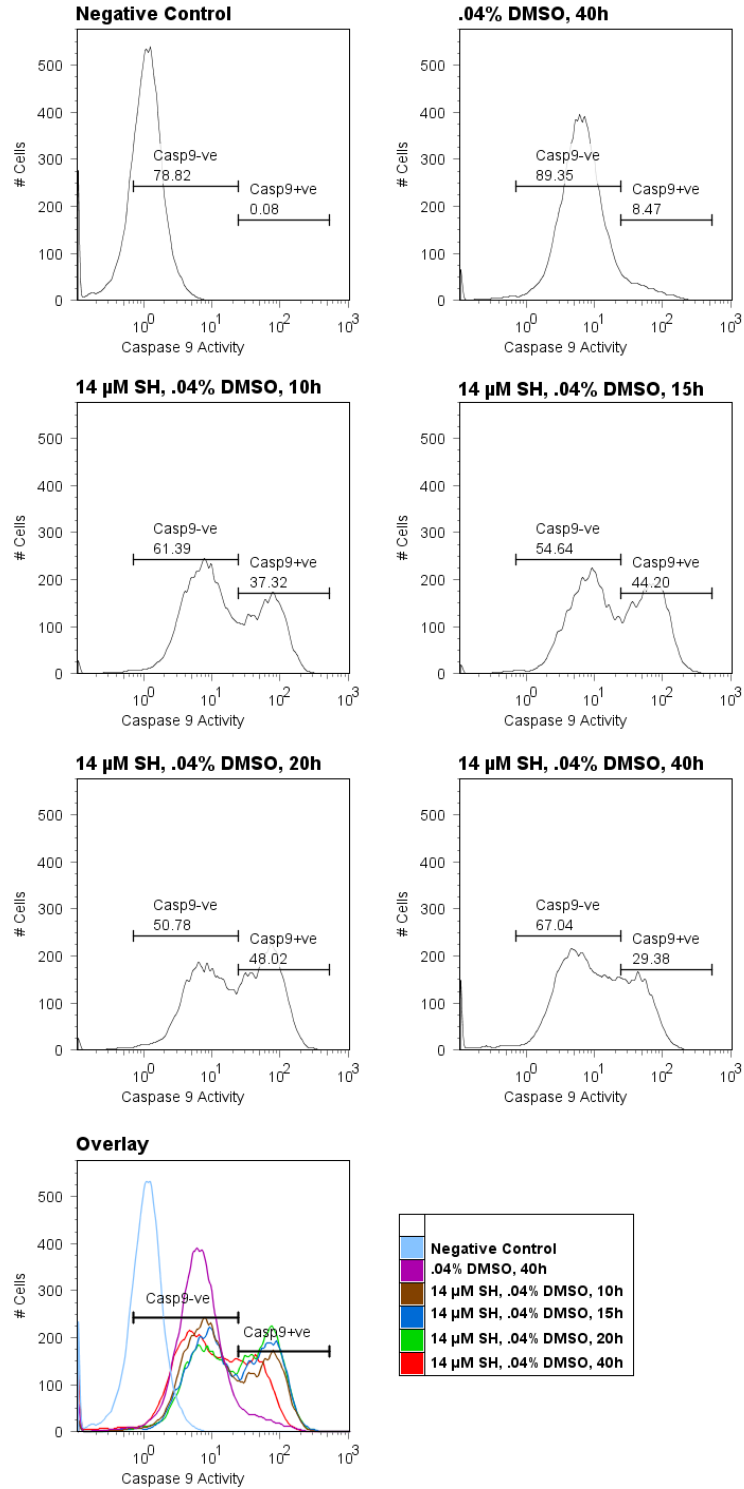

Figure 4.36. Apoptosis measured in PC-3 cells treated with 14 μ M Segetoside H for various times using the APO LOGIXTM Carboxyfluorescein Caspase 9 Detection Kit.

Table 4.19. Apoptosis in PC-3 cells treated with various concentrations of Segetoside H for 20 hr measured using the APO LOGIX™ Carboxyfluorescein Caspase 9 Detection Kit.

Segetoside H concentration (μM)	Caspase 9 positive cells (%)
Untreated	13.2
7	47.7
10	73.9
14	75.3
17	65.6

These results are shown graphically in Fig. 4.37 below. The figures show the significant increase in cells expressing caspase 9 activity with all concentrations of Segetoside H treatments. The optimal concentration appears to be in the 10–15 μM range.

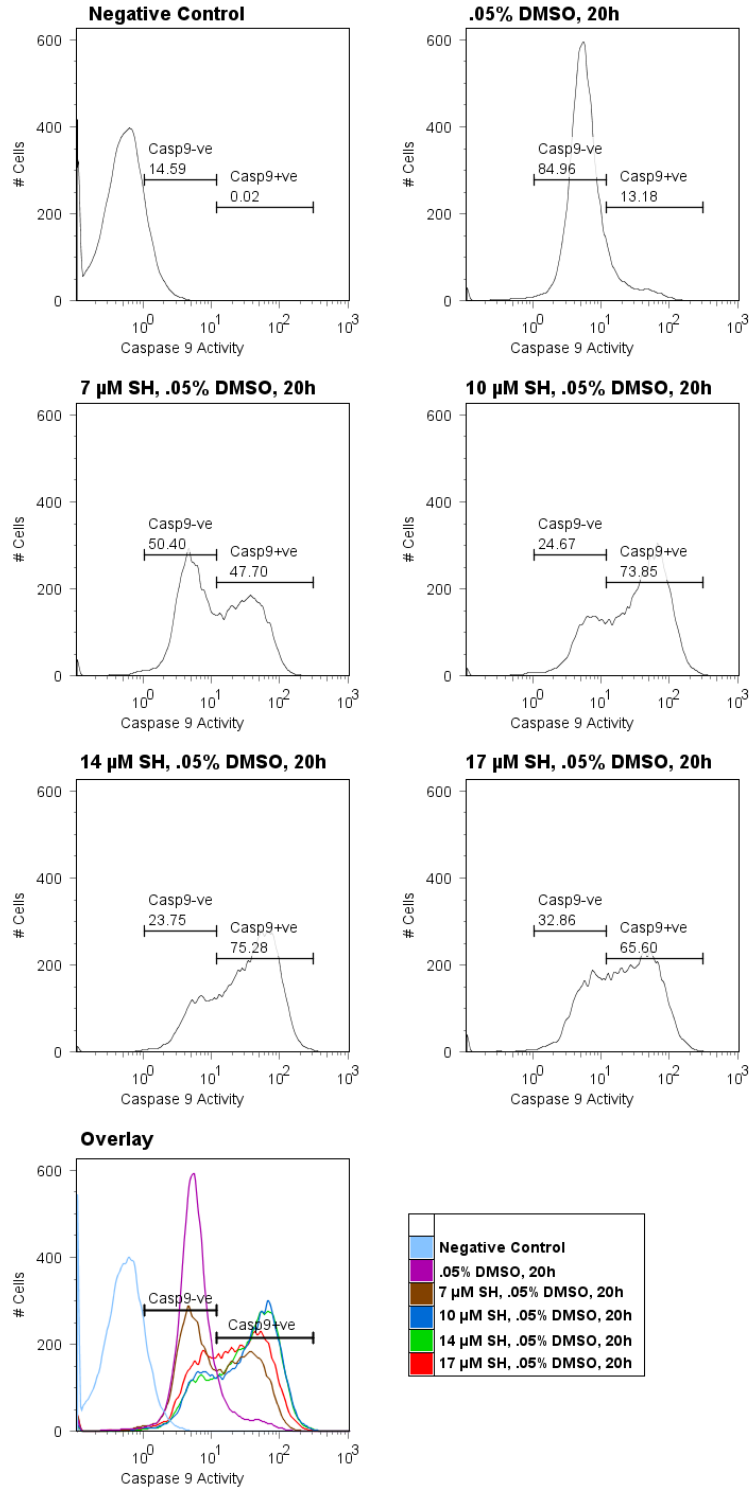

Figure 4.37. Apoptosis measured in PC-3 cells following a 20 hr treatment with various concentrations of Segetoside H using the APO LOGIX™ Carboxyfluorescein Caspase 9 Detection Kit.

4.8.2. Stimulation of apoptosis in human breast cancer cells (MDA-MB-231) by Segetoside H (MW 1448)

MDA-MB-231 cells were treated with Segetoside H and assayed for apoptosis as previously described for PC-3 cells.

Following treatment with 14 μ M Segetoside H for various times, MDA-MB-231 cells were assessed for apoptotic activity using the Vybrant[®] Apoptosis Assay Kit #2. The results are shown in Table 4.20 and Fig. 4.38. A 2.7 fold increase in Annexin V positive cells, compared to untreated cells was seen after just 12 hr exposure to Segetoside H. These results are shown graphically in Fig 4.38. A shift in cell position in the diagram to the right and upwards indicates Annexin-V binding to phosphoserine residues external to the plasmalemma. The externalization of phosphoserine only occurs when cells have entered apoptosis.

Table 4.20. Apoptosis in MDA-MB-231 cells treated with 14 μ M Segetoside H for various times measured using the Vybrant[®] Apoptosis Assay Kit #2.

14 μ M Segetoside H	Annexin-V positive cells (%)
Untreated	17.1
12 hr	46.3
24 hr	37.9
48 hr	37.9

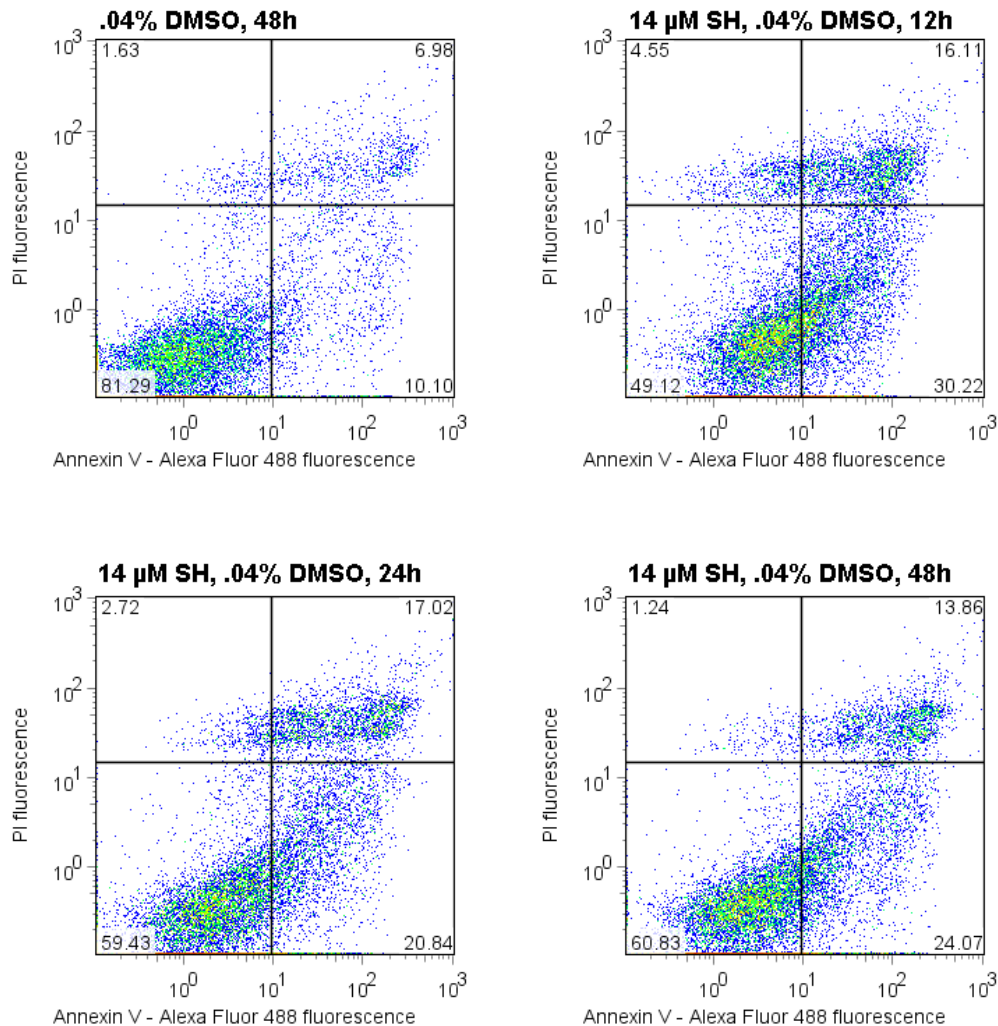

Figure 4.38. Apoptosis in MDA-MB-231 cells treated with 14 μM Segetoside H for various times measured using the Vybrant[®] Apoptosis Assay Kit #2.

Additionally, MDA-MB-231 cells treated with 14 μM Segetoside H for various times were analyzed for apoptotic activity using the APO LOGIX[™] Carboxyfluorescein Caspase 9 Detection Kit. Results are shown below in Table 4.21. Cells treated with Segetoside H showed an increased number with caspase 9 activity compared to untreated cells, in as little as 10 hrs. The maximum effect was a 2.5 fold increase in cells with caspase 9 activity after a 40 hr exposure to Segetoside H. These results shown

graphically in Fig 4.39 below again show the rapid rise in caspase 9 activity after cells are exposed to Segetoside H indicating cells are undergoing apoptosis.

Table 4.21. Apoptosis in MDA-MB-231 cells treated with 14 μ M Segetoside H for various times measured using the APO LOGIXTM Carboxyfluorescein Caspase 9 Detection Kit.

14 μM Segetoside H	Caspase 9 positive cells (%)
Untreated	16.6
10 hr	25.0
15 hr	31.6
20 hr	32.5
40 hr	41.6

Results are shown graphically in Fig. 4.39 below. The increase in numbers of the Caspase positive cells can be easily seen within ten hours exposure to Segetoside H.

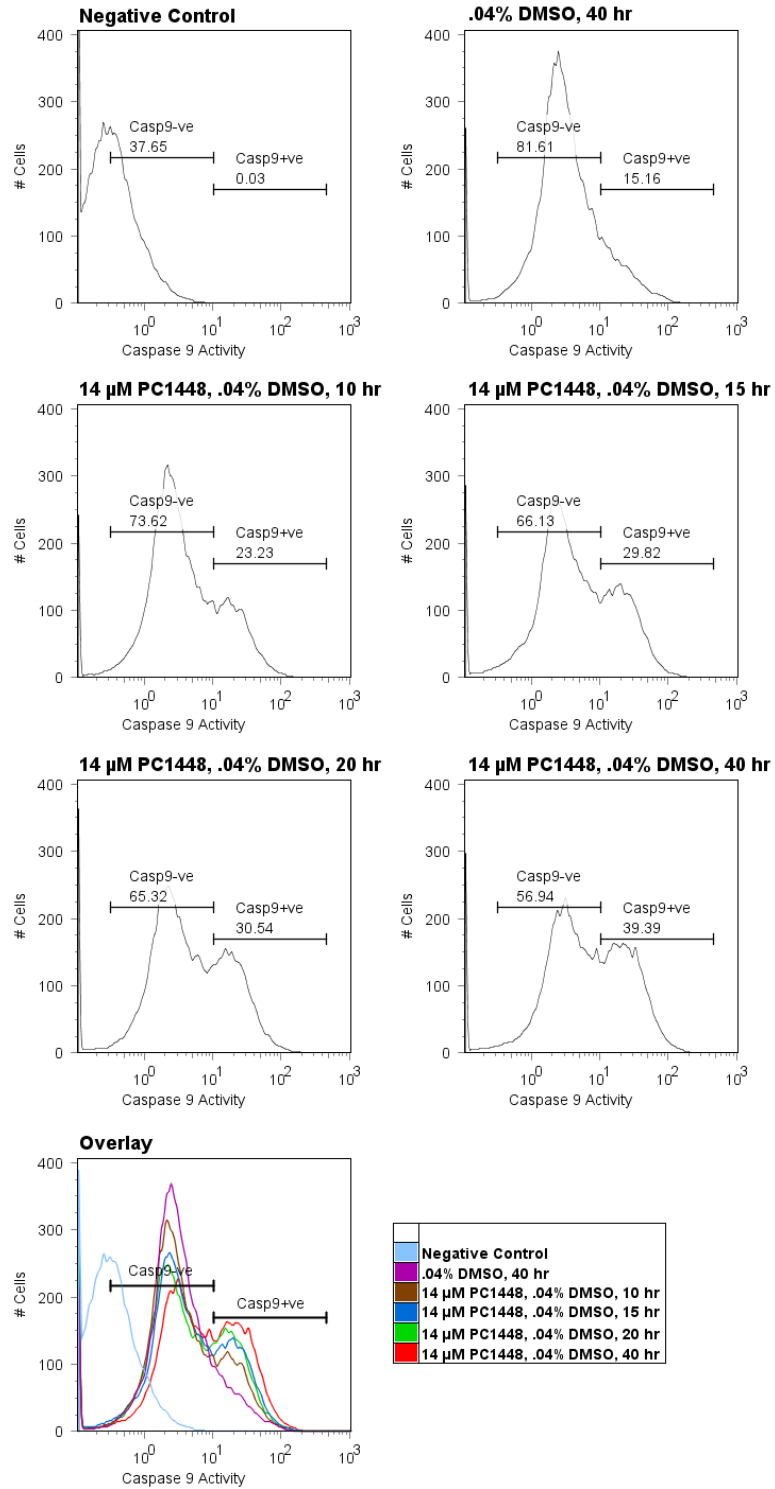

Figure 4.39. Apoptosis in MDA-MB-231 cells treated with 14 μM Segetoside H for various times measured using the APO LOGIX™ Carboxyfluorescein Caspase 9 Detection Kit.

4.8.3. Failure of Segetoside H (MW 1448) to stimulate apoptosis in human fibroblast normal cells (CRL-2522)

CRL-2522 cells were treated with Segetoside H and assayed for apoptosis as described above for PC-3 cells.

CRL-2522 cells were treated with 14 μ M Segetoside H for various times and analyzed using the Dual Sensor:MitoCaspTM Assay. Results are shown in Table 4.22. and diagrammatically in Fig. 4.40 below.

Exposure of CRL-2522 cells to Segetoside H, even over prolonged times, showed no increase in cells with lowered mitochondrial membrane potential. Additionally, there was no evidence of the increase in Caspase 3/7 activity until the time in culture is extended and cultures are aging. These observations support the view that Segetoside H at 14 μ M concentration had no significant effect on apoptosis in normal fibroblast cells.

Table 4.22. Apoptosis in human fibroblast normal cells (CRL-2522) cells treated with 14 μ M Segetoside H for various times measured using the Dual Sensor: MitoCaspTM Assay.

14 μ M Segetoside H	Cells with caspase 3/7 activity (%)	Cells with decreased mitochondrial membrane potential (%)
Untreated	3.1	1.9
10 hr	3.7	1.4
20 hr	5.5	1.4
30 hr	32.8	0.8

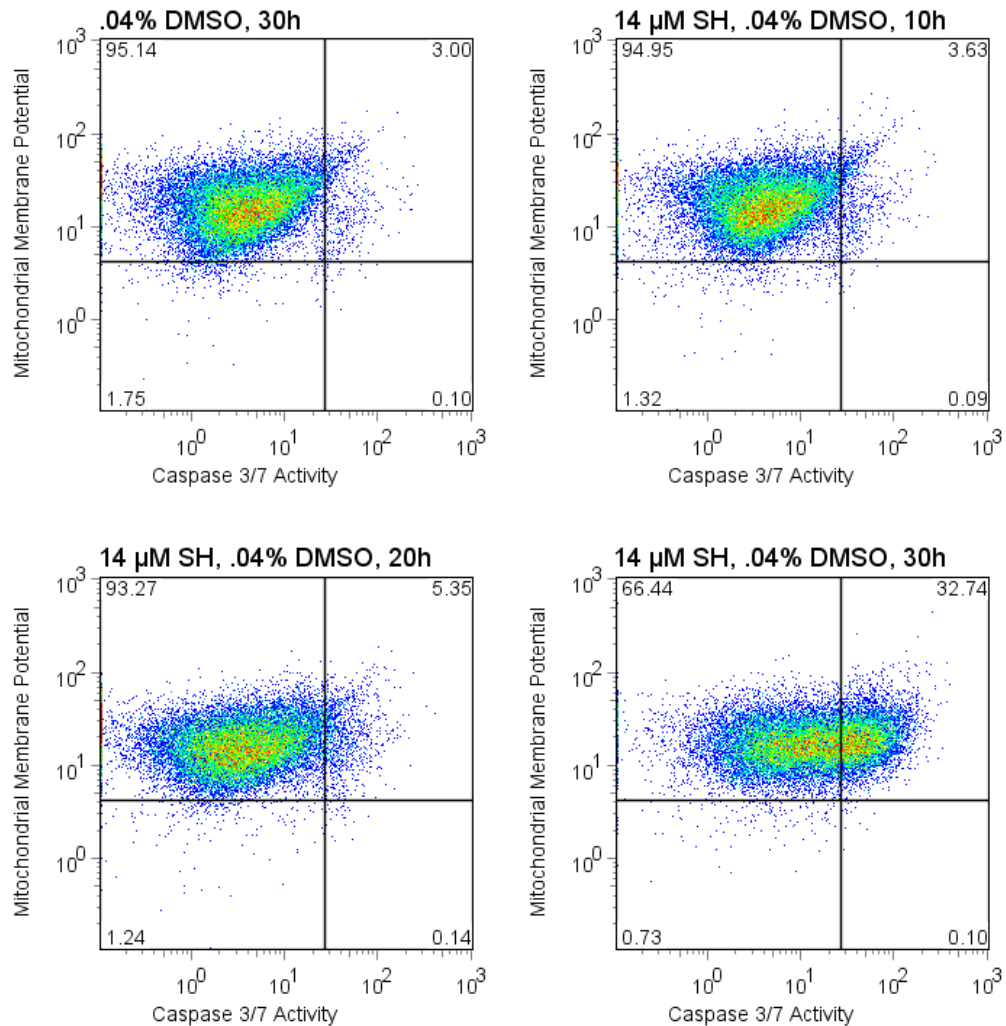

Figure 4.40. Apoptosis in human fibroblast normal cells (CRL-2522) treated with 14 μM Segetoside H for various times measured using the Dual Sensor: MitoCaspTM Assay.

These results shown graphically in Fig. 4.40 demonstrate that Segetoside H neither resulted in an increase in cells with reduced mitochondrial membrane potential nor an increase in cells expressing caspase 3/7 activity until the cultures were advanced in age.

This result was confirmed by the Vybrant[®] Apoptosis Assay . CRL-2522 cells were treated with 14 μ M Segetoside H for various times, the Vybrant[®] Apoptosis Assay Kit #2 was used to measure apoptosis as shown in Table 4.23 and Fig. 4.41 below. No meaningful changes in the number of CRL-2522 cells showing Annexin V staining following Segetoside H treatment were evident.

Table 4.23. Apoptosis in human fibroblast normal cells (CRL-2522) treated with 14 μ M Segetoside H for various times measured using the Vybrant[®] Apoptosis Assay Kit #2.

14 μM Segetoside H	Annexin-V positive cells (%)
Untreated	13.5
10 hr	17.2
20 hr	9.3
40 hr	18.2

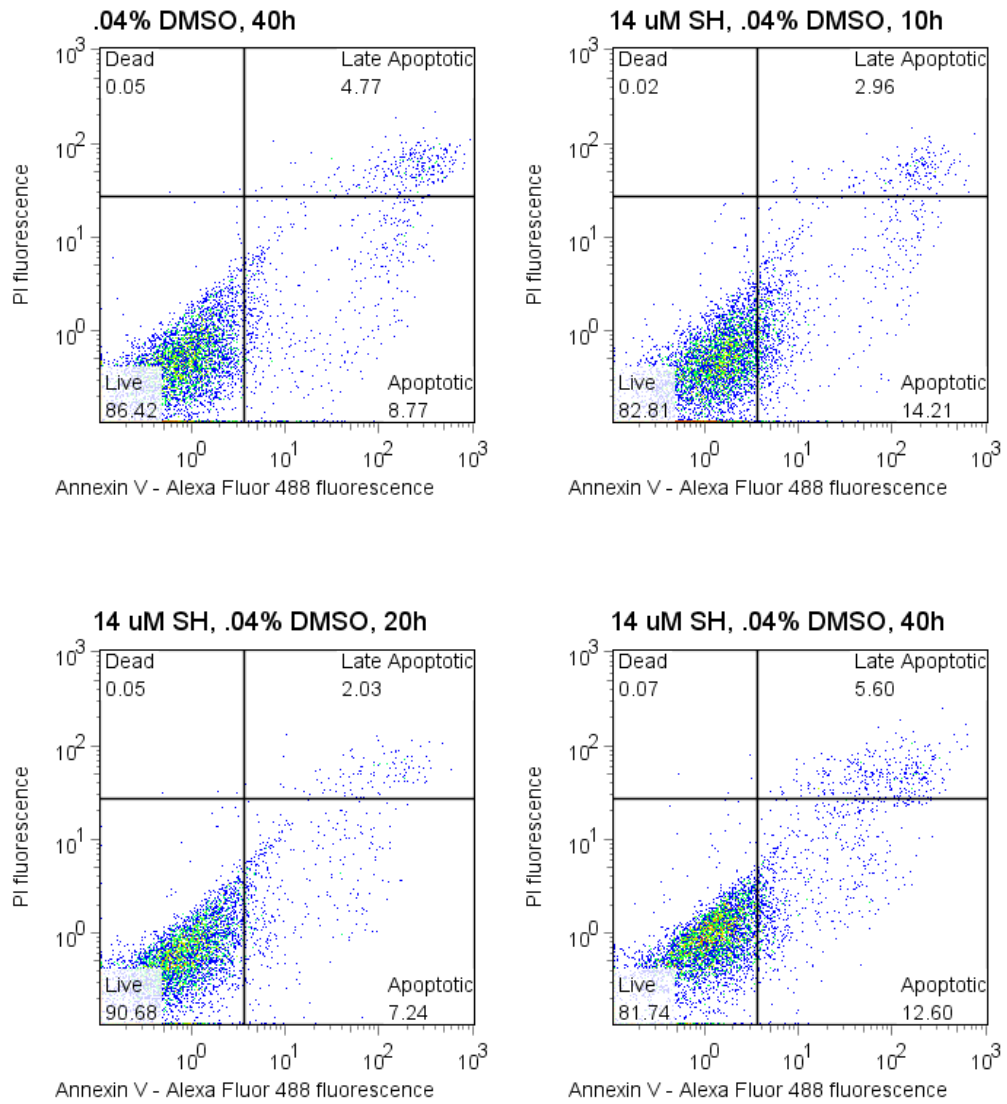

Figure 4.41. Apoptosis in CRL-2522 cells treated with 14 μM Segetoside H for various times measured using the Vybrant® Apoptosis Assay Kit #2.

A still further indication that Segetoside H does not stimulate apoptosis in normal fibroblast CRL-2522 cells was obtained using the APO LOGIX™ Carboxyfluorescein caspase 9 Detection Kit. Results from treatment of CRL-2522 cells with 14 μ M Segetoside H for various times are shown in Table 4.24 and Fig. 4.42 below. No increase in Caspase 9 positive cells was observed following a 10 to 40 hr treatment with Segetoside H.

Table 4.24. Apoptosis in CRL-2522 cells treated with 14 μ M Segetoside H for various times measured using the APO LOGIX™ Carboxyfluorescein Caspase 9 Detection Kit.

14 μM Segetoside H	Caspase 9 positive cells (%)
Untreated	8.9
10 hr	15.9
20 hr	10.6
40 hr	9.5

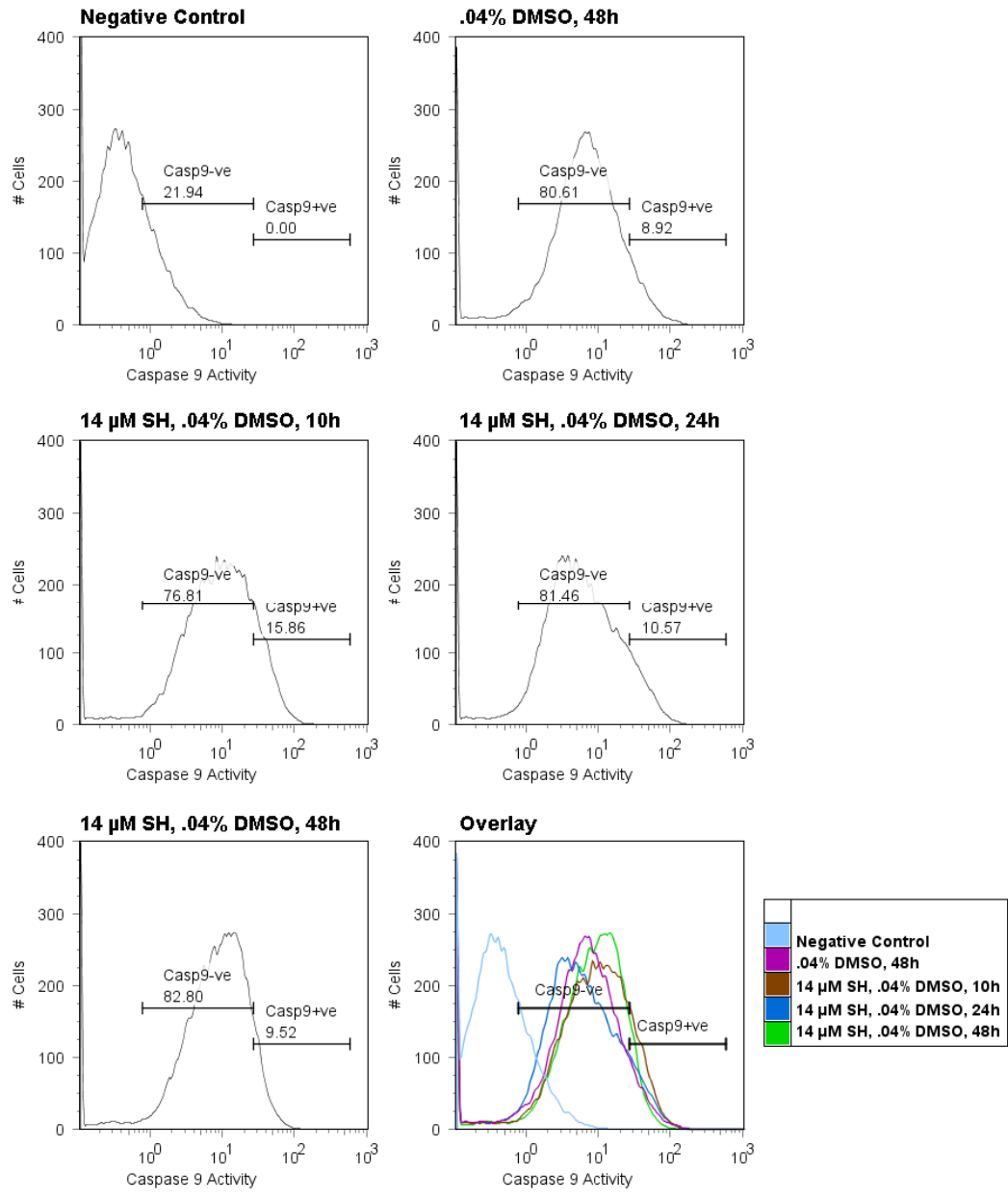

Figure 4.42. Apoptosis in human fibroblast normal cells (CRL-2522) treated with 14 μM Segetoside H for various times measured using the APO LOGIX™ Carboxyfluorescein Caspase 9 Detection Kit.

4.8.4. Stimulation of apoptosis in human prostate cancer cells (PC-3) by Segetoside I (MW 1464)

The ability of Segetoside I to induce apoptosis in PC-3 cells was tested using apoptosis assays described above. PC-3 cells were treated with Segetoside I using methods described for PC1448.

PC-3 cells treated with 7 μ M Segetoside I for various times were analyzed using the Dual Sensor: MitoCaspTM Assay. Results are shown in Table 4.25 and Fig. 4.43 below. Exposure to Segetoside I at a concentration of 7 μ M induced apoptosis in PC-3 cells in a time dependent fashion. Increases in apoptotic activity were apparent after only 10 hrs and increased dramatically thereafter. After exposure of PC-3 cells to 7 μ M Segetoside I for 30 hr, the number of cells with caspase 3/7 activity increased four fold whereas cells with decreased mitochondrial membrane potential increased more than ten fold.

Table 4.25. Apoptosis in human prostate cancer cells (PC-3) treated with 7 μ M Segetoside I for various times measured using the Dual Sensor: MitoCaspTM Assay.

7 μ M Segetoside I	Cells with caspase 3/7 activity (%)	Cells with decreased mitochondrial membrane potential (%)
Untreated	9.0	1.8
10 hr	12.2	5.1
20 hr	40.1	21.4
30 hr	54.6	51.2

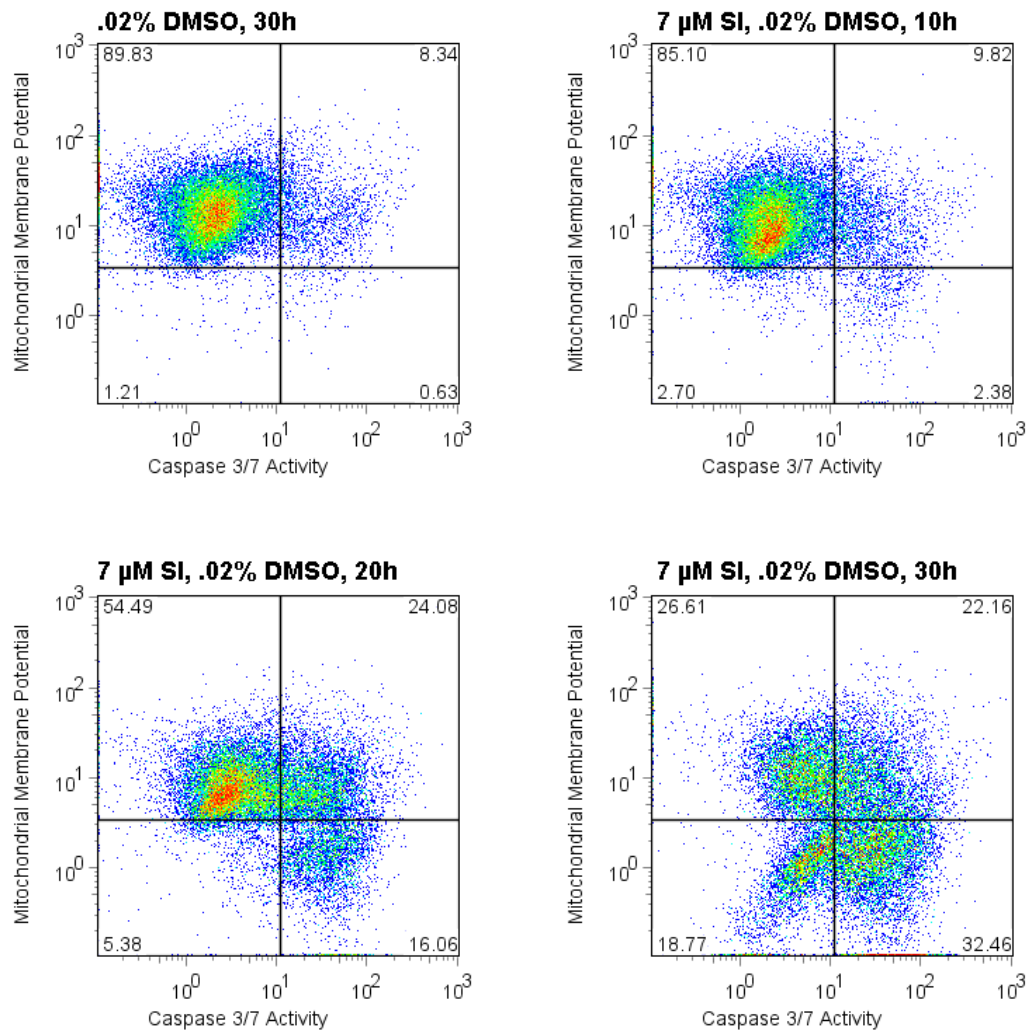

Figure 4.43. Apoptosis in human prostate cancer cells (PC-3) treated with 7 μM Segetoside I for various times measured using the Dual Sensor: MitoCaspTM Assay.

This strong induction of apoptosis by Segetoside I at a concentration of 7 μM suggested that lower concentrations may also be effective. A series of decreasing concentrations of Segetoside I (1.75-7 μM) were tested for 26 hr using the Dual Sensor: MitoCaspTM Assay, shown in Table 4.26 and Fig. 4.44 below. The results show clearly the induction of apoptosis with all concentrations tested, but with significant effect at concentrations of 3.5 μM or higher.

Table 4.26. Apoptosis in human prostate cancer cells (PC-3) treated with various concentrations of Segetoside I for 26 hr measured using the Dual Sensor: MitoCaspTM Assay.

Segetoside I concentration (μM)	Cells with caspase 3/7 activity (%)	Cells with decreased mitochondrial membrane potential (%)
Untreated	7.8	1.7
1.75	8.5	3.2
3.50	40.4	14.8
5.25	49.5	20.3
7.00	59.4	24.1

These results are shown graphically in Fig 4.44 below. An increase in Caspase 3/7 activity and an increase in the number of cells with reduced mitochondrial membrane potential are shown in a dose dependent fashion. A concentration of only 3.5 μM Segetoside I was capable of significant induction of apoptosis.

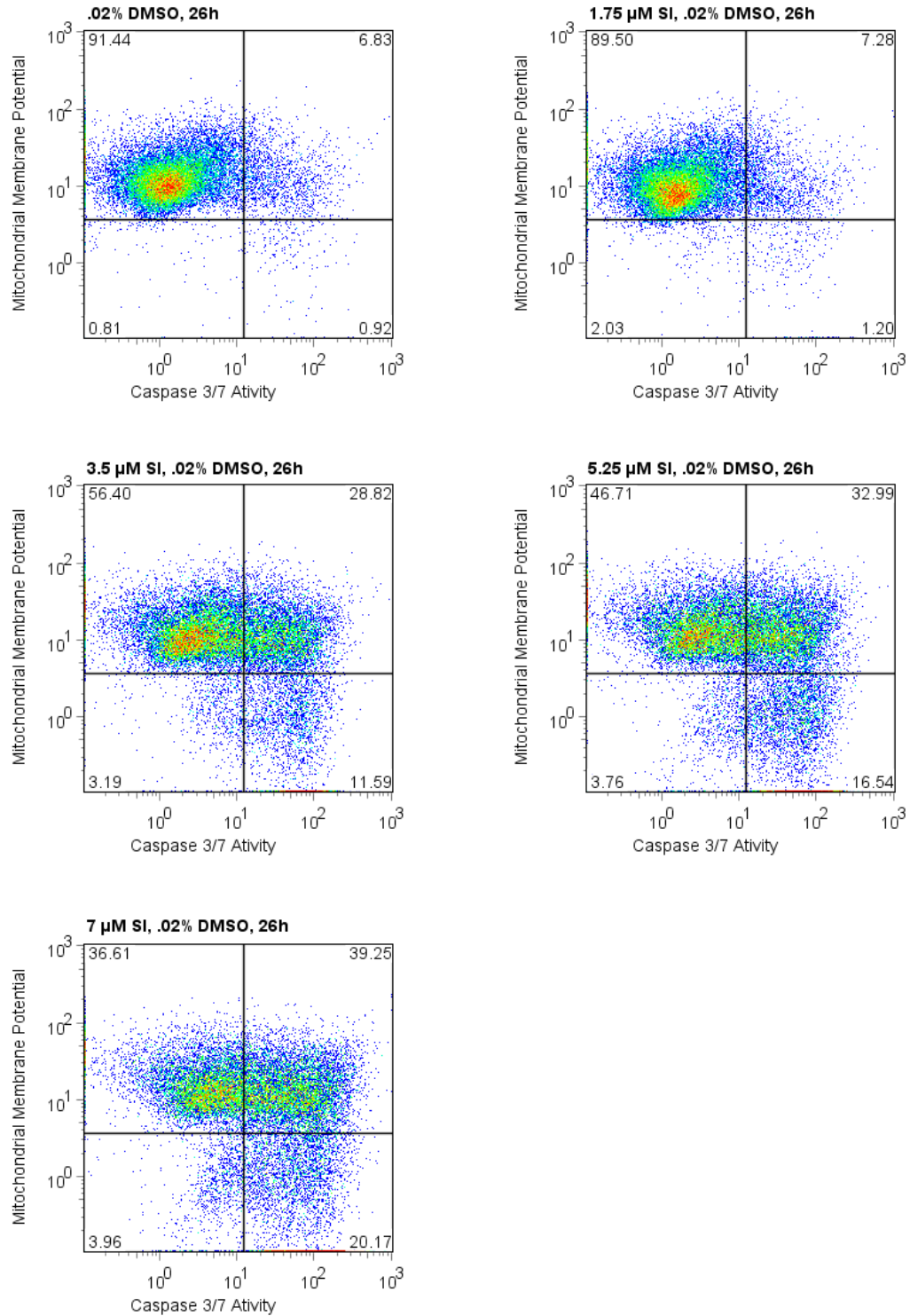

Figure 4.44. Apoptosis in human prostate cancer cells (PC-3) treated with various concentrations of Segetoside I for 26h measured using the Dual Sensor: MitoCaspTM Assay.

These results were confirmed by the Vybrant[®] Apoptosis Assay Kit #2 used to measure apoptosis in PC-3 cells treated with 7 μ M or 14 μ M Segetoside I for various times as shown in Table 4.27 and 4.28 and Fig 4.45 below. PC-3 cells showed a three to six fold increase in Annexin V positive cells, when compared to untreated PC-3 cells, following a 30 hr treatment with Segetoside I.

Table 4.27. Apoptosis measured in human prostate cancer cells (PC-3) treated with 7 μ M Segetoside I for various times measured using the Vybrant[®] Apoptosis Assay Kit #2.

7 μM Segetoside I	Annexin-V positive cells (%)
Untreated	12.4
12 hr	15.0
24 hr	28.5
36 hr	38.0

Table 4.28. Apoptosis measured in human prostate cancer cells (PC-3) treated with 14 μ M Segetoside I for various times measured using the Vybrant[®] Apoptosis Assay Kit #2.

14 μM Segetoside I	Annexin-V positive cells (%)
Untreated	8.5
10 hr	11.5
20 hr	28.9
40 hr	49.4

These results are shown graphically in Fig. 4.45 below.

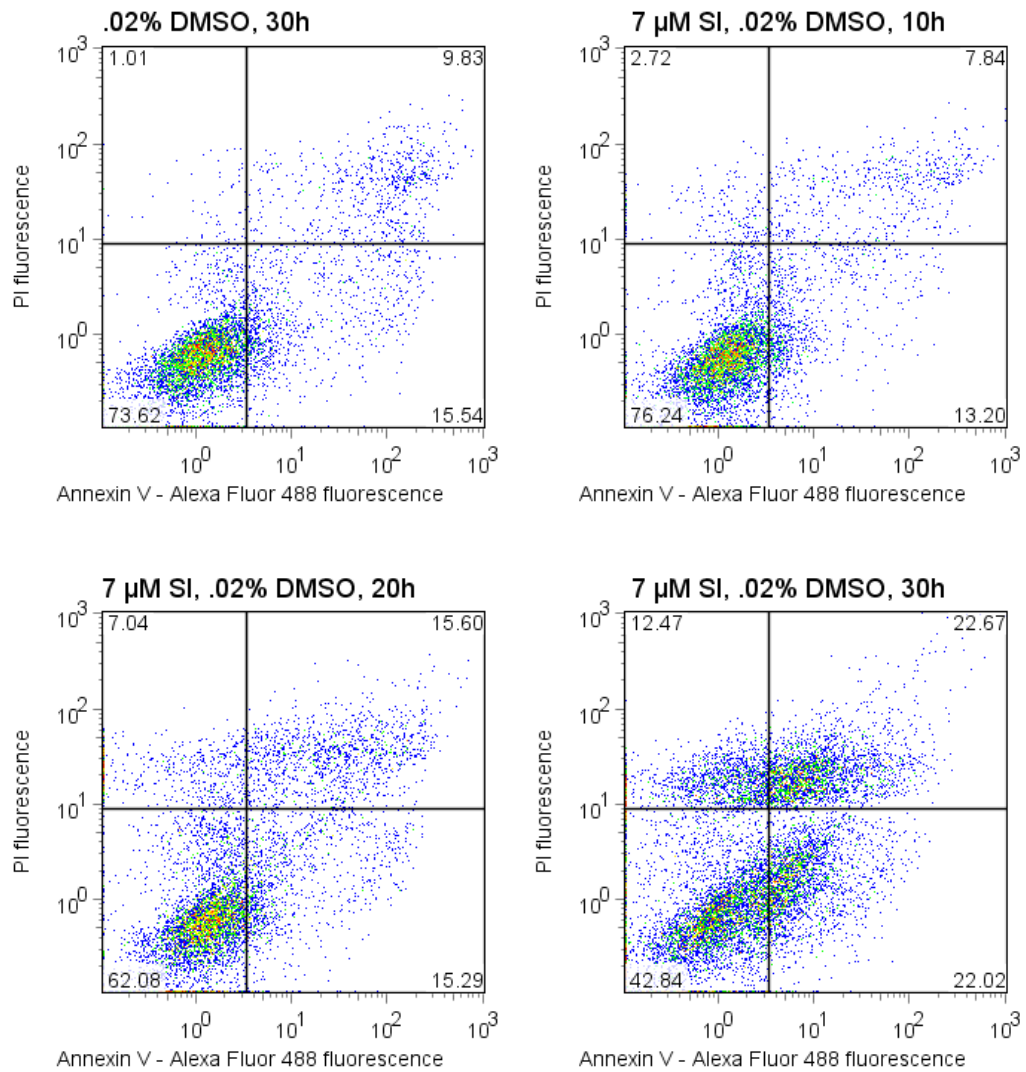

Figure 4.45. Apoptosis in human prostate cancer cells (PC-3) treated with 7 μ M Segetoside I for various times measured using the Vybrant[®] Apoptosis Assay Kit #2.

4.8.5. Stimulation of apoptosis in human breast cancer cells (MDA-MB-231) by Segetoside I (MW 1464)

MDA-MB-231 breast cancer cells were treated with Segetoside I as previously described for Segetoside H. Apoptosis assays were performed as described above.

Following treatment of MDA-MB-231 cells with 3.5 μ M Segetoside I for various times, the Dual Sensor: MitoCaspTM Assay was used to measure apoptosis as shown in Table 4.29 and Fig 4.46 below. Segetoside I was able to induce apoptosis in MDA-MB-231 cells at a concentration of 3.5 μ M within ten hours. After exposure of PC-3 cells to 3.5 μ M Segetoside I for 30 hr, the number of cells with caspase 3/7 activity increased by two fold, whereas the number of cells with reduced mitochondrial membrane potential increased eight fold.

Table 4.29. Apoptosis measured in human breast cancer cells (MDA-MB-231) treated with 3.5 μ M Segetoside I for various times using the Dual Sensor: MitoCaspTM Assay.

3.5 μM Segetoside I	Cells with caspase 3/7 activity (%)	Cells with decreased mitochondrial membrane potential (%)
Untreated	15.0	6.6
10 hr	20.0	19.9
20 hr	27.5	51.5
30 hr	29.1	52.0

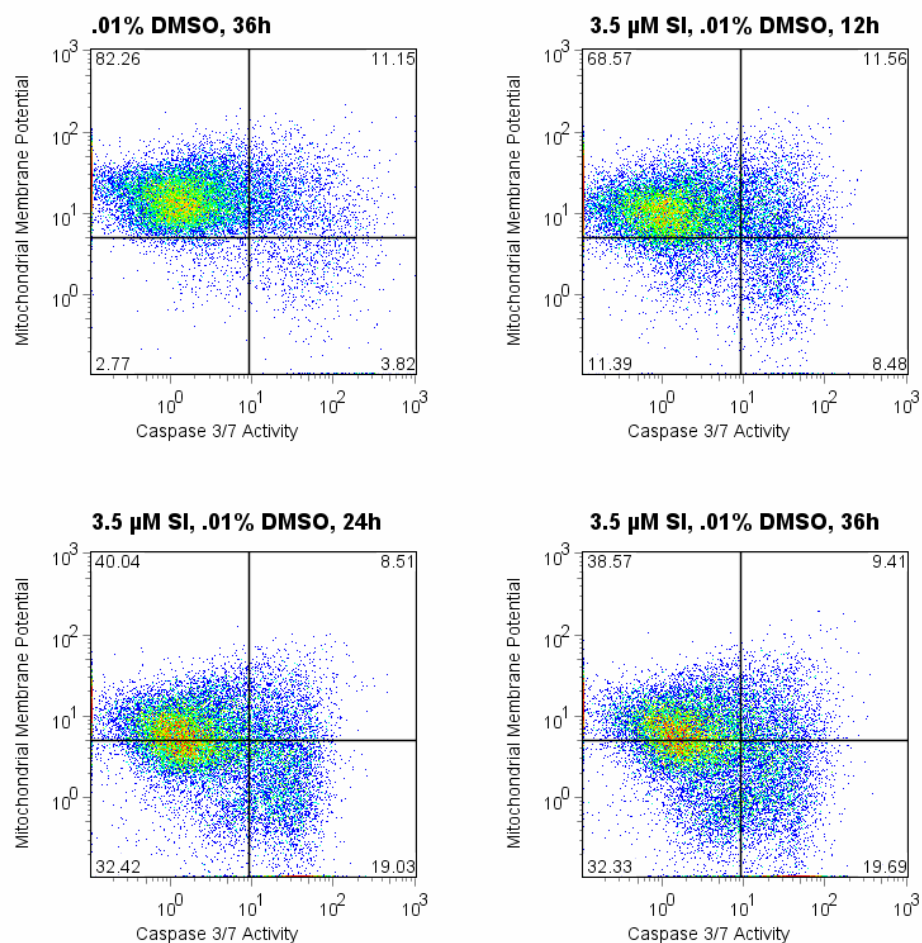

Figure 4.46. Apoptosis in human breast cancer cells (MDA-MB-231) treated with 3.5 μM Segetoside I for various times measured using the Dual Sensor:MitoCaspTM Assay.

These results were confirmed by treatment of MDA-MB-231 cells with 7 μ M Segetoside I for various times using the Vybrant[®] Apoptosis Assay Kit #2. Results are shown in Table 4.30 and Fig. 4.47 below. After a 36 hr exposure to Segetoside I, there was a 2-3 fold increase in Annexin V positive cells compared to untreated cells.

Table 4.30. Apoptosis in human breast cancer cells (MDA-MB-231) treated with 7 μ M Segetoside I for various times measured using the Vybrant[®] Apoptosis Assay Kit #2.

7 μM Segetoside I	Annexin-V positive cells (%)
Untreated	17.2
12 hr	28.8
24 hr	39.7
36 hr	49.3

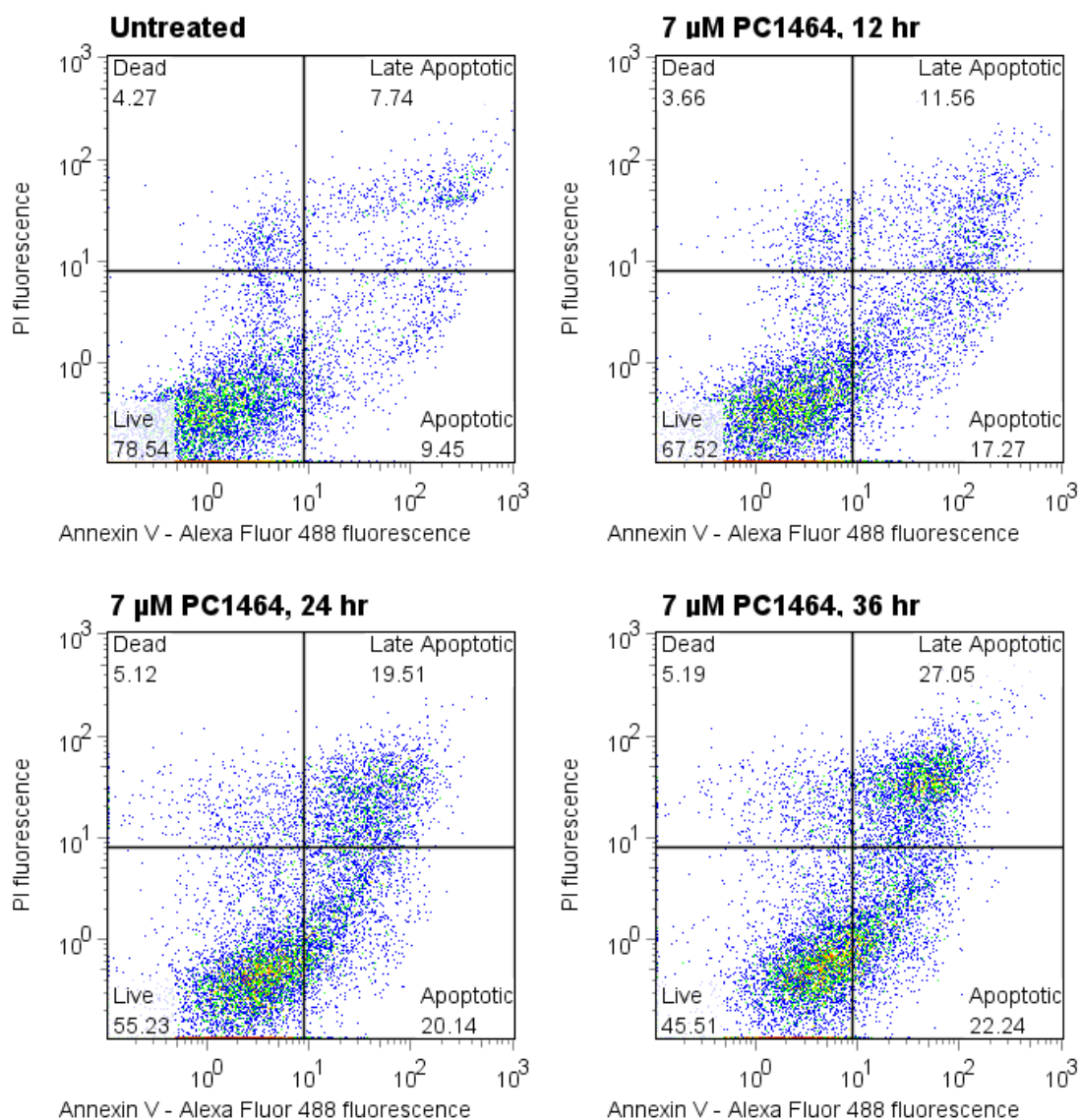

Figure 4.47. Apoptosis in human breast cancer cells (MDA-MB-231) treated with 7 μM Segetoside I for various times measured using the Vybrant® Apoptosis Assay Kit #2.

4.8.6. Failure of Segetoside I (MW 1464) to stimulate apoptosis in human fibroblast normal cells (CRL-2522)

Human fibroblast normal cell (CRL-2522) were treated with Segetoside I as previously described for Segetoside H. Apoptosis assays were carried out as described above.

The Dual Sensor: MitoCaspTM Assay was used to analyze CRL-2522 cells treated with 7 μ M Segetoside I for various times as shown in Table 4.31 and Fig. 4.48 below. Segetoside I had a minimal effect on CRL-2522 cells. There was a modest increase in cells with caspase 3/7 activity compared to untreated CRL-2522 cells; however such increases are expected during the aging of the cultures. Essentially no changes in cells with decreased mitochondrial membrane potential were detected.

Table 4.31. Apoptosis in human fibroblast normal cells (CRL-2522) treated with 7 μ M Segetoside I for various times measured using the Dual Sensor: MitoCaspTM Assay.

7 μ M Segetoside I	Cells with caspase 3/7 activity (%)	Cells with decreased mitochondrial membrane potential (%)
Untreated	2.7	3.9
10 hr	3.2	4.4
20 hr	11.7	4.4
30 hr	16.9	5.1

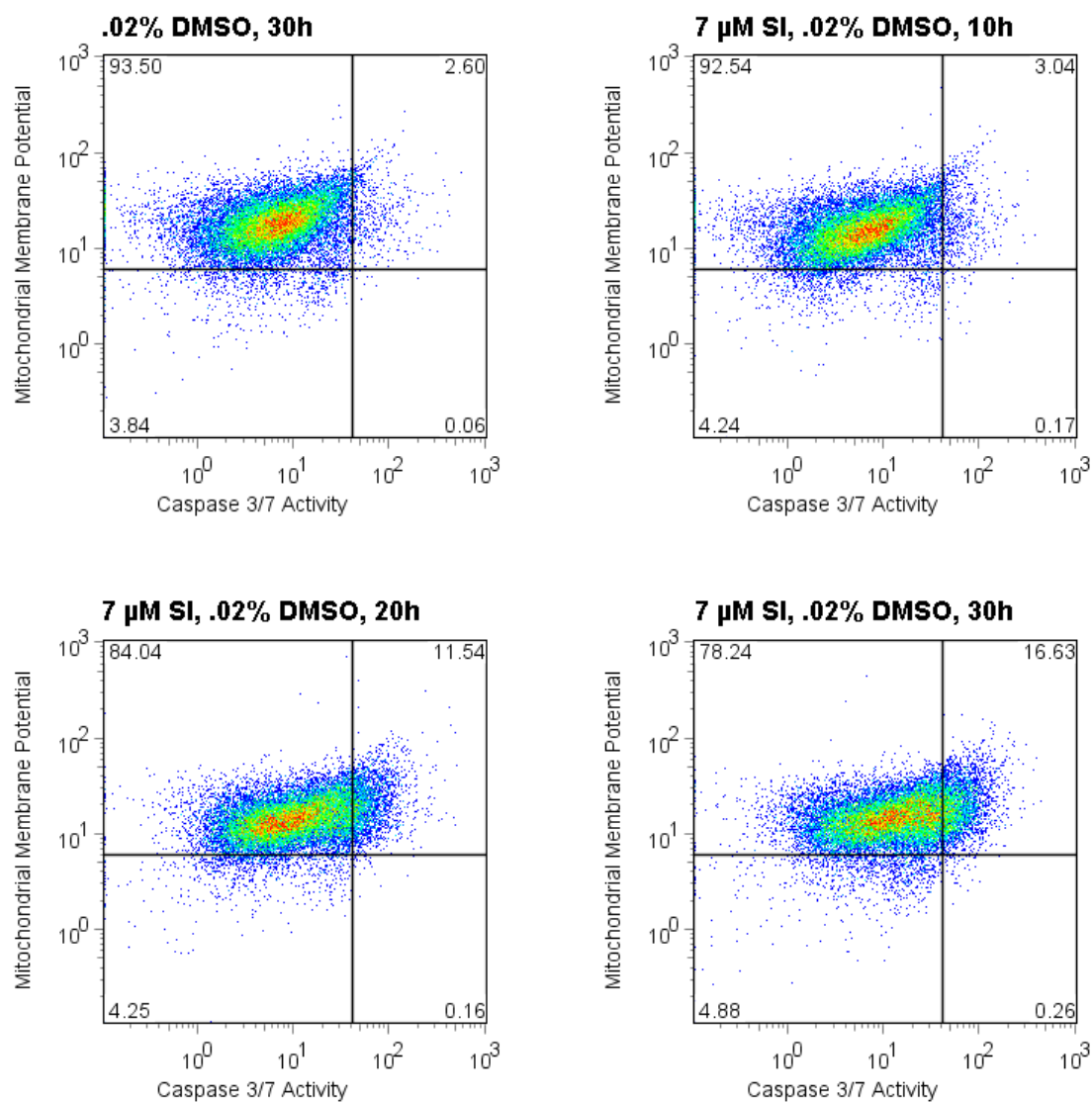

Figure 4.48. Apoptosis in human fibroblast normal cells (CRL-2522) treated with 7 μ M Segetoside I for various times measured using the Dual Sensor:MitoCaspTM Assay.

These results were confirmed with the Vybrant[®] Apoptosis Assay Kit #2. Following treatment with 7 μ M Segetoside I for various times, the results in Table 4.32 and Fig. 4.49 below show that Segetoside I had little effect on CRL-2522 cells. The percent of Annexin V positive cells increased only modestly after a 30 hr exposure.

Table 4.32. Apoptosis in human fibroblast normal cells (CRL-2522) treated with 7 μ M Segetoside I for various times measured using the Vybrant[®] Apoptosis Assay Kit #2.

7 μM Segetoside I	Annexin-V positive cells (%)
Untreated	6.9
10 hr	6.0
20 hr	8.4
30 hr	10.2

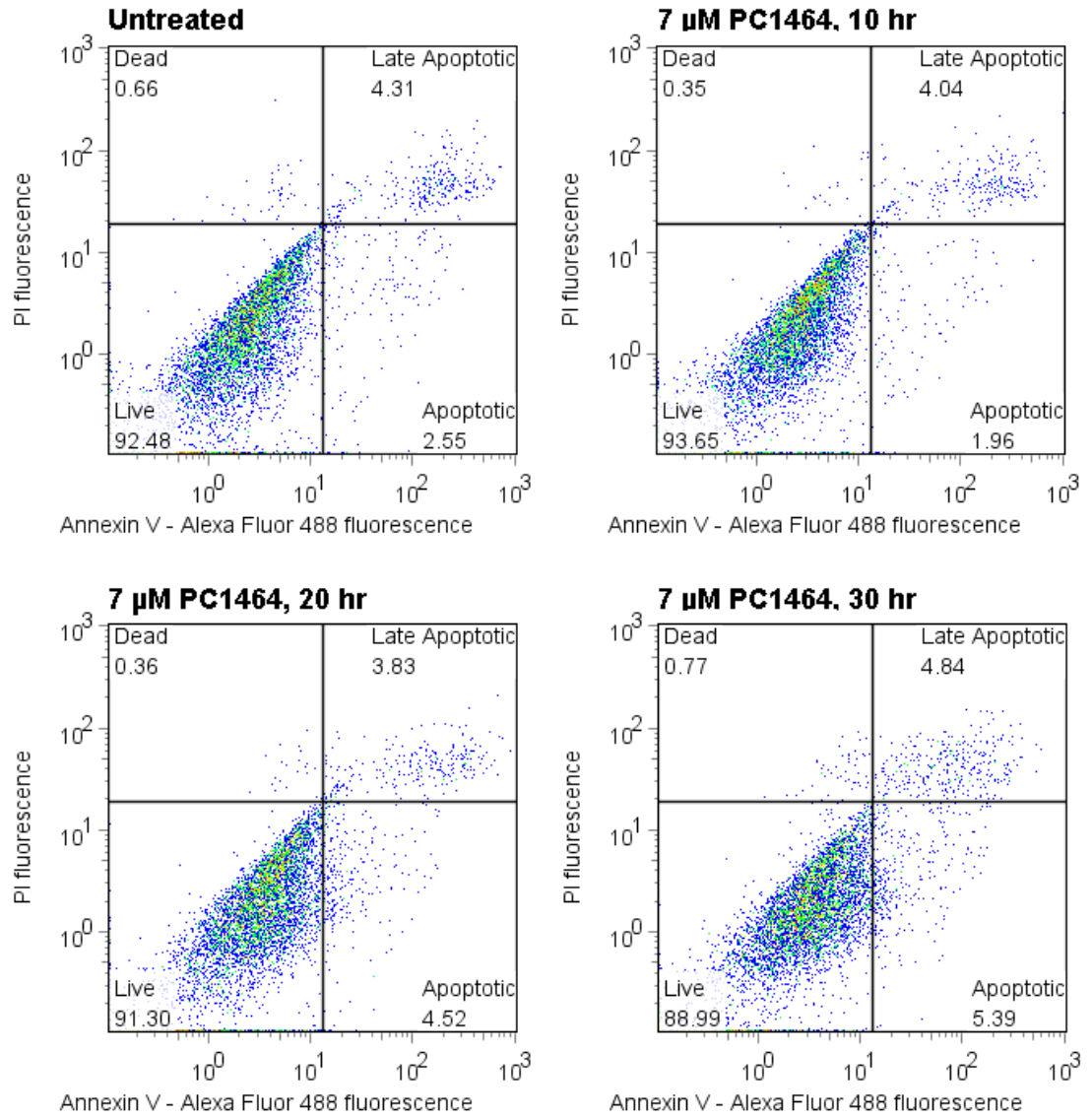

Figure 4.49. Apoptosis in human fibroblast normal cells (CRL-2522) treated with 7 μ M Segetoside I for various times measured using the Vybrant[®] Apoptosis Assay Kit #2.

4.9. Purification and cytotoxic evaluation of cyclopeptides from the seeds of *S. vaccaria* L.

During the exercise of purification of fractions from the methanol extracts of cow cockle seeds, three known cyclopeptides (segetalin A, B and D) and a new one, tentatively named segetalin I, were purified.

Cyclopeptide-enriched fractions were obtained as shown in section 3.8.5. Cyclopeptides were purified from the diethyl ether (Et₂O) insoluble fraction 'CP A,B,D+' by vacuum liquid chromatography (VLC). Five-grams of this fraction (5g) were fractionated by VLC. Fifteen 100 mL fractions were collected, aliquots were analysed by HPLC-PDA-MS, and crystal pure cyclopeptides segetalin A and B, 80% pure segetalin D and a new cyclopeptide, tentatively named segetalin I, were purified by consecutive preparative thin layer chromatography (PTLC) using a mixture of EtOAc:acetic acid:water (9:0.5:0.5, 4×). A chromatogram of the cyclopeptide-enriched fraction 'CP A,B,D+'s is shown below (Fig. 4.50).

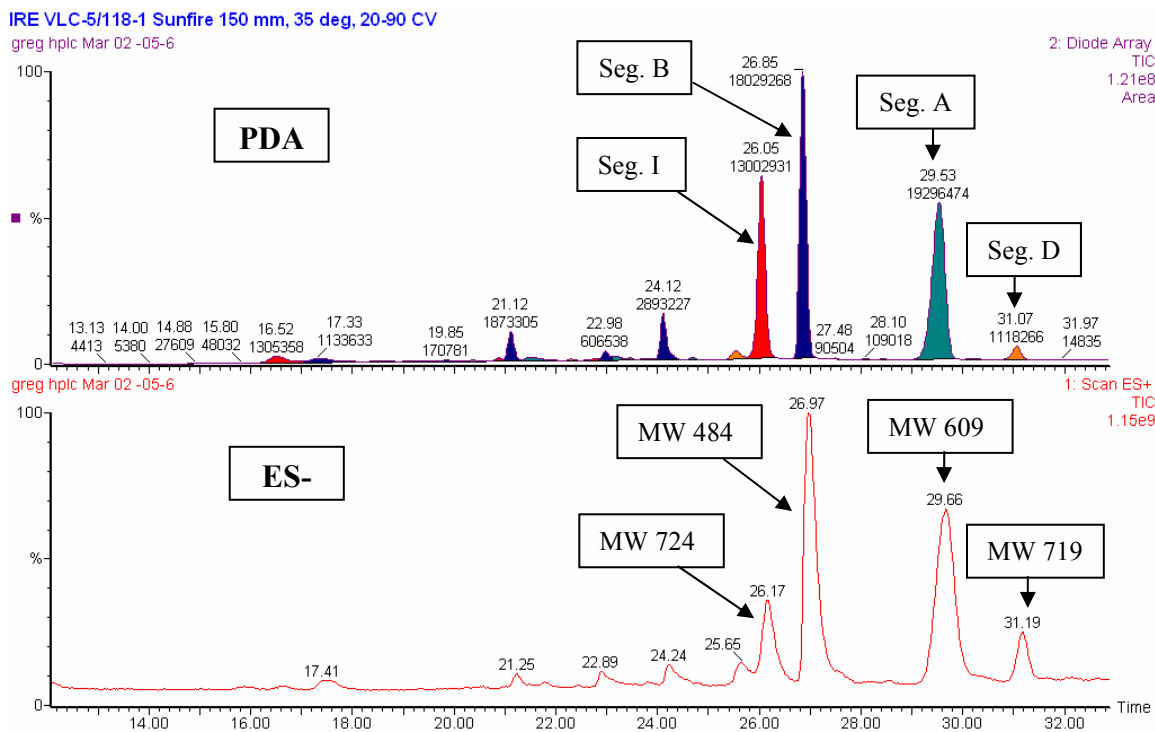
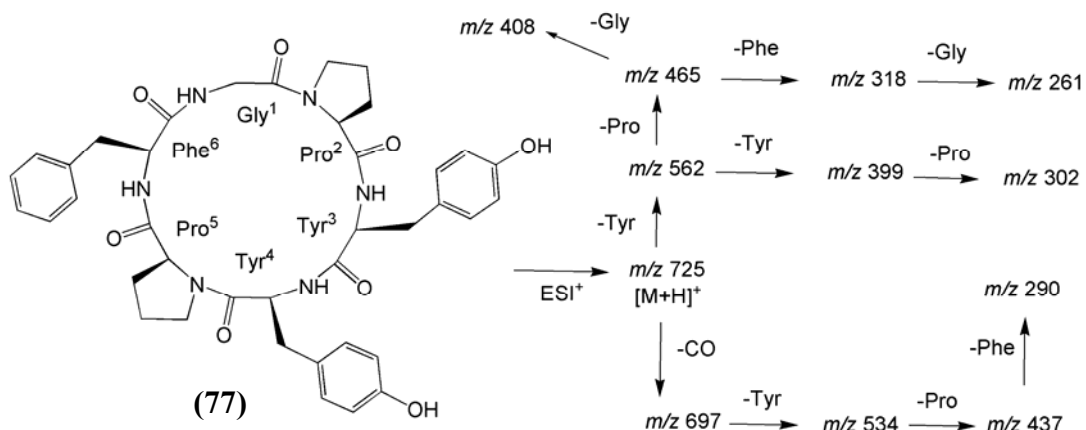

Figure 4.50. Cyclic peptide-containing fraction showing a mixture of segetalin A, B, D, and newly identified segetalin I.

The tentative structure of segetalin I was determined to be cyclo(Gly¹-Pro²-Tyr³-Tyr⁴-Pro⁵-Phe⁶) with a MW of 724.3208 (Fig. 4.51). Segetalin I has not been previously reported from any plant species.



Segetalin I (77). Amorphous off-white solid; $[\alpha]_D -3.0^\circ$ (c 1.1; H₂O); UV (MeOH): λ_{\max} 276, 283 nm; IR bands (KBr): 3400, 2996, 1680, 1574, 1418, 1136, 1043 cm⁻¹. MS (ESI⁺): see Fig. 4.12; MS (ESI⁻): m/z : 723 [M-H]⁻, 511, 430, 414, 212. HRMS molecular weight determination: calcd. for C₃₉H₄₄N₆O₈: 724.3220; found: 724.3208.

Figure 4.51. Structure of segetalin I (77), chemical analysis and diagnostic fragments observed in its mass spectrum (ESI⁺).

Pure and semi-pure cyclopeptides were also evaluated for cytotoxic activity on five cancer cell lines and two normal lines (Table 4.33), although it was previously reported that CP containing fractions did not show any activity (Table 4.6).

Purified cyclopeptides did not show any activity at the highest concentration tested (50 µg/mL).

Table 4.33. IC₅₀ values (µg/mL) of cyclic peptides from cow cockle seeds (*Saponaria vaccaria* L.) tested *in vitro* on five cancer cell lines (WiDr, colon; MDA-MB-231, breast; NCI-417, lung; PC-3, prostate; and Hs578T, breast) and two normal cell lines (CRL-2522, fibroblast and Hs578BST, breast) using the MTT bioassay. Cisplatin was used as a positive control.

	WiDr [‡]	MDA-MB-231 [‡]	NCI-417 [‡]	PC-3 [‡]	CRL-2522 [§]
IC ₅₀ (µg/ mL)					
Segetalin A	>50.0	>50.0	>50.0	>50.0	>50.0
Segetalin B	NS [†]	NS [†]	NS [†]	NS [†]	NS [†]
NEW Segetalin I (MW 724)	>50.0	>50.0	>50.0	>50.0	>50.0
Cisplatin	2.0 µM	11.7 µM	3.5 µM	3.7 µM	3.7 µM
	Hs578T [‡]	Hs578BST [§]			
NEW Segetalin I (MW 724)	>50.0	>50.0			

[†] NS = Not soluble

[‡] Cancer cell lines: WiDr (colon), MDA-MB 231 (breast), NCI-417 (lung), PC-3 (prostate), Hs578T (breast)

[§] Normal cell lines: CRL 2522 (fibroblast), Hs578BST (breast)

CHAPTER 5

CONCLUSIONS AND FUTURE WORK

5.1. Conclusions

This thesis work was part of a continuing interdisciplinary collaborative project between the University of Saskatchewan (Department of Pharmacology, College of Medicine) and the National Research Council of Canada-Plant Biotechnology Institute in Saskatoon. The main objective of this study was to investigate the biological activities of *Saponaria vaccaria* seed components particularly for their antitumor effects.

Initial agronomic studies showed that *Saponaria vaccaria*, a member of the Pink (carnation) family, grows well on the Canadian prairies and produced large quantities of seed that contains significant amounts of triterpene saponins. Subsequent studies on the saponin composition of four varieties of *S. vaccaria* collected from different sources showed that the bisdesmosidic saponins present in the seed were all similar albeit in different quantity. This supports other studies that have demonstrated that plants of the same species grown under different conditions (weather, soil, height, etc.) do not necessarily follow a unique metabolic profile.

Chromatographic separation techniques were applied for the fractionation and purification of saponins and cyclopeptides and were implemented to provide enough purified fractions for analysis and cytotoxic studies. Although the new saponin compounds were not completely purified, a methodology for the identification of known

and unknown triterpene saponins from *S. vaccaria* according to their fragmentation patterns using LC-MS-PDA was developed. This was a major finding that led to the identification of fourteen novel 3-*O*-trisaccharide saponins and seven new 3-*O*-disaccharides in addition to the previously reported 3-*O*-disaccharide saponins. This is the first time that 3-*O*-trisaccharide saponins are reported in *S. vaccaria*. As a result, a distinctive pattern was established that allowed the arrangement of all detected quillaja-type saponins into 3 types of families (Type I, Type II and Type III).

The cytotoxic activities of the triterpenoid saponin-containing fractions and the partially purified triterpenoid saponins isolated from *S. vaccaria* seed on four human cancer cell lines MDA-MB-231 (breast), PC-3 (prostate), WiDr (colon), and NCI-417 (lung) was established based on the 50 % inhibitory concentration (IC₅₀). The highest cytotoxicity obtained from the MTT assays from the seed extract of the 'Scott' variety may be attributed to its higher titer of 3-*O*-trisaccharide saponins in comparison with the other three varieties studied. When partially purified fractions eluted from the column chromatography separations of the seed methanol extract were evaluated for their cytotoxicity on the cancer cells, results showed that only the bisdesmosidic saponin-containing fractions possessed cytotoxic activity. The sugars-, phenolics-, cyclopeptides- and monodesmosidic saponins-containing fractions were not cytotoxic even at the highest concentrations tested (50 µg/mL). When the bisdesmosidic saponin-containing fractions were evaluated against the human fibroblast normal cell line CRL-2522, moderate cytotoxicity was also observed. However, the enhanced selectivity observed to the human breast cancer cell line MDA-MB-231 and to the human prostate cancer cell line PC-3 suggests a potentially enhanced therapeutic index. The partially

purified (80%) triterpene bisdesmosidic saponins showed similar cytotoxic activities than the less purified saponin-enriched fractions also suggesting that saponin structure might not be a limiting factor for the observed cytotoxic activity.

It was interesting noticing that most of the fractions tested showed increased inhibition of cells at the lowest concentrations tested (1.6 $\mu\text{g/mL}$ or lower). This effect, referred to as hormesis, is a common or important effect that has not been fully established. Although the idea that low dose effects may be different is accepted, it is still questionable that the low dose effect is positive. It has however been suggested that decreasing the dose not only produces quantitative changes in the response being measured but also qualitative changes. Although hormesis does not follow the standard linear-dose response model commonly accepted, several studies have been set to determine whether the concept of hormesis is valid, as well as biologically and toxicologically significant (Calabrese, 2004).

Due to the difficulty in the purification and isolation of individual saponins due to their close structural homology, chemical derivatizations were used to change both the saponin selectivity and IC_{50} values. Thus, semisynthesis was used to modify some of these components. The finding that these derivatized fractions were less active suggests that nature may have found the most active substances in evolution.

Preliminary histological studies showed that saponin-induced apoptosis occurs at a low dose and early incubation stage (~ 6 h). Stimulation of apoptosis by semi-purified bisdesmosidic saponins Segetoside H (MW 1448) and Segetoside I (MW 1464) on cancer cell lines MDA-MB-231 (breast) and PC-3 (prostate) was further studied and confirmed by flow cytometry. Selective cytotoxicity to cancer cell lines over the normal

cell line CRL-2522 (fibroblast) was remarkable since both saponins failed to induce apoptosis in the normal cell line.

A further contribution in the phytochemical identification of this plant was the isolation and identification of a number of cyclopeptides i.e. Segetalin A, B and new Segetalin I. Although these compounds did not show any activity against the cancer cell lines tested, cyclopeptides are known bioactive compounds which are of considerable research value.

In summary, we propose the triterpene bisdesmosidic saponins from the seed of *Saponaria vaccaria* as a new type of drug with potential antitumor/anticancer activity due to their ability to induce apoptosis *in vitro* in human cancer cell lines at low concentrations. Additionally, uses of other saponaria-derived compounds (cyclopeptides, phenolics) may provide useful tools in the development of additional medicinal uses. These compounds are extracted from a plant that can be easily cultivated in the Canadian Prairies using conventional farm machinery.

5.2. Future Work

Following the investigations described in this dissertation, a number of projects could be taken up, involving:

- Further purification of bisdesmosidic saponins from the seed of *Saponaria vaccaria* by the use of diverse chromatographic techniques;
- Evaluation of the cytotoxic activity on a larger panel of cancer cell lines;
- Evaluation of toxicity of purified saponins in outbred mice in order to obtain LD₅₀ values;
- Administration of one or more saponin-containing formulations of unknown efficacy to tumor-bearing mice and monitoring and measurement of tumor growth;
- Formulation studies of saponins with conventional anticancer agents, or as adjuvants;
- Additionally reference chemotherapeutic agents (positive control) and negative controls to be similarly administered and maintained;
- Studies on the biological properties of cyclopeptides isolated from *S. vaccaria*.

CITED LITERATURE

- Arneson, P. A. and Durbin, R. D. 1968. Studies on the mode of action of tomatine as a fungitoxic agent. *Plant Physiology* **43**: 683-686.
PMID: 5661492
- Baehrecke, E. H. 2002. How death shapes life during development. *Nature Reviews Molecular Cell Biology* **3**: 779-787.
DOI: 10.1038/nrm931
- Balsevich, J. J.; Bishop, G. G., and Ramirez-Erosa, I. 2006. Analysis of Bisdesmosidic Saponins in *Saponaria vaccaria* L. by HPLC-PDA-MS: Identification of New Quillaic Acid and Gypsogenin 3-O-Trisaccharides". *Phytochemical Analysis* **17**: 414-423.
DOI: 10.1002/pca.943
- Barr, I. G., Sjolander, A., and Cox, J. C. 1998. ISCOMs and other saponin based adjuvants (Review). *Advanced Drug Delivery Reviews*: **32**, 247-271.
DOI: 10.1016/S0169-409X(98)00013-1
- Begley, M. J., Crombie, L., Crombie, W. M. L. and Whiting, D. A. 1986. The isolation of avenacins A-1, A-2, B-1, and B-2, chemical defences against cereal 'take-all' disease. Structure of their 'aglycones', the avenestergens, and their anhydro dimers. *Journal of the Chemical Society, Perkin Transactions* **1**: 1905-1915.
DOI: 10.1039/P19860001905
- Calabrese, E. 2004. Hormesis: a revolution in toxicology, risk assessment and medicine. *European Molecular Biology Organization (EMBO)* **5**(1): S37-S40.
DOI: 10.1038/sj.embor.7400222.

Campbell, M. J., Hamilton, B., Shoemaker, M., Tagliaferri, M., Cohen, I., and Tripathy, D. 2002. Antiproliferative activity of Chinese medicinal herbs on breast cancer cells *in vitro*. *Anticancer Research* **22**: 3843-3852.

PMID: 12553004 Cited in SCOPUS database

Canada Seeds Act 1986: Weed Classes. 14. Cow cockle (*Saponaria vaccaria* L.) Class 3. Secondary noxious weed seeds.

<http://laws.justice.gc.ca/en/S-8> (Weed Seeds Order, 1986, Weed Seeds Order, 2005)

http://laws.justice.gc.ca/en/showdoc/cr/SOR-86-836/bo-ga:s_1::bo-gas:s_2?page=2

Caryophyllaceae. 2008. In: *Encyclopædia Britannica*. Retrieved January 20, 2008, from Encyclopædia Britannica Online: <http://search.eb.com/eb/article-9020585>.

Cheng, G., Zhang, Y., Zhang, X., Tang, H-F., Cao, W-D., Gao, D-K., and Wang, X-L. 2006. Tubeimoside V (1), a new cyclic bisdesmoside from tubers of *Bolbostemma paniculatum*, functions by inducing apoptosis in human glioblastoma U87MG cells. *Biororganic and Medicinal Chemistry Letters* **16**(17): 4575-4580.

DOI: 10.1016/j.bmcl.2006.06.020

Cheng, C. Y., Urbani, M. D., Mioviski, P., Kittelty, D., Otero, A. F., and San Martin, R. M. 2004. Evaluation of saponins as acid mist suppressants in zinc electrowinning. *Hydrometallurgy* **73**(1-2): 133-145.

DOI: 10.1016/j.hydromet.2003.10.001

Chopra, R. N., Nayar, S. L., and Chopra, I. C. 1956. Glossary of Indian Medicinal Plants. Council of Scientific and Industrial Research, New Delhi, India.

ISBN-10: 8172361262

- Corea, G., Fattorusso, E., Lanzotti, V., Capasso, R., and Izzo, A. A. 2005. Antispasmodic saponins from bulbs of red onion, *Allium cepa* L. var. Tropea. *Journal of Agricultural and Food Chemistry* **53**(4): 935-940.
DOI: 10.1021/jf048404o
- Crombie, W. M. L. and Crombie, L. 1986. Distribution of avenacins A-1, A-2, B-1 and B-2 in oat roots: their fungicidal activity towards “take all” fungus. *Phytochemistry* **25**(9): 2069-2073.
DOI: 10.1016/0031-9422(86)80068-1
- Cuconati, A. and White, E. 2002. Viral homologues of Bcl-2: role of apoptosis in the regulation of virus infection. *Genes and Development* **16**: 2465-2478.
DOI: 10.1101/gad.1012702
- Dales, J. P., Palmerini, F., Devilard, E., Hassoun, J., Birg, F., and Xerri, L. 2001. Caspases: conductors of the cell death machinery in lymphoma cells. *Leukemia and Lymphoma* **41**(3-4): 247-253.
ISSN: 1042-8194 PMID: 11378538
- Davis, E. A. and Morris, D. J. 1991. Medicinal uses of licorice through the millennia: the good and the plenty of it. *Molecular and Cellular Endocrinology* **78**(1-2): 1-6.
DOI: 10.1016/0303-7207(91)90179-V
- De Tomassi, N., Autore, G., Bellino, A., Pinto, A., Pizza, C., Sorrentino, R., and Venturella, P. 2000. Antiproliferative triterpene saponins from *Travesia palmata*. *Journal of Natural Products* **63**: 308-314.
DOI: 10.1021/np990231n
- Deng, S., Yu, B., Lou, Y., and Hui, Y. 1999. First total synthesis of an exceptionally potent antitumor saponin, OSW-1. *Journal of Organic Chemistry* **64**: 202-208.

DOI: 10.1021/jo981685c

Digitalis. 2008. In: *Encyclopædia Britannica*. Retrieved January 20, 2008, from Encyclopædia Britannica Online: <http://search.eb.com/eb/article-9030433>.

Duke, J. A. and Ayensu, E. S. 1985. *Medicinal Plants of China (Medicinal Plants of the World)*. Algonac, Mich.: Reference Publications.

ISBN-10: 0917256204

Durkin, W. J., Ghanta, V. K., Balch, C. M., Davis, D. W., and Hiramoto, R. N. 1979. A methodological approach to the prediction of anticancer drug effect in humans. *Cancer Research* **39**: 402-407.

PMID: 761212

Fenwick, G. R., Price, K. R., Tsukamota, C., and Okubo, K. 1991. Saponins. In: D'Mello, J. P. F., Duffus, C. M., Duffus, J. H. (eds). *Toxic substances in crop plants*. The Royal Society of Chemistry, Cambridge, UK, p. 284.

ISBN-10: 0851868630

Fenwick, G. R., Lutomski, J., and Nieman, C. 1990. Licorice, *Glycyrrhiza glabra* L.- Composition, uses and analysis. *Food Chemistry* **38**(2): 119-143.

DOI: 10.1016/0308-8146(90)90159-2

Ferreira, F. and Llodrá, J. 2000. Glycoside based adjuvants. In: *Saponins in food, feedstuffs and medicinal plants*. Proceedings of the phytochemical society of Europe Vol. 45. W. Oleszek and A. Marston, eds. Kluwer Academic Pub., Dordrecht, The Netherlands, pp. 233-240.

ISBN-10: 0792360230

- Fiebig, M., Duh, C-Y., Pezzuto, J. M., Kinghorn, A. D., and Farnsworth, N. R. 1985. Plant anticancer agents, XLI. Cardiac glycosides from *Streblus asper*. *Journal of Natural Products* **48**: 981-985
PMID: 4093781
- Francis, G., Karem, Z., Makkar, H. P. S., and Becker, K. 2002. The biological action of saponins in animal systems: a review. *British Journal of Nutrition* **88**: 587-605.
DOI: 10.1079/BJN2002725
- Gaidi, G., Correia, M., Chauffer, Beltramo, J-L., Wagner, H., and Lacaille-Dubois, M. A. 2002. Saponins-mediated potentiation of cisplatin accumulation and cytotoxicity in human colon cancer cells. *Planta Medica* **68**: 70-72.
DOI: 10.1055/s-2002-19873
- Goering, K. J., Eslick, R. F., Watson, C. A., and Keng, J. 1966. Utilization and agronomic studies of cow cockle (*Saponaria vaccaria*). *Economic Botany* **20**: 430-433.
(No electronic version available)
- Global Biodiversity Information Facility...Free and open access to biodiversity data.
Genus: *Saponaria*. <http://data.gbif.org/species/13195156>.
- Glüçlü-Üstlündag, Ö. and Mazza, G. 2007. Saponins: properties, applications and processing. *Critical Reviews in Food Science and Nutrition* **47**: 231-258.
DOI: 10.1080/10408390600698197 ISSN: 1040-8398
- Glüçlü-Üstlündag, Ö., Balsevich, J., and Mazza, G. 2007. Pressurized low polarity water extraction of saponins from cow cockle seed. *Journal of Food Engineering* **80**(2): 619-630.
DOI: 10.1016/j.jfoodeng.2006.06.024

Hanusek, M., Ganesh, P., Walaszek, Z., Arntzen, C. J., Slaga, T. J., and Gutterman, J. U. 2001. Avicins, a family of triterpenoid saponins from *Acacia victoriae* (Benth), suppress H-ras mutations and aneuploidy in a murine skin carcinogenesis model. *Proceedings of the National Academy of Sciences USA* **98**: 11551-11556.
DOI: 10.1073/pnas.191363198 PMID: 11572997

Haridas, V., Higuchi, M., Jayatilake, G. S., Bailey, D., Mujoo, K., Blake, M. E., Arntzen, C. J., and Gutterman, J. U. 2001. Avicins: Triterpenoid saponins from *Acacia victoriae* (Benth) induce apoptosis by mitochondrial perturbation. *Proceedings of the National Academy of Sciences of the United States of America* **98**: 5821-5826.
DOI: 10.1073/pnas.101619098

Henderson, S., Huen, D., Rowe, M., Dawson, C., Johnson, G., and Rickinson, A. 1993. Epstein-Barr virus-coded BHRF1 protein, a viral homologue of Bcl-2, protects human B cells from programmed cell death. *Proceedings of the National Academy of Sciences of the United States of America* **90**: 8479-8483.
PMCID: PMC47380

Hostettmann, K., Hostettmann, M., and Marston, M. 1991. Saponins. In: Charlwood, B. V. and Banthorpe, D. V. (eds.). *Methods in Plant Biochemistry Vol. 7, Terpenoids* (Series Eds., P. M. Dew and J. B. Harborne). Academic Press, London UK, pp. 435-471.
ISBN: 0-12-461017-X

Hostettmann, K. A. and Marston, A. 1995. *Saponins. Chemistry and pharmacology of natural products*. Cambridge University Press, Cambridge, UK.
ISBN-10: 0521329701

- Houston, A. And O'Connell, J. 2004. The Fas signalling pathway and its role in the pathogenesis of cancer. *Current Opinion in Pharmacology* **4**(4): 321-326.
DOI: 10.1016/j.coph.2004.03.008
- Israels, L. G. and Israels, E. D. 1999. Lymphocytes. *The Oncologist* **4**(2): 129-137.
PMID: 10337383
<http://www.TheOncologist.com/cgi/content/full/4/2/129>
- Itokawa, H., Yun, Y., Morita, H., Takeya, K., and Yamada K. 1995. Estrogen-like activity of cyclic peptides from *Vaccaria segetalis* extracts. *Planta Medica* **61**: 561-562.
DOI: 10.1055/s-2006-959373
- Ivanov, L. V., Khadzhai, Y. I., Chueva, I. I., and Vasselovskii, V. Y. 1988. Effects of escin on biological membranes. *Pharmaceutical Chemistry Journal* **22**(12): 875-878.
DOI: 10.1007/BF00771637
- Jackson, S.J., Houghton, P. J., Retsas, S., and Photiou, A. 2000. *In vitro* cytotoxicity of norviburtinal and isopinnatal from *Kigelia pinnata* against cancer cell lines. *Planta Medica* **66**: 758-761.
DOI: 10.1055/S-2000-9778 PMID: 11199138
- Jakubowski, H. 2008. Chapter 9- Signal Transduction. D: Apoptosis: Programmed Cell Death. Biochemistry online: an approach based on chemical logic.
<http://employees.csbsju.edu/hjakubowski/classes/ch331/bcintro/default.html>
- Jia, Z., Koike, K., Kudo, M., Li, H., and Nakaido, T. 1998. Triterpenoid saponins and sapogenins from *Vaccaria segetalis*. *Phytochemistry* **48**(3): 529-536.
DOI: 10.1016/S0031-9422(97)01128-X PMID:9654779

- Joshi, L., Van Eck, J. M., Mayo, K., Di Silvestro, R., Blake (Nieto), M. E., Ganapathi, T., Haridas, V., Gutterman, J. U., and Arntzen, C. J. 2002. Metabolomics of plant saponins: Bioprospecting Triterpene Glycoside diversity with respect to mammalian cell targets. *OMICS A Journal of Integrative Biology*: **6**(3), 235-246.
DOI: 10.1089/15362310260256891
- Kang, J-H., Sung, M-K., Kawada, T., Yoo, H., Kim, Y-K., Kim, J-S., and Yu, R. 2005. Soybean saponins suppress the release of proinflammatory mediators by LPS-stimulated peritoneal macrophages. *Cancer Letters* **230**(2): 219-227.
DOI: 10.1016/j.canlet.2004.12.041
- Kensil, C. R. 1996. Saponins as vaccine adjuvants. *Critical Reviews in Therapeutic Drug Carrier Systems*: **13**, 1-55.
(No electronic version available)
- Koike, K., Zhonghua, J., and Nakaido, T. 1998. Triterpenoid saponins from *Vaccaria segetalis*. *Phytochemistry* **47**(7): 1343-1349.
DOI: 10.1016/S0031-9422(97)00707-3 PMID: 9611829
- Koike, S. T., Henderson, D. M., Tjosvold, S.A., and Simmons, E. G. 1999. Outbreak of leaf spot of Saponaria caused by *Alternaria saponariae* in California. *Plant Disease*: **83**, 694.
DOI: 10.1094/PDIS.1999.83.7.694A
- Kubo, S., Mimaki, Y., Terao, M., Sashida, Y., Nikaido, T., and Ohmoto, T. 1992. Acylated cholestane glycosides from the bulbs of *Ornithogalum saundersiae* **31**(11): 3969-3973.
DOI: 10.1016/S0031-9422(00)97565-4
- Kuroda, M., Mimaki, Y., Sashida, Y., Kitahara, M., Yamazaki, M., and Yui, S. 2001. Securosides A and B, novel acylated triterpene bisdesmosides with selective

cytotoxic activity against M-CSF-stimulated macrophages. *Bioorganic and Medicinal Chemistry Letters* **11**: 371-374.

DOI: 10.1016/S0960-894X(00)00674-0

Lacaille-Dubois, M. A. 2000. Biologically and pharmacologically active saponins from plants: recent advances. In: *Saponins in food, feedstuffs and medicinal plants*. Proceedings of the Phytochemical Society of Europe Vol. 45. W. Oleszek and A. Marston, eds. Kluwer Academic Pub., Dordrecht, The Netherlands, pp. 205-218. ISBN-10: 0792360230

Lee, K. J., Shin, D. W., Chung, Y. C., and Jeong, H. G. 2006. Chemopreventive effect of saponins derived from roots of *Platycodon grandiflorum* on 4-(methylnitrosamino)-1-(3-pyridyl)-1-butanone-induced lung tumorigenesis in A/J mice. *Archives of Pharmacal Research* **29**(8): 651-656.

ISSN: 0253-6269 PMID: 16964760 (no DOI available)

Licorice. 2008. In: *Encyclopædia Britannica*. Retrieved January 20, 2008, from Encyclopædia Britannica Online: <http://search.eb.com/eb/article-9048159>.

Ma, H., Shieh, K.-J., and Chen, G. 2005. Apoptosis. *Nature and Science* **3**(2): 1-4.

ISSN 1545-0740 <http://www.sciencepub.org/nature/0302/>

Ma, X., Yu, B., Hui, Y., Miao, Z., and Ding, J. 2001. Synthesis of OSW-1 analogues and a dimer and their antitumor activities. *Bioorganic and Medicinal Chemistry Letters* **11**: 2153-2156.

DOI: 10.1016/S0960-894X(01)00389-4

Marston, A., Wolfender, J.-L., and Hostettmann, K. 2000. Analysis and isolation of saponins from plant material. In: *Saponins in food, feedstuffs and medicinal plants*. Proceedings of the Phytochemical Society of Europe Vol. 45. W.

Oleszek and A. Marston, eds. Kluwer Academic Pub., Dordrecht, The Netherlands, pp. 1-12.

ISBN-10: 0792360230

Matsuda, H., Li, Y., Murakami, T., Ninomiya, K., Araki, N., Yoshikawa, M., and Yamahara, J. 1997. Antiinflammatory effects of escins Ia, Ib, Iia, and Iib from horse chestnut, the seeds of *Aesulus hippocastanum* L. *Bioorganic and Medicinal Chemistry Letters* **7**(13): 1611-1616.

DOI: 10.1016/S0960-894X(97)00275-8

Mazza, G., Biliaderis, C. G., Przybylski, R, and Oomah, B. D. 1992. Compositional and morphological characteristics of cow cockle (*Saponaria vaccaria*) seed, a potential alternative crop. *Journal of Agricultural and Food Chemistry* **40**(9): 1520-1523.

DOI: 10.1021/jf00021a009

Mimaki, Y., Harada, H., Sakuma, C., Haraguchi, M., Yui, S., Kudo, T., Yamazaki, M., and Sashida, Y. 2003. Enterolosaponins A and B, novel triterpene bisdesmosides from *Enterolobium contortisiliquum*, and evaluation for their macrophage-oriented cytotoxic activity. *Bioorganic and Medicinal Chemistry Letters* **13**: 623-627.

DOI: 10.1016/S0960-894X(02)01044-2

Ministry of Agriculture, Food and Rural Affairs. 2002. Ontario Weeds: Cow cockle.

http://www.omafra.gov.on.ca/english/crops/facts/ontweeds/cow_cockle.htm#name.

Montana Plant Life – Flora and Identification Edible, Medicinal and Poisonous Plants.

<http://montana.plant-life.org/index.html>

- Morita, H., Eda, M., Iizuka, T., Hirasawa, Y., Sekiguchi, M., Yun, Y-S., Itokawa, H., and Takeya, K. 2006. Structure of a new cyclic nonapeptide, segetalin F, and vasorelaxant activity of segetalins from *Vaccaria segetalis*. *Bioorganic and Medicinal Chemistry Letters* **16**: 4458-4461.
DOI: 10.1016/j.bmcl.2006.06.083
- Morita, H., Yun, Y-S., Takeya, K., Itokawa, H., Yamada, K., and Shirota, O. 1997. Vaccaroid A, a new triterpenoid saponin with contractility of rat uterine from *Vaccaria segetalis*. *Bioorganic and Medicinal Chemistry Letters* **7**(8):1095-1096.
DOI: 10.1016/S0960-894X(97)00168-6
- Morita, H., Yun, Y-S., Takeya, K., Itokawa, H., and Yamada, K. 1995. Segetalins B, C and D, three new cyclic peptides from *Vaccaria segetalis*. *Tetrahedron* **51**(21): 6003-6014.
DOI: 10.1016/0040-4020(95)00278-G
- Morrissey, J. P. and Osbourn, A. E. 1999. Fungal resistance to plant antibiotics as a mechanism of pathogenesis. *Microbiology and Molecular Biology Reviews* **63**(3): 708-724.
PMID: 10477313
<http://www.pubmedcentral.gov/articlerender.fcgi?artid=103751>
- Mujoo, K., Haridas, V., Hoffmann, J. J., Wachter, G. A., Hutter, L. K., Lu, Y., Blake M. E., Jayatilake, G. S., Bailey, D., Mills, G. B., and Gutterman, J. U. 2001. Triterpenoid saponins from *Acacia victoriae* (Benth) decrease tumor cell proliferation and induce apoptosis. *Cancer Research* **61**: 5486-5490.
PMID: 11454696
- Natural Resources Canada. *Vaccaria hispanica*. www.nrcan-rncan.gc.ca.

- Oakenfull, D. G. and Topping, D. L. 1983. Saponins and plasma cholesterol. A reply to the letter of Gibney, Pathirana and Smith. *Atherosclerosis* **48**: 301-303.
DOI: 10.1016/0021-9150(83)90048-5 PMID: 6639710
- Oh, S-H. and Lee, B-H. 2004. A ginseng saponin metabolite-induced apoptosis in HepG2 cells involves a mitochondria-mediated pathway and its downstream caspase-8 activation and Bid cleavage. *Toxicology and Applied Pharmacology* **194**(3): 221-229.
DOI: 10.1016/j.taap.2003.09.011
- Oh, Y-J. and Sung, M-K. 2001. Soybean saponin inhibit cell proliferation by suppressing PKC activation and induce differentiation of HT-29 human colon adenocarcinoma cells. *Nutrition and Cancer* **39**(1): 132-138.
DOI: 10.1207/S15327914nc391_18
- Oleszek, W. A. Chromatographic determination of plant saponins. 2002. *Journal of Chromatography A* **967**: 147-162.
DOI: 10.1016/S0021-9673(01)01556-4 PMID: 12219927
- Osbourn, A. 1996. Saponins and plant defence – a soap story. *Trends in Plant Science* **1**(1): 4-9.
DOI: 10.1016/S1360-1385(96)80016-1
- Osbourn, A. E., Qi, X., Townsend, B., and Qin, B. 2003. Dissecting plant secondary metabolism –constitutive chemical defences in cereals. *New Phytologist* **159**(1): 101-108. (No electronic version available)
- Pagé, M. 1997. High-Volume Screening. In: *Anticancer Drug Development Guide. Preclinical Screening, Clinical Trials, and Approval, Part I. In vitro Methods*. B. A. Teicher, ed. Human Press, Totowa, N. J., pp. 3-21.
DOI: 10.1226/0896034615 ISBN: 2588292282

Pelletier, S. W., Chokshi, H. P., and Desai, H. K. 1986. Separation of diterpenoid alkaloid mixtures using vacuum liquid chromatography. *Journal of Natural Products* **49**(5): 892-900.

DOI: 10.1021/np50047a021

Pitti, R. M., Marsters, S. A., Lawrence, D. A., Roy, M., Kischkel, F. C., Dowd, P., Huang, A., Donahue, C. J., Sherwood, S. W., Baldwin, D. T., Godowski, P. J., Wood, W. I., Gurney, A. L., Hillan, K. J., Cohen, R. L., Goddard, A. D., Botstein, D., and Ashkenazi, A. 1998. *Nature* **396**(6712): 699-703.

DOI: 10.1038/25387

Plants for a future: *Saponaria officinalis* database with References. 1997-2000.

http://www.ibiblio.org/pfaf/cgi-bin/arr_html?Saponaria+officinalis

Plants for a future: *Vaccaria hispanica* database with References. 1997-2000.

http://www.ibiblio.org/pfaf/cgi-bin/arr_html?Vaccaria+hispanica

Platt, N., da Silva, R. P., and Gordon, S. 1999. Class A scavenger receptors and the phagocytosis of apoptotic cells. *Immunology Letters* **65**(1-2): 15-19.

DOI: 10.1016/S0165-2478(98)00118-7 PMID: 10065621

Price, K. R., Johnson, I. T., and Fenwick, G. R. 1987. The chemistry and biological significance of saponins in foods and feeding stuffs. *CRC Critical Reviews in Food Science and Nutrition* **26**: 27-135.

ISSN: 1040-8398

Promega Technical Bulletin No. 112. 1999. CellTiter 96[®] Non-radioactive Cell Proliferation Assay. Promega Corp., Madison, WI., pp. 1-13.

PubMed: <http://www.ncbi.nlm.nih.gov/PubMed/>

- Rabeler, R. K. and Hartman, R. L. 2005. Flora of North America. Vol. 5.
<http://www.eFloras.org>
- Rahimtoola, S. H. 2004. Digitalis therapy for patients in clinical heart failure.
Circulation **109**: 2942-2946.
DOI: 10.1161/01.CIR.0000132477.32438.03
- Rahimtoola, S. H. And Tak, T. 1996. The use of digitalis in heart failure. *Current Problems in Cardiology* **21**(12): 781-853.
DOI: 10.1016/S0146-2806(96)80001-6
- Rao, A. V. 1997. Anticarcinogenic properties of plant saponins. *Vegetarian Nutrition* **1**(3): 86-93.
AGRIS record No.: GB1997050779
- Rao, A. V. and Gurfinkel, D. M. 2000. The bioactivity of saponins: triterpenoid and steroidal glycosides. *Drug Metabolism and Drug Interactions* **17** (1-4): 211.
PMID: 11201296
- Rao, A. V. and Sung, M. K. 1995. Saponins as anticarcinogens. *Journal of Nutrition* **125** (3 Suppl.): 717S-724S.
ISSN: 0022-3166/95 PMID: 7884557
http://jn.nutrition.org/cgi/reprint/125/3_Suppl/7175.pdf
- Rathbone, J. and McMonagle, T. 2000. Pimozide for schizophrenia or related psychoses.
Cochrane Database of Systematic Reviews. Issue 1. Art. No.: CD001949.
DOI: 10.1002/14651858.CD001949.pub2
- Rich, T., Allen, R.L., and Wyllie, A. H. 2000. Defying death after DNA damage. *Nature* **407**: 777-783.
DOI: 10.1038/35037717

- Roddick, J. G. 1974. The steroidal glycoalkaloid tomatine. *Phytochemistry* **13**: 9-25.
DOI: 10.1016/S0031-9422(00)91261-5
- San Martin, R. and Briones, R. 2000. Quality control of commercial quillaja (*Quillaja saponaria* Molina) extracts by reverse phase HPLC. *Journal of the Science of Food and Agriculture*. **80**(14): 2063-2068.
DOI: 10.1002/1097-0010(200011)80:14<2063::AID-JSFA750>3.0.CO;2-2
- San Martin, R. and Briones, R. 1999. Industrial uses and sustainable supply of *Quillaja saponaria* (Rosaceae) saponins. *Economic Botany* **53**: 302-311.
ISSN: 0013-0001 (No electronic version available)
- Sang, A. L., Chen, Z., Uzawa, J., and Fujimoto, Y. 2003. Chemistry and bioactivity of seeds of *Vaccaria segetalis*. In: Oriental foods and herbs: chemistry and health effects. C. T. Ho, J. K. Lin, and Q. Y. Zheng, eds. American Chemical Society, Washington, D.C., pp. 279-291.
ISBN 10: 0841238413
- Sang, S-M., Xia, Z-H., Lao, A-N., Cao, L., Chen, Z-L., Uzawa, J., and Fujimoto, Y. 2003. Studies on the constituents of the seeds of *Vaccaria segetalis*. *Heterocycles* **59**(2): 811-821
ISSN: 0385-5414
- Sang, S-M., Lao, A-N., Leng, Y., Cao, L., Chen, Z-L., Uzawa, J., Shigeo, Y., and Fujimoto, Y. 2002. A new triterpenoid saponin with inhibition of luteal cell from the seeds of *Vaccaria segetalis*. *Journal of Asian Natural Products Research* **4**(4): 297-301.
DOI: 10.1080/1028602021000049096 PMID: 12450258

- Sang, S-M., Lao, A-N., Chen, Z-L., Uzawa, J., and Fujimoto, Y. 2000a. Three new triterpenoid saponins from the seeds of *Vaccaria segetalis*. *Journal of Asian Natural Products Research* **2**(3): 187-193.
DOI: 10.1080/10286020008039910 PMID: 11256692
- Sang, S-M., Lao, A-N., Leng, Y., Gu, Z-P., Chen, Z-L., Uzawa, J., and Fujimoto, Y. 2000b. Segetoside F a new triterpenoid saponin with inhibition of luteal cell from the seeds of *Vaccaria segetalis*. *Tetrahedron Letters* **41**(48): 9205-9207.
DOI: 10.1016/S0040-4039(00)01710-X
- Sang, S-M., Zou, M-L., Lao, A-N., Chen, Z-L., Uzuwa, J., and Fujimoto, Y. 2000c. A new triterpenoid saponin from the seeds of *Vaccaria segetalis*. *Chinese Chemical Letters* **11**(1): 49-53.
Cited in SCOPUS database
- Sang, S-M., Xia, Z-H., Mao, S-L., Lao, A-N., and Chen, Z-L. 2000d. Studies on the flavonol glycosides from the seeds of *Vaccaria segetalis*. *China Journal of Chinese Materia Medica (Zhongguo Zhong Yao Za Zhi)*: **25**(4): 221-222.
PMID: 12512436
- Sang, S-M., Lao, A-N., Wang, H-C., Chen, Z-L., Uzuwa, J., and Fujimoto, Y. 1999. Triterpenoid saponins from *Vaccaria segetalis*. *Journal of Asian Natural Products Research* **1**(3): 199-205.
DOI: 10.1080/10286029908039865 PMID: 11254032
- Sang, S-M., Lao, A-N., Wang, H-C., Chen, Z-L., Uzuwa, J., and Fujimoto, Y. 1998. Triterpenoid saponins from *Vaccaria segetalis*. *Natural Product Sciences* **4**(4): 268-273.
Cited in SCOPUS database.

- Schulze-Osthoff, K., Ferrari, D., Los, M., Wesselborg, S., and Peter, M. E. 1998. Apoptosis signalling by death receptors. *European Journal of Biochemistry* **254**(3): 439-459.
DOI: 10.1046/j.1432-1327.1998.2540439.x
- Sen, S., Makkar, H. P. S., Muetzel, S., and Becker, K. 1998a. Effect of *Quillaja saponaria* saponins and *Yucca schidigera* plant extract on growth of *Escherichia coli*. *Letters in Applied Microbiology* **27**(1): 35-38.
DOI: 10.1046/j.1472-765X.1998.00379.x
- Sen, S., Makkar, H. P. S., and Becker, K. 1998b. Alfalfa saponins and their implication in animal nutrition. *Journal of Agricultural and Food Chemistry* **46**: 131-140.
DOI: 10.1016/S0021-8561(97)00389-0
- Shoemaker, M., Hamilton, B., Dairkee, S. H., Cohen, I., and Campbell, M. J. 2005. *In vitro* anticancer activity of twelve Chinese medicinal herbs. *Phytotherapy research* **19**: 649-651.
DOI: 10.1002/ptr.1702
- Sieuwerts, A. M., Klijn, J. G. M., Peters, H. A., and Foekens, J. A. 1995. The MTT tetrazolium salt assay scrutinized: How to use this assay reliably to measure metabolic activity of cell cultures *in vitro* for the assessment of growth characteristics, IC₅₀-values and cell survival. *European Journal of Clinical Chemistry and Clinical Biochemistry* **33**: 813-823.
(Discontinued –now *European Journal of Clinical Investigation*. No electronic version available.)
- Sirtori, C. R. 2001. Aescin: pharmacology, pharmacokinetics and therapeutic profile. *Pharmacological Research* **44**(3): 183-193.
DOI: 10.1006/phrs.2001.0847

Smith, D. B., Roddick, J. G., and Jones, J. L. 1996. Potato glycoalkaloids: some unanswered questions. *Trends in Food Science and Technology* **7**(4): 126-131.
DOI: 10.1016/0924-2244(96)10013-3

Smith, F. P. 1969. Chinese Materia Medica: vegetable kingdom / F. Porter Smith; extensively revised from F. Porter Smith's work by G. A. Stuart. Taipei: Ku T'ing Book House; 2nd rev. ed. by D. Wei (1969).
ASIN: B0007ITUQ0
Oriental Book Store (Pub.); Reprint edition (Dec. 1979)
ISBN-10: 0899863094

Soengas, M. S., Capodeice, P., Polsky, D., Mora, J., Esteller, M., Opitz-Araya, X., McCombie, R., Herman, J. G., Gerald, W. L., Lazebnik, Y. A., Cordon-Cardo C., and Lowe, S. W. 2001. Inactivation of the apoptosis effector *Apaf-1* in malignant melanoma. *Nature* **409**: 207-211.
DOI: 10.1038/35051606

Sparg, S. G., Light, M. E., and van Staden, J. 2004. Biological activities and distribution of plant saponins. *Journal of Ethnopharmacology* **94**(1-2): 219-243.
DOI: 10.1016/j.jep.2004.05.016

Susumu, M., Takayuki, M., Yoshinobu, K. 1993. Production of fomable fancy drink. Patent. Applicant: Godo Shusei KK. European application number: JP19910297803 19911018

The Noxious Weeds Designation Regulations, 1999. Chapter N-9.1 Reg.2. The Noxious Weeds Act, 1984. Regina, Saskatchewan.
<http://www/qp.gov.sk.ca/documents/English/Regulations/Regulations/N9-1R2.pdf>

- Tungteakkhun, S. S. and Duerksen-Hughes, P. J. 2008. Cellular binding partners of the human papillomavirus E6 protein. *Archives of Virology* **153**(3): 397-408.
DOI: 10.1007/s00705-007-0022-5
- United States Department of Agriculture (USDA). Agricultural Research Service (ARS), Beltsville Area. Germplasm Resources Information Network (GRIN). 1994. *Saponaria officinalis* L.
<http://www.ars-grin.gov/cgi-bin/npgs/html/taxon.pl?33108>
- Voutquenne, L., Lavaud, C., Massiot, G., and Le Men-Olivier, L. 2002. Structure-activity relationships of haemolytic saponins. *Pharmaceutical Biology* **40**(4): 253-262.
DOI: 10.1076/phbi.40.4.253.8470
- Washington: U.S. Dept. of Health, Education and Welfare. 1974. A Barefoot Doctor's Manual. Leavitt, M. D. (Ed.). Reprint by Fogarty, J. E. (1990). A Barefoot Doctor's Manual: The American Translation of the Official Chinese Paramedical Manual. Runing Press (Pub.)
ISBN-10: 089471810X
- Wen, Y., Chen, Y., Cui, Z., Li, J., and Wang, Z. 1995. Triterpenoid glycosides from the fruits of *Kochia scoparia*. *Planta Medica* **61**: 450-452.
DOI: 10.1055/s-2006-958134
- Xia, Z-H., Zou, M-L., Sang, S-M., and Lao, A-N. 2004. Segetoside L, a new triterpenoid saponin from *Vaccaria segetalis*. *Chinese Chemical Letters* **15**(1): 55-57.
Cited in SCOPUS database.
- Yanamandra, N., Berhow, M. A., Konduri, S., Dinh, D. H., Olivero, W. C., Nicolson, G. L., and Rao, J. S. 2003. Triterpenoids from *Glycine max* decrease invasiveness

and induce caspase-mediated cell death in human SNB19 glioma cells. *Clinical and Experimental Metastasis* **20**(4): 375-383

DOI: 10.1023/A:1024043104803

Yoshiaki, C. And Mitsuru, W. 1992. Production of emulsion composition for food and drink. Patent. Applicant: Hasegawa T. Co. Ltd. European Application Number: JP19900154044 19900614.

Yoshiki, Y., Kudou, S., and Okubo, K. 1998. Relationship between chemical structures and biological activities of triterpenoid saponins from soybean (Review). *Bioscience, Biotechnology and Biochemistry* **59**: 1556-1557.

DOI: 10.1271/bbb.62.2291 PMID: 9972256

Yu, L., Ma, R., Wang, Y., Nishino, H., Takayasu, J., He, W., Chang, M., Zhen, J., Liu, W., and Fan, S. 2006. Potent anti-tumorigenic effect of tubeimoside 1 isolated from the bulb of *Bolbostemma paniculatum* (maxim) franquet. *International Journal of Cancer* **50**(4): 635-638.

DOI: 10.1002/ijc.2910500425

Yue. P. Y. K., Mak, N. K., Cheng, Y. K., Leung, K. W., Ng, T. B., Fan, D. T. P., Yeung, H. W., and Wong, R. N. S. 2007. Pharmacogenomics and the Yin/Yang actions of ginseng: anti-tumor, angiomodulating and steroid-like activities of ginsenosides. *Chinese Medicine* **2**(6): 1-21.

DOI: 10.1186/1749-8546-2-6.

Yui, S., Ubukata, K., Hodono, K., Kitahara, M., Mimaki, Y., Kuroda, M., Sashida, Y., and Yamazaki, M. 2001. Macrophage-oriented cytotoxic activity of novel triterpene saponins extracted from roots of *Securidaca inappendiculata*. *International Immunopharmacology* **1**: 1989-2000.

DOI: 10.1016/S1567-5769(01)00126-6

- Yun, Y-S., Shimizu, K., Morita, H., Takeya, K., Itokawa, H., and Shirota, O. 1998. Triterpenoid saponins from *Saponaria vaccaria*. *Phytochemistry* **47**(1): 143-144. DOI: 10.1016/S0031-9422(97)00496-2 PMID: 9429321
- Yun, Y-S., Morita, H., Takeya, K., and Itokawa, H. 1997. Cyclic peptides from higher plants. 34. Segetalins G and H, structures and estrogen-like activity of cyclic pentapeptides from *Vaccaria segetalis*. *Journal of Natural Products* **60**: 216-218. DOI: 10.1021/np960617n
- Wajant, H. 2002. The Fas signalling pathway: more than a paradigm. *Science* **296**(5573): 1635-1636. DOI: 10.1126/science.1071553
- Wang, Z., Zhou, J., Zhang, H., Liu, M., and Li, X. 2001. Effects of two saponins extracted from the *Polygonatum zanlanscianense* Pamp on the human leukemia (HL-60) cells. *Biological and Pharmaceutical Bulletin* **24**: 159-162. DOI: 10.1248/bbb.24.159
- Watson, L. And Dallwitz, M. J. 1992 onwards. The families of flowering plants: descriptions, illustrations, identification, and information retrieval. Version: 1st June, 2007. <http://delta-intkey.com>
- Wong, M. M. Y. 1986. Inhibitory effect of penfluridol and verapamil in combination with fluorodeoxyuridine on growth of human colon cancer cell lines. M.Sc. Thesis, University of Saskatchewan.
- Wyllie, A. H. 1997. Apoptosis: an overview. *British Medical Bulletin* **53**(3): 451-465. ISSN 0007-1420 PMID: 9374030
- Zhang, A., Wu, Y., Lai, H. W. L., and Yew, D. T. 2004/2005. Apoptosis – A brief review. *Neuroembryology* **3**: 47-59.

DOI: 10.1159/000085404

Zimmermann, K. C. and Green, D. R. 2001. How cells die: apoptosis pathways. *Journal of allergy and clinical immunology* **108**(4 Suppl.): S99-103.

DOI: 10.1067/mai.2001.117819 PMID: 11586274

APPENDIX 1

The following manuscript was published in *Phytochemical Analysis* by Wiley InterScience (www.interscience.wiley.com) in October 2006. The bibliographic reference for the published article is:

J. John Balsevich, Greg G. Bishop, Irving Ramirez-Erosa. 2006. Analysis of bisdesmosidic saponins in *Saponaria vaccaria* L. by HPLC-PDA-MS: identification of new quillaic acid and gypsogenin 3-*O*-Trisaccharides. *Phytochemical Analysis* **17**: 414-423; doi: 10.1002/pca.943

ABSTRACT

A high-performance liquid chromatographic method using photodiode array and single quadrupole electrospray mass detection for analysis and profiling of bisdesmosidic saponins in *Saponaria vaccaria* seed was developed. Profiles of seed extract from three different plant sources were obtained and found to contain the same saponins, albeit in different proportions. Several known saponins were identified by selected ion extraction of quasi-molecular ions from the total ion chromatogram and confirmed by their mass spectra. Application of high cone voltages afforded mass spectra containing key diagnostic fragments and relatively strong singly charged quasi-molecular ions. In addition to previously identified saponins, several new quillaic acid and gypsogenin bisdesmosides could be detected via mass spectral analysis. Five of these were tentatively identified as pentose homologues of known saponins, having an added xylosyl residue linked to the 3-*O*-glucuronyl group (1 →3). The stereochemistry and identity of the xylosyl linkage in the new saponins was determined by chemical means. Previously reported vaccaric or segetalic acid-type bisdesmosides could not be detected in any of the extracts. Copyright © 2006 John Wiley & Sons, Ltd.

Analysis of Bisdesmosidic Saponins in *Saponaria vaccaria* L. by HPLC-PAD-MS: Identification of New Quillaic Acid and Gypsogenin 3-O-Trisaccharides[†]

J. JOHN BALSEVICH,* GREG G. BISHOP and IRVING RAMIREZ-EROSA

Plant Biotechnology Institute, National Research Council of Canada, 110 Gymnasium Place, Saskatoon, Saskatchewan, Canada S7N 0W9

Received 10 March 2006; Revised 24 July 2006; Accepted 24 July 2006

Abstract: A high-performance liquid chromatographic method using photodiode array and single quadrupole electrospray mass detection for analysis and profiling of bisdesmosidic saponins in *Saponaria vaccaria* seed was developed. Profiles of seed extract from three different plant sources were obtained and found to contain the same saponins, albeit in different proportions. Several known saponins were identified by selected ion extraction of quasi-molecular ions from the total ion chromatograms and confirmed by their mass spectra. Application of high cone voltages afforded mass spectra containing key diagnostic fragments and relatively strong singly charged quasi-molecular ions. In addition to previously identified saponins, several new quillaic acid and gypsogenin bisdesmosides could be detected via mass spectral analysis. Five of these were tentatively identified as pentose homologues of known saponins, having an added xylosyl residue linked to the 3-O-glucuronyl group (1 → 3). The stereochemistry and identity of the xylosyl linkage in the new saponins was determined by chemical means. Previously reported vaccaric or segetalic acid-type bisdesmosides could not be detected in any of the extracts. Copyright © 2006 John Wiley & Sons, Ltd.

Keywords: HPLC; electrospray mass spectrometry; saponins; *Saponaria vaccaria*.

INTRODUCTION

The plant *Saponaria vaccaria* L. (Caryophyllaceae)^{††} is widely distributed throughout Eurasia, where it is a native species, and North America, where it is an introduced species (Frankton and Mulligan, 1987). Several accessions of *S. vaccaria* have previously been investigated as a potential new crop for the northern great plains region, owing mainly to the excellent agronomic characteristics of this species and the high content of a unique, small-grained starch (Goering and Brelsford, 1966; Goering *et al.*, 1966; Mazza *et al.*, 1992; Biliaderis *et al.*, 1993). In addition to its attractive agronomic characteristics, the plant also possesses interesting medicinal properties—the seed is used in traditional Chinese medicine (Wang-Bu-Liu-Xing) as a galactagogue and treatment for amenorrhoea and breast infections (Huang, 1994; Sang *et al.*, 2003a). Accordingly, there have been at least two reviews on the phytochemistry of the seed, which is particularly rich in triterpene saponins as well as containing significant amounts of small ($n = 5-9$) cyclic peptides (cyclopeptides) and C-glycosylflavonoids (Jia *et al.*,

2002; Sang *et al.*, 2003b). The triterpene saponins previously identified included a large number of both mono- and bisdesmosides, with the latter, the predominant components, all having been characterised as saponin C-3-O-disaccharide, C-28-O-sugar esters, i.e. 3-O- β -D-Galp-(1 → 2)- β -D-GlcpA, 28-O- β -D-Xylp-(1 → 4)- α -L-Rhap-(1 → 2)-[α -L-Araf-(1 → 3)]- β -D-4-O-acetylFucp derivatives of gypsogenin, and quillaic, vaccaric and segetalic acids, often having further acetyl substitution in the sugar ester side chain (e.g. structures 1–5).

Although a large amount of isolation and structure elucidation work has been performed with this plant, little in the way of analytical or profiling work has been carried out. Previously, saponins from a number of other plant species have been analysed using HPLC methods, which, particularly when coupled to a mass spectrometer, have proven useful in identifying and analysing saponin containing extracts (Hostettmann and Marston, 1995; Lee *et al.*, 1999; Perret *et al.*, 1999; Sturm and Stuppner, 2000; Berhow *et al.*, 2002).

We were interested in screening plants of this species for specific 'chemotypes' which, it was felt, might be useful as sources of medicinal and/or industrial agents. In order to compare various accessions, a convenient method for identifying and profiling some of the main components was developed. This paper describes an HPLC method that makes use of a benchtop single quadrupole mass spectrometer employing negative ion electrospray ionisation (ESI⁻) and a photodiode array detector (PAD), for investigating

* Correspondence to: J. J. Balsevich, Plant Biotechnology Institute, National Research Council of Canada, 110 Gymnasium Place, Saskatoon, Saskatchewan, Canada S7N 0W9.

E-mail: john.balsevich@nrc-cnrc.gc.ca

† NRCC No. 48025.

†† Syn. *Vaccaria segetalis*, *v. hispanica*, *v. pyramidata*. Common name: cow cockle or cow herb.

and identifying bisdesmosidic saponins in *Saponaria* seed. The described method has been used to profile these compounds in extracts derived from three plant sources: a local wild-type accession, a horticultural variety and a commercial herbal product.

EXPERIMENTAL SECTION

General

Solid-phase extraction was carried out with Waters Sep-Pak Vac t-C₁₈ SPE cartridges (Milford, MA, USA). Analytical TLC was performed with Macherey-Nagel (Easton, PA, USA) pre-coated Alugram SIL G/UV₂₅₄ (0.2 mm layer thickness). Preparative TLC was performed on Sigma-Aldrich (St Louis, MO, USA) glass plates (20 × 20 cm; 0.25 mm). Distilled de-ionised water was used for analytical applications.

Plant material and saponin extracts

Seed of *S. vaccaria* 'Scott WT' was obtained from Eric Johnson, Agri-Food and Agriculture Canada, Scott Experimental Farm, Scott, Saskatchewan. Seed of *S. vaccaria* cv. 'Pink Beauty' was obtained from CN Seeds Ltd, Pymoor, UK. The herbal extract, Wang-Bu-Liu-Xing, was purchased from a mail order supplier, Botanicum Herbs (botanium.com). *Quillaja* saponin (S4521), having sapogenin content of approximately 25% (<10% ash), was purchased from Sigma.

HPLC-MS-PAD analysis

A Waters Alliance 2695 chromatography system with inline degasser, coupled to a ZQ 2000 mass detector and a 2996 PAD, was used for analyses. Waters MassLynx v. 4.0 software was used for data acquisition and manipulation. The columns used were a Waters Symmetry RP C₁₈ (150 × 2.1 mm i.d.; 3.5 μm), a Waters Sunfire RP C₁₈ (150 × 2.1 mm i.d.; 3.5 μm) or a Phenomenex (Torrance, CA, USA) Synergi MAX-RP 80A C₁₂ (250 × 2.0 mm i.d.; 4 μm). The flow rate with the Waters columns was 0.2 mL/min, and with the Phenomenex column 0.15 mL/min. Columns were maintained at 35°C during runs. The binary solvent systems used were with solvent A, 0.12% acetic acid in 10% acetonitrile (aq., v/v), and solvent B, 0.12% acetic acid in 100% acetonitrile. Gradients used were: (1) 0–3 min, 75% A–25% B; 3–25 min, 75% A–25% B to 50% A–50% B; 25–28 min, 25% A–75% B to 100% B; 28–33 min, 100% B; and (2) 0–8 min, 90% A–10% B; 8–31 min, 90% A–10% B to 50% A–50% B; 31–33 min, 50% A–50% B to 100% B; 33–48 min, 100% B. Injection volumes of 5 μL were typical.

Unless otherwise noted, the mass detector parameters (ESI⁺) were set to capillary (kV) 2.70, cone (V) –30 to –90.0 over a mass range of 400–1900, extractor (V) –3.50 and RF lens (V) –0.7. PAD was performed over the range 200–400 nm, and saponins were monitored at 209 nm.

Extraction and fractionation

For HPLC-PAD-MS analysis. Seed (50 mg) was crushed and extracted with 70% methanol (2 mL) by mixing and standing at ambient temperature for 2 h. The mixture was centrifuged (microfuge) and the supernatant filtered through a 0.45 μm nylon filter into a sample tube.

For isolation of wild-type saponins. Wild-type seed (10 g) was ground and de-fatted with hexane. The de-fatted meal was extracted with 70% methanol (60 mL) by stirring at ambient temperature for 20 h. The meal was separated by centrifugation and extracted a second time with 70% methanol (25 mL) for 4 h. The combined methanolic extract was concentrated *in vacuo* to afford an amber solid (0.7 g), which was dissolved in water and applied to a conditioned and equilibrated 10 mL SPE cartridge and eluted sequentially with 20–40 mL portions of water, 30–60% methanol and 70–100% methanol. Saponins were obtained in the 70–100% fractions, which were combined and concentrated *in vacuo* to afford a white powder (230 mg).

Saponification, isolation and comparison of prosapogenins

S. vaccaria or *Quillaja* saponins (100–200 mg) were dissolved in 1 M sodium hydroxide (5 mL) and stirred under a nitrogen atmosphere for 3 days at ambient temperature or heated at 80°C for 4 h. The solution was carefully neutralised with 1 M hydrochloric acid, acidified with a small amount of citric acid (ca. 50 mg) and applied to a 5 mL SPE cartridge and sequentially eluted with water and 3, 70 and 100% methanol. The prosapogenins were obtained in the 70–100% fractions. Prosapogenins from both samples were run on Phenomenex and Sunfire columns using both gradients, as outlined above. In addition, 1:1, 2:1 and 3:1 mixtures of the prosapogenins were run using selected ion monitoring at *m/z* 955 to establish that the prosapogenin **13** derived from *Quillaja* saponins was the same as that derived from *S. vaccaria* saponins. Selected ion monitoring at *m/z* 823 also indicated that both reaction mixtures also contained the same 3-*O*-β-disaccharide [3-*O*-β-D-Galp-(1 → 2)-β-D-GlcpA quillaic acid]. The 3-*O*-disaccharide was a minor component in

the *Quillaja*-derived prosapogenin mixture (estimated to account for ca. <20% of prosapogenins), but a significant component in the *S. vaccaria*-derived prosapogenin mixture (estimated to account for ca. 40–50% of prosapogenins).

Dimethyl ester of 3-O- β -D-Xylp-(1 \rightarrow 3)-(β -D-Galp-(1 \rightarrow 2))- β -D-GlcPA quillaic acid (12)

The prosapogenin mixtures (ca. 40 mg each) from above were dissolved in methanol (5 mL) and treated with excess diazomethane in ether. Excess diazomethane was destroyed by addition of a few drops of acetic acid and the mixture was concentrated *in vacuo*. The residue was chromatographed on silica gel (PTLC) using ethyl acetate:methanol:water (30:6:1, twice) to afford the same pure trisaccharide dimethyl ester, based on comparison of NMR spectra and TLC and HPLC behaviour. Previously the trisaccharide diacid from *Quillaja* saponins had been isolated and fully characterised as such (Guo *et al.*, 1998). The published ^1H - and ^{13}C -NMR spectra of the diacid were obtained in methanol- d_4 . The C-28 methyl ester had also previously been identified as a natural product in *Gypsophila oldhamiana* and its ^1H - and ^{13}C -NMR spectra (pyridine- d_5) reported (Liu *et al.*, 1995). We include here our partial ^1H - and ^{13}C -NMR data (1-D) of the dimethyl ester obtained in pyridine- d_5 on a Bruker (Milton, ON, Canada) AMX 500 MHz instrument.

Dimethyl ester 12. ^1H -NMR δ : 9.93 (1H, s, H-23), 5.55 (1H, d, 7.8, H-1 galactose), 5.50 (1H, bs, H-12), 5.29 (1H, d, 7.7, H-1 xylose), 4.89 (1H, d, 7.4, H-1 glucuronic acid), 3.74 (3H, s, OCH₃), 3.68 (3H, s, OCH₃), 3.37 (1H, dd, 14.3&3.5), 2.75 (1H, t, 13.5), 2.44 (1H, dt, 12.7&4), 2.21 (1H, bd, 13.7), 1.73 (3H, s), 1.45 (3H, s), 1.09 (3H, s), 1.02 (3H, s), 0.84 (3H, s), 0.81 (3H, s); ^{13}C -NMR δ : 210.2 (C-23), 178.0 (C-28), 170.2 (C-6 glucuronic acid), 144.9 (C-13), 122.7 (C-12), 105.3 (C-1 xylose), 104.7 (C-1 galactose), 104.2 (C-1 glucuronic acid), 86.0, 84.8, 78.9, 77.1, 76.7, 75.8, 75.6, 74.6, 74.0, 71.3, 71.1, 70.5, 67.7 (C-5 xylose), 62.1 (C-6 galactose), 55.4, 52.5, 52.1, 49.3, 49.0, 47.3, 42.2, 41.6, 40.3, 38.4, 36.5, 36.2, 33.5, 32.9, 32.8, 31.2, 27.4, 25.5, 24.9, 24.0, 20.8, 17.5, 16.0, 11.4.

RESULTS AND DISCUSSION

HPLC-PAD and MS analyses

HPLC analysis of aqueous methanolic seed extracts, using an acidified acetonitrile–water gradient (1; see Experimental section) and a reverse-phase column with PAD detection, afforded the profiles shown in Fig. 1. The extracts were prepared with minimal

processing in order to obtain as true a profile as possible. The main bisdesmosidic saponins (Fig. 2) could be separated from most of the other soluble products (carbohydrates, phenolics, cyclic peptides and monodesmosides) present in the crude seed extract, and were readily detected at 209 nm, eluting between 10 and 25 min in the system employed. Polysaccharides, phenolics and cyclopeptides eluted earlier than the saponins and could be easily distinguished via PAD at appropriate wavelengths and/or the corresponding MS (data not shown). Also tending to elute earlier were the lower molecular weight monodesmosidic saponins (molecular weights <1300), which were relatively minor but still significant components in the mixture.

The bisdesmosidic saponin profile of the wild-type seed was complex, with more than 20 saponins estimated (based on both UV, see Fig. 1, and mass detection, see Fig. 3 and Table 1) as being present in the mixture. From scrutiny of previously published structures and the quasi-molecular ions exhibited in the total ion chromatogram (TIC) (Fig. 3), it appeared that a majority of bisdesmosides observed here had not previously been identified (Table 1). Examination of chromatograms (UV and mass detection) derived from a commercial herbal product and a horticultural variety, cv. 'Pink Beauty', indicated that the same saponins observed in the wild-type seed extract were also present in their extracts, but in substantially different proportions (Fig. 1). Since the bisdesmosides all contained the same chromophore (an isolated double bond) and there did not appear to be other significant UV-absorbing chromophores in this region, the obtained profiles reflected the relative molar proportions of the various components making up the peaks. In the herbal product (Fig. 1), the main bisdesmoside was observed to be the known compound, vaccaroside E (**1**, ca. 13.45 min, MW 1422.6), whereas in the wild-type and 'Pink Beauty' accessions, a higher proportion of the acetylated analogue, segetoside I (**2**, ca. 18.2 min, MW 1464.6) was noted. In addition, the herbal product appeared to have lower relative amounts of the later eluting saponins and greater relative amounts of the earlier eluting saponins. The assignment of peaks to the above known saponins was based on extracting selected mass chromatograms from the TIC, using their molecular weights as the selection criterion. In this manner, it was possible to confirm the presence of known principal saponins **1–5** and identify their elution times, as shown in Fig. 4. Furthermore, a similar process could be used to identify the elution times of the other saponins noted in the scan of quasi-molecular ions exhibited in Fig. 3. A list of bisdesmosides identified and their retention times (from the same run) based on their observed quasi-molecular ions is shown in Table 1.

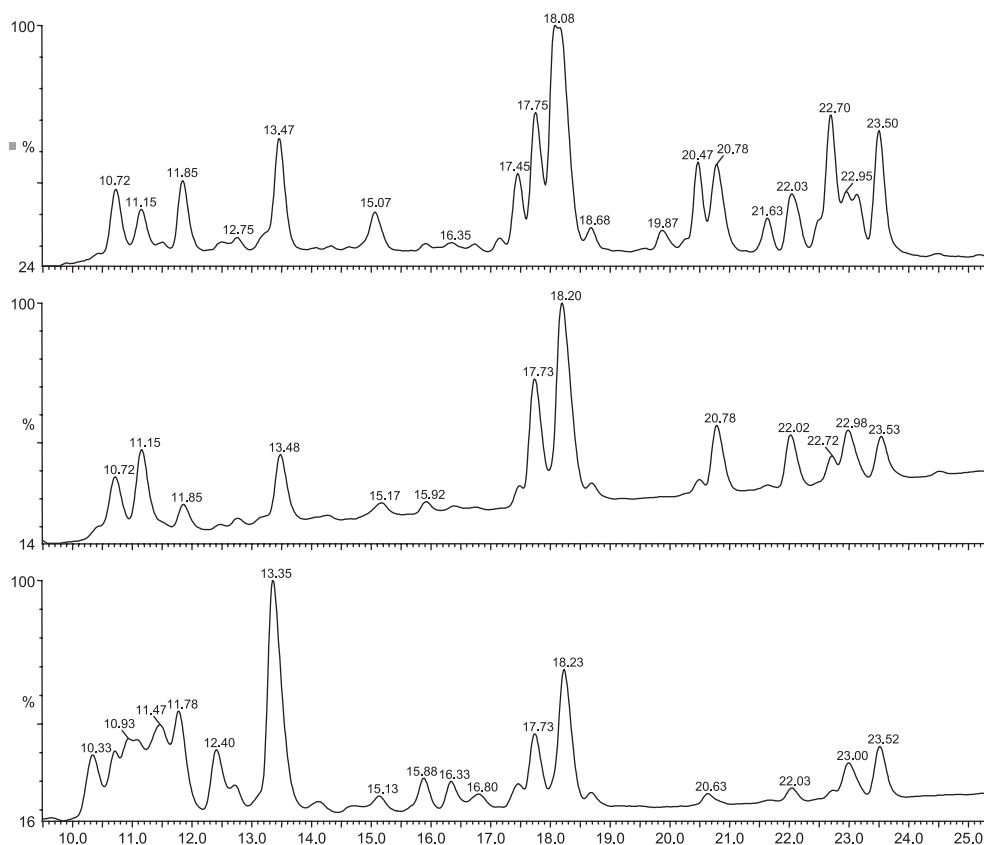

Figure 1 HPLC chromatograms, 10–25 min region, of seed saponins from an *S. vaccaria* wild-type accession (top), horticultural cultivar 'Pink Beauty' (middle), and a commercial herbal product, Wang-Bu-Liu-Xing (bottom). Chromatographic conditions: Symmetry C_{18} column, gradient 1 elution (see Experimental section), UV detection at 209 nm.

Identification of novel 3-*O*-trisaccharide saponins by MS

During the course of examining the TICs, it was observed that peaks due to known bisdesmosides **1–5** were associated with closely eluting or overlapping peaks of unknown saponins that exhibited corresponding quasi-molecular ions 132 mass units higher (Fig. 5). Mass spectra generated by combining MS scans across the appropriate chromatographic peak or portion thereof in the TIC indicated that some key fragments obtained from the new saponins were also 132 mass units higher. Under the conditions employed, the main fragmentation pathway of the bisdesmosidic saponins was observed to be loss of sugars at the sugar ester end (pathway a, Fig. 2), with quillaic acid saponins such as **1–3** giving rise to a fragment ion at m/z 823 and gypsogenin saponins such as **4** and **5** affording the corresponding fragment ion at m/z 807. Cleavage at the 3-*O* glycoside end of the saponins could also be observed at cone voltages >90 V, giving rise to ions representative of the parent aglycones, quillaic acid and gypsogenin (i.e. m/z 485 and 469, pathways a and b, Fig. 2). The closely eluting new saponins, in addition to quasi-molecular ions 132 mass units higher, also exhibited fragments at m/z 955 or 939 (pathway a) and

corresponding aglycone fragments at m/z 485 and 469 (pathways a and b), thus implicating them as added sugar homologues of the known saponins **1–5**, with the added sugar being a pentose at the 3-*O*-glycoside end. The fragmentation and type of ions generated in the extracted MS were strongly dependent on the cone voltage. At higher voltages (>90 V) strong singly charged quasi-molecular ions $[M - H]^-$, fragments due to loss of sugars at the ester end (pathway a, Fig. 2) and ions due to complete loss of sugars (pathways a and b, Fig. 2) were obtained, whereas at 30 V only doubly charged $[M - 2H]^{2-}$ ions were observed. At 60 V ions due to the loss of sugars at the ester end were observed, but not ions due to loss of sugars at the glycosidic end (pathway b, Fig. 2). Figure 6 shows the MS of known compounds vaccaroside E, segetoside H and corresponding new saponins **6** and **10** obtained with a cone voltage of 120 V. The relatively 'clean' MS observed were obtained by using a 'slower' gradient HPLC system (2; see Experimental section), which allowed for better separation of the 3-*O*-trisaccharide derivatives from the corresponding disaccharides. The 3-*O*-trisaccharides were observed to have very similar but earlier elution times than the corresponding disaccharides, as might be expected due to their very similar but somewhat more polar structures (cf. Figs 4 and 5). Extending this

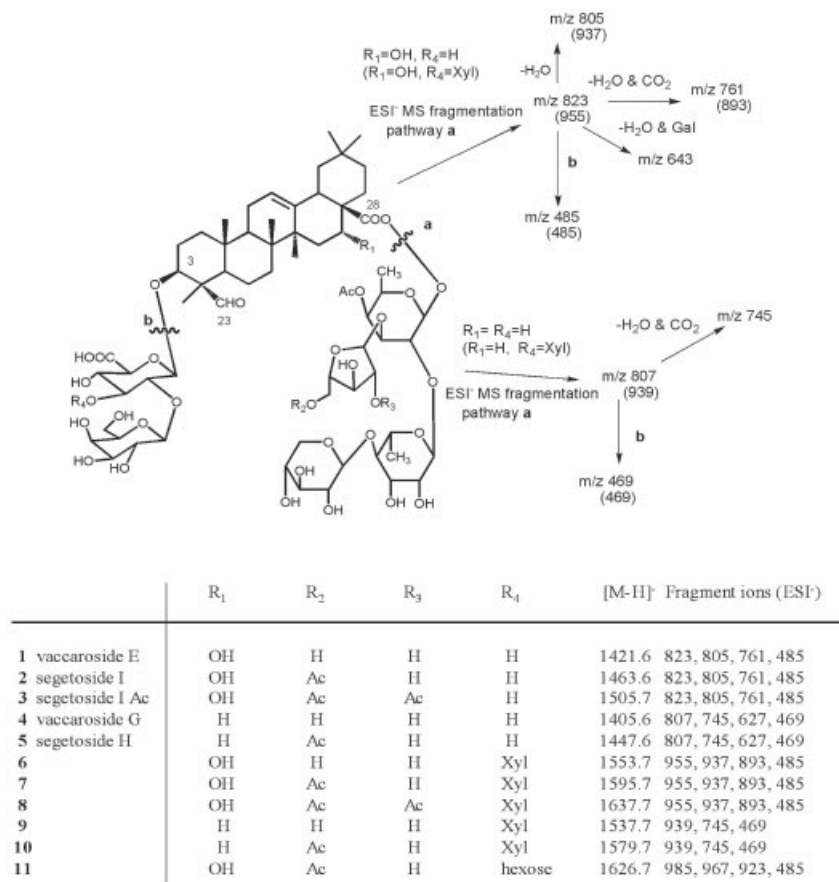

Figure 2 Putative structures, deprotonated molecular $[M - H]^-$ ions, and principal fragments (generated by collision-induced dissociation in the ion source) for the major bisdesmosidic saponins detected in *S. vaccaria* wild-type accession, using negative electrospray ionisation (ESI⁻) mass spectrometry with cone voltages >90 V.

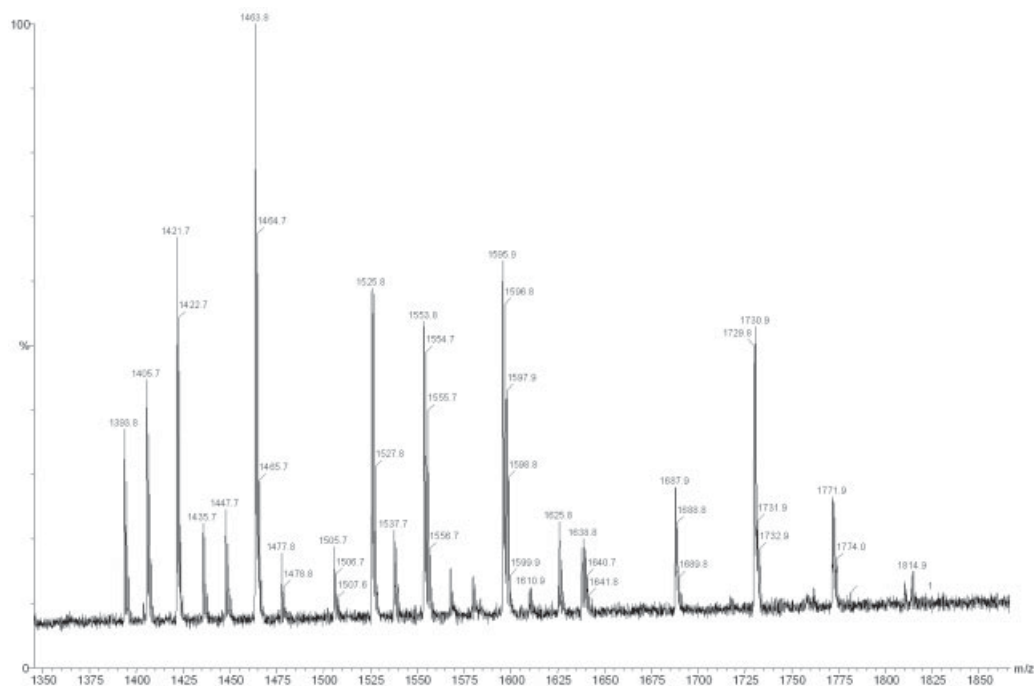

Figure 3 Quasi-molecular ions (m/z 1350–1900) generated from combined scan (ESI⁻) of bisdesmosidic region (10–25 min) of total ion chromatogram derived from wild type *Saponaria* seed extract.

Table 1 Bisdesmosidic saponins observed in a wild type *Saponaria* accession. Retention times were obtained by selected ion extraction from TIC of appropriate quasi-molecular ion. Aglycone type (sapogenin) was determined from combined extracted mass spectrum obtained at a cone voltage of 90 V. Slight differences in retention time on the chromatograms are due to differences in tubing lengths leading to detectors. Disaccharide = 3-O- β -D-Galp-(1 \rightarrow 2)- β -D-GlcpA; trisaccharide = 3-O- β -D-Xylp-(1 \rightarrow 3)-[β -D-Galp-(1 \rightarrow 2)]- β -D-GlcpA.

[M - H] ⁻ m/z	Aglycone	3-O-substituents	Compound	Fragment ions, m/z	R _t (min) (single run)
1394	Quillaic acid	Disaccharide	Unknown	823, 485	10.48
1406	Gypsogenin	Disaccharide	Vaccaroside G (4)	807, 469	17.81
1422	Quillaic acid	Disaccharide	Vaccaroside E (1)	823, 485	13.55
1436	Quillaic acid	Disaccharide	Unknown	823, 485	18.36
1448	Gypsogenin	Disaccharide	Segetoside H (5)	807, 469	22.07
1464	Quillaic acid	Disaccharide	Segetoside I (2)	823, 485	18.36
1478	Quillaic acid	Disaccharide	Unknown	823, 485	23.59
1506	Quillaic acid	Disaccharide	Segetoside I Ac (3)	823, 485	20.87
1526	Quillaic acid	Trisaccharide	Unknown	955, 485	11.27
1538	Gypsogenin	Trisaccharide	New saponin 9	939, 469	17.58
1554	Quillaic acid	Trisaccharide	New saponin 6	955, 485	13.52
1556	Quillaic acid	Disaccharide	Unknown	823, 485	10.60
1568	Quillaic acid	Trisaccharide	Unknown	955, 485	18.23
1580	Gypsogenin	Trisaccharide	New saponin 10	939, 469	21.69
1596	Quillaic acid	Trisaccharide	New saponin 7	955, 485	18.13
1598	Quillaic acid	Disaccharide	Unknown	823, 485	17.91
1610	Quillaic acid	Trisaccharide	Unknown	955, 485	23.27
1626	Quillaic acid	Trisaccharide ^a	New saponin 11	985, 485	17.51
1638	Quillaic acid	Trisaccharide	New saponin 8	955, 485	20.52
1640	Quillaic acid	Disaccharide	Unknown	823, 485	23.06
1688	Quillaic acid	Trisaccharide	Unknown	955, 485	10.69
1730	Quillaic acid	Trisaccharide	Unknown	955, 485	11.91
1730	Quillaic acid	Trisaccharide	Unknown	955, 485	17.76
1772	Quillaic acid	Trisaccharide	Unknown	955, 485	22.75
1814	Quillaic acid	Trisaccharide	Unknown	955, 485	23.53

^a Trisaccharide = glucuronic acid, galactose, hexose (unknown).

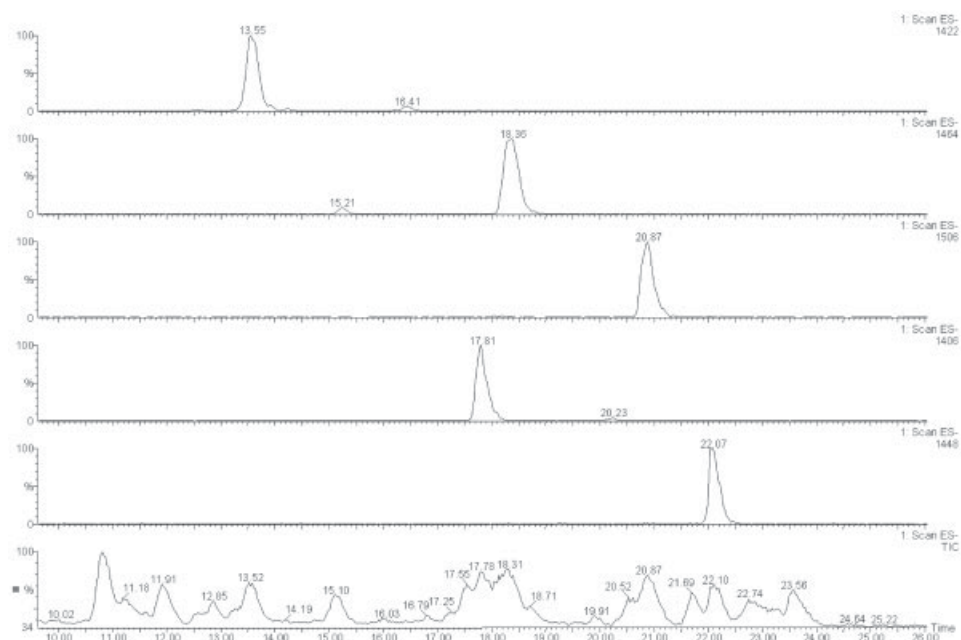

Figure 4 Total and extracted ion HPLC-MS chromatograms for *S. vaccaria* wild-type seed extract (10–25 min region). Extracted ions of *m/z* 1422, 1464, 1506, 1406 and 1448 (top to bottom) correspond to known bisdesmosidic saponins **1–5**, respectively. Slight difference in retention times on the chromatograms are due to differences in tubing lengths leading to detectors.

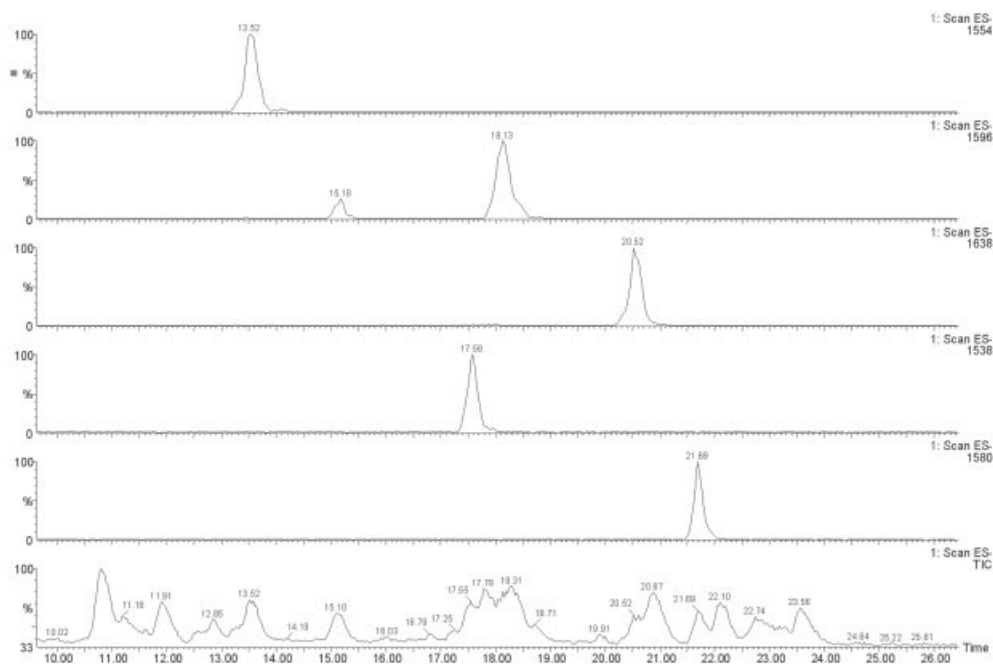

Figure 5 Total and extracted ion HPLC-MS chromatograms for the *S. vaccaria* seed extract. Extracted ions of m/z 1554, 1596, 1638, 1538 and 1580 (top to bottom) correspond to putative new compounds **6–10**, respectively.

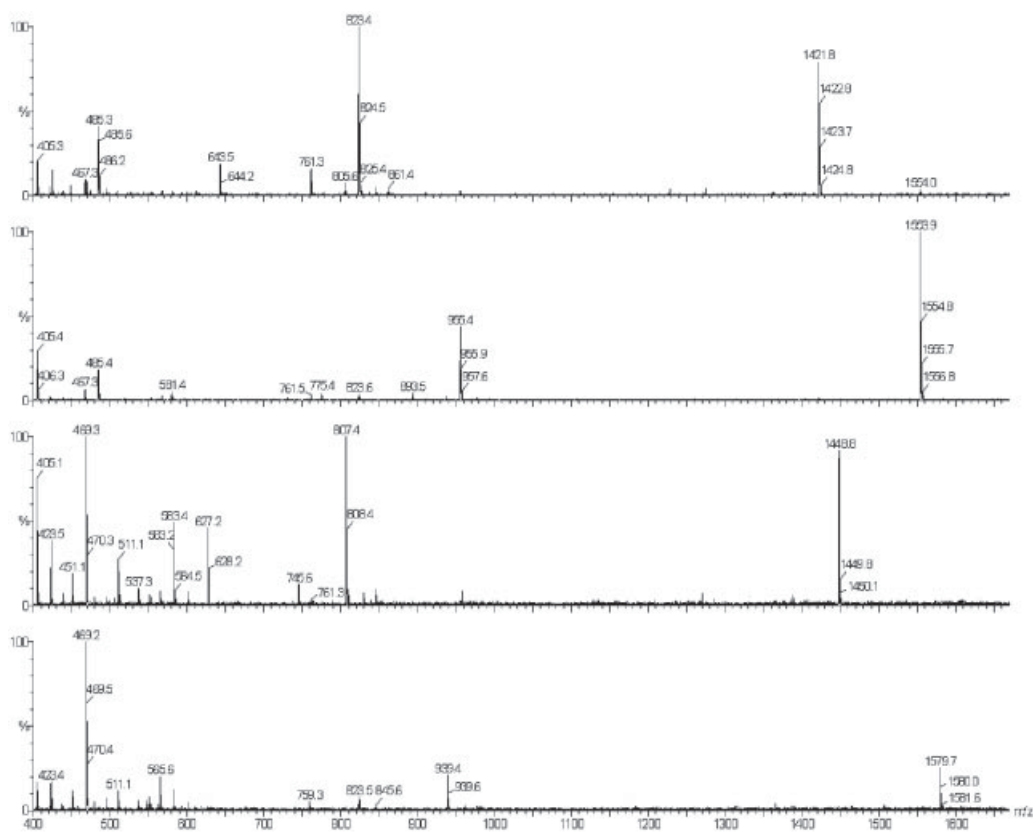

Figure 6 Combined extracted MS obtained from TIC of wild-type seed extract: (a) vaccaroside E (**1**); (b) xylosyl homologue **6**; (c) segetoside H (**5**); (d) xylosyl homologue **10**. Cone voltage was 120 V.

approach, MS were extracted from the various selected ion chromatograms that were obtained on the basis of the quasi-molecular ions observed in Fig. 3. Examination of the resultant MS allowed the new bisdesmosides

to be categorised as to whether they possessed a di- or tri-saccharide linkage at the 3-*O*-position, as well as to which aglycone they were derived from. The overall results are summarised in Table 1.

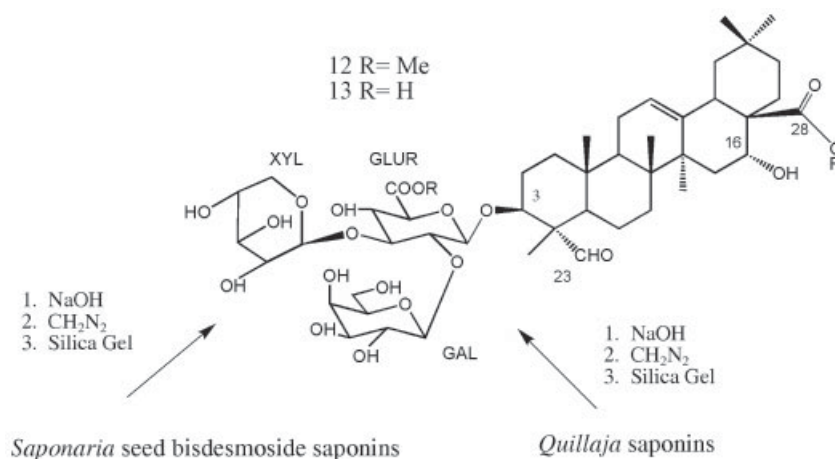

Figure 7 Outline of reactions used to establish identity and location of pentose unit in new *Saponaria* bisdesmosidic saponins.

Chemical identification of the main 3-O-trisaccharide structure

Although the MS data supported the conclusion that new saponins **6–10** were 3-O-trisaccharide analogues of the known 3-O-disaccharides **1–5**, the identity and nature of the linkage of the extra pentose unit was not discernable from this data. In order to determine this, the scheme outlined in Fig. 7 was used. Bisdesmosidic saponins were obtained from wild-type seed extract via processing on a Sep-Pak C₁₈ column and were saponified with sodium hydroxide solution to yield a mixture of prosapogenins (i.e. C-3-O-glycoside, C-28 carboxylic acids). Analysis of the reaction by HPLC-PAD-MS (data not shown) indicated that two main prosapogenins ($[M - H]^-$ at m/z 823 and 955) and several minor prosapogenins ($[M - H]^-$ at m/z 985, 939 and 807) were obtained. The mixture contained approximately equivalent amounts of the 3-O-di- and 3-O-tri-saccharide prosapogenins (m/z 823 and 955), which were estimated to represent close to 90% of the prosapogenin mixture. This mixture was difficult to separate and purify; however, treatment with diazomethane afforded the more easily handled dimethyl esters. Chromatography on silica gel allowed for ready isolation of pure 3-O- β -D-Xylp-(1 \rightarrow 3)-[β -D-Galp-(1 \rightarrow 2)]- β -D-GlcpA quillaic acid dimethyl ester (**12**) identified as such by comparison with the major product obtained from commercial *Quillaja* saponin by the same process (Fig. 7). The prosapogenin diacid (**13**) is the major product obtainable from saponification of *Quillaja* saponins and had previously been identified and fully characterised (Guo *et al.*, 1998). Dimethyl ester (**12**) obtained separately from *Quillaja* and *S. vaccaria* extracts was found to be identical by comparison of ¹H- and ¹³C-NMR, as well by co-chromatography (TLC and HPLC), conclusively establishing the structure of the 3-O-trisaccharide portion of the main *S. vaccaria* bisdesmosides. Although this type of 3-O-trisaccharide

had not been previously reported in this species, it is a common saponin structural type and has been observed in other members of the Caryophyllaceae family (Frechet *et al.*, 1991; Jia *et al.*, 2002; Larshini *et al.*, 2003) as well as being the main type found in commercial *Quillaja* saponin preparations as noted above (Nord and Kenne, 1999). The fact that the complex mixture of *S. vaccaria* bisdesmosides, on saponification, yielded two main prosapogenins meant that much of the structural variation between individual saponins in these extracts was a consequence of differences in the sugar ester portion.

The putative gypsogenin saponins **9** and **10** were overall minor constituents and it was not possible at this time to isolate the analogous dimethyl esters from the saponified methylated reaction mixture produced above to conclusively establish their trisaccharide structures; however, based on the available data, it is reasonable tentatively to assign their structures as being analogous to the quillaic acid derivatives **6** and **7**, analogous to the relationship of known gypsogenin derivatives **4** and **5** with known quillaic acid derivatives **1** and **2**.

All other new bisdesmosides observed in the seed extracts with the exception of one, (**11**, MW 1626) appeared to be quillaic acid derivatives with either a 3-O-di- or tri-saccharide linkage where the trisaccharide consisted of a glucuronic acid substituted with galactose and xylose as noted above. The exception was an unknown saponin with a molecular weight of 1626 whose MS contained fragments at m/z 985 and 485, indicative of a quillaic acid bisdesmoside with a 3-O-trisaccharide unit probably consisting of a glucuronic acid, galactose and a hexose (rather than a xylose). This compound, tentatively assigned as **11**, was believed to be homologous to segetoside I (**2**) and trisaccharide **7**, being a sugar homologue of **2**, having an extra hexose unit at the 3-O-glycoside end and a carbon homologue of **7**, having a hexose rather than a

pentose as part of the 3-*O*-trisaccharide unit. All three of these compounds had similar retention times (Table 1), consistent with a close structural relationship between them.

3-*O*-Trisaccharide profile differences of seed extracts

Examination of the seed extracts obtained from the different plant sources indicated quite a difference in the relative amounts of the 3-*O*-trisaccharides **6–10**. In the herbal extract, they were observed to be relatively minor components (estimated at 0–20% of corresponding disaccharides), whereas in the wild-type seed extract they were quite significant (estimated at ca. 40–110% of corresponding disaccharides). They were also significant in the 'Pink Beauty' extract, but less so than in the wild-type seed extract. The variation in amounts of these 3-*O*-trisaccharide saponins relative to the corresponding 3-*O*-disaccharide analogues could be noted by examining the ratio of quasi-molecular ions generated in the combined extracted spectra of the two homologous components (e.g. Fig. 8) or by examining their chromatograms obtained with PAD detection at 209 nm, using a 'slower' gradient where necessary in order to obtain greater peak separation. For example, segetoside I Ac (**3**) and the corresponding xylosyl homologue **8** could be readily separated even in the 'fast' gradient (1) used to generate chromatograms shown in Fig. 1. The peaks at ca. 20.5 and 20.8 min corresponding to these two compounds (**8** and **3** respectively) had

similar areas in the wild-type extract, indicating similar and significant amounts of both. In the 'Pink Beauty' cultivar there was very little **8** present, while in the herbal extract there was very little **3** and virtually no **8** present.

Search for segetalic or vaccaric acid bisdesmosides

Previously two C-23 nortriterpene saponins, vaccaroside F (aglycone = C-23 norquillaic acid) and H (aglycone = C-23 norgypsogenin), had also been reported from *Saponaria vaccaria* (Jia *et al.*, 1998). A search for these bisdesmosidic saponins was carried out using selected ion examination of the TICs obtained from the studied extracts. Vaccaroside F (MW 1410.6, segetalic acid derivative) and vaccaroside H (MW 1394.6, vaccaric acid derivative), under the described conditions, were expected to yield in addition to strong quasi-molecular ions, key diagnostic fragment ions resulting from loss of sugars (ester end) at *m/z* 811 and 795 as well as ions due to the parent aglycone at *m/z* 473 (segetalic acid) and 457 (vaccaric acid), respectively. Although a significant quasi-molecular ion was observed at *m/z* 1394, the fragment ions observed indicated that it was a quillaic acid 3-*O*-disaccharide (ions at *m/z* 823 and 485) and not the expected vaccaric acid derivative, vaccaroside H (expected ions at *m/z* 795 and 457). Selected ion extraction at *m/z* 1410, 811, 795, 473 or 457 also did not produce any significant peaks in the TIC, indicating that these extracts contained little or none of these types of

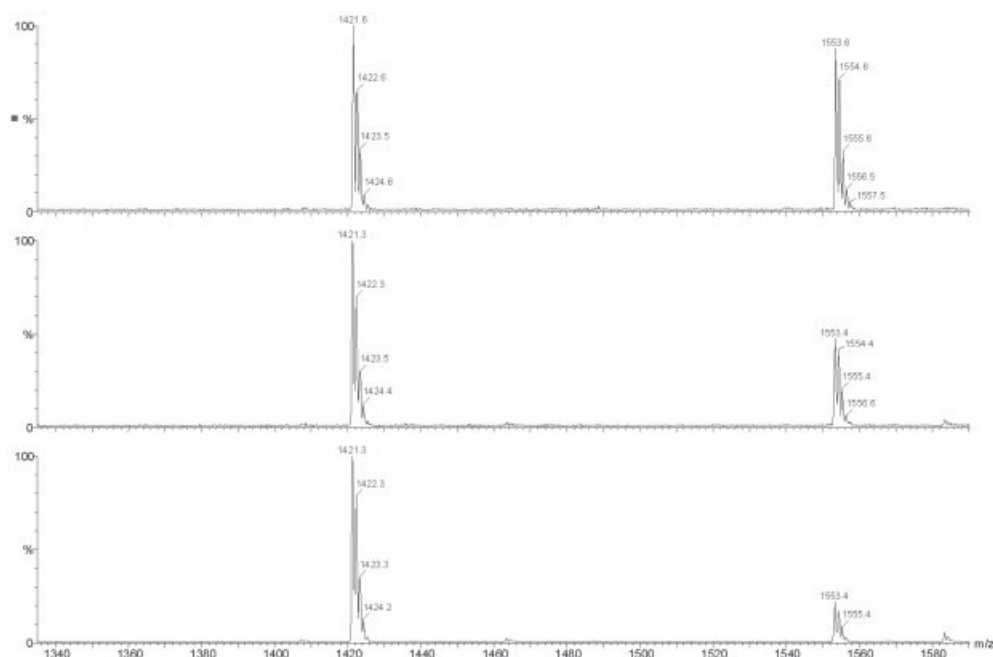

Figure 8 Quasi-molecular ions generated from combined scan of 13–14 min range in TIC of extracts derived from *Saponaria* wild-type seed (top), 'Pink Beauty' seed (middle), and commercial herbal extract (bottom). MW 1422 = vaccaroside E (**1**); MW 1554 = xylosyl homologue **6**.

saponins. The fact that these types of saponins were not observed in any extracts derived from three very different plant sources, which were minimally processed, suggested the possibility that these reported compounds may have been artefacts, produced during the many isolation and purification steps required to obtain purified saponins. Thus, Baeyer–Villiger type oxidation of the C-23 aldehyde group of **1** and **4** during processing of the extracts could lead to formate esters, hydrolysis of which would afford the corresponding C-23 norsaponins vaccaroside F and H. There is precedence for Baeyer–Villiger oxidation of aldehydes yielding formate esters (Corma *et al.*, 2005) and hydrolysis of formate esters is known to be very facile (Lakshmi and Balasubramanian, 2003). We believe this speculation to be quite reasonable, although the alternative possibility, that the C-23 norsaponins previously reported were selectively produced by the particular plant examined, cannot be ruled out at this time.

In conclusion, the methodology described here should be useful for analysis of other similar saponin or glycoside containing extracts.

ACKNOWLEDGEMENTS

We wish to thank Mr. Brock Chatson for providing NMR spectra, Drs. Andrew Ross and Jon Page for help with the manuscript, and Mr. Eric Johnson for providing cow cockle seed. Mr. Ramirez-Erosa gratefully acknowledges support from the Saskatchewan Agriculture Development Fund and the Maunders McNeil Foundation (Calgary).

REFERENCES

- Berhow MA, Cantrell CL, Duval SM, Dobbins TA, Vaughn F. 2002. Analysis and Quantitative determination of group B saponins in processed soybean products. *Phytochem Anal* **13**: 343–348.
- Biliaderis CG, Mazza G, Przybylski R. 1993. Composition and Physicochemical properties of starch from cow cockle (*Saponaria vaccaria* L.) seeds. *Starch/Starke* **45**: 121–127.
- Corma A, Iborra S, Mifsud M, Renz M. 2005. Mesoporous molecular sieve Sn-MCM-41 as Baeyer–Villiger oxidation catalyst for sterically demanding aromatic and α,β -unsaturated aldehydes. *ARKIVOC* **ix**: 124–132.
- Frankton C, Mulligan GA. 1987. *Weeds of Canada* (revision of 1970 edn). Agriculture Canada Publication 948; 217.
- Frechet D, Christ B, Monegier du Sorbier B, Fischer H, Vuilhorgne M. 1991. Four triterpenoid saponins from dried roots of *Gypsophila* species. *Phytochemistry* **30**: 927–931.
- Goering KJ, Brelsford DL. 1966. New starches, I. The unusual starch from *Saponaria vaccaria*. *Cereal Chem.* **43**: 127–135.
- Goering KJ, Eslick RF, Watson CA, Keng J. 1966. Utilization and agronomic studies of cow cockle (*Saponaria vaccaria*). *Econ. Bot.* **20**: 429–433.
- Guo S, Kenne L, Lundgren LN, Ronnberg B, Sundquist BG. 1998. Triterpenoid saponins from *Quillaja saponaria*. *Phytochemistry* **48**: 175–180.
- Hostettmann K, Marston A. 1995. *Saponins*. Cambridge University Press: New York; 128–139.
- Huang KC. 1994. *The Pharmacology of Chinese Herbs*. CRC Press: London, 254.
- Jia Z, Koike K, Kudo M, Li H, Nikaido T. 1998. Triterpenoid saponins and sapogenins from *Vaccaria segetalis*. *Phytochemistry* **48**: 529–536.
- Jia Z, Koike K, Sahu NP, Nikaido T. 2002. Triterpenoid saponins from Caryophyllaceae family. In *Studies in Natural Products Chemistry*, Vol. 26, Rahman A-U (ed.). Elsevier: Amsterdam, 3–61.
- Lakshmi, R and Balasubramanian, KK. 2003. A stereoselective carbohydrate route to optically active furo[2,3-b]benzofuran ring system. *ARKIVOC* **iii**: 140–145.
- Larshini M, Marston K, Hostettmann K. 2003. Triterpenoid saponins from the roots of *Silene cucubalus*. *Fitoterapia* **74**: 237–241.
- Lee M-R, Che C-M, Hwang B-H, Hsu L-M. 1999. Analysis of saponins from black bean by electrospray ionization and fast atom bombardment tandem mass spectrometry. *J Mass Spectrom* **34**: 804–812.
- Liu Z, Li D, Owen NL, Grant RG, Cates RG, Jia Z. 1995. Triterpenoid saponins from *Gypsophyla Oldhamiana*. *J Nat Prod* **58**: 1632–1635.
- Mazza G, Biliaderis CG, Przybylski R, and Oomah BD. 1992. Compositional and morphological characteristics of cow cockle (*Saponaria vaccaria*) seed, a potential alternative crop. *J Agric Food Chem* **40**: 1520–1523.
- Nord LI, Kenne L. 1999. Separation and structural analysis of saponins in a bark extract from *Quillaja saponaria* Molina. *Carbohydr Res* **320**: 70–81.
- Perret C, Wolfender J-L, Hostettmann. 1999. LC/ES-MS Analysis of triterpene glycosides: rapid estimation of the saponin content of dried berries of *Phytolacca dodecandra*. *Phytochem Anal* **10**: 272–278.
- Sang S, La A, Chen Z, Uzawa J, Fujimoto Y. 2003a. Chemistry and bioactivity of seeds of *Vaccaria segetalis*. In *Oriental Foods and Herbs: Chemistry and Health Effects*, Ho CT, Lin JK, Zheng QY (eds). American Chemical Society: Washington, DC, 279–291.
- Sang S, Xia Z, Lao A, Chen Z, Uzawa J, Fujimoto Y. 2003b. Studies on the constituents of the seeds of *Vaccaria segetalis*. *Heterocycles* **59**: 811–821.
- Sturm S, Stuppner H. 2000. Analysis of curcubitacins in medicinal plants by high-pressure liquid chromatography-mass spectrometry. *Phytochem Anal* **11**: 121–127.

APPENDIX 2

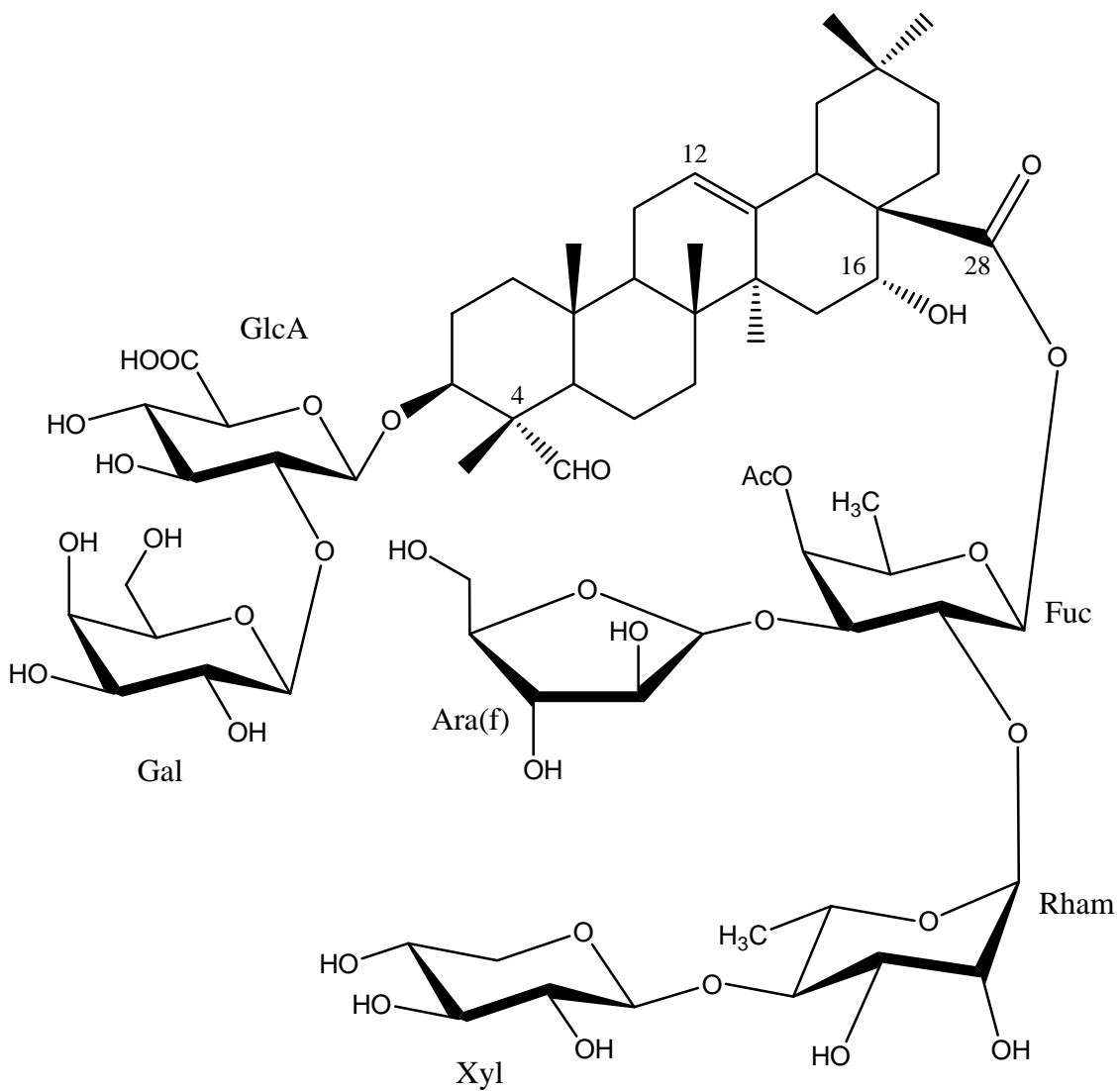

Vaccaroside E
PC 1422

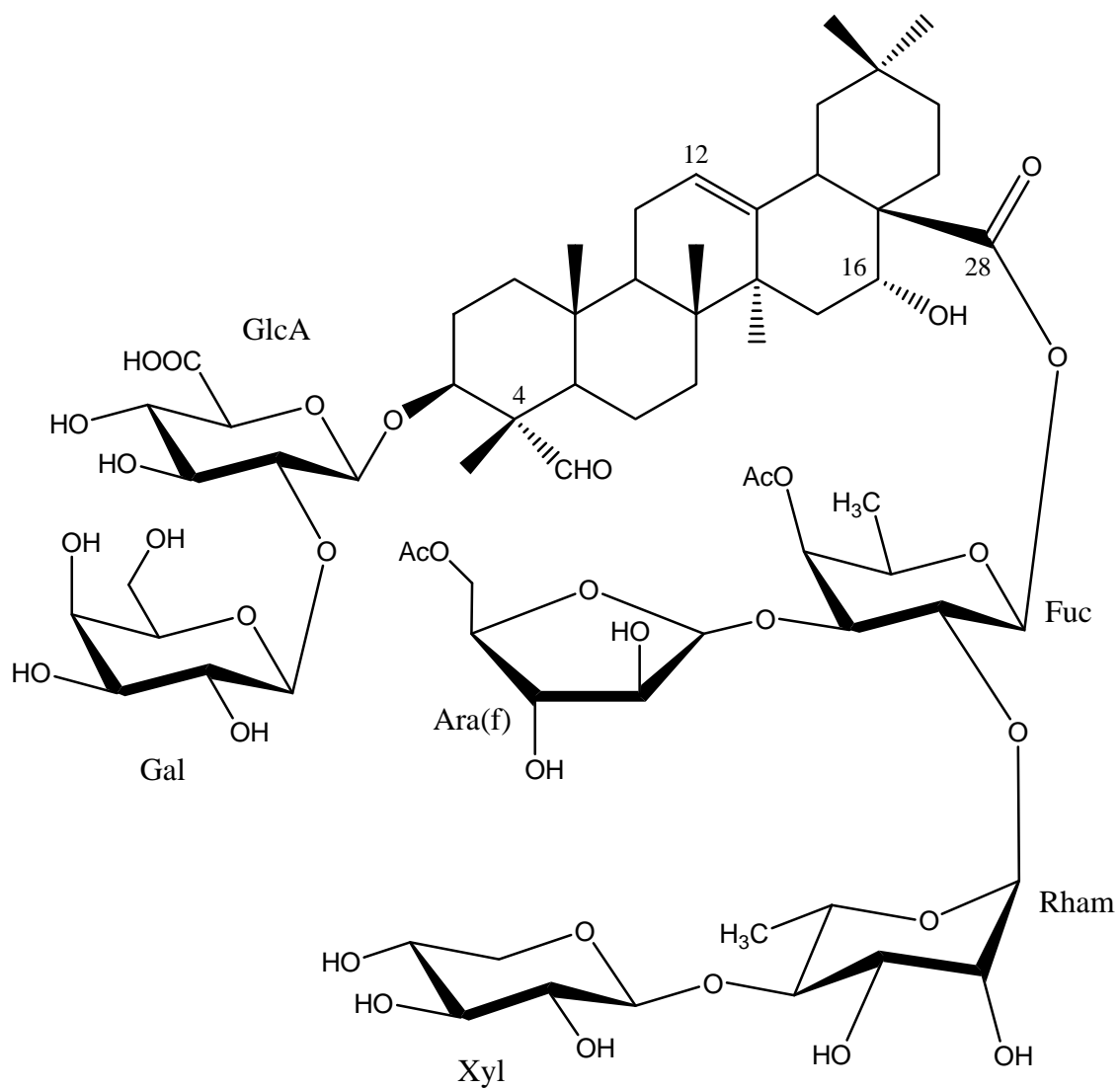

Segetoside I
PC1464

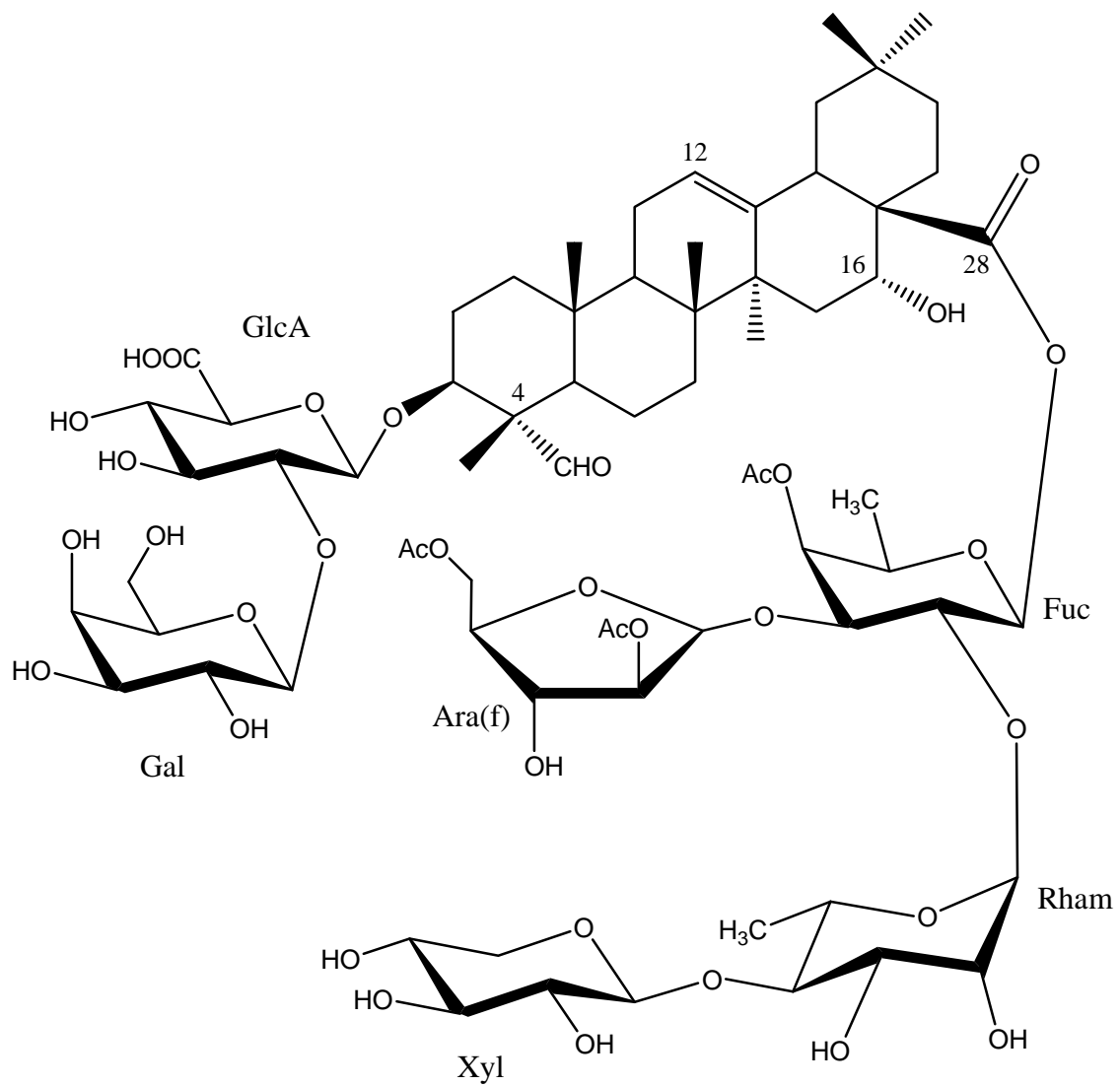

**Segetoside I + Acetate (New saponin)
PC 1506**

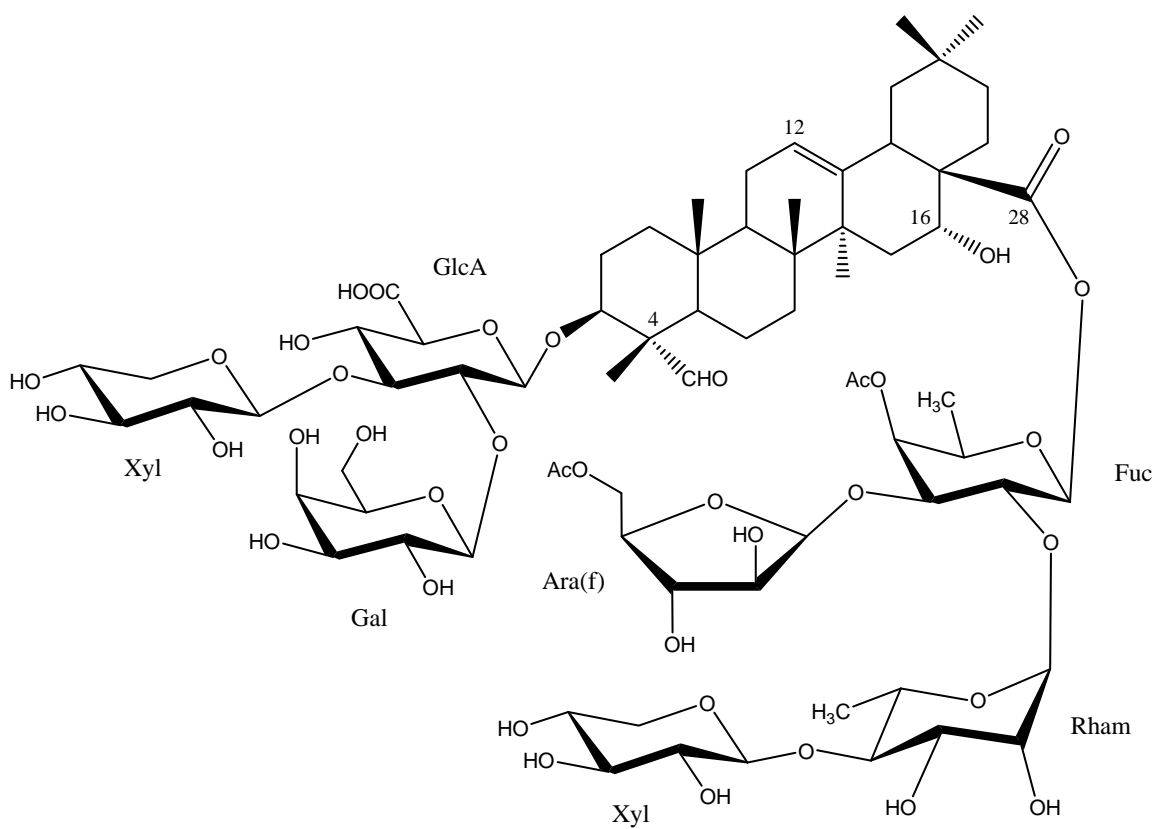

**New saponin
PC 1596**

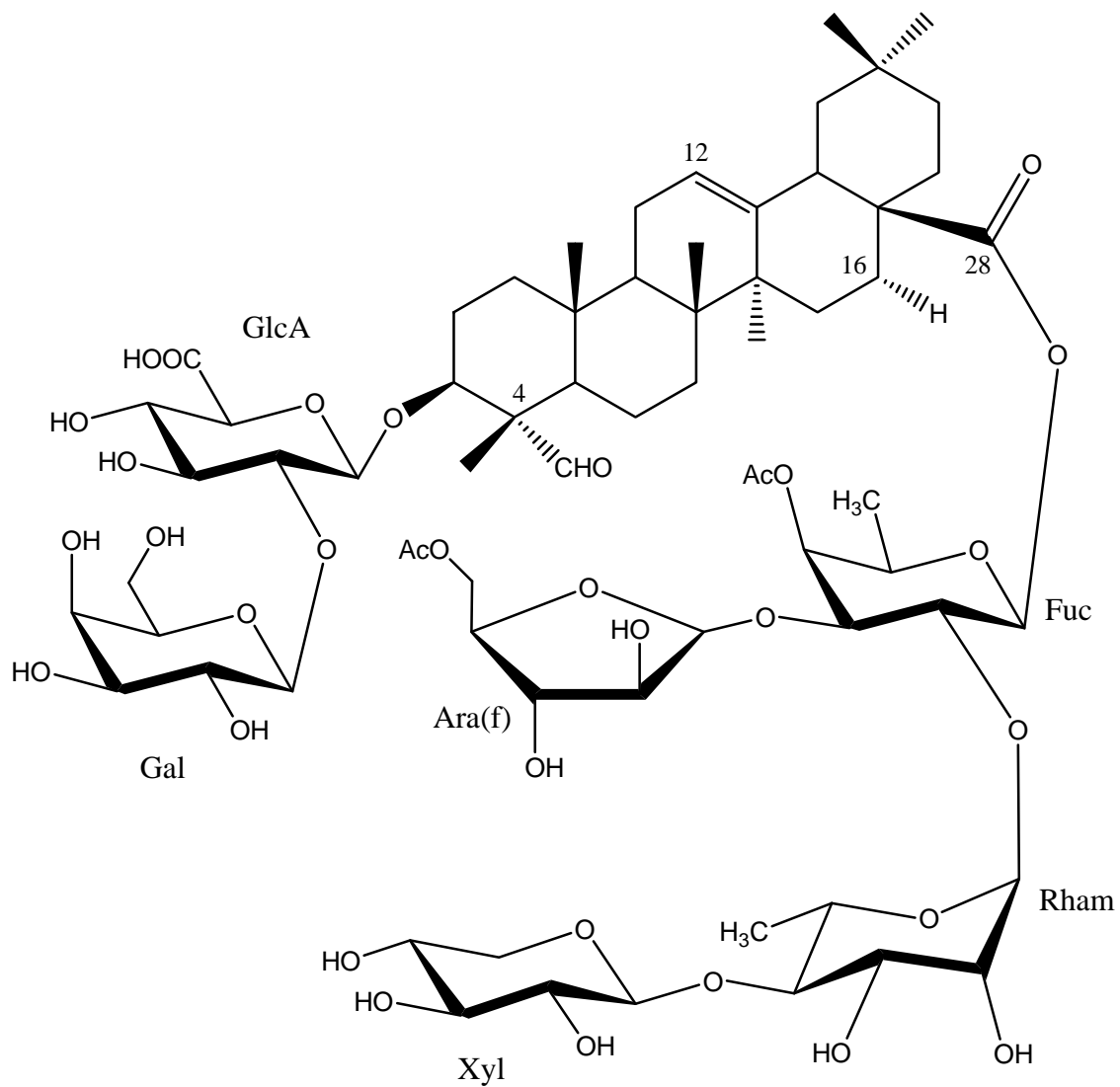

Segetoside H
PC1448

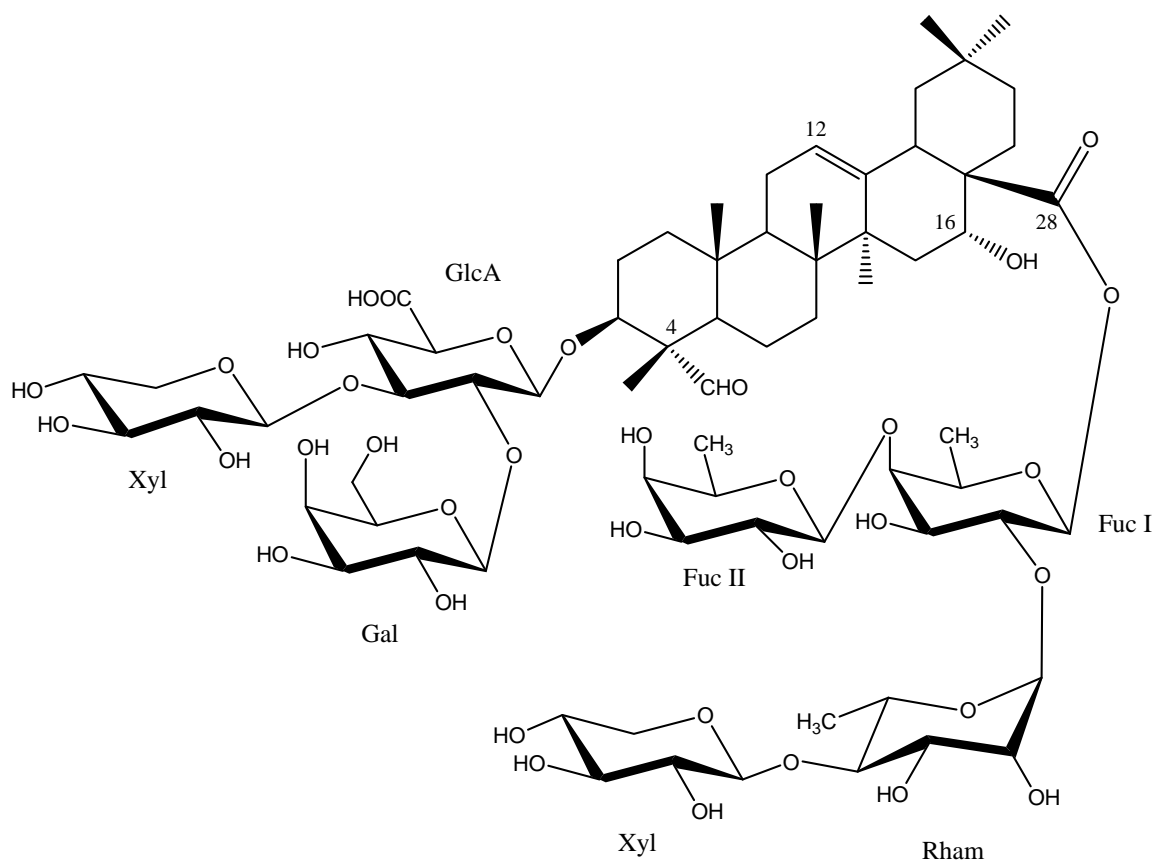

**Vaccaroside JB (New Saponin)
PC 1526**