

UNIVERSITY OF SASKATCHEWAN

This volume is the property of the University of Saskatchewan, and the literary rights of the author and of the University must be respected. If the reader obtains any assistance from this volume, he must give proper credit in his own work.

This Thesis by **Herbert Douglas Barber**
has been used by the following persons, whose signatures attest their acceptance of the above restrictions.

Name and Address

Date

A COMPUTER FOR
DETERMINING HUMAN CARDIAC OUTPUT

A THESIS

Submitted to the Faculty of Graduate Studies
in Partial Fulfilment of the Requirements
for the Degree of
Master of Science
in Electrical Engineering
in the Department of Electrical Engineering
University of Saskatchewan

by

Herbert Douglas Barber

Saskatoon, Saskatchewan
September, 1960



The University of Saskatchewan claims copyright in conjunction with the author. Use shall not be made of the material contained herein without proper acknowledgment.

ACKNOWLEDGMENT

The author hereby wishes to express his thanks to Professor N. F. Moody for his kind assistance and supervision in the preparation of this thesis and to the members of the Department of Electrical Engineering and Cardio Pulmonary Laboratory, University Hospital for their help and co-operation.

CONTENTS

	Page
I Introduction	1
II Indicator dilution method of determining cardiac output	5
III Simulation and extrapolation of indicator dilution curves	10
1. Previous work	10
2. Difference of two exponentials	10
3. Sum of three exponentials	13
4. Elevated cosine and exponential tail	15
5. Area determinations	21
6. Transit time determinations	23
IV Cardiac output computer	30
1. Approach	30
2. Pulse generator	33
3. Oscillator	37
4. Integrator	40
5. Exponential control	44
6. Sweep generator	46
7. Optical system	51
8. Calculator	54
9. Calibration	60
V Conclusion	68
References	70

FIGURES

		Page
1	Cardio-pulmonary system	7
2	(a) Concentration as a function of time (b) Concentration curve showing effects of recirculation	8
3	(a) Difference of two exponentials (b) Typical concentration curve showing inverse curvature (c) Solutions of $\ln x = 2.61 - 5/x$ (d) Curve of $e^{-t/5} - e^{-t/4.6}$ compared to desired curve	12
4	(a) Analogue circuit for three exponentials (b) Waveforms of analogue (c) Comparison of curves	14
5	(a) Elevated cosine with exponential tail (b) Indicator curve to be fitted	17
6	Plot for solution of t_e	19
7	Plot of t_e versus C	20
8	(a) Visual comparison of curves (b) Plot of area versus C	22
9	(a) Definition of mean transit time (b) Volume determined by T_m	25
10	Plot of mean transit time versus C	28
11	Block diagram and waveforms of cardiac output computer	31
12	Pulse generator circuit	35
13	Oscillator circuit	38
14	Integrator circuit	42
15	Exponential control circuit	45

FIGURES (continued)

	Page
16 Sweep generator circuit	48
17 Complete curve generator circuit	50
18 Optical system	52
19	55
(a) Simple calculator circuit	
(b) Error curve of "a" for $R_2:R_1 = 100:1$	
20 Cardiac output calculator	58
21	59
(a) Transit time calculator	
(b) Null meter	
22 Resistance versus $\frac{1}{A}$	62

TABLES

		Page
I	Tabulation of derivatives for values of t_e when $C = 1$	19
II	Values of t_e , $\sin \frac{\pi}{T} t_e$ and $1 - \cos \frac{\pi}{T} t_e$ for various values of C	20
III	Area and area constant, K_A , as a function of C	22
IV	First moment and mean transit time for values of C .	28
V	Impedance Z as a function of C	45
VI	Linear values of K_A and K_T and associated errors ..	62

I INTRODUCTION

Ever since Harvey in 1628 (28) discovered that the blood moved in a circuit within the body, the rate of flow of blood and the output of the heart itself has been of increasing interest and importance. Stephen Hales (28) was probably the first man to do any quantitative work on the problem; an account of this work was published in 1733. He had estimated the rate of blood flow in the aorta (see Fig. 1) of a horse from the capacity of the left ventricle, the diameter of the base of the aorta and the pulse rate. He also did estimates on several other animals including man.

Very little work was done on the problem then until interest was renewed in 1827 by Eduard Hering who made velocity of flow measurements by injecting potassium ferrocyanide at one point and determining its time of arrival by sampling at another point in the vascular circuit and testing the samples withdrawn for prussian blue.

Velocity measurements were attempted later by Volkman in 1850 using a pendulum device which he placed in the blood vessel and by O. Frank using a differential manometer, but no further work was done on the actual output of the heart until G. N. Stewart (25)(26) in 1897 began his work on measuring blood flow through the heart and lungs. Stewart was probably the father of the indicator dilution method of determining cardiac output. Stewart's work was taken up in the 1920's by Hamilton and his colleagues (7)-(11) who did considerable work in justifying and improving Stewart's methods of determining cardiac output and volume of the cardio-vascular bed.

As already mentioned, until Stewart began his work on the output of the heart, there had been little interest in it but by 1929 enough interest had been aroused so that other methods began developing. The Fick principle had been known for many years but the difficulty had been to obtain a sample of mixed venous blood. In 1929, Forssman in Germany introduced a cardiac catheter into his own heart. This technique was subsequently studied in America by Cournand et al in 1941. The Fick (1) principle of flow determination is generally accepted now as the standard method of determining cardiac output. As the blood flows from the pulmonary artery through the pulmonary circulation, the blood picks up oxygen so that the arterial blood has a greater oxygen content than the pulmonary artery or mixed venous blood. The oxygen consumption per minute can be easily determined. As well, samples of arterial, and mixed venous blood can be analysed for their oxygen contents. The formula is as follows:

$$\text{Cardiac Output (L/min)} = \frac{\text{O}_2 \text{ consumption (ml/min)}}{\text{Arterio-venous O}_2 \text{ difference (ml/L)}}$$

Modifications of the Fick principle have been used. Carbon dioxide can be used as the test gas instead of oxygen. Douglas and Haldane eliminated the difficulty of sampling venous blood by using the lung as a tonometer. Grollman in 1929 (6) used acetylene as the test gas to determine cardiac output, again using the Fick principle.

In the last twenty years many methods of cardiac output determination have been developed such as the Ballistocardiograph by Henderson and later by Cournand, pulse and blood pressure techniques employed by Bazett and associates, magnetic procedures and lately ferro-

magnetic resonance techniques have been tried. Most of these methods, however, either have severe operational disadvantages or are still in experimental states.

Of course, efforts to determine cardiac output would be fruitless if its determinations were of no practical importance. However, much valuable information is given by a knowledge of cardiac output and blood transit time through the heart and lungs. At present a surgeon or physician can have the blood pressure, pulse and electrocardiogram continuously available to him during surgery or diagnostic work. If at the same time the cardiac output were available, its correlation with the above information would give a much clearer picture of the condition and reactions of the cardio-vascular system. It is therefore obvious that the determination of cardiac output is not only of general interest but is of considerable importance in medical practice.

To date, the most clinically adaptable method appears to be that using the indicator dilution technique. This method depends upon two important considerations. The indicator that is used must be non-toxic, even in large doses. The unit used for the detection of the dilution must be sensitive only to that indicator.

The indicator may be either a chemical dye and the recording apparatus a densitometer, or an isotope with the detecting unit being a radiation monitor.

Indicator dilution curves depend for their validity upon satisfactory and complete mixing of the dye with the blood. In addition, it is assumed that the densitometer samples a representative portion of that blood.

Recent work (17) has shown that the indicator dilution technique for cardiac output determination has many advantages over the other methods mentioned above. This method allows the determination of cardiac output on severely ill patients. It is also possible to make repeated measurements, and in addition this method allows the determination of other important cardiovascular indices.

However, a technician must spend between 30 and 60 minutes analysing each curve before all the answers are available. Thus, while this technique has many advantages, this time factor is one criticism.

It was therefore thought desirable to design a computer which would allow the rapid determination of these important cardio-pulmonary variables. Such a computer should be technically and operationally as simple as possible and should have an accuracy consistent with the accuracy of the method of determination.

II INDICATOR DILUTION METHOD OF DETERMINING CARDIAC OUTPUT

The determination of cardiac output by the indicator dilution method is based on the measurement of the varying concentration of an injected substance as it passes through the heart. If a small amount of highly concentrated material is injected into the inflow tract the average dilution of the material coming out will be a direct indication of the volume passing through the heart and causing the observed dilution. The measurement of the change of concentration during an interval of time thus permits the output to be expressed as a volume of flow per unit time.

If a certain quantity, I , of indicator is injected into a flow system the same quantity must flow out of the system. Because of mixing, diffusion, different lengths of path in the system and velocity distributions due to laminar flow areas and different frictional coefficients of the conduits; the concentration of the substance as it flows out will in general be some function of time, $c(t)$. It can be stated however that at any time, t_0 , the rate at which the injected material is flowing out will be the product of the rate of flow, F , and the concentration $c(t_0)$. Thus for a period from t_0 to $t_0 + \Delta t$ (see Fig. 2 (a)) the amount of the material which flows out will be $Fc(t_0)\Delta t$. Now it can easily be seen that if all of these amounts are summed over the whole range of time the sum must equal the amount of material injected. Thus in equation form:

$$I = \int_t F c(t) dt .$$

If the rate of flow, F , is assumed constant over the interval of time involved the equation can be arranged thus:

$$F = \frac{I}{\int_t c(t) dt} .$$

The rate of flow then is a quotient of the amount of indicator injected and the area of the time-concentration curve. This formula is in fact the Stewart-Hamilton equation.

The method of determining the output of the heart by indicator dilution is as follows: An indicating substance is injected into a vein carrying blood from the body to the heart (see Fig. 1). It travels up the vein and into the right auricle then to the right ventricle from which it is forced, completely mixed with all blood entering the heart, into the lung bed via the pulmonary artery. After passing through the lung bed it enters the left auricle of the heart, is forced into the left ventricle and from there into the aorta and on to the body again. At some point not too distant from the heart the blood is sampled and the indicator concentration with time recorded. One method of recording this concentration is to use a dye indicator and then record the light absorption of the blood by means of a photo cell and light deflecting galvanometer which records continuously on instantly developing photographic paper. This should give sufficient information to determine by the Stewart-Hamilton method the heart output, however, before all the indicator has been pumped from the heart the first particles of indicator to leave the heart have already begun to enter again. Some of the circulation paths in the body are quite short and thus before primary circulation is complete secondary circulation begins as shown in

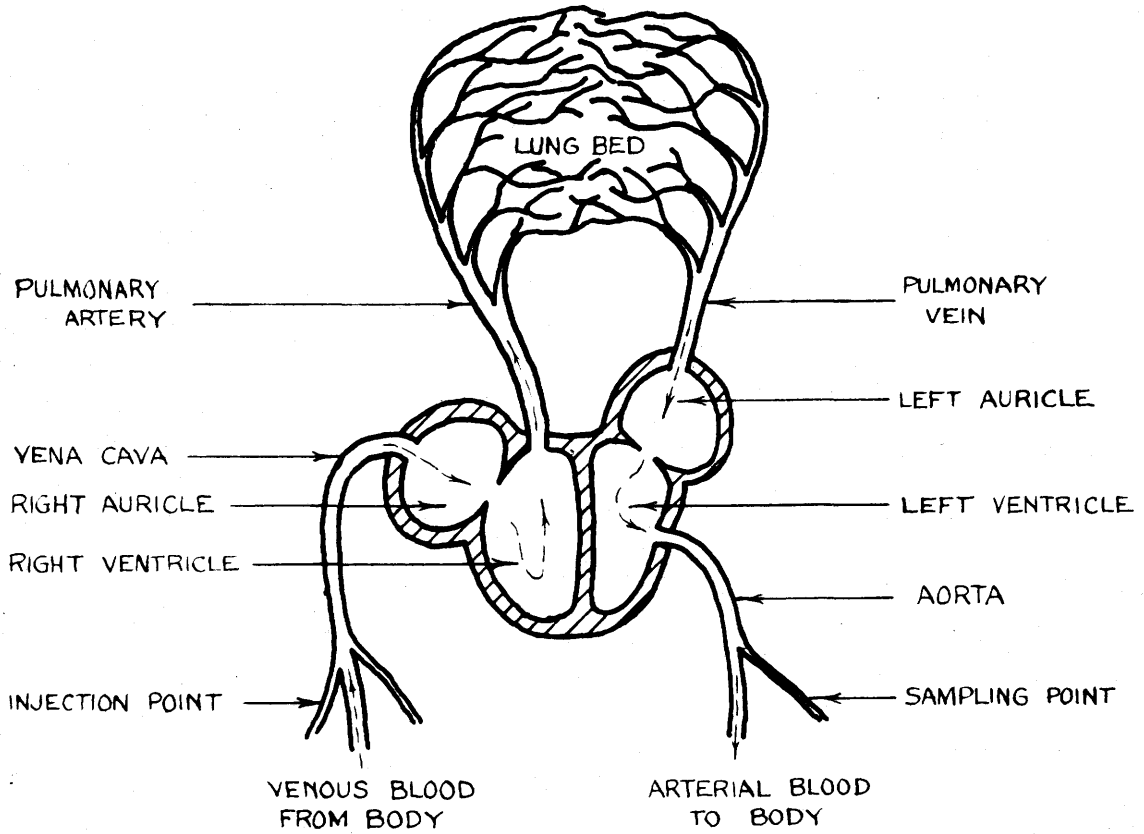
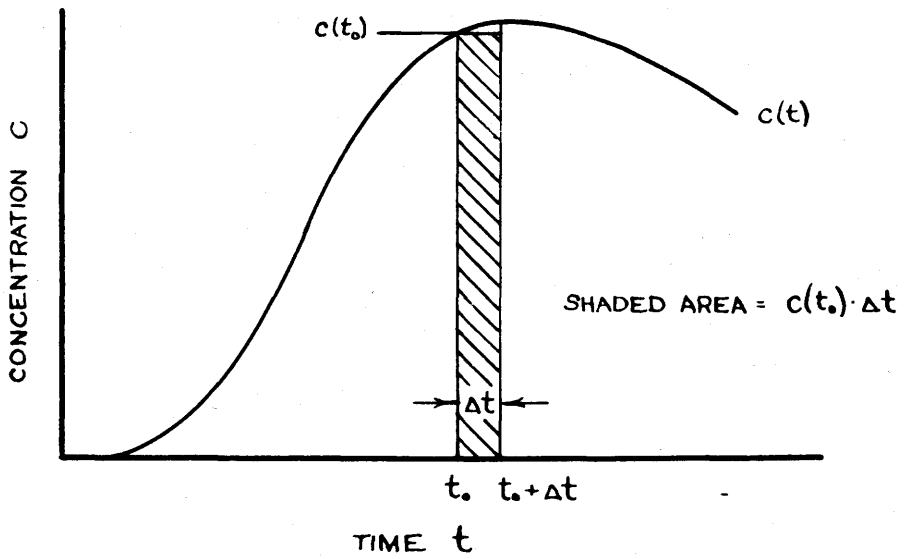
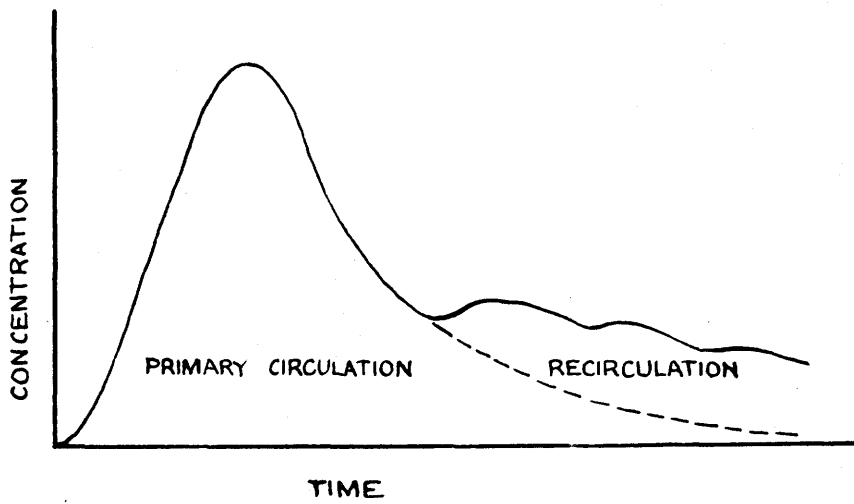

FIGURE 1
Cardio-pulmonary system



(a) Concentration as a function of time



(b) Concentration curve showing affects of recirculation.

Figure 2

Fig. 2(b). Since the primary circulation only is required for cardiac output determinations there must be some way of determining the remaining part of the primary circulation curve before the required integration can be performed.

There has been some argument about how the concentration curves should be terminated. Considerable work has been done by Hamilton (8)(9) and others who feel that, both from theoretical and experimental considerations the curves probably end in an exponential. Parrish (19) set up an analogue system to determine the transfer function of the lungs and he felt that from his observations an exponential decay was in error especially for the determination of transit times. In spite of these conflicting opinions experimental work with non-recirculating systems seems to point to an exponential decay and the fact that exponential extrapolation of indicator dilution curves give satisfactory accuracy in the determination of cardiac output indicates that its use is justifiable.

In the presence of valvular insufficiency, the time required for the heart to completely expel the "dyed blood" is prolonged and this is reflected in the indicator dilution curve by a prolongation of the descending limb. However, the determination of cardiac output from such a curve is valid. Thus, a computer for determining cardiac output should be capable of coping with normal and "regurgitation" curves.

At present the indicator dilution curves are analysed by plotting the descending limb of the curve on semi-log paper to determine the exponential. The area under the primary circulation curve thus plotted is determined by a planimeter. Therefore, there is a real need for a computer to determine human cardiac output.

III SIMULATION AND EXTRAPOLATION OF INDICATOR DILUTION CURVES

1. Previous work

Some work has been done on attempting to simulate and extrapolate indicator concentration curves by analogue computers. Parrish (19) and his colleagues have done considerable work on simulating the cardio-pulmonary system by means of delay line, but such a system is very complex and requires the adjustment of many variables to obtain the desired output.

Recently Skinner and Gehmlich produced an analogue computer (22) which uses the initial part of the indicator dilution curve and by a sensing circuit affixes the most probable exponential at a time determined by the sensing circuit. This appears to be a very good machine and will in fact cope with some abnormalities in the curves. This machine is however quite complex, involving ten operational amplifiers, a function generator, a multiplier and a tape recorder. Apparently only the curve area is produced by this method and hence the cardiac output and mean transit time must still be calculated.

It should be possible to simulate normal dilution curves with acceptable accuracy by some simple function. The following parts are a discussion of the methods used in attempting to simulate and extrapolate the curve.

2. Difference of Two Exponentials

Except for the small shaded tail of Fig. 3(b) it should be possible to fit the indicator dilution curve with the difference of

two exponentials if the following conditions are met:

(a) The overriding exponential with time constant of z of Fig. 3(a) must be much greater than the exponential with time constant x if a significant amplitude is to be obtained and if the time constant of the decay exponential is not to be appreciably affected by x when t is large. This is equivalent to saying that the decay time constant of the curve must be approximately equal to z .

(b) The amplitude of the two exponentials must be equal since the difference curve must start at zero.

(c) When the above conditions are fulfilled it must be possible to obtain a maximum at $t = T$ (see Fig. 3(b)) if the curve peaks are to match with respect to time. Then it must be possible for $\frac{dy}{dt} = 0$ when $t = T$, where:

$$y = A (e^{-t/z} - e^{-t/x})$$

Hence

$$\frac{dy}{dt} = -A (\frac{1}{z} e^{-t/z} - \frac{1}{x} e^{-t/x}) .$$

When $t = T$, and $\frac{dy}{dt} = 0$

$$\text{then } \frac{1}{z} e^{-T/z} = \frac{1}{x} e^{-T/x}$$

By taking logarithms

$$\ln x = \ln z + \frac{T}{z} - \frac{T}{x} \quad \text{--- (1) .}$$

For any actual curve T is already determined and z is very closely determined since it is approximately equal to the decay time constant which in turn is generally very nearly equal to T . Since this is a common case it may be used to test the feasibility of using two exponentials.

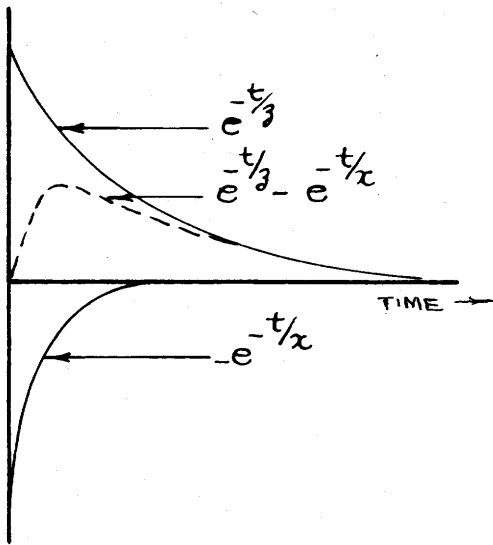

(a) Difference of two exponentials

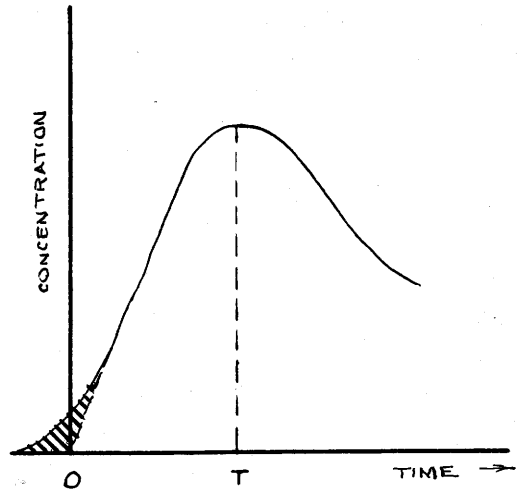

(b) Typical concentration curve showing inverse curvature

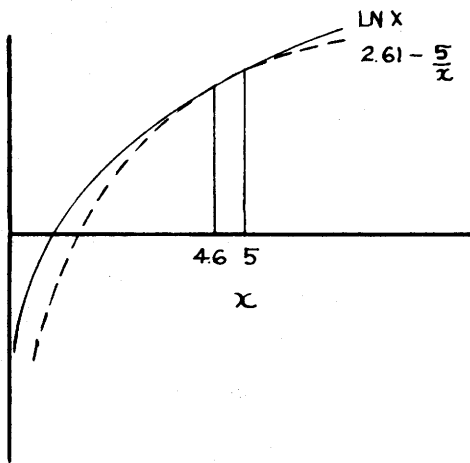

(c) Solutions of $\ln x = 2.61 - 5/x$

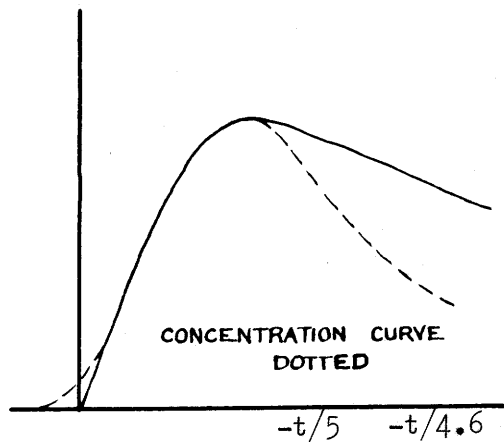

(d) Curve of $e^{-t/5} - e^{-t/4.6}$ compared to desired curve

Figure 3

Then for $z = T$ substituting into the equation (1) of condition (c)

$$\ln x = \ln T + 1 - \frac{T}{x}$$

This equation is solved graphically in Fig. 3(c) for $T = 5$, a common value. Two curves $y = \ln x$ and $y = \ln 5 + 1 - \frac{5}{x}$ are plotted and the points of intersection indicate the solutions of the above equation.

One solution always exists when $x = z$ but this is a zero amplitude curve and hence is of no interest.

The other solution is at $x = 4.6$. A plot of this curve in Fig. 3(d) shows that condition (a) has not been satisfied and since x is almost equal to z the curve is quite flat.

This curve cannot then be used to match the dilution curves since it may be possible to fit only a very limited number.

3. Sum of Three Exponentials

A function with three exponentials rather than two will give some inverse curvature at the beginning of the curve not possible with two exponentials and may possibly be made to fit. However, since three exponentials become quite difficult to plot an analogue was set up which would generate the sum of three exponentials and at the same time plot the resulting curve on an X - Y recorder. The circuit and waveforms are shown in Fig. 4(a) and (b).

In the analogue two integrating type of circuits with time constants τ_1 and τ_2 were used followed by a differentiating type of circuit with a time constant of τ_3 .

The transfer function of this circuit is

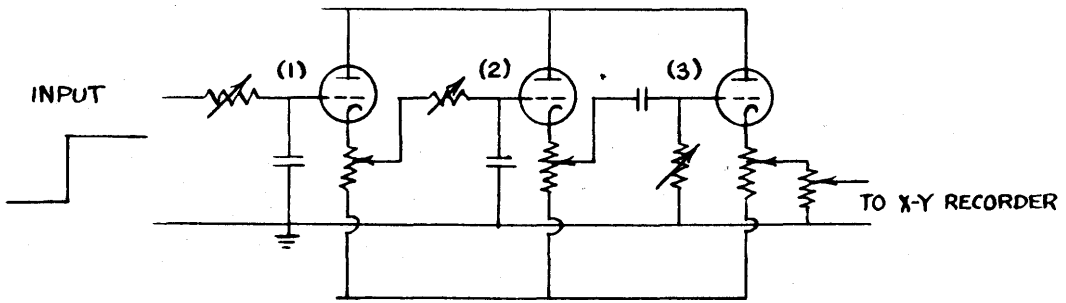

(a) Analogue circuit for three exponentials

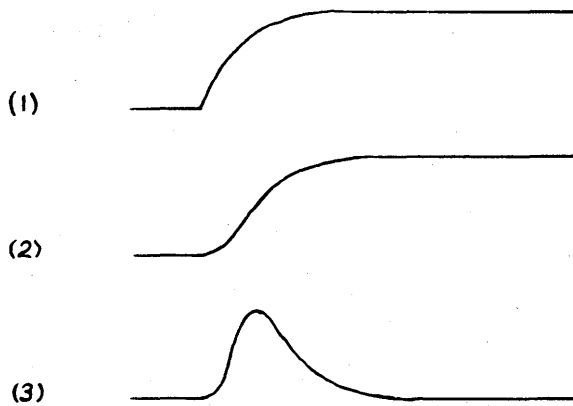

(b) Waveforms of analogue

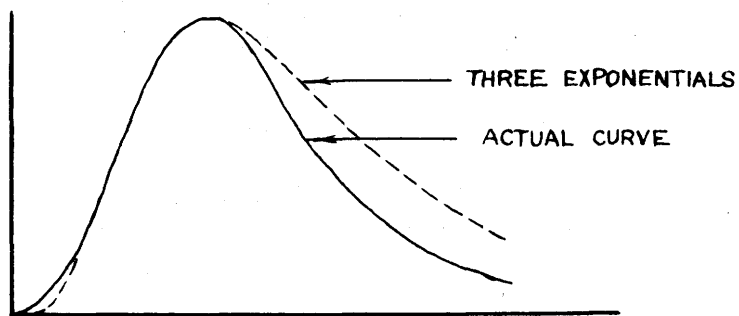

(c) Comparison of curves

Figure 4

$$\frac{\tau_3 s}{(1 + \tau_1 s)(1 + \tau_2 s)(1 + \tau_3 s)}$$

The output of this circuit when the input is a delta function

$$\frac{\tau_3}{\tau_1(\tau_3^2 - \tau_1^2) + \tau_2(\tau_1^2 - \tau_3^2) + \tau_3(\tau_2^2 - \tau_1^2)} \left[(\tau_3 - \tau_2)e^{-t/\tau_1} + (\tau_1 - \tau_3)e^{-t/\tau_2} + (\tau_2 - \tau_1)e^{-t/\tau_3} \right]$$

This serves to show that the output of the circuit is a very complicated function of the time constants and that all three parameters affect all parts of the curve.

When the parameters of a function generator have no independent effects upon the function being generated it becomes quite difficult to match a curve with any speed and the method of adjusting the parameters becomes quite random. This was born out by attempts to fit actual curves.

In the attempts made to fit indicator curves it became apparent that this curve would not fit enough of the indicator curves with sufficient accuracy to warrant its use. The fit was much better than that obtained with two exponentials but was still much too flat on top when the proper time and amplitude dimensions were obtained. (See Fig. 4(c). In fact it appeared that it would be impossible to obtain enough symmetry about the peak concentration point without using additional time constants in the analogue. This would greatly increase the complexity so it was not attempted.

4. Elevated Cosine and Exponential Tail

In attempting to fit the indicator curves with the above function the following assumptions are made. The initial part of each indicator concentration curve is an elevated cosine wave of variable

frequency and amplitude which is terminated by an exponential appearing at some time t_e after peak concentration has been reached (see Fig. 5(a)). The time, t_e , at which the exponential begins is determined by the point at which the rate of change of the elevated cosine of half period T is equal to the rate of change of an exponential with time constant CT and amplitude equal to the value of the elevated cosine at time t_e . The reason for making this last assumption will be obvious when the curve generating circuitry is discussed.

The curve obtained in this manner is quite simple to compute and plot mathematically since it has only three parameters, namely, the half period, T , of the cosine wave (related to the frequency), the amplitude of the cosine wave, A , and the time constant of the exponential CT . It has been mentioned before that the time constant of the exponential is generally very nearly equal to T and thus can be related to it by a factor, C , which has a relatively small range of variability.

To fit an indicator dilution curve as shown in Fig. 5(b) the time to the peak T and the peak concentration c_p must be measured. It should be noted that the peak concentration is equal to the peak to peak amplitude of the cosine wave or twice the normal amplitude A . Thus A can be determined from c_p and the equation of the required cosine wave becomes.

$$\frac{c_p}{2} (1 - \cos \frac{\pi}{T} t) \text{ or } A (1 - \cos \frac{\pi}{T} t)$$

By measuring the time required for the exponential to decay by $(1 - \frac{1}{e})$ or 0.632 of its value at any point it is possible to determine approximately the value of CT as shown in Fig. 5(b). This determines the equation of the exponential as:

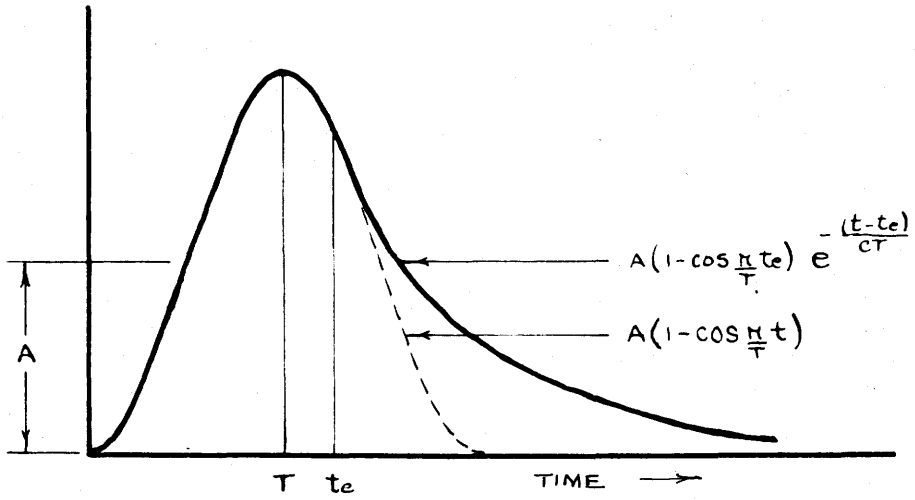

(a) Elevated cosine with exponential tail

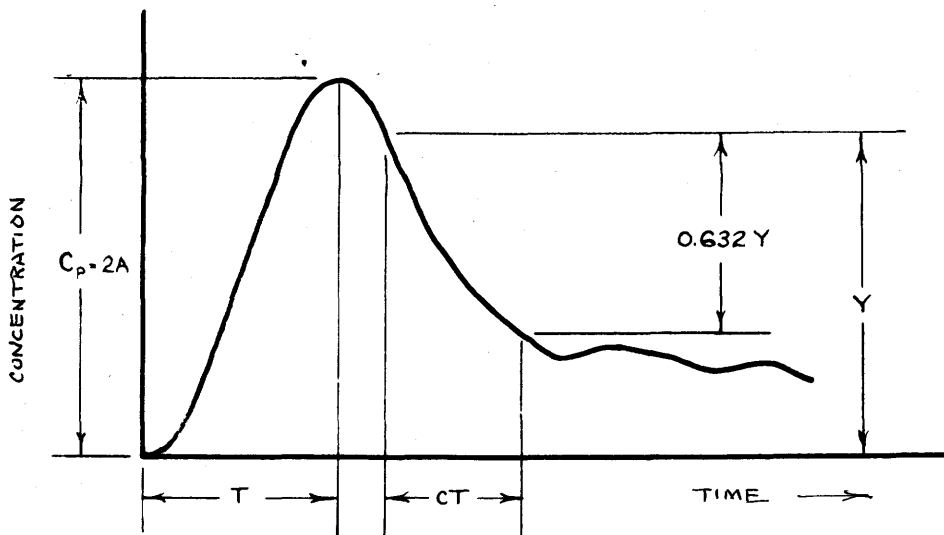

(b) Indicator curve to be fitted

Figure 5

$$\frac{c_p}{2} \left(1 - \cos \frac{\pi}{T} t_e\right) e^{-\frac{(t-t_e)}{CT}} \text{ or } A \left(1 - \cos \frac{\pi}{T} t_e\right) e^{-\frac{(t-t_e)}{CT}} .$$

Then to make an approximate plot of this curve the only remaining unknown is t_e , the time at which the exponential begins. This can be calculated by use of the assumption of equal derivatives at $t = t_e$ as follows:

$$\frac{d}{dt} \left[A \left(1 - \cos \frac{\pi}{T} t\right) \right] = \frac{A\pi}{T} \sin \frac{\pi}{T} t$$

$$\frac{d}{dt} \left[A \left(1 - \cos \frac{\pi}{T} t_e\right) e^{-\frac{(t-t_e)}{CT}} \right] = -\frac{A}{CT} \left(1 - \cos \frac{\pi}{T} t_e\right) e^{-\frac{(t-t_e)}{CT}}$$

$$\sin \frac{\pi}{T} t_e = \frac{\cos \frac{\pi}{T} t_e - 1}{\pi C} .$$

To solve this equation for t_e given a value of C , both sides must be plotted with respect to t_e as a variable and the intersection of the two curves will give the solution. This is illustrated in table I which gives several values of each function as t_e varies when $C = 1$ and in Fig. 6 which shows the plots of these values and the point of intersection of the two curves which is the required value of t_e .

It is of considerable interest to note that for a given value of C , t_e is a function of T only. This relationship has been calculated in the manner explained above for several values of C . The results are tabulated in table II and graphed in Fig. 7.

With this information available it was possible to plot curves in an attempt to simulate actual concentration curves by using values of T , A and CT scaled from the actual concentration curves as illus-

t_e	$-\text{SIN } \frac{\pi}{T} t_e$	$-(\cos \frac{\pi}{T} t_e - 1) / \pi$
T	0	0.636
1.1T	0.309	0.621
1.2T	0.587	0.575
1.3T	0.808	0.505
1.4T	0.950	0.416
1.5T	1.000	0.318

Table I - Tabulation of derivatives for values of t_e when $C = 1$

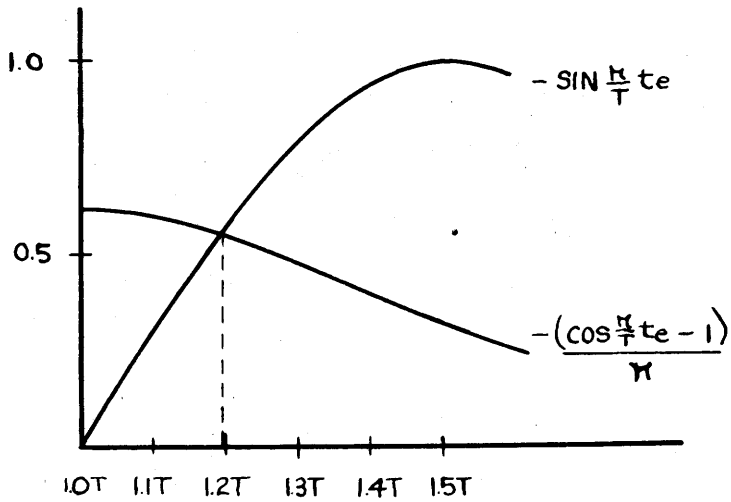

Figure 6 - Plot for solution of t_e

c	t_e	$-\sin \frac{\pi}{T} t_e$	$1 - \cos \frac{\pi}{T} t_e$
0.6	1.310T	0.8274	1.562
0.7	1.273T	0.7547	1.656
0.8	1.241T	0.6863	1.727
0.9	1.216T	0.6290	1.777
1.0	1.197T	0.5780	1.816
1.2	1.163T	0.4899	1.872
1.4	1.140T	0.4279	1.904
1.8	1.112T	0.3425	1.940

Table II - Values of t_e , $\sin \frac{\pi}{T} t_e$ and $1 - \cos \frac{\pi}{T} t_e$ for various values of C.

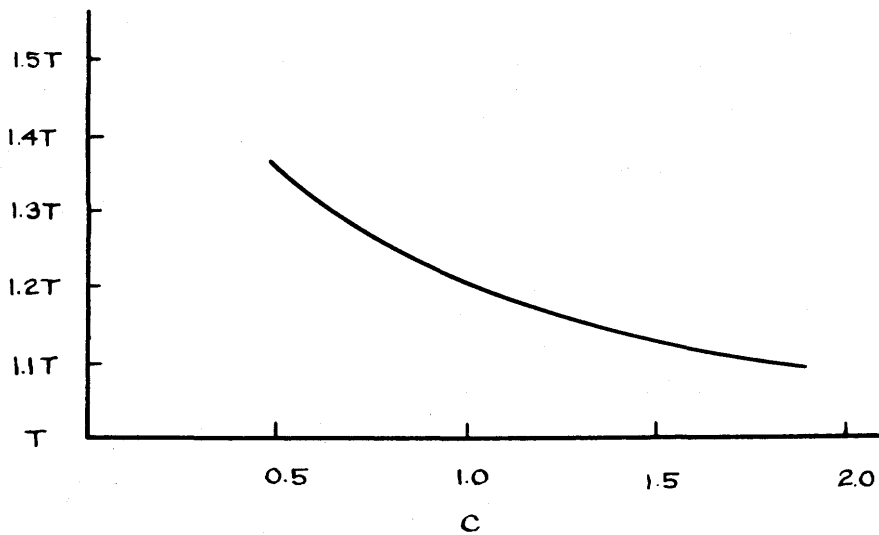

Figure 7 - Plot of t_e versus C

trated in Fig. 5(b). Several plots were made in this manner and all appeared to fit very closely except the plotted curves were in every case somewhat more peaked than the actual concentration curve as illustrated in Fig. 8(a). However the fit looked very promising since the error appeared small and could probably be minimized by more accurate fitting.

To check the fit more accurately area determinations and comparisons were carried out as described in the following section.

5. Area Determinations

Determining the area of the elevated cosine curve is simply a matter of integrating the cosine curve to t_e and adding to it the integral of the exponential from t_e to infinity for given values of A, T and C. The following sample calculation is done for C = 1.

$$A_{\cos} = \int_0^{t_e} A(1 - \cos \frac{\pi}{T} t) dt = \int_0^{1.197T} A(1 - \cos \frac{\pi}{T} t) dt$$

$$= A \left[T - \frac{T}{\pi} \sin \frac{\pi}{T} t \right]_0^{1.197T} = 1.381 AT$$

$$A_{\exp} = \int_{t_e}^{\infty} A(1 - \cos \frac{\pi}{T} t_e) e^{-\frac{(t-t_e)}{CT}} dt$$

$$= AT (1 - \cos(1.197\pi)) = 1.815 AT$$

$$\text{Total Area } A_T = 3.197 AT .$$

It should be noted that for any value of C area becomes a function of the amplitude A, and the half period T. Since this is the case area as a function of A and T was calculated for several values of

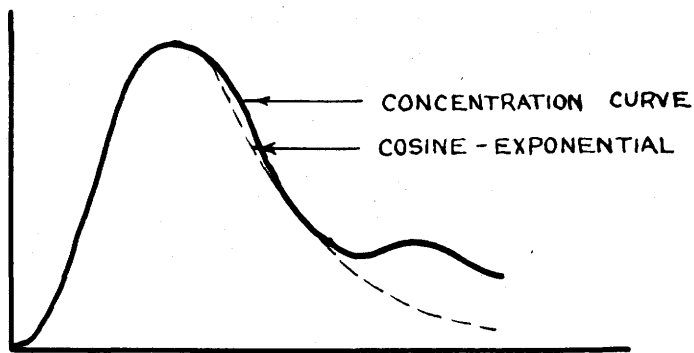

(a) Visual comparison of curves

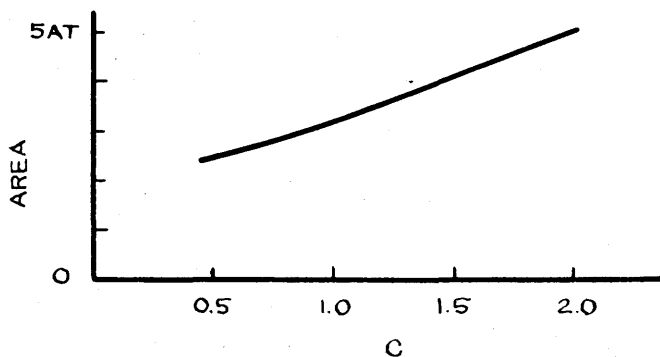

(b) Plot of area versus C

Figure 8

C	AREA	K_A
0.6	2.510 AT	2.510
0.7	2.672 AT	2.672
0.8	2.841 AT	2.841
0.9	3.016 AT	3.016
1.0	3.197 AT	3.197
1.2	3.567 AT	3.567
1.4	3.943 AT	3.943
1.8	4.711 AT	4.711

Table III - Area and area constant, K_A , as a function of C

C, tabulated in table III and plotted in Fig. 8(b). It is important to note that the area and C are almost linearly related by a factor K_A .

The areas of curves drawn to match actual indicator dilution curves were calculated in this manner and the largest discrepancy obtained from actual curve values was less than six per cent. Most of the areas were somewhat larger than the concentration curve areas which indicates that the presence of a full exponential compensates for the greater pointedness of the constructed curves.

These calculations seem to indicate that this method of area determination is feasible and they also illustrate the simplicity of the curve. The area is almost a linear function of C, T and A, parameters which are completely independent of each other.

The actual heart output is then a simple function of; the amount of indicator injected I, a calibration factor M, and the area of the curve $K_A AT$.

In equation form:

$$\text{Cardiac Output} = \frac{IM}{K_A AT}$$

6. Transit Time Determinations

A knowledge of blood transit time through the heart and lungs makes it possible to calculate the volume of the cardio-pulmonary system at the time of measurement. At present calculation of the mean transit time is a very laborious procedure since it requires the determination of the first moment of the corrected indicator concentration curve.

The mean transit time, T_m , is the time from the centre of moments of the injected pulse to that of the concentration curve (see Fig. 9(a)) or the average interval of time for particles to travel from the injection site to the sampling site. The cardio-pulmonary volume ^{*} is calculated by determining the amount of blood which must flow out of the system at a rate F in the time between injection and appearance at the sampling point. This volume is:

$$V = F T_m .$$

It represents not only the cardio-pulmonary volume but also the volume of all blood flowing to the heart in the time from injection until the indicator reaches the heart and the volume of all blood flowing out of the heart from the time of ejection from the heart until the indicator reaches the sampling point. This is illustrated by the shaded area in Fig. 9(b).

If the injection and sampling sites are chosen close to the heart on a main vein and artery respectively, the time of arrival at the heart and time from ejection to sampling can be minimized and, in fact, quite accurately determined. This means that if the mean transit time is known the cardio-pulmonary volume can be calculated with a reasonable degree of accuracy.

The calculation of, t_m , the centre of moments of the indicator distribution about its own origin is the difficult part of determining T_m . It requires the determination of the moment of the area of the concentration curve about its point of appearance t_a (see Fig. 9 (a)) and division by the area of the concentration curve. In mathematical form this is expressed as follows:

* Central blood volume.

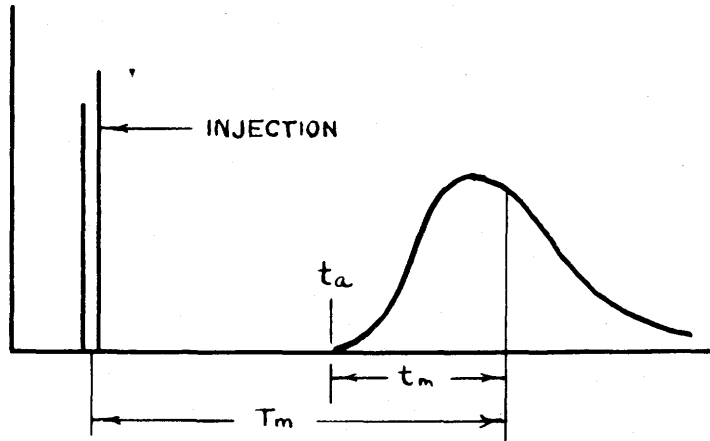

t_a - appearance time
 t_m - mean transit time from t_a
 T_m - mean transit time from injection

(a) Definition of mean transit time

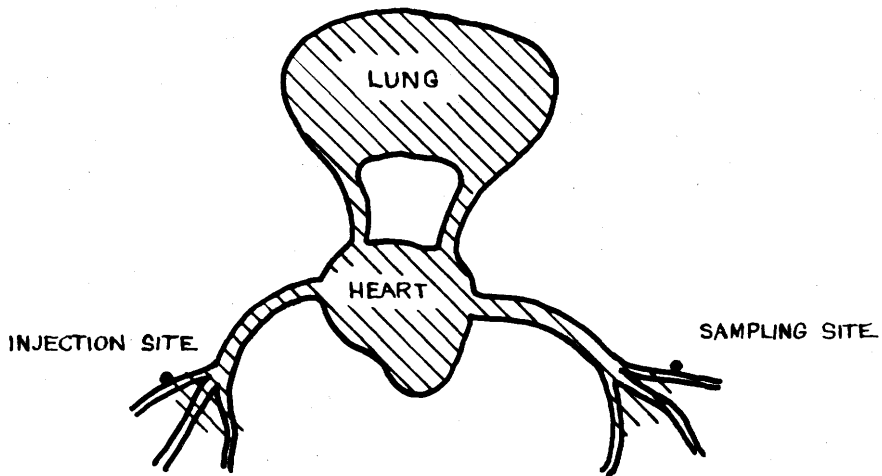

(b) Volume determined by T_m

Figure 9

$$t_m = \frac{\sum_{t_a}^t ct}{\sum_{t_a} c}$$

or

$$t_m = \frac{\int_{t_a}^{\infty} ct dt}{\int_{t_a}^{\infty} c dt}$$

For the elevated cosine - exponential curve the area term has been calculated and the determination of the first moment M_1 , is simply a matter of performing the integral in the numerator of the above expression. This will be done generally and then, by way of illustration, for a value of $C = 1$ in the following treatment.

$$M_1 = \int_{t_a}^{\infty} ct dt = M_1 \cos + M_1 \exp.$$

Now if t_a is used as the origin of the curve

$$M_1 = \int_0^{t_e} At(1 - \cos \frac{\pi}{T} t) dt + \int_{t_e}^{\infty} A(1 - \cos \frac{\pi}{T} t_e) t e^{-\frac{(t-t_e)}{CT}} dt$$

$$\begin{aligned} M_1 \cos &= \int_0^{t_e} At(1 - \cos \frac{\pi}{T} t) dt \\ &= A \left[\frac{t^2}{2} - \frac{T}{\pi} t \sin \frac{\pi}{T} t - \frac{T^2}{\pi^2} \cos \frac{\pi}{T} t \right]_0^{t_e} \\ &= A \left[\frac{t_e^2}{2} - \frac{T}{\pi} (t_e \sin \frac{\pi}{T} t_e) + \frac{T^2}{\pi^2} (1 - \cos \frac{\pi}{T} t_e) \right] \end{aligned}$$

$$M_1 \exp = \int_{t_e}^{\infty} A(1 - \cos \frac{\pi}{T} t_e) t e^{-\frac{(t-t_e)}{CT}} dt$$

$$\begin{aligned}
 &= -ACT (1 - \cos \frac{\pi}{T} t_e) e^{t_e/CT} \left[\frac{-t/CT - t/CT}{t_e + CTe} \right]_{t_e}^{\infty} \\
 &= CTA (1 - \cos \frac{\pi}{T} t_e) [CT + t_e] .
 \end{aligned}$$

The total moment is the sum of these two expressions as shown above.

When C = 1 from table II

$$t_e = 1.197 T$$

$$\sin \frac{\pi}{T} t_e = -0.578$$

$$1 - \cos \frac{\pi}{T} t_e = 1.816 .$$

Then

$$\begin{aligned}
 M_1 \cos &= A \left[\frac{(1.197 T)^2}{2} + \frac{T(1.197 T)(0.578)}{\pi} + \frac{T^2}{\pi^2} (1.816) \right] \\
 &= AT^2 [0.7163 + 0.2205 + 0.1842] \\
 &= 1.121 AT^2
 \end{aligned}$$

$$\begin{aligned}
 M_1 \exp &= AT (1.816) [T + 1.197 T] \\
 &= AT^2 (1.816)(2.197) \\
 &= 3.990 AT^2
 \end{aligned}$$

$$M_1 = M_1 \cos + M_1 \exp = 5.111 AT^2 .$$

From table II when C = 1 the area is 3.197 AT.

Hence

$$t_m = \frac{5.111 AT^2}{3.197 AT} = 1.595 T .$$

In a similar manner the value of M_1 and t_m were determined for several values of C and are tabulated in table IV and graphed in Fig= 10. Again it should be noted that t_m is almost a linear function

C	AREA	M_1	t_m	K_T
0.6	2.510 AT	3.152 AT ²	1.255 T	1.255
0.7	2.672 AT	3.572 AT ²	1.337 T	1.337
0.8	2.841 AT	4.038 AT ²	1.422 T	1.422
0.9	3.016 AT	4.543 AT ²	1.504 T	1.504
1.0	3.197 AT	5.111 AT ²	1.595 T	1.595
1.2	3.567 AT	6.363 AT ²	1.783 T	1.783
1.4	3.943 AT	7.779 AT ²	1.972 T	1.972
1.8	4.711 AT	11.096 AT ²	2.359 T	2.359

Table IV - First moment and mean transit time for values of C

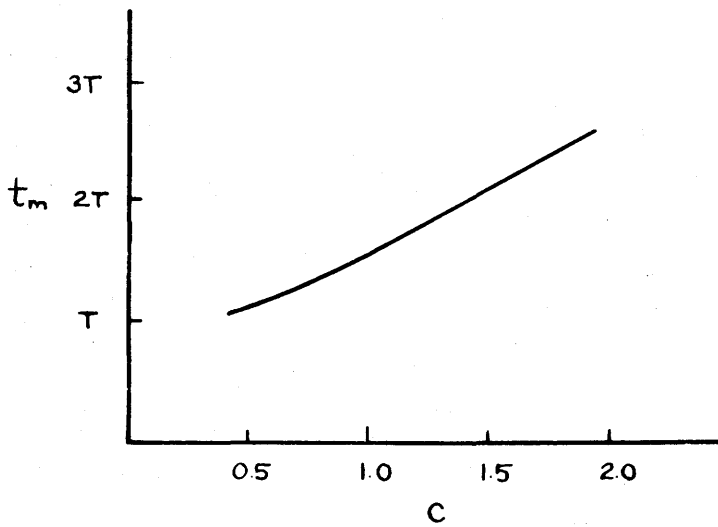

Figure 10 - Plot of mean transit time versus C

of C in the region of interest and is directly related to the half period T of the cosine wave by a factor K_t .

IV CARDIAC OUTPUT COMPUTER

1. Approach

The purpose of the cardiac output computer is to generate a function to simulate the indicator concentration curve and to determine from the curve generated the cardiac output and mean transit time.

The elevated cosine with an exponential tail is a relatively easy curve to generate. It requires an oscillator to supply a sine wave as shown in Fig. 11(2), an integrator to convert this to a cosine wave and elevate it with respect to the zero axis as shown in Fig. 11(3) and an exponential control which will affix an exponential to this elevated cosine at the proper point. Since only one oscillation is desired in one period of time a control circuit or pulse generator is required to gate one oscillation from the oscillator at a time and to control the interval of time between oscillations. This interval of time must be sufficient for the circuit to reach its stable state again after having produced the curve once.

The output of the curve generating circuit is a time varying voltage which may be viewed by means of an oscilloscope. The output of the galvanometer used in tracing the indicator concentration curves is recorded on instantly developing photographic paper and thus may be compared visually to the generated curve by means of an optical system. The optical system superimposes the oscilloscope image and that of the photographic trace, thus enabling the operator to visually fit the generated curve to the concentration curve by varying the parameters of the generated curve.

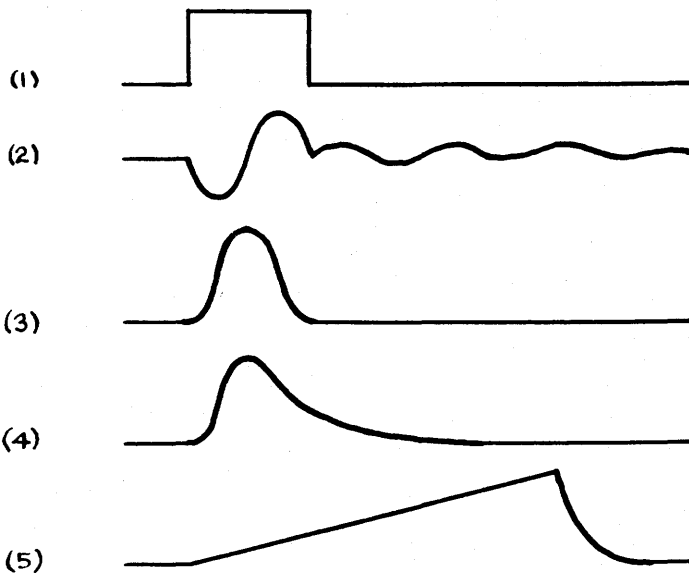
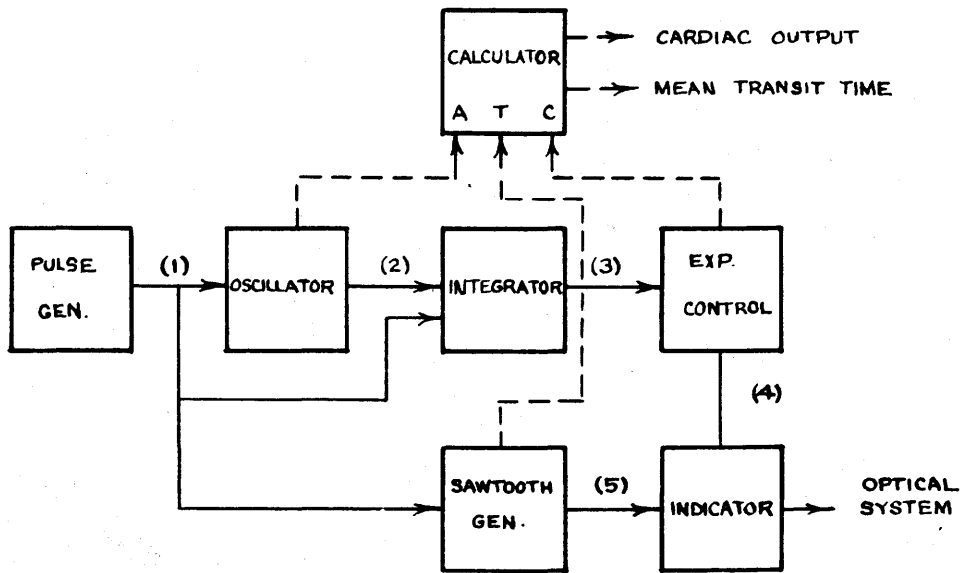

Figure 11 - Block diagram and waveforms of cardiac output computer

As already pointed out the heart output and mean transit time are simple, almost linear functions of the parameters of the generated curve. Thus a calculator could be coupled directly to the parameter controls to give direct readings of cardiac output and mean transit time when a curve is fitted.

Having determined then a general approach to the problem, the methods of parameter control must be considered. The amplitude A may easily be controlled by varying the output amplitude of the oscillator. For the half period T of the cosine wave and the exponential time constant CT , all calculations were made with the exponential time constant directly related to the half period T , by a factor C . This would indicate that the half period control and the exponential control should be directly coupled so that when T varies the exponential time constant varies accordingly. The factor, C , could then be included as a differential control of exponential time constant for cases where the exponential time constant and half period of the cosine wave are not equal.

Since the generated curve of interest is a visual display on an oscilloscope there are two possible ways of varying T for both the cosine wave and the exponential. One is to hold the sweep rate of the oscilloscope constant and vary the frequency of the cosine wave and the exponential simultaneously. The other is to fix the frequency of the cosine wave and the time constant of the exponential except, of course, for the differential C , and control the sweep rate of the oscilloscope.

The second method was chosen since the first required a variable frequency oscillator, a variable pulse width, pulse generator to allow for gating of a full cycle over the range of frequencies used, and an

exponential control variable not only over the range of T but also over the additional range of the differential control C . The second method is obviously the simplest since it requires a fixed pulse width; fixed frequency and only variation of the exponential sufficient for the differential control. It does however require a calibrated sweep generator for the oscilloscope as included in the block diagram of Fig. 11.

Since the sweep must be provided and only vertical and horizontal position controls are required it was decided to use a type 360 Tektronix indicator rather than a full oscilloscope and to power it and the rest of the computer with a Tektronix 160A power supply.

2. Pulse Generator

The purpose of the pulse generator as already mentioned is twofold. It must supply a gating pulse to the circuit, which initiates operation and gates one full oscillation from the oscillator. It must also determine the rate at which generation of the curve is repeated.

The rate at which the curve is repeated is determined by two factors. It must be slow enough to ensure that both the oscillator and the sweep generator have recovered to their stable states before the next gating pulse occurs and it must be fast enough so that the oscilloscope trace maintains a satisfactory intensity.

The time required for the oscillator to recover to its stable state is determined by the damping of the oscillator circuit. The damping of the oscillator circuit must, however, be kept to a minimum if a stable amplitude sine wave is to be produced. Experimental work has shown that the length of time between pulses should be at least twenty times the period of the sine wave being gated.

The time required for the sweep generator to recover is determined largely by the maximum length of sweep required. When the sweep is longest the period of the wave on the oscilloscope appears shortest and when the sweep is shortest the period of the wave appears longest. In all the curves checked the longest period for the cosine wave was never greater than four times the shortest period. Thus the longest sweep period should be four times the shortest required sweep period. Now any curve can be fitted within one and one half periods of the cosine wave, since recirculation generally occurs at about that time. Hence, if the shortest sweep is one and one half periods long, the longest sweep will be six periods. It is obvious then that the damping of the oscillator circuit determines the repetition rate since twenty periods would be more than ample for the sweep generator to recover to its stable state.

The pulse width was chosen at forty microseconds thus automatically setting the oscillator frequency at approximately twenty-five kilocycles. This width and frequency was chosen since it gives a good repetition rate under the above conditions, it keeps A-C coupling time constants within reasonable limits and makes the period of the cosine wave long enough so that any nonlinearity in the sweep in the first few microseconds would not appreciably affect the oscilloscope trace.

The circuit designed to meet these requirements is shown together with waveforms in Fig. 12. It is a free running multivibrator which operates as follows. The tube T_1 is normally bottomed^{*} with the grid drawing grid current at approximately cathode potential. Suppose the grid of T_2 to be at some negative potential with C_1 charging towards

* Saturated.

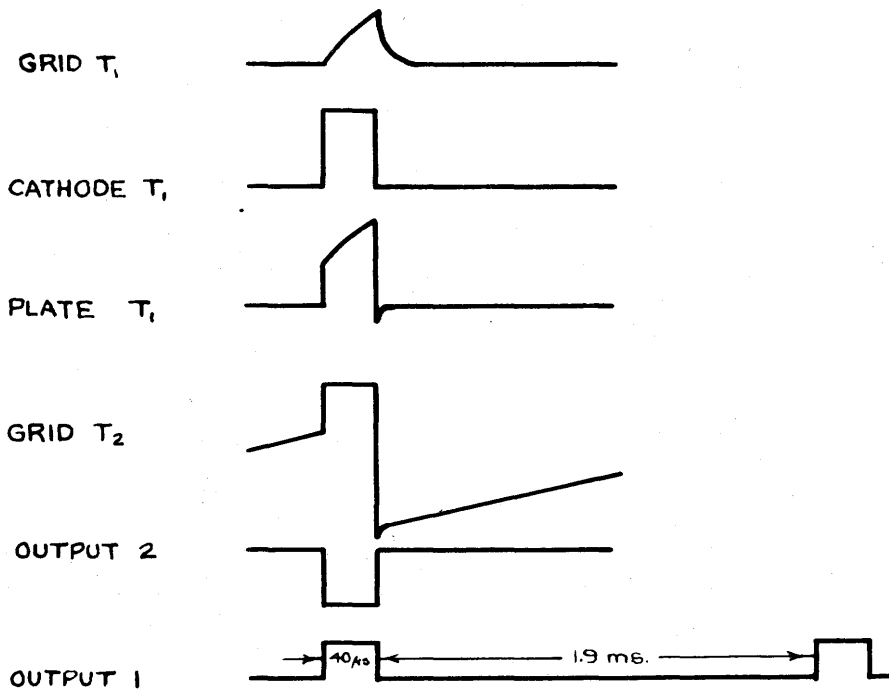
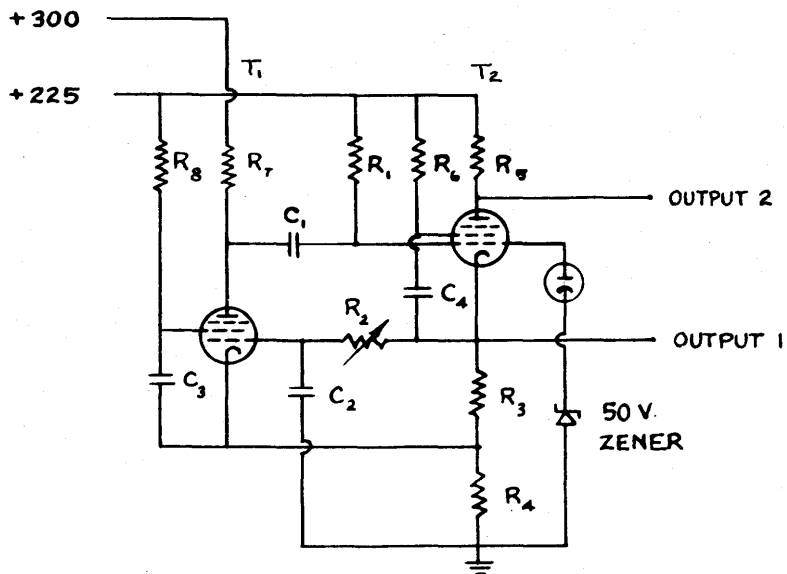

Figure 12 - Pulse generator circuit

225 volts through R_1 . As C_1 charges the grid of T_2 rises until T_2 starts to turn on. The circuit is designed so that T_2 draws a very heavy current as it turns on and thus both the cathode of T_2 and T_1 are caused to rise. In fact, the cathode of T_1 rises, above the grid potential of T_1 , which is held by C_2 charging up through R_2 and thus T_1 begins to turn off. The plate of T_1 then rises rapidly until the grid of T_2 catches on the zener diode and continues to rise as C_1 charges through R_7 towards 300 volts. The tube T_2 is now turned fully on and its cathode potential is at a positive value determined by the zener diode and its plate has dropped to some value below 225 volts determined by R_5 . At the same time, however, the grid of T_1 rises as C_2 charges through R_2 towards the cathode potential of T_2 . As the grid rises T_1 begins to turn on again causing the plate voltage of T_1 and the grid voltage of T_2 to drop. Thus T_2 begins to turn off and both the cathode potential of T_2 and T_1 drop so that T_1 is again turned fully on. In this condition the plate of T_1 bottoms and the grid of T_2 drops to a negative value to begin charging again towards 225 volts through R_1 .

The repetition rate of this circuit is determined by two factors, the charging time constant R_1C_1 and the voltage through which C_1 must charge before T_2 turns on. The voltage through which C_1 must charge is determined by the amount to which it is discharged through R_7 when T_1 is turned off. Thus if a slow repetition rate is desired the time constant R_1C_1 must be large and that of R_7C_1 must be small.

The length of pulse is controlled by the time constant R_2C_2 which determines the time at which T_1 begins to turn on again. Thus R_2 is made variable so the pulse length can be adjusted to gate one oscillation from the oscillator.

The pulse output is a negative going pulse from the anode and a positive going pulse from the cathode of T_2 , when T_2 is turned on. The amplitude of the positive pulse is set by the voltage of the zener diode. Both pulses have low impedance sources so that even under considerable loading, the pulse amplitude is maintained.

3. Oscillator

The oscillator is required to supply a constant frequency, variable amplitude sine wave. The circuit designed for this purpose is shown with waveforms in Fig. 13.

A tube is used to switch a preset amount of current into an L-C tank circuit. This causes the circuit to oscillate at its resonant frequency. If the current is turned off after exactly one cycle has been completed the oscillations produced from then on will be very small as shown in Fig. 13. The amplitude of the oscillation produced by this circuit is determined by the amount of current switched into it by the tube. The output voltage of the oscillator as shown in Fig. 13 is of the form:

$$V = |X| \sin 2\pi ft,$$

and from this $\frac{dv}{dt} = |X| 2\pi f \cos 2\pi ft =$

When $t = 0$ $\frac{dv}{dt} = |X| 2\pi f$ and $|X| = \frac{dv/dt}{2\pi f}$.

But when $t = 0$, all the current supplied by the tube is charging the capacitor C_2 , thus

when $t = 0$ $V = \int \frac{i}{C_2} dt$ and $\frac{dv}{dt} = \frac{i}{C_2}$.

Where i is the current switched into the tank circuit by the tube .

Then $|X| = \frac{i/C_2}{2\pi f}$.

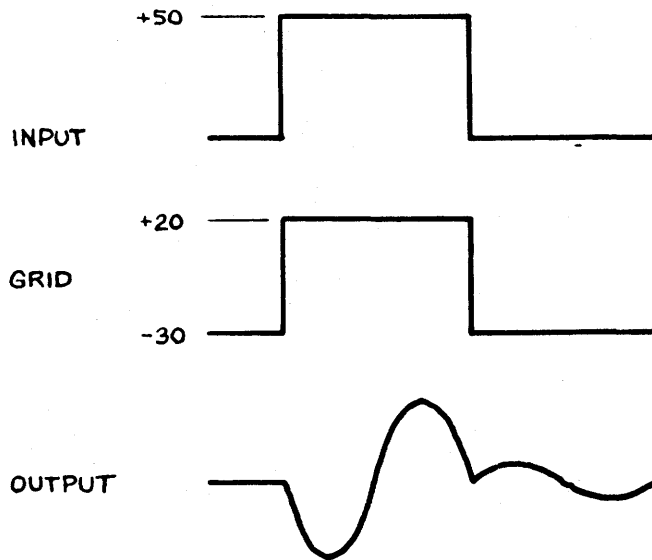
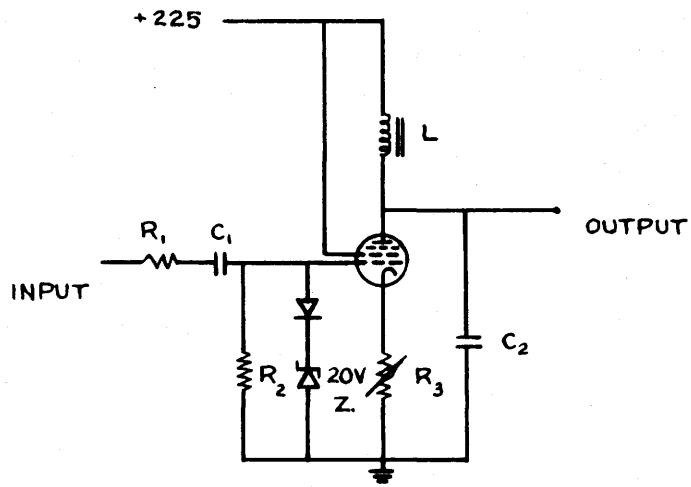

Figure 13 - Oscillator circuit

But in a resonant circuit

$$2 \pi f = \frac{1}{\sqrt{LC_2}}$$

hence $X = i \sqrt{\frac{L}{C_2}}$.

This shows that the amplitude of oscillation is directly proportional to current supplied to the resonant circuit.

To fix the current switched into the oscillator circuit, a clamping circuit to ensure a stable amplitude gating pulse, and a cathode follower are used. A positive pulse from the pulse generator is applied to the input of the circuit. This causes the grid of the tube to rise until it is caught on the zener diode clamp. R_1 and C_1 are arranged to have a time constant in the order of forty microseconds to ensure that current continues to flow through the zener diode during the full pulse period, thus maintaining a constant amplitude pulse on the grid. Except for the grid-base voltage, the cathode of the tube will be at the same potential as the grid and hence by setting the value of R_3 the current in the tube and oscillator can be very accurately determined. Since the amplitude of oscillation is dependent on the current switched into the tank circuit, R_3 is a direct control of amplitude.

When the oscillator has completed one oscillation the pulse input switches the tube to the cutoff state. As mentioned before the oscillator continues to oscillate after this but with a low amplitude damped wave. The damping of the oscillator is set by the input to the integrator and is chosen to insure that all oscillations have ceased before the next is required.

4. Integrator

The purpose of the integrator is to take the output of the oscillator and perform a negative integration to give the required cosine wave. Thus if the output of the oscillator is

$$- X \sin 2 \pi f t$$

that of the integrator should be

$$- \int - X \sin 2 \pi f t = - \frac{X}{2 \pi f} \cos 2 \pi f t.$$

In order to elevate this curve to a form

$$\frac{X}{2 \pi f} (1 - \cos 2 \pi f t)$$

it is necessary to choose a suitable zero axis.

The circuit designed to perform this operation is shown together with waveforms in Fig. 14. The principle of operation of the circuit is as follows. Input A to the integrator is a negative going pulse from the pulse generator which is, of course, coincident with the single oscillation input B from the oscillator. The purpose of input A is to turn the integrator on during the period of a single oscillation at input B and to turn it off when the period is over. In this way none of the oscillations after the first cycle are allowed to enter the integrator. When input A is at 225 volts a current flows through R_3 , D_1 , D_2 and R_7 which is sufficient to swamp out the effects of any current which may flow to the grid of T_1 from input B. Thus the integrator is held in its stable position and any integration is inhibited. When input A drops negatively, however, R_1 and R_3 become a voltage divider such that the anode of diode D_1 is caused to drop negatively with respect to the grid of T_1 and thus

the inhibiting current to the integrator ceases. The integrator is now on and any negative signal appearing at input B can effect the grid of T_1 . If the grid of T_1 goes slightly negative the plate goes positive and the cathode follower of T_2 follows it. This reverse biases the diode D_2 and all current flowing through R_2 must then charge the capacitor C_3 .

The value of capacitance C_3 is chosen so that for any function to be integrated by the circuit the cathode follower T_2 , follows the plate movements of T_1 without significant attenuation. If the gain of T_1 is $-G$, then for a small change in the grid voltage of T_1 a change of $-G$ times as much is caused at the plate and output of the cathode follower. The voltage appearing across the capacity C_3 is then $G + 1$ times the change in grid voltage and thus the effective capacity of C_3 at the grid of T_1 is increased to $(G + 1)C_3$.

Since at the frequency used the impedance of R_2 is much greater than that of $(G + 1)C_3$, the current i flowing in R_2 is proportional to the input voltage e at B and is used in charging the effective capacity $(G + 1)C_3$. Hence the voltage change at the grid of T_1 will be:

$$\begin{aligned} V_{g1} &= \int \frac{i}{(G+1)C_3} dt \\ &= \int \frac{e/R_2}{(G+1)C_3} dt \\ &= \frac{1}{(G+1)C_3 R_2} \int e dt . \end{aligned}$$

The output voltage V_0 is, of course, simply $-GV_{g1}$

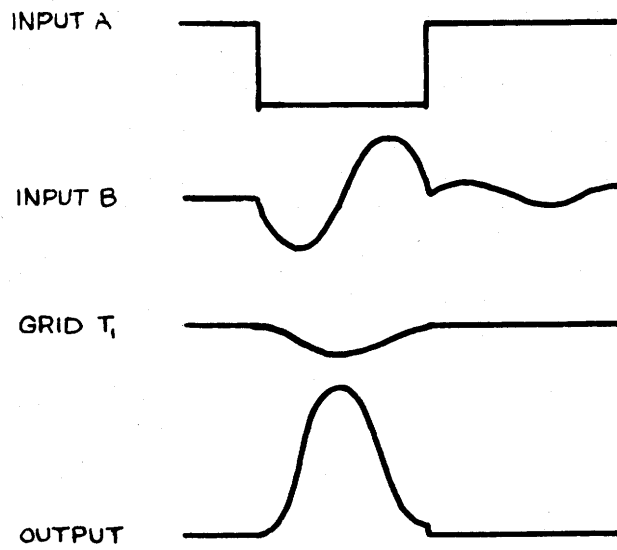
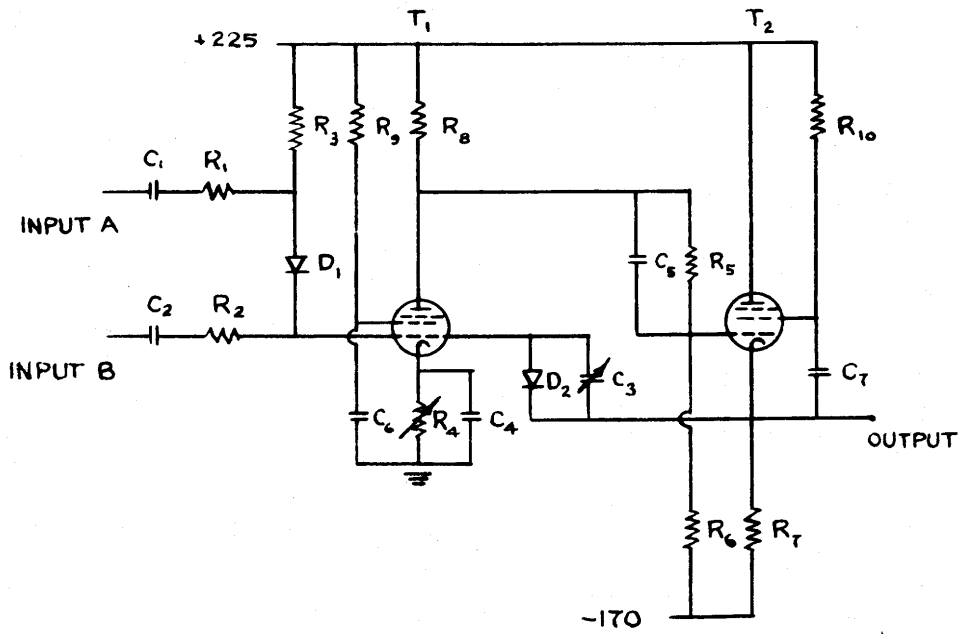

Figure 14 - Integrator circuit

Hence

$$V_0 = \frac{-G}{(G+1)R_2 C_3} \int e dt$$

and if $G \gg 1$

$$V_0 = \frac{-1}{R_2 C_3} \int e dt$$

It can be seen at once that this is the required negative integral, the amplitude of which is dependent on the values of R_2 and C_3 . R_2 is chosen to give proper damping to the oscillator circuit and then C_3 is adjusted to give the amplitude output desired.

The stable state of the circuit is determined by the voltage divider R_5 and R_6 in the grid circuit of T_2 . It must be designed so that in the stable state the plate potential of T_1 is low enough to permit the amplitude of upward swing desired at the output without cutting off the tube. It is also desirable to have the output at ground potential in the stable state but since a small negative voltage is required on the grid of T_1 to maintain it at the proper point a small resistor R_4 must be placed in the cathode circuit to raise the cathode potential. If the cathode potential is positive the circuit can operate in its stable state with the grid at ground potential.

If the input voltage e at B is $-X \sin 2\pi ft$ then the output of the integrator is:

$$\frac{-X}{R_2 C_3 2\pi f} \cos 2\pi ft.$$

And with ground potential as the zero reference as shown in Fig. 14 the output becomes:

$$\frac{X}{R_2 C_3 2\pi f} (1 - \cos 2\pi ft)$$

This is the cosine wave desired where

$$A(1 - \cos \frac{\pi}{T} t) = \frac{X}{R_2 C_3 2\pi f} (1 - \cos 2\pi ft)$$

So that $A = \frac{X}{R_2 C_3 2\pi f}$

and $T = \frac{1}{2 f}$

5. Exponential Control

The exponential control is required to affix an exponential with limited variability to the elevated cosine output of the integrator. The circuit designed for this purpose is shown with wave forms in Fig. 15.

The exponential control circuit functions as follows. When a positive going waveform is applied to the input of the circuit, the diode conducts and causes the voltage across R and C₀ to rise in the same manner as the applied waveform. When the waveform begins to go negative the voltage across R and C₀ follows it exactly as long as the waveform is falling at a slower rate than C₀ discharges through R, since then the input waveform must continue to charge C₀ or the voltage across R and C₀ would drop below the input voltage. However when the input waveform begins to fall at a faster rate than C₀ discharges through R the diode becomes reverse biased and the output is then the exponential of C₀ discharging through R. Thus an exponential of time constant R C₀ begins when the negative rate of change of the input voltage is equal to the negative rate of change of the R C₀ discharging exponential. The mathematical considerations of this have been discussed previously.

The exponential time constant is R C₀ and thus the required

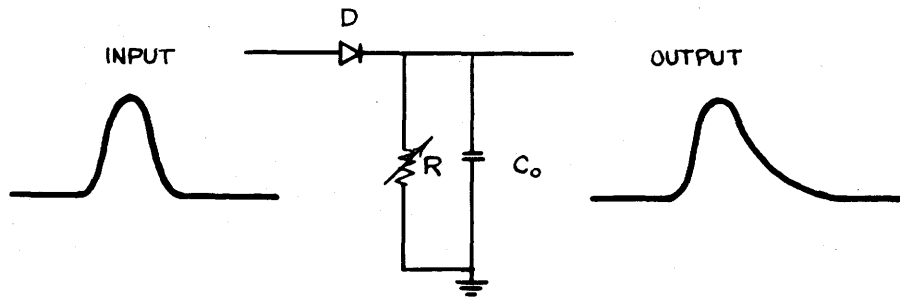
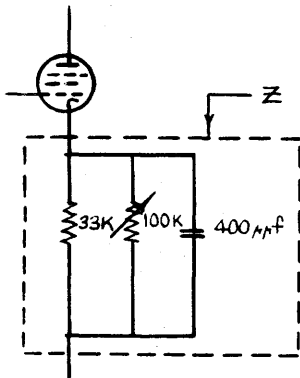

Figure 15 - Exponential control circuit



C_0	R	Z
0.5	25K	14.1K $\angle 5^\circ$
0.7	35K	16.9K $\angle 6^\circ$
1.0	50K	19.9K $\angle 7^\circ$
1.5	75K	22.7K $\angle 8.2^\circ$
2.0	100K	24.5K $\angle 8.8^\circ$

Table V - Impedance Z as a function of C

variation of time constant can be obtained by making R variable. If R is chosen so that when it is half in the time constant is equal to the half period of the cosine wave T, then the C of the exponential time constant CT becomes a linear function of R with a range of values from zero to two. The values of R and C₀ are chosen so that the above condition exists and so that they do not present an excessive load to the cathode follower output of the integrator. The impedance of this circuit for various values of C using a 100 K potentiometer and 400 $\mu\mu\text{f}$ capacitor is tabulated in table V.

A trimmer calibration capacitor is paralleled with the capacitor C₀ to allow for adjustment of the time constant with respect to R. The necessity of this adjustment will be made clear when calibration of the computer is discussed.

6. Sweep Generator

The sweep generator must provide a sawtooth voltage governed by two constraints. First the sawtooth must be compatible with the requirements of a Tektronix type 360 Indicator and secondly it must provide a range of sweep rates which will give the required range of period to the visual display of the generated curve.

To be compatible with a Tektronix type 360 Indicator the sweep generator must supply a sawtooth with amplitude between 110 and 150 volts and with extreme values no less than -90 volts or no greater than +170 volts. A positive fifty volt unblanking pulse is also required during the sweep period.

If a 120 volt sawtooth gives a full three inch sweep on the indicator and this is doubled by the optical system to be described later,

this length compares to one and one half periods of the longest period concentration curve. In order to have one and one half periods of the generated curve on the trace the sweep must be complete in 1.5×40 microseconds or 60 microseconds. Thus the fastest sweep rate required for a 120 volt sweep is 2 volts per microsecond. The shortest period concentration curve corresponds in the same manner to one inch per period or six periods to a sweep on the magnified indicator trace. Thus a 240 microsecond sweep is required to make the generated curve compare. This sets the slowest sweep rate at one half volt per microsecond. The sweep must, of course, be continuously variable between the fastest and slowest rates.

The circuit designed to meet these requirements is shown together with waveforms in Fig. 16. T_2 and T_3 form a "bootstrap" circuit which is switched on and off by T_1 .

The operation of the sweep generator is as follows. In the circuit's stable state the grid of T_1 is at a negative potential set by the voltage divider R_2 and R_3 and thus T_1 is turned off. The plate of T_1 is thus at a high positive potential which holds the grid of T_2 positive and bottoms T_2 on the voltage regulator tube OB2. Since the cathode potential of T_2 is about -65 volts as set by OB2, the tube T_2 bottoms at some voltage below ground and thus draws current through D_6 which is held at ground by the forward conduction of the 120 volt zener. The grid and, for practical purposes, the cathode of T_3 are thus at ground potential, but to maintain the grid of T_3 at ground potential T_2 must also draw current through the 50 volt zener, and R_{15} , thus causing 100 volts to appear across R_{15} and the capacitor C_4 .

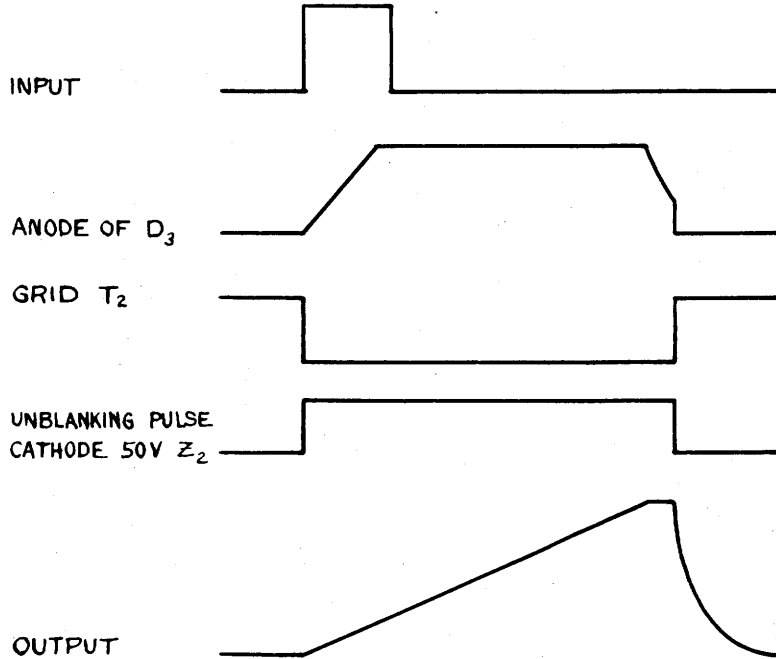
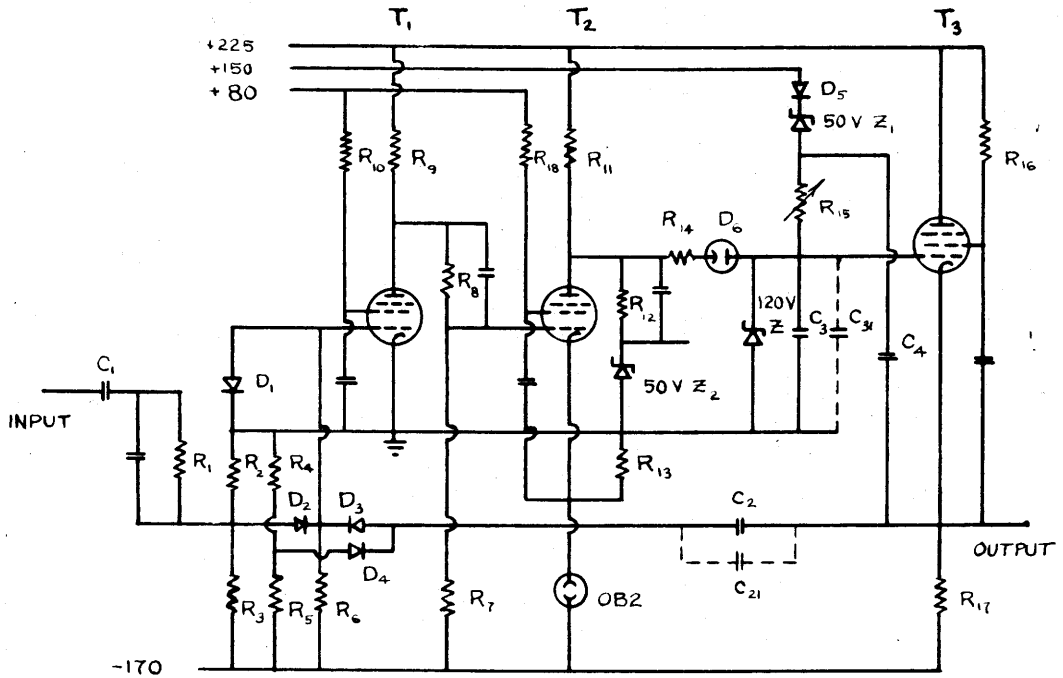
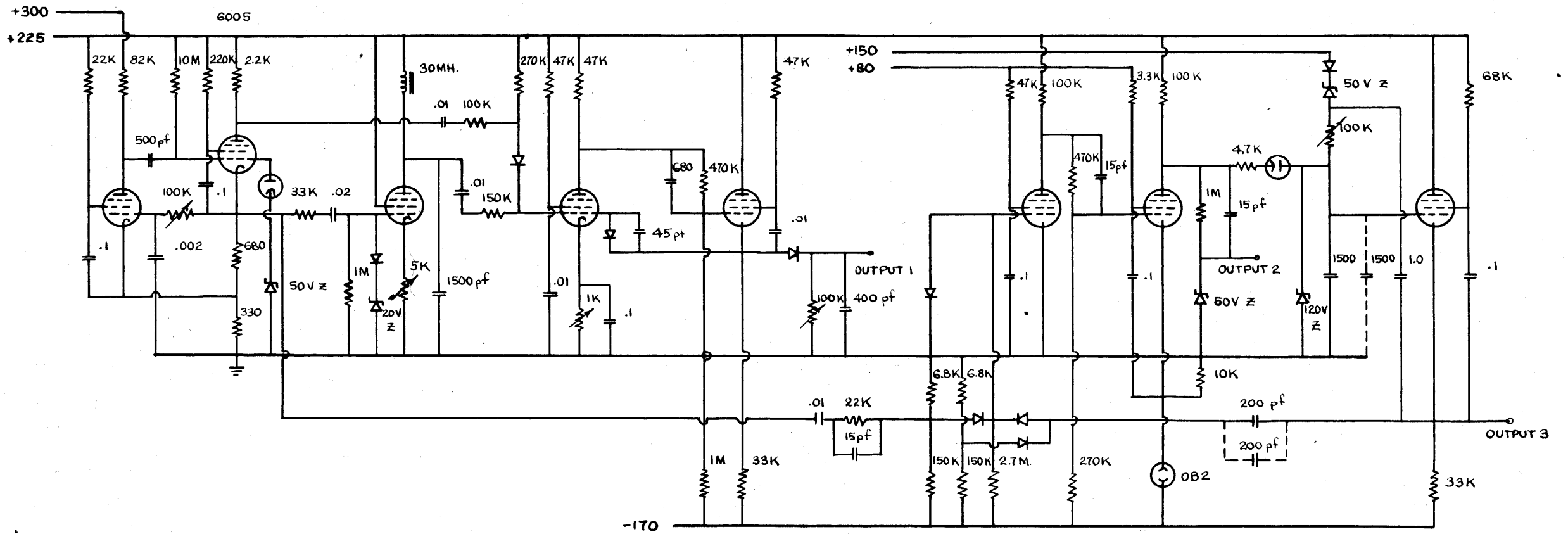

Figure 16 - Sweep generator circuit

A positive pulse from the pulse generator applied to the input of the circuit causes the grid of T_1 to rise and the plate of T_1 bottoms. The grid of T_2 thus drops negatively causing T_2 to turn off. The plate of T_2 then rises rapidly causing the 50 volt zener₂ to conduct and produce a 50 volt unblanking pulse and causing the diode D_6 to become reverse biased. No current can now flow through D_6 but the capacitor C_4 continues to maintain 100 volts across R_{15} . The current through R_{15} must then charge C_3 which causes the grid and cathode of T_3 to rise. C_4 is chosen very much larger than C_3 so that no appreciable voltage drop appears across C_4 as C_3 charges and thus the charging current through R_{15} is maintained constant. With a constant charging current the voltage on C_3 and thus the voltage of both the grid and cathode of T_3 rise linearly until the grid is caught on the reverse conduction of the 120 volt zener.

The input pulse from the pulse generator is always shorter than the sweep length, hence a feedback capacitor C_2 is placed in the circuit which will supply sufficient current to the grid of T_1 even at the slowest sweep rate to keep T_1 turned on. When the sweep is caught on the 120 volt zener, however, C_2 discharges through R_6 until caught on the diode D_4 at a negative potential set by the voltage divider R_4 and R_5 . T_1 is thus turned off, T_2 is turned on, the unblanking pulse drops to zero and the capacitor C_3 discharges through R_{14} until caught on the forward conduction of the 120 volt zener. The circuit has thus been returned to its stable state.

Small capacities are placed in parallel with resistances R_1 , R_8 and R_{12} to increase the speed of the circuit. Since the same pulse used to start the sweep generator initiates the curve generation, no long



All tubes are 6136's except the one marked 6005
 Thermionic diodes are 6919's
 All other diodes are silicon HR10211
 Output 1 - curve output
 Output 2 - unblanking pulse
 Output 3 - sawtooth

Figure 17 - Complete curve generator circuit

delay in between the pulse and the beginning of the sweep can be tolerated.

The circuit is designed with two sweep ranges which together give the range of sweep rates required. Capacitors C_{21} and C_{31} are switched in to half the sweep rate. This arrangement is required to keep the range of R_{15} high and thus limit the current requirements of tube T_2 during the stable state and of T_3 during the sweep generation. Small calibration capacitors must also be included in parallel with C_3 and C_{31} to allow for recalibration if the 50 volt zener is replaced or if one sweep rate is not exactly twice the other.

This circuit provides a sawtooth of 120 volt amplitude between zero and +120 volts with the required range of sweep rate determined by the values of R_{15} and combinations of C_3 and C_{31} . The sweep rate is continuously variable and is controlled by the resistance R_{15} .

7. Optical System

The indicator concentration curve is traced out continuously by a galvanometer which reflects a light beam onto instantly developing photographic paper. The photograph thus obtained must be compared visually with the generated curve of the cardiac output computer. To do this an optical system is required which will either enlarge the oscilloscope image, since it is too small to be compared directly, or reduce that of the indicator concentration curve and then superimpose the images of the generated curve and the actual curve.

Since an optical system using virtual images is compact and increases the image size making the optical fit easier, this type of system was chosen. The optical system is shown in Fig. 18. It consists of a front silvered mirror; a 128 millimeter diameter, 340 millimeter

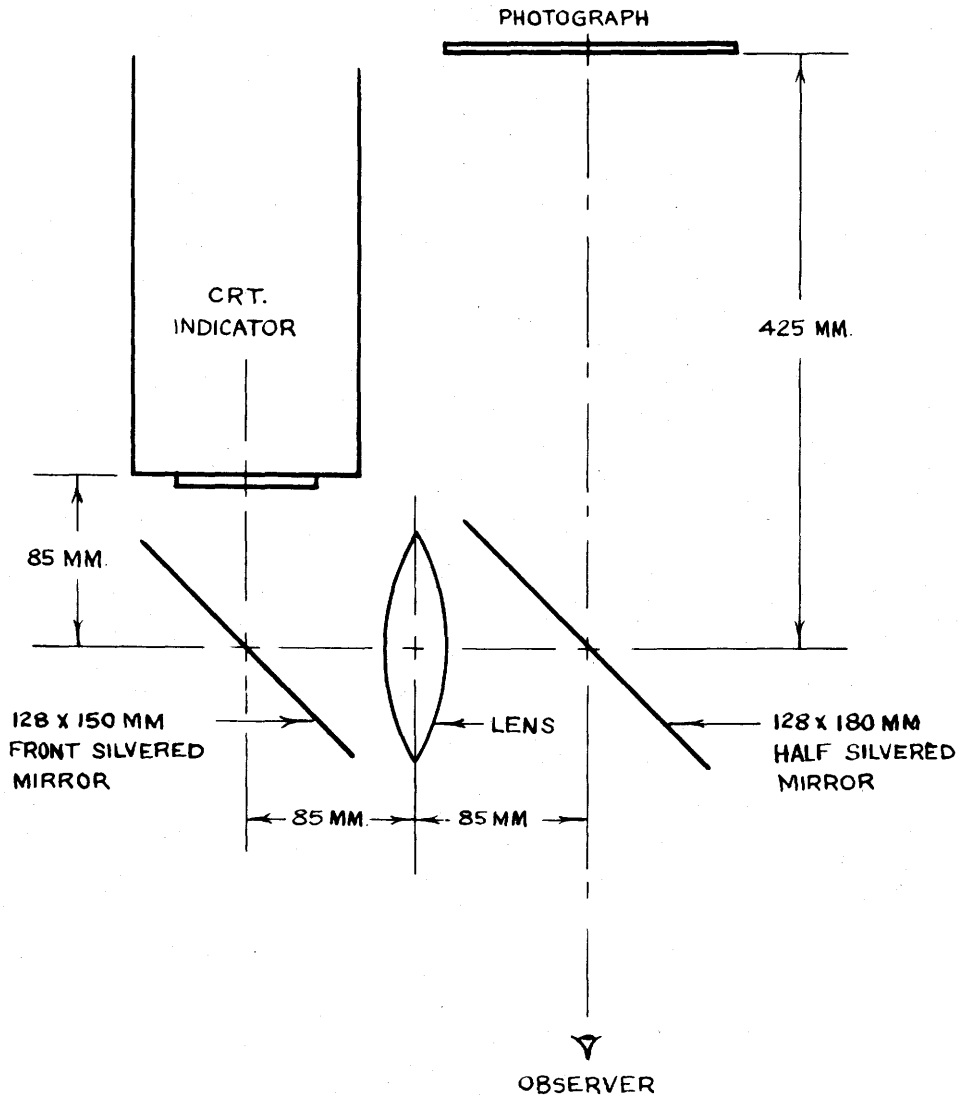

Figure 18 - Optical system

focal length lens and a half silvered mirror.

The lens system shown doubles the visual size of the generated curve, which gives a convenient range of size for exactly duplicating the indicator concentration curves.

To make the image virtual and double the object size requires that the lens be positioned with respect to the object in accordance with the following formula.

$$\frac{1}{p} - \frac{1}{q} = \frac{1}{f} .$$

Where p is the distance from the lens to the object, q is the distance from the lens to the image and f is the focal length of the lens. To have the image size double the object size the image distance q must be twice the object distance p . Hence for the lens in this system

$$\frac{1}{p} - \frac{1}{q} = \frac{1}{p} - \frac{1}{2p} = \frac{1}{f} = \frac{1}{340 \text{ mm}} .$$

Thus $p = 170 \text{ mm}$.

This then is the required distance from the lens to the oscilloscope trace as indicated in Fig. 18. The front silvered mirror is required to swing the optical axis through 90° and has no effect on the lens to object distance.

The half silvered mirror is placed arbitrarily 85 mm from the lens but if the image of the generated curve as viewed in the half silvered mirror is to coincide with the indicator concentration curve seen through the mirror, the distance from the mirror to the image of the generated curve must equal the distance from the mirror to the indicator concentration curve. Adding the distance from the mirror to the lens, to that

from the lens to the virtual image, then gives the required length between the mirror and the actual trace. This is indicated in Fig. 18 as being 425 mm.

The position of the lens must, of course, be made accurately since the calibration of the computer is affected by the lens multiplication factor.

The position of the indicator concentration curve must be adjustable to enable the operator to eliminate any parallax in the optical system.

The photographed curve may be illuminated by a variable intensity light of a color which will give greatest visual contrast to that produced by the oscilloscope and thus aid the operator in obtaining a good fit.

8. Calculator

When the operator has fitted a curve optically all the parameters necessary for the determination of cardiac output and mean transit time are theoretically available. However, the determination of cardiac output involves the multiplication and division of these factors according to the Stewart-Hamilton equation.

$$CO = \frac{IM}{K_g AT}$$

Since these factors are almost linear functions of the curve parameters a calculator can be coupled directly which will calculate the above type of mathematical expression .

The type of calculator to be used in this computer is shown in Fig. 19(a). It is a simple linear calculator and operates on a null

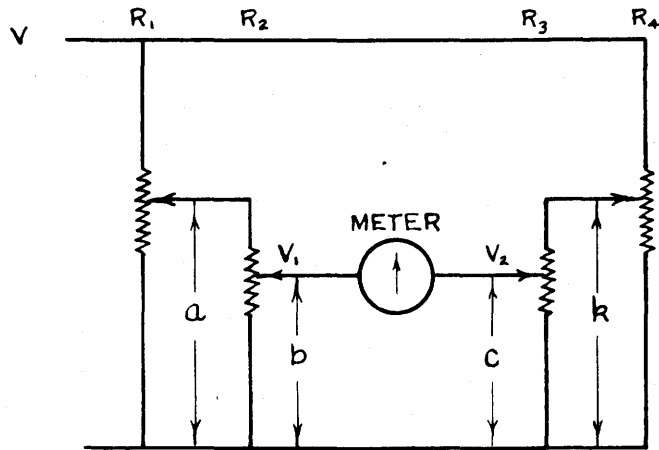

(a) Simple calculator circuit

a	ERROR
0	0 %
0.1	0.09
0.2	0.16
0.3	0.21
0.4	0.24
0.5	0.25
0.6	0.24
0.7	0.21
0.8	0.16
0.9	0.09
1.0	0

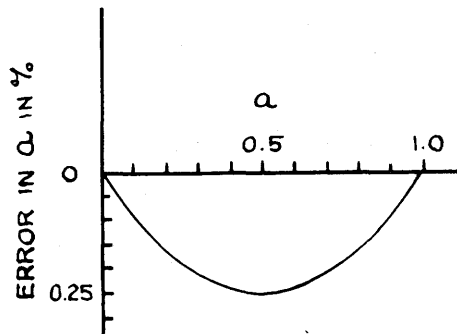

(b) Error curve of "a" for $R_2:R_1 = 100:1$

Figure 19

detection system to balance two fractional voltages.

To simplify the discussion of the performance of the calculator, assume that the potentiometer R_2 does not load R_1 and similarly R_3 does not load R_4 . Then if a , b , c and k represent fractional parts of the rotation of the associated linear potentiometers, the voltage across R_2 becomes a fractional part of V determined by the setting, a , of R_1 and is equal to aV . Similarly the voltage V_1 becomes a fractional part of the voltage aV determined by the fractional setting of R_2 and is equal to abV . The same is true of the right hand side of the calculator where the voltage V_2 is equal to ckV . Now if a , b and c are set at some fractional values the value of k can be adjusted until the voltage V_1 is equal to V_2 or a null is obtained.

$$\text{If } V_1 = V_2$$

$$\text{then } abV = ckV$$

$$\text{and } ab = ck$$

$$\text{or } k = \frac{ab}{c} .$$

Thus the fractional setting, k , of R_4 is the quotient of a fractional number c and the product of two fractional numbers a and b . Since any number can be expressed as a fraction multiplied by a power of ten this circuit can be used to calculate any quotient of a number c and the product of two numbers a and b providing the answer is multiplied by the appropriate power of ten.

The assumption that R_2 does not load R_1 is a valid approximation if R_2 is much larger than R_1 . However practical considerations limit the ratio of $R_2:R_1$ to 100:1 and this results in an error dependent on the setting of R_1 . Nevertheless as shown in Fig. 19(b) this error does not exceed 0.25 per cent.

In determining cardiac output and mean transit time a system of these simple calculators will be used as illustrated in Fig. 20 and 21(a). Since as already pointed out the parameters of the curve have an essentially linear effect on both cardiac output and mean transit time in the regions of interest, the parameter controls can be coupled directly to the calculator thus making the calculator operation almost direct.

The same meter as shown in Fig. 21(a) is used in all three null detecting positions. It uses a 25-0-25 microampere meter with a 10k series resistor to give a full scale deflection for a drop across the diodes either way of 0.25 volts. This means that it will detect less than 1 microampere or a 0.01 volt difference between null points. If the total voltage used is 10 volts this gives an accuracy of detection of less than 0.1 per cent. The meter is switched from one null point to another by means of a lever switch.

The actual operation of the calculator is as follows. When a cardiac output determination is to be done the amount of indicator to be injected is set on potentiometer e, (refer to Figs. 20 and 21(a)) and the calibration sensitivity of the photo cell to the indicator in the patient's blood is set on potentiometer f. When the curve is run it is placed in the optical system of the computer and fitted visually by adjusting the three parameters of the curve which are coupled directly to potentiometers a, b and c. When this is completed all the information is in the calculator and the unknown quantities are made available by proper nulling of the calculator circuit.

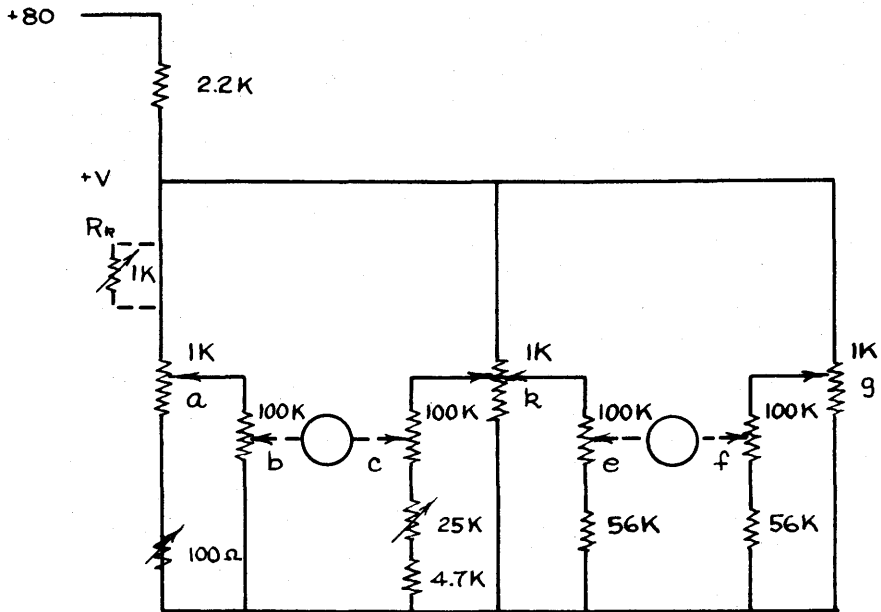

$$g = \frac{ek}{f} = \frac{eab}{fc}$$

- a = Inverse of amplitude $1/A$
- b = Inverse of half period $1/T$
- c = Constant K_A
- e = Injection I
- f = Inverse of calibration $1/M$
- g = Cardiac output $C.O.$

Hence $C.O. = \frac{IM}{K_A AT}$

Figure 20 - Cardiac output calculator

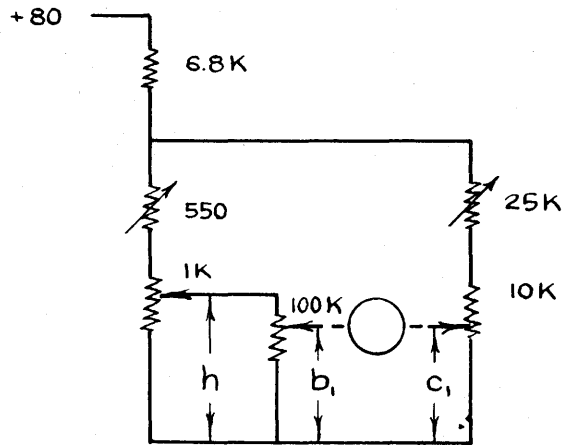

$$h = \frac{c_1}{b_1}$$

h = mean transit time T_m

c_1 = constant K_T

b_1 = inverse of half period $1/T$

Hence $T_m = K_T T$

(a) Transit time calculator

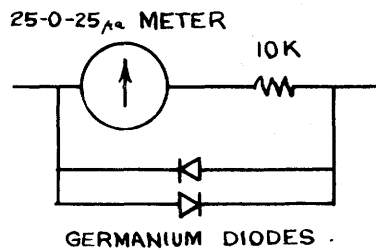

(b) Null meter

Figure 21

The first null set is the b-c null and the null meter is normally in this position. The potentiometer d is adjusted until the null meter reads zero. The null meter is then shifted to the e-f position and nulled again by adjusting potentiometer g. When the meter reads zero the cardiac output will read directly on the potentiometer scale unless the sweep has been doubled or the amplitude halved. This point will be discussed more clearly in connection with the calibration. The null meter may now be shifted to the $c_1 - b_1$ position and nulled again by adjusting h. When the meter reads zero the mean transit time will read directly on the potentiometer scale unless the sweep has been doubled in which case the number must be divided by two.

It should be noted that the b-c null must be obtained before the e-f null or the answer will be incorrect for cardiac output. However, the $c_1 - b_1$ null is independent of the other two and may be done any time after the curve has been fitted.

9. Calibration

Possibly the most important part of a computer such as that discussed in this thesis is the calibration or linking of circuit functions to some standard or scale. In this case, first of all the parameter controls of the circuit must be calibrated and linked to the calculator in such a way that the parameter values required for calculation are transferred to the calculator and secondly the output or readout elements must be calibrated accurately.

The following is a list of the parameters for determining cardiac output and mean transit time with their actual operational ranges.

Calibration	M	-	5.0 to 12 mm/mgm/L
Injection	I	-	5.0 to 12.5 mgm
Amplitude	A	-	1.25 to 5.0 cm
Half Period	T	-	2.5 to 10 seconds
Area constant	K_A	-	0.0383 to 0.0833 min/sec.
Time constant	K_T	-	1.152 to 2.508

The curve generator calibration and coupling to the calculator for parameters A, T and K will be considered first.

The amplitude A on the visual output of the curve generator is controlled by a 5K precision potentiometer, R_3 (see Fig. 14). The calibration of this control is done by setting the potentiometer at its maximum and then adjusting the feedback capacitor C_3 of the integrator (Fig. 15) until the amplitude of the output is exactly 1.25 centimeters, that is the peak to peak amplitude of the curve is 2.5 centimeters.

The amplitude setting is transferred directly to the calculator by coupling the 1K potentiometer, "a" of Fig. 20 directly to the above 5K amplitude control potentiometer. Since the output amplitude is inversely proportional to the resistance, R_3 , the input to the calculator is in the form $\frac{1}{A}$ as already considered in the calculator design.

The change, with amplitude, of grid-base voltages of the oscillator tube and integrator cathode follower, however, cause the actual $\frac{1}{A}$ versus cathode resistance curve to miss the origin as shown in Fig. 22. Since the value of $\frac{1}{A}$ is not zero when the resistance is at zero a correction must be made in the calculator so that it represents the same $\frac{1}{A}$ curve. To accomplish this a 100 ohm potentiometer is placed in series with the 1K potentiometer as shown in Fig. 20 and adjusted to lower the axis of the

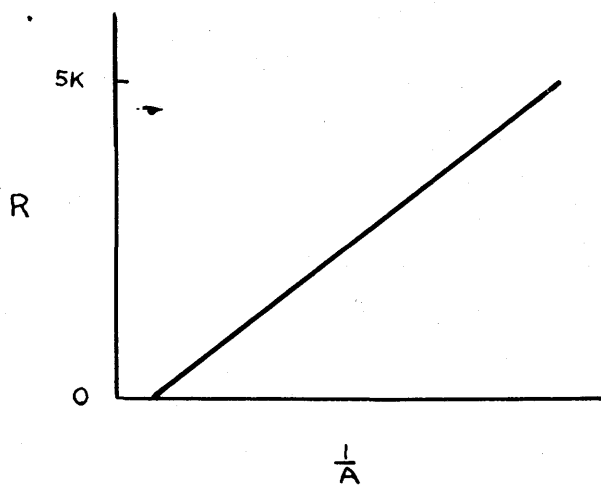

Figure 22 - Resistance versus $\frac{1}{A}$

C	ACTUAL K_A	LINEAR K_A	ERROR	ACTUAL K_T	LINEAR K_T	ERROR
0.6	2.510	2.484	1.03 %	1.255	1.242	1.03 %
0.7	2.672	2.665	0.26	1.337	1.333	0.30
0.8	2.841	2.845	0.14	1.422	1.423	0.07
0.9	3.016	3.025	0.29	1.504	1.514	0.67
1.0	3.197	3.205	0.25	1.595	1.604	0.56
1.2	3.567	3.570	0.08	1.783	1.785	0.11
1.4	3.943	3.930	0.33	1.972	1.966	0.03
1.8	4.711	4.650	1.3	2.359	2.328	1.3

Linear curves used

$$K_A = 1.4 + 1.805 C \text{ sec/sec (divide by 60 for min/sec)}$$

$$K_T = 0.7 + 0.904 C$$

Table VI - Linear values of K_A and K_T and associated errors

calculator $\frac{1}{A}$ curve, until the values coincide with the actual $\frac{1}{A}$ values generated. It is sufficient to establish coincidence at one point on the lower end of the curve since the curves are both linear.

The half period, T , is controlled by a 100K precision potentiometer, R_{15} , in the sweep generator illustrated in Fig. 17. The sweep rate is inversely proportional to R_{15} and the half period is directly proportional to the sweep rate, hence the inverse of the half period, $\frac{1}{T}$, is directly proportional to the resistance, R_{15} . The value of $\frac{1}{T}$ is transferred to the calculator by directly coupling the calculator potentiometers b and b_1 to R_{15} of the sweep generator.

Calibration of the half period T is done by adjusting trimmers on capacitors C_3 and C_{31} of the sweep generator until, when R_{15} is maximum, the visual curve has a half period corresponding to 2.5 seconds on the indicator dilution curve with C_3 and C_{31} coupled and a half period corresponding to 5 seconds with C_3 alone coupled.

With this arrangement the full range of half period T is controlled by variation of R_{15} between 0.4 and 1.0 of its value. However it should be noted that no compensation for halving the sweep rate when C_{31} is connected is provided in the calculator, hence when the sweep rate is halved by connecting C_{31} the cardiac output reading of the calculator must be doubled and the mean transit time halved.

The constants K_A and K_T are put into the calculator as linear functions of the exponential control, C , by directly coupling potentiometers c and c_1 to the 100K potentiometer, R , in the exponential control circuit of Fig. 16. In reality K_A and K_T are not true linear functions of C but in the region of interest they can be approximated very accurately by linear functions. The actual values of K_A and K_T are compared to

the values of the linear approximation to be used in table VI. It should be noted that since the normal range of C is from 0.8 to 1.2 the error is generally very small.

The actual operating range of the exponential control potentiometer to give a range of C from 0.5 to 2.0 is from 0.25 to 1.0 of its full value. When coupled to the calculator this range of potentiometer variation must represent values of K_T from 1.152 to 2.508 and of K_A from 0.0383 to 0.0833. This means that if the calculator resistances are maximum when the exponential control is maximum that the range of calculator resistances must be from 0.46 to 1 of its full value to represent the above numbers. To accomplish this using three quarters of the calculator potentiometers requires that series resistances be included as shown in Figs. 20 and 21(a). In each case the series potentiometer must be adjusted until the proper range to represent K_A and K_T is obtained.

With the ranges of a, b and c; as well as b_1 and c_1 fixed it is now necessary to check if a null can be obtained over these ranges by adjusting potentiometers d and h. Below the range of parameter operation for these functions, the range of control and calculator resistance expressed as a fraction of full resistance and the factor by which this fraction must be multiplied to obtain actual parameter values is listed.

Amplitude $\frac{1}{A}$ - 0.8 to 0.2 /cm

Resistance R_3 - 1.0 to 0.25

Resistance a - 1.0 to 0.25

Multiplying factor 0.8

Half Period for $C_3 \frac{1}{T}$ - 0.25 to 0.1 /sec.

Resistance R_{15} - 1.0 to 0.4

Resistance b and b_1 - 1.0 to 0.4

Multiplying factor 0.25

Area constant K_A - 0.0383 to 0.0833 min/sec.

Resistance R - 0.25 to 1.0

Resistance c - 0.46 to 1.0

Multiplying factor 0.0833

Time constant K_T - 1.152 to 2.508

Resistance R - 0.25 to 1.0

Resistance c_1 - 0.1152 to 0.2508

Multiplying factor 10.

The range of d is thus set by the expression $d = \frac{ab}{c}$ which gives values from 0.1 to 2.18. But potentiometer d cannot be greater than one times its own value so a halving potentiometer R_k is introduced which may be switched into the $\frac{1}{A}$ circuit of the calculator if a null cannot be obtained on d. This will give a range of d up to 2.0 which is sufficient range since the extreme of 2.18 is highly improbable. It should be noted however that when the halving resistance R_k is switched in, the cardiac output reading must be doubled and if both the halving resistance and half sweep rate capacitor are switched in, the cardiac output must be multiplied by four. In normal ranges of operation neither of these extending controls is used.

The range of h is set by the expression $h = \frac{c_1}{b_1}$ which gives values from 0.1152 to 0.625 with a multiplying factor of 40 to convert it to mean transit time. By placing a resistor in series with potentiometer h and adjusting it so that when h is maximum the output represents the fraction 0.625, the full scale reading of the transit time calculator will be 25 seconds.

The second part of the cardiac output calculator is not dependent upon the parameters of the curve and is used to enter the calibration of blood-dye concentration and the amount of injection into the calculator. For convenience the blood-dye calibration is entered as a reciprocal.

The ranges of the potentiometers used for these parameters are chosen to give a reasonable range on the cardiac output scale and to keep the components of the calculator compatible. The following is a list of the parameter ranges and corresponding potentiometer ranges chosen with multiplying factors necessary to convert the resistance fractions to real units.

Potentiometer d - 0 to 1.0

Multiplying factor $\frac{0.25(0.8)}{0.0833} = 2.4$

Injection I - 5 to 12.5 mgm

Resistance e - 0.4 to 1.0

Multiplying factor 12.5

Calibration $\frac{1}{M}$ - 2.0 to 0.833 mgm/L. cm

Resistance f - 1.0 to 0.416

Multiplying factor 2.0

The range of the cardiac output potentiometer, g is then determined by the expression $g = \frac{de}{f}$ which gives values from 0 to 2.4 with a multiplying factor of 15.

It is obvious that potentiometer g cannot reach 2.4 times its own value, however, since the possibility of all extremes being met at once is remote and since if g cannot be adjusted to obtain a null the

$\frac{1}{A}$ one halving resistance can be inserted to give a null, the advantage of having an accurate cardiac output scale is more desirable than a completely compatible calculator over ranges which may never be used.

This calculator gives a full scale reading of 15 liters per minute for cardiac output which is a convenient scale since many readings are in the 10 liter per minute range. With the sweep rate halved or the one halving resistance inserted the range is doubled to 30 liters per minute and if both are used together the range is increased to 60 liters per minute. This gives a very wide range of possible readings.

V CONCLUSION

The cardiac output computer should give a quick and simple method of determining cardiac output and mean transit time from indicator dilution curves.

The curve is fitted by controlling three independent parameters and viewing the superimposed curves in an optical system which keeps the visual curves at normal size for greatest ease and accuracy in fitting. The time involved in fitting any curve and nulling the calculator should with practise be in the neighborhood of one minute, thus making cardiac output and mean transit time available in a very short time.

The accuracy of the computer is dependent to a large extent on how well the indicator dilution curve can be fitted by the elevated cosine curve. It seems probable that the error of fit for normal curves will be less than five per cent. Since the curve is visually fitted the accuracy is also dependent on how well the theoretical curve is generated and its parameters transferred to the calculator. The error of generation in this type of function generator is quite small and is due largely to the use of a damped sine wave. The error of the calculator itself may be considerable depending on the accuracy of calibration and inherent errors already discussed, but it should be less than one per cent. The inherent error of the calculator may often be self cancelling if all the 1K potentiometers are in the same range. The error of approximating nonlinear curves with linear functions is also small and is in fact opposite in sign to the inherent error of the calculator so that error compensation is again possible.

From the above consideration it appears that the error of the computer in fitting a curve and calculating the desired information will be less than seven per cent. Since the indicator dilution method itself has limits of plus or minus twenty per cent the accuracy of the computer seems reasonable.

In general the computer should provide a simple, speedy and accurate means of extracting the required information from indicator dilution curves.

REFERENCES

- 1 Best, H. C., Taylor, N. B. - "The Physiological Basis of Medical Practise" The Williams and Wilkins Company, Baltimore, Edition 6, 1955, p. 267.
- 2 Blumgart, H. L., and Weiss, Soma - "Studies on the velocity of blood flow" I-VII Journal of Clinical Invest. vol. 4, 1927.
- 3 Fox, I. J., Sutterer, W. F., and Wood, E. H. - "Dynamic Response Characteristics of Systems for Continuous Recording of Concentration Changes in Flowing Liquid" J. of Appl. Physiol. vol. 11, p. 390, 1957.
- 4 Green, H. D., et al - "Computer Technic for Indicator Determination of Mean Vascular Transit Time" Fed. Proc. vol. 18, p. 59, 1959.
- 5 _____ - "Use of Indicator Concentration Curves in Computation of Mean Rate of Flow and Volume of Blood Contained within a Segment of the Vascular System" I. R. E. Trans. on Med. Electronics, vol. ME-6, no. 4, pp. 277-282, Dec. 1959.
- 6 Grollman, Arthur - "The Determination of the Cardiac Output of Man by the Use of Acetylene" The Am. J. of Physiol. vol. 88, p. 432, 1929.
- 7 Hamilton, W. F., et al - "Comparison of the Fick and Dye Injection Methods of Measuring Cardiac Output in Man" Am. J. of Physiol. vol. 153, p. 309, 1948.
- 8 _____ - "Studies on Circulation" I Injection Method, The Am. J. of Physiol. vol. 89, p. 322, 1929.
- 9 _____ - "Studies on Circulation" IV Further Analysis of injection method and of changes in hemodynamics under physiological and pathological conditions, Am. J. Physiol. vol. 99, p. 534, 1931-32.
- 10 _____ - "Simultaneous Determinations of the Pulmonary and Systemic Circulation Times in Man and of a Figure Related to Cardiac Output" Am. J. of Physiol. vol. 84, p. 338, 1928.
- 11 _____ - "Studies on Circulation" II Comparison of Injection Method with direct Fick Procedure, The Am. J. of Physiol. vol. 89, p. 331, 1929.

- 12 Hayden, D. T., Garret, N., and Jordan, P. - "Evaluation of Mitral Insufficiency in Dogs by Electric Analogue Simulation of Radio-isotope Dilution Data" *Circ. Research* vol. 6, p. 77, 1958.
- 13 Ingraham, R. C. - "Determination of Cardiac Output by an Improved Electrical Conductivity Method" *Fed. Proc.* vol. 8, p. 79, 1949.
- 14 Keys, J. R., Hetzel, P. S., and Wood, E. H. - "Revised Equation for Calculation of Blood Flow and Central Volume from Indicator Dilution Curves" *J. Appl. Physiol.* vol. 11, pp. 385-389, 1957.
- 15 MacIntyre, W. J. - "The Determination of Cardiac Output" Report no. NYO-2060, Western Reserve University, Cleveland, 1959.
- 16 Meier, P., and Zieler, K. L. - "On the Theory of the Indicator Dilution Method for Measurement of Blood Flow and Volume" *J. Appl. Physiol.* vol. 6, pp. 731-744, 1954.
- 17 Merriman, J. E., Wyant, G. M., Bray, G., and McGeachy, W. - "Serial Cardiac Output Determinations in Man" *Can. Anaes. Soc. J.*, vol. 5, pp. 375-383, 1958.
- 18 Newman, E. V., et al - "The Dye Dilution Method for Describing the Central Circulation" *Circulation* vol. 4, p. 735, 1951.
- 19 Parrish, D., Hayden, D. T., Garrett, W., and Huff, R. L. "Analogue Computer Analysis of Flow Characteristics and Volume of Pulmonary Vascular Bed" *Circ. Research* vol. VII no. 5, p. 746, 1959.
- 20 Seely, S. - "Electron Tube Circuits" McGraw Hill Book Company Inc., 1950.
- 21 Sheppard, C. W., - "Mathematical Considerations of Indicator Dilution Technique" *Minn. Med.* vol. 37, pp. 37-104, 1954.
- 22 Skinner, R. L., and Gehmlick, D. K. - "Analog Computer Aids Heart Ailment Diagnosis" *Electronics*, Oct. 2, 1959.
- 23 Stephenson, J. L. - "Theory of the Measurement of Blood Flow by the Dilution of an Indicator" *Bull. Math. Biophysics* vol. 10, pp. 117-121, 1948.
- 24 _____ - "Theory of Measurement of Blood Flow by Dye Dilution Technique" *I.R.E. Trans. Med. Elect.* Dec. 1958, p. 82.

- 25 Stewart, G. N. - "The Output of the Heart in Dogs" Am. J. of
Physiol. vol. 57, p. 27, 1921.
- 26 _____ - "The Pulmonary Circulation Time, the Quantity of
Blood in the Lungs and the Output of the Heart" Am.
J. of Physiol. vol. 58, p. 20, 1921.
- 27 Terman, E. F. - "Electronic and Radio Engineering" McGraw-Hill
Book Company Inc., 1955.
- 28 Willius, F. A., and Keys, T. E. - "Cardiac Classics" C.V. Mosley
Company, St. Louis, 1941.
- 29 Wood, E. H., and Swan, H. J. C. - "Definition of Terms and Symbols
for Description of Circulatory Indicator Dilution
Curves" J. Appl. Physiol. vol. 6, pp. 797-799, 1954.

