

## Microscopic Analysis of Phase Transition Effects during Benzene Sorption in MFI Type Zeolites

*Tomas Binder<sup>1</sup>, Christian Chmelik<sup>1</sup>, Jörg Kärger<sup>1</sup>, Wolfgang Schmidt<sup>2</sup>*

<sup>1</sup> Universität Leipzig, Fakultät für Physik und Geowissenschaften, Abteilung GFP, Linnéstr. 5, 04103 Leipzig, Germany, E-Mail: tomas@uni-leipzig.de

<sup>2</sup> Max-Planck-Institut für Kohlenforschung, Kaiser-Wilhelm-Platz 1, 45470 Mülheim an der Ruhr, Germany

### 1. Introduction

Adsorption of aromatic hydrocarbons in MFI zeolites has been intensively studied due to the importance of ZSM-5 and the aluminium-deficient analogue, Silicalite-1, in catalysis and separation. Applying different macroscopic techniques, e.g. gravimetric sorption isotherms, X-ray diffraction or solid-state NMR, several groups reported not only a phase transition of sorbate molecules under confinement of the zeolite lattice, but also minor changes of the framework structure itself depending on temperature and loading.

Microscopic studies of individual crystals by means of interference microscopy (IFM) and IR microscopy (IRM) now reveal deeper insights into the sorption behaviour and phase changes of the aromatic-MFI system.

### 2. Materials and Methods

The present work is mainly based on the recently established interference microscopy as a powerful tool to monitor time-dependent intracrystalline concentration profiles with a two-dimensional special resolution of  $0.45 \mu\text{m}$  [1, 2]. IFM basically detects the change of the refractive index of a large individual crystal, being directly correlated to the intracrystalline concentration of sorbate molecules.

The sample consists of large, coffin-shaped Silicalite-1 crystals with a size of  $200 \times 25 \times 25 \mu\text{m}^3$  [3]. Individual crystals are known to be generally built up from six building blocks with a  $90^\circ$  rotated intergrowth structure (fig. 1) [4]. The zigzag and straight channels are running in *a*- and *b*-direction, respectively, and the diffusion of sorbate molecules in *c*-direction is strongly hindered due to the lack of a connection in this last case.

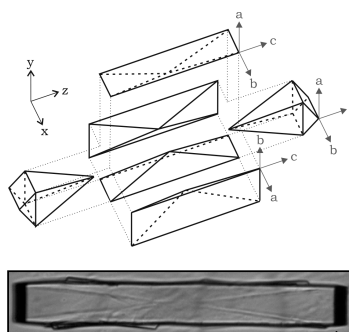

Fig. 1: Silicalite-1 crystal, top: building scheme with  $90^\circ$  rotated subunits, bottom: picture of the *x-z*-plane in normal optical mode (transmission).

### 3. Experimental Results

IFM and IRM experiments were carried out in the range from 0.1 to 100 mbar pressure of benzene. The region of interest with the clearly visible phase transition could be found between 5 and 15 mbar depending on very small changes in the surrounding

temperature. This can be related to an intracrystalline loading above 4 molecules per unit cell.

The obtained isotherm is shown in fig. 2 in comparison with gravimetric uptake data from literature [5]. The more interesting outcome of IFM experiments, namely intracrystalline concentration profiles, reveals a two-step adsorption-phase-transition behaviour when applying only one pressure step, e.g., 5 to 10 mbar. During the first minutes a common adsorption process can be identified with the diffusion front moving along

the  $a$  and  $b$  directions from the long crystal faces towards the center (fig. 3 top). Without further changes to the pressure a second step can be observed during the next two to three hours, clearly indicating a phase transition. The front of this process moves from the short crystal faces along the  $c$ -direction to the center and occurs only in the pyramidal segments first (fig. 3 bottom).

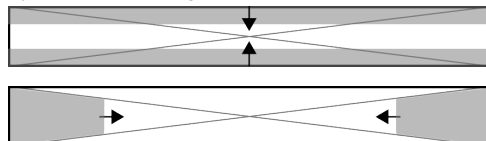

Fig. 3: Scheme of diffusion front (top) and phase transition front (bottom) after a pressure step from 5 to 10 mbar benzene.

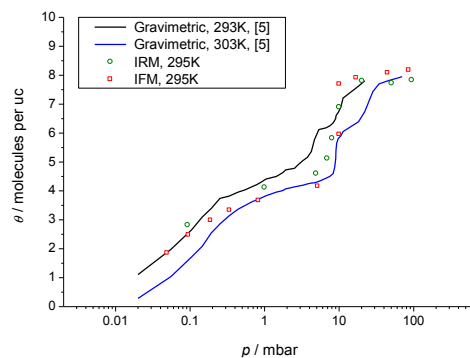

Fig. 2: IRM and IFM isotherm data compared with literature values.

Further investigations have shown a strong dependence on the applied pressure step and revealed several metastable states, in which the second step, i.e., the phase transition, occurs only in parts of the crystal.

#### 4. Conclusion and Outlook

Interference microscopy has shown to yield deep insights into the phase transition behaviour of Silicalite-1 crystals upon benzene adsorption. The present study indicates a two-step process of adsorption/diffusion and phase transition with the option to follow both the kinetics and the position dependence within an individual crystal.

#### References

- [1] T. Binder, C. Chmelik, L. Heinke, F. Hibbe, J. Kärger, T. Titze, D. Tzoulaki, *diffusion-fundamentals.org* 11 (2009) 1-17
- [2] C. Chmelik, J. Kärger, *Chem. Soc. Rev.* 39 (2010) 4864.
- [3] D. Tzoulaki, L. Heinke, W. Schmidt, U. Wilczok, J. Kärger, *Angew. Chem., Int. Ed.*, 47 (2008) 3954-3957
- [4] E. R. Geus, J. C. Jansen, H. van Bekkum, *Zeolites* 14 (1994) 82.
- [5] C.-K. Lee, A. Chiang, *J. Chem. Soc., Faraday Trans.* 92 (1996) 3445-3451.