

The Mind Agents in Netlogo 3.1

Sule Yildirim¹ Gregory L. Dam² James C. Houk³

¹Department of Computer Science, Hedmark University College, Norway, suley@osir.hihm.no

Departments of ²Learning Sciences and ³Physiology, Northwestern University, Evanston IL

g-dam@northwestern.edu, j-houk@northwestern.edu

Keywords: Mind agents, distributed processing modules, computational microscopic module

Abstract

In [Houk, 2005], the “Agents of the mind” idea is proposed as a suitable framework for studying the dynamics and complexities of mind. “Agents of the mind” is inspired by the society of mind idea of Marvin Minsky [Minsky, 1988]. According to the society of mind, the mind is a complex system. The mind agents are elusive to identify. The mind is proposed as a hierarchy of agents. The higher hierarchy agents compose of lower hierarchy agents. Higher level agents do not command lower level agents but they basically trigger or invoke lower level agents. Agents are functional entities and they interact with each other. One important part of the society of mind idea is that agents at the lowest level are the real workers. Higher level functionalities emerge as a result of the functioning of the lower level agents and the interactions between them.

In agents of the mind project, computational distributed processing modules (DPM) are posited for corresponding anatomically defined assemblies and they are referred to as the agents of the mind. M1 is an anatomical area in the cerebral cortex which produces voluntary commands via its loops through basal ganglia and cerebellum. M1-DPM is a computational distributed processing module which simulates M1 area and its loops for voluntary commands production. We use Netlogo 3.1 agent-based programming environment to illuminate the properties of mind. In this work, the attractor network in cerebellar loop and the effects of Purkinje cell on production of motor commands have been studied. The results are reported in this paper.

1. INTRODUCTION

Houk 2005 posits a framework where questions about how the mind thinks and controls actions may involve focusing on “networks of anatomically defined assemblies” that have been called distributed processing modules. This

position firstly came after a series of experiments on functional imaging during a serial order recall task [Houk et al., 2005]. These experiments were made to study human brain activity during the selection of actions from working memory. Secondly, microelectrode recordings from monkeys trained in a step-tracking task were used to study natural selection of corrective sub movements. The DPM-based model assisted in the interpretation of the collected data. Thus, such a framework is suitable for focusing on questions about how the mind works and controls actions.

DPMs are posited as agents of the mind. That means that DPMs can be at different levels of hierarchy and higher level DPMs invoke lower level DPMs. The real workers are the lowest level DPMs. DPMs are composed of loops through the basal ganglia and through the cerebellum. The basal ganglia loop is involved in pattern classification and action selection whereas cerebellum loop is involved in refining actions. In basal ganglia loop, basal ganglia receives patterns from cerebral cortex and it can receive several patterns for a particular task from cerebral cortex (**Figure 1**). It has to make a decision between those patterns or sometimes one pattern can be strong and initiate its own selection. The decided/selected pattern is further sent to the cerebellum loop for refinement and amplification. In **Figure 1**, a hierarchy of DPMs is shown. In the figure, the cortical-cortical connections between levels are also shown. In the hierarchy, at the lowest level, M1-DPM produces the voluntary motor commands and these commands are sent to the muscles. In the human brain, it is suggested that there can be on the order of 100 DPMs.

Following example can be given to explain what a DPM module could do in practice. Imagine that there is a cup on a table and a person wants to reach the cup (**Figure 2**). There is an occluding object in front of the cup. There are many paths towards the cup from where the person’s hand is although the occluding object is putting constraints on the accessibility of the cup or the number of paths. Then, the cerebral cortex can visualize two approximate paths and send them to the basal ganglia for selection of one of them.

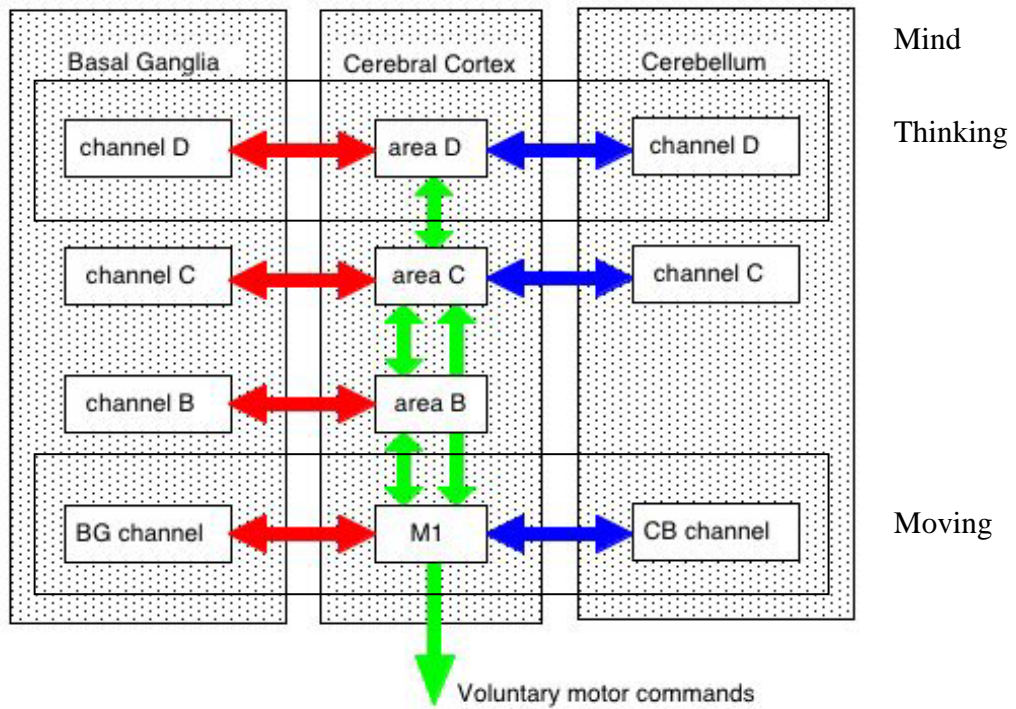

Figure 1. DPMs communicate with each other through cortical-cortical connections.

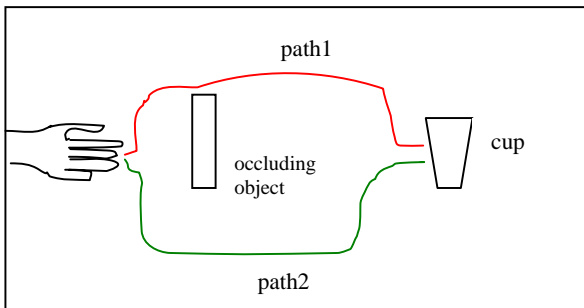

Figure 2. Two possible paths that cerebral cortex selects and sends to basal ganglia for deciding on one.

The basal ganglia, in addition and depending on the context, might also be reinforced to select the shortest one of the possible paths conveyed by the cerebral cortex to it. In that situation, the shortest path will be discovered and sent to cerebellum because of the contextual constraint posed by cerebral cortex. Cerebellum, then, estimates the tiny motions from the hand to the cup. **Figure 3** shows the pattern selection, amplification and refinement process in generating a voluntary movement. The responsible DPM is the M1-DPM.

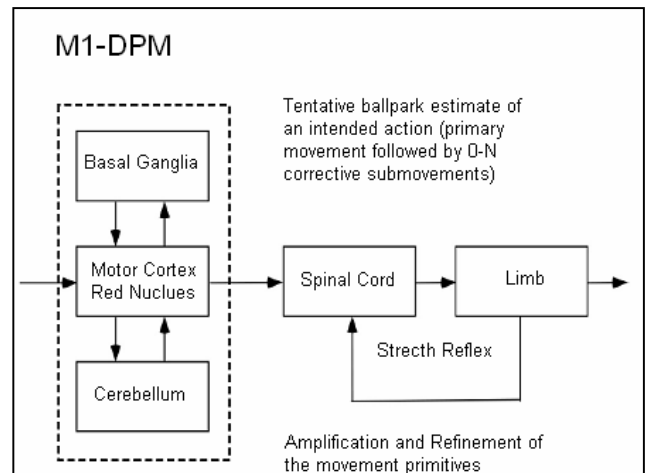

Figure 3. The pattern selection, amplification and refinement process.

2. M1 CORTICAL-CEREBELLAR LOOP

M1 cortical-cerebellar loop may especially be important in regulating the intensity and the duration of voluntary commands. Cortical-cerebellar loop forms the loop between the cerebral cortex and cerebellum. It has macroscopic and

microscopic components. In this project, we have implemented a microscopic component of an M1 cortical-cerebellar loop. The nature of macroscopic and microscopic loops will be explained in the next section.

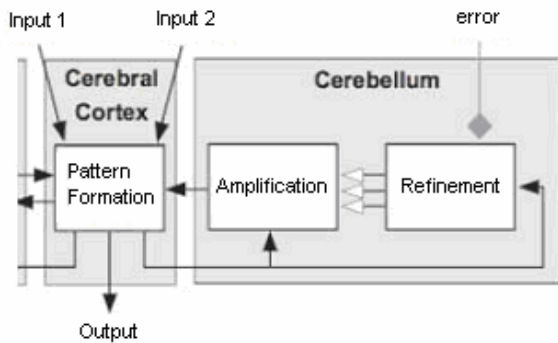

Figure 4. M1 cortical-cerebellar loop.

3. CEREBELLAR SIGNAL PROCESSING SCHEME

In **Figure 5**, one macroscopic module of cortical-cerebellar loop is given. There are two main divisions of the cerebellum: the cerebellar cortex and the cerebellar nuclei [Houk and Miller 2001]. Cerebellar cortex composes of a granular layer and a molecular layer. Mossy fiber inputs are projected into an even larger number of granular cells. The axons of granule cells then ascend into the molecular layer to form parallel fibers. The latter transmit diverge state of information to Purkinje cells (PCs) to detect and classify many different patterns of state-relevant input that may occur. The cerebral cortex sends state information to the granular layer of cerebellar cortex.

The results of each PC's processing are then transmitted to a small cluster of neurons in the cerebellar nucleus, a projection that is exclusively inhibitory. The additional roles of a Purkinje cell are:

Purkinje cell controls intensity, velocity and duration of a movement.

Bi-stability of PC: It acts like a switch that can turn on or off a motor command with also the help of a sensory cue. PC inhibits a closed loop between a cerebellar nuclei cell and a motor cortical cell where the loop is called an attractor network.

Current work simulates the sequence of initiation of an upward tiny motion by simulating a microscopic module (**Figure 6**).

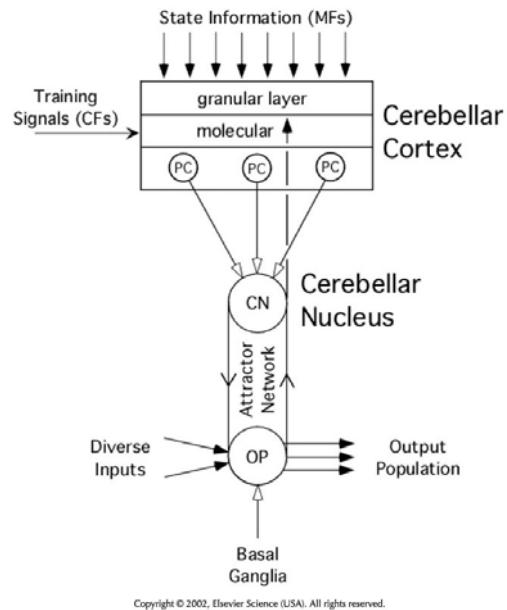

Figure 5. One macroscopic module.

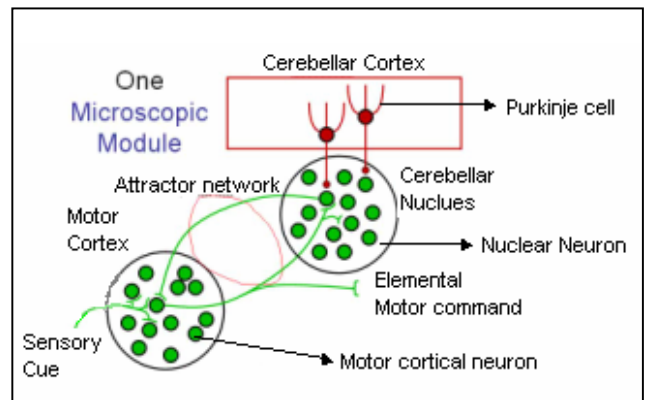

Figure 6. One microscopic module.

4. THE STATES OF THE ATTRACTOR NETWORK

The attractor network shown in **Figure 6** has two stable states that it can be drawn to depending on the firing rate of the Purkinje cell and the strength of an input signal into the motor cortical neuron in the form of a sensory cue. High state occurs when there is sustained maximum positive feedback in the attractor network and a movement is initiated. Low state occurs when there is not any positive

feedback in the attractor network and the movement stops.

In order to initiate a movement command, the following conditions should be met:

Purkinje cell inhibition is off in preparation for movement.

Sensory cue is applied into the motor cortical neuron to initiate a movement command.

When the attractor network moves into the high state, a constant velocity movement is commanded.

Figure 7 shows the signaling for a movement command initiation.

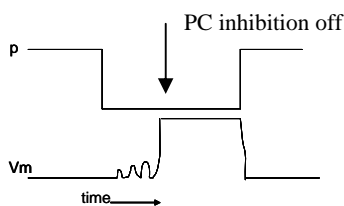

Figure 7. Signaling for a movement command initiation.

5. THE COMPUTATIONAL MICROSCOPIC MODEL IN NETLOGO 3.1

Netlogo 3.1 agent based modeling environment has been used for producing the computational model. In **Figure 8**, a microscopic model which consists of an attractor network between a motor cortical neuron (M1) and a cerebellar nuclear neuron (CN), the bias input (bb) to M1, and the Purkinje cell input (PC) is shown.

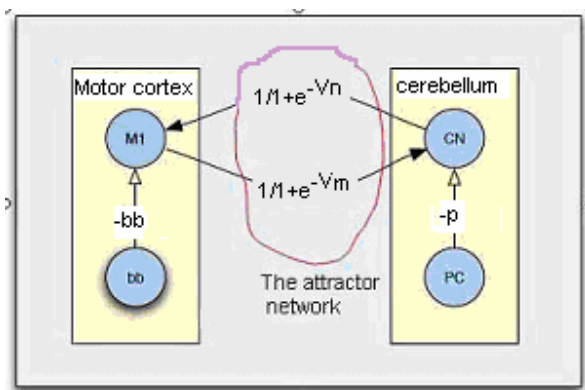

Figure 8. One computational microscopic module.

The non-linear equations which define the behavior of

the cells involved in the attractor network circuitry are formulated depending on the data collected in human [Yuen et al., 1995] and animal study experiments [Sarrafzadeh et al., 1996; Holdefer et al., 2000; Ekerot et al., 1981]. Following variables are used in the equations of the computational microscopic module:

- m: motor cortical neuron
- n: nuclear neuron
- Rm: the firing rate of neuron m
- Vm: the membrane potential of neuron m
- Rn: the firing rate of neuron n
- Vn: the membrane potential of neuron n
- T: constant time factor
- f: activation function
- w: the synaptic weight between m and n
- p: the firing rate of Purkinje cell
- bb: bias input to the motor cortical neuron

Following are the non-linear dynamical equations of the model:

$$T \frac{d(V_m)}{dt} + V_m = wR_n - bb \quad (1)$$

$$R_m = f(V_m) \quad (2)$$

$$T \frac{d(V_n)}{dt} + V_n = wR_m - p \quad (3)$$

$$R_n = f(V_n) \quad (4)$$

The attractor network has two states that it can go into: high state and low state. These states are represented in two dimensions. Vn is the x-direction and Vm is the y-direction in the two dimensional space. The network has an initial (Vm, Vn) state. This can correspond to imagining a particle in the attractor network at initial coordinates (Vm, Vn). The particle will be under d(Vm)/dt and d(Vn)/dt forces in y and x directions respectively and will move. The x and y forces are calculated by using the following equations derived from the four equations given above where f is a sigmoid activation function:

$$\frac{d(V_m)}{dt} = (wR_n - bb - V_m) / T \quad (5)$$

$$\frac{d(V_n)}{dt} = (wR_m - p - V_n) / T \quad (6)$$

$$R_m = 1 / (1 + \exp(-y_{cor})) \text{ and } R_n = 1 / (1 + \exp(-x_{cor})) \quad (7)$$

Changing the value of p will change the state of the attractor network and hence the position of the particle in the space. **Figure 9** shows the vector fields and the fixed points of an attractor network where values of p, bb and w are 5.0, 5.0 and 10.00 respectively. These values are chosen such that two states of the attractor network mentioned above can be obtained using the given sigmoid function.

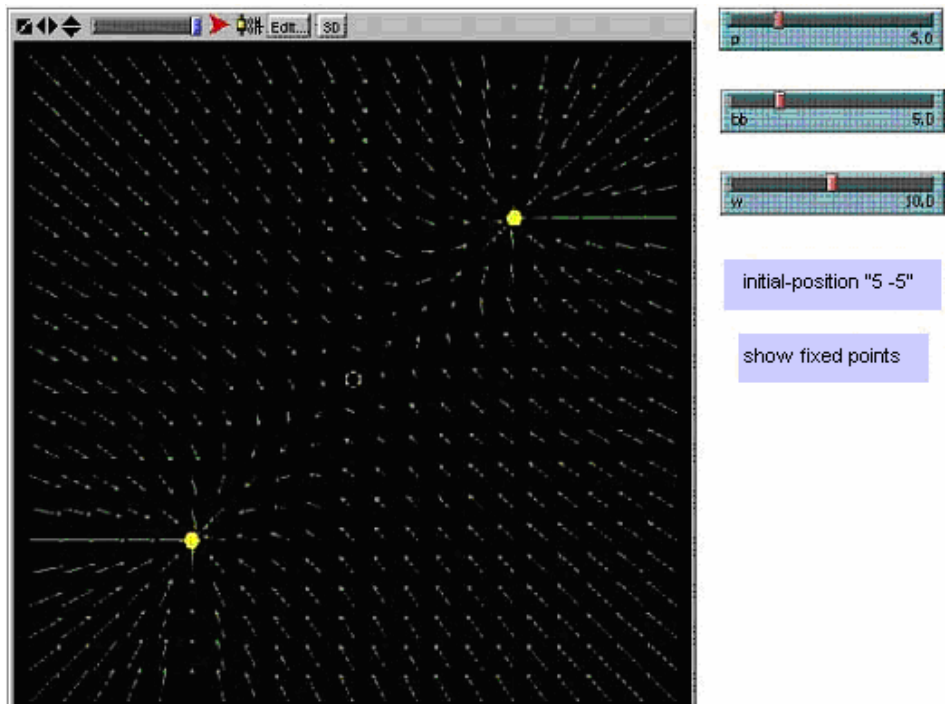

Figure 9. Vector fields and fixed points of an attractor network.

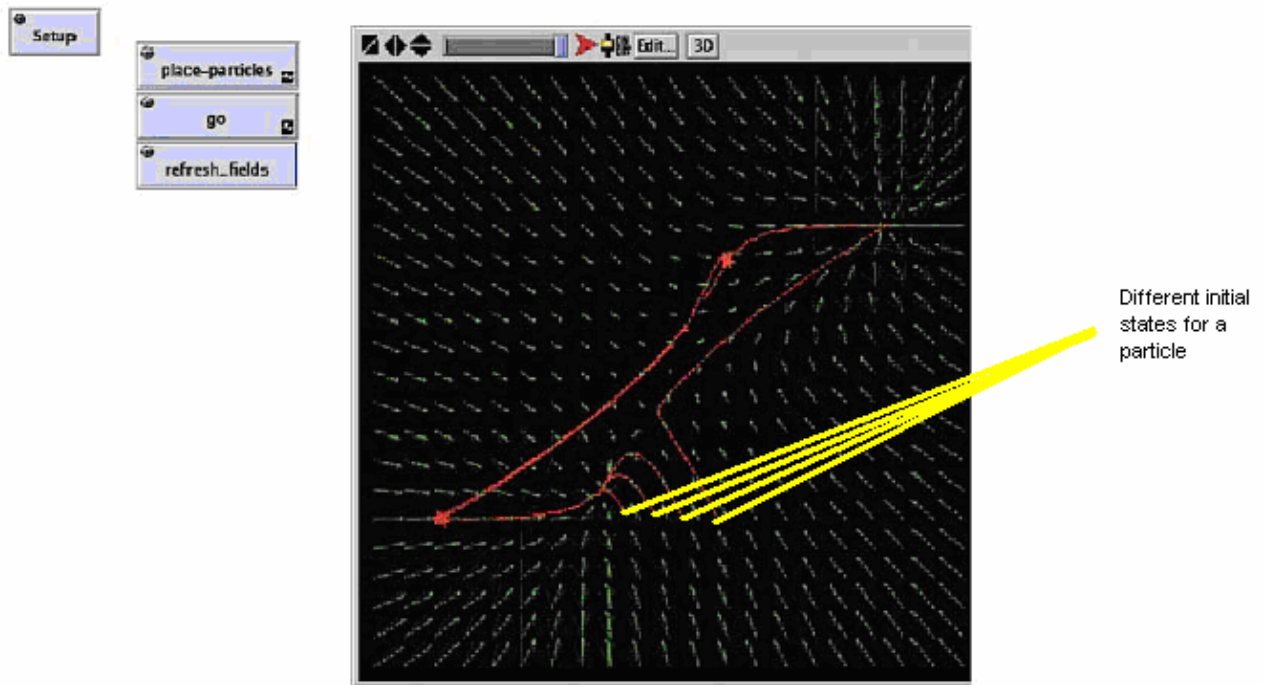

Figure 10. Vector fields and fixed points of an attractor network.

High state of the attractor network happens at the upper fixed point (rightmost full yellow circle). Low state happens at the lower fixed point (left most full yellow circle). Middle fixed point (middle empty yellow circle) represents the threshold between high and low state. With other words, sufficient intensity appears over threshold, maximum intensity occurs at the upper fixed point and lowest intensity occurs at the lower fixed point. **Figure 10** shows the conditions when an attractor network has intensities over and below a threshold. If there are enough forces, a particle in the vector fields moves to the high fixed point. Otherwise, a particle moves to the lower fixed point. The initial position of the particle can vary.

Figure 11 shows the time course for initiation of a motor command. Firstly, the Purkinje cell discharge starts. It takes sometime for the attractor network to reach the high state. The attractor network states at the high state approximately between 100 and 1000 ms. Then, the Purkinje cell charge (firing) starts and the attractor network

state returns back to the low state. The attractor network stays at the low state. This sequence produces the signaling shown in **Figure 7**.

6. CONCLUSIONS

In this work, a microscopic module of an M1-DPM has been implemented using the non-linear equations given above and a sigmoid transfer function within the scope of the agent of the mind idea. The simulations produce the same signaling that occurs in an attractor network between a nuclear neuron and a motor cortical neuron for different Purkinje cell values. The produced signaling imitates a tiny motion upwards in a complete motion such as reaching a glass cup. The future work will simulate motion in other directions (down, right and left). Netlogo 3.1 is a suitable environment for producing the micro and macro behaviors of hundreds of DPMs for a complete motion task.

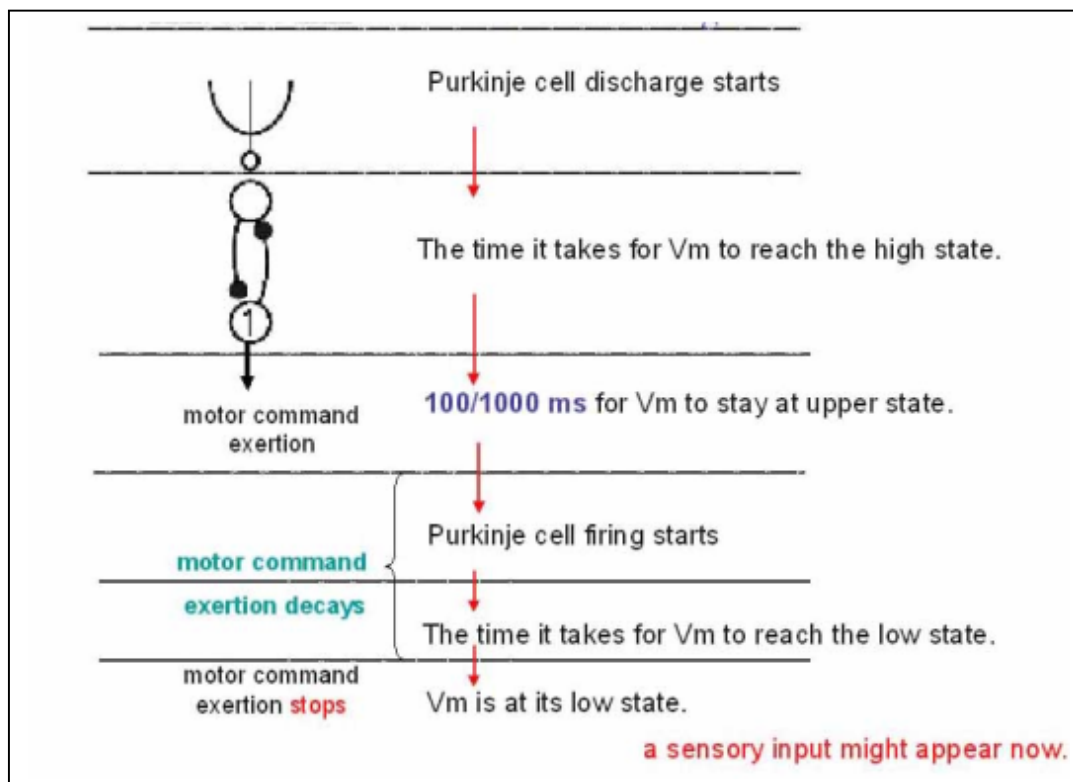

Figure 11. Vector fields and fixed points of an attractor network.

References

Ekerot C.F. and O. Oscarsson, 1981, "Prolonged Depolarization Elicited in Purkinje Cell Dendrites by Climbing Fibre Impulses in the Cat", *Physiology*, 318, (September): 207-221.

Houk J.C., 2005, "Agents of the Mind", *Biological Cybernetics*, 92, no.6, 427-437.

Houk J.C., D. Fraser, A. Fischbach., S.A. Roy, L.S. Simo, C. Bastianen, D. Fansler-Wald, L.E. Miller, P.J. Reber, M.M. Botvinick. 2005. "Action Selection in Subcortical Loops Through Basal Ganglia", *Proceeding of 1st MNAS Workshop*.

Houk, J.C. and Miller, L.E. (2001) *Cerebellum: Movement Regulation and Cognitive Functions*. Encyclopedia of Life Sciences, Macmillan.

Minsky, M.L., 1988. *The Society of Mind*. Simon & Schuster.

Holdefer R.N., L.E. Miller, L.L. Chen, J.C. Houk, 2000, "Functional Connectivity between Cerebellum and Primary Motor Cortex in the Awake Monkey", *Journal of Neurophysiology*, 84, 585-590.

Sarrafizadeh R, J. Keifer, J.C. Houk, 1996, "Somatosensory And Movement-Related Properties Of Red Nucleus: A Single Unit Study In The Turtle", *Experimental Brain Research*, 108, no.1, 1-17.

Yuen G.L., P.E. Hockberger, J.C. Houk, 1995, "Bistability in cerebellar Purkinje cell dendrites modelled with high-threshold calcium and delayed-rectifier potassium channels", *Biological Cybernetics*, 73, no.4, (September): 375-388.

Abbreviations/ Acronyms

DPM: Computational Distributed Processing Module

M1: Anatomical area in the cerebral cortex which produces voluntary commands via its loops through basal ganglia and cerebellum.

M1-DPM: Computational Distributed Processing Module for M1 area

PC: Purkinje cell

CN: Cerebellar Nucleus

OP: Output Population

MF: Mossy Fiber

CF: Climbing Fiber

p: the firing rate of Purkinje cell

bb: bias input to the motor cortical neuron

m: motor cortical neuron

n: nuclear neuron

Rm: the firing rate of neuron m

Vm: the membrane potential of neuron m

Rn: the firing rate of neuron n

Vn: the membrane potential of neuron n

T: constant time factor

f: activation function

w: the synaptic weight between m and n

Acknowledgements

We would like to thank Dr. Bill Rand from Northwestern University for his help with using the Netlogo 3.1 agent-based programming environment. We also would like to thank Ender Yildirim for his help in editing the pictures in the original draft into their final versions.

Biography

Sule Yildirim is an associate professor and head of computer science department in Hedmark University College, Norway. She is teaching artificial intelligence and computer science courses at the undergraduate and graduate level and supervising several master students in the field of artificial intelligence. She has been in a program committee for and co-chaired several computer science/artificial intelligence relevant conferences. She received her PhD from Ege University, Turkey in 2002. She worked as a postdoctoral fellow and assistant professor in Intelligent Systems Department in Norwegian University of Science and Technology after graduation. She had one year visiting scholar position in USA before these positions. She has also worked in industry as a computer engineer before her research positions. She has/had research collaborations/project funding applications with researches from institutions in UK, USA and Sweden. She is author/co-author of some scientific publications. She is both interested in computational modeling of the complexities of human mind and building intelligent systems that are support to humans. Her research work spans a wide variety of topics in Artificial Intelligence such as planning, re-planning, learning and adaptive agents in unstructured and uncertain environments, computational models of high level thinking (learning of concepts and conceptual associations), modeling of natural language parsing, learning of threat detection scenarios in real-time video data, computer games and computational neuroscience.

Gregory Dam is currently a Neuroscience graduate student at Northwestern University. His research interests are in the areas of computational neuroscience, machine learning and psychophysics.

James (Jim) Houk originally studied electrical engineering and received an MS degree from MIT in 1963, working with Prof. Larry Stark on engineering models of the movement control system. He transferred to Harvard to study neurophysiology, under the mentorship of Prof. Elwood Henneman, and conducted his Ph.D. dissertation on Golgi tendon organs. He then did a postdoctoral fellowship in France, studying muscle spindle receptors with Prof. Yves LaPort. Back in Boston as an Assistant Professor at Harvard Medical School, he studied the mechanisms of neuromuscular control in the spinal cord. As Associate Professor at the Johns Hopkins Medical School, he began to

work on brain function. He learned the techniques for recording from single nerve cells in behaving monkeys from Vernon Mountcastle. After 23 years as chair of the department of physiology at Northwestern University Medical School, he decided to step down in 2001 and is now concentrating on multimodal approaches to studying the signal processing operations of the brain. He is attempting to understand how the nonlinear dynamics of microscopic modules in the brain give rise to the unique computational properties of distributed processing modules (DPMs). DPMs are the macroscopic modules described in Houk (2005) that connect individual areas of the cerebral cortex with the basal ganglia and with the cerebellum. He is beginning to explore the emergent properties of networks of DPMs and how they give rise to language and thinking. Houk is also interested in brain processes that underlie Parkinson's disease and in the etiology of schizophrenia.

: