

Tissue Engineering and Regenerative Medicine, Vol. 8, No. 1, pp 62-68 (2011)

| Original Article |

Effects of Anodized Implants Coated With *Escherichia coli*-Derived Recombinant Human Bone Morphogenetic Protein-2 on Osseointegration in Rabbits

Jung-Bo Huh^{1†}, Jae-Jun Ryu^{1†}, Jong-Eun Kim¹, Do-Wan Kim², Sun-Jong Kim³,
Young-Bum Park⁴, Young-Su Kim¹, Su-Young Lee⁵, Jeong-Yeol Lee¹, and Sang-Wan Shin^{1*}

¹Institute for Clinical Dental Research, Korea University, Seoul 152-703, Korea, ²Hyo dental clinic, Gwangju 502-201, Korea

³Department of Oral and maxillofacial Surgery, Ewha Womans University hospital, Seoul 158-701, Korea

⁴Department of Prosthodontics, College of Dentistry, Yonsei University, Seoul 102-752, Korea

⁵Department of Prosthodontics and Dental Research Institute, College of Dentistry Seoul National University, Seoul 110-749, Korea

(Received: August 26th, 2010; Accepted: January 7th, 2011)

Abstract : The aim of the present study was to evaluate the effects of anodized implants coated with *Escherichia coli*-derived recombinant human bone morphogenetic protein-2 (ErhBMP-2) on osseointegration using stability tests and histometric analysis. Nine adult New Zealand white rabbits (4.5-5 kg) were used in the study. Thirty-six implants (L, 5.0 mm; D, 4.0 mm) were divided into 2 groups: anodized implants (control group) and ErhBMP-2 (1.5 mg/ml concentration, 18 µg; Cowellmedi Co, Busan, Korea) coated anodized implant (experimental group). In each rabbit, 4 implants were placed in the tibia on both sides. The control and experimental implants were randomly placed in either left or right tibia. The rabbits were sacrificed at the end of the healing period (2, 4 and 12 weeks after operation). The stability of implants was evaluated by resonance frequency analysis. To obtain histometric results, bone to implant contact (BIC) and intra-thread bone density (ITBD) were measured with a light microscope. The ISQ value was significantly greater in the experimental group than in the control group at 12 weeks ($P<0.05$). ITBD increased over time in the experimental group ($P<0.05$). Post hoc comparison test analysis showed that a statistically significant change could be found between 2 and 4 weeks in the interaction between the ITBD change by time lapse and an ErhBMP-2 application condition ($P=0.033$). In this study, a greater degree of osseointegration was observed in the experimental group. ErhBMP-2 coated anodized implants could be used particularly in cases where bone quality is poor or bone volume is insufficient.

Key words: ErhBMP-2, anodized implant, ISQ, histometric analysis, osseointegration

1. Introduction

BMP, a protein from a subgroup of the transforming growth factor family, accelerates ossification by controlling the essential factors of the bone induction cascade, resulting in the proliferation of osteoblasts from mesenchymal stem cells and the biosynthesis of bone matrix.¹⁻⁶ Because BMP-2 possesses high osteoinductive potential,⁷ it has been considered to be an interesting candidate growth factor to coat titanium implants. While BMP-2 has been more commonly used, BMP-4 is currently considered as a candidate growth factor that might improve the remodeling process at the bone-implant interface.⁸

BMP-2 has proved to be beneficial, thus it can be used for various medical treatments.⁹ It has been reported that recombinant human BMP-2 (rhBMP-2), which is extracted by the gene recombination technique, can execute an osteoinductive effect when coated on the surface of implants.¹⁰⁻¹² In particular, Hall et al¹⁰ concluded that an osteoinductive effect, including bone contact with the implant surface, is in the advantage of titanium porous oxide surface (anodized surface) in yielding the most bone at a low discriminating rhBMP-2 dose.

Recombinant human BMPs are currently produced by BMP gene-transfected mammalian cell (CHO) cultures^{13,14} and rhBMP-2 and BMP-7 (rhBMP-7/ osteogenic protein-1 [OP-1]) are commercially available for the treatment of bony defects.^{15,16} One of the problems associated with clinical application of CHO-cell-derived rhBMP-2 (CrhBMP-2) is its high cost due to a high dose requirement. One possible way of solving this problem is to

[†]These authors contributed equally to this work

*Tel: +82-2-2626-1922; Fax: +82-2-2626-1923

e-mail: swshin@korea.ac.kr (Sang-Wan Shin)

produce monomer rhBMPs in BMP-gene transfected *Escherichia coli* (*E. coli*) with a high efficiency of production and low cost. Besso et al¹⁷ examined the bone-inducing ability of an *E. coli*-derived rhBMP-2 (ErhBMP-2) variant with an N-terminal sequence and compared it with CrhBMP-2. Quantitative analysis indicated that the activity of ErhBMP-2 is similar to that of CrhBMP-2. However, it is unclear whether the characteristics of ErhBMP-2 are appropriate for clinical application. In particular, the outcome and effect of ErhBMP-2 coating in osseointegration have not yet been determined. Therefore, the present study was conducted to evaluate the effect of ErhBMP-2 on the osseointegration of anodized implants using stability tests and histometric analysis.

2. Materials and Methods

2.1 Fabrication of Implant

Thirty-six implants (5.0 mm in length, 4.0 mm in diameter; Cowellmedi Co, Busan, Korea) were fabricated (Table 1). All thread-type implants were made of pure titanium, and they were designed to have microthreads on the upper part, and broader threads on the lower part (Fig 1). The implant surface was treated by the anodizing method (Cowellmedi Co), and half of the implant (18 implants) was processed by coating with ErhBMP-2 (Cowellmedi Co). The bioactivity of ErhBMP-2 (Cowellmedi Co., Pusan Korea) used in this study was validated in the recent study regarding the possibility of vertical bone growth using ErhBMP-2 coated implant.¹⁸ To coat with ErhBMP-2, they were immersed 3 times in protein solution (1.5 mg/ml concentration) up to the microthreads of the implants and were freeze dried under sterile conditions (Freeze drying at -40°C, followed by vacuum drying at maximum 20°C). The total dose of ErhBMP-2 coated onto implant was 18 µg in each implant.

2.2 Experimental Animals

This study was carried out with the approval from the Ethics Committee on Animal Experimentation of Korea University (UIACUC-20091203-1). Nine adult New Zealand white rabbits (males, 5; females, 4), weighing 4.5-5 kg, were used for

Table 1. Classification of the experimental implants

	Time(Weeks)			Total
	2 wk	4 wk	12 wk	
Control Group	6	6	6	18
Experimental Group	6	6	6	18
Total	12	12	12	36

Control Group: Anodized implant

Experimental Group: Anodized implant coated with ErhBMP-2

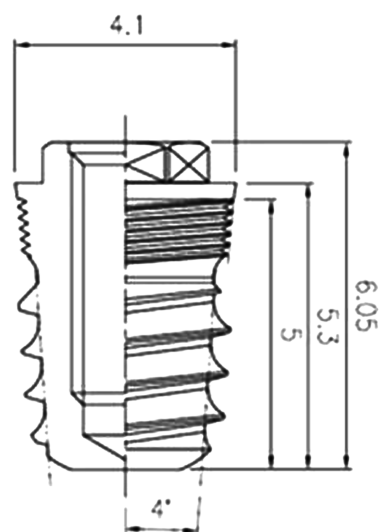

Figure 1. Diagram of implant. The implant was designed to have microthreads on the upper part and broader threads on the lower part (5.0 mm in length, 4.0 mm in diameter).

this study and given 2 weeks to acclimatize. The rabbits were given conventional laboratory diet during the observation period. During surgery, Zoletil50® (Vibac, Carros, France) at an intramuscular dose of 0.16 ml/kg was used for general anesthesia and approximately 1 ml of lidocaine (Yu-Han Co, Gunpo, Korea) with epinephrine 1:100,000 was infiltrated into the mucosa of the surgical site.

2.3 Surgical Procedure

2.3.1 Implant Surgery

All animal experiments were performed in an absolute sterile animal experimentation room. The rabbits were laid down on their back with the limbs immobilized, and they were disinfected before a semilunar incision was made in the part of the articulating area of the limb to separate skin, fascia and periosteum.

For the placement of implants at the same location on both sides, the exposed bone was marked at the implant placement sites using a ruler. A guide drill in an implant surgical set (Cowellmedi Co) was used to drill cortical bone, and then a 2-mm first drill, a 3-mm pilot drill and a 3.2-mm final drill were used before countersinking. Four implants were placed in the tibia on both sides. However, since ErhBMP-2 released in ErhBMP-2-coated implants can modify the surrounding environment, the control and experimental implants were placed in either the left or right side. Implant stability quotient (ISQ) values were measured for each implant to evaluate stability at the time of implant placement. To suture periosteum and skin separately, 4-0 nylon (Mersilk, Ethicon Co, Livingston, U.K.) was used.

2.3.2 Postoperative Care and Sacrifice

The rabbits were administered gentamicin intramuscularly (4 ml/kg; Kukje Pharmacy, Sungnam, Korea) immediately and 24 hours after surgery. Sutures were removed 1 week after the placement of implants. The rabbits were given a soft diet for 2 weeks after surgery, followed by a conventional regular diet. The experimental rabbits were divided into 3 groups based on the time of sacrifice (2, 4 and 12 weeks after operation).

2.4 Measurement of Various Parameters

2.4.1 Assessment of Implant Stability

Implants placed in the tibia were measured for ISQ by Osstell Mentor (Integration Diagnostic Ltd, Göteborg, Sweden) during surgery, and 2, 4 and 12 weeks after surgery. ISQ values were recorded 5 times for each implant, and 3 values excluding the minimum and maximum values were calculated for the mean and standard deviation for the evaluation of changes in implant stability.

2.4.2 Histometric Analysis

At the end of each time point, the animals were sacrificed, and specimens including the implants were collected from the tibia after the measurement of implant stability using Osstell Mentor. The specimens were fixed in neutral buffered formalin (Sigma Aldrich, St Louis, MO, USA) for 2 weeks and dehydrated in ascending concentrations of ethanol 70%, 80%, 90% and 100%. The dehydrated specimens were embedded in Technovit 7200 resin (Heraeus KULZER, South Bend, IN, USA). The blocks of the polymerized specimens were sectioned longitudinally from the center of each implant by an EXAKT diamond cutter (KULZER EXAKT 300, EXAKT, Norderstedt, Germany). The 30- μm final slides were prepared from the initial 400- μm slides by grinding the sections with an EXAKT grinding machine (KULZER EXAKT 400CS, EXAKT). The specimens were stained with Goldner Trichrome. The images were captured using a computer connected light microscope (Olympus BX, Tokyo, Japan) attached to a CCD camera (Polaroid DMC2 digital Microscope Camera (Polaroid Corporation, Cambridge, MA, USA)). All measurements were made using SPOT Software V4.0 (Diagnostic Instrument, Inc., Sterling Heights, MI, USA). The percentage of BIC was measured, and the ratio of the area of bone formation on intra-threads of the implant to overall threads was calculated for the measurement of ITBD (Fig 2). The bone superior to the most apical thread was not included due to difficulty in objectification. Overall specimen images were captured at a magnification of X2.5. A magnification of X40 was used for histometric analysis, and a 100X magnification lens for a precise assessment of BIC. The criteria for histometric analysis

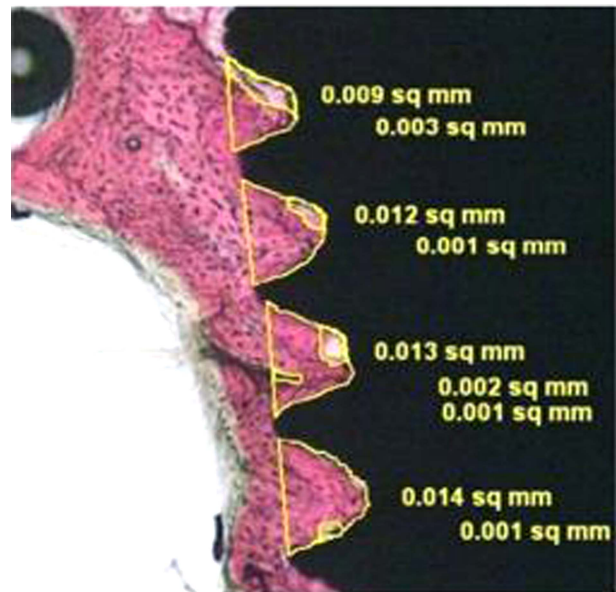

Figure 2. Measurement of intra-thread bone density. The ratio of the area of bone formation on intra-threads of implant to overall threads was calculated for the measurement of bone density (X 40).

included images that were captured at a magnification of 40X.

2.5 Statistical Analysis

The mean and SD of the ISQ values, BIC and ITBD in the histologic specimens were calculated for each group. The statistical analysis for ISQ values was performed using the Shapiro-Wilk method for normality test. Comparisons between the experimental and control groups were made in the same week using the Mann-Whitney *U* test. Analyses at periodic time points were performed for the same group using the Friedman test. Statistical analyses for BIC and ITBD were performed using ANOVA (SPSS Inc, Chicago, IL, USA). *Post hoc* comparison test analysis was used for finding the interaction between the bone density change by a time lapse and an ErhBMP-2 application condition. Statistical significance was established at the 95% confidence level.

3. Results

3.1 ISQ Value

The overall ISQ value was higher in the control group than in the experimental group immediately after surgery, but the difference was not statistically significant. In the control group, the ISQ value was relatively high at 2 weeks, but gradually decreased at 4 and 12 weeks. However, in the experimental group, the ISQ value was relatively low at 2 weeks but gradually

Table 2. Implant stability quotient (ISQ) values (mean \pm SD).

	Time (Weeks)			
	0	2	4	12
Control group	55.67 \pm 13.94	60.50 \pm 6.83	55.17 \pm 13.36	53.00 \pm 11.37
Experimental group	56.33 \pm 16.77	44.17 \pm 13.36	61.17 \pm 7.96	72.17 \pm 4.12
P-value	0.87	0.03	0.42	0.002

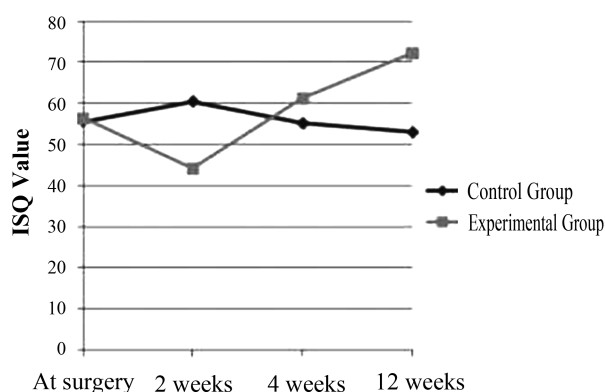

Figure 3. Implant stability quotient (ISQ) (mean \pm SD) A higher ISQ value was recorded in the control group immediately after surgery although the difference was not statistically significant. In the control group, the ISQ value was slightly high at 2 weeks, while the values decreased gradually at 4 and 12 weeks. In the experimental group, the ISQ value was relatively low at 2 weeks than immediately after surgery but gradually increased at 4 and 12 weeks. The difference between the 2 groups was statistically significant at 2 and 12 weeks ($P < 0.05$).

increased at 4 and 12 weeks (Table 2). The difference between the 2 groups was statistically significant at 2 and 12 weeks ($P < 0.05$) (Fig 3). The Friedman test, which is used to assess statistical significance at different time points in the same group, revealed that the experimental group showed an increase in the ISQ value with time ($P < 0.05$).

3.2 Histometric Analysis

The experimental group showed increased BIC at 2, 4 and 12 weeks after surgery. In the control group, BIC increased up to 4 weeks and decreased at 12 weeks. Although there was no statistical significance between the 2 groups, the experimental group showed a larger BIC at 12 weeks (Table 3). Considering ITBD, the experimental group demonstrated a continuous increase, while the control group showed a slight decrease (Figs 4 and Table 3). We used repeated-measures ANOVA for statistical analysis. The Mauchly test indicated that the assumption of sphericity had not been violated ($\chi^2 = 2.820$, $P > 0.05$). The results of the multivariate tests in the process of repeated-measures ANOVA showed that the ITBD score by time lapse was not significantly affected by the ErhBMP-2 application ($P > 0.05$). The interaction between ITBD score by time lapse and ErhBMP-2 application was statistically significant ($P = 0.044$). *Post hoc* comparison analysis showed that a statistically significant change could be found from 2 to 4 weeks between ITBD score by a time lapse and ErhBMP-2 application condition ($P = 0.033$).

4. Discussion

BMPs were identified as osteoinductive proteins more than 40 years ago.¹⁹ Since the BMP gene was cloned, studies and clinical applications of BMP have been widely conducted. A problem associated with the clinical use of BMPs is their high cost of production, since they are originally derived from

Table 3. Histometric parameters for osseointegration (means \pm SD of BIC and bone density).

	Bone to implant contact (%)		Intra-thread bone density (%)	
	Control	Experimental	Control	Experimental
Week 2	21.62 \pm 10.16	23.51 \pm 16.27	67.52 \pm 8.97	44.77 \pm 15.09
Week 4	30.61 \pm 31.33	29.13 \pm 14.51	59.26 \pm 25.03	77.20 \pm 9.93
Week 12	23.82 \pm 9.79	34.63 \pm 15.17	58.66 \pm 29.63	70.20 \pm 7.32

The mean percentage of Bone to implant contact (BIC) and intra-thread bone density (ITBD) in individual groups. The overall BIC showed no significant differences at 2 and 4 weeks between the 2 groups, but a higher BIC was observed in the experimental group at 12 weeks. ITBD was significantly less in the experimental (ErhBMP-2) group at 2 weeks, but it showed a relatively great bone volume after 4 and 12 weeks, whereas the control group showed a decreased bone volume at 4 and 12 weeks. There was a statistical significance in the interaction between study conditions (ErhBMP-2 and control groups) and periods (2, 4 and 12 weeks)



Figure 4. Light microphotographs ($\times 12.5$). Control group (A, 2 weeks; B, 4 weeks; C, 12 weeks), Experimental group (D, 2 weeks; E, 4 weeks; F, 12 weeks). Implants were inserted in the tibia of the rabbit that had a poor bone quality. The experimental group demonstrated an increase in ITBD. However, there was no statistically significant difference in BIC at a magnification of X40.

mammalian CHO cells.²⁰ To solve this problem, Sebald *et al.*^{21,22} devised a novel method to produce rhBMP-2 derived from *E. coli* and convert BMP monomers to biologically active dimers (ErhBMP-2). ErhBMP-2 has an osteoinductive activity which is similar to CHO-derived rhBMP-2 both *in vivo* and *in vitro*.²³ However, these reports included only results for ErhBMP-2-induced ectopic bone formation. The aim of our study was to determine whether anodized implant coated with ErhBMP-2 could achieve better osseointegration than non-coated implant in a rabbit tibia model. In this study, the total dose of ErhBMP-2 coated and the concentration of ErhBMP-2 were 18 μg and 1.5 mg/ml in each implant respectively. These values were referenced by previous studies conducted on the effectiveness of implant coated with CHO cell derived rhBMP-2 on osseointegration and vertical bone gain.¹¹⁻¹² Bone growth was observed around the cervical area of ErhBMP-2 coated implants when animals were sacrificed. It may be possibly due to the peel-off and accumulation of ErhBMP-2 at the bone crest while driving the implant into the bone drill hole for implant installation. As the exact peel-off dose could not be measured,

further studies are needed to find out peel-off amount and accumulating area.

There were some limitations in this study. First, we used a rabbit tibia model. For clinical application, studies must be performed in much larger animals such as sheep or non-human primates since the efficacy of cytokines and BMPs vary in different species. In addition, bone quality in a rabbit tibia model may differ depending on the site of implant placement. In this study, differences in the initial stability were noted in the same test subject depending on the site of implant placement. Second, the sample size in each group was not sufficient to yield substantial results, and the study is likely underpowered.

Despite the limitations in this study with rabbits, the experimental group showed a greater implant stability that was statistically significant especially at 12 weeks. The findings of this study are in accordance with other studies using rhBMP-2-coated implants.³⁻⁵ The experimental group showed reduced implant stability at 2 weeks, but the stability increased at 4 and 12 weeks. In the experimental group, the reduced implant stability at 2 weeks may be attributed to rhBMP-2 facilitating

the proliferation of osteoclasts during the early stage of bone healing, while at 4 and 12 weeks, the increased implant stability may be due to the overall promotion of bone healing. Previous studies have demonstrated that besides the promotion of bone formation, BMPs stimulate recruitment, proliferation and differentiation of osteoclasts.^{7,24} Hence, they may promote the resorption of newly formed bone almost as soon as it has been laid down onto a titanium implant surface.²⁴ As compared to the existing non-ErhBMP-2-coated implants, the ErhBMP-2 coated implants may not be ideal for immediate loading, but they may be more suitable for delayed loading (12 weeks).

The implants were stabilized at the initial time of implant placement by compressing cortical bone. It may be speculated that the decrease in implant stability at 2, 4 and 12 weeks was caused by the remodeling of cortical bone by compression. The tibias of the rabbits are composed of thin cortical bone and low cancellous bone that are not optimal for anodized implant osseointegration. Based on this result, osseointegration of the ErhBMP-2 coated implants could be achieved even at sites of poor bone quality.

Histometric evaluation revealed a significant difference in ITBD in the experimental group. ISQ values at 2 and 12 weeks were in agreement with ITBD values, while ISQ value at 4 weeks failed to show a significant correlation with bone formation. The bone was not sufficiently mature at 4 weeks to increase the ISQ value, despite the formation of new bone promoted by ErhBMP-2. The overall BIC showed no significant differences at 2 and 4 weeks between the 2 groups, but a higher BIC was observed in the experimental group at 12 weeks. A statistically significant difference between the 2 groups was not observed ($P>0.05$).

ISQ showed that the ErhBMP-2-coated implants were more effective for osseointegration. A higher ISQ value was recorded in the control group immediately after surgery, even though it was not statistically significant. In the control group, ISQ value was slightly higher at 2 weeks, but it decreased gradually at 4 and 12 weeks. The experimental group showed a smaller ISQ value at 2 weeks than immediately after surgery, while the values gradually increased at 4 and 12 weeks. The difference between the 2 groups was statistically significant at 2 and 12 weeks ($P<0.05$). Considering the difficulty in obtaining good initial stability in rabbits due to poor bone quality, a higher ISQ value at 12 weeks in the experimental group suggests that ErhBMP-2 may be a positive factor for facilitating favorable outcomes for osseointegration.

Numerous articles have recently been published on the significance of rhBMP-2 concentration. In addition to the published papers, our study warrants further investigation using ErhBMP-2-coated anodized implants to evaluate outcomes

when various concentrations of ErhBMP-2 are applied. Further studies are also needed to find out the ideal healing period for implant stability.

6. Conclusion

Implant stability was similar in both groups at 2 and 4 weeks, whereas the experimental group showed a greater implant stability at 12 weeks than the control group. Histometric analysis revealed that ITBD was significantly higher with time in the experimental group than in the control group. Although there were some limitations in this study, a greater degree of osseointegration was observed in the experimental group. ErhBMP-2-coated anodized implants may be useful particularly in cases where bone quality is poor or bone volume is insufficient.

Acknowledgments: This study was supported by Korea University grant and a grant from the Korea Healthcare Technology R&D Project. Ministry for Health, Welfare & Family Affairs, Republic of Korea (A090084).

References

1. AH Reddi, Bone and cartilage differentiation, *Curr Opin Genet Dev*, **4**, 737 (1994).
2. AH Reddi, Role of morphogenetic proteins in skeletal tissue engineering and regeneration, *Nat Biotechnol*, **16**, 247 (1998).
3. MP Bostrom, P Asnis, Transforming growth factor beta in fracture repair, *Clin Ortho*, **355**, 124 (1998).
4. GL Barnes, PJ Kostenuik, LC Gerstenfeld, *et al.*, Growth factor regulation of fracture repair, *Bone Miner Res*, **14**, 1805 (1999).
5. PC Bessa, M Casal, RL Reis, Bone morphogenetic proteins in tissue engineering: the road from the laboratory to the clinic, part I (basic concepts), *J Tissue Eng Regen Med*, **2**, 1 (2008).
6. PC Bessa, M Casal, RL Reis, Bone morphogenetic proteins in tissue engineering: the road from laboratory to clinic, part II (BMP delivery), *J Tissue Eng Regen Med*, **2**, 81 (2008).
7. MT Laub, E Seul, E Schmachtenberg, *et al.*, Molecular modelling of bonemorphogenetic protein-2 (BMP-2) by 3D-rapid prototyping, *Materialwissenschaft und Werkstofftechnik*, **32**, 926 (2001).
8. B Stadlinger, E Pilling, M Huhle, *et al.*, Evaluation of osseointegration of dental implants coated with collagen, chondroitin sulphate and BMP-4: an animal study, *The International Journal of Oral & Maxillofacial Implants*, **37**, 54 (2008).
9. D Chen, M Zhao, GR Mundy, Bone morphogenetic proteins, *Growth Factors*, **22**(4), 233 (2004).
10. J Hall, RG Sorensen, JM Wozney, *et al.*, Bone formation at rhBMP-2-coated titanium implants in the rat ectopic model, *J Clin Periodontol*, **34**(5), 444 (2007).
11. UME Wikesjo, AV Xiropaidis, M Qaghsh, *et al.*, Bone

- formation at recombinant human bone morphogenetic protein-2-coated titanium implants in the posterior mandible (Type II Bone) in dogs, *J Clin Periodontol*, **35**, 985 (2008).
12. KN Leknes, J Yang, M Qahash, *et al.*, Alveolar ridge augmentation using implants coated with recombinant human bone morphogenetic protein-2: radiographic observations, *Clin Oral Implants Res*, **19**(10), 1027 (2008).
 13. EA Wang, V Rosen, JS D'Alessandro, *et al.*, Recombinant human bone morphogenetic protein induces bone formation, *Proc Natl Acad Sci USA*, **87**, 2220 (1990).
 14. DI Israel, J Nove, KM Kerns, *et al.*, Heterodimeric bone morphogenetic proteins show enhanced activity in vitro and in vivo, *Growth Factors* **13**, 291 (1996).
 15. GE Friedlaender, CR Pery, JD Cole, *et al.*, Osteogenic protein-1 (bone morphogenetic protein-7) in the treatment of tibial nonunions, *J Bone Joint Surg Am*, **83A**, 151 (2001).
 16. JK Burkus, SE Heim, MF Gornet, *et al.*, Is INFUSE bone graft superior to autograft bone? An integrated analysis of clinical trials using the LT-CAGE lumbar tapered fusion device, *J Spinal Disord Tech*, **16**, 113 (2003).
 17. K Bessho, Y Konishi, S Kaihara, *et al.*, Bone induction by Escherichia coli -derived recombinant human bone morphogenetic protein-2 compared with Chinese hamster ovary cell-derived recombinant human bone morphogenetic protein-2, *Br J Oral Maxillofac Surg*, **38**, 645 (2000).
 18. JB Huh, CK Park, SE Kim, *et al.*, Alveolar ridge augmentation using anodized implants coated with Escherichia coli-derived recombinant human bone morphogenetic protein 2. *Oral Surg Oral Med Oral Pathol Oral Radiol Endod*, Dec, 29 (2010) [Epub ahead of print].
 19. MR Urist, Bone: formation by autoinduction, *Science*, **150**, 893(1965).
 20. JM Wozney, V Rosen, AJ Celeste, *et al.*, Novel regulators of bone formation: molecular clones and activities, *Science*, **242**, 1528 (1988).
 21. NR Kubler, JF Reuther, G Faller, *et al.*, Inductive properties of recombinant human BMP-2 produced in a bacterial expression system, *Int J Oral Maxillofac Surg*, **27**, 305 (1998).
 22. R Ruppert, E Hoffmann, W Sebald, Human bone morphogenetic protein 2 contains a heparin-binding site which modifies its biological activity, *Eur J Biochem*, **237**, 295 (1996).
 23. K Yano, M Hoshino, Y Ohta, *et al.*, Osteoinductive capacity and heat stability of recombinant human bone morphogenetic protein-2 produced by Escherichia coli and dimerized by biochemical processing, *J Bone Miner Metab*, **27**, 355 (2009).
 24. Y Liu, RO Huse, K De Groo, *et al.*, Delivery mode and efficacy of BMP-2 associated with implants, *Journal of Dental Research*, **86**, 84 (2007).