

**Manuscript version: Author's Accepted Manuscript**

The version presented in WRAP is the author's accepted manuscript and may differ from the published version or Version of Record.

**Persistent WRAP URL:**

<http://wrap.warwick.ac.uk/124205>

**How to cite:**

Please refer to published version for the most recent bibliographic citation information. If a published version is known of, the repository item page linked to above, will contain details on accessing it.

**Copyright and reuse:**

The Warwick Research Archive Portal (WRAP) makes this work by researchers of the University of Warwick available open access under the following conditions.

Copyright © and all moral rights to the version of the paper presented here belong to the individual author(s) and/or other copyright owners. To the extent reasonable and practicable the material made available in WRAP has been checked for eligibility before being made available.

Copies of full items can be used for personal research or study, educational, or not-for-profit purposes without prior permission or charge. Provided that the authors, title and full bibliographic details are credited, a hyperlink and/or URL is given for the original metadata page and the content is not changed in any way.

**Publisher's statement:**

Please refer to the repository item page, publisher's statement section, for further information.

For more information, please contact the WRAP Team at: [wrap@warwick.ac.uk](mailto:wrap@warwick.ac.uk).

# Design and Analysis of an Acknowledgment-Aware Asynchronous MPR MAC Protocol for Distributed WLANs

Arpan Mukhopadhyay, Neelesh B. Mehta, *Senior Member, IEEE*, Vikram Srinivasan, *Member, IEEE*

**Abstract**—Multi-packet reception (MPR) promises significant throughput gains in wireless local area networks (WLANs) by allowing nodes to transmit even in the presence of ongoing transmissions in the medium. However, the medium access control (MAC) layer must now be redesigned to facilitate – rather than discourage – these overlapping transmissions. We investigate asynchronous MPR MAC protocols, which successfully accomplish this by controlling the node behavior based on the number of ongoing transmissions in the channel. The protocols use the backoff timer mechanism of the distributed coordination function (DCF), which makes them distributed and practically appealing. We first highlight a unique problem of acknowledgment (ACK) delays, which arises in asynchronous MPR, and investigate a solution that modifies the medium access rules to reduce these delays and increase system throughput in the single receiver scenario. We develop a general renewal-theoretic fixed-point analysis of the solution and derive expressions for its saturation throughput, packet dropping probability, and average head-of-line packet delay. We also model and analyze the practical scenario in which nodes may incorrectly estimate the number of ongoing transmissions.

**Index Terms**—Cross-layer design, Medium access control, Multi-packet reception, Wireless local area network, IEEE 802.11, Fixed-point analysis, Timer backoff

## I. INTRODUCTION

Conventional wireless local area networks (WLANs), which use the IEEE 802.11 distributed coordination function (DCF) [1] and its enhancements as medium access control (MAC) protocols, are facing increasing demands for higher data rates and higher system throughput. Conventionally, a layered approach is adopted in designing the physical (PHY) and MAC layers. For example, the DCF MAC uses carrier sense multiple access (CSMA) with collision avoidance (CA) to discourage time-overlapping transmissions by multiple users in the uplink channel from the nodes to the AP. This is accomplished by making the nodes freeze their backoff timers anytime they sense an ongoing transmission in the channel.

With the advent of advanced signal processing techniques based on code division multiple access (CDMA), successive interference cancellation (SIC), or multiple antennas, today's

wireless receivers are capable of decoding multiple simultaneous transmissions. This has been referred to as the multi-packet reception (MPR) capability [2]–[9]. Instead of discouraging overlapping transmissions, the MAC layer must now facilitate their occurrence in order to benefit from MPR. At the same time, the MAC should retain the distributed manner in which nodes access the medium, as this is a key reason behind the success of the IEEE 802.11 DCF MAC.

### A. Related Literature

We now summarize some key papers on MPR and ascertain their efficacy, distributed nature, and suitability for an IEEE 802.11-type DCF MAC. MPR was first considered in [8], [10] for slotted ALOHA, but CSMA was not modeled. An adaptive MAC protocol for MPR that maximizes the expected number of successfully transmitted packets per slot and also takes into account quality of service requirements was proposed in [5]. A simpler variant based on collision resolution was proposed in [11]. A similar objective was achieved in [4] for space division multiple access systems (SDMA) that use multiple antenna APs. However, these protocols require a central controller that selects an optimal set of users that access the channel in each slot.

MPR with CSMA was analyzed in [12], [13]. In [12], each node uses channel sensing to determine whether or not the channel can support more ongoing transmissions and then transmits accordingly. However, neither acknowledgements (ACKs) nor the timer-based backoff mechanism of IEEE 802.11 were modeled. In [6], [14], timer-based backoff protocols for IEEE 802.11 WLANs with MPR were considered. However, a *synchronous scenario*, in which transmissions by multiple nodes can only start simultaneously, is assumed. This is achieved by modifying the request-to-send (RTS) and clear-to-send (CTS) handshaking procedure of 802.11. A node is not allowed to transmit once it senses the channel to be busy regardless of the number of ongoing transmissions, which limits the gains possible from using MPR. Further, the overheads of the RTS/CTS procedure have led to its limited adoption in practice, despite its ability to address the hidden node problem. Therefore, it is worthwhile investigating asynchronous MPR MAC protocols that allow overlapping packet transmissions to start at different times. An MPR MAC protocol, that encourages two asynchronous RTS packet transmissions, was proposed in [15] and a two node network was analyzed in it.

A. Mukhopadhyay is with the Dept. of Electrical and Computer Eng. at the Univ. of Waterloo, Canada. N. B. Mehta is with the Dept. of Electrical Communication Eng. at the Indian Institute of Science (IISc), Bangalore, India. V. Srinivasan is with Bell Labs Research, Alcatel-Lucent, Bangalore, India. A. Mukhopadhyay was at IISc during the course of this work.

Emails: arpanmu@gmail.com, nbmehta@ece.iisc.ernet.in

A part of this work has been presented in the IEEE Global Communications Conf. (Globecom), USA, 2012.

A generic, distributed asynchronous MPR model, which exploited the fact that a multiple antenna node can estimate the number of ongoing transmissions, was recently analyzed by Babich and Comisso in [16] using Markov chains. In it, a node continues to decrement its backoff timer and eventually transmits even when it senses the channel to be busy – so long as the number of ongoing transmissions is less than or equal to a threshold; else, it freezes its timer. The protocol was analyzed without any limitation on the number of receivers [17]. However, ACKs were not modeled; it was implicitly assumed that a node knows whether its transmission has succeeded or not immediately after transmitting its packet. Further, nodes were assumed to perfectly estimate the number of ongoing transmissions.

The use of MPR in an asynchronous set up can, in fact, delay the transmission of an ACK by the AP. This is because packet transmissions by different nodes can now start at different time slots and overlap without any idle period in between. Consequently, the AP will have to continue to receive packets even after a particular node completes its transmission. As a result, the transmission of an ACK by the AP, which is a half-duplex node, can get significantly delayed. Since the presence or absence of an ACK makes a node update its backoff parameters, ACK delays can degrade system throughput and increase packet transmission delays.

## B. Contributions

The paper makes several contributions on the following aspects of asynchronous MPR MAC.

*Protocol Design:* The paper first points out that in an asynchronous MPR MAC protocol, ACKs may get delayed. This delay in the reception of ACKs, which is absent in conventional DCF and synchronous MPR protocols, can degrade the system performance. Thus, an asynchronous MPR MAC protocol needs to be designed keeping ACK delays in mind. To this end, we propose and compare two asynchronous MPR MAC protocols both of which incorporate ACKs in the single receiver scenario. The first protocol is our own interpretation of how ACKs can be incorporated in the model analyzed in [16], and serves as a benchmark. In the second protocol, the multiple access rules, which determine when a node should freeze or decrement its backoff timer, are modified to reduce the ACK delays and increase system throughput. In it, nodes freeze their backoff timers once the number of transmissions in the channel reaches the MPR capability of the AP or once any node completes the transmission of its packet. This ensures that a node, which has just finished transmitting its packet, waits for no more than one packet duration to receive an ACK.

*Modeling imperfect estimation:* Another important contribution of the paper is a tractable modeling of the practical scenario where the nodes incorrectly estimate the number of ongoing transmissions in the channel. We show that the first and the second protocols are quite robust to imperfect estimation. Several MPR-specific implementation issues are also discussed.

*Analysis:* Finally, the paper develops a general, renewal-theoretic fixed-point analysis of the second asynchronous MPR

MAC protocol that explicitly takes ACKs into consideration. The analysis can handle the ideal case with perfect estimates and the practical case with imperfect estimates. Analytical expressions for the saturation throughput, packet dropping probability, and average head-of-line packet delay are derived. Saturation throughput is an important performance measure for a MAC protocol and has been extensively analyzed in the literature on conventional 802.11 DCF and MPR. It gives a limit on the system throughput in heavy traffic loads [6], [14], [15], [18], [19]. In some cases, it also provides a sufficient condition for stability of queues at the nodes [20]. The average head-of-line delay is also an important performance measure as it affects higher layers of the protocol stack and is the first step in a queueing delay analysis for a non-saturated traffic scenario [21], [22].

The renewal-theoretic approach developed in this paper is different from the Markovian analysis used in [16], [18]. For example, in our analysis, packet lengths need not follow the memoryless geometric probability distribution, which breaks down under heavy traffic load conditions when a packet suffers many retransmissions [16]. The effect of packet dropping after a finite number of retransmissions is also incorporated. Our analysis also generalizes the renewal-theoretic analysis that was developed in [19] for conventional DCF.

*Performance benchmarking:* We also extensively benchmark the saturation throughput, head-of-line packet delay, and packet dropping probability of the two asynchronous MPR MAC protocols and conventional DCF. This is done for both ideal and imperfect estimation.

The paper is organized as follows. Section II sets up the system model and the asynchronous MPR MAC protocols, which are then analyzed in Section III. Imperfect estimation is modeled and analyzed in Section IV. Simulations results in Section V are followed by our conclusions in Section VI.

## II. SYSTEM MODEL

### A. System Model

Consider the uplink of a WLAN, in which the AP acts as the central node and  $n$  surrounding nodes need to transmit packets directly to the AP. The following MPR data reception model is assumed, along the lines of [6], [14], [16]. The AP can successfully decode all the overlapping transmissions as long as the number of overlapping transmissions is less than or equal to  $L$ . If more than  $L$  overlapping transmissions occur, then the AP fails to decode the transmissions and a collision is said to occur. Here,  $L$  is called the MPR capability.<sup>1</sup> Further, it is assumed that a node can correctly estimate whether the number of ongoing transmissions in the channel is  $0, 1, \dots, L-1$ , or whether it is greater than or equal to  $L$ . Techniques to estimate the number of ongoing transmissions and the effect of imperfect estimates are discussed in Section IV.

Each node follows the timer-based binary exponential back-off scheme of conventional DCF, and a packet is dropped by a node after  $K+1$  failed transmission attempts. Before each transmission attempt, a node selects its backoff period in

<sup>1</sup>This MPR reception capability based model can also be expressed in terms of MPR-matrix model of [2], [5], [8], and [9].

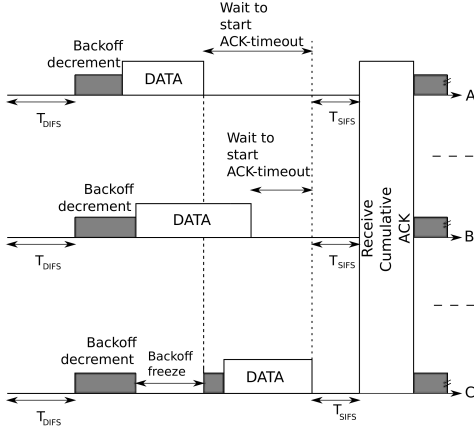

Fig. 1. Protocol 1 for  $L = 2$ : Timing diagram showing a renewal interval in which three overlapping asynchronous transmissions to the AP occur. Node  $A$  transmits first. Nodes  $B$  and  $C$  continue to decrement their timers until node  $B$  transmits. Thereafter,  $C$  freezes its timer. When  $A$ 's transmission ends,  $C$  resumes decrementing its timer. Before the transmission by  $B$  ends, the timer of  $C$  expires, which then starts transmitting. Thus,  $A$  can expect to receive its ACK only after  $C$ 's transmission ends.

integer multiples of a slot duration  $\delta$ . The multiple is uniformly chosen from the set  $\{0, 1, \dots, w - 1\}$ , where  $w$  is called the *contention window*. It depends on the number of failed transmissions of a packet. In the first attempt,  $w$  is set as the minimum contention window  $CW_{\min}$ . After each unsuccessful transmission,  $w$  is doubled, up to a maximum value of  $CW_{\max}$ .

### B. Protocol Design

We now describe two asynchronous MPR MAC protocols without any assumption on the traffic model.

1) *Protocol 1*: This protocol is an asynchronous MPR MAC protocol that is similar to the one in [16], but with ACKs incorporated in it. We note that other ways of incorporating ACKs also exist. A node having a packet first samples a backoff timer duration and starts decrementing it once the channel has remained idle for a distributed inter-frame space (DIFS) of duration  $T_{\text{DIFS}}$ . The node decrements the timer so long as it senses the number of ongoing transmissions to be  $1, 2, \dots, L - 1$ . It freezes its timer if the sensed number of transmissions exceeds  $L - 1$  or the channel becomes idle. When the number of sensed transmissions again lies between 1 and  $L - 1$ , the backoff timer decrement is resumed from the last stored value. The node transmits its packet when its timer becomes zero.

As in conventional DCF, after the channel becomes idle, the AP waits for a short inter-frame space (SIFS) of duration  $T_{\text{SIFS}}$  and then sends a cumulative ACK of duration  $T_{\text{ACK}}$ , which acknowledges all the successful transmissions together. This is achieved by embedding in the MAC frame structure of the ACK, the addresses of all nodes whose packets the AP has successfully decoded [6], [14], [15]. Since  $T_{\text{DIFS}} > T_{\text{SIFS}}$ , the ACK gets priority over other transmissions when the channel is idle. However, unlike conventional DCF, a node must wait for all the other overlapping transmissions to end and only then expect the ACK to arrive within a timeout duration of  $T_{\text{OUT}} = T_{\text{DIFS}}$ . If an ACK does not arrive, the node times out, updates its contention window, chooses a new backoff timer

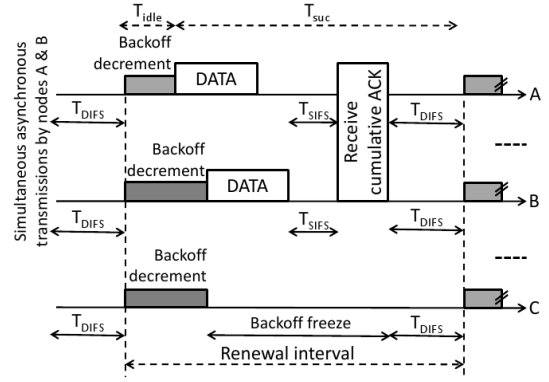

Fig. 2. Protocol 2 for  $L = 2$ : Timing diagram that shows a renewal interval in which two overlapping asynchronous transmissions to the AP occur. Node  $A$  transmits first. While  $A$  is transmitting,  $B$  and  $C$  continue decrementing their timers since there is only one ongoing transmission in the channel. Once  $B$  starts transmitting,  $C$  freezes its timer. Unlike Figure 1,  $C$ 's timer remains frozen even after  $A$ 's transmission ends. Only after the ACK and an idle period of duration  $T_{\text{DIFS}}$ , do all the nodes resume decrementing their timers. Thus, the ACK delay is reduced by restricting the number of successive overlapping transmissions.

value, and starts decrementing it. Figure 1 illustrates several aspects of this protocol for  $L = 2$ .

2) *Protocol 2*: We now propose a novel asynchronous MPR MAC protocol that differs from Protocol 1 with respect to the conditions under which a node freezes its backoff timer and keeps it frozen, and shall be the focus of the analysis in the paper. In it, a node freezes its backoff timer once the number of ongoing transmissions sensed by it either exceeds  $L - 1$  or decreases. Thereafter, it resumes decrementing its timer only when the channel has remained idle for a duration  $T_{\text{DIFS}}$ . The operation of the AP is the same as in Protocol 1, and is not repeated here.

Thus, in Protocol 2, no new packet transmissions can occur once the number of overlapping transmissions becomes greater than or equal to  $L$  or once a node completes the transmission of its packet. This reduces the delay incurred in receiving an ACK compared to Protocol 1, in which new transmissions can commence even after a node completes the transmission of its packet. This leads to a lower average head-of-line packet delay. As the saturation throughput and the head-of-line packet delay are inversely related (cf. Section III-C), the saturation throughput of the protocol exceeds that of Protocol 1. The protocol is illustrated in Figure 2 for  $L = 2$ .

The finite state machines that characterize the behavior of the AP and the nodes in Protocol 2 are shown in Figure 3 and Figure 4, respectively, for saturated traffic conditions.

**Remark** As in conventional DCF, virtual carrier sensing using the expected duration field in the packet header and the network allocation vector (NAV) can also be implemented in Protocol 2. When the number of ongoing transmissions increases, a node updates its NAV table using the expected duration field of the most recent packet that was transmitted.<sup>2</sup> A node can stop sensing the channel once the number of transmissions reaches  $L$  or it starts decreasing. Such virtual

<sup>2</sup>If multiple packet transmissions start at the same time, then the maximum of the expected duration fields of the packets is used by the sensing node.



carrier sensing is not as easy in Protocol 1, which allows new packet transmissions to start anytime so long as the total number of ongoing transmissions does not exceed  $L$ .

**Remark** In Protocol 2, channel estimation can be performed at the AP using training symbols in the preambles of each of the received data packets. The reader is referred to the extensive survey of channel estimation issues and techniques in [23] and to the discussion of MPR-specific channel estimation issues in [2]. In [24], it was shown that the asynchronous nature of the interference in the MPR MAC protocol even affects the optimal placement of pilots inside a packet. However, modeling and analyzing the effect of imperfect channel estimates is beyond the scope of the paper.

### III. ANALYSIS

We now analyze Protocol 2 in saturated traffic conditions in which the transmission queue at each node is always non-empty. Data loss due to packet errors is assumed to be negligible and a transmitted packet is assumed to be received successfully unless it is involved in a collision.

To get compact analytical results, we assume that the transmission duration of a data packet is  $\lambda$  slots, and that the transmission rate is fixed at  $\Omega$ , as has also been assumed in [18], [19]. Notice that fixed length packets cannot be easily analyzed using the Markovian approach of [16]. Extension to the scenario where the packet lengths are random is discussed at the end of this section. Further, we analyze the  $L = 2$  case, as was also done in [15]. The analysis can be extended to cover the general  $L \geq 2$  case. However, the expressions become more involved given the larger number of possible transmission scenarios that can occur. Due to space constraints and given the limited additional intuition provided by the general scenario, we do not discuss it in this paper.

As all the nodes use the same backoff parameters, their behaviors are statistically identical. Hence, we make the following decoupling approximations, which enable a fixed-point analysis [18], [19]:

- 1) Each transmitted packet suffers a collision with a probability  $\gamma$ , which is independent of all other nodes and does not depend on the number of its retransmissions. We shall refer to  $\gamma$  as the *conditional packet collision probability*.
- 2) Each node attempts a transmission in a slot in which it can transmit with a probability  $\beta$ , which is independent of all other nodes. We shall refer to  $\beta$  as the *attempt rate*.

*Node-specific renewal process:* Consider a given node, which we henceforth call the *tagged* node. Let  $A_j$  and  $B_j$  respectively denote the number of attempts and total backoff duration (in slots) needed by the tagged node to transmit its  $j^{\text{th}}$  packet. Let us consider the process formed by extracting only the times at which the tagged node is in its backoff phase, *i.e.*, it is decrementing its backoff timer. From the first assumption and the fact that the tagged node uses the same backoff parameters for all its packets, it can be inferred that the sequences  $(A_j)_{j \geq 1}$ ,  $(B_j)_{j \geq 1}$ , and  $(A_j, B_j)_{j \geq 1}$ , are all independent and identically distributed (i.i.d) [19]. Hence, the backoff process of a tagged node is a renewal process with renewal lifetimes

$B_j$ ,  $j \geq 1$ , and the renewal epochs are the time instants at which the node starts the final transmission of its  $j^{\text{th}}$  packet. If we consider  $A_j$ ,  $j \geq 1$ , as the reward gained at the  $j^{\text{th}}$  renewal interval, then from the renewal reward theorem [25], we have  $\beta = \frac{\mathbb{E}[A_j]}{\mathbb{E}[B_j]}$ , where  $\mathbb{E}[\cdot]$  denotes expectation.

*System-wide renewal process:* Consider the aggregate attempt process by all the  $n$  nodes. Due to the decoupling assumption, the aggregate attempt process is another renewal process. As shown in Figure 2, the renewal epochs of this process are the instants at which all the nodes start decrementing their backoff timers. For the rest of the paper, unless mentioned otherwise, the term renewal interval shall refer to the renewal interval of the system-wide renewal process.

Unlike conventional DCF, more than one packet can get transmitted in a renewal interval. We, therefore, first define the following terminology. *For  $j \in \{1, 2\}$ , a transmitted packet is called the  $j^{\text{th}}$  packet in a renewal interval if there are already  $j - 1$  ongoing packet transmissions in the channel when its transmission commences.*

**Lemma 1:** Given that a tagged node transmits in a renewal interval, the probability  $\alpha$  that its packet is the first packet in the renewal interval is  $\alpha = \frac{K_1(\beta)}{K_1(\beta) + K_2(\beta)}$ , where  $K_i(\beta)$  is the unconditional probability that the tagged node transmits the  $i^{\text{th}}$  packet in a renewal interval. Further,

$$K_1(\beta) = \frac{\beta}{1 - (1 - \beta)^n} \quad \text{and} \quad (1)$$

$$K_2(\beta) = \frac{(n - 1)\beta^2(1 - \beta)^{n-1}(1 - (1 - \beta)^{\lambda(n-1)})}{(1 - (1 - \beta)^n)(1 - (1 - \beta)^{n-1})}. \quad (2)$$

*Proof:* The proof is relegated to Appendix A. ■

Thus, given that a tagged node has transmitted in a renewal interval, the probability that its packet is the second packet in the renewal interval is  $1 - \alpha$ .

**Theorem 1:** The conditional packet collision probability,  $\gamma$ , as a function of  $\beta$  is given by

$$\gamma \triangleq \Gamma(\beta) = \alpha P_1(\beta) + (1 - \alpha) P_2(\beta), \quad (3)$$

where  $P_i(\beta)$ , for  $i = 1, 2$ , denotes the probability that a packet suffers a collision given that it is the  $i^{\text{th}}$  transmitted packet in a renewal interval. Further,

$$P_1(\beta) = \frac{(1 - (1 - \beta)^{n-1} - (n - 1)\beta(1 - \beta)^{n-2})}{1 - (1 - \beta)^{n-1}} \times \left(1 - (1 - \beta)^{\lambda(n-1)}\right), \quad (4)$$

$$P_2(\beta) = 1 - (1 - \beta)^{n-2}. \quad (5)$$

The attempt rate,  $\beta$ , as a function of  $\gamma$  is given by  $\beta \triangleq G(\gamma) = \frac{1 + \gamma + \gamma^2 + \dots + \gamma^K}{b_0 + \gamma b_1 + \gamma^2 b_2 + \dots + \gamma^K b_K}$ , where  $b_k = \frac{1}{2}(2^k \text{CW}_{\min} - 1)$ , for  $0 \leq k \leq K$ , denotes the mean backoff duration (in slots) before the  $(k + 1)^{\text{th}}$  transmission attempt of a packet.

*Proof:* The proof is relegated to Appendix B. ■

Hence, combining Lemma 1 and Theorem 1 results in the following fixed-point equation:

$$\gamma = \Gamma(G(\gamma)). \quad (6)$$

Since  $\Gamma(G(\gamma))$  is a continuous mapping in  $\gamma$  from the closed set  $[0, 1]$  to itself, Brouwer's fixed-point theorem [26] guarantees the existence of a fixed-point in the range. Solving this equation numerically yields  $\gamma$ . Then, Theorem 1 directly yields  $\beta$ .<sup>3</sup>

### A. Saturation Throughput

Let  $\zeta$  denote the amount of successfully transmitted data at the end of a renewal interval of duration  $T$ . From the renewal reward theorem [25], the saturation throughput,  $S$ , is given by  $S = \frac{\mathbb{E}[\zeta]}{\mathbb{E}[T]}$ . We now develop expressions for  $\mathbb{E}[\zeta]$  and  $\mathbb{E}[T]$ . As shown in Figure 2, a renewal interval of length  $T$  starts with an idle period of duration  $T_{\text{idle}}$ . It is followed by a busy period of length  $T_{\text{busy}}$ , in which one or more packets and a cumulative ACK (if success occurs) are transmitted. The busy period ends once the channel has been idle for the duration  $T_{\text{DIFS}}$ .

Depending on whether a success or a collision has occurred in the renewal interval, we refer to the busy time period following the idle period as a success period of duration  $T_{\text{suc}}$  or a collision period of duration  $T_{\text{col}}$ , respectively. Further, let  $T_{\text{col}}^{\text{min}}$  and  $T_{\text{suc}}^{\text{min}}$  denote the minimum values of  $T_{\text{col}}$  and  $T_{\text{suc}}$ , respectively. It can be seen that  $T_{\text{col}}^{\text{min}} = \lambda\delta + T_{\text{DIFS}}$ , which occurs when at least three packets of length  $\lambda\delta$  are transmitted simultaneously at the end of the idle period. Similarly, we have  $T_{\text{suc}}^{\text{min}} = \lambda\delta + T_{\text{SIFS}} + T_{\text{ACK}} + T_{\text{DIFS}}$ .

**Theorem 2:** The expected duration of the renewal interval is  $\mathbb{E}[T] = \mathbb{E}[T_{\text{idle}}] + D_{\text{col}} + D_{\text{suc}}$ , where  $D_{\text{col}}$  and  $D_{\text{suc}}$  are the contributions to the average busy period duration from the collision and success events, respectively. Further,  $\mathbb{E}[T_{\text{idle}}] = \frac{1}{1-(1-\beta)^n}$ ,

$$D_{\text{col}} = \left[ \frac{1 - (1-\beta)^n - n\beta(1-\beta)^{n-1}}{1 - (1-\beta)^n} - \frac{n(n-1)\beta^2(1-\beta)^{n-2}}{2(1 - (1-\beta)^n)} \right] T_{\text{col}}^{\text{min}} + \frac{n\beta(1-\beta)^{n-1} (1 - (1-\beta)^{n-1} - (n-1)\beta(1-\beta)^{n-2})}{(1 - (1-\beta)^n)(1 - (1-\beta)^{n-1})} \times \left[ (1 - (1-\beta)^{(\lambda-1)(n-1)}) T_{\text{col}}^{\text{min}} \right] + \frac{1 - (1-\beta)^{(\lambda-1)(n-1)} (\lambda - (\lambda-1)(1-\beta)^{n-1})}{(1 - (1-\beta)^{n-1})} \delta, \quad (7)$$

$$D_{\text{suc}} = \frac{n(n-1)\beta^2(1-\beta)^{n-2} + 2n\beta(1-\beta)^{\lambda(n-1)}}{2(1 - (1-\beta)^n)} T_{\text{suc}}^{\text{min}} + \frac{n(n-1)\beta^2(1-\beta)^{n-1}(1-\beta)^{n-2}}{(1 - (1-\beta)^n)(1 - (1-\beta)^{n-1})} \times \left[ (1 - (1-\beta)^{(\lambda-1)(n-1)}) T_{\text{suc}}^{\text{min}} \right] + \frac{1 - (1-\beta)^{(\lambda-1)(n-1)} (\lambda - (\lambda-1)(1-\beta)^{n-1})}{(1 - (1-\beta)^{n-1})} \delta. \quad (8)$$

<sup>3</sup>In our simulations, we have observed that the fixed-point is unique for the parameters of interest. However, proving uniqueness remains a challenging task.

The expected number of bits transmitted in a renewal interval is given by

$$\mathbb{E}[\zeta] = 2\lambda\delta\Omega \left( \frac{n(n-1)\beta^2(1-\beta)^{n-2}}{2(1 - (1-\beta)^n)} + \frac{n(n-1)\beta^2(1-\beta)^{n-2} [(1-\beta)^{n-1} - (1-\beta)^{\lambda(n-1)}]}{(1 - (1-\beta)^{n-1})(1 - (1-\beta)^n)} \right) + \lambda\delta\Omega \frac{n\beta(1-\beta)^{\lambda(n-1)}}{1 - (1-\beta)^n}. \quad (9)$$

*Proof:* The proof is relegated to Appendix C. ■

Hence, the expression for the saturation throughput follows directly from Theorem 2.

### B. Packet Dropping Probability

A packet is discarded by a node if it suffers  $K+1$  collisions. By our first decoupling approximation, a packet collides with a probability  $\gamma$ , which is independent of the number of its retransmission attempts. Consequently, the packet dropping probability is simply  $\gamma^{K+1}$ .

### C. Average Head-of-line Packet Delay

The average time spent by a packet in the head-of-queue position before it gets transmitted successfully or dropped after  $K+1$  failed transmission attempts is known as the *head-of-line packet delay*  $D$ .

To evaluate  $D$ , we first note that the packet dropping probability,  $\gamma^{K+1}$ , is small unless the channel is heavily congested. Therefore, almost all the packets are eventually successfully transmitted. Hence,  $D$  is approximately equal to the average time taken by a node to successfully transmit a packet. Since  $S$  is the saturation throughput (in bits) and each packet carries a payload of  $\Omega\lambda\delta$  bits, the number of data packets that are successfully transmitted per unit time is  $\frac{S}{\lambda\delta\Omega}$ . Thus, the number of successfully transmitted data packets per unit time per node is  $\frac{S}{n\lambda\delta\Omega}$ . Therefore, the average time required to successfully transmit a data packet is  $D \approx \frac{n\lambda\delta\Omega}{S}$ .

**Remark** The fixed-point analysis presented in this section can be extended to handle the scenario where the packet lengths are random variables. It can be shown that the general expressions for  $K_2(\beta)$  and  $P_1(\beta)$  are obtained by taking expectations of (2) and (5), respectively, with respect to the distribution of the packet lengths. The expressions for  $D_{\text{col}}$ ,  $D_{\text{suc}}$ , and  $\mathbb{E}[\zeta]$  can be derived similarly by summing over all possible realizations of packet lengths of the first and second packets in a renewal interval. All the other expressions remain unchanged.

## IV. EFFECT OF IMPERFECT CHANNEL ESTIMATION

Thus far, we have assumed that the nodes know the actual number of ongoing transmissions in the channel while going through their backoff phases. However, this needs to be estimated in practice. Several techniques have been developed in the literature for this purpose [27]. We discuss below a technique based on the eigen-decomposition of the correlation matrix of the signal received by the antenna array of a node.

The technique can be used if a node is equipped with an array of at least  $L$  antennas, which is easily feasible in WLANs today [28], [29].

Let a node be equipped with  $V \geq L$  antennas and let there be  $U$  ongoing transmissions in the channel. Also, let  $y_j(t)$ , for  $j = 1, \dots, V$ , denote the signal received at the  $j^{\text{th}}$  antenna of the node. Noises at different array elements are assumed to be uncorrelated with variance  $\sigma_n^2$ . The correlation matrix  $\mathbf{R}$  associated with the received signal vector  $\bar{\mathbf{y}}(t) = [y_1(t), \dots, y_V(t)]^T$  is defined as  $\mathbf{R} = \mathbb{E}[\bar{\mathbf{y}}(t)\bar{\mathbf{y}}^\dagger(t)]$ , where  $T$  and  $\dagger$  denote transpose and Hermitian transpose, respectively. It can be shown that if  $U < V$  then the smallest eigenvalue of  $\mathbf{R}$  is  $\sigma_n^2$  and it has an algebraic multiplicity of  $V - U$ . When  $U \geq V (\geq L)$ ,  $\mathbf{R}$  has no eigenvalues equal to  $\sigma_n^2$ . Thus, by evaluating the multiplicity of the eigenvalue of  $\mathbf{R}$  that is equal to the noise variance, a node can estimate whether the number of ongoing transmissions is  $0, 1, 2, \dots, L - 1$  or greater than or equal to  $L$ .

In practice, since  $\mathbf{R}$  itself is estimated by averaging a finite number of samples taken from the output of the antenna array, its smallest  $V - U$  eigenvalues need not be exactly equal to the noise variance. Several papers in the literature, e.g., [30]–[32], solve this problem using approaches based on nested sequence of hypothesis tests, information-theoretic criteria for model selection, and ranking and selection theory.

*Imperfect estimation model:* A key thing to take away from this discussion is that the presence of noise and channel propagation effects can occasionally make a node incorrectly estimate the number of ongoing transmissions in the channel. This clearly affects the performance of the asynchronous MPR protocols, whose multiple access rules use this estimate. We model imperfect estimation as follows. With probability  $p_{i,j}$ , a node estimates that there  $j$  ongoing transmissions while there actually are  $i$ .<sup>4</sup> We make the following simplifying assumptions: (1) A node makes an error independent of the other nodes. This is justifiable since the channel fades and noise encountered by the different nodes are independent. (2) Once a node estimates the number of transmissions in a slot, its estimate does not change until the transmitters or the number of transmissions actually change. This captures the fact that deep fades are primarily responsible for incorrect estimation. (3) A node perfectly estimates whether the channel is idle or not, i.e.,  $p_{0,j} = p_{j,0} = 0$ , for all  $j \geq 1$ . Similarly, the odds that a node's estimate of the number of ongoing transmissions is incorrect by more than one are assumed to be negligible, i.e.,  $p_{i,j} = 0$  if  $|j - i| \geq 2$  for all  $i \in \mathbb{Z}^+$ . We shall also assume that  $p_{L-1,L} = 0$ . This intuitive model, while not general, provides a tractable method to analyze the effect of imperfect estimates, while capturing the essence of the problem.

As before, we analyze below the  $L = 2$  case. The main problem that now arises is that a node can erroneously estimate the number of ongoing transmissions to be one, while there are actually two. It, therefore, will continue to decrement its

<sup>4</sup>This abstraction presents a refined probabilistic model for the classical hidden nodes problem that arises in conventional DCF, in which the nodes that incorrectly estimate that the number of ongoing transmissions is zero are treated as hidden nodes.

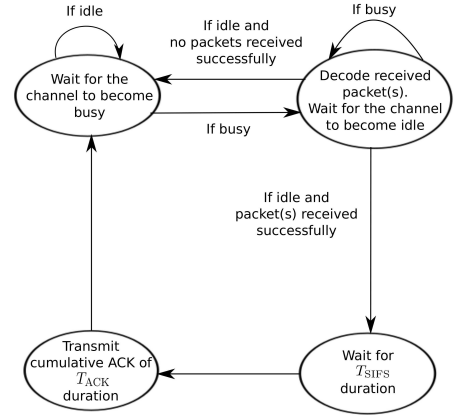

Fig. 3. Protocol 2: Finite state machine for the access point.

timer and eventually it may transmit and cause a collision.

#### A. Analysis with Imperfect Estimation of Number of Transmitters

As in Section III, we use the two classical decoupling approximations. To distinguish from the perfect estimation case, we shall denote the attempt rate by  $\tilde{\beta}$  and the conditional packet collision probability by  $\tilde{\gamma}$ . It can be shown that  $\tilde{\beta} = G(\tilde{\gamma})$ , where  $G(\cdot)$  is as defined in Theorem 1.

We now consider the system-wide renewal process. Due to imperfect estimation, a third, and, in general, a  $j^{\text{th}}$  packet, for  $j \geq 3$ , can be transmitted in a renewal interval. The  $j^{\text{th}}$  packet in a renewal interval, for  $j \geq 3$ , is defined as a packet whose transmission commences erroneously when  $j - 1$  nodes have already commenced transmission in the interval.

The erroneous third packet transmission can start, for example, when the previous two transmissions are still ongoing in the channel. It can also start after the number of transmissions decreases from two to one. This is because the nodes, which had erroneously estimated two transmissions to be one, cannot detect this decrease and continue to decrement their timers. However, the latter scenario is less probable because for it to happen the erroneous node must have a sufficiently large backoff timer value to decrement even after the completion of the first packet's transmission. In Protocol 2, when the estimation error is small, collisions occur rarely, which makes it less likely for a node to have a large enough contention window. Therefore, we ignore this case and all cases that involve more than one erroneous packet transmissions in a renewal interval.

In order to write compact analytical expressions, we first define the function  $\Theta : \mathbb{Z}^+ \rightarrow \mathbb{R}^+$  as  $\Theta(t) = p_{2,1}(1 - \tilde{\beta})^t + 1 - p_{2,1}$ . It denotes the probability that a node does not transmit during the  $t$  slots in which there are already two ongoing transmissions in the channel.

**Lemma 2:** Given that a tagged node transmits in a renewal interval, the probability  $\tilde{\alpha}_i$  that the packet transmitted by the tagged node is the  $i^{\text{th}}$  packet in the interval is given by

$$\tilde{\alpha}_i = \frac{\tilde{K}_i(\tilde{\beta})}{\tilde{K}_1(\tilde{\beta}) + \tilde{K}_2(\tilde{\beta}) + \tilde{K}_3(\tilde{\beta})}, \quad (10)$$

where  $\tilde{K}_i(\tilde{\beta})$ , for  $i = 1, 2, 3$ , is the unconditional probability that a tagged node transmits the  $i^{\text{th}}$  packet in a renewal interval. Furthermore,  $\tilde{K}_1(\tilde{\beta}) = K_1(\tilde{\beta})$ ,  $\tilde{K}_2(\tilde{\beta}) = K_2(\tilde{\beta})$ , and

$$\begin{aligned} \tilde{K}_3(\tilde{\beta}) &= \frac{n(n-1)\tilde{\beta}^3(1-\tilde{\beta})^{n-2}}{2(1-(1-\tilde{\beta})^n)} \sum_{i=0}^{\lambda-2} p_{2,1}(1-\tilde{\beta})^i \Theta^{n-3}(i) \\ &\quad + \frac{(n-1)(n-2)\tilde{\beta}^3(1-\tilde{\beta})^{2n-3}}{1-(1-\tilde{\beta})^n} \\ &\quad \times \sum_{i=0}^{\lambda-3} \sum_{j=0}^{\lambda-i-3} (1-\tilde{\beta})^{i(n-1)+j} p_{2,1} \Theta^{n-3}(j). \end{aligned} \quad (11)$$

Recall that  $K_1(\cdot)$  and  $K_2(\cdot)$  are defined in Lemma 1.

*Proof:* The proof is relegated to Appendix D. ■

**Theorem 3:** The packet collision probability,  $\tilde{\gamma}$ , in terms of the attempt rate,  $\tilde{\beta}$ , is given by

$$\tilde{\gamma} \triangleq \tilde{\Gamma}(\tilde{\beta}) = \tilde{\alpha}_1 \tilde{P}_1(\tilde{\beta}) + \tilde{\alpha}_2 \tilde{P}_2(\tilde{\beta}) + \tilde{\alpha}_3 \tilde{P}_3(\tilde{\beta}), \quad (12)$$

where  $\tilde{\alpha}_i$ , for  $i = 1, 2, 3$ , are given by Lemma 2. Here,  $\tilde{P}_i(\tilde{\beta})$  denotes the probability that a packet suffers a collision given that it is the  $i^{\text{th}}$  transmitted packet in a renewal interval. Further,

$$\begin{aligned} \tilde{P}_1(\tilde{\beta}) &= P_1(\tilde{\beta}) + (n-1)\tilde{\beta}(1-\tilde{\beta})^{n-2} \\ &\quad \times \sum_{i=0}^{\lambda-1} (1-\tilde{\beta})^{i(n-1)} (1-\Theta^{n-2}(\lambda-i-1)), \end{aligned} \quad (13)$$

$$\begin{aligned} \tilde{P}_2(\tilde{\beta}) &= P_2(\tilde{\beta}) + \frac{(1-(1-\tilde{\beta})^{n-1})(1-\tilde{\beta})^{n-2}}{1-(1-\tilde{\beta})^{(\lambda-1)(n-1)}} \\ &\quad \times \sum_{i=0}^{\lambda-2} (1-\tilde{\beta})^{i(n-1)} (1-\Theta^{n-2}(\lambda-i-2)), \end{aligned} \quad (14)$$

and  $\tilde{P}_3(\tilde{\beta}) = 1$ . Recall that  $P_1(\cdot)$  and  $P_2(\cdot)$  are defined in Theorem 1.

*Proof:* The proof is relegated to Appendix E. ■

Hence, by combining (12) and  $\tilde{\beta} = G(\tilde{\gamma})$ , we obtain the desired fixed-point equation in  $\gamma$ . As in ideal channel estimation, the existence of a solution in  $[0, 1]$  is guaranteed by the Brouwer's fixed-point theorem [26]. A proof of uniqueness again remains a challenging problem.

## B. Throughput

As in Section III-A, it can be shown that the saturation throughput with imperfect estimation is  $S = \frac{\mathbb{E}[\zeta]}{\mathbb{E}[T]}$ . We now evaluate  $\mathbb{E}[T]$  and  $\mathbb{E}[\zeta]$ .

1) *Evaluating  $\mathbb{E}[T]$ :* Recall from Lemma 2 that  $\mathbb{E}[T] = \mathbb{E}[T_{\text{idle}}] + D_{\text{col}} + D_{\text{suc}}$ . As before,  $\mathbb{E}[T_{\text{idle}}] = \frac{1}{1-(1-\tilde{\beta})^n}$ . We now derive expressions for  $D_{\text{suc}}$  and  $D_{\text{col}}$ .

*Evaluating  $D_{\text{suc}}$ :* Clearly,  $T_{\text{busy}} = T_{\text{suc}}^{\min}$  when: (i) only one node transmits in the renewal interval, or (ii) exactly two nodes start transmitting simultaneously at the end of the idle period and no other transmissions occur subsequently. Exactly two nodes can do so only when each of the remaining  $n-2$  nodes either does not make an error, or makes an error but does not transmit during the remaining  $\lambda-1$  slots of the first two packets. The probability of this event is

$(p_{2,1}(1-\tilde{\beta})^{\lambda-1} + 1 - p_{2,1})^{n-2} = \Theta^{n-2}(\lambda-1)$ . We then have

$$\begin{aligned} \Pr [T_{\text{busy}} = T_{\text{suc}}^{\min}] &= \frac{n\tilde{\beta}(1-\tilde{\beta})^{\lambda(n-1)}}{1-(1-\tilde{\beta})^n} \\ &\quad + \frac{\binom{n}{2}\tilde{\beta}^2(1-\tilde{\beta})^{n-2}}{1-(1-\tilde{\beta})^n} \Theta^{n-2}(\lambda-1). \end{aligned} \quad (15)$$

The denominator term  $1-(1-\tilde{\beta})^n$  arises because of conditioning on the event that the idle period has already ended. Similarly,  $T_{\text{busy}} = T_{\text{suc}}^{\min} + k\delta$  when the first and second transmissions in a renewal interval start  $1 \leq k \leq \lambda-1$  slots apart and no other transmission occurs subsequently. It can be shown that

$$\begin{aligned} \Pr [T_{\text{suc}} = T_{\text{suc}}^{\min} + k\delta] &= \frac{n(n-1)\tilde{\beta}^2(1-\tilde{\beta})^{k(n-1)}}{1-(1-\tilde{\beta})^n} \\ &\quad \times (1-\tilde{\beta})^{n-2} \Theta^{n-2}(\lambda-1-k). \end{aligned} \quad (16)$$

*Evaluating  $D_{\text{col}}$ :* Along similar lines,  $T_{\text{busy}} = T_{\text{col}}^{\min}$  when at least three among  $n$  nodes start transmitting simultaneously at the end of the idle period. The probability of this event is

$$\begin{aligned} \Pr [T_{\text{busy}} = T_{\text{col}}^{\min}] &= \frac{1-(1-\tilde{\beta})^n - n\tilde{\beta}(1-\tilde{\beta})^{n-1}}{1-(1-\tilde{\beta})^n} \\ &\quad - \frac{\binom{n}{2}\tilde{\beta}^2(1-\tilde{\beta})^{n-2}}{1-(1-\tilde{\beta})^n}. \end{aligned} \quad (17)$$

Again,  $T_{\text{busy}} = T_{\text{col}}^{\min} + k\delta$  when: (i) Exactly two of the  $n$  nodes transmit the first packet in a renewal interval and the third packet is transmitted erroneously after  $k$  slots by at least one of the remaining  $n-2$  nodes, which can be shown to occur with probability  $\Theta^{n-2}(k-1) - \Theta^{n-2}(k)$ ; or (ii) the first packet is transmitted by a single node, and after  $k$  slots at least two of the remaining nodes transmit simultaneously; or (iii) the first and second packets are transmitted  $l$  slots ( $1 \leq l \leq k-1$ ) apart, and the third erroneous transmission occurs  $k$  slots after the first transmission. The probabilities of these events can be calculated in a manner similar to that discussed above. It can be shown that

$$\begin{aligned} \Pr [T_{\text{busy}} = T_{\text{col}}^{\min} + k\delta] &= \frac{\binom{n}{2}\tilde{\beta}^2(1-\tilde{\beta})^{n-2}}{1-(1-\tilde{\beta})^n} \\ &\quad \times (\Theta^{n-2}(k-1) - \Theta^{n-2}(k)) + \frac{n(n-1)\tilde{\beta}^2(1-\tilde{\beta})^{n-2}}{1-(1-\tilde{\beta})^n} \\ &\quad \times \left[ \sum_{l=1}^{k-1} (1-\tilde{\beta})^{l(n-1)} (\Theta^{n-2}(k-l-1) - \Theta^{n-2}(k-l)) \right] \\ &\quad + \frac{n\tilde{\beta}(1-\tilde{\beta})^{k(n-1)}}{1-(1-\tilde{\beta})^n} (1-(1-\tilde{\beta})^{n-1} - (n-1)\tilde{\beta}(1-\tilde{\beta})^{n-2}). \end{aligned} \quad (18)$$

Combining the above results yields the expressions for  $D_{\text{suc}}$  and  $D_{\text{col}}$ , and, hence,  $\mathbb{E}[T]$ .

2) *Evaluating  $\mathbb{E}[\zeta]$ :* As in ideal channel estimation,  $\zeta$  equals 0,  $\lambda\delta\Omega$ , or  $2\lambda\delta\Omega$  when 0, 1 or 2 packets, respectively,





Fig. 4. Protocol 2: Finite state machine for a node under saturated traffic condition.

are successfully transmitted in a renewal interval. The probabilities of these events are given in (15) and (16). Hence,

$$\begin{aligned} \mathbb{E}[\zeta] &= \lambda\delta\Omega \frac{n\tilde{\beta}(1-\tilde{\beta})^{\lambda(n-1)}}{1-(1-\tilde{\beta})^n} + 2\lambda\delta\Omega \\ &\quad \times \frac{\binom{n}{2}\tilde{\beta}^2(1-\tilde{\beta})^{n-2}}{1-(1-\tilde{\beta})^n} \Theta^{n-2}(\lambda-1) \\ &+ 2\lambda\delta\Omega \sum_{k=1}^{\lambda-1} \frac{n(n-1)\tilde{\beta}^2(1-\tilde{\beta})^{k(n-1)}(1-\tilde{\beta})^{n-2}}{1-(1-\tilde{\beta})^n} \\ &\quad \times \Theta^{n-2}(\lambda-1-k). \quad (19) \end{aligned}$$

## V. NUMERICAL RESULTS

TABLE I  
SIMULATION PARAMETERS

Parameter	Notation	Values
Slot duration	$\delta$	20 $\mu$ s
DIFS duration	$T_{\text{DIFS}}$	50 $\mu$ s
SIFS duration	$T_{\text{SIFS}}$	10 $\mu$ s
Minimum contention window size	$CW_{\text{min}}$	32
Maximum contention window size	$CW_{\text{max}}$	1024
Maximum number of transmissions	$K+1$	8
Packet length	$\lambda$	400 slots
ACK duration (with PHY header)	$T_{\text{ACK}}$	304 + 48(L-1) $\mu$ s

We now present the results obtained from Monte Carlo simulations that use 50000 samples. An event-driven platform written in the C programming language was built for simulating the MPR protocols, and provides an independent verification of the analytical results. The platform implements the finite state machines of the AP and the nodes that are

shown in Figures 3 and 4, respectively. Virtual carrier sensing is not implemented since it does not affect the performance metrics under consideration. The parameter values used in the simulations are listed in Table I. The ACK frame length is increased by 6-bytes for each extra receiver address field to incorporate MPR. We shall vary some of the parameters over a wide range to investigate the sensitivity of the asynchronous MPR MAC protocols to them.

### A. Ideal Estimation

Figure 5 plots the saturation throughput,  $S/\Omega$ , as a function of the number of nodes,  $n$ , for conventional DCF, Protocol 1, and Protocol 2. The results are shown for different values of  $L$ . We observe a good match between the analysis and simulation results for the  $L=2$  case. We also see that the saturation throughput of Protocol 2 is close to  $L$  times that of conventional DCF and is 10-30% more than that of Protocol 1. Allowing for variable packet lengths in the model could make MPR even more rewarding. Similar results are obtained in Figure 6, which plots the average head-of-line packet delay of the protocols as a function of  $n$  for various  $L$ . This figure shows that the head-of-line packet delay,  $D$ , increases almost linearly with the number of nodes,  $n$ . This can be explained by the relation derived in Section III-C and the fact that saturation throughput varies slowly with  $n$ . We see that the head-of-line packet delay decreases as  $L$  increases. This is because, for larger  $L$ , more transmission opportunities are available for a node. This more than compensates for the additional delay caused by more overlapping transmissions in a renewal interval.

To investigate the effect of packet lengths on the performance of the protocols, we plot in Figure 7 the saturation throughputs of Protocols 1 and 2 as a function of the packet length,  $\lambda$ , for different values of  $L$ . We again see that Protocol 2 outperforms Protocol 1 for a wide range of packet lengths and for all  $L$ . We also observe that for large packet lengths, the saturation throughputs of both protocols become almost constant. This can be explained from (7), (8), and (9) as follows: As  $\lambda$  becomes large the exponential terms containing  $\lambda$  in the expressions for  $D_{\text{col}}$ ,  $D_{\text{suc}}$ , and  $\mathbb{E}[\zeta]$  become negligible. Hence, both  $\mathbb{E}[T]$  and  $\mathbb{E}[\zeta]$  increase linearly with  $\lambda$ . Thus, their ratio, which is the saturation throughput, becomes almost constant.

We delve into the inner workings of the protocols in Figure 8, which plots the conditional packet collision probability,  $\gamma$ , as a function of  $n$  for Protocol 1, Protocol 2 and conventional DCF. As expected,  $\gamma$  increases with  $n$ . We observe that the collision probability of Protocol 2 is less than that of Protocol 1 and conventional DCF for all  $n$ . Notice that the analysis and simulation results for Protocol 2 match each other well, which validates the fixed-point analysis. As  $n$  increases, the relative error between analysis and simulation decreases. This is in consonance with the results in mean field interaction theory [33].

Figure 9 plots the packet dropping probability of Protocol 2 as a function of the number of nodes for different values of  $K$  and for  $L=2$ . For fixed  $n$ , the packet dropping

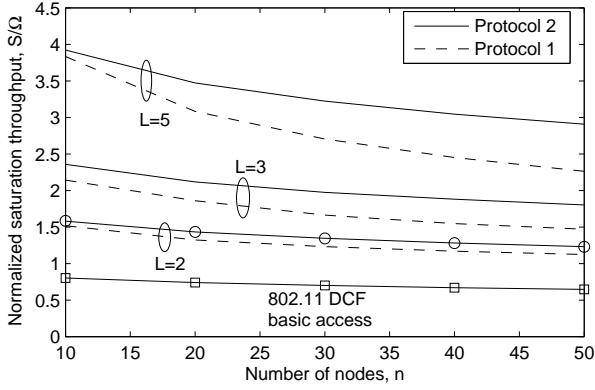

Fig. 5. Saturation throughput as a function of the number of nodes for different values of  $L$ . Analysis results for  $L = 2$  for Protocol 2 are shown using circles (o).

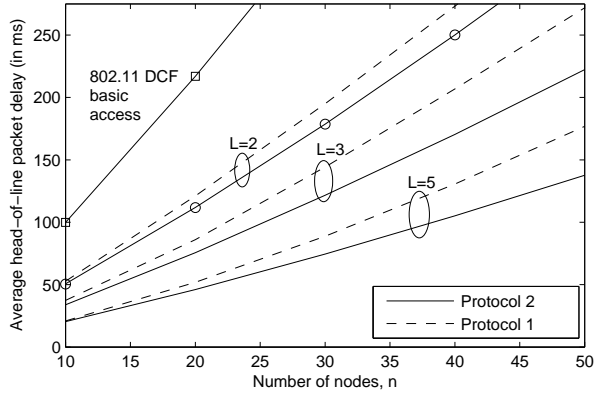

Fig. 6. Head-of-line average delay per packet as a function of the number of nodes for different values of  $L$ . Analysis results for  $L = 2$  for Protocol 2 are shown using circles (o).

probability decreases as  $K$  increases. This is because for fixed  $n$  the collision probability  $\gamma$  remains constant. Hence, as  $K$  increases, the packet dropping probability  $\gamma^{K+1}$  decreases. Note that for  $K \geq 4$ , the packet dropping probability is less than 5% even with 50 nodes.

### B. Imperfect Estimation

To investigate the effect of imperfect estimation of number of transmitters, we set  $p_{2,1} = p_{3,2} = \dots = p_{L,L-1} = p$ . In Figure 10, we plot the saturation throughput of Protocol 1, Protocol 2, and the synchronous MPR MAC protocol as a function of  $p$  for different values of  $L$ . Notice that the saturation throughput of Protocol 2 decreases by only 9% when  $p$  increases ten-fold from 0.001 to 0.01. Thus, Protocol 2 is robust to estimation errors. Protocol 1 also shows a similar sensitivity levels to the estimation errors. Further, for  $L = 2$ , we see a good match between the analysis and simulation results. The saturation throughput of the synchronous protocol does not depend on the  $p$  because in it a node does not need to estimate the number of ongoing transmissions. Eventually, for large enough  $p$ , the saturation throughput of Protocol 2 falls below that of the synchronous protocol. The cross-over point

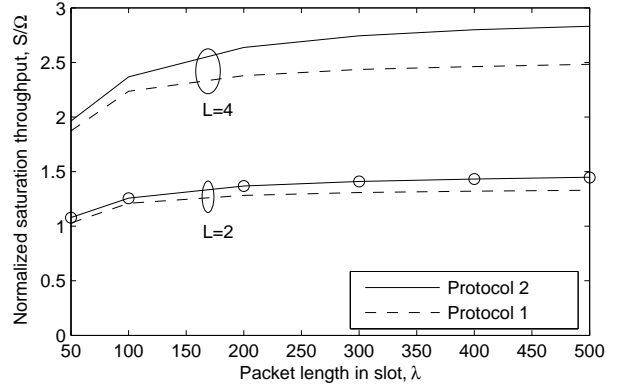

Fig. 7. Saturation throughput as a function of the packet length for different values of  $L$ . Analysis results for  $L = 2$  for Protocol 2 are shown using circles (o).

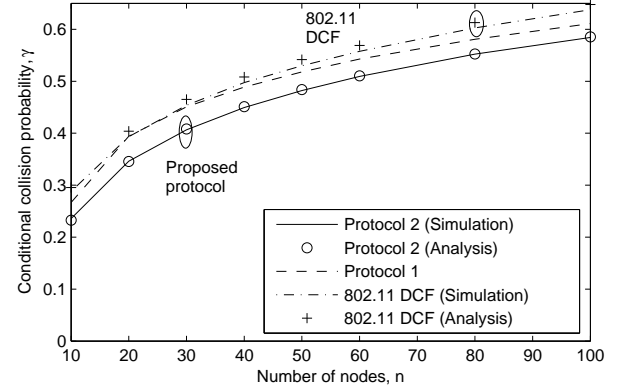

Fig. 8. Conditional packet collision probability as a function of the number of nodes ( $L = 2$ ).

increases with  $L$ .

Figure 11 focuses on  $L = 2$  and plots the attempt rate,  $\tilde{\beta}$ , as a function of  $n$  for different values of  $p_{2,1}$ . We again observe a good match between the analytical and simulation results. We see that the attempt rate decreases as  $p_{2,1}$  increases, which happens because the collision probability,  $\tilde{\gamma}$ , increases and the contention window size increases. The increase in the contention window size also explains the minor mismatch between the analytical and simulation results in the above two figures arises for larger  $p$  for  $L = 2$ .

## VI. CONCLUSIONS

We saw that an asynchronous MPR MAC protocol that uses carrier sensing in conjunction with the backoff timer mechanism is inherently distributed in nature and harnesses the MPR capability well. However, ACK delays degrade the performance of such an asynchronous protocol because the nodes determine their contention window sizes depending on whether they have received an ACK or not. We showed that the conditions under which a node should freeze its timer affect the ACK delays, and proposed a rule that reduces the delay and increases the overall system throughput. We also developed a renewal-theoretic fixed-point analysis of the MPR

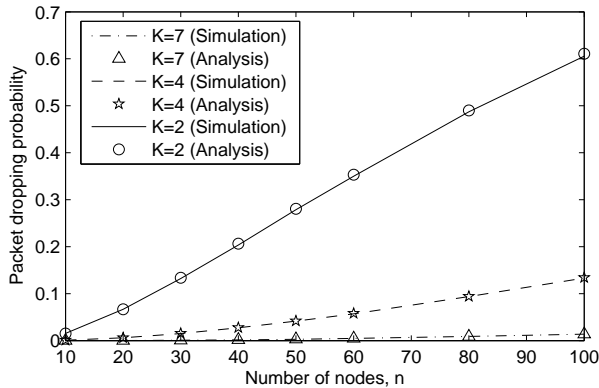

Fig. 9. Packet dropping probability as a function of number of nodes for different settings of maximum number of retransmissions ( $L = 2$ ).

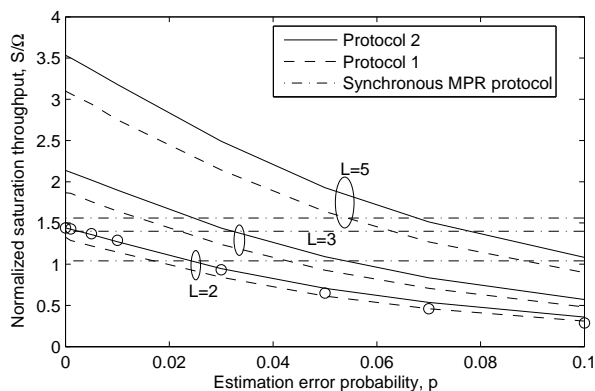

Fig. 10. Imperfect estimation scenario: Normalized saturation throughput as a function of estimation error probability for different values of  $L$ . Analysis results for  $L = 2$  for Protocol 2 are shown using circles ( $\circ$ ).

protocol. The analysis was generalized to the practical scenario where a node may incorrectly estimate the number of ongoing transmissions. We saw that the asynchronous MPR protocols are quite robust to such errors.

Several interesting avenues for future work exist such as characterizing the non-saturation behavior of the protocol and

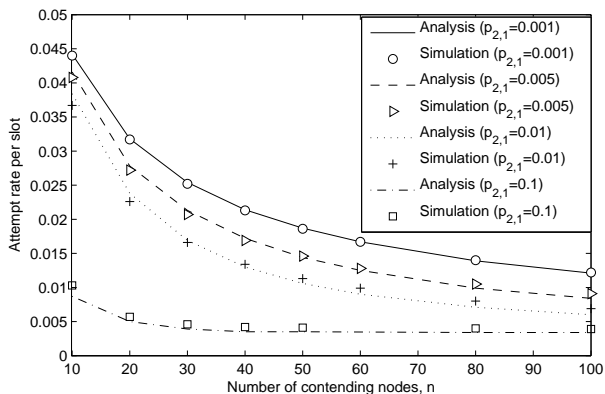

Fig. 11. Imperfect estimation scenario: Attempt rate as a function of the number of nodes ( $L = 2$ ).

its impact on the performance of higher layers of the protocol stack. While we focused primarily on the single receiver scenario, extension of the protocols to the scenario where multiple transmitter-receiver pairs are simultaneously active, is also an interesting topic for future research. In this case, the ACK handling depends on the physical layer and is affected by antenna systems, channel rank, coding, and network topology.

## APPENDIX

### A. Proof of Lemma 1

*Expression for  $K_1(\beta)$ :* Let the tagged node's transmission in slot  $t$  ( $t \geq 1$ ) of the renewal interval be the first transmission in the renewal interval. This occurs with probability  $(1 - \beta)^{n(t-1)}\beta$ , since none of the  $n$  nodes should have transmitted in the slots  $1, \dots, t-1$  and the tagged node should transmit in slot  $t$ . Hence,  $K_1(\beta) = \sum_{t=1}^{\infty} \beta(1 - \beta)^{n(t-1)} = \frac{\beta}{1 - (1 - \beta)^n}$ .

*Expression for  $K_2(\beta)$ :* Let the first transmission from a node other than the tagged node begin in slot  $t_1$  of the renewal interval, where  $t_1 \geq 1$ , and let the tagged node transmit in slot  $t_1 + t_2 + 1$ . Clearly,  $0 \leq t_2 \leq \lambda - 2$ , since the Protocol 2 does not permit any node to transmit once the channel becomes idle. The probability of this individual event is  $(1 - \beta)^{n(t_1-1)}(n-1)\beta(1 - \beta)^{n-2}(1 - \beta)(1 - \beta)^{(n-1)t_2}\beta$ . Summing the probabilities over  $t_1$  and  $t_2$  yields the desired expression for  $K_2(\beta)$ .

The expression for  $\alpha$  in terms of  $K_1(\beta)$  and  $K_2(\beta)$  then follows from Baye's rule.

### B. Proof of Theorem 1

1) *Evaluation of  $\Gamma(\beta)$ :* The expression for  $\gamma$  follows directly from the definitions of  $\alpha$ ,  $P_1(\beta)$ , and  $P_2(\beta)$ , and the law of total probability.

*Evaluating  $P_1(\beta)$ :* Let the packet transmitted by a tagged node be the first packet in a renewal interval. It suffers a collision only if, in any of its  $\lambda$  transmission slots, at least two among the remaining  $n-1$  nodes transmit. In our protocol, this can happen only when these nodes commence transmissions in the same slot. The probability that the first  $i$  slots,  $0 \leq i \leq \lambda-1$ , of the transmitted packet are free of collision is  $(1 - \beta)^{i(n-1)}$ . And, the probability that two or more nodes transmit in the  $(i+1)^{\text{th}}$  slot is  $1 - (1 - \beta)^{n-1} - (n-1)\beta(1 - \beta)^{n-2}$ . Thus, we have  $P_1(\beta) = \sum_{i=0}^{\lambda-1} (1 - \beta)^{i(n-1)} (1 - (1 - \beta)^{n-1} - (n-1)\beta(1 - \beta)^{n-2})$ , which simplifies to (5).

*Evaluating  $P_2(\beta)$ :* If the packet transmitted by a tagged node is the second packet in a renewal interval, then it suffers a collision only if at least one among the remaining  $n-2$  nodes transmits in the same slot as the tagged node. The probability of this event is  $P_2(\beta) = 1 - (1 - \beta)^{n-2}$ .

2) *Evaluation of  $G(\gamma)$ :* The expression for  $G(\gamma)$  is based on the node-specific renewal process and follows directly from the equation  $\beta = \frac{\mathbb{E}[A_i]}{\mathbb{E}[B_j]}$ . Its derivation is along lines similar to that in [19] for conventional DCF. It is, therefore, skipped in order to conserve space.

### C. Proof of Theorem 2

1) *Evaluation of  $\mathbb{E}[T]$* : A renewal interval of length  $T$  consists of an idle period of duration  $T_{\text{idle}}$  followed by a busy period, which is either a collision or a success. Therefore,  $\mathbb{E}[T] = \mathbb{E}[T_{\text{idle}}] + D_{\text{col}} + D_{\text{suc}}$ . Here,  $D_{\text{col}} = \mathbb{E}[T_{\text{busy}}I[T_{\text{col}} > 0]]$  and  $D_{\text{suc}} = \mathbb{E}[T_{\text{busy}}I[T_{\text{suc}} > 0]]$ , where  $I[\omega]$  denotes an indicator function that equals 1 if  $\omega$  is true and is 0 otherwise.

*Expression for  $\mathbb{E}[T_{\text{idle}}]$* : A slot is idle with a probability  $(1 - \beta)^n$  as none among the  $n$  nodes should transmit in it. Thus,  $\Pr[T_{\text{idle}} > t] = (1 - \beta)^{nt}$ , for  $t = 0, 1, \dots$ . Hence,

$$\mathbb{E}[T_{\text{idle}}] = \sum_{t=0}^{\infty} \Pr[T_{\text{idle}} > t] = \sum_{t=0}^{\infty} (1 - \beta)^{nt} = \frac{1}{1 - (1 - \beta)^n}. \quad (20)$$

*Expression for  $D_{\text{col}}$* : Clearly,  $T_{\text{busy}} = T_{\text{col}}^{\text{min}}$  when at least three nodes commence transmissions simultaneously at the end of the idle period and, thus, collide. This occurs with probability  $\frac{1 - (1 - \beta)^n - n\beta(1 - \beta)^{n-1} - \binom{n}{2}\beta^2(1 - \beta)^{n-2}}{1 - (1 - \beta)^n}$ . The denominator is due to the conditioning on the fact that the idle period has already ended and, therefore, at least one node has transmitted. Now,  $T_{\text{busy}} = T_{\text{col}}^{\text{min}} + k\delta$ , for  $1 \leq k \leq \lambda - 1$ , when one among  $n$  nodes starts transmitting after the idle period, none among the remaining  $n - 1$  nodes transmit in the next  $k - 1$  slots, and then at least two among these  $n - 1$  nodes simultaneously commence transmission in the next slot. This occurs with probability  $\frac{n\beta(1 - \beta)^{n-1}(1 - \beta)^{(k-1)(n-1)}(1 - (1 - \beta)^{n-1} - (n-1)\beta(1 - \beta)^{n-2})}{1 - (1 - \beta)^n}$ . Combining the terms for the collision events yields  $D_{\text{col}} = \sum_{k=0}^{\lambda-1} \Pr[T_{\text{busy}} = T_{\text{col}}^{\text{min}} + k\delta] (T_{\text{col}}^{\text{min}} + k\delta)$ , which simplifies to (8).

*Expression for  $D_{\text{suc}}$* : Similarly,  $T_{\text{busy}} = T_{\text{suc}}^{\text{min}}$  when: (i) exactly one node transmits in the renewal interval and none of the  $n - 1$  nodes transmit thereafter, which occurs with probability  $\frac{n\beta(1 - \beta)^{n-1}}{1 - (1 - \beta)^n} (1 - \beta)^{(n-1)(\lambda-1)}$ , or (ii) exactly two nodes start transmitting simultaneously just after the idle period is over, which occurs with probability  $\frac{\binom{n}{2}\beta^2(1 - \beta)^{n-2}}{1 - (1 - \beta)^n}$ .

Now,  $T_{\text{busy}} = T_{\text{suc}}^{\text{min}} + k\delta$ , for  $1 \leq k \leq \lambda - 1$ , when exactly one among  $n$  nodes starts transmitting after the idle period, during the next  $k - 1$  slots none among the  $n - 1$  nodes transmit, and finally exactly one among the  $n - 1$  nodes transmits in the next slot. This happens with probability  $\frac{n\beta(1 - \beta)^{n-1}(1 - \beta)^{(k-1)(n-1)}(n-1)\beta(1 - \beta)^{n-2}}{1 - (1 - \beta)^n}$ . Combining the above success terms, we get  $D_{\text{suc}} = \sum_{k=0}^{\lambda-1} \Pr[T_{\text{busy}} = T_{\text{suc}}^{\text{min}} + k\delta] (T_{\text{suc}}^{\text{min}} + k\delta)$ , which simplifies to (8).

2) *Evaluation of  $\mathbb{E}[\zeta]$* : In a renewal interval,  $\zeta = 0$  if a collision occurs,  $\zeta = \lambda\delta\Omega$  if exactly one node successfully transmits, and  $\zeta = 2\lambda\delta\Omega$  when exactly two nodes successfully transmit. The probabilities of these events were derived while computing  $\mathbb{E}[T]$  above. Hence,

$$\mathbb{E}[\zeta] = \frac{n\beta(1 - \beta)^{\lambda(n-1)}}{1 - (1 - \beta)^n} \lambda\delta\Omega + \left( \frac{\binom{n}{2}\beta^2(1 - \beta)^{n-2}}{1 - (1 - \beta)^n} + \sum_{k=1}^{\lambda-1} \frac{n(n-1)\beta^2(1 - \beta)^{n-2}(1 - \beta)^{k(n-1)}}{1 - (1 - \beta)^n} \right) 2\lambda\delta\Omega. \quad (21)$$

This upon simplification results in (9).

### D. Brief Proof of Lemma 2

The derivations of  $\tilde{K}_1(\tilde{\beta})$  and  $\tilde{K}_2(\tilde{\beta})$  are the same as that for  $K_1(\beta)$  and  $K_2(\beta)$ , respectively, in Appendix A. For evaluating  $\tilde{K}_3(\tilde{\beta})$ , we consider the following two cases that may arise when the tagged node transmits the third packet in a renewal interval while the previous two transmissions are still ongoing in the channel. As mentioned, the probability of the case where the third packet transmission commences after the first packet transmission has ended is smaller and is neglected.

*Case 1*: Two nodes, excluding the tagged one, start transmitting simultaneously the first two packets in the renewal interval, which occurs with probability  $\frac{\binom{n-1}{2}\tilde{\beta}^2(1 - \tilde{\beta})^{n-2}}{1 - (1 - \tilde{\beta})^n}$ . Then, in the subsequent slots, the tagged node and  $x$  other nodes ( $0 \leq x \leq n - 3$ ) that have not yet transmitted, erroneously estimate the number of ongoing transmissions in the channel to be one, which occurs with probability  $\binom{n-3}{x} p_{2,1}^{x+1} (1 - p_{2,1})^{n-3-x}$ . None of these  $x + 1$  nodes transmits for  $i$  slots ( $0 \leq i \leq \lambda - 2$ ) and, finally, the tagged node transmits the third packet in the next slot. This occurs with a probability  $\tilde{\beta}(1 - \tilde{\beta})^{i(x+1)}$ . Hence, the probability of this case is  $\frac{\binom{n-1}{2}\tilde{\beta}^2(1 - \tilde{\beta})^{n-2}}{1 - (1 - \tilde{\beta})^n} \sum_{x=0}^{n-3} \binom{n-3}{x} p_{2,1}^{x+1} (1 - p_{2,1})^{n-3-x} \sum_{i=0}^{\lambda-2} \tilde{\beta}(1 - \tilde{\beta})^{i(x+1)}$ . This simplifies to the first term in the expression for  $\tilde{K}_3(\tilde{\beta})$  in Lemma 2.

*Case 2*: Exactly one among the  $n$  nodes excluding the tagged node transmits the first packet in the renewal interval, say in slot  $t_1$ , with probability  $\frac{(n-1)\tilde{\beta}(1 - \tilde{\beta})^{n-1}}{1 - (1 - \tilde{\beta})^n}$ . Then in slot  $t_1 + i + 1$  another node, excluding the tagged node, transmits the second packet, which occurs with probability  $(n - 2)\tilde{\beta}(1 - \tilde{\beta})^{n-2}(1 - \tilde{\beta})^{i(n-1)}$ , where  $0 \leq i \leq \lambda - 3$ . Thereafter, the tagged node and  $x$  nodes from among the  $n - 3$  other nodes incorrectly estimate the channel occupancy, which occurs with probability  $\binom{n-3}{x} p_{2,1}^{x+1} (1 - p_{2,1})^{n-3-x}$ . No transmissions occur for  $j$  slots ( $0 \leq j \leq \lambda - i - 3$ ), and in slot  $t_1 + i + 1 + j + 1$ , the tagged node transmits the third packet, which occurs with probability  $\tilde{\beta}(1 - \tilde{\beta})^{j(x+1)}$ . Summing over all the possible values of  $i, j$ , and  $x$  yields the second term in the expression for  $\tilde{K}_2(\tilde{\beta})$  in Lemma 2.

The expression for  $\tilde{\alpha}_i$  in terms of  $\tilde{K}_i(\tilde{\beta})$  in (10) follows from Baye's rule.

### E. Proof of Theorem 3

The expression for  $\tilde{\gamma}$  follows directly from the law of total probability. Also, if a tagged node erroneously transmits when already there are two ongoing transmissions in the channel, then a collision is inevitable.<sup>5</sup> Hence,  $\tilde{P}_3(\tilde{\beta}) = 1$ .

*Expression for  $\tilde{P}_1(\tilde{\beta})$* : Let the packet transmitted by the tagged node be the first packet in a renewal interval. The events that contribute to the expression for  $\tilde{P}_1(\tilde{\beta})$  are the same as those that contribute to  $P_1(\cdot)$  in Appendix B except that the following additional event can occur due to incorrect estimation: None of the remaining  $n - 1$  nodes transmit during the first  $i$  slots ( $0 \leq i \leq \lambda - 1$ ) of the packet transmitted by

<sup>5</sup>This is because, as mentioned, we ignore the unlikely event where the tagged node's transmission erroneously commences after the number of ongoing transmissions has decreased from two to one.



the tagged node, which occurs with probability  $(1 - \tilde{\beta})^{i(n-1)}$ . Then, in slot  $i + 1$ , exactly one among the  $n - 1$  nodes transmits, which occurs with a probability  $(n - 1)\tilde{\beta}(1 - \tilde{\beta})^{n-2}$ . Finally, in the remaining  $\lambda - i - 1$  slots of the first packet, at least one of the remaining  $n - 2$  nodes erroneously transmits, which occurs with probability  $1 - \Theta^{n-2}(\lambda - i - 1)$ . Hence, the probability of this additional collision event is  $(1 - \tilde{\beta})^{i(n-1)}(n - 1)\tilde{\beta}(1 - \tilde{\beta})^{n-2}(1 - \Theta^{n-2}(\lambda - i - 1))$ . Summing it over  $i$  and adding it to the expression for  $P_1(\tilde{\beta})$  yields the expression in (13).

*Expression for  $\tilde{P}_2(\tilde{\beta})$ :* The collision event that contributes to the expression for  $P_2(\cdot)$  in Appendix B also contributes to the expression for  $\tilde{P}_2(\tilde{\beta})$ . Incorrect estimation can lead to the following additional event, in which the tagged node transmits the second packet in a renewal interval and a collision occurs subsequently due to a third transmission. Say the tagged node transmits in the  $(i + 2)$ <sup>th</sup> slot ( $0 \leq i \leq \lambda - 2$ ) of the first packet transmitted by one node among the other  $n - 1$  nodes. Given that the tagged node has transmitted the second packet, the probability of this event is  $\frac{(n-1)\tilde{\beta}(1-\tilde{\beta})^{n-1}(1-\tilde{\beta})^{i(n-1)}\tilde{\beta}(1-\tilde{\beta})^{n-2}}{(1-(1-\tilde{\beta})^n)K_2(\tilde{\beta})}$ . In the remaining  $\lambda - i - 2$  slots of the first packet, at least one of the remaining  $n - 2$  nodes erroneously transmits a third packet to cause the collision, which occurs with probability  $1 - \left(p_{2,1}(1 - \tilde{\beta})^{\lambda-i-2} + 1 - p_{2,1}\right)^{n-2} = 1 - \Theta^{n-2}(\lambda - i - 2)$ . Summing the probabilities over  $i$  and adding them to  $P_2(\tilde{\beta})$  yields (14).

## REFERENCES

- [1] IEEE 802.11 Working Group, <http://www.ieee802.org/11/index.shtml>.
- [2] L. Tong, Q. Zhao, and G. Mergen, "Multipacket reception in random access wireless networks: From signal processing to optimal medium access control," *IEEE Commun. Mag.*, vol. 39, pp. 108–112, Nov. 2001.
- [3] J. A. Stine, "Exploiting smart antennas in wireless mesh networks using contention access," *IEEE Trans. Wireless Commun.*, vol. 13, pp. 38–49, Apr. 2006.
- [4] F. Shad, T. D. Todd, V. Kezys, and J. Litva, "Dynamic slot allocation (DSA) in indoor SDMA/TDMA using a smart antenna basestation," *IEEE/ACM Trans. Networking*, vol. 9, pp. 69–81, Feb. 2001.
- [5] Q. Zhao and L. Tong, "A multiqueue service room MAC protocol for wireless networks with multipacket reception," *IEEE/ACM Trans. Networking*, vol. 11, pp. 125–137, Feb. 2003.
- [6] W. L. Huang, K. B. Letaief, and Y. J. Zhang, "Joint channel state based random access and adaptive modulation in wireless LANs with multipacket reception," *IEEE Trans. Wireless Commun.*, vol. 7, pp. 4185–4197, Nov. 2008.
- [7] L. Tong, V. Naware, and P. Venkatasubramanian, "Signal processing in random access," *IEEE Signal Proc. Mag.*, vol. 21, pp. 29–39, Sep. 2004.
- [8] S. Ghez, S. Verdu, and S. C. Schwartz, "Stability properties of slotted ALOHA with multipacket reception capability," *IEEE Trans. Automat. Contr.*, vol. 33, pp. 640–649, Jul. 1988.
- [9] S. Ghez, S. Verdu, and S. C. Schwartz, "Optimal decentralized control in the random-access multipacket channel," *IEEE Trans. Automat. Contr.*, vol. 34, pp. 1153–1163, Nov. 1989.
- [10] V. Naware, G. Mergen, and L. Tong, "Stability and delay of finite user slotted ALOHA with multipacket reception," *IEEE Trans. Inform. Theory*, vol. 51, pp. 2636–2656, Jul. 2005.
- [11] Q. Zhao and L. Tong, "A dynamic queue protocol for multiaccess wireless networks with multipacket reception," *IEEE Trans. Wireless Commun.*, vol. 3, pp. 2221–2231, Jun. 2004.
- [12] D. S. Chan and T. Berger, "Performance and cross-layer design of CSMA for wireless networks with multipacket reception," in *Proc. IEEE Asilomar Conf. Signals, Syst., Computers (ACSSC)*, vol. 2, pp. 1917–1921, Nov. 2004.
- [13] R. H. Gau, "Modeling the slotted nonpersistent CSMA protocol for wireless access networks with multiple packet reception," *IEEE Commun. Lett.*, vol. 13, pp. 797–799, Oct. 2009.
- [14] P. X. Zheng, Y. J. Zhang, and S. C. Liew, "Multipacket reception in wireless local area networks," in *Proc. ICC*, pp. 3670–3675, Jun. 2006.
- [15] S. Barghi, H. Jafarkhani, and H. Yosefi-zadeh, "MIMO-assisted MPR-aware MAC design for asynchronous WLANs," *IEEE/ACM Trans. Networking*, vol. 19, pp. 1652–1665, Dec. 2011.
- [16] F. Babich and M. Comisso, "Theoretical analysis of asynchronous multipacket reception in 802.11 networks," *IEEE Trans. Commun.*, vol. 58, pp. 1782–1794, Jun. 2010.
- [17] F. Babich, M. Comisso, and A. Dorni, "Multi-packet communication in 802.11 networks: A MAC/PHY backward compatible solution," in *Proc. Globecom*, pp. 1–5, Dec. 2011.
- [18] G. Bianchi, "Performance analysis of the IEEE 802.11 distributed coordination function," *IEEE J. Sel. Areas Commun.*, vol. 18, pp. 535–547, Mar. 2000.
- [19] A. Kumar, E. Altman, D. Miorandi, and M. Goyal, "New insights from a fixed point analysis of single cell IEEE 802.11 WLANs," *IEEE/ACM Trans. Networking*, vol. 15, pp. 588–601, Jun. 2007.
- [20] A. Kumar and D. Patil, "Stability and throughput analysis of unslotted CDMA-ALOHA with finite number of users and code sharing," *Telecommun. Syst.*, vol. 8, pp. 257–275, 1997.
- [21] T. Issariyakul, D. Niyato, E. Hossain, and A. S. Alfa, "Exact distribution of access delay in IEEE 802.11 DCF MAC," in *Proc. Globecom*, pp. 25–38, Dec. 2005.
- [22] M. M. Carvalho and J. J. Garcia-Luna-Aceves, "Delay analysis of IEEE 802.11 in single-hop networks," in *Proc. IEEE Intl. Conf. Network Protocols*, pp. 146–155, Nov. 2003.
- [23] M. Jiang and L. Hanzo, "Multiuser MIMO-OFDM for next-generation wireless systems," *Proc. IEEE*, vol. 95, pp. 1430–1469, Jul. 2007.
- [24] C. Budianu and L. Tong, "Channel estimation under asynchronous packet interference," *IEEE Trans. Signal Process.*, vol. 53, pp. 333–345, Jan. 2005.
- [25] R. W. Wolff, *Stochastic Modeling and the Theory of Queues*. Prentice Hall, 1989.
- [26] M. A. Khamisi and W. A. Kirk, *An Introduction to Metric Spaces and Fixed Point Theory*. John Wiley, 2001.
- [27] L. C. Godara, "Application of antenna arrays to mobile communications—part II: Beam forming and direction-of-arrival considerations," *Proc. IEEE*, vol. 85, pp. 1193–1245, Aug. 1997.
- [28] T. Kaiser, "When will smart antennas be ready for the market? Part I," *IEEE Sig. Proc. Mag.*, vol. 22, pp. 87–92, Mar. 2005.
- [29] M. Z. Siam and M. Krunz, "An overview of MIMO-oriented channel access in wireless networks," *IEEE Wireless Commun.*, vol. 15, pp. 63–69, Feb. 2008.
- [30] D. N. Lawley, "Tests of significance of the latent roots of the covariance and correlation matrices," *Biometrika*, vol. 43, pp. 128–136, Jun. 1956.
- [31] M. Wax and T. Kailath, "Detection of signals by information theoretic criteria," *IEEE Trans. Acoust., Speech, Signal Process.*, vol. 33, pp. 387–392, Apr. 1985.
- [32] P. Chen, M. Wicks, and R. Adve, "Development of a procedure for detecting the number of signals in a radar measurement," *IEE Proc. Radar, Sonar Navig.*, vol. 148, pp. 219–226, Aug. 2001.
- [33] M. Benaim and J. Y. L. Boudec, "A class of mean field interaction models for computer and communication systems," *Perform. Eval.*, vol. 20, pp. 243–302, Nov. 2008.

PLACE  
PHOTO  
HERE

**Arpan Mukhopadhyay** has received his Bachelor of Engineering (B.E) degree in Electronics and Telecommunication Eng. from Jadavpur University, Calcutta, India in 2009, and his Master of Engineering (M.E) degree in Telecommunication from Indian Institute of Science, Bangalore in 2011. He is currently pursuing his Ph.D in Electrical and Computer Engineering at the University of Waterloo, Canada. His current areas of research are broadly wireless networking, queueing theory, and optimization algorithms.

PLACE  
PHOTO  
HERE

**Neelesh B. Mehta** (S'98-M'01-SM'06) received his Bachelor of Technology degree in Electronics and Communications Eng. from the Indian Institute of Technology (IIT), Madras in 1996, and his M.S. and Ph.D. degrees in Electrical Eng. from the California Institute of Technology, Pasadena, CA, USA in 1997 and 2001, respectively. He is now an Associate Professor in the Dept. of Electrical Communication Eng. at the Indian Institute of Science (IISc), Bangalore, India. Prior to joining IISc in 2007, he was a research scientist in AT&T Laboratories, NJ, USA, Broadcom Corp., NJ, USA, and Mitsubishi Electric Research Laboratories (MERL), MA, USA from 2001 to 2007.

His research includes work on link adaptation, multiple access protocols, cellular system design, MIMO and antenna selection, cooperative communications, energy harvesting networks, and cognitive radio. He was also actively involved in the Radio Access Network (RAN1) standardization activities in 3GPP from 2003 to 2007. He was a TPC co-chair for tracks/symposia in ICC 2013, WISARD 2010 & 2011, NCC 2011, VTC 2009 (Fall), and Chinacom 2008. He has co-authored 35 IEEE transactions papers, 60+ conference papers, and three book chapters, and is a co-inventor in 20 issued US patents. He is an Editor of IEEE Wireless Communications Letters and the Journal for Communications and Networks, and currently serves as the Director of Conference Publications in the Board of Governors of the IEEE Communications Society.

PLACE  
PHOTO  
HERE

**Vikram Srinivasan** has been at Alcatel-Lucent Bell Labs since 2007. Prior to joining Bell Labs, he was an Assistant Professor at the National University of Singapore from 2003-2007. He received his PhD from the University of California at San Diego in 2003 and M.E. in Electrical Communications Engineering from the Indian Institute of Science in 1998. His research interests are broadly in the area of wireless networking and mobile computing. He is an associate editor of the IEEE Transactions on Mobile Computing.