

P02-23 ID248

THE DYNAMICAL ANALYSIS OF TABLE TENNIS FOREHAND AND BACKHAND DRIVES

Hsin-Hsueh Huang¹, Yi-Chang Hsueh², Yu-Yuen Chen², Ting-Jui Chang²,
Kuang-Min Pan², Kuei-Shu Huang³, Chien-Lu Tsai²

¹P.E. Section, Songshan High School of Agriculture and Industry, Taipei

²Department of P.E., National Taiwan Normal University, Taipei, Taiwan

³Office of P.E., Tamkang University, New Taipei City, Taiwan

The purpose of this study was to analyze the dynamics parameters of table tennis drives by Taiwan collegiate first class table tennis players when they were performing straight and cross court forehand and backhand drives from receiving topspin and backspin serves. Ten Vicon MX-13⁺ high-speed cameras (250Hz) and two Kistler force plates (1500 Hz) were used to collect the kinematics and kinetics data. The Wilcoxon matched-pairs signed-rank nonparametric statistical test was to compare the differences between forehand and backhand drives. The results showed that there were significant differences between forehand and backhand drives were in the ball initial velocity and the kinetics variables. The GRF data of the players were different between forehand and backhand drives when they performed four different paths of drive.

KEY WORDS: biomechanics, topspin, backspin, cross.

INTRODUCTION: The forehand and the backhand drives are two major attack techniques in the table tennis game. The modern table tennis players should improve not only the forehand but also the backhand drive techniques in the competition. Most of the previous studies were focused on the forehand drive performance. Such as Neal (1991) found Chinese elite players were able to hit the ball at a higher initial velocity compared with their Australian counterparts, while Yoshida, Sugiyama & Murakoshi (2004) found that the duration time from the ball rebound on the table to the contact of the forehand drives was about 0.2 seconds. Tsai, Pan, Huang, Chang, Hsueh, Wang & Chang (2010) reported the tactics of the table tennis players to perform the forehand drive in receiving backspin would increase the racket tilt angle in advance and increase the upswing path angle. Chen, Hsueh & Tsai (2012) described the players performed a greater lateral impulse to cause the trunk rotation and decelerated their body from initial to mid-phase and then accelerated the body to perform a forehand drive shot. The biomechanical differences between the forehand and the backhand drives are not clear. Only a few studies such as Chen, Hsueh & Tsai (2012) aimed on the analysis of the Ground Reaction Force (GRF) of the forehand drive. The purposes of this study were to compare the kinematics and the GRF parameters of Taiwanese table tennis players when they were performing the forehand and backhand drives in different variations.

METHODS: Six collegiate male elite table tennis players in Taiwan served as the participants. All of the participants are right handed. In figure 1, the players stood on two force plates separately at one end of the table to return the serves. The server served the topspin and the backspin shots into the circles (50cm diameter) on the participants end side. The participants returned forehand and backhand drives in straight and diagonal paths into the 50x50cm squares on serve end in random order. The players returned the serves and hit the ball either straight forward or on the diagonal direction. The landing area was the 50x50cm square at right and left of the server's end. A Vicon Motion Capture system with 10 cameras (Vicon, Oxford, U.K., 250 Hz) and the Vicon Nexus 1.52 software were used to record and analyze the 3D kinematics data of the reflection balls. Two Kistler force plates (Kistler, Winterthur, Switzerland, 1500 Hz) were used to collect right and left foot kinetics data. We divided the drive movement into the downward swing, upward swing and the contact point phases. The selected kinematics (initial velocity of ball) and kinetics variables (the peak GRF & GRF at the

contact point) between forehand and backhand movements were tested by Wilcoxon matched-paired signed rank nonparametric statistical test. All the variables were tested by SPSS 19.0 statistical software at a .05 significant level.

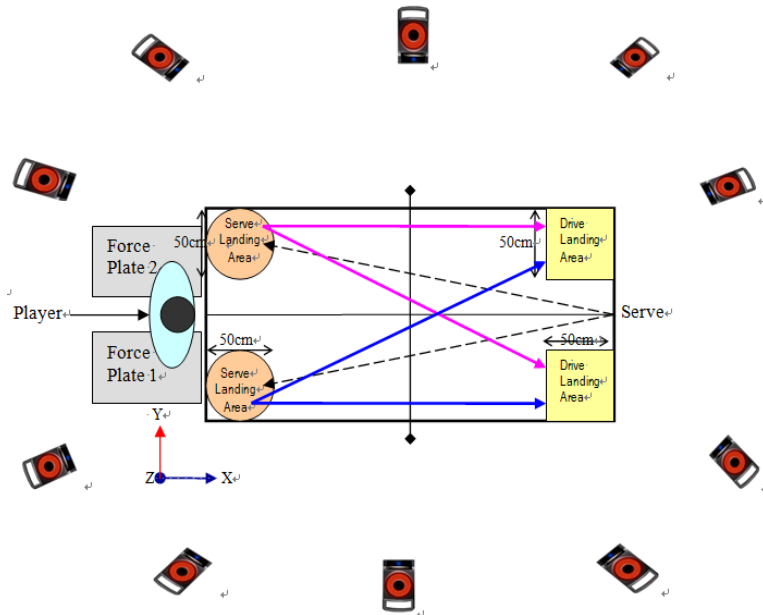

Figure 1 · The schematic experimental setup

RESULTS: Figure 2 (Fx, saggital) and figure 3 (Fz, vertical) show the Ground Reaction Force (GRF) patterns of right and left foot of one participant's forehand and backhand drives.

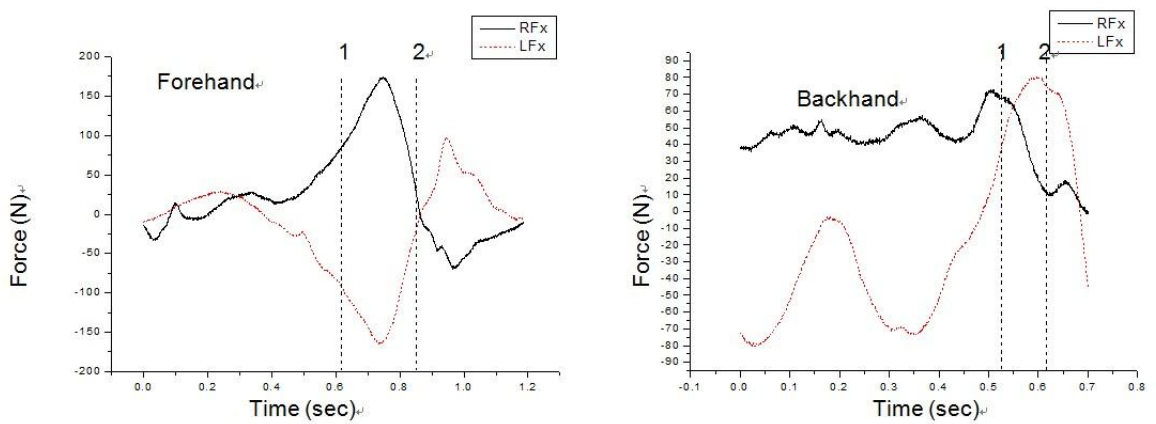

Figure 2 · The ground reaction force of two feet of forehand and backhand drives in Fx

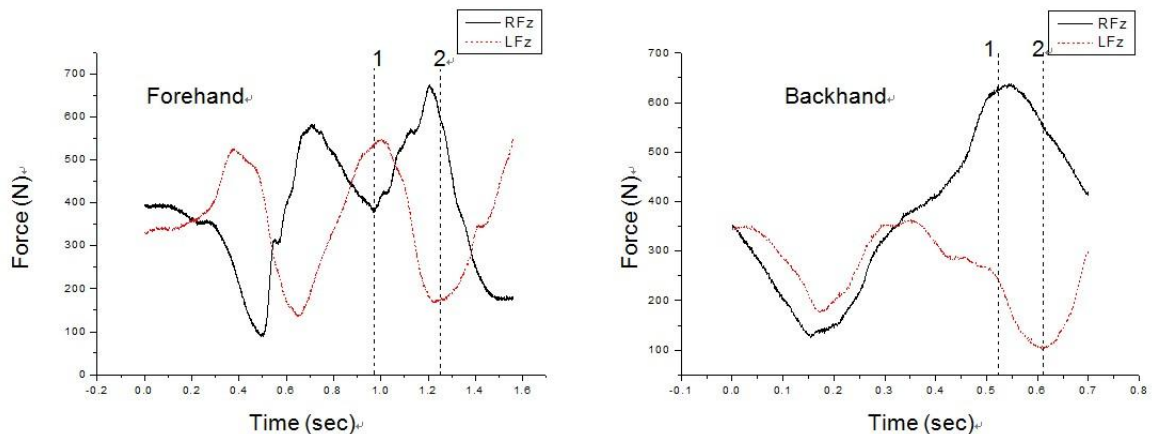

Figure 3 · The ground reaction force of two feet of forehand and backhand drives in Fz

In the figure 2 and 3, the end of the racket downward movement was shown as the line 1 and the contact point was as the line 2, the upward swing movement is between the line 1 and the line 2. Table 1 shows the ball initial velocities of the forehand and backhand drives in straight and cross court paths. And the ground reaction force (GRF) at the contact point and the peak force during the movements of the forehand and backhand drives were shown as in the table 1.

Table 1
The Kinetics Variables Comparison Between the Forehand and the Backhand Drives

Techniques Variables	Serve Spins & Drive Paths		Forehand Drive	Backhand Drive	<i>P</i>
Ball Initial Velocity (m/s)	Topspin	Straight Line	17.91 ± 1.61	13.55 ± 1.79	*
	Topspin	Diagonal Line	18.71 ± 1.24	15.24 ± 0.77	*
	Underspin	Straight Line	15.86 ± 2.03	14.20 ± 1.20	
	Underspin	Diagonal Line	17.43 ± 1.06	14.29 ± 0.82	*
Right Foot Contact Fx (Bw%)	Topspin	Straight Line	0.93±5.00	-5.77±4.98	
	Topspin	Diagonal Line	1.75±3.04	-3.78±5.66	
	Underspin	Straight Line	-3.70±7.93	-8.84±3.61	
	Underspin	Diagonal Line	-3.29±6.88	-6.74±4.60	
Left Foot Contact Fx (Bw%)	Topspin	Straight Line	-3.73±8.13	5.96±5.23	*
	Topspin	Diagonal Line	-2.36±5.28	7.03±4.45	*
	Underspin	Straight Line	-1.70±8.35	7.36±7.26	
	Underspin	Diagonal Line	0.00±2.71	8.54±7.24	*
Right Foot Contact Fz (Bw%)	Topspin	Straight Line	35.59±19.09	66.80±21.12	
	Topspin	Diagonal Line	35.40±16.72	71.03±29.68	*
	Underspin	Straight Line	54.18±25.70	65.16±18.14	
	Underspin	Diagonal Line	63.46±39.88	60.79±19.14	
Left Foot Contact Fz (Bw%)	Topspin	Straight Line	35.74±30.03	38.82±19.21	
	Topspin	Diagonal Line	17.38±27.54	39.17±29.98	
	Underspin	Straight Line	29.62±30.31	40.91±30.94	
	Underspin	Diagonal Line	13.88±30.91	40.32±16.59	*
Right Foot Peak Fx (Bw%)	Topspin	Straight Line	30.23±6.48	-1.34±4.88	*
	Topspin	Diagonal Line	31.31±10.90	2.22±6.51	*
	Backspin	Straight Line	27.76±5.82	-0.36±4.25	*
	Backspin	Diagonal Line	31.99±6.79	4.03±7.25	*
Left Foot Peak Fx (Bw%)	Topspin	Straight Line	-3.84±8.17	12.72±4.39	*
	Topspin	Diagonal Line	-2.42±5.45	15.03±4.58	*
	Backspin	Straight Line	-1.78±8.33	19.45±6.39	*
	Backspin	Diagonal Line	0.01±2.99	21.84±6.52	*
Right Foot Peak Fz (Bw%)	Topspin	Straight Line	99.03±35.38	78.31±16.78	
	Topspin	Diagonal Line	98.20±22.49	83.61±19.66	
	Backspin	Straight Line	110.12±18.02	78.62±15.22	*
	Backspin	Diagonal Line	121.01±11.65	78.51±17.82	*
Left Foot Peak Fz (Bw%)	Topspin	Straight Line	66.45±18.42	61.78±23.78	
	Topspin	Diagonal Line	65.95±21.37	62.20±26.30	
	Backspin	Straight Line	69.95±28.69	61.86±28.43	*
	Backspin	Diagonal Line	62.09±25.19	62.14±19.00	

**p* < .05

DISCUSSION: From figure 2 and 3, we found that the peak GRF of the forehand and the backhand drives were happening before the contact point both on the right and the left foot.

Table 1 showed that the ball initial velocities of the forehand and backhand drives in straight and cross court paths. We found the ball initial velocities of the forehand drives are faster than the backhand drives except the straight drive from return the backspin. The saggital (Fx) and vertical direction (Fz) GRF of the participants at the contact point showed in the table 1. We found the participants exerted the minor Fx both on the right and left foot. The right foot exerted backward Fx to return the backspin serves both in the forehand and backhand drives. There were significant difference between the forehand and backhand drives in receiving topspin serves in Fx on the left foot. The peak forces during the entire driving movements were shown as in the table 1. The right foot peak Fx of the forehand drives was significant greater than the backhand drive. The peak Fx of left foot in the backhand drive was significant greater than in the forehand drive. The peak vertical GRF of the forehand drives were around 100% Body Weight (BW) in return topspin serves and above one BW in return backspin serve on the right foot. This might manifest the results of the study Tsai, et al (2010), the tactics of the table tennis players to perform the forehand drive in receiving backspin would increase the upswing path angle was coming from the vertical force generated by the right foot of the participants. The right foot peak Fz in backhand drives were around 80% BW. Both of the forehand and backhand drive peak vertical GRF were less 70% BW on two feet of the participants. The left foot was producing the brake force during the forehand drive since right foot was the dominate foot in the backhand drive. The right foot exerted greater peak Fz during the forehand drive movement in receiving backspin serves than in the backhand drive.

CONCLUSION: In this study, we were interested in analyzing the 3D table tennis ball image and the kinetics parameters of different table tennis drive paths when the players returned either topspin or backspin serves in the forehand and the backhand drives. The results of this study showed that the peak force of each movement appeared just before the contact point. The GRF value in x-axis direction was small. The vertical GRF value was the greater than the saggital force. We found that the kinetics GRF data of the players were different between forehand and backhand drives when they performed down the line and the cross court drives while receiving the topspin and backspin serves from the opponents. The players exerted the greater right foot GRF in receiving backspin than receiving topspin serves. The table tennis players performed the different kinetics strategies between the forehand and backhand drive movements. In the forehand movement, the left foot was to brake and balance the force that the right foot exerted. However that the both of right foot and left foot exerted the forward Fx to perform the backhand drives.

REFERENCES:

- Chen, Y.-Y., Hsueh, Y.-C. & Tsai, C.-L. (2012). Switching the horizontal GRF to the path of progression in the table tennis forehand drive. *Proceedings of 30th Conference of the International Society of Biomechanics in Sports 2012*, Melbourne, Australia.
- Neal, R. L. (1991). The mechanics of the forehand loop and drive shots in table tennis. *The Australian Journal of Science and Medicine in Sport*, 23(1), 3-11.
- Tsai, C.-T., Pan, K.-M., Huang, K.-S., Chang, T.-J., Hsueh, Y.-C., Wang, L.-M., & Chang, S.-S. (2010). The surface EMG activity of the upper limb muscles in table tennis forehand drives. *Proceedings of XXVIII International Symposium on Biomechanics in Sports 2010*, (pp305-308), Marquette, Michigan, USA.
- Yoshida, K., Sugiyama, K., & Murakoshi, S. (2004). The technique used to receive a rotating ball in table tennis. *Science and Racket, III*, 116-120.

Acknowledgement

The authors like to express our appreciation to the financial support by National Science Council, "Aim for the Top University Plan" of the National Taiwan Normal University and the Ministry of Education, Taiwan, R.O.C.. We also want to thank the participants and the helps and efforts from the colleagues and the graduated students of the Sports Biomechanics Lab in National Taiwan Normal University.