

## Design and Implement of Multi-Antennas for High Data Rate Communication

Hsien-Wei Tseng<sup>1,a</sup>, Yang-Han Lee<sup>2</sup>, Yung-Wen Lee<sup>2</sup>, Chih-Yuan Lo<sup>2</sup>,  
Yih-Guang Jan<sup>2</sup>, and Ming-Hsueh Chuang<sup>3</sup>

<sup>1</sup>Department of Computer and Communication Engineering De Lin Institute of Technology,  
Tucheng, New Taipei City, Taiwan, 23656, R.O.C.

<sup>2</sup>Department of Electrical Engineering Tamkang University, Tamsui, New Taipei city, Taiwan, 25137,  
R.O.C.

<sup>3</sup>Department of Electrical Engineering National Taiwan University of Science and Technology, Taipei  
city, Taiwan, 106, R.O.C.

<sup>a</sup>hsienwei.tseng@gmail.com

**Keywords:** Multi-Antennas, Multi-input Multi-output (MIMO), IEEE 802.11n

**Abstract.** In this paper, it tries from experimental measurements to derive the required minimum antenna isolation and from using this minimum antenna isolation to have the MIMO to execute at its utmost efficiency. The issue of the minimum antenna isolation is actually the problem of pursuing the possible antenna module area of a multi-antenna system. As smaller size communication system is explored in real life the request of small size communication system has been discussed and many systems have been developed. To verify the feasibility of designing a multi-antenna and high throughput system is through the adopt of many MIMO technique implemented IEEE 802.11n 2x2 products to verify whether its throughput can be doubled. In this paper we integrate 4 2x2 AP antenna sets and under the operation of 8 antennas to attain the 1200 Mbps PHY rate through proper selection and design of available antennas, for 1200 Mbps PHY rate it is equivalently to have more than 600 Mbps throughput and with this implementation it is enable to prove the feasibility of the designed system.

### Introduction

With multi-input, multi-output (MIMO) technique it provides a prevailing throughput rate in the wireless area network (WLAN). The MIMO technique is introduced in 1995 and its system size was so voluminous that it was unable to effectively integrate the circuits together. It is until when the high speed Fourier transform is introduced so as to simplify the circuit layout and make large scale chip area reduction and to make the availability of chip application and development. With MIMO technique it will greatly improve the transmission range and capacity, the MIMO is the standard specifications in IEEE 802.11n draft 2.0.

As shown in Figure 1, MIMO architecture is to simultaneously transmit many signals in the same frequency band by utilizing many sets of antennas; it also uses multiple-antennas to simultaneously receive signals at the receiver terminal. In the transmitter side it transmits many data streams and through antennas propagation to arrive at receiving antenna terminals. In the antennas propagation different transmitting signals will pass through different transmitting paths to arrive the receiving terminals. These transmitting paths are termed spatial functions and the spatial functions are expressed in matrix form. By solving this matrix it can find the solutions of these spatial functions and consequently through signals analyzing and combinations at every receiver antenna terminals the original transmitted data stream can be recovered. In this manner under the constraint of finite available bandwidth multiple signals can be transmitted to improve bandwidth utilization rate. Among various bandwidth utilization improvement techniques the MIMO technique has the highest bandwidth utilization rate.

In wireless communication system the feasibility of high data rate is proved by utilizing MIMO technique, its reliable data rate for each antenna transmission path is 150 Mbps PHY rate and it needs to have at least 7 antennas to reach the PHY rate of 1 Gbps.

In the current 2x2 MIMO system, 2 transmitting antennas and 2 receiving antennas, it needs to maintain good antenna isolation or polarization in order to attain good system throughput. By either utilizing different antenna polarization or changing antenna distance it can affect their relative isolations [1]; the best antenna arrangement is to have two antennas orthogonal to each other [2][3]. In this paper it has the goal of using 7 ~8 antennas to attain 1 Gbps data rate [4-6]. The determination of the minimum antenna isolation to obtain the high data rate is the main topic to be investigated in this paper

This paper is arranged in the following. In Section 2 it simply demonstrates the MIMO communication system. In Section 3 it discusses the design specification and the test method. In Section 4 it proceeds in the system measurement and test to verify the feasible way of attaining high system data rate and to provide the antenna design process. The conclusion and the future work are completed in Section 5.

### The Design of High Data Rate Multi-antenna System

In this paper it is to determine in the high data rate IEEE 802.11n system how many dBs is required in the antenna isolation to attain the maximal rate transmission.

A pair of IEEE 802.11n 2x2 equipments are set up to proceed in the system verification test. The PIFA structured antenna is implemented at the client terminal and this antenna is fixed on the PCB. The antenna position at the AP terminal can be adjusted by changing the antenna set base position, and consequently it can be through adjusting the ‘minimum distance’ between two antennas to attain the maximal data rate and then to determine the antenna isolation. This isolation is defined as the required minimum isolation between two antennas in order to attain the maximal data rate. The effect of antenna on the system data rate is determined from antenna isolation instead of its distance; this is because the antenna distance will be varied when the antenna gain and antenna radiation pattern change and it is therefore more appropriate to use antenna isolation to define the effect of antenna on the system data rate. After the minimum antenna isolation between two antennas has been determined, this isolation value is then inserted into the overall 8 antenna system structure. As shown in Figure 2 is the resulting system structure by connecting 4 sets of IEEE 802.11n apparatus for system verification test, if the total throughput of the four sets of IEEE 802.16n apparatus equals the sum of the throughput of the four individual IEEE 802.16n apparatuses then we can conclude from this verification that the antenna isolation has its required minimum level in order to attain the high data rate.

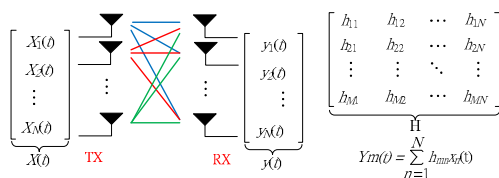

Fig. 1 MIMO Structure and Spatial Function.

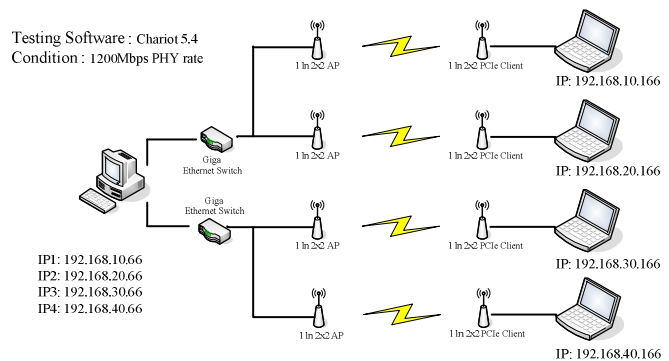

Fig. 2 System Structure of Multi-antenna Measurement System.

**IEEE 802.11n System Parameter.** In IEEE 802.11n when it uses only 1 antenna to transmit data stream its maximal PHY rate is 150 Mbps or 135 Mbps ( $N_{ss}=1$ ). If the selected Guard Interval (GI) is 400 ns the maximal PHY rate can reach 150 Mbps while the maximal PHY rate can reach 135 Mbps when the GI is 800 ns. If it uses 2 antennas to transmit different data streams ( $N_{ss}=2$ ) then the maximum PHY rate will either be 300 Mbps or 270 Mbps. If the GI used is 400 ns then the maximal PHY rate can reach 300 Mbps while the maximal PHY rate will be 270 Mbps when the GI used is 800 ns. Consequently 300 Mbps/270 Mbps/150 Mbps/135 Mbps are having the same modulating parameters; but only in the difference in the selection of the number of spatial streams,  $N_{ss}$ , and the guard interval, GI. This is to demonstrate that when it uses only one Vector Signal Analyzer (VSA) to measure the EVM it can measure only one data stream and consequently it can measure a modulating signal with a maximal rate of 135 Mbps.

**The Measurement of IEEE 802.11n System.** The following items will affect the system throughput measurement

**Transmit Power Level (Transmit Power Level Affects the Effective Transmitting Distance.)**

Depending on the area considered the transmit power level will have different specifications in the allowable maximal power level. Overall it has two standards: Europe ETSI and US FCC. It always adds the antenna gain to get the maximum power level and uses its Equivalent Isotropic Radiated Power (EIRP) as the test standard.  $EIRP \text{ (dBm)} = \text{Transmit power level (dBm)} + \text{Antenna Gain (dB)}$ . When all antennas are active the ETSI restricts the total EIRP of the IEEE 802.11n system should be less than 20 dBm (10 mW) while for US FCC it restricts the total IEEE 802.11n system EIRP should be less than 30 dBm (30 mW). In order to get better transmission performance it restricts the difference of chain's transmitting power be less than  $\pm 1$  dB. This specification will also be depicted in the later measurement. If the transmit power level is too high it will worsen the EVM this is because high transmit power level will saturate the RF power amplifier to make the OFDM signal quality of 64 QAM worse and in order to avoid the happening of this situation the transmit power level per chain in the experiment of all IEEE 802.11n apparatus will be set at 7.5 dBm.

**Transmit EVM (Transmit EVM affects the System Throughput.)** EVM value has great effect on the IEEE 802.11n system throughput; WiFi alliance has the relative constellation error specification for various modulations as shown in Table 1. In this paper it is directly to investigate the antenna effect on the system throughput; it is on purpose to restrict the EVM below -30 dB to prevent the possible effect of non-ideal EVM on the system throughput.

Table 1. Error Vector Magnitude Requirement

Modulation	Coding rate	Relative constellation error (dB)
BPSK	1/2	-5
QPSK	1/2	-10
QPSK	3/4	-13
16-QAM	1/2	-16
16-QAM	3/4	-19
64-QAM	2/3	-22
64-QAM	3/4	-25
64-QAM	5/6	-28

**Transmit Spectrum Mask (Transmit Spectrum Mask Affect the Usage of Neighboring Channel.)** The spectrum mask test needs to meet the specifications of IEEE 802.11n; its purpose is to prevent its interference on neighboring channels. The test system structure and the spectrum specifications are shown respectively in Figures 3 and 4.

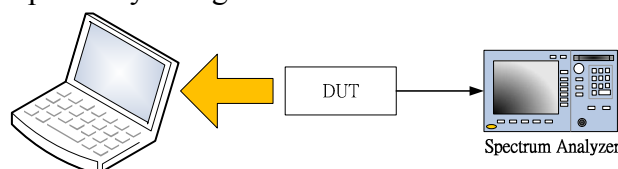

Fig. 3 The Transmit Spectrum Mask Measurement.

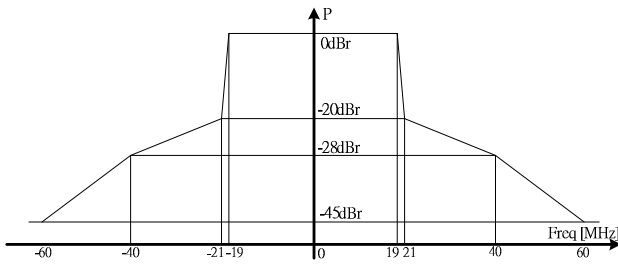

Fig. 4 IEEE 802.11n 40 MHz Spectrum Mask.

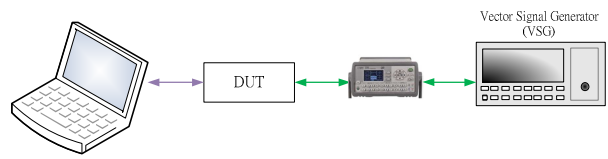

Fig. 5 Receiver Sensitivity Measurement Method.

**Receiver sensitivity (Receiver Sensitivity Affects the Effective Transmission Distance.)** The receiver sensitivity test is to guarantee the important tasks such as to maintain the stability of the receiving signal at the receiver terminal and to make certainty of the transmission distance. The measurement method and the IEEE 802.11n receiver sensitivity requirement are illustrated respectively in Figure 5 and Table 2.

Table 2. Receiver Sensitivity Specifications

Modulation	Rate (R)	Adjacent channel rejection (dB)	Non-adjacent channel rejection (dB)	Minimum sensitivity (dBm) (20MHz channel spacing)	Minimum sensitivity (dBm) (40MHz channel spacing)
BPSK	1/2	16	32	-82	-79
QPSK	1/2	13	29	-79	-76
QPSK	3/4	11	27	-77	-74
16-QAM	1/2	8	24	-74	-71
16-QAM	3/4	4	20	-70	-67
64-QAM	2/3	0	16	-66	-63
64-QAM	3/4	-1	15	-65	-62
64-QAM	5/6	-2	14	-64	-61

**Multi-antenna System Throughput Verification Measurement**

**The Test Environment.** As shown in Figure 6, the system is set up in a perfect ideal indoor environment, it does not find any other AP/Router signal in the sweeping 5 GHz frequency band and no radar signal. The AP antenna arrangement is as shown in Figure 7, the antenna separation of 220 mm that is derived in the previous section has been considered in the arrangement.

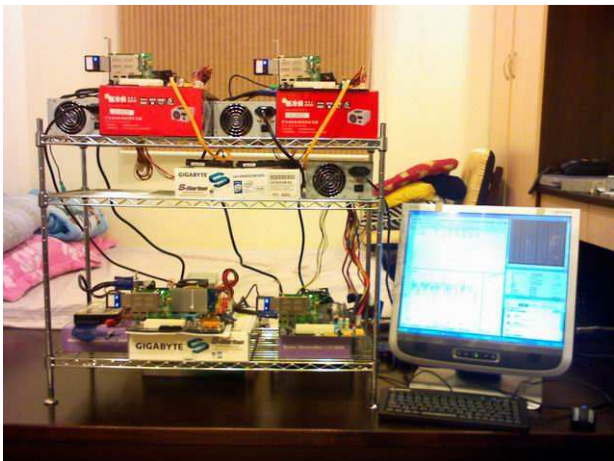

Fig. 6 The Client Card x 4 Set Up.



Fig. 7 The AP Antenna Set Up.

**The Measured Results.** When AP x2 and Client x2 are used in the measurement its measured result is shown in Figure 8 the average throughput is 318 Mbps. When AP x4 and Client x4 are used in the measurement its measured result is shown in Figure 9 the system average throughput is 621 Mbps.

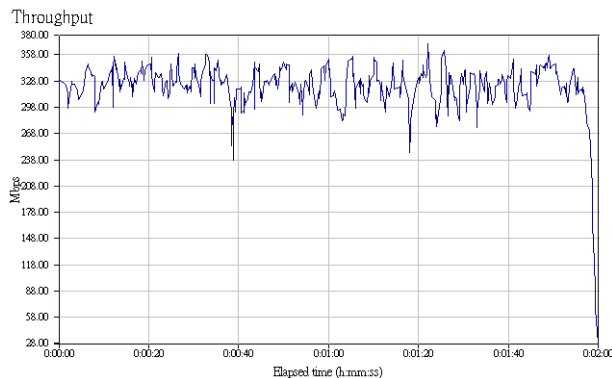

Fig. 8 Measured AP x2 Throughput.

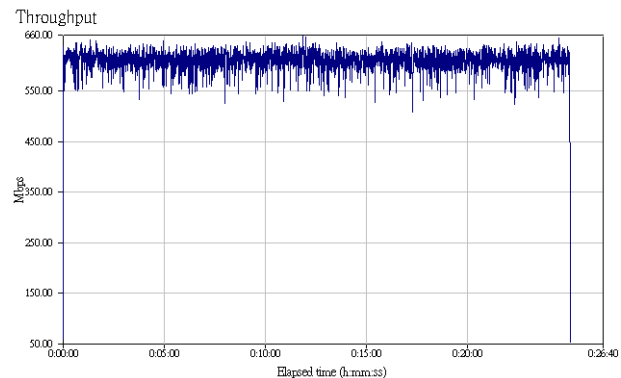

Fig. 9 Measured System Throughput.

**The System Optimization Design and the Determination of System Parameters.** From the experiments performed in this paper it concludes that when the Client Card Antenna is fabricated in the system, its antenna isolation is between -17 dB to -20 dB and the isolation is permitted to have a small variation in various frequency range then from the measurement we can guarantee that when the AP antenna isolation is greater than -37 dB it will obtain 1200 Mbps PHY rate in normal operation and the system throughput greater reaches 631 Mbps.

## Conclusion

When the Client Card antenna has isolation of -17 dB ~ -20 dB, and the AP antenna isolation needs to have isolation greater than -37 dB to enable the 802.11n system throughput to reach its optimized state. If we can increase the Client Card antenna isolation then it is possible to lower the AP antenna isolation that we can further reduce the AP multi-antenna fabrication area. This is our future study task. The volume of Client Card has been greatly miniaturized and therefore its isolation is not ideal but we can reach the strict throughput requirement by the design of AP antennas and therefore the same consideration can be applied in the future design of WiMAX base station.

## Acknowledgments

This study was support from the National Science Council, ROC under contracts NSC 100-2219-E-009 -027 and NSC 100-2221-E-032-031.

## References

- [1] K. Chung and J.H.Yoon, *Integrated MIMO antenna with high isolation characteristic*, Electronics Letters, vol. 43, (2007) pp. 199-201.
- [2] X. P. Yang, Chen Qiang, and K.Sawaya, *Effect of Antenna Locations on Indoor MIMO System*, Antennas and Wireless Propagation Letters, vol. 6, (2007) pp. 165-167.
- [3] Q. Zhou and H. Dai, *Joint antenna selection and link adaptation for MIMO systems*, Vehicular Technology, vol. 55, (2005) pp. 243-255.
- [4] X. Zhang, L. Zhaobiao and W. Wenbo, *Performance Analysis of Multiuser Diversity in MIMO Systems with Antenna Selection*, Wireless Communications, vol. 7, (2008) pp. 15-21.
- [5] M. Sadek, A. Tarighat, and A.H. Sayed, *Active Antenna Selection in Multiuser MIMO Communications*, Signal Processing, Vol. 55, (2006) pp. 1498-1510.
- [6] D. W. Browne, M. Manteghi, M. P. Fitz, and R. S. Yahya, *Experiments With Compact Antenna Arrays for MIMO Radio Communications*, Antennas and Propagation, vol. 54, (2006) pp. 3239-3250.