

The Development and Applications of the Remote Real-Time Video Surveillance System

Wei Chen¹, Chien-Chou Shih^{2*} and Lain-Jinn Hwang³

¹*Department of Information and Multimedia Application, Asia University, Taichung, Taiwan 413, R.O.C.*

²*Department of Information and Communication, Tamkang University, Tamsui, Taiwan 251, R.O.C.*

³*Department of Computer Science and Information Engineering, Tamkang University, Tamsui, Taiwan 251, R.O.C.*

Abstract

In the efforts to fight crimes and terrorism, governments install video surveillance equipment that works like thousands of eyes in airports, ports, major roadways, government buildings, and important facilities. However, such kinds of surveillance system were hardware dependence and high budget for the installation. This paper is addressed to the development of the web-based real-time video surveillance framework. The proposed real-time many-to-many surveillance system can provide users to dynamically plug in their digital photographic equipments, such as web camera and CCTV (digital video) through the Internet without the installation of extra software. The constructed system also achieves an adjustable motion detection facility which can trigger the video recording and the real-time e-mail notification via PC or 3G mobile message.

Key Words: Web Camera, Video Server, Motion Detection, Video Surveillance

1. Background

In light of the worsening crime situation and the threat of terrorism, all kinds of monitors are being set up on street corners, stores, warehouses, airports, military facilities, and even research institutions and schools to prevent burglary, vandalism and terrorist attack. Some of the surveillance systems are manned, but most are not. The majority of surveillance systems serve as an intimidation and after-the-fact replay tools while being unable to stop the crime on the spot. It is akin to having thousands of eyes watching but without a brain to process the information and make judgment. The real-time viewing and alert of a surveillance system rely on security personnel on-duty to watch the monitors at all time and promptly respond to emergency situation. Because of this major drawback (Figure 1), surveillance system

typically faces the following constraints:

- The surveillance personnel are put to the task of watching multiple screens for a long period of time that they are prone to lose concentration and miss the right timing to make a decision.



Figure 1. Conventional security surveillance control system [1].

*Corresponding author. E-mail: ccs@mail.tku.edu.tw

- The surveillance personnel must watch the monitors at a fixed spot at all time and are unable to perform remote, multi-point surveillance as confined by the physical layout and spatial distance.
- Even stand alone or computer-based, the conventional surveillance system records the images directly in specific video format and it is unable to categorize and manage the graphic information, which makes subsequent retrieval and tracking difficult.
- Conventional surveillance system records the images directly and is unable to categorize and manage the graphic information, which makes subsequent retrieval and tracking difficult.
- Due to the considerable manpower, the conventional surveillance systems incur higher costs and are subject to human errors.
- The installation of conventional non-networked surveillance system is hardware dependence. The connected video cameras are confined by fixed location and distance that requires the setup of a control room and is unable to perform mobile many-to-many surveillance.

In order to address the above drawbacks of the conventional surveillance system, this paper is devoted to develop a many-to-many real-time video surveillance platform based on Flash Media Server technologies. The major contribution of the proposed system is to achieve a hardware-independent and easy to install real-time surveillance system. The user can plug in the web cameras and IP cameras at any time and any place through the web site without any extra software installation. Moreover, each connected web camera has an adjustable motion detecting interface for the detection of invasion or changes at critical scenes and the proposed surveillance server can perform video reporting via e-mail, send short message, issue alarm, or send the video directly to 3G mobile phone, and simultaneously record the audio and video images at the scene and respond promptly.

The remainder of the paper is presented in five parts: Section 2 is the discussion of streaming media and video server techniques; section 3 is the configuration of remote video surveillance system; section 4 is the system construction; section 5 is the comparison and testing of systems; and section 6 is conclusion and future work.

2. Discussion of Streaming Media and Video Server Techniques

The rapid advancement of optical and digital technologies in recent years have made many digital and optical equipment, such as web camera, digital camera (DC), and digital video (DV) widely affordable to professionals and consumers alike, and the applications of those equipment are expanding. Thus how to make effective and multifarious use of digital photographic equipment has become a topic of interest to the public. Made possible by the rapid innovation of optoelectronic process technology, today's web camera is small in size and easy to install, offers good resolution, and costs less. It has become an indispensable tool for real-time communications (RTC), video conference, and distance video learning. But in the early days, the transmission of audio and video signals over the Internet was plagued by poor picture quality and frame delay due to the lack of sufficient bandwidth. Nowadays with expanded bandwidth, improved streaming media technology and compression technology, the quality of audio and video data transmitted over the Internet is greatly enhanced.

Streaming media refers to Internet transmission of multimedia content using streaming technique. It entails the transfer of time-based media, such as voice and video, from server-side to client-side computer in a real-time or on-demand manner where users need not wait for the download of the entire file or just wait for a few seconds or dozens of seconds to view the file after receiving sufficient stream data. Such algorithm differs from conventional Internet transmission. Streaming media requires the processing of specific video server in order for users to play the multimedia content; and the client-side will not save any copy of the multimedia content at the time of receiving or going offline. Such multimedia transfer features the use of variable bandwidth technique and transmission of digital multimedia in stream.

The methods for streaming transmission include real-time streaming and progressive streaming. Real-time streaming achieves the purpose of real-time broadcast of audio/video signals through video server codec and the use of some communication protocols. Progressive streaming achieves the purpose of audio/video broadcast in a sequential manner through HTTP protocol

[2,3]. Many companies have embarked on the research and development of software and hardware for real-time streaming. Better known systems include Microsoft Windows Media Series 9 [2], RealNetworks RealSystem 10 [4], Apple QuickTime 6.0 [5], and Macromedia Flash Video [6–9] that each has corresponding server, player, codec technique, and communication protocol as shown in Table 1. Of these commonly seen streaming media techniques, except for Macromedia Flash Video that uses its own developed Real Time Messaging Protocol (RTMP) [10], all other techniques support RTSP (Real Time Streaming Protocol). RTSP supports two-way communication between server and player that allows users to give instructions of “pause”, “forward”, “rewind”, “start”, and “stop” to the server via RTSP [11]. The RTMP applies to the transfer of voice coding format (Mp3, Nellymoser), video coding format (Flash Video, FLV) and Macromedia Action Message Format (AMF) between Flash Player and Flash Media Server (FMS). Its priority and compression ratio are dynamically adjusted in line with network bandwidth. RTP (Real-time Transport Protocol) is defined as an Internet protocol standard for real-time transmission of multimedia data over either unicast or multicast network services. It aims to transfer temporal information and realize synchronized streaming. RTP and RTCP (Real-time Transport Control Protocol) provide simultaneously flow control and congestion control services, for each RTCP packet contains sta-

tistical data on sent packets and lost packets. Servers can make use of such information to adjust its transmission rate [12]. The Microsoft Media Server (MMS) also features RTSP play control.

Uncompressed digital voice and video content takes considerable space, which is impractical for streaming media that features real-time reception while being subject to the availability of bandwidth. Thus multimedia data typically requires special codec to allow download over the network and instant playback. The codec process is as shown in Figure 2.

Presently streaming media applies predominantly to real-time communication and online viewing. Its other applications await development. This paper intends to make use of video server and streaming media technique to develop a remote real-time video surveillance system, and based on this real-time framework, to offer synchronous and asynchronous video on demand and data on demand functions [13,14]. The system overcomes the predicament of multimedia transmission being constrained by network bandwidth, and furthermore, enhances the play quality.

3. Remote Video Surveillance System

The video surveillance system under study comprises multiple components, including video capture, video codec, video storage, video player, user authentica-

Table 1. Commonly seen real-time video media technologies

Products Function	Macromedia Flash Video	Microsoft Windows Media Technologies	Apple QuickTime Technologies	Real Networks Real System
Codec	On2 VP6 (.flv)	Windows Media Video (.asf, .wma, .wmv)	iMovie (.mov)	RealVideo (.rm)
Server	Flash Media Server	Media Server	QuickTime Streaming Server	Real System Server
Player	Flash Player	Media Player	QuickTime Player	Real Player
Protocol	RTMP	RTCP, RTTP	RTSP, RTTP	RTCP, RTSP, RTTP

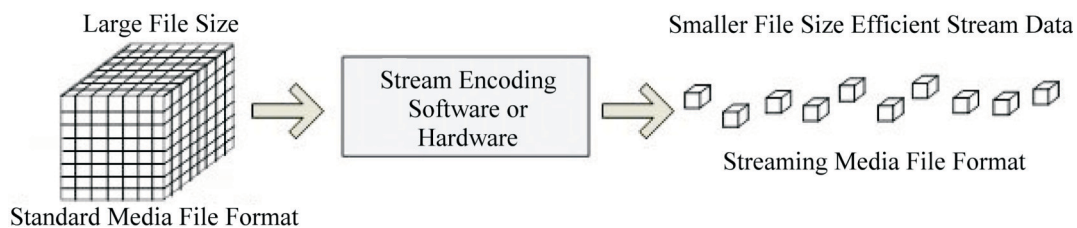

Figure 2. Streaming media codec process.

tion server, web server, video server, and network configuration as described below:

3.1 Video Capture

Camera-side user uses web browser (HTTP) to obtain video capture interface provided by web server (Figure 3) to connect to, for example, 2.4G wireless web camera, USB web camera, or IEEE-1394 digital video (DV). Each interface can connect up to four cameras. The captured images are sent to a video server at server-side via stream protocol for real-time stream transmission.

3.2 Video Codec

In light of the improved video quality offered by Macromedia Flash 8.0, the system uses the VP6 codec (compressor/decompressor) technology from On2. In comparison with Spark codec adopted by Flash MX (including Flash 6.0 and 7.0), VP6 codec offers the following advantages [15,16]:

- Support multi-pass encoding.
- High configurable data rate control.
- Direct access to the reconstruction buffer.
- Multiple-platform support (Intel, Equator, TI, PowerPC).
- Configurable sharpness control that allows adjustment of subjective quality of output.
- More condensed file size.
- Produces output with PSNR (Peak Signal-to-Noise Ratios) that are consistently better than Windows Media 9 and Real Networks Real System on a number of tests as shown in Figure 4. Equations for measuring PSNR are as shown in Equation (1) and Equation (2). Higher PSNR means better picture quality; if PSNR exceeds 40dB, human eyes cannot discern the difference between video signals before and after processing.

$$MSE = \left(\frac{1}{n}\right)^2 \times \sum_{i=1}^n \sum_{j=1}^n (\alpha_{[i,j]} - \beta_{[i,j]})^2 \quad (1)$$

$$PSNR = 10 \times \log_{10} \frac{255^2}{MSE} \text{ dB.} \quad (2)$$

3.3 Servers

The system uses three servers, namely web server, video server and user authentication server. Web server provides the interface between users on two sides (camera side and surveillance-side). The surveillance side uses web browser to establish sites under surveillance (referred to as “camera-side”) via the Internet. Video server provides the function of real-time audio/video stream transmission and management. The use of video server offers the following advantages:

- More effective use of network bandwidth.
- Clients receive better audio/video quality.
- Support the online of large number of users.
- Multiple transmission options.
- Protection of multimedia content against reproduction.

In addition, to prevent unauthorized access to the system, a user authentication server is used to authenticate authorized users (Figure 5).

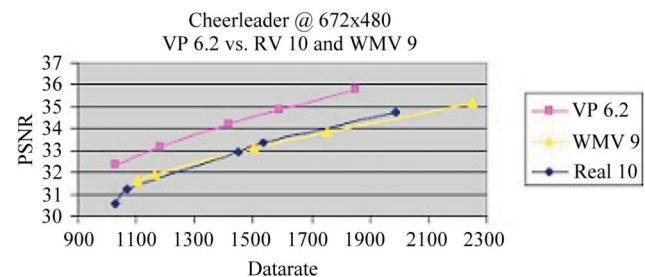

Figure 4. PSNR measure of video quality output.

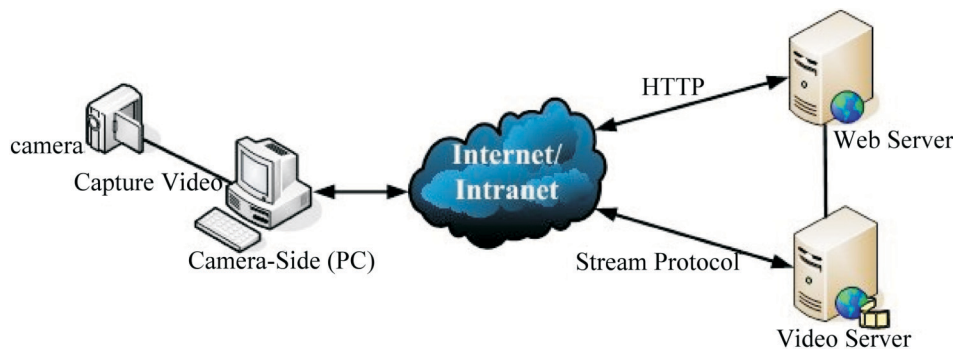

Figure 3. Camera-side video capture.

3.4 System Configuration

The framework of the system configuration is shown in Figure 6. Using a PC, notebook, PDA, or 3G mobile phone, the users can connect to the web server via the Internet at any place to login into the web-based surveillance management system (server side). The interface provided by the web server allows remote photographing configurations such as motion detection, and scheduled recording for the dynamically connected remote cameras. The video server uses proprietary streaming protocol to send video images continuously to the surveillance side as well as preserves streaming video in the video database. On the other hand, the camera side can serve as PC-based web-cameras, digital video camera or wireless web-cameras. They can be dynamically plugged in at any surveillance places via the Internet.

Instead of conventional space occupied monitoring center, the surveillance side is a web-based many-to-

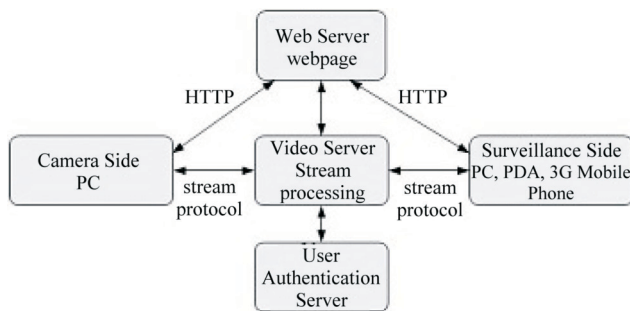

Figure 5. Server-side data processing and user authentication.

many watching center. The managers can real-time inspect all of the surveillance spots and converse with designate scene through the Internet without time and spatial limitations.

4. Construction of the Video Surveillance System

To put into effect the concept of video server, this study researches thoroughly development tools available on the market, and ultimately chose the Macromedia Flash coupled with FMS to develop the Remote Real-Time Video Monitoring System. FMS is a video server level application system. The Flash Action Script is an object-oriented programming language [17]. By combining FMS and Flash Action Script, we can engage in multiuser and multiprocessing application and video streaming transfer. The early version of Flash stores the video content frame by frame that creates huge files and thereby limits its use and scope of application. In Flash MX, Macromedia uses a proprietary streaming format – Flash Video (FLV), which incorporates the Sorenson codec technique developed by Spark. The latest version of Flash 8 features in addition the new On2 VP6 compressor that offers optimum playback quality, can both play and send data streams generated by FMS, and support live video.

This study uses Macromedia Flash 8 to develop the client-side application and employs the Apache web

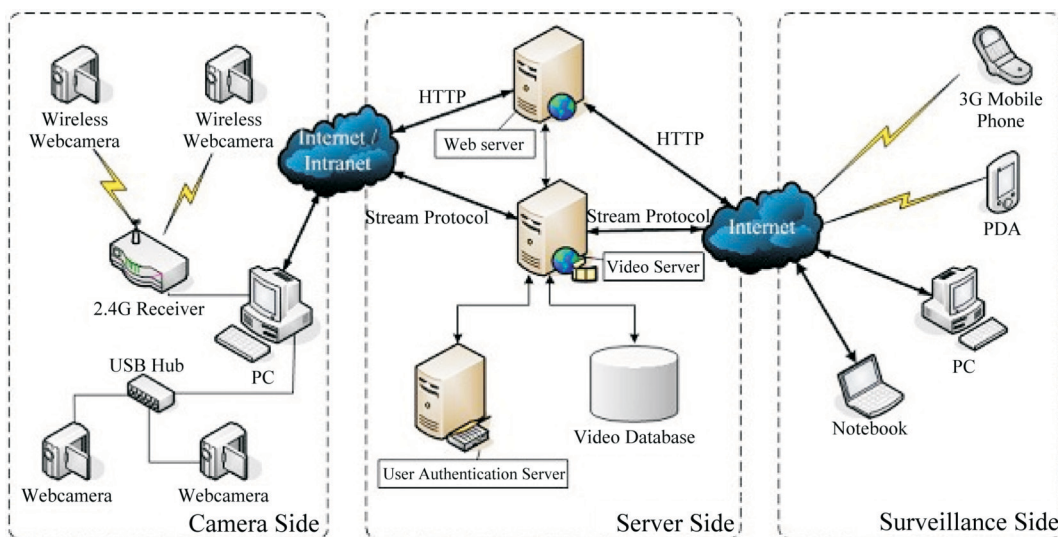

Figure 6. Physical configuration of the remote real-time video surveillance system.

server coupled with FMS2.0 installed on Linux Fedora core4 as video server, and Macromedia Breeze5.0 as user authentication server. The proposed remote surveillance system can be compartmentalized into three parts based on the configuration described as:

1. Camera side: Transmit images captured by wireless or wired camera to FMS server. The current system design can serve 16 web cameras simultaneously.
2. Server side: Comprised of Web server, FMS Server, and Breeze Server.
3. Surveillance side: The PC, notebook, PDA or 3G mobile phone of a user to achieve remote real-time video surveillance based on video images transmitted over the Internet from multiple cameras installed at multiple locations.

The communication between the three sides is achieved via TCP/IP and RTMP protocols (Figure 7), while the camera site has the options to instantly encode the video images and send to FMS Server by means of live streaming (Figure 8) or recorded streaming (Figure 9). The difference between the two means is whether stream is recorded on video server. In the case of recorded streaming, a video database can be created to facilitate viewing and tracking at a later date.

4.1 Functions of FMS Server and User Authentication Server

Of the three servers employed by the system under study, web server is not the focus of discussion and will be not elaborated. In the following section, we will describe in greater details the construction and functions of the FMS server and user authentication server.

4.1.1 FMS Server

A complete set of client-server application can be divided into two components – client-side presentation and server-side application. The former constitutes html and swf documents online users can browse; the latter constitutes FMS management of main.asc, server-side ActionScript, shared objects, flv, and other documents set by server-side application files as shown in Figure 10.

Webpages can communicate with web server through HTTP protocol, but server-side application files need to go through RTMP to communicate with FMS [6]. Thus using Flash Player directly to read the server-side application files needs to go through FMS server. In case of a local system, the client-side presentation of completed server-side application files (i.e. html and swf documents) needs to be placed in web server for access by users via browser. Figure 11 depicts the flow process



Figure 7. Audio/video transmission framework under FMS.

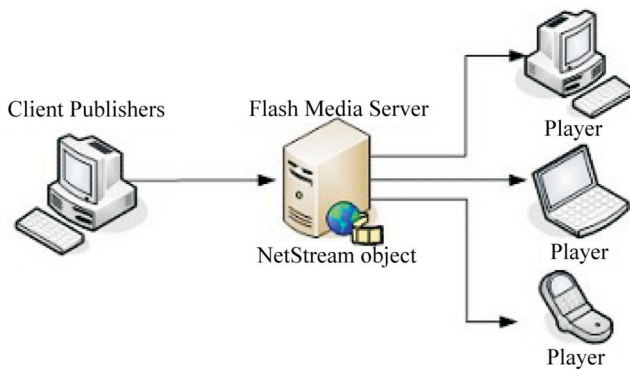

Figure 8. Live streaming transmission.

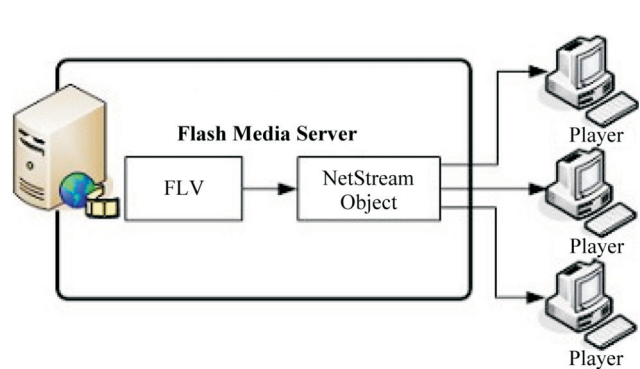

Figure 9. Recorded streaming transmission.

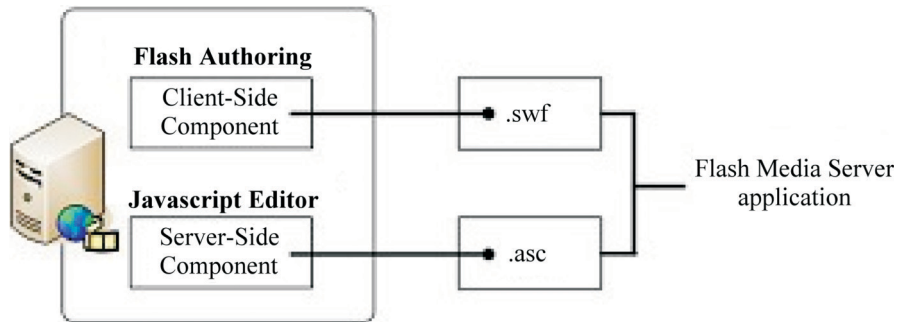

Figure 10. FMS configuration.

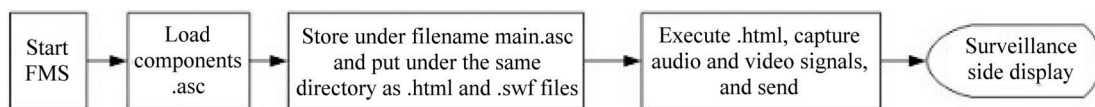

Figure 11. Flow process for real-time sharing of stream data.

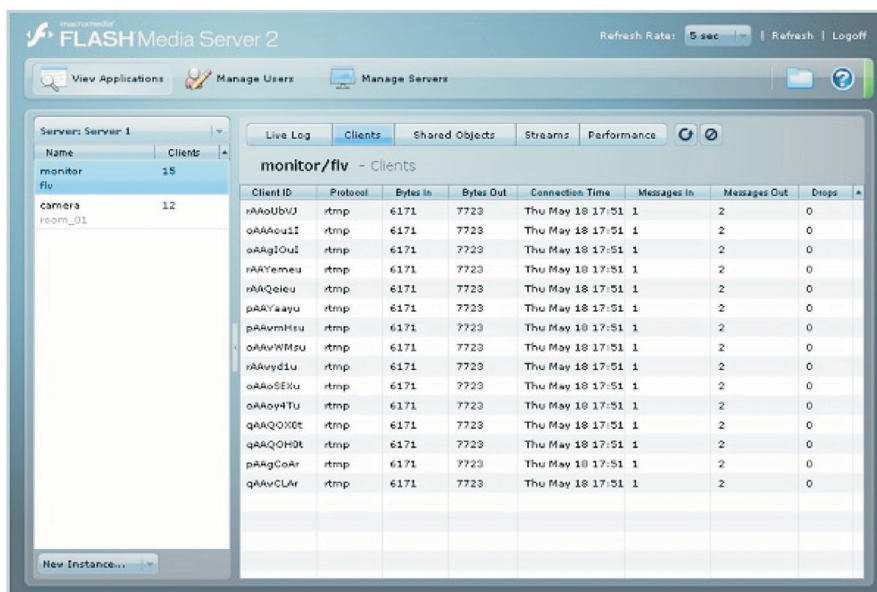

Figure 12. FMS server side management interface.

for real-time sharing of stream data.

If a Netstream object is created, stream data can be played on Flash 6.0 or higher if FMS is used. Netstream object can also play, pause and stop the stream data through NetConnection Object.

4.1.2 User Authentication Server

Any user that intends to access files in FMS server must first pass the ID authentication of Breeze server, including user name and password (Figure 13), and then

connects to browser and works under a temporary session cookie, including access to mainly Web, XML and API files. Authenticated users can simultaneously access multiple streams with different content.

4.1.3 Surveillance-Side Receiving and Playing Stream Data

Users that pass the authentication of User Authentication Server can read via a browser and retrieve the multi-point signals from camera side. Figure 14 shows

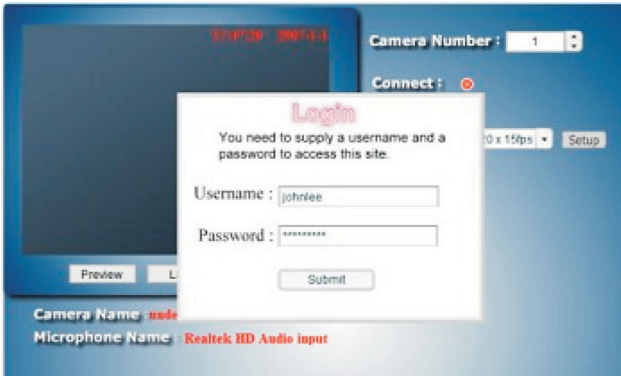

Figure 13. Login camera site images – user ID authentication.



Figure 14. Camera-side user interface.

the camera-side interface, where each connected web camera can set its capture parameters individually. The automatic facilities including motion detection, alarming signal and email sending can be triggered by the following algorithm according to the setup by camera side interface as shown in Figure 14.

Algorithm detection_trigger

Input:

- Camera_activity: **boolean**;
- Camera_id: **integer**;
- motion_level: **integer** {minimum value 0; maximum value 100};

Output:

- Video: flv streaming data;

begin

```

1 if camera_activity then
2   capture framei;
3   again:
4   capture framei+1;
5   set bg_change=difference(framei+1, framei);
6   if bg_change < motion_level then
7     goto again;
8   else
9     RecordOn "test.flv", 20 sec;
10    RecordOff;
11    if sendmail_flag then
12      sendmail abc@your.mail.server, "test.flv";
13    end if
14    if alarming_flag then
15      play alarm;
16    end if
17  end if

```

```

18 end if
19 end detection_trigger

```

Figure 15 is the surveillance side interface, which provides a web-based multi-point monitors. Through this interface, the automatic alarming message will be a when detecting an invader. The surveillance manager can also get into conversation with people in the specific scene via the real-time video dialog.

5. Comparison and Testing of Surveillance Systems

To depict further the practical merits of the proposed system, the system is compared with other video surveillance systems on the market (Table 2) and found to have significant advantages in terms of number of camera installable, automatic detection ability, automatic alarm function, multi-point surveillance, or hardware expand-



Figure 15. Surveillance-side user interface.

Table 2. Comparison of the proposed system with other systems

System name	WCSA440C [18]	NetDVR (YK-9816) [19]	Webcam watchdog [20]	Proposed System
Video format	wmv	mjpeg	avi	flv
Number of camera installable	4	16	Unlimited	Unlimited
Automatic detection	Yes	Yes	No	Adjustable detection
Automatic alarm	Alarm broadcast	Alarm broadcast	Alarm broadcast	Alarm broadcast
Automatic reminder	By phone	No	By E-mail or ICQ	By E-mail or sending audio/video signals
Multi-point surveillance	No	No	No	Multi-point real-time video surveillance through web
Support all kinds of browser with installing extra software	Yes	No	No	Yes
Require computer server	Yes	Yes	Yes	Yes
Able to use Web Cam, DV, CCTV, and IP camera	Can't use Web Cam or DV	Can't use DV	Can't use DV	Can use all
Able to use PDA and 3G mobile phone	No	No	No	Can use all
Website	www.webcamsoft.com	www.yoko-tech.com	www.webcam123.com	http://210.70.82.232/wei/monitor/all_camera-seg.html (surveillance side) http://210.70.82.232/wei/monitor/camera_client-new.html (for camera side)

ability. For enterprises or individuals that intend to install a remote real-time surveillance, the proposed system is unquestionably economical, practical, and effective.

5.1 Features of the Proposed System

1. Many-to-many remote surveillance to meet the real-time and mobility demands.
2. Surveillance points can be set up on wired or wireless network with being confined by distance.
3. Allowing the installation of multiple units of CCTV, DV, web-cam, IP-camera, and DC via the serial port, parallel port, USB, and IEEE-1394 on computer.
4. Any web server is turned into a control room without the need to construct a dedicated control room that helps lower personnel, equipment and management costs.
5. Digital, adjustable motion detection, real-time alert and evidence collection to achieve intelligent surveillance.
6. Enhanced intelligent surveillance system and alarm function to minimize human errors.
7. Convenient installation and low cost will render surveillance system more prevalent to help maintain public order and fight crimes.
8. Requiring only web browser and Flash player for operation without the need to install extra software.
9. Open configuration allows users to add or remove surveillance points and makes installation and operation convenient and easy.
10. Transmission over the Internet cuts down the costs of wiring and construction to build a flexible or dedicated surveillance environment.
11. Applicable to an extensive range of fields.

5.2 Measurement of the Experimental Results

This study uses sixteen cameras simultaneously to measure the data flow of video server (Figure 16). When the motion detection value of each camera is below 50%, it means there is no near objects moving in front of the lens of each camera; if there are moving objects, they must be at a spot farther away from the lens, and the overall aspect ratio is below 10%. Under such scenarios, the use of camera CPU is also below 50%, and the net-

work flow curve is under 1.5 megabits/sec with each camera taking up about 96 kilobits/sec (1.5 Megabits/16) bandwidth, indicating system performance is at its best and the network traffic is low at this time. When the motion detection value of a camera is kept constantly at 70%~100%, the flow curve will rise instantly; if the motion detection values of several cameras are over 50% and kept at that level for at least 20 seconds, the network flow will rise to 23 megabits/sec. If the motion detection values of several camera drop, the network flow curve will also fall drastically to 1.5 megabits/sec, indicating good performance of streaming media that when massive audio/video stream data are sent, the transmission is normal and the picture quality is not affected. When the motion detection values of all sixteen cameras reach 100%, the picture-on-picture (POP) display will have only 1 to 2 seconds of delay (Table 3).

6. Conclusion and Future Work

In this paper, we have implemented a hardware-independence framework for developing a real-time surveillance system based on Flash streaming media server technique. The proposed system allows user to setup multiple cameras dynamically via the Internet to create a multipoint-to-multipoint surveillance environment without the constraints of distance, and number of user. Hence, users at any places can real-time watch the surveillance video at different locations over the world-wide. Based on FMS streaming technology, the proposed surveillance system can instantly re-allocate bandwidth according to changes taken place at the sources of signals to make the best use of available bandwidth and ensure smooth flow of video signals.

Looking into the future, spurred by the needs to fight crimes and terrorism, the demands for surveillance ca-

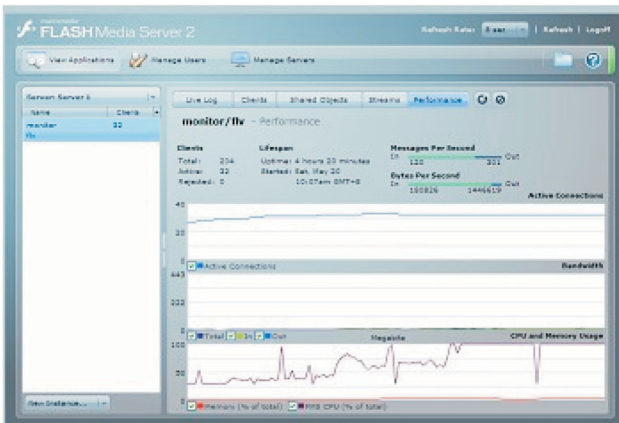

(a) FMS Performance Chart

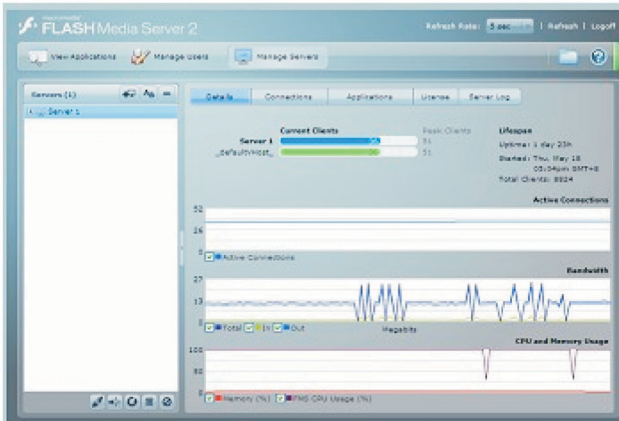

(b) FMS Details Chart

Figure 16. Measurements of video server streaming.

Table 3. Measurements of video server streaming and smooth streaming performance

Number of camera	Motion detection value	Input/output flow	CPU usage	Smooth stream performance
16	< 50%	< 1.5Megabits/sec	< 50%	Best
16	> 50% continuously for more than 20 seconds	≈ 23Megabits/sec	100%	1-2 seconds of POP display delay
1~8	> 50% continuously for more than 20 seconds	≈ 23Megabits/sec	100%	Normal (no picture delay)
16 POP streaming broadcasting	Motion detection not activated	< 1.5Megabits/sec	< 50%	Normal (no picture delay)

mera are expected to rise rapidly. We have revealed that the development of intelligent web-based real-time video surveillance system to replace some of the manned surveillance system is the trend. The proposed system offers the benefits of low hardware costs, easy software development, easy application, good performance, highly practical, and wide applications.

In the future research, some autonomous facilities such as in-and-out motion detection algorithm and object moving tracking algorithm will be considered in the framework to carry out an intelligent surveillance system [21,22]. In addition, based on the configuration of real-time video server, a wide range of applications can also be developed, for example, multiparty video conference, distance video learning, video healthcare, home care, video chat room, and digital homes, synchronous and asynchronous video on demand, and data on demand.

References

- [1] Alan, J. L., Craig, H. H., Niels, H. and Donald, M., *Critical Asset Protection, Perimeter Monitoring, and Threat Detection Using Automated Video Surveillance*, Object Video White Paper (2004).
- [2] Tobias, K., *Streaming Media: Technologies, Standards, Applications*, Wiley Publishing, Inc. (2003).
- [3] Gregory, C., Demetriades. *Streaming Media: Building and Implementing a Complete Streaming System*, Wiley Publishing, Inc. (2002).
- [4] Real Networks Home Page. <http://www.realnworks.com/> (2009).
- [5] Apple Quick Time Home Page. <http://www.apple.com/quicktime/win.html> (2009).
- [6] Adobe Home Page. Flash Media Server, <http://www.adobe.com/products/flashmediaserver/> (2009).
- [7] Adobe Home Page. Flash Media Server Documentation, <http://www.adobe.com/support/documentation/en/flashmediaserver/> (2009).
- [8] Adobe. *Macromedia Flash Media Server 2.0 user guide* (2005).
- [9] Kirstian, B., Hoss, G., Brian, M. and Todd, M., *Macromedia Flash MX Video*, Springer-Verlag (2002).
- [10] Lesser, B., Guilizzoni, G., Lott, J., Reinhardt, R. and Watkins, J., *Programming Flash Communication Server*, 1st ed. O'Reilly Inc. (2005).
- [11] Schulzrinne, H., Rao, A. and Lanphier, R., *Real Time Streaming Protocol (RTSP)*, RFC2326 (1998).
- [12] Tommi, K., *Protocol Overview: RTP and RTCP*, Nokia Telecommunications Home Page. <http://www.netlab.tkk.fi/opetus/s38130/k99/presentations/4.pdf> (1999).
- [13] Foresti, G. L., "A Real-Time System for Video Surveillance of Unattended Outdoor Environments," *IEEE Trans. Circuits System. Video Tech.*, Vol. 8, pp. 697–704 (1998).
- [14] Wolf, W., Ozer, B. and Lv, T., "Smart Cameras as Embedded Systems," *IEEE Computer*, Vol. 35, pp. 48–53 (2002).
- [15] On2 Technologies, Inc. *WHITE PAPER Advantages of TrueMotion VP6 Technology*, February 17 (2004).
- [16] ActionScript.org Press, *On2 VP6 Compression Technology Optimizes Highly Anticipated Macromedia Flash Player 8 for Highest Image Quality on the Internet*, Home Page: <http://www.on2.com/company/news-room/press-releases/?id=304> (2006).
- [17] Luar, *Flash ActionScript 2.0 RIA Programming Development*, Taiwan, GrandTech (2004).
- [18] WCSA440C Home Page. <http://www.webcamsoft.com/tw/wcsa440c.html>; 2009.
- [19] NetDVR Home Page. <http://www.yoko-tech.com> (2009).
- [20] Webcam Watchdog Home Page. <http://www.webcamsoft.com/tw/watchdog.html>.
- [21] Wren, C., Azarbayejani, A., Darrell, T. and Pentland, A., "Pfinder: Real-Time Tracking of the Human Body," *IEEE Transactions on Pattern Analysis and Machine Intelligence*, Vol. 19, pp. 780–785 (1997).
- [22] Segen, J. and Pingali, S., "A Camera-Based System for Tracking People in Real Time," *Proc. IEEE International Symposium on Pattern Recognition*, Vol. 3, pp. 63–67 (1996).

Manuscript Received: Nov. 21, 2007

Accepted: Aug. 27, 2009