

Instituto Tecnológico y de Estudios Superiores de Occidente

Repositorio Institucional del ITESO

rei.iteso.mx

---

Departamento de Electrónica, Sistemas e Informática

DESI - Artículos y ponencias con arbitraje

---

2017-10

# Design Optimization of a Planar Spiral Inductor Using Space Mapping (poster)

Leal-Romo, Felipe J.; Cabrera-Gómez, Marisol; Rayas-Sánchez, José E.;  
García-Mora, Daniel M.

---

F.J. Leal-Romo, M. Cabrera-Gómez, J.E. Rayas-Sánchez and D.M. García-Mora. "Design optimization of a planar spiral inductor using space mapping," in Int. Conf. Electrical Performance of Electronic Packaging and Systems (EPEPS 2017), San Jose, CA, Oct. 2017 (poster).

Enlace directo al documento: <http://hdl.handle.net/11117/5953>

*Este documento obtenido del Repositorio Institucional del Instituto Tecnológico y de Estudios Superiores de Occidente se pone a disposición general bajo los términos y condiciones de la siguiente licencia:*  
<http://quijote.biblio.iteso.mx/licencias/CC-BY-NC-ND-2.5-MX.pdf>

*(El documento empieza en la siguiente página)*

## 0. ABSTRACT

This paper addresses the implementation of a computationally efficient optimization technique for designing structures simulated in 3D electromagnetic field solvers. A probe of concept is done by the EM-based optimization of a planar spiral inductor for high-power applications. The optimization technique employed is based on space mapping (SM) methods, more specifically on the Broyden-based input space mapping algorithm. Our optimization results confirm the efficiency of the proposed approach.

## 1. INTRODUCTION

Aiming at developing a practical tool for the design optimization of such large circuits, in this paper we propose, as a proof of concept, a computationally efficient automated approach to optimize the geometry of spiral inductors simulated in Cadence® Sigriy™ PowerSI® 3D EM (PSI-3D) [1]. We first describe the spiral structure of interest [2]. Then, we implement the selected spiral inductor in PSI-3D, comparing our simulation results with those in [2]. The resultant PSI-3D model, which is highly accurate but computationally expensive, is taken as our fine model in the context of space mapping optimization [3]. Next, we implement the same inductor in a high-frequency circuit simulator, which is exploited as a coarse model (very fast, but insufficiently accurate). We develop adequate Matlab drivers for these fine and coarse models. Finally, we employ the Broyden-based input space mapping algorithm, better known as aggressive space mapping (ASM) [4,5], as the selected optimization technique to fine tune the geometrical dimensions of the spiral inductor in an automated and efficient manner.

## 2. INDUCTOR STRUCTURE

As mentioned before, the selected spiral inductor is intended for relatively high-power applications [2]. Its main geometrical dimensions are shown in Fig. 1. This inductor has 1.5 turns, it is built with copper and utilizes 99.5% pure Alumina ( $Al_2O_3$ ) as substrate material. Its complete dimensions and material properties are shown in Table I.

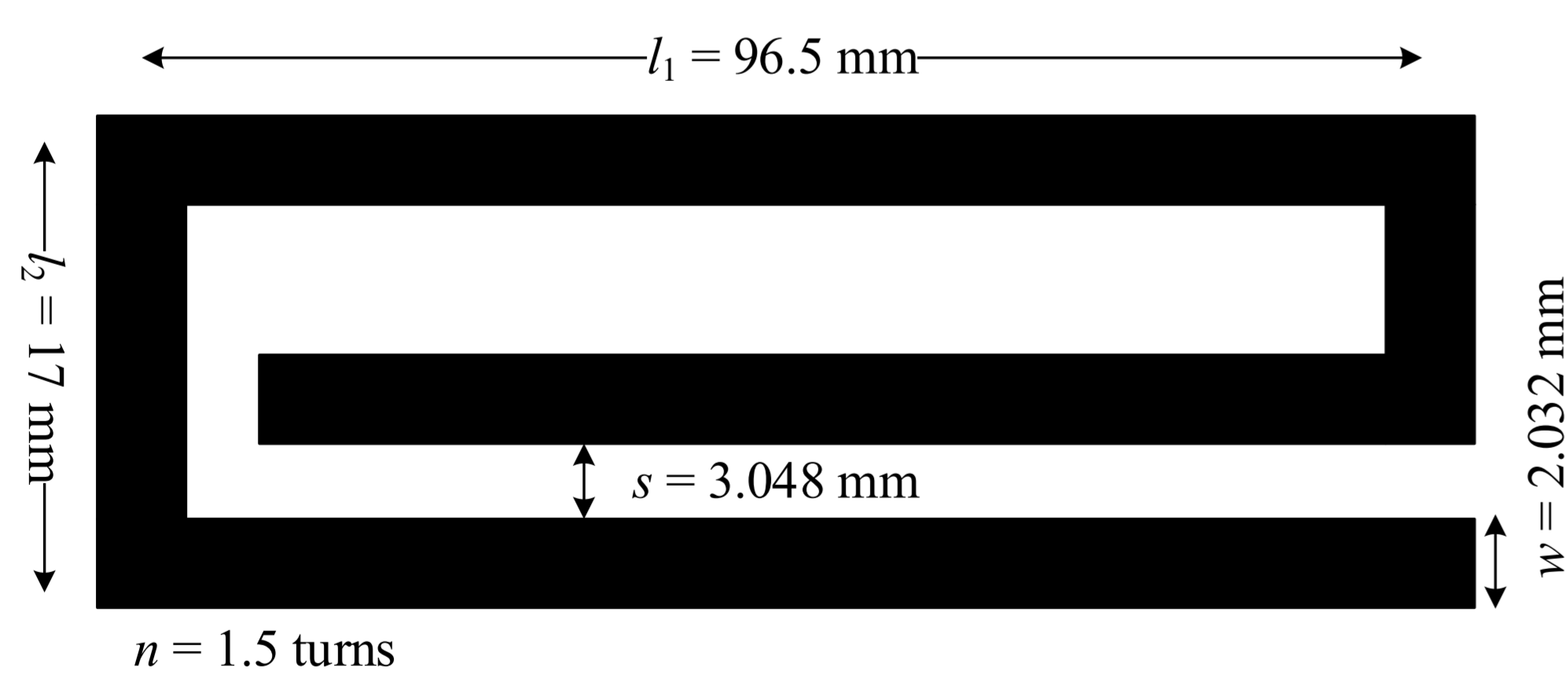

Fig. 1. Spiral Inductor's dimensions for power applications [2].

TABLE I  
SPIRAL INDUCTOR PHYSICAL PARAMETERS

| Parameter's Name           | Initial Value     | Final Value       |
|----------------------------|-------------------|-------------------|
| $l_1$ (mm)                 | 96.5              | 83.11             |
| $l_2$ (mm)                 | 17                | 16.22             |
| $s$ (mm)                   | 3.048             | 4.48              |
| $w$ (mm)                   | 2.032             | 16.59             |
| $H$ (mm)                   | 2.54              | 2.54              |
| $t$ (mm)                   | 0.3048            | 0.3048            |
| $n$ (turns)                | 1.5               | 1.5               |
| $\epsilon_r$ ( $Al_2O_3$ ) | 9.8               | 9.8               |
| $\rho$ (CuAu)              | 0.7066            | 0.7066            |
| $\sigma$ (S/m)             | $5.8 \times 10^7$ | $5.8 \times 10^7$ |
| $\tan \delta$              | 0.0001            | 0.0001            |

## 3. FINE MODEL (PSI-3D)

The inductor is contained inside a boundary box at least three times taller than the total substrate height plus the inductor and the reference plane, and two times wider and larger than the spiral inductor structure, such that the electromagnetic fields in the structure do not interact with the enclosing box (Fig. 2).

The inductance value of interest is measured at 13.5 MHz, while the resonance frequency  $f_r$  is expected to happen at around 90 MHz.

Table II summarizes the parameters obtained in our PSI-3D simulation vs. those reported from the simulation in [2]

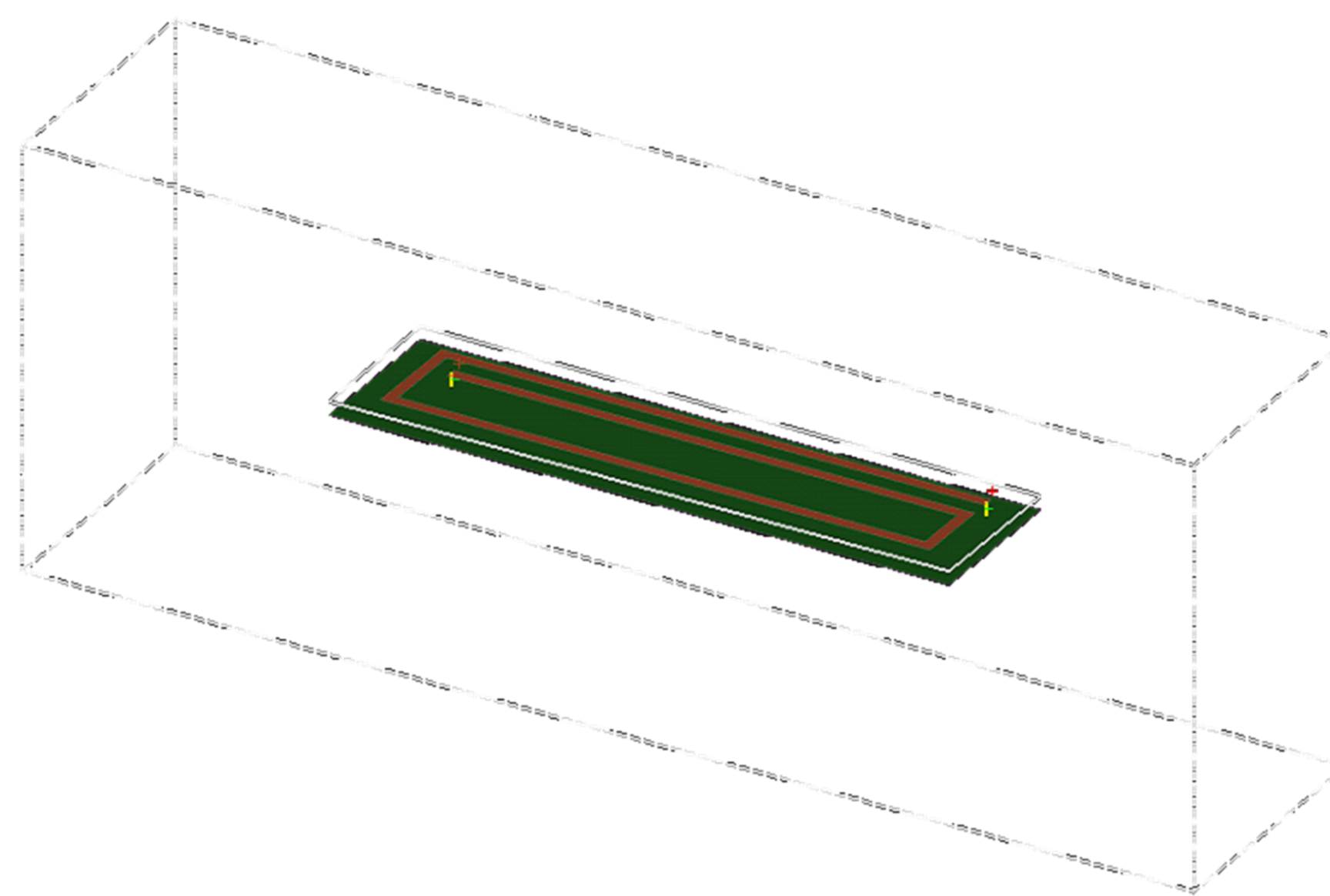

Fig. 2. Implementation of the 1.5 turns spiral inductor in PSI-3D.

TABLE II  
SONNET VS PSI-3D RESULTS

| Simulator  | $L$ (nH) @ 13.5 MHz | $f_r$ (MHz) |
|------------|---------------------|-------------|
| Sonnet [2] | 132.78              | 92.5        |
| PSI-3D     | 130.5               | 89.12       |

## 4. COARSE MODEL (APLAC)

In APLAC, we assume the same material properties as well as the same initial geometrical dimensions as those used for the fine model (Fig. 3).

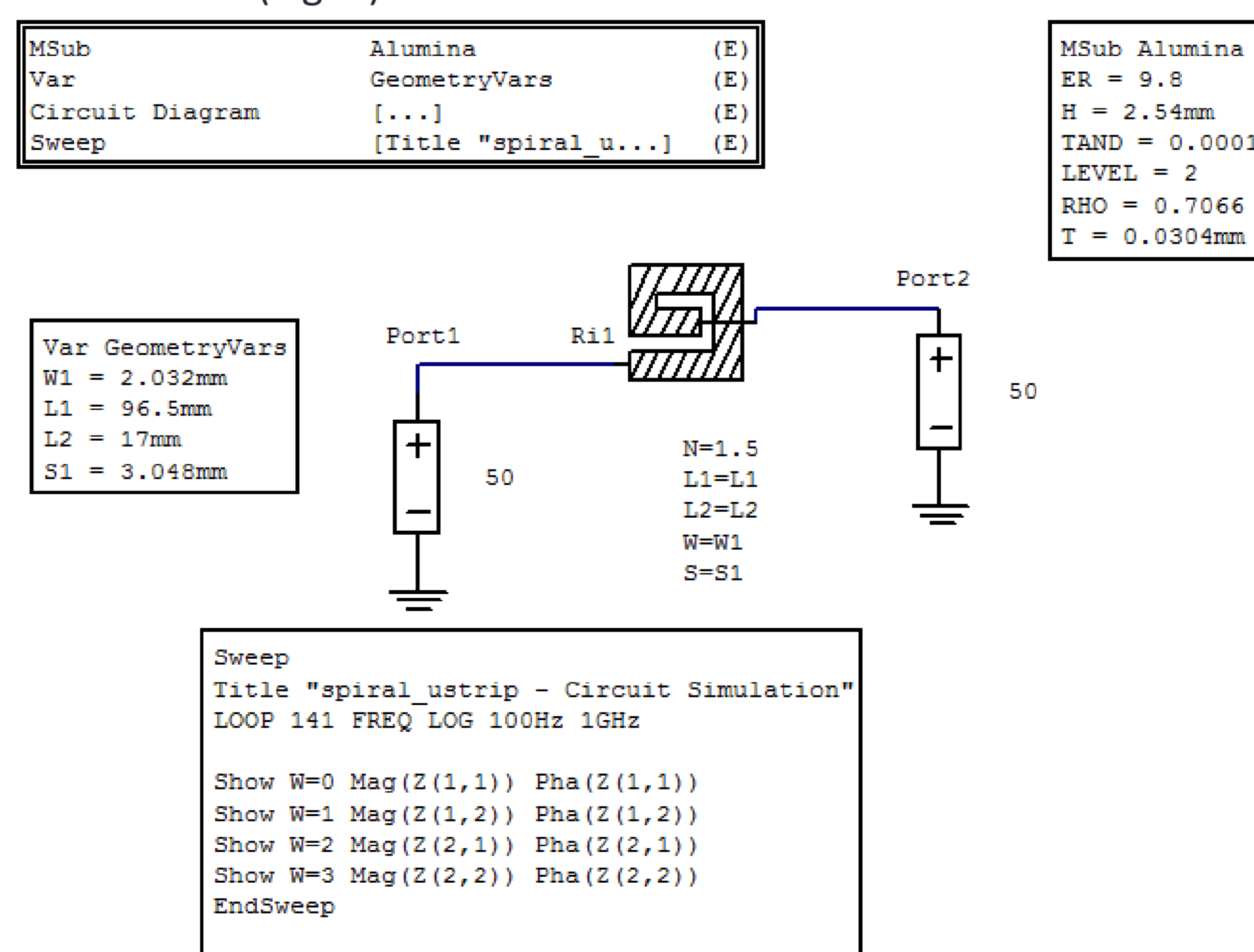

Fig. 3. Implementation of the 1.5 turns spiral inductor in APLAC.

## 5. SM OPTIMIZATION

To test our optimization algorithm, the spiral inductor is optimized by implementing the ASM algorithm [5] in Matlab, as depicted in Fig. 4.

To comply with our own high-power design, the problem was formulated to meet the following specifications:

$$L_{AC} \leq 115 \text{ nH for } 10 \text{ MHz} \leq f \leq 16 \text{ MHz} \quad (1)$$

$$R_{AC} \geq 90 \text{ m}\Omega \text{ for } 100 \text{ Hz} \leq f \leq 1 \text{ kHz} \quad (2)$$

The optimization variables are  $x = [w \ l_1 \ l_2 \ s]^T$ , keeping fixed the preassigned parameters  $y = [H \ t \ n \ \epsilon_r \ \rho \ \sigma \ \tan \delta]^T$ .

In Fig. 5, we display the relative error of  $R_f(x_f) = [L_{AC} \ R_{AC}]^T$  along the 8 PSI-3D runs; we meet the desired target response described by (1) and (2) with an error tolerance smaller than  $5 \times 10^{-3}$  in 8 fine model simulations.

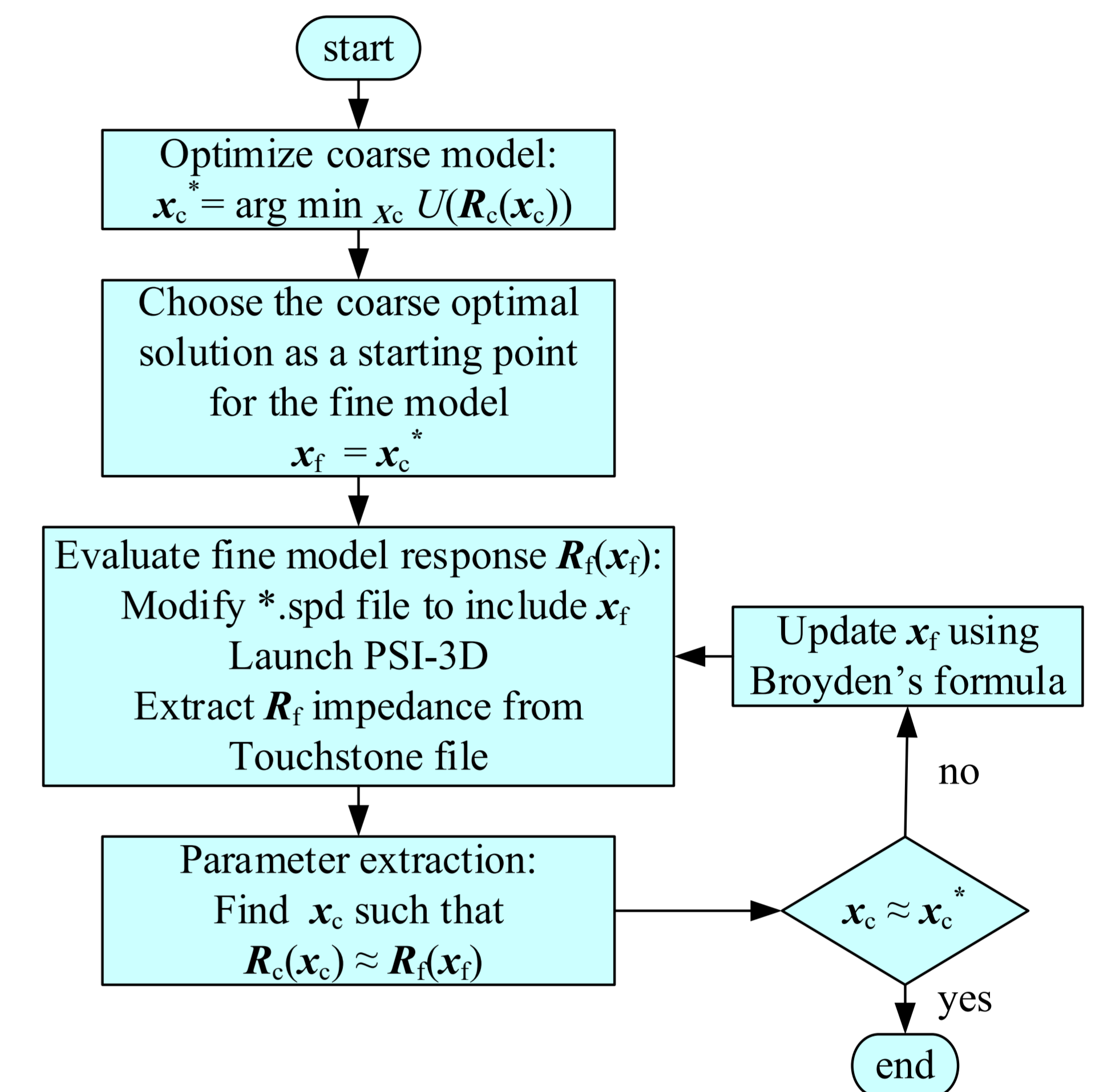

Fig. 4. Aggressive Space Mapping (ASM) algorithm.

Evolution of Fine Model Responses with Respect to Targets

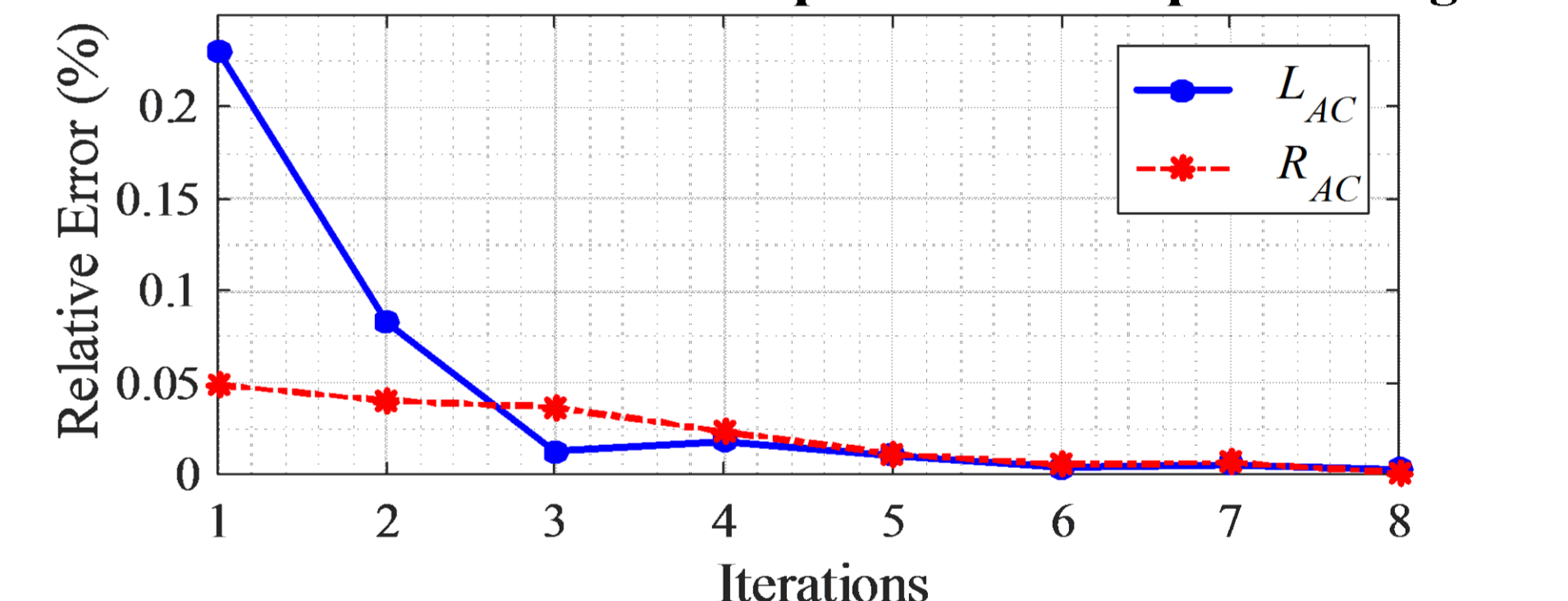

Fig. 5. Relative error of the fine model's  $L_{AC}$  and  $R_{AC}$  with respect to target.

## 6. CONCLUSIONS

Our proposed optimization methodology was tested with the successful implementation of the ASM method to fine tune the geometry of the spiral inductor structure using APLAC's equivalent circuit as the coarse model and PowerSI® 3D EM as the fine model. The optimization process achieved desired results for  $L_{AC}$  and  $R_{AC}$  in specific frequency ranges, with a few iterations of the fine model, while the coarse model required more than a hundred of simulations to achieve the desired goal, which are executed in a negligible time.

## 7. SELECTED REFERENCES

- [1] Cadence Design Systems, Inc. (2016). *Sigriy PowerSI 3D EM Extraction option* [Online]. Available: [https://www.cadence.com/content/cadence-www/global/en\\_US/home/tools/ic-package-design-and-analysis/si-pi-analysis-point-tools/sigriy-powersi-3d-em-extraction-option.html](https://www.cadence.com/content/cadence-www/global/en_US/home/tools/ic-package-design-and-analysis/si-pi-analysis-point-tools/sigriy-powersi-3d-em-extraction-option.html).
- [2] A. Eroglu, "Planar inductor design for high power applications," *Progress in Electromagnetics Research B*, vol. 35, pp. 53-67, Oct. 2011.
- [3] J. W. Bandler, Q. Cheng, S. A. Dakrouy, A. S. Mohamed, M. H. Bakr, K. Madsen and J. Søndergaard, "Space mapping: the state of the art," *IEEE Trans. Microwave Theory Tech.*, vol. 52, no. 1, pp. 337-361, Jan. 2004.
- [4] J. W. Bandler, R. M. Biernacki, S. H. Chen, R. H. Hemmers, and K. Madsen, "Electromagnetic optimization exploiting aggressive space mapping," *IEEE Trans. Microw. Theory Techn.*, vol. 41, no. 12, pp. 2874-2882, Dec. 1995.
- [5] J. E. Rayas-Sanchez, "Power in simplicity with ASM, tracing the aggressive space mapping algorithm over two decades of development and engineering applications," *IEEE Microw. Mag.*, vol. 17, no. 4, pp. 64-76, Apr. 2016.