

# REWARD PROCESSING UNDER INFLUENCE: EFFECTS OF STRESS AND COGNITIVE LOAD ON REWARD PROCESSING, AND THEIR CLINICAL IMPLICATIONS FOR THE VULNERABILITY TO MAJOR DEPRESSION

## **Doctoral thesis - Thèse de doctorat**

Presented at the Faculty of Humanities of the University of Fribourg (Switzerland)  
Specialized in Clinical Psychology and Affective Neuroscience

Présentée à la Faculté des Lettres et des Sciences humaines de l'Université de Fribourg (Suisse)  
Spécialisée en Psychologie Clinique et Neurosciences affectives

Presented by - Présentée par

**Claudie GAILLARD**

(La Roche, Suisse)

Approved by the Faculty of Humanities on the proposal of  
Prof. Dr. Chantal MARTIN SOELCH (first examiner),  
Prof. Dr. med. Gregor HASLER (second examiner) and  
P.D. Dr. med. Petra SCHWEINHARDT, PhD (third examiner)

Approuvée par la Faculté des Lettres et des Sciences humaines sur proposition de  
la Prof. Dr. Chantal MARTIN SOELCH (première rapporteure),  
Prof. Dr. med. Gregor HASLER (deuxième rapporteur) et  
P.D. Dr. med. Petra SCHWEINHARDT, PhD (troisième rapporteure)

Fribourg, 7<sup>th</sup> of June 2019 - Fribourg, le 7 juin 2019

Prof. Dr. Bernadette CHARLIER, Dean - Doyenne



This doctoral thesis was directed by the Professor Dr. Chantal MARTIN SOELCH.

The Research Pool of the University of Fribourg (n° 578) and a grant from Gottfried und Julia Bangerter-Rhyner-Stiftung (n° 8472) supported this doctoral thesis.

Many thanks also to the Swiss National Science Foundation (SNSF) for having supported my Doc.Mobility [n° P1FRP1\_174818] at the National Institutes of Mental Health (NIMH), Bethesda, USA.

**Thesis examination committee:**

Prof. Dr. Chantal MARTIN SOELCH, University of Fribourg, thesis director, examiner

Prof. Dr. med. Gregor HASLER, University of Fribourg, examiner

P.D. Dr. med. Petra SCHWEINHARDT, University of Zurich, examiner

Prof. Dr. Dominik SCHOEBI, University of Fribourg, President of the examination committee

Prof. Dr. Roberto CALDARA, University of Fribourg, assessor

Prof. Dr. Bernadette CHARLIER, University of Fribourg, assessor

Fribourg, 7<sup>th</sup> of June 2019

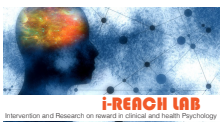





## ABSTRACT

---

Humans have a propensity to pursue rewards and to avoid punishments. The motivation to seek rewards and the ability to experience and to learn from positive consequences are fundamental functions in the reward processing. They promote survival and well-being. However, these functions can be challenged or impaired by stressful events or contexts. To clarify the determinant factors that might impair the normal reward function in healthy humans, this thesis has four aims. First, to investigate the brain and psychological mechanisms that foster adaptive motivated behaviors and hedonic responsiveness, and how unpredictable acute stress exposure might challenge these mechanisms. Second, to explore how the availability of cognitive regulatory processes may modulate the effect of stress exposure on these reward functions. Third, since emotion regulation strategies might improve or alter the maintenance of an adaptive reward processing, this thesis examines how the propensity to use adaptive or maladaptive emotion regulation strategies influences the responsiveness to reward delivery in healthy individuals. Of clinical importance, the fourth aim is based on the fact that major depression disorder (MDD) is characterized by a disrupted reward processing, increased stress sensitivity, and altered cognitive and emotion regulation processes. Consequently, we used the vulnerability to MDD as a clinical model to test the neural and psychological effects of stress exposure on motivated behaviors and hedonic responsiveness in healthy individuals vulnerable to MDD (HV) compared to closely matched healthy controls (HC).

Three empirical works address these aims. *Empirical work I* explores how, in healthy individuals, unpredictable acute stress exposure affects the neural and behavioral mechanisms engaged during cues predicting rewards and during reward delivery, and how cognitive effort modulates stress-related effects on reward processing. To measure brain activations during reward processing, we used an event-related functional magnetic resonance imaging (fMRI) reward task with unpredictable acute stress induced by threat-of-shock, and reward responsiveness modulated by variable reinforcement schedules (rewarded vs not-rewarded trials). The availability of cognitive regulatory processes was manipulated by two levels of cognitive effort to exert in the task (low, high working memory load). Our findings indicate that both stress exposure and increased cognitive effort influenced the striatal reactivity during the delivery phase, but these factors did not interact. In all conditions, stress exposure enhanced both dorsal striatal activation during the delivery phase and cognitive performance, while higher cognitive effort reduced both ventral striatal reactivity to reward receipt and cognitive performance.

Moving on from there, *Empirical work II* provides insight into the relationship between the propensity of healthy adults to use adaptive or maladaptive emotion regulation strategies, and their neural responsiveness to reward delivery, a measure of hedonic responsivity. Our findings demonstrate that the ventral striatal responsiveness to reward delivery was negatively associated with both the subject's tendency to use maladaptive emotion regulation strategies, and the severity and intensity of the subclinical depressive symptoms they reported.

With the aim to test the clinical implications for the vulnerability to MDD, *Empirical work III* examines whether unpredictable acute stress exposure affects differently HC's and HV's neural responsiveness to cues predicting rewards and to reward delivery when performing the reward task used in our first empirical work. In an exploratory way, we also investigate whether cognitive effort modulates differently the effect of unpredictable acute stress exposure on reward responsiveness. Our findings evidence that stress exposure reduced the ventral striatal reactivity in HV during the anticipation phase, regardless of reinforcement schedule. This stress-related effect was potentiated when individuals were asked to exert a lower cognitive effort in the task. Also, HV showed diminished dorsal striatal activation in all conditions during the anticipation phase. During the delivery phase, the exertion of higher cognitive effort decreased the ventral striatal reactivity in HV, irrespective of stress exposure and reinforcement schedule.

Overall, the findings of this thesis demonstrate that stress exposure might strengthen arousal resulting possibly in increased reward-seeking motivation and in the emergence of automatized actions at the expense of goal-directed behaviors. Our results bring new insights into the complex influence of cognitive demands and how they modulate the effect of unpredictable acute stress on the reward processing. Regarding the role played by emotion regulation, maladaptive emotion regulation strategies might have an adverse effect on the ability to experience hedonic feelings. Of clinical significance, our findings indicate finally that increased familial risk for MDD may be associated with impaired ability to encode incentive value and with dysfunctions in reward learning processes including the learning of action-outcome and stimulus-outcome associations. Altogether, the results of this thesis might open new avenues for developing efficient prevention programs promoting resilience in the face of stress exposure, and for reducing the risk for stress-related psychopathological symptoms.

## RÉSUMÉ

---

Les humains ont la propension à rechercher les récompenses et à éviter les punitions. La motivation à rechercher des récompenses et la capacité à en ressentir les effets positifs, à constater qu'un comportement a eu des conséquences positives et celle de le reproduire sont des fonctions fondamentales du traitement de la récompense. Elles promeuvent la survie et le bien-être. Cependant, ces fonctions peuvent être menacées ou altérées par l'exposition à des situations ou des contextes stressants. Afin de clarifier les facteurs déterminants qui, chez les adultes sains, sont susceptibles de porter atteinte au traitement de la récompense, cette thèse poursuit quatre objectifs. Premièrement, investiguer les mécanismes neuronaux et psychologiques qui favorisent les comportements motivés et la sensibilité hédonique, et comment l'exposition à un stresser aigu imprévisible peut affecter ces mécanismes. Deuxièmement, explorer comment la disponibilité de processus cognitifs régulateurs peut moduler les effets de l'exposition à ce stresser sur le traitement de la récompense. Troisièmement, dès lors que les stratégies de régulation émotionnelle peuvent améliorer ou altérer le maintien d'un traitement adaptatif de la récompense, cette thèse examine comment la propension à utiliser des stratégies de régulation émotionnelle adaptatives ou inadaptées influence la sensibilité à la récompense chez des adultes sains. D'une importance clinique particulière, le quatrième objectif se fonde sur le fait que le trouble dépressif caractérisé (TDC) se caractérise par un dérèglement du traitement de la récompense, une sensibilité accrue au stress et une altération des processus cognitifs et de la régulation émotionnelle. Par conséquent, en utilisant la vulnérabilité au TDC comme modèle clinique, cette thèse compare les effets neuronaux et psychologiques de l'exposition à un stresser sur les comportements motivés et la sensibilité hédonique, chez des individus présentant une vulnérabilité accrue au TDM (IV, individu vulnérable) et chez des individus sains (IC, individu contrôle). Trois études empiriques adressent ces objectifs.

Notre première étude empirique investigate comment, chez des sujets sains, l'exposition à un stresser aigu et imprévisible affecte les mécanismes neuronaux et psychologiques impliqués lors de la phase d'anticipation et de réception de la récompense, et comment l'effort cognitif requis module les effets induits par le stresser sur le traitement de la récompense. Pour mesurer l'activation cérébrale durant le traitement de la récompense, nous avons utilisé une tâche de récompense durant laquelle un stress expérimental était induit au travers de l'administration de chocs électriques, alors que le traitement de la récompense était modulé par le renforcement ou non des réponses correctes. La disponibilité des fonctions cognitives régulatrices a été manipulée en variant le niveau d'effort cognitif requis durant la tâche expérimentale (charge cognitive faible

ou élevée). Nos résultats indiquent que l'exposition à un stresser et un effort cognitif accru influence la réactivité striatale pendant la phase de réception du feedback, sans toutefois que ces deux facteurs n'interagissent. Dans toutes les conditions, l'exposition au stresser a augmenté la réactivité du striatum dorsal et les performances cognitives, alors que la nécessité d'engager un effort cognitif accru s'est traduit par une réduction de la réactivité du striatum ventral lors de la réception de récompenses et par une diminution de la performance cognitive.

Sur cette base, notre deuxième étude empirique porte sur la relation entre la propension d'individus sains à utiliser des stratégies de régulation émotionnelle adaptatives ou inadaptées et leur sensibilité cérébrale à la réception de récompenses, une mesure reflétant la sensibilité hédonique. Nos résultats suggèrent que la réactivité du striatum ventral en réponse à la réception d'une récompense est négativement corrélée à la tendance des sujets à réguler leurs émotions de manière inadaptée, ainsi qu'à la sévérité et à l'intensité des symptômes dépressifs subcliniques qu'ils rapportent.

Avec pour objectif d'explorer les implications cliniques pour la vulnérabilité au TDC, notre troisième étude empirique explore la manière dont l'exposition à un stresser affecte le traitement de la récompense chez les IV par rapport aux IC durant la phase d'anticipation et de réception de la récompense lorsque ceux-ci effectuent la même tâche expérimentale que celle réalisée dans notre première étude empirique. De manière exploratoire, nous examinons également si le niveau de l'effort cognitif à investir dans la tâche modère de manière différente l'effet du stresser sur le traitement de la récompense chez les IV en comparaison aux IC. Nos résultats mettent en évidence que l'exposition à un stresser a réduit la réactivité du striatum ventral chez les IV durant la phase d'anticipation, indépendamment d'une potentielle récompense. Cet effet induit par le stresser était renforcé lorsque l'effort cognitif annoncé était plus faible. Durant la phase d'anticipation, les IV ont également présenté une augmentation de l'activation du striatum dorsal dans toutes les conditions. Durant la présentation du feedback, une diminution de la réactivité du striatum ventral est apparue chez les IV dans la condition où un effort cognitif accru avait été investi dans la tâche expérimentale, et ce indépendamment de la présence du stresser ou de récompense.

En somme, les résultats de cette thèse indiquent que l'exposition à un stresser aigu imprévisible pourrait induire une augmentation du niveau d'éveil, menant potentiellement à une amplification de la motivation orientée vers la recherche de récompenses et à l'émergence de conduites automatisées au détriment de comportements orientés vers un but. Nos résultats apportent un nouvel éclairage sur la complexité de l'influence exercée par le niveau d'effort cognitif et sur la manière dont celui-ci modère les effets du stress sur le traitement de la récompense. Quant au rôle joué par la régulation émotionnelle, les stratégies inadaptées semblent avoir un effet néfaste

sur la sensibilité à la réception d'une récompense. D'une importance clinique particulière, nos résultats suggèrent que la vulnérabilité familiale au TDC est associée à une difficulté à encoder la valeur d'un stimulus émotionnel et à des dysfonctions dans les processus d'apprentissage en lien avec la récompense. Ainsi, les résultats de cette thèse pourraient contribuer à ouvrir de nouvelles perspectives pour le développement de programmes de prévention efficaces visant à renforcer la résilience face au stress et à réduire le risque face à l'émergence de symptômes psychopathologiques liés au stress.



## ACKNOWLEDGEMENTS

---

Five years have passed since I started my PhD journey. When I look back, I feel a deep sense of gratitude for having been given the opportunity to live this wonderful adventure that enriched me immensely and made me grow up, as an aspiring researcher, as a teacher, and foremost as a person. I'm very thankful to wake up every day to work on a topic that fascinates me in a friendly and stimulating professional environment. Like the steep paths leading from Calenzana to Conca, this track was sometimes hard and challenging of course. But above all, what I will keep in me from this journey is the extraordinary people who I encountered along the way and who made the completion of this thesis possible. Many thanks to all of you for your support, your advices, and the invaluable moments and discussions that we shared. You made and still make my life so precious.

First of all, I would like to express my deep gratitude to my thesis supervisor Prof. Dr. Chantal Martin Soelch for giving me the opportunity to do a PhD in her research team on this fascinating topic. Thank you sincerely, Chantal, for encouraging me to explore the questions that interested me at most, for enabling me to go where my curiosity was guiding me, for allowing me to learn and deepen my knowledges as far as I wished, and for pushing me to outperform myself when I thought that I wouldn't be able to reach the summit. Thank you for your encouragements, for your insightful advices and comments that made me evolve as a research scientist. I'm also tremendously thankful for the opportunity you gave me to carry out a research stay at the National Institutes of Mental Health (NIMH) in Bethesda. Thank you above all for valuing my work and my ideas, and for believing in me as a research scientist.

I am profoundly grateful to Dr. med. Monique Ernst for her hearty and generous welcoming at the Section on Neurobiology of Fear and Anxiety at the NIMH. Thank you so much, Monique, for the enthusiasm for research that you instigate, for your kindness, for your caring support and encouragements, and for the countless things I could learn from you. You inspire me to improve myself, to strive for scientific rigor and for critical thinking.

My sincere thanks also go to Prof. Dr. Dominik Schoebi for his generous support, his wise guidance, and for taking the time to discuss with me various statistical models, and to help me identify the best fitted for analysing the cortisol measurements. Thanks a lot, Dominik, for your generous availability. I broadened and deepened significantly my knowledge and skills in multilevel modeling thanks to you.

Further, I would like to thank warmly my co-authors for their continuous guidance, advices and suggestions. Thanks a lot Dr. med. Monique Ernst, Dr. Andrea Federspiel, Matthias Guillod, Prof. Dr. med. Gregor Hasler, Prof. Dr. med. Philipp Homan, Prof. Dr. Antje Horsch, Prof. Dr. Chantal Martin Soelch, Dr. med. Christoph Mueller-Pfeiffer, Xinyi Ouyang, Romina E. Recabarren, Prof. Dr. Dominik Schoebi, Dr. Salvatore Torrisi, and Prof. Dr. med. Roland Wiest. I learnt a lot thanks to the expertise and the practical experience you kindly shared with me.

My sincere thanks go to my examiners, Prof. Dr. Chantal Martin Soelch, Prof. Dr. med. Gregor Hasler, and P.D. Dr. med. Petra Schweinhardt, PhD for their precious time. Their constructive and insightful comments were decisive for improving my work. I also thank a lot the members of my examination committee, Prof. Dr. Roberto Caldara, Prof. Dr. Bernadette Charlier, and Prof. Dr. Dominik Schoebi. I feel very privileged and grateful to have you in my examination committee.

My deep and heartfelt thanks go to all my colleagues at the IReach Lab and at the Department of Psychology. I am deeply grateful for having been given the chance of sharing these five years with you in such a caring, motivating and friendly working environment. I feel very lucky to have been so well surrounded and to collaborate with such wonderful and dedicated people. A very special thank goes first to my office mate and friend Matthias Guillod with whom I had the privilege of sharing this PhD journey over all these years. Thanks for your precious support and for our memorable scientific and more philosophico-existential discussions. I also express my sincere thanks to all the people at the Department of Psychology who made this PhD track so enriching and unforgettable. This academic journey would not have been the same without all of you. A special thank goes to Marlène Abadie, Christophe Fitamen, Pascal Gygax, Regina Jensen, Katharina Ledermann, Nathalie Meuwly, Dany Nkonlack, Anne-Laure Oftinger, Benoît Perriard, Mayron Piccolo, Romina E. Recabarren, Anne-Raphaëlle Richoz, Marianne Richter, Fiona Rosselet, Philippe Schneider, Tanya Tandon, and Pascal Wagner-Egger for our motivating and encouraging discussions, awesome hikes, bike tours, concerts, meditation week, and lunchtimes full of humor, lightness and friendliness. This PhD journey would certainly not have been as enjoyable without our famous Hike-for-Life, source of epic memories. Thanks a lot to Pascal Gygax for the fun we had organizing it. I would like to extend my thanks to Dorothée Aebischer, Eric Bourquard, Ian Law, Laurence Pitton, Thierry Progin, Chantal Rodriguez, Esther Stauffacher, and Claudia Vonlanthen for their constant support and help with administrative questions and antagonistic computers.

I further express my sincere thanks to all the people and colleagues I was lucky to meet and to work with during my research stay at the NIMH. A special thank goes to Salvatore (Sam) Torrisi for his time, his precious help and teaching guidance with learning and running fMRI analyses with AFNI in such a welcoming and caring working atmosphere. I owe you so much. I'm also very grateful to Brenda Benson, Nicholas (Nick) Balderston, Adam Gorka, and Richard (Rick) Reynolds for their time in providing me their expertise and helpful suggestions in fMRI analyses. Likewise, I warmly thank Anita Harrewijn for her kind support, for sharing daily conversations and laughs, baseball games, visits, and concerts that made my time at the NIMH so great.

The project in which this PhD thesis is embedded would not have been carried out without the support and contribution of the Research Pool of the University of Fribourg [no. 578] and of the Gottfried und Julia Bangerter-Rhyner-Stiftung [no. 8472]. I thank these institutions for making this work possible. Many thanks also to the Swiss National Science Foundation (SNSF) for having supported my Doc.Mobility [n° P1FRP1\_174818] at the National Institutes of Mental Health (NIMH), Bethesda, USA.



Thanks to the team of the Department of Diagnostic and Interventional Neuroradiology of the University Hospital of Bern who supported the MRI data collection for this PhD thesis. Also, I extend my gratitude to all the participants involved in our project for contributing to the experimental works presented in this thesis and who made this PhD thesis possible.

I also thank my Bachelor, Master and intern students at the University of Fribourg for their motivating and challenging questions, which taught me many things and allowed me to get better. Thanks to Valérie Brunisholz, Laura Cardoso, Helena Chapuis, Mélanie El-Khoury, Debora de Felice, Laryssa Grosjean, Marjolaine Guillet, Marie-Josée Meuwly, Benjamin Nunez, Céline Rappaz, Mireille Régis, Sandra Ribeiro, Marc Rothlisberger, Aurélie Schneider, Danilo Tuzzolino, and Morgane Vouillamoz. A special thank goes to Céline, Morgane, and Sandra for their continuous help and commitment.

A warm and grateful thank to Madeleine Viviani for reading my PhD thesis. Thanks a lot, Madeleine, for your precious and relevant comments that helped me to improve significantly the writing quality of my work.

I feel particularly lucky and deeply grateful to be surrounded by friends who are extremely dear to me. Very special warm thanks go to Jannick and Andrea Carretoni, Xavier Conus, Stéphanie Haymoz, Pierre Köstinger, Colette Niclasse, and Lea Oberholzer for your invaluable emotional support, for the beautiful and inspiring persons you are, for being here and contributing to make my life so beautiful, rich, and shining. I'm the luckiest person to have you in my life. Also, I would like to thank Marie Lambert for our inspiring discussions, which helped me in determinant moments along this PhD track. A special thank you to Stéphanie Reynaud for her heartening support and inspiring strength she gave me at the right times to keep me striving towards and reaching my objective.

Last but not least, I would like to express my deep and great gratitude to my parents, Laurence and Alain. You always believed in me and encouraged me when I doubted to be able to reach a new summit that seemed so ambitious and unattainable to me. Thanks so much for your love, your support, your trust. You inspire me to do my best, but above all to believe in myself and in my dreams. My warm thanks go also to my grand parents Jacqueline and Jeannot, and to my entire family for their continuous support, their presence, their attentions, their love. I am deeply grateful and I feel extremely lucky to have you in my life.



“ Two roads diverged in a yellow wood,  
And sorry I could not travel both  
And be one traveler, long I stood  
And looked down one as far as I could  
To where it bent in the undergrowth;

Then took the other, as just as fair,  
And having perhaps the better claim,  
Because it was grassy and wanted wear;  
Though as for that the passing there  
Had worn them really about the same,

And both that morning equally lay  
In leaves no step had trodden black.  
Oh, I kept the first for another day !  
Yet knowing how way leads on to way,  
I doubted if I should ever come back.

I shall be telling this with a sigh  
Somewhere ages and ages hence :  
Two roads diverged in a wood, and I -  
I took the one less traveled by,  
And that has made all the difference. ”

Robert Frost, *The road not taken*



# TABLE OF CONTENTS

---

Abstract	v
Résumé	vii
Acknowledgements	xi
Table of contents	xvii
List of figures	xxiii
List of tables	xxv
List of acronyms	xxvii
<b>CHAPTER 1 - INTRODUCTION</b>	<b>1</b>
<b>CHAPTER 2 - THEORETICAL BACKGROUND</b>	<b>5</b>
2.1 Reward processing in humans	6
2.1.1 Definition and functions of reward	6
2.1.1.1 Learning component of reward	6
2.1.1.2 Motivational component of reward	8
2.1.1.3 Affective component of reward	10
2.1.1.3.1 Hedonic responses, a result of instrumental learning	11
2.1.1.3.2 Reward processing, a special case of emotional processing ?	11
2.1.1.3.3 How does emotion regulation contribute to reward reactivity ?	12
2.1.2 Experimental tasks to study reward processing	15
2.1.2.1 Passive reward tasks	15
2.1.2.2 Instrumental-reward tasks	16
2.1.2.3 Decision-making tasks	17
2.1.3 Reward processing in the brain	18
2.1.3.1 Neuroanatomy of the reward circuitry	19
2.1.3.2 Neurochemical reward systems	21
2.1.3.2.1 Role of midbrain dopamine neurons in the learning component of reward	22
2.1.3.2.2 Role of midbrain dopamine neurons in the motivational component of reward	23
2.1.3.2.3 Role of endocannabinoid and opioid receptors in the affective component of reward	25
2.1.3.3 Neural correlates of reward processing in humans	27
2.1.3.3.1 Reward reactivity during anticipation : the motivational impact of rewards	30
2.1.3.3.2 Reward reactivity during delivery : the hedonic impact of rewards	33
2.1.4 Summary	37
2.2 Factors affecting reward processing : focus on stress and cognitive effort	39
2.2.1 Effects of stress exposure	39
2.2.1.1 Stress, stressor and psychological reactions to stressors	39
2.2.1.1.1 Rationale to focus on unpredictable and uncontrollable acute stress	40
2.2.1.2 Experimental procedures to induce acute stress	41
2.2.1.2.1 Measures of experimental stress induction	42
2.2.1.3 Stress processing in the brain and neuroendocrine reactions to stress exposure	43
2.2.1.4 Behavioral and neural effects of acute stress on reward processing	46
2.2.2 Effects of cognitive effort	51
2.2.2.1 Rationale to focus on working memory effort	51
2.2.2.2 Behavioral and neural effects of cognitive effort on reward processing	53
2.2.2.2.1 Effort-discounting effect on motivation	53
2.2.2.2.2 The paradox of effort motivation to work harder : enhancing effect of cognitive effort	54

2.2.2.3	How is cognitive effort affected by reward and stress ?	55
2.3	Reward processing under stress and cognitive load : clinical implications for the vulnerability to major depression	57
2.3.1	Impaired reward processing : when rewards do not reward anymore	58
2.3.2	Stress exposure and impaired stress sensitivity as precipitants	60
2.3.2.1	Exposure to stressful life events	60
2.3.2.1.1	Linking stressful life events to depression, an unidirectional relationship ?	61
2.3.2.2	Heightened sensitivity to stress in major depression	62
2.3.3	Interaction between the reward and stress systems	63
2.3.4	Cognitive impairments	64
2.3.5	Summary of the theoretical background	66
<b>CHAPTER 3 - AIMS AND HYPOTHESES</b>		<b>69</b>
3.1	Empirical work I	72
3.2	Empirical work II	73
3.3	Empirical work III	74
<b>CHAPTER 4 - METHODS</b>		<b>77</b>
4.1	Participants	78
4.1.1	Recruitment	78
4.1.2	Inclusion and exclusion criteria	79
4.2	Study design	81
4.3	Procedure	81
4.4	Measures	83
4.4.1	Clinical interviews	83
4.4.2	Self-reported questionnaires	83
4.4.2.1	Socioeconomic status	83
4.4.2.2	Handedness	84
4.4.2.3	Depressive symptoms	84
4.4.2.4	Cognitive emotion regulation strategies	84
4.4.3	Fribourg reward task	85
4.4.4	Acute experimental stress induction	87
4.4.5	Magnetic resonance imaging	88
4.4.5.1	Task-based functional magnetic resonance imaging	89
4.4.5.2	T1-weighted images	89
4.5	Data analyses	90
4.5.1	Behavioral data analyses	90
4.5.1.1	Working memory performance during the Fribourg reward task	90
4.5.1.2	Self-reported mood and stress ratings during the Fribourg reward task	90
4.5.2	fMRI data analysis	91
4.5.2.1	fMRI data preprocessing	91
4.5.2.2	fMRI data analysis	91
4.5.3	Correlation analyses between reward-related neural activation and self-reported measures of emotion regulation and depressive symptoms	93
4.6	Additional data analyses	94
4.6.1	Statistical analyses	95
4.7	Ethics	97

<b>CHAPTER 5 - EMPIRICAL WORK I</b>	<b>99</b>
5.1 Abstract	100
5.2 Introduction	101
5.3 Materials and Methods	104
5.3.1 Participants	104
5.3.2 General procedure	104
5.3.3 Fribourg reward task	104
5.3.4 Acute experimental stress manipulation	106
5.3.5 Self-reported ratings of the experimental stressor manipulation	106
5.3.6 MR data acquisition	106
5.3.7 Analyses of working memory performance	107
5.3.8 Analyses of the acute experimental stressor effect on self-reported ratings	107
5.3.9 fMRI data analysis	107
5.3.9.1 fMRI data preprocessing	107
5.3.9.2 fMRI data analysis	108
5.4 Results	109
5.4.1 Effect of acute experimental stressor on self-reported ratings	109
5.4.2 Working memory performance	110
5.4.2.1 Response accuracy	110
5.4.2.2 Reaction times (RT)	110
5.4.3 fMRI results	111
5.4.3.1 Striatal activations during reward anticipation	111
5.4.3.2 Striatal activations during feedback delivery	114
5.5 Discussion	117
5.6 Acknowledgements	120
5.7 Funding	120
5.8 Declaration of interest	120
<b>CHAPTER 6 - EMPIRICAL WORK II</b>	<b>121</b>
6.1 Abstract	122
6.2 Introduction	124
6.3 Materials and Methods	126
6.3.1 Participants	126
6.3.2 General procedure	127
6.3.3 Self-reported psychological measurements	127
6.3.3.1 Beck Depressive Inventory II (BDI-II)	127
6.3.3.2 Cognitive Emotion Regulation Questionnaire (CERQ)	128
6.3.4 Fribourg reward task	128
6.3.5 MR data acquisition	130
6.3.6 fMRI data analysis	131
6.3.6.1 Task-based fMRI data preprocessing	131
6.3.6.2 Task-based fMRI data analysis	131
6.3.7 Correlation between reward-related NAcc activity and emotion regulation	132
6.3.8 Correlation between reward-related NAcc activity and depressive symptoms	132
6.3.9 Correlation between emotion regulation and depressive symptoms	133

6.4	Results	134
6.4.1	Correlation between reward-related NAcc activity and emotion regulation	134
6.4.2	Correlation between reward-related NAcc activity and depressive symptoms	134
6.4.3	Correlation between emotion regulation and depressive symptoms	134
6.5	Discussion	136
6.6	Acknowledgements	138
6.7	Funding	138
6.8	Declaration of interest	138
<b>CHAPTER 7 - EMPIRICAL WORK III</b>		<b>139</b>
7.1	Abstract	140
7.2	Introduction	142
7.3	Methods and Material	145
7.3.1	Participants	145
7.3.2	General procedure	148
7.3.3	Fribourg reward task	148
7.3.4	Experimental stress induction	150
7.3.5	Effect of the experimental acute stressor on self-reported mood	150
7.3.6	MR data acquisition	150
7.3.7	Behavioral data analyses	151
7.3.7.1	Working memory performance	151
7.3.7.2	Self-reported mood ratings during the Fribourg reward task	151
7.3.8	fMRI data analysis	151
7.3.8.1	Task-based fMRI data preprocessing	151
7.3.8.2	Task-based fMRI data analysis	152
7.4	Results	153
7.4.1	Behavioral results	153
7.4.1.1	Working memory performance: response accuracy	153
7.4.1.2	Working memory performance: reaction times (RT)	153
7.4.1.3	Self-reported mood ratings during the Fribourg reward task	154
7.4.2	fMRI results	155
7.4.2.1	Striatal activations during anticipation	155
7.4.2.2	Striatal activations during delivery	158
7.5	Discussion	163
7.5.1	Group differences in striatal reactivity	164
7.5.2	Stress-induced effect in striatal regions	165
7.5.3	Modulation of the striatal responses by cognitive load	165
7.5.4	Limitations	166
7.5.5	Conclusion	166
7.6	Acknowledgements	167
7.7	Funding	167
7.8	Declaration of interest	167



<b>CHAPTER 8 - ADDITIONAL DATA ANALYSES</b>	<b>169</b>
8.1 Background	171
8.2 Effects of the experimental stressor on cortisol responses in healthy individuals (Empirical work I)	173
8.3 Differential effects of the experimental stressor on cortisol responses in healthy individuals without and with increased familial vulnerability to major depression (Empirical work III)	176
<b>CHAPTER 9 - GENERAL DISCUSSION</b>	<b>179</b>
9.1 Summary of findings	181
9.1.1 Effect of stress exposure on reward processing in healthy adults, and the modulatory role of cognitive load	181
9.1.2 Relationship between the emotion regulation and the responsiveness to reward delivery in healthy adults, and their link to depressive symptoms	183
9.1.3 Differential effects of stress exposure on reward processing between healthy control and healthy vulnerable individuals, and the modulatory role of cognitive load	184
9.2 Integrated discussion of findings	186
9.2.1 Effect of stress exposure on striatal reactivity : insights on potential vulnerability markers for the development of compulsive automatized behaviors	186
9.2.1.1 Stress-induced heightened arousal in the dorsal striatum	186
9.2.1.2 Stress-induced sensitization of reward reactivity in the dorsal striatum	188
9.2.2 Impaired reward responsiveness following higher cognitive effort	190
9.2.3 Implications of maladaptive emotion regulation in hedonic responsiveness	192
9.2.4 Insights on potential vulnerability markers in vulnerable individuals for major depression	194
9.3 Limitations and methodological considerations	198
9.3.1 Small sample size	198
9.3.2 Characteristics of the healthy vulnerable sample	199
9.3.3 Design of the study and experimental task	199
9.3.4 Failure to evidence stress-induced reactivity of the HPA system	200
9.4 Future directions	202
<b>CHAPTER 10 - CONCLUSION</b>	<b>207</b>
References	211
Appendix	243
A. Empirical work I – Supplemental results	243
A.1 Significant whole-brain activations during the anticipation phase	243
A.2 Significant whole-brain activations during the delivery phase	245
B. Empirical work III – Supplemental results	248
B.1 Significant whole-brain activations during the anticipation phase	248
B.2 Significant whole-brain activations during the delivery phase	250
C. Project documents	253
C.1 Participant information intended for healthy control participants	253
C.2 Participant information intended for healthy vulnerable participants	255
C.3 Magnetic resonance imaging security questionnaire	257
C.4 Ethics approval	259
Curriculum Vitae	263
List of publications	269



## LIST OF FIGURES

---

- Figure 2.1 Relationships linking the learning, motivational, and affective components, and their functions in reward processing.
- Figure 2.2 Illustration of a version of the slot-machine task, a passive reward task.
- Figure 2.3 Illustration of a version of the Monetary Incentive Delay (MID) task.
- Figure 2.4 Illustration of a version of the Wheel of Fortune (WOF) task.
- Figure 2.5 Illustration of the main afferent (input) and efferent (output) connections of the striatum.
- Figure 2.6 Illustration of the main projections of the midbrain dopamine (DA) neurons located in the substantia nigra pars compacta (SNc) and in the ventral tegmental area (VTA).
- Figure 2.7 Illustration of the neural correlates involved during both the reward anticipation and the reward delivery based on meta-analyses in humans.
- Figure 2.8 Illustration of the biological and neural systems involved in the stress reaction characterizing the psychological responses of fear and anxiety.
- Figure 2.9 Biphasic-reciprocal model of reallocation of neural resources during the exposure to an acute stressor.
- Figure 2.10 Spatial delayed response task with multiple working memory (WM) loads (Glahn et al., 2002).
- Figure 4.1 Process for recruiting participants and participants' allocation for each empirical work.
- Figure 4.2 Illustration of measurements collected in all participants.
- Figure 4.3 Fribourg reward task.
- Figure 4.4 Salivary cortisol sampling during the Fribourg reward task.
- Figure 5.1 Illustration of (a) a non-rewarded trial at the highest level of working memory load and (b) a rewarded trial at the easiest working memory load of the Fribourg reward task.
- Figure 5.2 Effect of the stress condition on subjective mood and stress ratings during the Fribourg reward task.
- Figure 5.3 Working memory performance during the Fribourg reward task.
- Figure 5.4 Illustration of the main effect of reward during the anticipation phase.
- Figure 5.5 Illustration of the main effect of stress and the twofold interaction effect (reward  $\times$  load) during the delivery phase.
- Figure 6.1 Illustration of two trials of the Fribourg reward task.

- Figure 6.2 Illustration of the significant associations between nucleus accumbens (NAcc) responsiveness to reward delivery and both, the propensity to use maladaptive emotion regulation strategies and subclinical depressive symptoms in healthy adults.
- Figure 7.1 Illustration of the Fribourg reward task.
- Figure 7.2 Effect of stress induction and reward on the working memory performance and self-reported mood ratings during the Fribourg reward task.
- Figure 7.3 Illustration of the main effect of group comparing the healthy adults without (HC, healthy control) and with (HV, healthy vulnerable) increased risk for major depression, and threefold interaction effect (group  $\times$  stress  $\times$  load) during the anticipation phase.
- Figure 7.4 Illustration of the main effect of reward and the twofold interaction effect (stress  $\times$  reward) that occurred during the anticipation phase in the healthy adults without (HC, healthy control) and with (HV, healthy vulnerable) increased risk for major depression.
- Figure 7.5 Illustration of the main effect of stress in the healthy adults without (HC, healthy control) and with (HV, healthy vulnerable) increased risk for major depression, and twofold interaction effect (group  $\times$  load) during the delivery phase.
- Figure 8.1 Illustration of (A) the hypothesis related to the evolution of the salivary cortisol concentration observed in 16 healthy adults, and (B) their salivary cortisol concentration during the Fribourg reward task.
- Figure 8.2 Illustration of (A) the hypothesis related to the evolution of the cortisol concentration observed in 10 healthy adults without (HC, healthy control) and 12 healthy adults with (HV, healthy vulnerable) increased risk for major depression, and (B) their cortisol concentration during the Fribourg reward task.
- Figure 9.1 Illustration of the reward-related mechanisms proposed in this thesis being involved under unpredictable acute stress exposure during the anticipation and delivery phases in healthy adults, and how cognitive demands and cognitive emotion regulation strategies further modulate reward responsiveness during the delivery phase.
- Figure 9.2 Illustration of the potential vulnerability markers for major depression disorder (MDD) proposed in the light of our third empirical work.

## LIST OF TABLES

---

Table 2.1	Meta-analytic reports of the neural correlates implicated in the reward processing during the anticipation and the delivery of rewards in healthy humans
Table 2.2	Neural correlates implicated in the processing of reward magnitude during the anticipation and delivery of rewards
Table 2.3	Neural correlates implicated during the delivery of monetary, food, and erotic rewards reported in the meta-analysis of Sescousse et al. (2013) on 87 fMRI studies
Table 2.4	Overview of studies documenting the effects of stress on the reward processing in healthy adults
Table 4.1	Participants' characteristics, and scores on questionnaires evaluating depressive symptoms and emotion regulation strategies
Table 5.1	Main and interaction effects of within-subject contrasts in the bilateral nucleus accumbens (NAcc), caudate nucleus, and putamen
Table 5.2	Significant whole-brain clusters (cluster-size corrected) for (1) the main effect of reward (rewarded vs not-rewarded) during the anticipation phase, and (2) the main effect of stress (stress vs control), as well as interaction effect between reward (rewarded vs not-rewarded) and working memory (WM) load (high vs low) during the delivery phase
Table 6.1	Socio-demographic and psychological description of the sample ( $N = 23$ , 14 females), parameter estimate's mean of the neural activation in the nucleus accumbens characterizing reward responsiveness to reward delivery, and normality test of the variables (Kolmogorov-Smirnov)
Table 7.1	Group demographics and psychological measures of depressive symptoms
Table 7.2	Main and interaction effects for the within- and between-subject contrasts in the bilateral nucleus accumbens (NAcc), caudate nucleus, and putamen
Table 7.3	Significant whole-brain clusters (cluster-size corrected) for the main and interaction effects of interest during the (1) anticipation phase and (2) delivery phase in healthy control (HC) and healthy vulnerable (HV) individuals
Table 8.1	Cortisol (log) response during the Fribourg reward task in 16 healthy adults
Table 8.2	Comparison of the cortisol (log) response during the Fribourg reward task in 10 healthy control (HC) and 12 healthy vulnerable (HV) adults
Table A.1	Significant whole-brain clusters (cluster-size corrected) for the main effects of stress, reward, and working memory (WM) load, as well as their interactions during the anticipation phase

- Table A.2 Significant whole-brain clusters (cluster-size corrected) for the main effects of stress, reward, and working memory (WM) load, as well as their interactions during the delivery phase
- Table B.1 Significant whole-brain clusters (cluster-size corrected) for the main between-subject effect of group (healthy control vs healthy vulnerable individuals), and the main within-subject effects of stress (stress vs control), reward (rewarded vs not-rewarded), and working memory (WM) load (high vs low), as well as their interactions during the anticipation phase
- Table B.2 Significant whole-brain clusters (cluster-size corrected) for the main between-subject effect of group (healthy control vs healthy vulnerable individuals), and the main within-subject effects of stress (stress vs control), reward (rewarded vs not-rewarded), and working memory (WM) load (high vs low), as well as their interactions during the delivery phase

## LIST OF ACRONYMS

---

ACC	Anterior Cingulate Cortex
ACTH	AdrenoCorticoTropic Hormone
AFNI	Analysis of Functional NeuroImages
ANOVA	Analysis Of VAriance
ANS	Autonomic Nervous System
ACF	AutoCorrelation Function
AVP	Arginine VasoPressin
BDI-II	Beck Depressive Inventory II
BOLD	Blood-Oxygen-Level-Dependent
CERQ	Cognitive Emotion Regulation Questionnaire
CNS	Central Nervous System
CO <sub>2</sub>	Carbone diOxyde
CPT	Cold-Pressor Test
CRH	Corticotrophin Releasing Hormone
CR	Conditioned Response
CS	Conditioned Stimulus
DA	DopAmine
DAergic	DopAminergic
dACC	dorsal Anterior Cingulate Cortex
dIPFC	dorsolateral PreFrontal Cortex
dmPFC	dorsomedial PreFrontal Cortex
DSM-IV-TR	Diagnostic and Statistical Manual of Mental Disorders, fourth edition
EHI	Edinburgh Handedness Inventory
EPI	Echo-Planar Imaging
FIGS	Family Interview for Genetic Studies

fMRI	functional Magnetic Resonance Imaging
FOV	Field-Of-View
GML	General Linear Model
HC	Healthy Control
HV	Healthy Vulnerable individuals at increased risk for major depression disorder
HPA	Hypothalamic-Pituitary-Adrenal
HRF	Haemodynamic Response Function
IC	Individu Contrôle
IPSE	Indice de Position SocioEconomique (i.e. index of economic status position)
IV	Individu Vulnérable
MADRS	Montgomery and Asberg Depression Rating Scale
MAST	Maastricht Acute Stress Test
MDD	Major Depression Disorder
MID	Monetary Incentive Delay
MINI	Mini-International Neuropsychiatric Interview
MIST	Montreal Imaging Stress Task
MMST	Mannheim Multicomponent Stress Test
MNI	Montreal Neurological Institute
mPFC	medial PreFrontal Cortex
MPRAGE	Magnetization Prepared Rapid Acquisition Gradient Echo
MR	Magnetic Resonance
MRI	Magnetic Resonance Imaging
NAcc	Nucleus Accumbens
NS	Neutral Stimulus
OFC	OrbitoFrontal Cortex
PE	Prediction Error
PFC	PreFrontal Cortex



PVN	ParaVentricular Nucleus
RDoC	Research Domain Criteria
ROI	Region-Of-Interest
RT	Reaction Time
SAM	Sympatho-AdrenoMedullary system
SMA	Supplementary Motor Area
SNc	Substantia Nigra pars compacta
SFG	Superior Frontal Gyrus
SPSS	Statistical Package for the Social Sciences
TE	Echo Time
TDC	Trouble Dépressif Caractérisé
TR	Repetition Time
TSSST	Trier Social Stress Test
UR	Unconditioned Response
US	Unconditioned Stimulus
vIPFC	ventrolateral PreFrontal Cortex
vmPFC	ventromedial PreFrontal Cortex
VTA	Ventral Tegmental Area
WM	Working Memory
WOF	Wheel Of Fortune



# CHAPTER 1

## INTRODUCTION

---

# INTRODUCTION

---

In human and animal, the ability to detect and value potential rewards in the environment is fundamental for fulfilling basic needs including food, water, sex and social interactions (Haber & Knutson, 2010). Defined as the energizing behavior, motivation is driven by the pursuit of rewards and the avoidance of danger or punishments (Ernst, 2014; O'Doherty, 2004b). Understanding how humans handle the pursuit of these goals and why motivational processes promoting survival and well-being get disrupted under some circumstances is meaningful since impaired motivation is at the core of many mental disorders. Impaired motivation involves apathy and anhedonia, i.e. the inability to engage in goal-driven behaviors or to experience hedonic feelings from positive stimuli, as evidenced in affective disorders (e.g. Kerestes, Davey, Stephanou, Whittle, & Harrison, 2014; S. J. Russo & Nestler, 2013) or, in contrast, excessive and harmful behaviors which characterize for instance addictions (Everitt & Robbins, 2013; Koob, 2013; Koob & Le Moal, 2008; Koob & Volkow, 2010). The development of relevant treatments and preventive interventions for motivation-related disorders has been given high priority in the Research Domain Criteria (RDoC) initiative (National Institute of Mental Health, 2009). This development calls for a better understanding of what generates motivation and how motivational processes are dynamically regulated in healthy individuals, of the risk factors that contribute to disrupting these processes, and of what characterizes motivational processes in vulnerable individuals. The faculty to engage in motivated behaviors and to experience pleasure relies on an interconnected cortico-basal ganglia circuit which is at the heart of the reward system (Haber & Knutson, 2010). Stress acts as a major precipitant of psychopathological disorders, notably by disrupting the reward system leading to impaired motivational and hedonic processes (Cabib & Puglisi-Allegra, 2012; Chrousos, 2009; Dillon et al., 2014; Novick et al., 2018). While the reward system promotes approach behaviors, the stress system is tightly linked to the fear circuitry which fosters avoidance and sustains the processing of aversive and negative emotions (Ernst, Torrissi, Balderston, Grillon, & Hale, 2015; Richards, Plate, & Ernst, 2013). In daily life, the coordination of both systems is critical for adaptive goal-oriented behaviors resulting in approach towards beneficial rewards or in avoidance of danger and harmful events (Fareri & Tottenham, 2016). Therefore, how the reward and stress systems interact for regulating behaviors, cognition and emotional states is pivotal for promoting well-being. Nevertheless, emerging data exploring how individuals process rewards and

threats, and how this valuation influences motivation and pleasure shows inconsistencies, suggesting extensive individual variability together with the influence of additional factors (Paulus, 2017). Among potential explanatory factors, higher-order cognitive functions might importantly contribute to the functional processes at the interplay between the reward and stress systems through a top-down cognitive regulation of these systems anchored in subcortical structures (Ernst, 2014; Heatherton & Wagner, 2011; Ray & Zald, 2012). Specifically, this top-down cognitive control mechanism has been related to emotion regulation processes (Quirk & Beer, 2006). Among mental conditions characterized by strong dysfunctions of the reward and stress systems together with impaired cognitive processes and emotion regulation, Major Depression Disorder (MDD) is one of the most debilitating and burdensome mental illness whose onset, development and recurrence are crucially rooted in alterations of the reward, stress, and regulatory systems (Bogdan, Nikolova, & Pizzagalli, 2013; Bromet et al., 2011). Anhedonia combined with the loss of motivation are cardinal symptoms of MDD (American Psychiatric Association, 2013). These core symptoms are thought to be induced by blunted reward responsiveness (Der-Avakian & Markou, 2012), and are central vulnerability markers of depression as evidenced for instance in first-degree relatives of parents with a history of major depression (W. Liu et al., 2016). Together with a disrupted reward system, stressful life events have been strongly implicated in the onset of a first depressive episode, symptoms' maintenance and depressive relapse (Buckman et al., 2018; R. T. Liu & Alloy, 2010). Stressful life events might strengthen the vulnerability to MDD, particularly in individuals with increased stress sensitivity reflected notably by a hyperactivation of the hypothalamic-pituitary-adrenal (HPA) system (Bogdan et al., 2013; Hasler, Drevets, Manji, & Charney, 2004; Hasler & Northoff, 2011). Taken together, blunted reward responsiveness and increased stress sensitivity constitute two promising vulnerability factors implicated in the etiology of MDD (Pizzagalli, 2014). However, little is known so far about how the reward and stress systems might interact in healthy adults, in MDD patients and in individuals at increased familial risk for MDD. Among potential risk factors that might contribute to precipitate depressive symptoms, both impaired higher-order cognitive functions and maladaptive emotion regulation strategies emerge consistently in the literature (Rive et al., 2013; Snyder, 2013).

In this framework, the **first aim** of this thesis was to explore how stress exposure influences the basic neural mechanisms of reward processing in healthy adults, with the intention of yielding new insights on the vulnerability factors implicated in the onset of stress-related psychopathologies. The **second aim** of this thesis was to investigate how cognitive effort manipulated by variable levels of cognitive load might contribute to modulate the effects of stress exposure on the basic neural mechanisms of reward processing in healthy adults. Studying how the normal reward

function is altered by stress exposure and various levels of cognitive load implicated in the availability of regulatory processes might help to build up a better understanding of the etiology and development of complex stress-related disorders characterized by impaired reward processing. Since anhedonia is intrinsically related to an impaired ability to experience positive and hedonic emotions, the **third aim** of this thesis consisted in exploring whether the propensity of healthy adults to use adaptive or maladaptive emotion regulation strategies is associated with the neural responsiveness to reward delivery, a measure of hedonic reactivity to reward. Finally, the **fourth aim** of this thesis was to use the vulnerability to depression as a clinical model to test the implications of stress exposure on the neural mechanisms of reward processing as risk factor for the development of anhedonic symptoms. Specifically, we aimed at investigating whether the effect of stress exposure on reward processing might differentiate between healthy adults without and with increased familial vulnerability to depression. In an exploratory way, we examined whether variable levels of cognitive effort modulate the effect of stress exposure on reward processing in a different manner in healthy adults without and with increased familial vulnerability to depression. The first and second aims were addressed in *Empirical work I*, the third aim in *Empirical work II*, and the fourth aim in *Empirical work III*.

With the aim to answer these questions, the present thesis is structured into nine chapters including the present introduction (**Chapter 1**). **Chapter 2** provides an overview of the current literature investigating the reward system in the human brain, how this system is affected under acute stress and under cognitive effort in healthy humans. As major MDD is strongly related to an imbalance between the reward and the stress systems, we discuss in the last section the clinical implications of a dysfunction in reward responsiveness and in stress reactivity, and of cognitive impairments as potential risk factors for MDD. **Chapter 3** introduces the aims and hypotheses of the three empirical works carried out for this thesis, while **Chapter 4** delineates the general methods applied to answer the questions raised in the thesis. The next three chapters (**Chapter 5, 6, and 7**) are devoted to the three empirical transversal studies and their results, with **Chapter 8** presenting some additional data exploration. **Chapter 9** provides a summary of the main findings demonstrated in the three empirical works with a general discussion of their implications, limitations, new opened avenues and future perspectives. The last chapter (**Chapter 10**) offers a general conclusion to this PhD thesis.

# CHAPTER 2

## THEORETICAL BACKGROUND

---

# THEORETICAL BACKGROUND

---

## 2.1 REWARD PROCESSING IN HUMANS

### 2.1.1 Definition and functions of reward

One of the most essential functions of reward processing is to promote adaptive behaviors that maximize beneficial positive outcomes such as rewards and that minimize detrimental negative consequences for the organism (Balleine & Gottfried, 2011; Lutz & Widmer, 2014). In everyday life, a reward describes any event or object that is able to produce a positive or a pleasurable experience (White, 2011). The modern scientific conceptualization of reward finds its roots in the Law of Effect formulated by Thorndike one century ago (Marks, 2011). In Thorndike's theory, a reward is nothing else than a positive reinforcer which acts to increase the relationship between the environment (i.e. stimulus) and the instrumental response (i.e. behavior) that is executed in order to obtain the reward (Thorndike, 1911, 1927). Early motivation and learning theories conceived positive reinforcers as events or stimuli able to promote (i) an internal drive to satisfy biological or psychological needs and to regulate homeostatic processes (Hull, 1943), (ii) memory consolidation (e.g. of the stimuli association) (Pfaff, 1969), and (iii) motivational effects resulting in motivated behaviors which end with the delivery of the positive reinforcer such as for instance palatable food (Skinner, 1938). In the nineties, the incentive salience hypothesis formulated by Berridge and Robinson (1998) stipulated that the processing of reward consists in three distinct components: (i) the motivation to work for a reward (wanting component), (ii) the hedonic reaction to the reward delivery (liking component), and (iii) a learning component (K. C. Berridge, Robinson, & Aldridge, 2009). Here after, we describe how the concept of reward builds on the learning component, the motivational component, and the affective component of reward, seen as three functions.

#### 2.1.1.1 Learning component of reward

According to learning theories, the concept of reward refers to a type of positive reinforcement that is able to increase the probability of the occurrence of a behavior when the



reward delivery is contingent to and in temporal proximity with the behavior (Everitt & Robbins, 2013; White, 2011). Both primary and secondary rewards might act as positive reinforcers. The distinction between primary and secondary rewards comes within a form of associative learning also referred to as classical or Pavlovian conditioning. During the classical/Pavlovian conditioning, a neutral stimulus (NS) (e.g. a sound, a light) is presented in close temporal proximity with an unconditioned stimulus (US) (e.g. food placed in the mouth). The US has an intrinsic incentive value (positive or aversive) that triggers an unconditioned response (UR). Once associated with a US, the NS becomes a conditioned stimulus (CS) whose occurrence gives rise to the same reaction as the one elicited by the US. After association with the US, the CS elicits therefore a conditioned response (CR) similar to the UR. A specificity of classical/Pavlovian conditioning is that the outcome follows the CS irrespective of any behavioral responses (Cartoni, Balleine, & Baldassarre, 2016; Dayan & Balleine, 2002; Martin-Soelch, Linthicum, & Ernst, 2007; Schultz, 2006). For instance, a light (i.e. NS) is paired with food (US) delivery, so that the animal or individual learns that the light predicts food delivery. Therefore, classical/Pavlovian conditioning is a learning process centered on the contingency between two stimuli (Martin-Soelch et al., 2007). In this framework, a primary reward acts as an US with an innate positive value and reinforcing effect due to its ability to meet directly biological needs (Lutz & Widmer, 2014). Primary rewards comprise notably food, beverage or sex. The direct positive consequences of primary rewards are therefore crucial for promoting motivated behaviors in animals (Lutz & Widmer, 2014). In humans, behaviors are more complex and often driven by secondary rewards including money or social evaluation. Also referred as conditioned reinforcers, secondary rewards become rewarding by the way of their association with primary rewards (Dayan & Balleine, 2002). Through this classical/Pavlovian conditioning process, a NS gets a positive value by being paired with a reinforcing outcome (Martin-Soelch et al., 2007). Although secondary reward are not directly essential for survival, they are essential for invigorating motivated behaviors in humans (Sescousse, Caldú, Segura, & Dreher, 2013).

The emergence of motivated behaviors is guided by the maximization of positive consequences (i.e. rewards) and/or by the minimization of negative consequences (Lutz & Widmer, 2014; Rolls, 2000). In that respect, behaviors resulting in positive consequences are increased, while behaviors resulting in negative consequences are reduced (Martin-Soelch et al., 2007). Called the instrumental (or operant) conditioning, this learning process received its major impetus from Skinner (1938). Positive reinforcers (e.g. rewards) occurring in close temporal proximity with a response increase the probability and frequency of the rewarded response, whereas negative reinforcers increase the probability and frequency of a response when negative

reinforcers are omitted following the response (Everitt & Robbins, 2005). In sum, reinforcement represents the ability to strengthen the probability of occurrence of a particular behavior (Skinner, 1938). During the instrumental conditioning, an animal or individual learns to associate a consequence (e.g. a reinforcing stimulus such as food) with a contingent response performed previously (e.g. pressing a bar). When the consequence is positive or reinforcing (e.g. food), the probability and frequency of the occurrence of the response is strengthened, whereas a punishing consequence promotes the decrease in the probability and frequency of occurrence of a response (Cartoni et al., 2016; Martin-Soelch, 2009; Schultz, 2006). For instance, a mouse might learn to press a bar to obtain a sweet beverage. In this case, the response (i.e. pressing the bar) is associated with a positive consequence (i.e. a sweet beverage), resulting in the increased probability of occurrence of the learned behavior. Centered on reinforcement and on the contingency between a stimulus and an action (Martin-Soelch et al., 2007), this learning process can lead to two types of instrumental behaviors : (1) habits characterized by the development of a stimulus-response association where the response depends upon the occurrence of the preceding stimulus, or (2) goal-directed behaviors characterized by the development of action-outcome association where the response depends upon the consequence of the previous action (Cartoni et al., 2016).

Taken together, the learning component is a determinant function of reward processing as it enables the emergence of motivated behaviors and the ability to adapt behaviors in changing environmental contingencies to maximize positive consequences (Balleine & Gottfried, 2011). Therefore, motivational and affective components of reward processing are important to establish the value of the consequence following a behavior (Balleine & Gottfried, 2011).

### **2.1.1.2 Motivational component of reward**

In the initial development of psychology, motivation was often seen as a physiological drive to reduce biological needs (Hull, 1943). In this framework, drive described the motivational and energizing state stemming from the physiological needs to reestablish a state of equilibrium (Simpson & Balsam, 2016; Wise, 2004). This internal motivational state was able to invigorate behavioral responses intended to promote survival and to satisfy psychological or physiological needs (Weiner, 1992). However, Hull's theory of drive was not able to explain why the individuals would continue to eat when they feel satiated (Kringelbach, 2007). This led to the idea that individuals were motivated by the expectation of rewards rather than by the drive to satisfy physiological needs *per se*, a concept called incentive motivation (Bolles, 1972). In line with this conceptualization, motivation was more recently defined as “ a process that invigorates motor responding and salience as cues that are attention grabbing or arousing ” (Bissonette & Roesch,

2016, p. 203) or “ the vigor with which a particular action is implemented ” (O’Doherty, 2016, p. 292). In other words, a stimulus is motivational if it is able to promote goal-directed behaviors and actions, as reflected by the effort expended in the instrumental action for getting a reward (Bissonette & Roesch, 2016).

In the framework of the incentive salience hypothesis (K. C. Berridge, 2004; K. C. Berridge & Robinson, 1998; Kringelbach & Berridge, 2017), the motivational component of reward processing is named “ wanting ” and is subdivided into (i) incentive salience and (ii) cognitive desires (K. C. Berridge & Robinson, 2003; K. C. Berridge et al., 2009). The incentive salience is the implicit motivational process which depends upon the motivated behaviors elicited by the reward cue without conscious experience (K. C. Berridge et al., 2009; Tibboel, De Houwer, & Van Bockstaele, 2015). The incentive salience refers to the objective reactions characterized by neural, physiological and behavioral responses (Castro & Berridge, 2014), such as “ the acquisition of a visceral and unconscious desire for a reward ” (M. J. F. Robinson, Fischer, Ahuja, Lesser, & Maniates, 2015, p. 107). The cognitive desires involve the conscious subjective feeling of being motivated to obtain a desired object (K. C. Berridge et al., 2009). At the basis of cognitive desires, expected pleasantness is an additional control system of approach behaviors that constitutes the representation or expectation of how pleasant or unpleasant the receipt of a reward is going to be (K. C. Berridge & Aldridge, 2008). In experimental settings, the motivational component of reward is reflected by the objective and subjective reactivity during or right after the presentation of the reward-associated cue (Pool, Sennwald, Delplanque, Brosch, & Sander, 2016). Based on recent animal data (Hassan & Benarroch, 2015; Schultz, 2016), the motivational component of reward processing was subdivided into motivational salience and motivational valence to characterize the different motivating quality of a stimulus. The motivational salience of a stimulus represents its intensity and is related to the amount of attention that it grabs resulting in higher arousal (Bissonette & Roesch, 2016; Madan, 2013). The valence distinguishes its quality from appetitive to aversive and characterizes its motivational impact (Madan, 2013).

Taken together, the motivational component of reward processing arises from the ability of a reward to give rise to motivation due to its positive value and arousing feature. The present work refers to the concept of motivation as a process characterized by (i) neural and behavioral reactions which result in arousing and energizing effects that invigorates the organism to approach the reinforcer, and in certain cases by (ii) the conscious subjective feeling of being motivated. Here after, we explore the affective component of reward, which is essential for promoting learning and motivation.

### 2.1.1.3 Affective component of reward

In the nineteenth century, Darwin's theory stated that affective reactions had an instrumental function for promoting survival and evolution (Darwin, 1872). In accordance with this view, modern affective neuroscience is still exploring the relationship between affective reactions and survival functions, as well as their neural correlates (LeDoux, 2012). In line with the survival function of reward, "pleasure can be thought of as evolution's boldest trick, serving to motivate an individual to pursue rewards necessary for fitness, yet in modern environments of abundance also inducing maladaptive pursuits such as addictions" (K. C. Berridge & Kringelbach, 2015, p. 2). Pleasure is aroused by the affective component of a reward and results in objective hedonic reactions and subjective hedonic feelings (Schultz, 2006). The English word *hedonic* derives from *hêdoné* in ancient Greek meaning pleasure and stemming from the root *hedus* meaning sweet (K. C. Berridge & Kringelbach, 2015). Although pleasure is often related to the subjective and conscious feeling experienced when consuming or receiving a reward, pleasure is also characterized by objective reactions measured by the neural and behavioral responses elicited (K. C. Berridge & Kringelbach, 2008, 2015).

In the framework of affective neuroscience, pleasure is defined as a "positive hedonic valence, which can occur as either an objective hedonic reaction or a subjective liking reaction to the hedonic impact of a stimulus" (Kringelbach & Berridge, 2017, p. 192). This "liking" reaction characterizes the hedonic effect of reward, resulting in an experience of pleasure (K. C. Berridge, 2004; K. C. Berridge & Kringelbach, 2008; K. C. Berridge & Robinson, 1998; Kringelbach & Berridge, 2017). The affective component of reward processing is subdivided into (i) an objective reaction that might be conscious or unconscious, and (ii) a conscious subjective experience of pleasure (K. C. Berridge & Robinson, 1998; Kringelbach & Berridge, 2017). The affective component of reward might be evaluated by measuring objective neural and behavioral reactions or by individual's rating of affective states elicited during or immediately after the receipt of the reward (K. C. Berridge & Kringelbach, 2008; Pool et al., 2016). This is directly in line with the distinction of emotions as characterized by (i) the emotional state that reflects the physiological changes (i.e. autonomic or endocrine responses) elicited by a positive or a negative event, and (ii) the feelings that represent the subjective emotional experience measured through self-report (Kringelbach, 2005). However, the neural or behavioral hedonic reactions are not always accompanied by a subjective conscious feeling of pleasure (K. C. Berridge & Kringelbach, 2015). In the present work, the concept of pleasure integrates the same distinction with (i) neural and behavioral responsiveness, and in certain cases (ii) a conscious subjective feeling of pleasure characterized by positive emotions such as satisfaction, joy or relief. In the experimental setting,

neural activation during or following immediately the reward delivery are labeled as pleasure or hedonic experience elicited by the reward delivery.

#### 2.1.1.3.1 Hedonic responses, a result of instrumental learning

Positive emotions such as pleasure can be seen as a state produced by instrumental conditioning, in which hedonic reactions including joy or satisfaction should result from the occurrence of positive reinforcers (i.e. palatable food, positive social feedback) or, in turn, from the termination or omission of negative reinforcers (i.e. stressful situations) (Rolls, 2000). According to the instrumental conditioning (see section 2.1.1.1), a positive consequence giving rise to hedonic feelings will increase the probability of occurrence of an action that was contingent upon the positive consequence (Martin-Soelch et al., 2007). In other words, positive emotions should be able to motivate approach behaviors toward beneficial resources, whereas negative emotions play a role in preventing detrimental consequences for the individual by fostering avoidance behaviors (Knutson & Greer, 2008). As discussed in the next section, an important feature of this affective component of reward processing lies in the ability to evaluate the significance of a stimulus in order to learn and to promote adaptive behaviors.

#### 2.1.1.3.2 Reward processing, a special case of emotional processing ?

Reward processing is sometimes considered as a special case of emotional processing, more specifically the processing of positive hedonic stimuli (Kringelbach & Berridge, 2009; J. A. Russell, 2003). In other words, reward processing might constitute an “ affective core ” or a “ valuation system ” in charge of giving the emotional tone to reinforcers through the emotions elicited during their receipt (Schultz, 2002; Zald & Treadway, 2017). Both hedonic feelings and motivation rely on one’s ability to represent the value of environmental stimuli (Cardinal, Parkinson, Hall, & Everitt, 2002). This valuation system includes the subjective value that a person ascribes to a stimulus and the magnitude of arousal elicited by this emotional stimulus (Kable & Glimcher, 2007; Loewenstein, 2000; Zald & Treadway, 2017). In the framework of affective neuroscience, these two dimensions refer to the motivational valence (i.e. subjective value or expected hedonic impact) and to the motivational salience (i.e. arousal) elicited by emotional stimuli (Kringelbach, 2007). Therefore when the consequence is positive, the valuation system results in (i) biological and behavioral responses (e.g. objective hedonic reactions and arousal state) and (ii) in conscious feelings (e.g. subjective hedonic reactions and cognitive desires) (Kringelbach, 2005). What happens, however, when a positive reinforcer such as a reward occurs in an adverse

environment or concurrently with aversive (e.g. stressor) or challenging (e.g. cognitive demands) conditions ? This is a major question explored in the present thesis. In this framework, we were interested in finding out whether adaptive emotion regulation strategies promote the experience of positive emotions such as hedonic feelings during reward delivery, and whether, in contrast, maladaptive emotion regulation strategies are associated with decreased reward responsiveness. The next section explores recent data on the role played by emotion regulation in reward responsiveness.

#### 2.1.1.3.3 How does emotion regulation contribute to reward reactivity ?

Emotion regulation refers to conscious or non-conscious attempts or strategies to influence the trajectory of an emotion by up- or down-regulating the magnitude or the duration of the emotional response (Gross, 2015; Gross, Sheppes, & Urry, 2011). According to Gross's process model of emotion regulation (Gross & Thompson, 2007), emotion regulation strategies are divided into four types, depending on what triggers the process.

The first type of emotion regulation strategy is “ situation selection/modification ”. It refers to acting in a way that will increase the likelihood of experiencing a situation that is expected to elicit pleasant emotions (e.g. distraction such as going to the cinema) or, in contrast, decrease the likelihood of experiencing a situation that is expected to elicit aversive emotions (e.g. avoiding a crowded place) (Gross, 1998). If the situation occurs, one might act in a way that directly influences said situation in order to increase, decrease or modulate its emotional effect (e.g. to switch off the radio when listening to bad news) (Gross, 1998, 2002). The second type of emotion regulation strategy is “ attentional deployment ”. It implicates to focus on a specific object in order to increase, decrease or modulate one's emotional reactivity (e.g. attentional shift by thinking about vacation plan during an annoying meeting) (Gross & Thompson, 2007). The third type of emotion regulation is “ cognitive change ”. It consists in changing one's appraising of a situation in order to increase, decrease or modulate its emotional effect (Gross, 1999; Gross & Thompson, 2007). A famous form of cognitive change is reappraisal which can focus on the meaning of a situation eliciting potentially an emotion (e.g. ‘this discussion with my boss doesn't put me in life-threatening danger, in the worst case I will be fired’) or on the self-relevance of a situation eliciting potentially an emotion (e.g. ‘this situation doesn't involve me or someone I love’) (e.g. Kalisch, 2009). The fourth and last type of emotion regulation strategy is “ response modulation ”. It implicates to act directly on experiential, behavioral or physiological aspects of the emotional reaction after the emotion occurred (e.g. breathing deeply to influence physiological reactivity, eating palatable food to experience positive emotions) (Gross, 2002; Gross & Thompson, 2007).

The use of appropriate strategies to regulate emotional experiences plays a pivotal role in mental and physical well-being (Morawetz, Bode, Baudewig, Jacobs, & Heekeren, 2016). Thus, maladaptive or inefficient emotion regulation might lead to excessive, blunted or improper emotional reactions as evidenced in a variety of emotional disorders such as major depression (for a review see: Aldao, Nolen-Hoeksema, & Schweizer, 2010). Meanwhile, major depression is also characterized by anhedonia or loss of the ability to experience pleasure (Hasler, 2010; Martin-Soelch, 2009; Rizvi, Pizzagalli, Sproule, & Kennedy, 2016). However, very few data exist so far on the relationship linking emotion regulation to reward processing.

Taken together, the ability to consciously and explicitly regulate emotional reactivity might be achieved by (1) the up-regulation of positive and adaptive emotions and (2) the down-regulation of negative or maladaptive emotions (Frank et al., 2014). The prefrontal regions such as the ventrolateral prefrontal cortex (vlPFC) and the dorsolateral prefrontal cortex (dlPFC) have been consistently engaged in emotion regulation, in particular in the execution of emotional up-regulation and down-regulation (Frank et al., 2014; Kohn et al., 2014; Wager, Davidson, Hughes, Lindquist, & Ochsner, 2008). Successful emotion regulation might be achieved by promoting the up-regulation of positive adaptive emotions over negative emotions or by down-regulating negative emotions (Frank et al., 2014; Morawetz et al., 2016; Ochsner et al., 2004). In other words, successful emotion regulation might contribute to enhance reward responsiveness, as suggested by the recruitment of the ventral striatum during the up-regulation of positive emotions (Kim & Hamann, 2007; Morawetz, Bode, Baudewig, & Heekeren, 2017), a core region embedded in the reward system as discussed later in the section 2.1.3.

Below, Figure 2.1 illustrates the relationships linking the learning, motivational, and affective components along with their functions in reward processing.

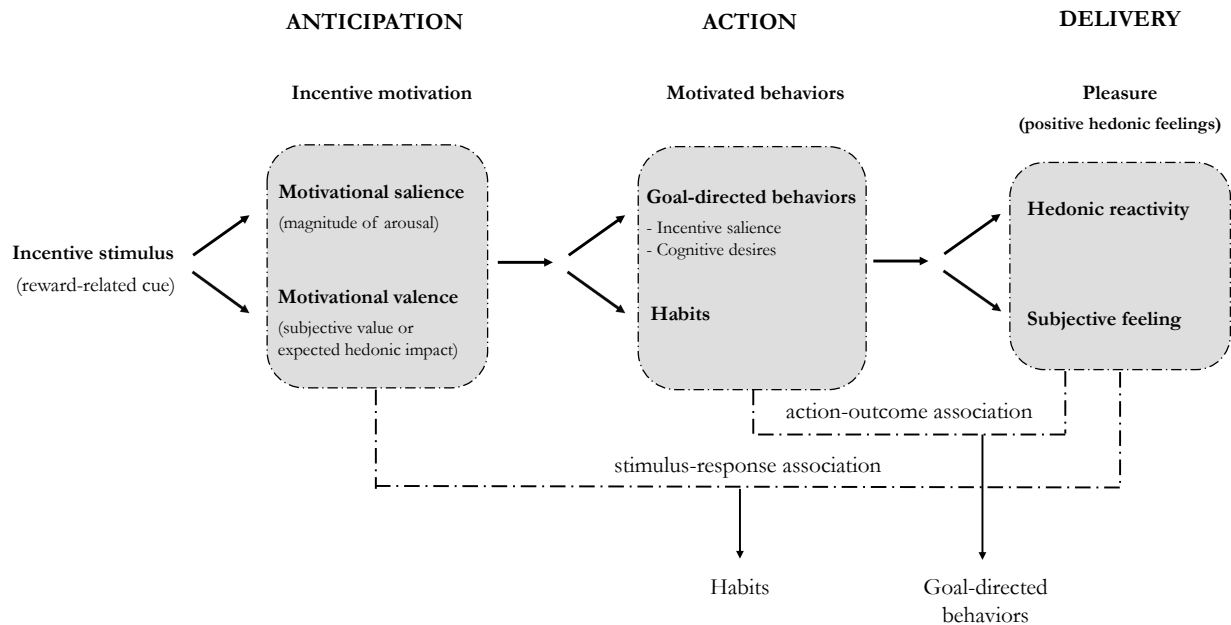

*Figure 2.1.* Relationships linking the learning, motivational, and affective components, and their functions in reward processing. After the occurrence of a cue predicting a reward, a valuation process is engaged during the anticipation phase. The predicted reward is evaluated in terms of motivational salience (i.e. magnitude of arousal elicited by the predicted reward) and the motivational valence (i.e. subjective value or expected hedonic impact of the predicted reward), giving rise to a certain magnitude of incentive motivation further translated into motivated behaviors. Two types of motivated behaviors are commonly described, goal-directed behaviors as result of instrumental learning (i.e. learning of action-outcome associations) and habits or more automatized behaviors as result of Pavlovian learning (i.e. learning of stimulus-response associations). The reward delivery comprises the objective hedonic reactivity and the subjective feeling experienced during the reward delivery, both giving rise to the experience of pleasure.

Before turning our attention to the neurobiological substrates of the reward processing, the next section focuses on the different types of experimental tasks developed over the past decades for studying the different mechanisms implicated during the reward processing.



## 2.1.2 Experimental tasks to study reward processing

Over the past decades, affective neuroscience has emerged as an exciting discipline to better understand the brain processes involved in the processing of reward, and how reward processing is related to motivation and pleasure. However, the study of the reward processing is challenging, because it involves several complex affective, cognitive, and behavioral mechanisms. For studying more precisely the neural correlates involved in the reward-related processes in humans, one strategy consisted in developing experimental tasks which assessed specific reward-related behaviors in order to decompose complex processes into smaller parts (Richards et al., 2013). To explore reward-related processes, three main categories of experimental tasks were commonly used: passive reward tasks, instrumental-reward tasks, and reward decision-making tasks. In these tasks, the anticipation phase and the delivery phase are the two main stages which are usually differentiated to reflect the distinct psychological and neural processes at stake, namely the motivational processes and hedonic experiences (i.e. positive affective state elicited during delivery).

### 2.1.2.1 Passive reward tasks

These tasks implicate the simple presentation of rewards without requiring the individual to perform any action for obtaining the reward (Richards et al., 2013). They comprise, among others, the different types of slot-machine tasks (e.g. Donkers, Nieuwenhuis, & van Boxtel, 2005; Van Leijenhorst et al., 2010) or roulette wheel games (Hakymez, Dagher, Smith, & Zald, 2008). In one type of slot machine task presented in Figure 2.2, three slot machines are successively displayed during the anticipation phase. Each slot machine displays pictures of fruit one by one. Participants are rewarded if, during the delivery phase, the slot machine displays three pictures of the same fruit (Van Leijenhorst et al., 2010).

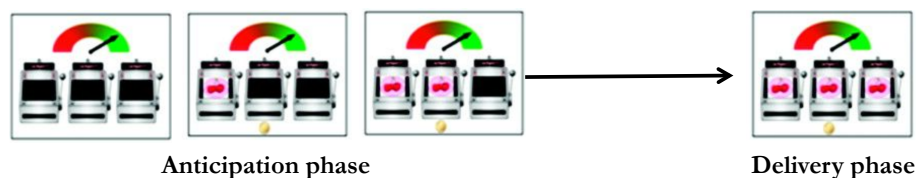

*Figure 2.2.* Illustration of a version of the slot-machine task, a passive reward task. Modified from Van Leijenhorst et al. (2010, p. 63).

Passive viewing tasks use another type of paradigms to assess the processing of positive compared to neutral or negative emotions without any performance required from the participant.

In such tasks, participants are asked to passively look at stimuli with positive, neutral, or negative valence. Additionally, the level of arousal (low- vs high-arousing) can be modulated independently of the valence (Cuthbert, Schupp, Bradley, Birbaumer, & Lang, 2000; Feng et al., 2014). The stimuli might be for instance an emotionally arousing picture selected from the International Affective Picture System (IAPS; Lang, Bradley, & Cuthbert, 2008; Lang, Davis, & Öhman, 2000) or the picture of a palatable low- or high-caloric food (Blechert, Klackl, Miedl, & Wilhelm, 2016; Murdaugh, Cox, Cook, & Weller, 2012) selected from standardized food images (Charbonnier, van Meer, van der Laan, Viergever, & Smeets, 2016).

### **2.1.2.2 Instrumental-reward tasks**

This type of task requires participants to perform an action or to give a cognitive response (instrumental component) to obtain a reward during the delivery phase (Richards et al., 2013). The performance required during the cognitive/motor phase might consist of a working memory (WM) test or a timed button press response for example. In this type of task, the positive (i.e. gain) or negative (i.e. loss) value of incentives depends directly on the performance of the participant. For instance, the Monetary Incentive Delay (MID) task (Knutson, Westdorp, Kaiser, & Hommer, 2000) is a widely used instrumental-reward task in neuroimaging studies. It was developed to assess the neural correlates of the reactivity to reward and loss in humans. Specifically, this task distinguishes five phases: (i) the cue presentation indicating the potential gain or loss on the trial, (ii) an anticipation phase consisting in a delay period during which the participant is preparing for performing the upcoming test, (iii) a cognitive or motor phase when the participant must perform the test, (iv) an expectation phase consisting in another delay period during which the participant is expecting a given gain or loss based on his performance, and (v) the delivery phase during which the positive (+\$1 or +\$5), negative (-\$5 or -\$1) or neutral (\$0) outcome is presented (see Figure 2.3). On potential win trials, a successful performance (correct answer corresponding to a button press response performed when the target is still displayed on the screen) results in the delivery of a reward corresponding to the magnitude related to the cue presented at the beginning of the trial. Similarly, an unsuccessful performance (button press response preceding or occurring after target offset) results in no reward delivery (\$0). On loss trials, a successful performance results in no loss delivery (\$0) and an unsuccessful performance in loss, corresponding to the predicted cue-related loss.

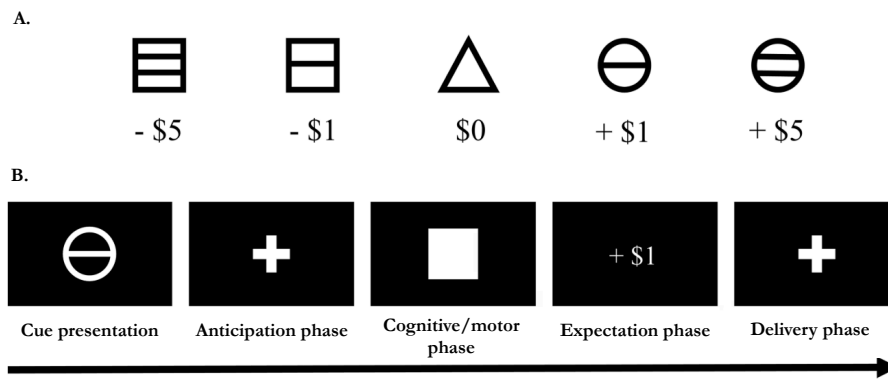

*Figure 2.3.* Illustration of a version of the Monetary Incentive Delay (MID) task. (A) Incentive-related cues presented during the task and indicating the type of trial. (B) Illustration of a win trial with a potential win of +\$1 following a successful performance. Modified from Oldham et al. (2018, p. 3400).

Of particular importance for the empirical works presented in this thesis, our experimental task is part of the instrumental-reward tasks, in which reward delivery is dependent upon successful performance on the cognitive task. Similarly to the MID task, our experimental task comprises an anticipation phase (i.e. cue predicting a reward or no reward), a cognitive phase (i.e. working memory performance), an expectation phase, and a delivery phase (i.e. notification of the monetary reward). In contrast to some versions of the MID task, our reward task didn't include any loss condition.

### 2.1.2.3 Decision-making tasks

The structure and phases of this type of tasks are usually very similar to those of instrumental-reward tasks. However, decision-making tasks require participants to select one among several options, each option (decision-making component) being associated with a reward of different magnitude, and a different probability of obtaining it (Richards et al., 2013). The decision-making component consists of evaluating and comparing each option based on the magnitude of the reward, the likelihood of receiving it, and the risk it entails. In particular, this task involves a valuation process including attribution of value, integration and eventually re-appraisal based upon previous outcomes. Among others decision-making tasks, the Wheel Of Fortune task (WOF) task (e.g. Dichter et al., 2009; Ernst et al., 2004; Pedroni, Koeneke, Velickaite, & Jäncke, 2011; Smith, Tindell, Aldridge, & Berridge, 2009) involves probabilistic monetary win or loss. In each trial, two competing options are presented to the participants. Each option is associated with different magnitudes and likelihood of winning this amount of money. When the computer chooses the same choice as the one the participant made during the cognitive/motor phase, the participant wins the amount indicated in the cue presentation phase (see Figure 2.4).

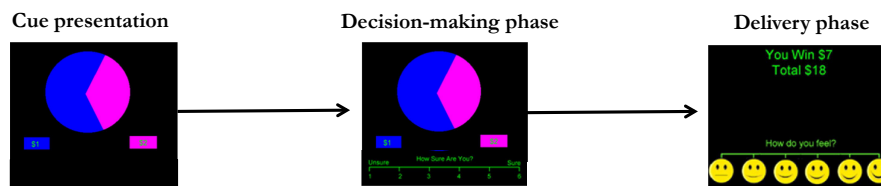

Figure 2.4. Illustration of a version of the Wheel of Fortune (WOF) task. A trial of the WOF task with moderate likelihood of winning \$1 (70% of risk) and moderate likelihood of winning \$2 (30% of chance). Modified from Ernst et al. (2004, p. 1587).

Taken together, various experimental tasks can be used to assess the behavioral and neural responses during the different stages of the reward processing. In the present work, we are more specifically interested in the neural, affective and behavioral processes involved during the reward processing in relationship with performance. Consequently, the literature presented and discussed in the next sections focuses on neuroimaging and behavioral studies using instrumental reward tasks.

### 2.1.3 Reward processing in the brain

Understanding how motivation and positive emotions such as pleasure are generated in the brain is crucial, as they are essential for promoting adaptive behaviors and well-being (Kringelbach & Berridge, 2010). Experimental works in animals have provided a fundamental basis for our understanding of the neural structures that might be involved in the reward function (McClure, 2004). An important challenge is being able to translate the key findings from animal studies to the human brain mechanisms (Haber & Knutson, 2010). In this framework, functional magnetic resonance imaging (fMRI) emerged as a reliable and consistent method for exploring the human brain, and how specific brain regions are implicated in motivational and hedonic processes (McClure, 2004). In this section, the reward circuitry of the human brain is first briefly described. Then, we review some contributions brought by pharmacological and intracranial self-stimulation studies, which are important for our understanding of the neurochemical reward systems. Therefore, we shortly cover key animal findings which widely contributed to map the specific anatomical sites and to evidence the determinant neurotransmitters implicated in the learning, motivational, and affective (i.e. hedonic) components of reward processing. Finally, these findings are put into perspective in the light of human neuroimaging studies that explored the neurobiological correlates engaged during the reward anticipation and reward delivery.

### 2.1.3.1 Neuroanatomy of the reward circuitry

The convergence between primate anatomy studies and human fMRI studies helped to build our current knowledge about the anatomy of the structures and pathways of the reward circuitry (Haber & Knutson, 2010). In humans, the reward circuitry has been described as part of the cortico-basal ganglia network with core regions including the ventral striatum and the midbrain areas, more specifically the ventral tegmental area (VTA) and the substantia nigra pars compacta (SNc) (Haber & Knutson, 2010).

The basal ganglia have been traditionally involved in affective (limbic), cognitive (associative), and motor processing in parallel (Alexander & Crutcher, 1990). The basal ganglia consists of the nucleus accumbens, the caudate nucleus, the putamen, and the globus pallidus, tightly related to the midbrain areas including the VTA and the SNc (Haber, 2003). The concept of ventral striatum refers to the ventral extension of the striatum consisting of the nucleus accumbens (NAcc), the ventral caudate nucleus and the ventral putamen (dorsal and lateral parts of the ventral striatum) (Haber, 2003). The ventral striatum represents the major inputs and outputs structure of the basal ganglia, receiving primary projections from cortical regions including the orbitofrontal cortex (OFC), ventromedial prefrontal cortex (vmPFC), insula, dorsal prefrontal cortex (PFC), and cingulate cortex such as the dorsal anterior cingulate cortex (dACC) (Haber, 2011). The dorsolateral striatum receives cortical inputs from sensory-motor areas, while the central striatum receives cortical inputs from associative areas (Haber, 2011). The OFC and insula, in particular, receive direct sensory inputs from all modalities, and project mainly to the ventral striatum and central striatum (Haber, 2003; Haber & Knutson, 2010). Also associated to sensory processing, the amygdala projects substantially to the ventral striatum and central striatum (Haber, 2011). The vmPFC sends inputs essentially to the shell of the NAcc as well as to the medial part of the caudate nucleus, while the dACC projects most laterally and the dorsal PFC sends projections essentially to the caudate nucleus (Haber, Kim, Maily, & Calzavara, 2006).

In turn, the ventral striatum sends innervation to the ventral pallidum, SNc and VTA (Haber, 2011). These regions project back to the medial dorsal nucleus of the thalamus, which transmits this information to the OFC and anterior cingulate cortex (ACC) that translates it into action (Haber, 2003; Richards et al., 2013). Figure 2.5 illustrates the reward circuitry with the main afferent and efferent projections of the striatum.

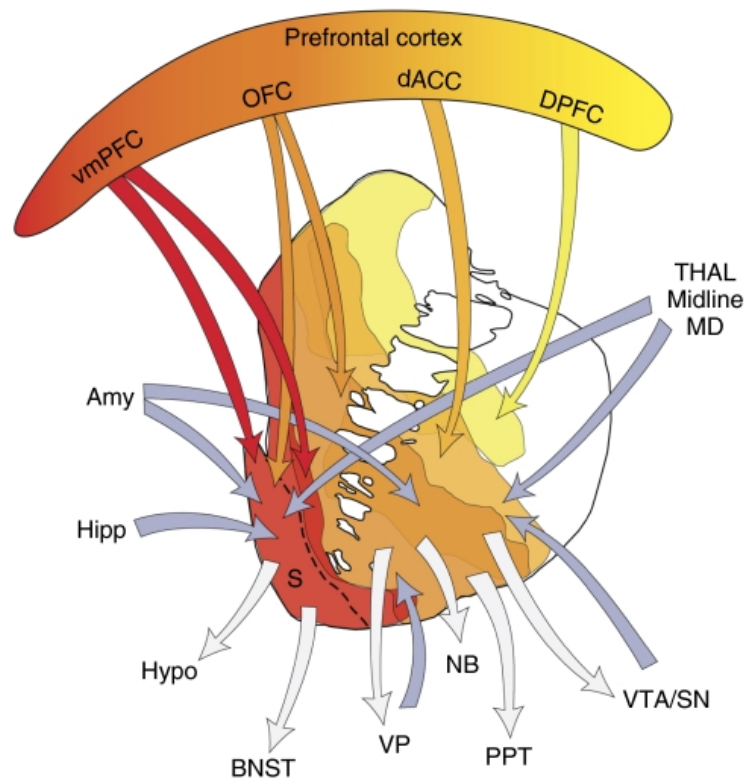

*Figure 2.5.* Illustration of the main afferent (input) and efferent (output) connections of the striatum. Arrows with distinct colors characterize the different types of connections, with blue arrows for inputs to the striatum, gray arrows for outputs from the striatum, red arrows for the inputs from the ventromedial prefrontal cortex (vmPFC) to the ventral striatum (VS) shell and to the medial part of the caudate nucleus, dark orange arrows for the inputs from the orbitofrontal cortex (OFC) to the VS shell and to the central striatum, light orange arrows for inputs from the dorsal prefrontal cortex (DPFC) to the caudate nucleus. Amy, amygdala; BNST, bed nucleus stria terminalis; dACC, dorsal anterior cingulate cortex; Hipp, hippocampus; hypo, hypothalamus; MD, medial dorsal nucleus of the thalamus; PPT, pedunculopontine nucleus; S, shell; SNc, substantia nigra, pars compacta; STN, subthalamic nucleus; THAL, thalamus; VP, ventral pallidum; VTA, ventral tegmental area. Retrieved from Haber & Knutson (2010, p. 9).

Although the mechanisms promoting motivated behaviors and positive emotions such as hedonic feelings involve an extended set of brain regions as described above, the empirical works presented in this thesis will focus on the striatum, a core region implicated in the reward processing. The next section covers the literature that aimed at localizing the brain regions involved in the reinforcement and in the invigoration of motivated behaviors, as well as the brain centers responsible for the generation of pleasure and of hedonic feelings.

### 2.1.3.2 Neurochemical reward systems

The influential discovery of Olds and Milner (1954) initiated a great interest among researchers for localizing specific brain hotspots and neurotransmitters dedicated to the generation of pleasure. In their seminal study using intracranial self-stimulation, Olds and Milner (1954) reported that rats with electrodes implanted in specific subcortical regions would work for electrical stimulations by pressing a lever to discharge electrical stimulations through the electrodes in these specific brain regions located in the midbrain dopaminergic (DAergic) system including the lateral hypothalamus, the septum area, and the NAcc. This led to the idea of pleasure centers formed by the lateral hypothalamus and related regions (Olds, 1956). In line with the idea of pleasure centers, further studies evidenced the relationship between the electrical stimulation of the lateral hypothalamus and increased eating behaviors in satiated animals, interpreting these approach behaviors as the result of the hedonic feelings elicited by the stimulation of specific limbic regions (for a review see: Valenstein, Cox, & Kakolewski, 1970). Converging with animal studies, the reinforcing effects produced by the self-stimulation of DAergic neurons located in subcortical brain areas were also evidenced later in humans (Bishop, Elder, & Heath, 1963).

These findings gave rise to the (an)hedonia hypothesis formulated by Wise et al. (1982), one of the most influential hypothesis linking dopamine (DA) to pleasure in the brain. According to the (an)hedonia hypothesis, the stimulation of midbrain DAergic neurons triggers drive states associated to the hedonic feelings experienced during the stimulation, supporting the idea that midbrain DAergic neurons act as brain mediators between the hedonic experience elicited by primary and secondary rewards delivered after an appropriate action and the consecutive reinforcement of this action resulting in the increase of approach behaviors (Wise, 2004).

In the early nineties, the role of the midbrain DA neurons in pleasure was nevertheless called into question. Notably, DA depletion in the striatum of rats didn't affect their ability to experience pleasure in response to the consumption of a sweet solution (i.e. sucrose) as reflected by their orofacial "liking" reactions (K. C. Berridge & Robinson, 1998). In line with animal findings, a human study investigated the effect of decreased DA synthesis, induced pharmacologically by acute phenylalanine/tyrosine depletion, on hedonic responses to the consumption of a stimulant drug (i.e. *d*-amphetamine) (Leyton, Young, & Benkelfat, 2007). DA depletion didn't reduce the hedonic effects of the stimulant drug, however DA depletion resulted in decreased reward-related performances (Leyton et al., 2007). While DA has long been considered as the brain's pleasure neurotransmitter, the next two sections explore the major scientific contributions to our understanding of its role in the learning and motivational components of

reward processing. Then, the third section covers the recent progress in our knowledge about the brain regions and neurochemical receptors engaged in the generation and experience of pleasure.

#### 2.1.3.2.1 Role of midbrain dopamine neurons in the learning component of reward

Despite its early label as the brain's pleasure neurotransmitter (Wise, 1982), DA is no longer seen as the mediator of pleasure (Olney, Warlow, Naffziger, & Berridge, 2018). Over the past decades, an influential theory linked the midbrain DA neurons activation of primates to reward prediction (O'Doherty, Cockburn, & Pauli, 2017; Schultz, 1997; Schultz, Apicella, & Ljungberg, 1993; Schultz, Stauffer, & Lak, 2017). In a series of pioneering works in monkeys, Schultz and colleagues evidenced that the midbrain DA neurons located in the VTA responded to the receipt of palatable stimuli, but also to cues that predicted the delivery of food (Romo & Schultz, 1990). Primary palatable rewards and information about appetitive events elicited phasic DA responses (i.e. high-frequency burst firing) in the VTA, while aversive stimuli led essentially to the inhibition of the same DA neurons (i.e. short silencing of electrical activity) (Schultz, 1997). DA neurons didn't respond, however, to fully predicted reward. This discovery led to the formulation of the concept of reward prediction error (PE) which describes the phasic activation of the midbrain DA neurons as " a short-latency, phasic reward signal indicating the difference between actual and predicted rewards " (Schultz, 2002, p. 241). In other words, the phasic DA signalling is linked to the degree to which the reward delivered is expected or not, with enhanced firing when the reward delivery is unexpected (Schultz, 2002, 2013). Specifically, a positive reward PE is characterized by an unexpected reward or a reward better than expected, resulting in positive reinforcement which promotes approach behaviors and potentially positive emotions (Schultz, 2017). In turn, a negative PE is marked by the absence of reward or by an aversive event, giving rise to avoidance behaviors and possibly to negative emotions (Bromberg-Martin, Matsumoto, & Hikosaka, 2010; O'Doherty et al., 2017; Schultz, 2007a; Ungless, Argilli, & Bonci, 2010). Although the occurrence of aversive events is essentially related to a decrease in the phasic activation of DA neurons, a small proportion of midbrain DA neurons shows also phasic activation in response to the occurrence of aversive events (Schultz, 2002). This important discovery in primates opened new avenues to our understanding of the mechanisms linking DA to the learning of instrumental actions and to motivated behaviors (O'Doherty et al., 2017; Schultz, 1997; Schultz et al., 1993, 2017). Converging with findings in animal, phasic DA firing in the dorsal striatum in response to unexpected rewards (i.e. reward PE signals) were associated with increased behavioral performance in humans, demonstrating the role played by DAergic activity in the dorsal striatum for learning to perform actions associated with rewards (Schonberg, Daw, Joel, & O'Doherty, 2007).



Taken together, research over the past 30 years reported that DA neurons fire to indicate an unexpected reward or a reward better than expected, resulting in the reinforcement of approach behaviors and potentially in the experience of positive emotions (Bromberg-Martin et al., 2010; O'Doherty et al., 2017; Schonberg et al., 2007; Schultz, 2007b, 2017; Ungless et al., 2010). In contrast, the decrease in phasic firing of DA neurons results mainly from the absence of reward or from the occurrence of an aversive event such as a stressor for instance (Bromberg-Martin et al., 2010; Schultz, 1997, 2017).

In the following section, we first review in a non-exhaustive way findings in animals and humans that contributed to deepen our understanding of the implication of the midbrain DA neurons in goal-directed behaviors. This propensity to engage in motivated behaviors involves the ability to integrate the motivational salience of incentives and their value. Therefore, the following section covers, as a second step, the recent findings in non-human primates on the differential implication of the midbrain DA neurons in the encoding of the motivational salience and motivational valence of incentives, as well as the brain regions involved in these processes.

#### 2.1.3.2.2 Role of midbrain dopamine neurons in the motivational component of reward

The ability of DA to influence motivation was first evidenced by a lesion study performed in rats and showing the dramatic effects produced by the lesion of the nigrostriatal DA pathway on the initiation of reward-seeking behaviors, with a significant decrease in motivated behaviors toward palatable rewards (Ungerstedt, 1971). In line with animal data, human studies demonstrated the association between increased DA concentrations in the mesolimbic pathway and the amount of effort expended to obtain a reward (for a review see: Pool et al., 2016). For instance, the willingness to mobilize greater effort for larger rewards was linked to increased level of striatal DA concentrations in humans (Treadway, Buckholtz, et al., 2012). To investigate the role of midbrain DA activity in motivated behaviors to obtain tobacco, a pharmacological study manipulated midbrain DA activity by inducing an acute phenylalanine/tyrosine depletion to decrease DA synthesis (Venugopalan et al., 2011). This study evidenced that diminished midbrain DA concentrations resulted in a reduction of reward-seeking behaviors such as the effort mobilized to obtain cigarettes in abstinent smokers. Converging with the idea that DA plays a role in promoting motivated behaviors and in learning goal-directed (i.e. instrumental) actions rather than in the experience of pleasure, the effort mobilized for obtaining a reward was not related to the hedonic feelings experienced during the reward delivery (for a review see: Pool et al., 2016).

Over the past decades, the motivational quality of incentives was distinguished into a salience component and a valence component, so that approach behaviors are driven by both the

arousing effect and the positive value of rewards (for a review see: Bromberg-Martin et al., 2010). Accordingly, recent works have suggested the existence of differential DAergic mechanisms involved in the encoding of the motivational salience and motivational valence (Hassan & Benarroch, 2015; Schultz, 2016). Two sequential DA signalings take place during the processing of unexpected rewards, with an initial fast phasic activation of midbrain DA neurons followed by a second slower DA signalling (Schultz, 2016). The initial brief response of DA neurons is unselective and reacts to the physical salience of the stimulus, with the aim of detecting rapidly a wide range of environmental stimuli of sufficient intensity. The second DA response (i.e. activation or depression) is thought to reflect the positive value of the stimulus, and to code the positive or negative PE (Schultz, 2016; Schultz et al., 2017). As illustrated in Figure 2.6, the midbrain DA neurons encoding motivational salience are located in the dorsolateral SNc and project essentially to the dorsolateral striatum including the caudate nucleus and the putamen. In turn, the midbrain DA neurons encoding motivational valence are located in the lateral VTA and project mainly to the ventral striatum including the core and shell of the NAcc (Hassan & Benarroch, 2015).

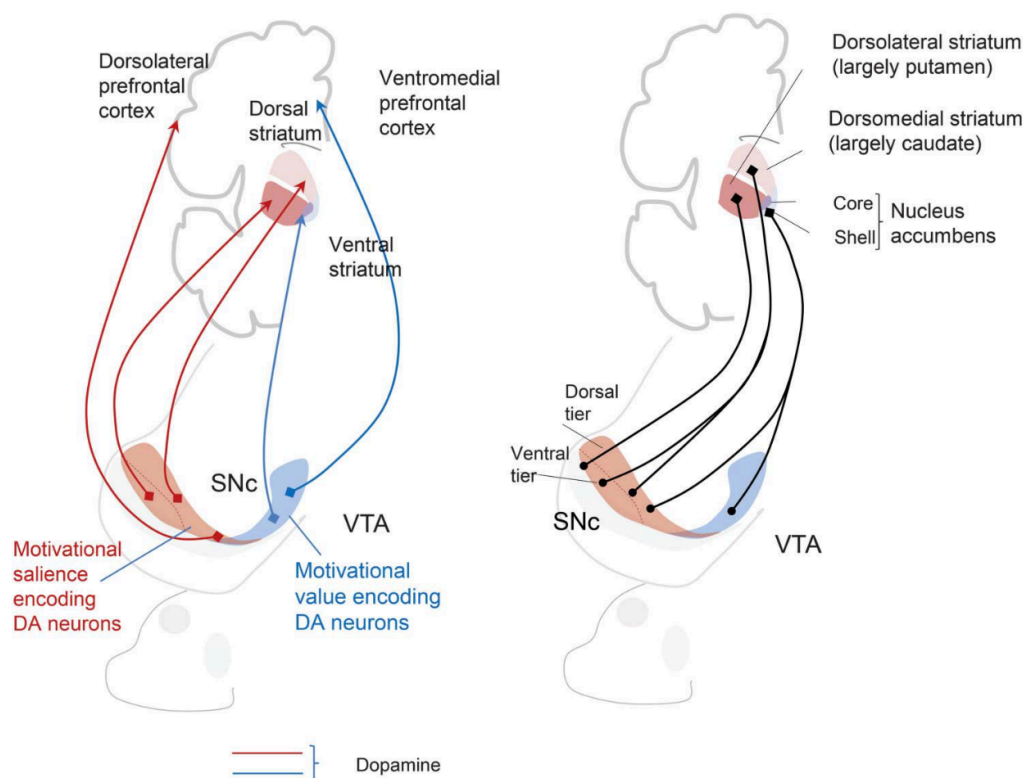

*Figure 2.6.* Illustration of the main projections of the midbrain dopamine (DA) neurons located in the substantia nigra pars compacta (SNc) and in the ventral tegmental area (VTA). The midbrain DA neurons coding the motivational valence are mainly located in the VTA and project essentially to the dorsolateral striatum including the caudate nucleus and the putamen. The midbrain DA neurons coding the motivational salience are mainly located in the SNc and project essentially to the ventral striatum, in particular the core and the shell of the nucleus accumbens. Retrieved from Hassan and Benarroch (2015, p. 1797).

Taken together, these findings contributed importantly to our understanding of the brain regions involved in the motivational component of reward processing, and how their engagement promotes goal-directed behaviors. Notably, studies in primates brought important contributions for understanding the reward processing by evidencing that specific midbrain DA neurons are engaged in the encoding of the motivational salience, while other midbrain DA neurons are dedicated to the encoding of motivational valence (for reviews see: Hassan & Benarroch, 2015; Schultz, 2016). Midbrain DA neurons encoding motivational salience and motivational valence are anatomically segregated within specific target regions that are the regions of interest in human fMRI studies. Specifically, the initial short-latency DA signalling reflects the phasic activation of midbrain DA neurons elicited by the motivational salience of the stimulus, in terms of arousal produced by positive stimuli and by aversive stimuli. These DA neurons involved in the encoding of the motivational salience are mainly localized in the SNc that, in turn, projects to the dorsolateral and dorsomedial striatum, including respectively the putamen and the caudate nucleus. The second and slower DA signalling characterizes the phasic DA release elicited by the encoding of the subjective value of rewards, in particular unexpected rewards. The midbrain DA neurons involved in the motivational value are located in the VTA which mainly projects to the ventral striatum and to the vmPFC. Specifically, these regions targeted by DA projections have elicited a major interest in the fMRI studies exploring the neural correlates underlying the reward processing in humans.

In the following section, we take a look at the recent progress in our knowledge about the brain regions and neurochemical receptors involved in the encoding of the affective component of reward and thought to be at the basis of the pleasure generation.

#### 2.1.3.2.3 Role of endocannabinoid and opioid receptors in the affective component of reward

The critical question whether specific brain centers and neurotransmitters are dedicated to the experience of pleasure remained unanswered since the role played by DA as the mediator of pleasure was called into question (Olney et al., 2018). While affective expressions characterizing the hedonic experience of pleasure were found in humans and many animal species such as monkeys (Steiner, Glaser, Hawilo, & Berridge, 2001) and rodents (Grill & Norgren, 1978), research in affective neuroscience started to explore the neural generators of pleasure in animals with the aim of bridging animal and human findings. In this framework, the experience of pleasure or the hedonic reactions have been measured by recording the affective orofacial expressions elicited by the hedonic impact produced by the consumption of a sweet stimulus (Kringelbach & Berridge, 2010). This procedure conducted in rodents demonstrated the existence of specific hedonic centers located in the subcortical (i.e. NAcc and ventral pallidum) and the cortical (i.e. insula, medial and

lateral OFC) regions, as well as in brainstem regions (i.e. parabrachial nucleus in the pons) (for a review see: K. C. Berridge & Kringelbach, 2015).

These centers measure about one cubic millimeter in the rodent brain, and are called **hedonic hotspots**. They are able to enhance the hedonic reactions in response to pleasant events when opioid or endocannabinoid receptors within the hedonic hotspots are stimulated (Kringelbach & Berridge, 2010). For instance, the activation of opioid receptors through the microinjections of drug in hedonic hotspots in the NAcc shell (Castro & Berridge, 2014; Mahler, Smith, & Berridge, 2007; Pecina & Berridge, 2005) and in the ventral pallidum (Smith & Berridge, 2005; Tindell, 2004; Tindell, Smith, Pecina, Berridge, & Aldridge, 2006) resulted in a strong amplification of the orofacial hedonic reactions produced by a sweet taste. Similarly, the stimulation of endocannabinoid receptors through the microinjections of anandamide into the NAcc shell of rats increased the hedonic impact of a sweet taste (Mahler et al., 2007). In contrast, other centers called **hedonic coldspots** are capable of diminishing or suppressing (i) the hedonic reactions to pleasant stimuli (Kringelbach & Berridge, 2010), and (ii) the negative affective reactions in response to unpleasant stimuli (Pecina & Berridge, 2005). For instance, the microinjection of an opioid agonist in ventral pallidum coldspots suppressed eating behaviors in rats (Smith & Berridge, 2005), while hedonic reactions to sweet rewards were supported by the inhibition of NAcc neurons localized in coldspots (Roitman, Wheeler, Tiesinga, Roitman, & Carelli, 2010).

Taken together, animal studies suggest the existence of small anatomical sites responsible for the generation of pleasure or for the amplification of the hedonic impact elicited by pleasant events, provided that opioid and endocannabinoid neurochemical receptors are simultaneously stimulated. These hedonic hotspots have been located in specific sites of the NAcc, pallidum, insula, OFC, pons and brainstem. Specifically, these rodents studies contributed to enhance our understanding of how hedonic responses might be generated in the human brain, opening new avenues for studying the neural substrates underlying the experience of pleasure in humans. Since fMRI human studies usually measure pleasure as the neural responsiveness induced by the receipt of positive consequences, these findings suggest that hedonic feelings in the human brain might be generated essentially by the activation of opioids and endocannabinoids receptors located in very specific and limited hotspots across the brain. The next section covers the literature on the neural correlates involved during the reward anticipation and during the reward delivery in humans, and the potential functions thereof.

### **2.1.3.3 Neural correlates of reward processing in humans**

Although the neural substrates at the basis of the reward processing elicited considerable interest in cognitive neuroscience, neuroimaging studies failed to draw a consistent picture of the brain regions recruited during the distinct phases of reward processing including reward anticipation and delivery (Diekhof, Kaps, Falkai, & Gruber, 2012). Some findings suggested for instance that the ventral striatum was preferentially engaged during reward anticipation compared to reward delivery (for a review see: Knutson & Greer, 2008), whereas recent research evidenced the strong implication of the ventral striatum during reward delivery (for a meta-analytic review see: Xun Liu, Hairston, Schrier, & Fan, 2011).

Even though it is often difficult to disentangle the motivational from the affective (i.e. hedonic) components of the reward processing in humans (Pool et al., 2016), this section has two objectives. Its first aim is to present the neural correlates of reward processing involved during the reward anticipation by trying to single out the differential implication of brain regions in the encoding of the motivational salience, of the motivational valence, and of the magnitude of positive incentives. Its second aim is to cover the literature in humans that documents the neural correlates of the reward processing during the reward delivery, the component of reward processing that is thought to reflect the positive emotions and the hedonic experience elicited by the reward. To fulfil these two objectives, we reviewed the existing meta-analytic studies that reported the consistent neural correlates of reward anticipation and reward delivery across studies conducted in healthy humans. Here after, Table 2.1 summarizes the main findings reported by these meta-analyses as well as the experimental tasks, the types of incentives, and the reward processing phases investigated by the studies included in these meta-analyses. We discuss these results and their implications for the reward anticipation in the section 2.1.3.3.1 and for the reward delivery in the section 2.1.3.3.2.

Table 2.1

*Meta-analytic reports of the neural correlates implicated in the reward processing during the anticipation and the delivery of rewards in healthy humans*

Authors	Number of fMRI studies	Tasks	Reward valence		Neural correlates during anticipation		Neural correlates during delivery
			Positive incentives	Neutral or negative incentives	Motivational salience	Reward valence	
Bartra et al. (2013)	206	Considerable heterogeneity in the experimental tasks included without details about the specific tasks.	e.g. monetary win, administration of a sweet taste, positive pictures, positive social feedback	e.g. monetary loss, administration of a bitter taste, aversive pictures, negative social feedback	aINS Striatum	ACC aINS Brainstem PCC Pre-SMA Striatum vmPFC	/
Diekhof et al. (2012)	24	Reward passive task (e.g. delivery of sweet taste or food-related odor), Instrumental-reward tasks (e.g. MID task), Decision making reward tasks (e.g. gambling task with rewards and penalties).	Monetary win, sweet taste or odor, viewing of happy faces.	Monetary loss, aversive taste or odor.	/	ACC aINS SMA Thalamus Ventral striatum VTA	/
Diekhof et al. (2012)	47	Reward passive task (e.g. delivery of sweet taste or food-related odor), Performance-dependent tasks (e.g. MID task), Decision making reward tasks (e.g. gambling task with rewards and penalties).	Monetary win, sweet food-related odor, high- or low-fat drink, tasty drink viewing of attractive faces.	Monetary loss, aversive food-related odor, tasty drink viewing of neutral faces.	/	/	Amygdala Angular gyrus Fusiform gyrus Hippocampus Lingual gyrus mOFC mSFG NAcc PCC vmPFC

Authors	Number of fMRI studies	Tasks	Reward valence		Neural correlates during anticipation		Neural correlates during delivery
			Positive incentives	Neutral or negative incentives	Motivational salience	Reward valence	
Liu et al. (2011)	142	Reward passive tasks (e.g. consumption of sweet taste), Instrumental-reward tasks (e.g. MID task, signal-detection task, temporal discounting reward tasks), Decision making reward tasks (e.g. WOF task, sequential investment task, gambling task with rewards and penalties), Reward learning tasks (e.g. probabilistic reversal learning task).	monetary win, avoidance of monetary loss, win of the larger reward among several options, loss of the smaller sum among several options, administration of a sweet taste, encouraging words or images	monetary loss, absence of reward, loss of the smaller sum among several options, loss of the smaller sum among several options, administration of a bitter taste, discouraging words or images	aINS dlPFC NAcc	aINS dlPFC NAcc mOFC IPL	aINS dlPFC mOFC NAcc
Oldham et al. (2018)	50	MID task (Instrumental-reward tasks)	monetary win	monetary loss	aINS Amygdala Caudate Cerebellum Midbrain NAcc SMA Thalamus	aINS Amygdala Cuneus Midbrain NAcc Occ cortex Premotor cortex SMA Thalamus	Amygdala NAcc OFC/vmOFC PCC
Wilson et al. (2018)	15	MID task (instrumental-reward task)	monetary win	monetary loss	Caudate Hippocampus MFG Putamen SFG	Caudate ITG MFG NAcc Occ gyrus Paracentral lobule Parahippocampal gyrus Putamen SFG	/

*Note.* The anticipation phase was defined as the time period where the prospect of a reward or a loss is presented to the participant. The delivery phase was defined as the time period where the participant receives the feedback about reward or loss. ACC, anterior cingulate cortex ; aINS, anterior insula ; dlPFC, dorsolateral prefrontal cortex ; dmPFC, dorsomedial prefrontal cortex ; IPL, inferior parietal lobule ; ITG, inferior temporal gyrus ; OFC, orbitofrontal cortex ; MID task, monetary incentive delay task ; MFG, middle frontal gyrus ; mOFC, medial orbitofrontal cortex ; NAcc, nucleus accumbens ; Occ, occipital ; PCC, posterior cingulate cortex ; SFG, superior frontal gyrus ; SMA, supplementary motor area ; SMG, supramarginal gyrus ; vmPFC, ventromedial prefrontal cortex; WOF, wheel of fortune.

#### 2.1.3.3.1 Reward reactivity during anticipation : the motivational impact of rewards

During the reward anticipation phase, a valuation process takes place and constitutes one of the core processes promoting the implementation of consecutive motivated behaviors (Bissonette & Roesch, 2016; Kurniawan, 2011). This valuation process includes the encoding of the motivational salience and motivational valence of an incentive stimulus (Madan, 2013). Enhanced activation within brain regions responsive to the salience and valence of a predicted reward after the presentation of an informative cue is thought to reflect the motivation to work for getting the predicted reward (Bissonette & Roesch, 2016). The anticipation of a more valued reward results in stronger motivation which might result in increased effort mobilized, attention and performance (Roesch & Olson, 2007). Therefore, the motivational drive for reward in behavioral experiments has often been measured by the extent of mobilized effort to obtain a reward after the presentation of a reward-related cue (K. C. Berridge, 2009b; Pool et al., 2016). In the last decade, several whole-brain meta-analyses were conducted in healthy humans to explore the neural correlates of the reward processing. As described in Table 2.1, these meta-analytic studies evidenced the critical implication of the NAcc, ACC and PFC during the reward anticipation among studies using different types of rewards and experimental tasks (for meta-analytic reviews see: Bartra, McGuire, & Kable, 2013; Diekhof et al., 2012; Xun Liu et al., 2011; see also Table 2.1). Additional regions consistently recruited during the reward anticipation included the anterior insula, the supplementary motor area (SMA), and the brainstem (Hassan & Benarroch, 2015; Schultz, 2016; Schultz et al., 2017).

Two meta-analyses looked more specifically at the neural correlates implicated in the processing of monetary reward during the MID task, an instrumental-reward task widely used in humans (Oldham et al., 2018; Wilson et al., 2018). Data suggest that the anticipation of monetary rewards recruits mainly the NAcc, caudate nucleus, occipital regions, amygdala, SMA, thalamus, midbrain and cerebellum (for meta-analytic reviews see: Oldham et al., 2018; Wilson et al., 2018). Nevertheless, caution must be used when trying to generalize findings from meta-analytic reports based on the use of a specific experimental task such as the MID task. Since the MID task implicates monetary incentives and instrumental actions for obtaining or avoiding to lose money, these findings should be interpreted keeping in mind that these neural substrates might be specific to the processing of more abstract rewards that are contingent upon performance. Also, if the studies reported by these two meta-analyses diverge slightly about the brain regions engaged during the MID task, it might be due to the use of different versions of this task.



## A. Neural correlates engaged in the encoding of the motivational salience and valence of rewards

Findings are essentially consistent across meta-analytic studies that support the recruitment of the ventral striatum, the vmPFC/OFC, the anterior insula, the ACC, the midbrain, and the SMA in the encoding of the reward value (for reviews see: Bartra et al., 2013; Diekhof et al., 2012; Xun Liu et al., 2011). In line with these meta-analyses, considerable evidence in humans demonstrated the role of the ventral striatum in the representation of the subjective reward value notably during anticipation (Kable & Glimcher, 2007; Peters & Büchel, 2011). Actually, it was suggested that the recruitment of the ventral striatum might not represent the encoding of the subjective value *per se*, but rather the weighted value once the cost has been taken into account such as for instance the delayed compared to the immediate delivery of the reward (Peters & Büchel, 2011). In other words, the ventral striatum might signal the subjective reward value and the cost or effort necessary to expend for obtaining the rewarding outcome.

With respect to the dorsal striatum, the caudate nucleus and the putamen have been preferentially involved in the encoding of the motivational salience of rewards. Specifically, the caudate nucleus is thought to play a determinant role in guiding motivated behaviors in humans, in particular when the reward delivery is contingent upon behavior or performance (Grahn, Parkinson, & Owen, 2008). The putamen has been implicated in the planning and the implementation of actions, as well as in habit formation (Everitt & Robbins, 2013; Schwabe, Wolf, & Oitzl, 2010). The caudate nucleus might be responsible for the selection of appropriate action schemas based on the evaluation of action-outcome associations, while the putamen governs habits and automatized behaviors that are more restricted to stimulus-response associations (Grahn et al., 2008).

Functionally connected to the substantia nigra, VTA, amygdala, thalamus and ACC (Menon, 2011), the role of the anterior insula was evidenced in the processing and integration of interoceptive signals (Craig, 2009; Gu, Hof, Friston, & Fan, 2013), in emotional awareness (Gu et al., 2013), and in detecting emotional motivational salience (Menon, 2011). Alerting signals sent from the thalamus might converge with the interoceptive information sent by the anterior insula to influence the integration of the reward value in the ventral striatum and the vmPFC/OFC (Cho et al., 2013). However, the engagement of the NAcc and the anterior insula was consistently demonstrated during the encoding of a variety of both positive and negative incentives (Bartra et al., 2013; Diekhof et al., 2012; Xun Liu et al., 2011). Since the NAcc received DAergic projections from the SNc and the VTA, this region is probably involved in the encoding of both the motivational salience and valence of rewards (Hassan & Benarroch, 2015; Schultz, 2016).

## B. Neural correlates engaged in the encoding of reward magnitude

Another important aspect when processing the reward value consists in tracking its magnitude. As described in Table 2.2 below, a meta-analytic study in humans reported that the reward magnitude is processed essentially by the ventral striatum, the ACC and the occipital cortex during the reward anticipation (Diekhof et al., 2012).

Table 2.2

*Neural correlates implicated in the processing of reward magnitude during the anticipation and delivery of rewards*

Phase	Number of studies	Tasks	Reward valence		Neural correlates of reward magnitude
			Positive incentives	Neutral/negative incentives	
Anticipation	24	Reward passive task (e.g. delivery of sweet taste or food-related odor), Performance-dependent tasks (e.g. MID task), Decision making reward tasks (e.g. gambling task with rewards and penalties).	Monetary win, sweet taste or odor, viewing of happy faces.	Monetary loss, aversive taste or odor.	ACC Occipital cortex Ventral striatum
Delivery	47	Reward passive task (e.g. delivery of sweet taste or food-related odor), Performance-dependent tasks (e.g. MID task), Decision making reward tasks (e.g. gambling task with rewards and penalties).	Monetary win, sweet food-related odor, high- or low-fat drink, tasty drink viewing of attractive faces.	Monetary loss, aversive food-related odor, tasty drink viewing of neutral faces.	Frontopolar cortex Mid occipital Precuneus Putamen Ventral striatum vmPFC VTA Thalamus

*Note.* Adapted from the findings presented in the meta-analysis of Diekhof and colleagues (2012). ACC, anterior cingulate cortex ; MID, monetary incentive delay; vmPFC, ventromedial prefrontal cortex; VTA, ventral tegmental area.

With the aim of understanding the different neural substrates and their functions during the reward processing, experimental tasks were developed to parse the processes implicated during the anticipation and delivery of positive outcomes. The next section covers the recent advances and findings documented on the neural correlates of reward delivery, on whether primary and secondary rewards recruit different or common brain circuits, and on how these neural mechanisms are related to actual subjective feelings of pleasantness experienced during the reward delivery.

#### 2.1.3.3.2 Reward reactivity during delivery : the hedonic impact of rewards

The mapping of brain circuitry involved in pleasure causation began with research in animals. It helped elaborate upon the brain substrates engaged in the processing of positive hedonic rewards. As discussed in the section 2.1.3.2, pharmacological and single-unit studies in animals contributed widely to map the specific anatomical hotspots implicated in hedonic reactions and to evidence the determinant role played by the neurotransmission of opioids and endocannabinoids in these specific anatomical sites for generating pleasure during the consumption of primary rewards (for reviews see: K. C. Berridge & Kringelbach, 2015; Kringelbach & Berridge, 2017). In animals, the experience of pleasure has been largely explored by measuring the orofacial affective expressions of hedonic reactions elicited by the consumption of sweet tastes (K. C. Berridge & Kringelbach, 2015). These orofacial affective expressions are usually characterized by rhythmic tongue protrusions and lateral lip licking to sweetness compared to gapes and headshakes elicited by bitterness (Steiner et al., 2001).

Taken together, animal studies evidenced the implication of the NAcc (e.g. Roitman et al., 2010; Taha, 2005) and the OFC (e.g. Burton, Kashtelyan, Bryden, & Roesch, 2014) in encoding the reward value and its magnitude during the receipt, while the OFC is also critically affected by temporal delay in reward delivery (e.g. Burton et al., 2014). The delay in reward delivery might devalue the actual value attributed to the reward whose delivery was delayed, as reflected by decreased activations of OFC neurons. Finally, findings in animals demonstrated the role of the ACC in adapting consecutive behaviors, notably by encoding the value of other potential options that were not chosen (e.g. Hayden, Pearson, & Platt, 2009). Recent comparative studies converge to indicate that the neural circuitry underpinning hedonic reactions in humans is very similar to that of rodents and non-human primates (K. C. Berridge & Kringelbach, 2008). Based on the knowledge acquired from animal data, we cover here after the neuroimaging studies in humans that investigated which brain regions might contribute to the experience of pleasure and how the activation in brain regions known to be implicated in hedonic reactions was related to the evaluation of subjective pleasantness.

##### A. Neural correlates engaged in the encoding of reward magnitude during the delivery phase

In line with animal data (Burton et al., 2014; Roitman et al., 2010; Taha, 2005), a tremendous amount of studies evidenced the critical role played by the vmPFC/OFC and the NAcc in the representation of reward value during the outcome delivery (Grabenhorst & Rolls, 2011; Levy & Glimcher, 2012; Peters & Büchel, 2011; Sescousse et al., 2013). Specifically, these regions are in

charge of encoding the reward magnitude during the delivery of pleasurable outcomes (Diekhof et al., 2012; see Table 2.2).

#### B. Neural correlates engaged in the encoding of different types of reward during the delivery phase

Whether the processing of different types of reward engages common or distinct brain substrates is a determinant question to understand the role played by neural substrates during the encoding of reward. A wealth of data has demonstrated that an overlapping reward circuitry processes different types of pleasurable outcomes when delivered, including food, sex, drugs of abuse, money, social relationships, music or art (Bhanji & Delgado, 2014; Blood & Zatorre, 2001; Izuma, Saito, & Sadato, 2008; Rademacher et al., 2010; Saxe & Haushofer, 2008; Simon et al., 2015; Tang, Fellows, Small, & Dagher, 2012). This “common reward circuit” comprised essentially the NAcc, the vmPFC/OFC, the anterior insula, the amygdala and the mediodorsal thalamus (Sescousse et al., 2013; see Table 2.3 for more detailed results). In line with these findings, the receipt of monetary rewards engaged preferentially the NAcc, vmPFC/OFC, amygdala, and PCC as assessed during the MID task (for a meta-analytic review see: Oldham et al., 2018). Interestingly, the vmPFC/OFC and the NAcc were recruited significantly more during the processing of monetary rewards in comparison with food or erotic rewards, suggesting that these regions are specifically involved in the processing of more abstract rewards implicating higher-order processes (Sescousse et al., 2013). Taken together, the encoding of rewards during the outcome delivery mobilizes both a similar “core reward system” and distinct brain regions that are dedicated to rewards of a specific nature (see Table 2.3).

Table 2.3

*Neural correlates implicated during the delivery of monetary, food, and erotic rewards reported in the meta-analysis of Sescousse et al. (2013) on 87 fMRI studies*

Types of reward	Tasks	Neural correlates during the reward delivery	Contrasts between reward types
			<i>Monetary &gt; food and erotic</i>
Monetary	e.g. MID task, number guessing task ; gambling tasks (e.g. slot machine, WOF task) ; guessing tasks (e.g. number, card), target detection task ; reversal learning task.	aINS Amygdala Mediodorsal thalamus NAcc vmPFC/OFC	vmPFC/OFC NAcc
			<i>Food &gt; monetary and erotic</i>
Food	e.g. passive delivery task ; choice preference task ; classical conditioning task.	aINS Amygdala Mediodorsal thalamus NAcc vmPFC/OFC	/
			<i>Erotic &gt; monetary and food</i>
Erotic	e.g. passive viewing task with or without a concurrent cognitive task ; choice preference task ; delay and effort discounting task ; erotic incentive delay task.	aINS Amygdala Mediodorsal thalamus NAcc vmPFC/OFC	Amygdala

*Note.* aINS, anterior insula ; MID, monetary incentive delay; NAcc, nucleus accumbens ; OFC, orbitofrontal cortex; vmPFC, ventromedial prefrontal cortex ; WOF, wheel of fortune.

### C. Neural correlates engaged in the encoding of the subjective feeling of pleasantness

Last but not least, a critical question is whether the neural correlates implicated in the reward delivery do reflect the subjective feeling of pleasantness experienced during the receipt or consumption of a reward. As expressed by Berridge and Kringelbach (2015, p. 649), “ there is a difference between how people feel and report subjectively versus how they objectively respond with neural or behavioral affective reactions ”. In a recent meta-analysis conducted on 40 studies, the subjective feeling of pleasantness experienced during the reward receipt and assessed with self-reported ratings of attractiveness, feeling of liking, or beauty correlated positively with increased activation in the medial OFC, vmPFC, ventral striatum, thalamus and the mid ACC (for a review see: Kühn & Gallinat, 2012). These findings suggest that the subjective feeling of pleasantness is directly associated with the neural substrates implicated during the reward delivery. The subjective feeling of pleasantness is related to the subjective value attributed to the reward and depends upon the temporal delay of the reward delivery (for reviews see: Frost & McNaughton, 2017; Peters & Büchel, 2011), as showed for instance by the significant decreased reactivity in reward-related

regions including the NAcc, mOFC, PCC and ACC in response to delayed palatable rewards (e.g. McClure, Ericson, Laibson, Loewenstein, & Cohen, 2007) and to monetary gains (e.g. Ballard & Knutson, 2009; de Water et al., 2017; McClure, 2004).

Figure 2.7 summarizes the brain regions consistently involved during the reward anticipation and the reward delivery, as reported by the meta-analyses in humans discussed in this section. Specifically, it describes the neural correlates of the motivational salience and of the motivational valence during the reward anticipation, and of the hedonic reactivity (i.e. representation of the subjective reward value) and of the feeling of pleasantness during the reward delivery.

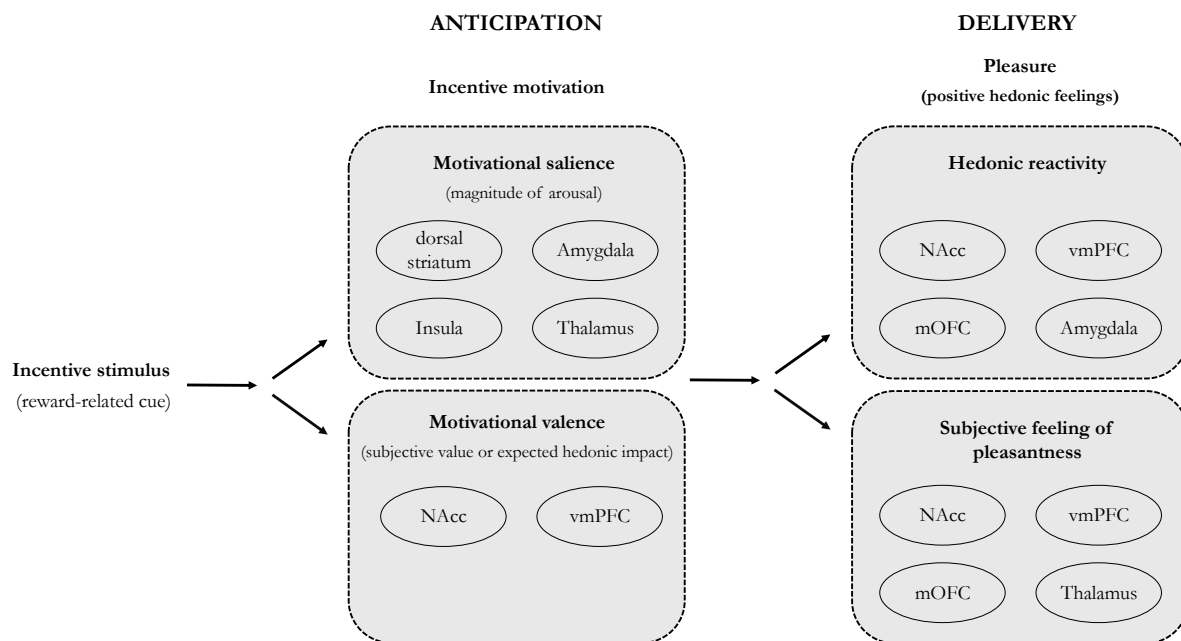

Figure 2.7. Illustration of the neural correlates involved during both the reward anticipation and the reward delivery based on meta-analyses in humans. During reward anticipation, brain regions involved in the encoding of motivational salience and of motivational valence are described. During reward delivery, brain regions engaged in the encoding of the hedonic reactivity (i.e. representation of the subjective reward value) and those implicated in the feeling of pleasantness experienced during reward receipt. mOFC, medial orbitofrontal cortex; NAcc, nucleus accumbens; vmPFC, ventromedial prefrontal cortex.

#### 2.1.4 Summary

To sum up, a reward describes the positive value that someone ascribes to an object, a behavioral action, or an internal physical or affective state (Schultz, 1997; Wise, 2004). In the present thesis, the concept of reward processing integrates the contributions made by behavioral learning theories and by the research in affective neuroscience. Positive value is attributed through associative and instrumental learning processes, i.e. the learning component of the reward processing (Kringelbach & Berridge, 2010). The positive emotion elicited by a reward is labeled hedonic reaction or pleasure, and constitutes the affective component of the reward processing (K. C. Berridge & Kringelbach, 2015). As evidenced in animal studies (e.g. Castro & Berridge, 2014; Mahler et al., 2007; Pecina & Berridge, 2005), the generation of hedonic reactions is essentially localized in brain centers called hedonic hotspots in combination with the stimulation of their opioid and endocannabinoid neurochemical receptors. Through associative and instrumental conditioning, the prediction of a positive consequence will foster motivated behaviors to expend efforts for it to occur (K. C. Berridge et al., 2009; Dayan & Balleine, 2002; Dickinson & Balleine, 1994). In other words, a reward acts as a positive reinforcer enhancing approach behaviors. Mainly centered on the midbrain DAergic neurons, the motivational component involves the encoding of the motivational valence and motivational salience of both appetitive and aversive signals (Boekhoudt et al., 2018; Hassan & Benarroch, 2015; Schultz, 2017). Therefore, the midbrain DAergic neurons and the regions receiving their DAergic projections constitute a key candidate for understanding the motivational mechanisms at the interplay between the reward and stress systems, resulting respectively in approach and avoidance behaviors.

In this framework, human studies demonstrate that the anticipation of positive outcomes involves mainly the ventral and dorsal striatum, anterior insula, ACC, prefrontal and occipital regions, SMA and the brainstem (Bartra et al., 2013; Diekhof et al., 2012; Xun Liu et al., 2011). When monetary rewards are at stake, the reward anticipation recruits mainly the amygdala, the dorsal striatum, the NAcc, and the thalamus during the MID task (Oldham et al., 2018; Wilson et al., 2018). This valuation system centered on the striatum is recruited for encoding the motivational salience and the valence of predicted rewards. In particular, the NAcc has been consistently involved in the encoding of the motivational salience and valence of predicted outcomes. The NAcc might inform the dorsal striatum about the motivational value of the predicted outcome, resulting in the maintenance of reward-related goals and the implementation of reward-seeking behaviors (O'Doherty, 2004a). Among others, the striatal regions might play a critical role in our ability to predict and evaluate the salience and valence of positive and negative incentives during the anticipatory phase. This ability is necessary for implementing relevant reward-seeking

behaviors. This requires in particular (i) the integration of sensory information coming from incentives, (ii) the convergence between sensory information and cognitive processes to elaborate goal-driven plans, and (iii) the selection, implementation and control of motor actions (Haber, 2011). During the receipt of positive outcomes, the vmPFC/OFC and the NAcc are two key regions recruited for integrating the subjective reward value and for translating this hedonic value into cognitive representations (Dickinson & Balleine, 1994; Kringelbach, 2003, 2005). These findings help to build up a better understanding of the neural substrates implicated specifically during the motivational and affective components of the reward processing. Therefore, delineating the normal and adaptive processes implicated during the reward processing might contribute to open new avenues for prevention and treatment of disorders marked by an alteration of the reward function. A major question tackled in the present thesis is how do exposure to acute stress, and various levels of cognitive load affect reward responsiveness. In this framework, we discuss in the next section the existing literature on the role played by acute stress and cognitive effort during the reward processing.



## **2.2 FACTORS AFFECTING REWARD PROCESSING : FOCUS ON STRESS AND COGNITIVE EFFORT**

The ability to detect, to pursue, and to react to beneficial rewards can sometimes compete with the avoidance of aversive or damaging consequences (Haber & Knutson, 2010). The role of disrupted reward responsiveness and stress reactivity in the development of mental disorders is well-documented (e.g. E. K. Adam et al., 2017; Kerestes et al., 2014; Lopez-Duran, Kovacs, & George, 2009; Martin-Soelch et al., 2001; G. P. Strauss, Waltz, & Gold, 2014; Zorn et al., 2017). Recent findings evidenced that neural responsiveness to rewards was altered by stress (e.g. Dillon et al., 2014; Ironside, Kumar, Kang, & Pizzagalli, 2018; Pool, Brosch, Delplanque, & Sander, 2015), suggesting that the interaction between reward processing and stress exposure might constitute a promising vulnerability factor for the development of psychopathological symptoms. In this framework, the first aim of this thesis is to explore how the exposure to an unpredictable acute stressor influences the healthy adults' propensity to engage in motivated behaviors during the reward anticipation and to manifest hedonic responsiveness during reward delivery. The second aim of this thesis is to investigate how cognitive effort manipulated by variable levels of cognitive load modulates the effects of stress exposure on reward processing in healthy adults. In the present section, we discuss therefore the current state of literature documenting the effects of these two influencing factors on the reward processing in healthy adults.

### **2.2.1 Effects of stress exposure**

#### **2.2.1.1 Stress, stressor and psychological reactions to stressors**

The definitional boundaries of “stress” are closely linked to the concept of “homeostasis” formulated by Walter Bradford Cannon (1929) to describe the dynamic mechanisms that maintain the stability of a body's internal environment, including parameters around a critical set point that allows it to survive. Later, Hans Selye (1976) coined the word “stressor» to define the causal agent, while keeping “stress” for the resulting reactions. A stressor constitutes an environmental threat toward a major goal including the maintenance of one's physical integrity (physical stressor) (Rodrigues, LeDoux, & Sapolsky, 2009), or in other terms, “real or perceived challenges to an organism's ability to meet its real or perceived needs” (Greenberg, 2002, p. 508). A stressor is characterized by the nature of its threat (e.g. physical, psychosocial), its duration (e.g. acute or chronic), its predictability (unpredictable/predictable), and its controllability (uncontrollable/controllable) (Cabib & Puglisi-Allegra, 1996; Pacák & Palkovits, 2001). In response to stress exposure, stress reactions describe the set of physiological, neural,

behavioral and psychological responses that are evoked to cope with the challenging situation (McEwen, 2007; McEwen & Wingfield, 2010). Among psychological reactions to stressors, fear and anxiety are two major emotional states elicited under stress exposure (for a review see: Shin & Liberzon, 2010). Both are characterized by the recruitment of distinct physiological and neural substrates resulting in differentiated behavioral reactions and emotional states (LeDoux & Pine, 2016). Fear reflects an adaptive state elicited by imminent stressors, resulting in an immediate reaction of immobility (e.g. freezing, hypervigilance) or in defensive reactions (e.g. fight-or-flight) (Adolphs, 2013; Lang et al., 2000; Schmitz et al., 2011). The fight-or-flight response was coined by Cannon (1932) to describe the physiological and behavioral reactions elicited by the exposure to acute immediate stressor (for a review see: McEwen, 2007). In contrast, a state of anxiety is characterized by sustained hypervigilance and hyperarousal together with recurrent worries and ruminations caused by uncertain and unpredictable stressors or by more distant dangers (Davis, Walker, Miles, & Grillon, 2010, p. 20; Schmitz et al., 2011; Sylvers, Lilienfeld, & LaPrairie, 2011). A state of anxiety mainly related to avoidance and higher sensory sensitivity is called sustained fear (Grillon, 2008). In the present thesis, fear and a state of anxiety are considered as the psychological responses that reflect distinct stress responses, respectively to an immediate stressor of short duration, and to a prolonged, diffuse or unpredictable/uncontrollable stressor. In this framework, this thesis also looks at how stress exposure leading to a state of anxiety affects the reward processing in healthy adults. Specifically, the question is how approach and avoidance systems interact to promote adaptive or maladaptive behaviors in humans.

#### 2.2.1.1.1 Rationale to focus on unpredictable and uncontrollable acute stress

In the present work, we aimed at investigating how a state of anxiety induced by an acute unpredictable and uncontrollable stressor affects reward processing in humans. An acute stressor refers to a time-limited threat that might occur once or continuously over a short time (Pacák & Palkovits, 2001). In order to induce a sustained physiological stress reaction and a state of anxiety, we administered unpredictable mild electric shocks, a procedure called also threat-of-shock. The rationale for using uncontrollable and unpredictable mild electrical shocks to induce a sustained state of anxiety was threefold. First, an uncontrollable and unpredictable stressor involves respectively (i) a threatening context of forced failure resulting in a feeling of loss of control and helplessness (T. C. Adam & Epel, 2007; Kemeny, 2003), and (ii) the inability to predict or anticipate the onset or termination of the stressor resulting in a state of anxiety (Foa, Zinbarg, & Rothbaum, 1992; Koolhaas et al., 2011; O. J. Robinson, Vytal, Cornwell, & Grillon, 2013), as demonstrated in rodents (see for a review: Koolhaas et al., 2011) and in humans (Davis et al., 2010; Mineka &

Kihlstrom, 1978; Ulrich-Lai & Herman, 2009). Second, the administration of mild electric shocks is a well-validated and reliable procedure to induce a physiological stress response in fMRI environment (for reviews see: Kogler et al., 2015; Schmitz & Grillon, 2012; Walker, Miles, & Davis, 2009). Third, contrary to psychosocial procedures such as the Montreal Imaging Stress Task (MIST) (Dedovic et al., 2005), the use of a physical stressor does not require to manipulate the feedback on performance which was an important prerequisite to manipulate orthogonally stress and reinforcement conditions. Before turning our attention to the neurobiological substrates of the stress system, the next section focuses on the different types of experimental procedures developed over the past decades for measuring physiological and behavioral reactions to stress exposure.

### **2.2.1.2 Experimental procedures to induce acute stress**

In experimental settings, acute laboratory stressors were defined as experimental tasks lasting one hour or less with the manipulation of a threat which is specific to the laboratory setting (Dickerson & Kemeny, 2004). In other words, an acute stressor refers to a time-limited threat that might occur once or continuously over a short time (Pacák & Palkovits, 2001). Physical and psychosocial stressors are the major laboratory stressors used to manipulate stress responses. In experimental settings, physical stressors include for instance the administration of electric shocks (for a review see: Grillon & Ameli, 1998), cold-pressor test (CPT; Lovallo, 1975), burst of white noise (e.g. Xinxin Liu, Iwanaga, Shimomura, & Katsuura, 2007), or single inhalation of carbone dioxide (CO<sub>2</sub>) (for a review see: Amaral, Spadaro, Pereira, Silva, & Nardi, 2013) to induce reliably a physiological stress response including the increase in cortisol and noradrenalin release (Dickerson & Kemeny, 2004; Kogler et al., 2015).

Another type of tasks deals with psychosocial stressors by combining a cognitive component (e.g. mental arithmetic) to a socio-evaluative component (e.g. negative performance feedback). So far, the gold standard procedure designed with a psychosocial stressor is the Trier Social Stress Test (TSSST; Kirschbaum, Pirke, & Hellhammer, 1993) where participants have to perform a speech and a mental arithmetic task in front of evaluators (socio-evaluative component). Other experimental procedures using a psychosocial stressor include the Maastricht Acute Stress Test (MAST; Smeets et al., 2012) and the Mannheim Multicomponent Stress Test (MMST; Reinhardt, Schmahl, Wüst, & Bohus, 2012). More specifically designed for being applied in fMRI environment, the MIST (Dedovic et al., 2005) is a well-validated stress procedure including a series of computerized arithmetic tasks with a social-evaluative component (i.e. performance indicators, one showing the participant's performance and one showing the average performance among all participants) and an induced failure component (i.e. time pressure).

Of particular importance for the empirical works presented in this thesis, our experimental task included the administration of electric shocks (i.e. physical stressor) to induce a physiological stress response including notably the increase in cortisol release.

#### 2.2.1.2.1 Measures of experimental stress induction

In laboratory and fMRI environments, measures for assessing the reliable induction of the stress manipulation comprise the assessment of the salivary cortisol concentration (for reviews see: Gunnar, Talge, & Herrera, 2009; Kudielka, Hellhammer, & Wüst, 2009), alpha amylase concentration (e.g. van Stegeren, Wolf, & Kindt, 2008), startle reflex (for a review see: Schmitz et al., 2011), and the heart rate (for reviews see: Allen, Kennedy, Cryan, Dinan, & Clarke, 2014; Campbell & Ehlert, 2012). Beside measures assessing the physiological stress reaction, subjective stress ratings are used to evaluate the state of anxiety and the feeling of being “stressed, tensed” during the exposure to the experimental stressor (Allen et al., 2014; Campbell & Ehlert, 2012; Dedovic et al., 2005; Smeets et al., 2012). Since the assessment of salivary cortisol level is nowadays a gold standard in laboratory and fMRI environment (for a review see: Bali & Jaggi, 2015), we measured the salivary cortisol concentration together with self-reports of mood and stress levels to evaluate the effect of stress induction on both the physiological stress reaction and the subjective feelings. Specifically, cortisol is the major stress hormone released by the hypothalamic-pituitary-adrenal (HPA) axis as discussed in the next section (McEwen, 1998; Papadimitriou & Priftis, 2009). In laboratory settings, the salivary cortisol concentration was reported to peak after the onset of a social-evaluative stressor in healthy humans, with a delay of 20 to 40 minutes in studies reported by Dickerson & Kemeny (2004), 15 to 20 minutes after the onset of the social-evaluative and physical stressors in studies reported by Kudielka and colleagues (2009), while the peak reported by Goodman et al. (2017) occurred between 35 and 45 minutes after the start of a psychosocial stressor. In laboratory settings, the salivary cortisol concentration returns usually to its initial level by 40-60 minutes after the stressor cessation (Dickerson & Kemeny, 2004). As reflected by the inconsistent time intervals approximated by literature reviews (Dickerson & Kemeny, 2004; W. K. Goodman et al., 2017; Kudielka et al., 2009), salivary cortisol responses show large intra-individual and inter-individual variability, making the identification of the mechanisms involved in the biological stress responses more complex (Kudielka et al., 2009). For instance, gender plays a critical role in the activation of the HPA system under stress with consistent strengthened salivary cortisol response demonstrated in healthy men compared to healthy women (i.e. between puberty and menopause) after experimental acute stress exposure (for a review see: Kajantie & Phillips, 2006). Age effects on the cortisol concentration are less consistent, with data suggesting (i) no or

weak age-related influences, (ii) strengthened cortisol response in children and young adults compared to elderly, (iii) a trend elevation of cortisol concentration in elderly men and women (for a review see: Kudielka et al., 2009). Beside the physiological reactivity, experimental stressors heighten self-reported stress and state of anxiety as well as negative mood (for reviews see: Allen et al., 2014; Campbell & Ehlert, 2012). In the next section, we discuss in more details how stress is processed in the brain and the neuroendocrine systems implicated in stress reactions, in particular in response to the procedures detailed above.

### **2.2.1.3 Stress processing in the brain and neuroendocrine reactions to stress exposure**

When an organism suddenly experiences an immediate threat, the rapid activation of the autonomic nervous system (ANS) comes into play within seconds to mobilize bodily resources to deal with the stressor (Kemeny, 2003). The sympathetic response of the ANS to immediate stressors activates the sympatho-adrenomedullary (SAM) system leading to the release of epinephrine (also known as adrenaline) and norepinephrine (or noradrenaline) (Greenberg, 2002; Hale & Lowry, 2015). The secretion of norepinephrine from sympathetic nerves located in the central nervous system (CNS) stimulates the adrenal medulla resulting in the release of epinephrine into the blood flow (Kemeny, 2003). Described by Cannon (1932) as the fight-or-flight response, the release of epinephrine and norepinephrine fosters the preparation and mobilization of resources by increasing metabolic activity as for instance increased heart rate, higher blood flow to supply the adequate amount of oxygen, or orienting blood flow toward the muscles (Bartlett, 1998). In the CNS, stress reactions to an immediate threat involves the activation of the basolateral amygdala which projects mainly to the hypothalamus and brainstem via the medial division of the central nucleus of the amygdala, as demonstrated in rodents (Davis et al., 2010).

In conjunction with the ANS, the HPA system plays a key role in the stress response, specifically when the challenging situation is prolonged, uncontrollable and/or unpredictable (Goldstein, 1990; Szabo, Tache, & Somogyi, 2012). The activation of the HPA axis unfolds over minutes as compared to the ANS which comes into force over seconds (Kemeny, 2003). The activation of the HPA axis initiates the release of the corticotrophin releasing hormone (CRH) and arginine vasopressin (AVP) from the paraventricular nucleus (PVN) of the hypothalamus in the CNS (Hale & Lowry, 2015). The release of CRH and AVP stimulates the release of adrenocorticotrophic hormone (ACTH) by the pituitary gland (Goncharova, 2013). The ACTH is transported through the blood flow to the adrenal cortex (external layer of the adrenal gland) to stimulate the release of glucocorticoids including the cortisol hormone (Goncharova, 2013; Kemeny, 2003). The secretion of cortisol is adaptive on a short duration as it promotes the increase

in metabolic activity for dealing with the stressor (Hale & Lowry, 2015). After stressor cessation, a self-controlling feedback system including a negative feedback loop of cortisol arriving at the pituitary gland and hypothalamus in the CNS occurs in order to turn off the ANS and HPA (Lovallo & Thomas, 2017; McEwen, 1998; see Figure 2.8).

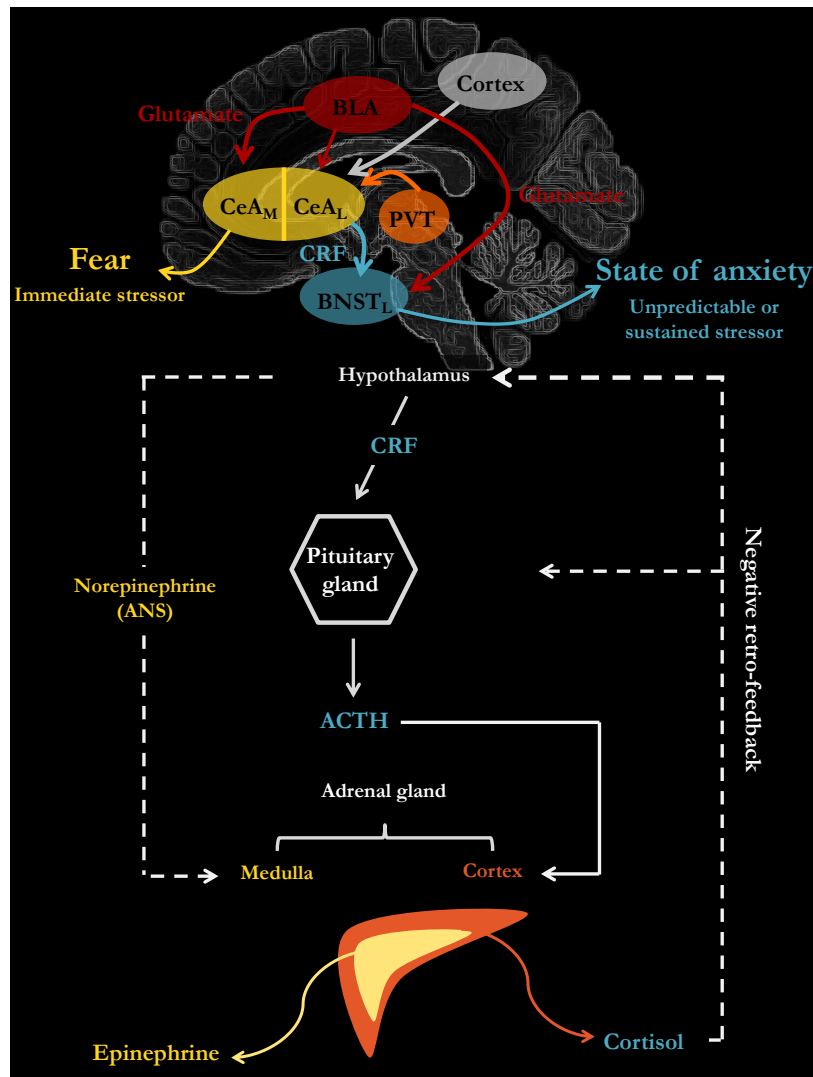

Figure 2.8. Illustration of the biological and neural systems involved in the stress reaction characterizing the psychological responses of fear and anxiety. These systems include the Autonomic Nervous System (ANS) and the hypothalamic-pituitary-adrenal (HPA) system. When an acute stressor is perceived, ANS activation leads to the release of norepinephrine from the nervous system which in turn stimulates the adrenal medulla leading to the release of adrenaline into the blood flow. This first response reflect the fight-or-flight response associated with fear. Together with the ANS, the HPA is engaged when the stressor is sustained or unpredictable. HPA activation results in the secretion of the corticotrophin releasing hormone (CRH) from the hypothalamus. The release of CRH stimulates the release of adrenocorticotrophic hormone (ACTH) by the pituitary gland, which stimulates the release of the cortisol hormone in the blood flow. In sum, aversive events might rapidly activate the basolateral amygdala (BLA) which projects to the medial division of the central amygdala (CeA<sub>M</sub>) leading to a fear response. Simultaneously, CRF-containing projections sent from the BLA to the lateral division of the central amygdala (CeA<sub>L</sub>) result in the release of CRF sent to the lateral division of the BNST (BNST<sub>L</sub>) resulting in a sustained state of anxiety. This figure was adapted from Hale & Lowry (2015, p. 22) and from Davis et al. (2010, p. 121).

Animal studies contributed to our understanding of brain regions involved in the stress reactivity, notably by evidencing that glucocorticoids receptors were present in high densities in the hippocampus and the amygdala of rodents (McEwen, Weiss, & Schwartz, 1968) and monkeys (Sánchez, Young, Plotsky, & Insel, 2000). In rodents, the exposure to prolonged, unpredictable and/or uncontrollable threats was shown to trigger the secretion of CRF into the bed nucleus stria terminalis (BNST) via the projections from the lateral division of the central nucleus of the amygdala in the CNS (Walker & Davis, 2008; Walker et al., 2009).

In humans, recent research evidenced the role of regions of the limbic system in the regulation of the HPA axis. During the sustained anticipation of threat-of-shock, both the medial division of the central nucleus of the amygdala and the BNST communicated less strongly with the vmPFC, the cingulate cortex, and the NAcc (Torrissi et al., 2018). In sum, the amygdala recruitment was shown to strengthen HPA activation resulting in increased cortisol release, whereas the activation of the ACC, the medial prefrontal cortex (mPFC) and hippocampus plays a key role in the inhibition of the HPA activation (Herman, Ostrander, Mueller, & Figueiredo, 2005; Kovács, 2013).

In line with these results, the exposure to an acute stressor was related to increased activity and communication of regions within the salience network (i.e. amygdala, anterior insula, dACC, and temporal pole) and the default mode network (i.e. mPFC, posterior cingulate cortex, precuneus, and inferior parietal lobule), while the negative feedback loop of cortisol was associated with the reallocation of neural resources to the central executive network (i.e. dorsolateral and dorsomedial PFC, dorsal posterior parietal cortex, and frontal eye field), contributing to the maintenance of the homeostasis (for reviews see: Hermans, Henckens, Joëls, & Fernández, 2014; van Oort et al., 2017; see Figure 2.9). Interestingly, some findings evidenced strengthened activation of regions located in the central executive network during exposure to an acute stressor when the task involved high-demanding cognitive effort (see for a review: Dedovic et al., 2009).

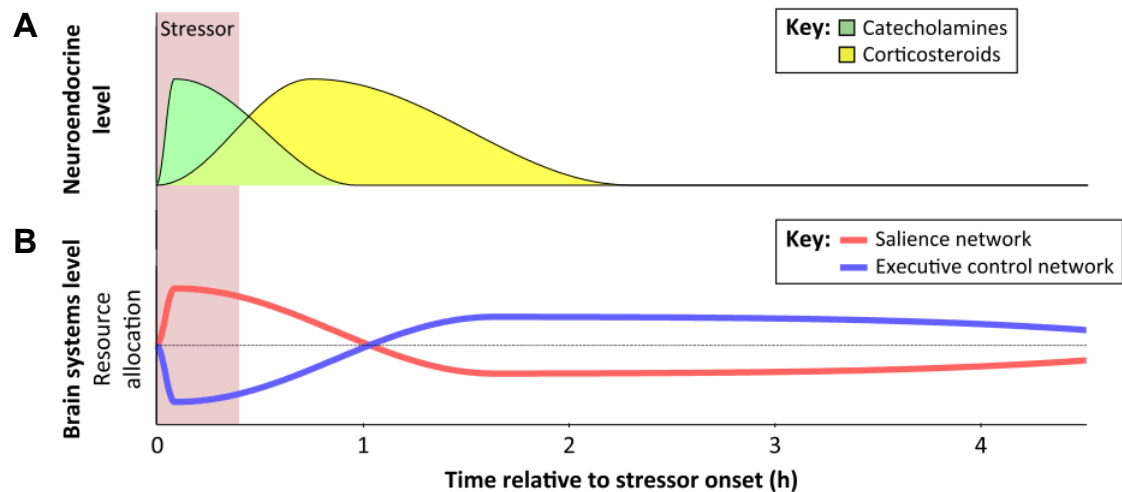

Figure 2.9. Biphasic-reciprocal model of reallocation of neural resources during the exposure to an acute stressor. Illustration of the effects of an acute stressor on (A) the release of stress hormones including catecholamines (e.g. epinephrine, norepinephrine and dopamine) and corticosteroids (e.g. cortisol), and (B) the activation of brain networks such as the salience network and the executive control network. Adapted from Hermans et al. (2014, p. 305).

#### 2.2.1.4 Behavioral and neural effects of acute stress on reward processing

The first aim of this thesis is to understand how stress exposure affects reward processing in healthy adults, in particular during reward anticipation (i.e. motivational component) and reward delivery (i.e. affective component). In this framework, we review here the behavioral and fMRI studies which started recently to investigate how stress exposure influences reward processing in humans. In behavioral studies, stress exposure was shown to reduce reward responsiveness by counteracting the reward-induced facilitation effect on performances (Berghorst, Bogdan, Frank, & Pizzagalli, 2013; Bogdan & Pizzagalli, 2006). By using threat-of-shock or negative performance feedback as stressors, Bogdan and Pizzagalli (2006) demonstrated, for instance, that the participants' propensity to act and perform better as a function of a potential anticipated reward was hindered by the exposure to acute experimental stress. Converging with these data, pharmacological injections of cortisol decreased self-reported responsiveness to reward, as reflected by lower self-reported motivation to obtain the reward in the stress condition compared to the control condition (Montoya, Bos, Terburg, Rosenberger, & van Honk, 2014). Similar to acute experimental stressors, the level of stress perceived in daily life modulated reward responsiveness, as demonstrated by the decreased propensity of participants to enhance their performance for obtaining a predicted reward (Pizzagalli, Bogdan, Ratner, & Jahn, 2007).

However, animal studies suggested that stress exposure can also strengthen motivation to obtain predicted rewards (for a review see: Ungless et al., 2010). In line with these animal data,



Pool and colleagues (2015) evidenced that the exposure to acute experimental stress (i.e. socially evaluated cold-pressor task) enhanced the propensity of healthy humans to mobilize effort for getting a reward (i.e. chocolate odor), whereas the subjective rating of pleasantness of the chocolate odor was not affected by stress exposure. Converging with behavioral data, emerging fMRI studies in humans have explored how reward processing is affected by the exposure to an experimental stress induction (Ernst et al., 2004; Kumar et al., 2014; Lewis, Porcelli, & Delgado, 2014; Montoya et al., 2014; Oei, Both, van Heemst, & van der Grond, 2014; Ossewaarde et al., 2011; Porcelli, Lewis, & Delgado, 2012), to daily life stress (Nikolova & Hariri, 2012; Pizzagalli et al., 2007; Treadway, Buckholtz, & Zald, 2013), and to early life adversity (Boecker et al., 2014; Dillon et al., 2009; Hanson, Hariri, & Williamson, 2015 see Table 2.4).

In the present work, we aimed at exploring more specifically the effects of an experimental acute stressor on the motivational and affective components during the reward processing. So far, only a few fMRI studies investigated how reward processing is influenced by the exposure to acute experimental stressors including physical stressors (e.g. threat-of-shock, cold pressor) (J. M. Choi, Padmala, Spechler, & Pessoa, 2014; Lewis et al., 2014; Porcelli et al., 2012), psychological stressors (e.g. aversive movie clips) (Ossewaarde et al., 2011), psychosocial stressors (e.g. negative performance feedback) (Kumar et al., 2014; Oei et al., 2014) or a combination of several types of stressors (Pool et al., 2015).

During the anticipatory phase, experimental stress decreased reward-related activation in the mPFC (Ossewaarde et al., 2011) and in the NAcc (Oei et al., 2014), while a study evidenced the link between early life adversity and reduced reactivity of the ventral striatum in response to reward cues (Boecker et al., 2014). The impairing effect of stress on the NAcc reactivity was also evidenced in a pharmacological study in which the injection of cortisol diminished the activation of the NAcc in all conditions, irrespective of predicted rewards (Montoya et al., 2014). In turn, other studies evidenced in contrast that the exposure to acute experimental stress enhanced the striatal reactivity to reward-related cues (Kumar et al., 2014; Lewis et al., 2014). For instance, stress induction increased reward-related activation in the caudate nucleus and the amygdala (Kumar et al., 2014). This is in line with research conducted in rodents which evidenced stronger DA release in the striatal regions under acute stress, leading to strengthened reward-oriented behaviors (for a review see: Joseph, Datta, & Young, 2003). Interestingly, the exposure to acute stress heightened the activation to cues predicting monetary reward of high magnitude in the ventral putamen, but only in high-responders (i.e. individuals with high cortisol responses to the stressor) (Lewis et al., 2014). Convergent with these findings, higher cortisol level was linked to stronger NAcc activation

in response to the subliminal presentation of sexual cues during the exposure to acute stress (Oei et al., 2014).

During the delivery phase, early life adversity was associated with decreased responsiveness to reward delivery in the NAcc (Hanson et al., 2015), while the exposure to an acute experimental stressor reduced reward responsiveness in the dorsal striatum including the caudate and putamen (J. M. Choi et al., 2014; Kumar et al., 2014; Porcelli et al., 2012), the thalamus (J. M. Choi et al., 2014; Kumar et al., 2014), the amygdala (Kumar et al., 2014), the anterior insula (J. M. Choi et al., 2014), the dACC (J. M. Choi et al., 2014), and the OFC (Kumar et al., 2014; Porcelli et al., 2012). Interestingly, stress induction decreased reward responsiveness in the dorsal striatum and the OFC, but only when the reward magnitude was low (Porcelli et al., 2012). Table 2.4 presents a non-comprehensive review of these studies that investigated the effect of experimental stress on the reward processing in healthy adults during the anticipation and delivery phases.

Taken together, these emerging findings suggest that the ventral striatum might be particularly sensitive to experimental stressors during both reward anticipation and reward delivery. Nevertheless, current results on the effect of experimental acute stress on the striatal responsiveness during the reward processing are still inconsistent, calling for replication. Although some data indicate that stress and the cortisol concentration reduce the reactivity of the ventral and dorsal striatum, other findings suggest in contrast that stress exposure strengthened the striatal responsiveness to predicted rewards. During the delivery phase, the literature evidenced a more consistent picture suggesting a stress-induced reduction of reward responsiveness in the ventral and dorsal striatum, as well as in the OFC. To date, the literature looking at the interplay between stress and reward is still limited. The inconsistent findings call for a better understanding of how stress exposure influences the reward processing. To fill in this gap, the main questions of the present thesis are (i) how does unpredictable acute stress modulate striatal responsiveness during reward anticipation and delivery, and (ii) how does the cognitive effort to exert for obtaining the reward interact with stress to modulate reward responsiveness. This brings up questions about the role played by cognitive effort during reward processing. The next section addresses this specific question together with the relationships linking the cognitive effort to reward and stress.

Table 2.4

*Overview of studies documenting the effects of stress on the reward processing in healthy adults*

Study	Year	Experimental task	Type of stressor	Measures of the manipulated variables		Phases			Main findings
				Stressor	Reward	Cue	Feed	Behavioral	
Bodgan & Pizzagalli	2006	Signal-detection task	Threat-of-shock Negative performance feedback	NA (PANAS)	Monetary			x	Reduced response bias to reward under stress exposure.
Pizzagalli et al.	2007	Signal-detection task	Daily life stressor	PSS	Monetary			x	Participants with higher PSS scores showed reduced response bias to reward and higher anhedonic symptoms.
Dillon et al.	2010	MID task	ELA (maltreatment)	AAI, TSS, rCTS	Monetary	x	x		Participants with stronger ELA showed reduced reactivity in the globus pallidus during reward anticipation. No stress-induced effect during reward delivery.
Ossewaarde et al.	2011	MID task	Aversive movie clips	Salivary cortisol, NA, HR frequency, HR variability	Monetary	x			Stress exposure decreased mPFC reactivity to cued rewards.
Nikolova et al.	2012	Card guessing task	Recent life stress	LESS	Monetary		x		Higher level of recent life stress is associated with lower positive emotions, but only in individuals with low NAcc activation.
Porcelli et al.	2012	Card guessing task	CPT	Salivary cortisol, stress rating	Monetary		x		Reduced responsiveness to reward delivery in the caudate nucleus, putamen, and OFC under stress exposure.
Berghorst et al.	2013	PSST	Threat-of-shock	Salivary cortisol, anxiety rating	Positive feedback			x	Reduced response bias to reward under stress exposure, but only in individuals with high cortisol levels.
Treadway et al.	2013	MID task	Recent life stressor	PSS	Monetary	x	x		The responsiveness to reward delivery in mPFC correlated negatively with PSS scores.
Boecker et al.	2014	MID task	ELA	ELAI	Monetary, positive feedback	x	x		Higher ELA resulted in (i) reduced reward reactivity during anticipation in the VS, putamen, and thalamus, and (ii) increased responsiveness during reward delivery in the aINS, pallidum, and putamen.

Study	Year	Experimental task	Type of stressor	Measures of the manipulated variables		Phases			Main findings
				Stressor	Reward	Cue	Feed	Behavioral	
Choi et al.	2014	MID task	Threat-of-shock	Skin conductance	Monetary		x		Reduced responsiveness to reward delivery in the midbrain/VTA, striatum, BNST, aINS, MFG, and dACC under stress exposure.
Kumar et al.	2014	MID task	Negative performance feedback	Skin conductance NA and PA	Monetary	x	x		Stress exposure increased reactivity to cued reward in the caudate nucleus and amygdala during anticipation, but decreased responsiveness to reward delivery in the caudate nucleus and putamen during feedback.
Lewis et al.	2014	Pavlovian conditioning task	CPT	Salivary cortisol Stress rating	Monetary	x			Stress exposure increased reactivity to CS predicting rewards of higher magnitude in the putamen, but only in individuals with higher cortisol levels.
Montoya et al.	2014	MID task	Cortisol administration	Salivary cortisol	Monetary	x			Compared to low cortisol dose, high cortisol dose led to (i) reduced NAcc activation in both rewarded and not-rewarded trials, (ii) increased RT in rewarded trials, and (iii) reduced subjective reward value.
Oei et al.	2014	Backward-masking paradigm	TSST	Salivary cortisol	Erotic pictures	x *			Stress exposure reduced NAcc reactivity to masked sexual stimuli, with cortisol levels mediating this relationship. Higher cortisol levels were associated with stronger NAcc activation.
Hanson et al.	2015	Card guessing task	ELA	LC	Monetary		x		Higher ELA resulted in reduced NAcc responsiveness to reward delivery.
Pool et al.	2015	PIT test	Socially evaluated CPT	Salivary cortisol, stress rating	Chocolate odor			x	Stress exposure increased the number of squeezes toward cued reward (CS+) during anticipation.

*Note.* The table describes the experimental task performed by the participants, type of stressor used to manipulate the stress response, measures to assess the manipulation of the stressor and reinforcement, phases of reward processing investigated with the cue phase referring to reward anticipation, the feed phase referring to feedback/reward delivery, and response bias to studies exploring the behavioral performance in relationship with the ability to modulate behavior as a function of reinforcement schedule. AA, alpha-amylase ; AAI, Adult Attachment Interview ; aINS, anterior insula ; BNST, bed nucleus of the stria terminalis ; CPT, cold pressor test ; CS, conditional stimulus ; dACC, dorsal anterior cingulate cortex ; ELA, Early Life Adversity ; ELAI, Early Life Adversity Index ; ELEQ, Early Life Experiences Questionnaire ; Feed, feedback phase ; HR, heart rate ; LC, Life Changes ; LESS, Life Events Scale for Students ; MDD, Major Depressive Disorder ; MFG, middle frontal gyrus ; mPFC, medial prefrontal cortex ; NA, negative affect ; NAcc, nucleus accumbens ; OFC, orbitofrontal cortex ; PA, positive affect ; PANAS, Positive and Negative Affect Schedule ; PSS, Perceived Stress Scale ; rCTS, Revised Conflict Tactics Scale ; RT, reaction times ; STAI, State-Trait Anxiety Inventory ; TAQ, Traumatic Antecedents Questionnaire ; TSS, Traumatic Stress Schedule ; TSST, Trier Social Stress Test ; VS, ventral striatum ; VTA, ventral tegmental area. The reward-related response bias is an empirically-based measure of reward responsiveness which evaluates participants' propensity to choose the response paired with reward or with more frequent reward. \* The rewarding stimuli were presented without any decision or performance required.

## **2.2.2 Effects of cognitive effort**

Cognitive effort is of strong interest as it is thought to modulate motivation and behaviors (Westbrook & Braver, 2015). In daily life, reward and effort are usually intertwined, with cognitive processes being intrinsically linked to motivational and hedonic processes (Kringelbach & Berridge, 2010; Kroemer et al., 2014). Every response or decision requires certain costs for obtaining a desired outcome or before attaining a goal (Phillips, Walton, & Jhou, 2007). Effort refers to the degree of willingness to engage in demanding tasks, the deployment of cognitive and physical resources to enhance performance, and the length of time during which these cognitive resources are engaged (Kahneman, 1973; J. E. Russo & Doshier, 1983). In other terms, cognitive effort represents the subjective experience of up-regulating the cognitive processes in the pursuit of a goal, and the cost engendered by the attentional deployment (Yee & Braver, 2018). Therefore, cognitive effort is intrinsically linked to performance, as high cognitive engagement is likely to increase the attentional deployment resulting in enhanced performance (Westbrook & Braver, 2015). Cognitive effort is also tightly related to motivation by mediating the effects of motivation on performance (Vassena et al., 2014). In the present thesis, cognitive effort is more specifically conceptualized as the spatial WM resources expended in the task as a function of both the potential benefit of effort investment (i.e. monetary gains), and the cost of cognitive engagement (i.e. attentional resources). In other terms, WM refers in this thesis to the capacity to allocate the limited amount of attentional resources in order to maintain, manipulate and store information in memory for a short-term duration (e.g. Baddeley & Hitch, 1974; Engle, 2002).

### **2.2.2.1 Rationale to focus on working memory effort**

To investigate WM is determinant due to the importance of this cognitive function when learning, reasoning, valuating between cost and benefit, planning goal-oriented actions and regulating emotional states (Collette & Van der Linden, 2002; Etkin, Büchel, & Gross, 2015; Gilbert & Fiez, 2004; Pochon et al., 2002). WM is also particularly relevant to study in relationship with reward processing since both have been strongly linked to DAergic transmission in animals and humans (for a review see: Cools & D'Esposito, 2011; see also: D'Ardenne et al., 2012), such as in the striatal regions (for a review see: Chatham & Badre, 2015; see also: Landau, Lal, O'Neil, Baker, & Jagust, 2009). DA signals the availability and probability of predicted rewards and the degree of effort (e.g. cognitive demand) required to obtain it, resulting in the willingness or not to expend cognitive effort (Garbarino & Edell, 1997; Sennwald, Pool, & Sander, 2017; Westbrook &

Braver, 2015). Beside the role of midbrain DAergic neurons in estimating cost-benefit, the phasic activation of these neurons was implicated in WM processes (Salamone, 2009; Salamone & Correa, 2012), such as updating task-relevant information (Cools & Robbins, 2004). On the one hand, increasing WM load reduced accuracy while increasing the involvement of a set of prefrontal and limbic regions during a spatial delayed response task as demonstrated by Glahn and colleagues (2002) (see Figure 2.10). On the other hand, spatial WM performance was shown to scale upon reward magnitude, with rewards of higher value leading to higher performance (Kennerley & Wallis, 2009). Taken together, a crucial question tackled in this thesis is how variable levels of WM load modulate the propensity to exert WM effort for obtaining a predicted reward in an adapted version of Glahn’s task and how WM load interacts with an unpredictable stressor to modulate the willingness to exert effort for a reward. In this framework, the forthcoming sections discuss the relationship linking cognitive effort to reward.

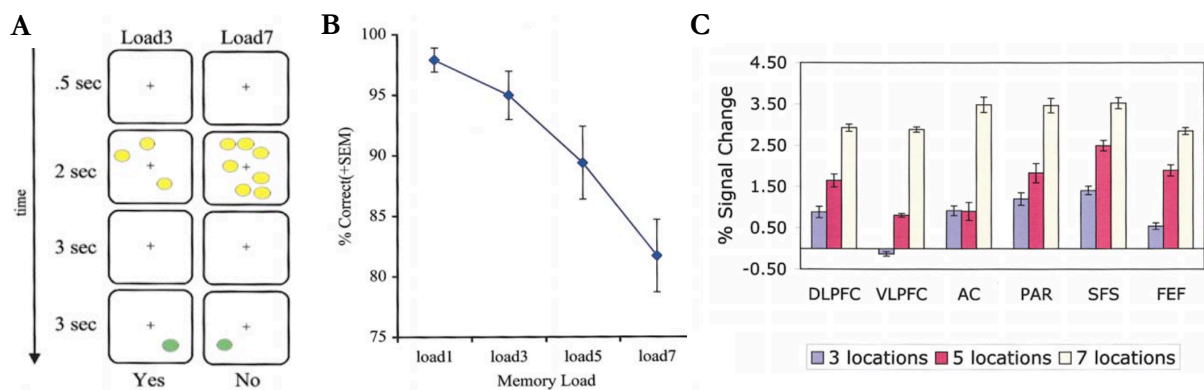

Figure 2.10. Spatial delayed response task with multiple working memory (WM) loads (Glahn et al., 2002). (A) Illustration of two trials with their timing, one under low WM load (Load3, three yellow circles) and the other under high WM load (Load7, seven yellow circles). (B) Behavioral performance (i.e. percentage of correct responses) relative to WM loads including one (load1), three (load3), five (load5) and seven (load7) circles to remember. Response accuracy decreased near-linearly according to the level of WM load. (C) Percentage of signal change in prefrontal regions usually involved in WM processes, with increased activation in each region as a function of increased WM load. AC, anterior cingulate cortex (BA 32); DLPFC, dorsolateral prefrontal cortex; FEF, frontal eye fields ; PAR, posterior parietal cortex (BA 7, BA 39, and BA 40); SFS, superior frontal sulcus; VLPFC, ventrolateral prefrontal cortex. Adapted from Glahn et al. (2002, p. 204, 205).

### **2.2.2.2 Behavioral and neural effects of cognitive effort on reward processing**

Mounting evidence has demonstrated the interest of exploring the influence of cognitive effort in modulating motivated behaviors (Yee & Braver, 2018). Usually, individuals are less prone to engage in a demanding cognitive task when the cognitive effort to allocate is evaluated as higher than the potential reward (Kool, McGuire, Rosen, & Botvinick, 2010; Shenhav et al., 2017). Following a principle called the “law of less work” (Hull, 1943), motivated behaviors are usually guided by the aim of minimizing the work to exert while promoting options with the better cost-benefit ratio (Kahneman & Tversky, 1982; Tversky & Kahneman, 1992). As discussed here after, the influence of cognitive effort on motivated behaviors is complex, reducing or strengthening the willingness to work for rewards depending on the circumstances.

#### **2.2.2.2.1 Effort-discounting effect on motivation**

Motivation that guides behaviors is driven by cost-benefit estimation in which costs such as effort and risk are weighted against benefits such as reward (Apps, Grima, Manohar, & Husain, 2015). Compatible with the idea that motivation for reward is directly influenced by the extent of effort required to obtain it, there is ample evidence suggesting that a higher amount of both physical (e.g. Apps et al., 2015; Bonnelle et al., 2015; Kurniawan et al., 2010) and cognitive (e.g. Botvinick, Huffstetler, & McGuire, 2009; Krigolson, Hassall, Satel, & Klein, 2015) efforts diminishes the value attached to a reward. In other terms, effort-discounting refers to the principle that the value attributed to a potential reward is inversely related to the degree of effort required for obtaining the predicted reward (Botvinick, Huffstetler, et al., 2009). During reward anticipation, cognitive effort was shown to reduce the striatal reactivity to predicted rewards in rats, with reduced NAcc activation when the effort to exert was higher (e.g. Croxson, Walton, O'Reilly, Behrens, & Rushworth, 2009; Gan, Walton, & Phillips, 2010; Walton, Kennerley, Bannerman, Phillips, & Rushworth, 2006). Pharmacological studies supported the idea that DA depletion in the NAcc of rats reallocates instrumental reward-driven behaviors by promoting less demanding actions associated with lower rewards (for a review see: Salamone, Correa, Farrar, & Mingote, 2007). In line with animal data, neuroimaging studies in healthy humans evidenced essentially the recruitment of the striatum and the ACC during the cost-benefit process (Kurniawan et al., 2010; Stoppel et al., 2011; Vassena et al., 2014), by showing for instance higher activation in the putamen when participants decided to perform less demanding physical effort (i.e. gripping with less force) (Kurniawan et al., 2010). During reward delivery, the exertion of higher cognitive effort resulted in decreased NAcc responsiveness (Botvinick, Huffstetler, et al., 2009). Interestingly, NAcc

responsiveness to reward delivery was associated with dACC activation during reward anticipation, a region implicated in encoding the subjective experience of effort (Botvinick, Huffstetler, et al., 2009).

Taken together, findings suggest that physical and cognitive effort might reduce motivated behaviors toward predicted rewards, and reward responsiveness during delivery. A neural hypothesis proposed to explain this effort-discounting effect relies on the idea that the anticipation processes of both cognitive effort and expected rewards engage the same DAergic cortico-limbic brain network (Vassena et al., 2014), so that anticipation of rewards and effort might compete for the same attentional resources (Stoppel et al., 2011).

#### 2.2.2.2.2 The paradox of effort motivation to work harder : enhancing effect of cognitive effort

While people are prone to work harder for something they value such as rewards, an idea less frequently considered is that the increased effort exerted is also able to increase the value of the predicted outcome (for a review see: Inzlicht, Bartholow, & Hirsh, 2015). In line with this idea, NAcc responsiveness to positive performance feedback was shown to scale upon task difficulty, with strengthened NAcc activation to positive feedback following higher cognitive effort (Satterthwaite et al., 2012). Interestingly, neuroimaging studies in humans evidenced recently that in the same way as reward anticipation, effort anticipation can have a similar motivational effect on the engagement of the ventral striatum (Kroemer et al., 2014; Vassena et al., 2014), the ACC (Vassena et al., 2014), and the amygdala (Kroemer et al., 2014). However, data suggest that this similar motivational effect of engaging oneself in a challenging cognitive task might only occur when it is the voluntary choice of people to choose to work harder (Schouppe, Demanet, Boehler, Ridderinkhof, & Notebaert, 2014). In sum, these emerging findings indicate that the processing of reward and cognitive effort might recruit a shared neural circuitry including mainly the NAcc, the ACC, the vmPFC, and the amygdala. Both cognitive effort and reward magnitude modulate together the invigoration of motivated behaviors, with complex relationships resulting in some circumstances in enhancing effect of effort on motivation and in other in effort-discounting effect. With the aim of exploring the complex associations linking cognitive effort to the reward processing and stress reactivity, the next section covers recent studies that document the effects of reinforcement (i.e. reward) and of exposure to an acute experimental stressor on cognitive performance.



### **2.2.2.3 How is cognitive effort affected by reward and stress ?**

Reward is known to enhance motivation to engage in cognitive effort, resulting in higher performance (K. C. Berridge, 2004; Niv, Daw, Joel, & Dayan, 2007; Pessoa, 2013). When the reward delivery is contingent upon instrumental performance, people are more willing to work harder (Manohar, Finzi, Drew, & Husain, 2017; Yee & Braver, 2018). For instance, the anticipation of positive reinforcement including the receipt of sweet taste (Savine, Beck, Edwards, Chiew, & Braver, 2010) or the avoidance of aversive taste (Savine et al., 2010) and monetary loss (Krawczyk & D'Esposito, 2013) resulted in increased WM performance in healthy humans. During delivery, the receipt of reward can lead to a re-evaluation of effort expended to obtain it, with reward higher than expected associated with an overestimation of the effort expended whereas in contrast rewards lower than expected result in the underestimation of the effort exerted (Pooresmaeili, Wannig, & Dolan, 2015). This is in line with the motivational intensity theory (Brehm & Self, 1989) which stipulates that people expend effort proportionally until the demand exceeds their ability or when the outcome value doesn't justify to exert this amount of effort.

When considering the effect of acute stress on WM processes, both enhancing and impairing effects of stress exposure were demonstrated. In accordance with animal studies (for a review see: Czakoff, Johnson, & Howland, 2010), WM performance is reduced by the exposure to an acute experimental stressor (Luethi, 2008; Schoofs, Preuß, & Wolf, 2008), in particular in people showing a strong cortisol reactivity to the stressor (Elzinga & Roelofs, 2005; Oei, Everaerd, Elzinga, van Well, & Bermond, 2006; Qin, Hermans, van Marle, Luo, & Fernández, 2009). Additionally, stress-related reduction in WM performance was associated with decreased activation in prefrontal regions such as the dlPFC (Qin et al., 2009). Contrasting with findings showing a stress-induced WM break-down, recent works in rodents (e.g. Yuen et al., 2009, 2011) and humans (e.g. Weerda, Muehlhan, Wolf, & Thiel, 2010) evidenced that stress could also enhance WM performance. Neural correlates of WM processes during stress exposure suggest that increased recruitment of prefrontal regions might contribute to maintain or even enhance cognitive performance (Porcelli et al., 2008; Weerda et al., 2010; Yuen et al., 2009, 2011). These conflicting results presented in the literature indicate that stress might exert differential effects on higher-level cognitive processes over time (Hermans et al., 2014). Characterized by an inverted U-shape, the effect of stress exposure might impair higher-order executive processes rapidly after the onset of stress, improve them then over time and again impair them during sustained exposure (Mendl, 1999; van Oort et al., 2017).

In sum, reward was reported consistently as a strong facilitator of cognitive performance, in particular WM performance. In contrast, the effects of stress on WM are less clear, with results showing impairing and enhancing influences on WM performance. To the best of our knowledge, only one preliminary study explored recently how reward and stress interacted to influence cognition. This study showed that predictable threat-of-shock counteracted the beneficial effect of monetary reward on WM performance, or in other terms decreased willingness to exert WM effort to obtain a monetary reward (J. M. Choi, Padmala, & Pessoa, 2015). A lack of willingness to engage in cognitive effort was implicated in several mental disorders (Cambridge, Knight, Mills, & Baune, 2018; Cohen, 2001; Treadway, Bossaller, Shelton, & Zald, 2012), as for instance major depression which is characterized by symptoms including anhedonia, reduced motivation, depressed mood, and cognitive impairments (Klein-Flügge, Kennerley, Saraiva, Penny, & Bestmann, 2015). A question raised by the co-occurrence of these symptoms is whether cognitive resources at disposal might constitute a major factor of influence in the normal reward processing.

Taken together, this thesis aims at unraveling (i) how the exposure to unpredictable acute stress affects reward processing, and (ii) how variable levels of cognitive demands modulate the effects of stress exposure on reward processing in healthy adults. Studying how healthy individuals anticipate predicted rewards, and how they react to reward delivery when they are confronted to unpredictable acute stressors in conjunction with variable levels of cognitive demand might open important avenues to understand the development of anhedonic symptoms.

### **2.3 REWARD PROCESSING UNDER STRESS AND COGNITIVE LOAD : CLINICAL IMPLICATIONS FOR THE VULNERABILITY TO MAJOR DEPRESSION**

The first aim of this thesis is to understand how stress exposure affects reward processing in healthy adults with the intention of yielding new promising insights on vulnerability factors involved in the development of stress-related psychopathologies, in particular mental disorders marked by a loss of motivation and of hedonia. The second aim of this thesis is to investigate how cognitive resources at disposal might contribute to modulate the effect of stress exposure on reward processing in healthy adults. Among mental disorders strongly affected by impaired reward processing (Admon & Pizzagalli, 2015b; Hägele et al., 2015; Hasler et al., 2004; Luking, Pagliaccio, Luby, & Barch, 2016; Martin-Soelch, 2009; Nelson, Kessel, Klein, & Shankman, 2018), increased stress sensitivity (Anisman & Matheson, 2005; Dienes, Hazel, & Hammen, 2013; Goodyer, Bacon, Ban, Croudace, & Herbert, 2009; Gotlib et al., 2010; Hasler et al., 2004; Hasler & Northoff, 2011; Keller, Neale, & Kendler, 2007), and impaired cognitive processes (for a review see: Kujawa & Burkhouse, 2017), major depression is one of the most important burden in terms of disability in Switzerland (Baer, 2003; Tomonaga et al., 2013) and worldwide (Bromet et al., 2011; Wittchen et al., 2011). The diagnostic of MDD is described by discrete episodes lasting at least two weeks during which significant changes occur in mood, hedonia, cognition, and neurovegetative functions (American Psychiatric Association, 2013). Specifically, the two core symptoms include (i) a depressed mood reported as a feeling of being sad, empty or hopeless, and/or (ii) a markedly loss of interest or pleasure in the majority of activities. Although relevant treatments exist, MDD is characterized by a complex etiology and a pathophysiology that are still poorly understood (Hasler & Northoff, 2011; Pizzagalli, 2014).

In this framework, the fourth aim of this thesis is to use the vulnerability to depression as a clinical model to test the implications of stress exposure on the reward processing as risk factor for the development of anhedonic symptoms. Specifically, we want to explore whether the effect of stress exposure on reward processing might differentiate between healthy adults without and with increased familial vulnerability to depression. As exploratory question, we examine whether variable levels of cognitive demands modulate differentially the effects of stress exposure on reward processing in healthy adults without and with increased familial vulnerability to depression. Genetic heritability and environmental factors were extensively evidenced as determinant contributors to the etiological pathway of MDD (Gotlib, Joormann, & Foland-Ross, 2014; McAdams et al., 2014, 2015; Singh et al., 2011; Williamson, Birmaher, Axelson, Ryan, & Dahl, 2004). The role of genetic heritability in the onset of MDD was estimated in a range of 31% to 42% (Sullivan, Neale, & Kendler, 2000). Moreover, research converge to indicate that first-degree relatives of depressed

parents are at twofold to threefold higher risk for the onset of MDD, with the peak of higher vulnerability occurring between 15 and 25 years old (Gotlib et al., 2014; Weissman et al., 2016). Given the higher risk for MDD in this population, it is particularly relevant to study how stress exposure and cognitive demands interact to modulate reward processing in offspring of depressed parents prior to the onset of MDD. Identifying potential biological and psychological vulnerability factors implicated in the development of depressive symptoms might yield new promising avenues for developing efficient interventions and preventions (Hasler, 2010). With this in mind, this section intends first to review the current literature on the reward processing in MDD patients and their first-degree relatives. Second, this section covers the recent findings on the role of stress exposure and stress sensitivity in the onset and maintenance of MDD. Since we are interested in the cumulative effect of cognitive load on the reward processing, the last part of this section examines the deficits in higher-order cognitive functions that characterize specifically MDD.

### **2.3.1 Impaired reward processing : when rewards do not reward anymore**

Anhedonia is a major hallmark feature of MDD (e.g. Römer Thomsen, Whybrow, & Kringelbach, 2015) defined as “markedly diminished interest or pleasure in all, or almost all, activities most of the day, nearly every day” (American Psychiatric Association, 2013, p. 160). Anhedonic symptoms were associated consistently with a dysfunction of the cerebral reward system (for a review see: Dean & Keshavan, 2017), including multifaceted deficits in reward processing such as a lack of motivation for anticipated rewards and/or the inability to experience hedonic feelings from positive stimuli (Der-Avakian & Markou, 2012; Rizvi et al., 2016).

Behavioral, neurophysiological and neuroimaging findings converge to indicate that individuals with MDD are characterized by a difficulty to evaluate potential gains, to engage in motivated behaviors, and to experience pleasure from positive stimuli (for reviews see: Eshel & Roiser, 2010; Pizzagalli, 2014). Behavioral studies evidenced that MDD patients (i) underestimated the value of potential rewards and the probability of obtaining a reward (Treadway, Bossaller, et al., 2012) and (ii) showed decreased willingness to exert higher effort to obtain a predicted reward (Vrieze et al., 2013), notably reflected by increased difficulty to modulate behavior as a function of reward magnitude and reinforcement history (Pechtel, Dutra, Goetz, & Pizzagalli, 2013; Pizzagalli, Iosifescu, Hallett, Ratner, & Fava, 2008; Treadway, Bossaller, et al., 2012). At the neural level, neuroimaging findings reported blunted reactivity during the anticipation of monetary rewards in the ventral striatum (Hägele et al., 2015; Stringaris et al., 2015; Ubl, Kuehner, Kirsch, Ruttorf, Diener, et al., 2015), putamen (Pizzagalli et al., 2008), caudate nucleus (Smoski, Rittenberg, &

Dichter, 2011; Yang et al., 2016), OFC (Smoski et al., 2011; Ubl, Kuehner, Kirsch, Ruttorf, Diener, et al., 2015), and rostral ACC (Ubl, Kuehner, Kirsch, Ruttorf, Diener, et al., 2015) in MDD patients compared to healthy controls. In turn, the processing of reward-related cues resulted in increased activations in the hippocampus, amygdala, ACC, cerebellum and SFG in both MDD and remitted patients compared to healthy controls (Dichter, Kozink, McClernon, & Smoski, 2012; Ubl, Kuehner, Kirsch, Ruttorf, Diener, et al., 2015). During the delivery of monetary rewards, MDD patients demonstrated blunted activation in the NAcc (Carl et al., 2016; Pizzagalli et al., 2009; Redlich et al., 2015) and the caudate nucleus (Pizzagalli et al., 2009), the OFC (Dichter et al., 2012), the insula (Dichter et al., 2012), and the thalamus (Dichter et al., 2012; Smoski et al., 2009) compared to healthy controls. Crucially, the severity of self-reported anhedonic symptoms correlated with the magnitude of reduced behavioral willingness to work for a reward (Pizzagalli et al., 2009; Yang et al., 2014), with higher likelihood of maintenance and chronicity of the depressive symptomatology after eight-week treatment with antidepressants among MDD patients (Vrieze et al., 2013), and with decreased neural activation in the ventral striatum (Hägele et al., 2015; Hanson et al., 2015; Stringaris et al., 2015) and in the globus pallidus (Chung & Barch, 2015) during reward anticipation.

In line with findings in MDD patients, behavioral data evidenced decreased behavioral willingness to exert effort for a predicted reward in first-degree relatives of depressed parents, with the magnitude of the reduction in reward responsiveness associated with depressive symptoms (W. Liu et al., 2016). At the neural level, burgeoning studies in first-degree relatives of depressed parents evidenced reduced reactivity to reward-related cues in the ventral striatum, the caudate nucleus, the putamen and the left insula during the anticipation of monetary rewards (Gotlib et al., 2010; Olinio et al., 2014). The delivery of monetary rewards resulted in decreased activations in the ventral striatum and caudate nucleus (Olinio et al., 2014), OFC (McCabe, Woffindale, Harmer, & Cowen, 2012) and in the left hippocampus (Macoveanu et al., 2014) in first-degree relatives of depressed parents compared to healthy controls. Additionally, the delivery of primary rewards (i.e. pleasant sights or tastes) was associated with reduced NAcc activation in first-degree relatives of depressed parents, with the magnitude of NAcc activation linked to the intensity of the depressive symptoms of their depressed parent (Sharp et al., 2014).

Taken together, findings suggest that abnormal reward processing in MDD is characterized by decreased motivation to engage in goal-oriented behaviors and by the loss of ability to experience hedonic feelings from positive stimuli. In the next section, we discuss the implications of stress exposure and dysregulated reactivity to stress as major contributors to MDD onset, maintenance and relapse.

## **2.3.2 Stress exposure and impaired stress sensitivity as precipitants**

Stress has been evidenced as one of the most important environmental risk factors for depression onset, in particular when it interacts synergistically with existing vulnerability traits (Dienes et al., 2013; Hasler & Northoff, 2011). Here, we discuss the role played by both the exposure to stressful life events, and the increased sensitivity to stress exposure as major contributors to MDD.

### **2.3.2.1 Exposure to stressful life events**

Stressful life events constitute important vulnerability factors for the development of a first depressive episode (Gold, 2015; Hammen, 2005; Kendler & Gardner, 2016), as well as for relapse and recurrence (Beshai, Dobson, Bockting, & Quigley, 2011; for a review see: Buckman et al., 2018). Diathesis-stress models posit that genetic or neurobiological factors constitute diatheses that increase the individual's vulnerability to the onset of psychopathological conditions when confronted to adverse environmental stressors (Belsky et al., 2009; Caspi, 2003; Davidson, Pizzagalli, Nitschke, & Putnam, 2002; Sullivan et al., 2000). Therefore, depressive symptoms are the product of an interaction between premorbid risk factors and exposure to major stressors, with approximately 20% to 50% of individuals developing a first depressive episode after having experienced a recent significant life stressor (Ingram & Luxton, 2005; Monroe & Simons, 1991). Nevertheless, recent data suggested that after the first onset of a major depressive episode, the link between subsequent depressive episodes and the occurrence of stressful life events becomes weaker, indicating that the depressive relapse becomes increasingly independent from environmental factors (Kendler & Gardner, 2016; Lewinsohn, Allen, Seeley, & Gotlib, 1999).

An important factor modulating the potential harmful effect of the exposure to adverse events is their time of occurrence, with the strongest effect when they happen during periods of increased plasticity of brain regions (Karg, Burmeister, Shedden, & Sen, 2011; for a review see: Lupien, McEwen, Gunnar, & Heim, 2009). Another critical aspect is the nature of the stressor, while not all stressors have the same effect and depressive-like implications (Anisman & Matheson, 2005). Specifically, research documented the link between increased risk for depression and the exposure to different types of stressors, including early life stressors (for reviews see: Chen & Baram, 2016; Heim & Binder, 2012), recent stressful life events (Hammen, Kim, Eberhart, & Brennan, 2009; Kendler, Karkowski, & Prescott, 1999; M. Strauss et al., 2018), and chronic stressors (i.e. daily hassles) (Hammen, Dalton, & Thompson, 2015; Hammen et al., 2009; Stefanek, Strohmeier, Fandrem, & Spiel, 2012). Interestingly, data demonstrated that men and women were

sensitive to different types of stressor (Hasler, 2010). While psychosocial stressors might have a stronger deleterious effect in females compared to males, job-related stressors as well as divorce or separation might be more harmful in males compared to females (Kendler, Thornton, & Prescott, 2001; Mazure, 2000). The feeling of controllability over the stressor is a determinant factor modulating the vulnerability to the occurrence of depressive symptoms (Anisman & Matheson, 2005). Thus, stressful life events evaluated as uncontrollable by the individual are likely to result in stronger depressive symptoms, feelings of anxiety, and helplessness when dealing with it (Breier, 1987; Henn & Vollmayr, 2005; Koolhaas et al., 2011).

#### 2.3.2.1.1 Linking stressful life events to depression, an unidirectional relationship ?

Based on the stress exposure model of depression, early research postulated that the relationship between stress exposure and depression was unidirectional, with stressful life events increasing significantly the risk for depression (for a review see: R. T. Liu & Alloy, 2010). Within the past decades, new models emerged to better account for the complex role of stress as risk factor for depression. In this framework, the stress generation model of depression postulates that individuals at increased risk for depression don't respond only passively to environmental adversity, but might play rather an active role by generating stressful conditions, and hence contributing to be confronted to negative life events (Hammen, 1991). In other words, individuals would be confronted to stressors whose nature is dependent upon their own genetic and psychological risk factors (Kendler et al., 1999; Kendler & Karkowski-Shuman, 1997; R. T. Liu et al., 2014). According to this model, depressive symptoms contribute to the subsequent experience of negative life events which, in turn, increase the probability of depressive recurrence and relapse (Kendler & Karkowski-Shuman, 1997).

### **2.3.2.2 Heightened sensitivity to stress in major depression**

The sensitization of the biological stress system is a promising vulnerability factor linking stress to depression (E. K. Adam et al., 2010). For instance, data evidenced the role of childhood adversity and trauma in increasing the sensitivity to subsequent stressful life events (for a review see: Heim & Nemeroff, 2001). Although the mechanism by which sensitization of the biological stress system is activated in response to early adversity is not fully understood, stress sensitization might result from the strong effects of environmental stressors on genetic and neurobiological processes linked to the biological stress system (Lupien et al., 2009). According to the hypothalamic-pituitary-cortisol hypothesis of major depression, abnormalities in the stress response mediated by the HPA system constitute a major biological marker of MDD (Belmaker & Agam, 2008). In line with this hypothesis, literature documented a strong relationship linking MDD to abnormalities of the HPA axis including (i) higher levels of stress-related hormones such as the CRH released by the hypothalamus in the cerebrospinal fluid, and the cortisol released by the adrenal gland into the plasma, (ii) increased size of the adrenal cortex, and (iii) reduced size of the hippocampus (for reviews see: Arborelius, 1999; Chrousos, 2009; Swaab, Bao, & Lucassen, 2005).

Specifically, increased cortisol reactivity during the waking period was associated with decreased hippocampal size (for a review see: Frodl & O'Keane, 2013), and extensively documented in MDD patients (for a review see: Boggero, Hostinar, Haak, Murphy, & Segerstrom, 2017), in medicated remitted MDD patients (Vreeburg et al., 2009), and in unmedicated remitted MDD patients (Aubry et al., 2010; Bhagwagar, Hafizi, & Cowen, 2003). In an experimental setting, MDD patients demonstrated higher cortisol levels before stress exposure (for a review see: Handwerker, 2009) and during the recovery period compared to healthy controls (Burke, Davis, Otte, & Mohr, 2005). Also, recent data indicated that experimental stress exposure had a differential effect in depressed women compared to depressed men. Depressed women tended to show blunted cortisol stress response, while depressed men displayed increased cortisol responses to experimental stressors (for a review see: Zorn et al., 2017). To the best of our knowledge, only one study explored so far the reactivity of the HPA system in response to acute stress exposure in laboratory settings among individuals at increased familial risk for depression (Dienes et al., 2013), claiming for additional investigations. This study suggested that the cortisol concentration in response to acute stress didn't differ significantly between healthy controls and at-risk individuals.

Nevertheless, the role played by the HPA system in major depression is not yet clear, as indicated by inconsistent findings suggesting blunted stress responses during waking period in daily life (for reviews see: Boggero et al., 2017; Dedovic et al., 2005). A promising hypothesis that might contribute to clarify these inconsistencies suggests the existence of a non-linear relationship



characterized by an inverted U-shape function between depressive symptoms and the level of cortisol response during awakening period (Dedovic & Ngiam, 2015). Low or mild depressive symptoms showed a similar pattern of basal cortisol levels as healthy controls, while moderate depressive symptoms were associated with increased basal cortisol levels, and severe depressive symptomatology related to decreased or blunted basal cortisol levels (Veen et al., 2011; Wardenaar et al., 2011). Together with this hypothesis, a recent longitudinal study evidenced that higher salivary cortisol concentration didn't predict increased vulnerability to depression *per se*, but suggested rather that low mean salivary cortisol concentration and a small difference between the morning and evening cortisol concentration constituted the strongest risk factor for depression (Grynderup et al., 2013).

Taken together, a wealth of data indicates that stress is a determinant precipitant for the onset of a first depressive episode, as well as for the maintenance and the recurrence of major depression. Based on diathesis-stress models, premorbid vulnerability factors might predispose the individual to increased risk for depression, in particular when confronted to stressful life events. Dysregulated stress response characterized by abnormal HPA activity might constitute one determinant premorbid vulnerability factor that might enhance the sensitivity to negative life events. The next section discusses the burgeoning literature at the interplay of stress and reward reactivity, two promising vulnerability factors for MDD.

### **2.3.3 Interaction between the reward and stress systems**

Stress-induced impairment of the brain reward circuitry has been proposed to constitute a promising candidate biomarker linking stress to depression (for reviews see: Bogdan et al., 2013; Pizzagalli, 2014). Also called the reward dysfunction model or the reward mediation model (Auerbach, Admon, & Pizzagalli, 2014), this hypothesis is supported by studies in animals (Mangiavacchi et al., 2002; for a review see: Willner, 2005) and humans (Admon et al., 2013; Bogdan & Pizzagalli, 2006). A pioneer study investigated the effect of stressful life events on the ability to experience pleasure, by showing that field training exercises in cadets of the US army and final examinations in college students induced a reduction in the pleasure experienced during amusing movie clips (Berenbaum & Connelly, 1993). More recently, behavioral data evidenced that the exposure to an acute experimental stressor (i.e. threat-of-shock or negative performance feedback) (Bogdan & Pizzagalli, 2006) and to higher stressful life events over the past month (Pizzagalli et al., 2007) were associated with negative affects and reduced reactivity to predicted rewards as reflected by the decreased ability to modulate behavior as a function of reinforcement.

This is in line with recent data showing the relationship between the blunted ventral striatal activation in response to reward, and anhedonic symptoms, in particular in individuals confronted to adversity during childhood (Corral-Frías et al., 2015). Nevertheless, the data linking stress-related anhedonia to depression remain scarce, calling for additional evidence to deepen our understanding of how stress and reward systems interact to modulate the vulnerability to major depression. Since MDD was associated with impairments in multiple higher-order cognitive processes (for a review see: Snyder, 2013), a promising lead is to explore whether first-degree relatives of depressed parents are more strongly affected by the cumulative effects of stress exposure and cognitive demands on their behavioral and neural responsiveness to rewards. In this framework, the next section discusses briefly the current literature on the abnormalities in higher-order cognitive processes observed in MDD patients and their first-degree relatives.

#### **2.3.4 Cognitive impairments**

MDD is also characterized by broad cognitive impairments reflected by symptoms as the “diminished ability to think or concentrate, or indecisiveness, nearly every day” (American Psychiatric Association, 2013, p. 161). In daily life, higher-order cognitive processes are essential for successfully and flexibly respond to environmental demands, in particular in non-habitual situations (Diamond, 2013). Often called also executive functions, higher-order cognitive processes refer to a set of cognitive functions that are effortful, but essential for guiding adaptively and flexibly goal-oriented behaviors, in particular in non-habitual situations (Banich, 2009). More specifically, executive functions include the abilities of “prioritizing and sequencing behavior, inhibiting familiar or stereotyped behaviors, creating and maintaining an idea of what task or information is most relevant for current purposes (often referred to as an attentional or mental set), providing resistance to information that is distracting or to an irrelevant task, switching between task goals, utilizing relevant information in support of decision making, categorizing or otherwise abstracting common elements across items, and handling novel information or situations” (Banich, 2009, p. 89).

Cognitive impairments associated with MDD remain still unclear, with conflicting findings regarding the nature and intensity of these dysfunctions, which might partly result from the negative effects of medications (for a review see: Rogers et al., 2004). While alterations in multiple higher-order cognitive processes were evidenced in depressed patients (for a review see: Snyder, 2013), some data suggest that MDD might not be specifically marked by cognitive impairments in a broad range of cognitive functions, but rather by deficits in more specific functions including

cognitive flexibility such as shifting (Grant, Thase, & Sweeney, 2001). In particular, cognitive flexibility and the ability to shift one's attention toward relevant information might be the most impaired cognitive functions in MDD (Marazziti, Consoli, Picchetti, Carlini, & Faravelli, 2010). For instance, MDD patients are particularly prone to attentional biases toward negative informations regardless of their relevance (Bourke, Douglas, & Porter, 2010; Martin-Soelch, 2009; Peckham, McHugh, & Otto, 2010). Interestingly, first-degree relatives of depressed parents show similar attentional biases toward negative contents when they are exposed to a stressor or when negative emotions are induced (for a review see: Gotlib et al., 2014). One hypothesis is that these cognitive dysfunctions might reflect the cognitive biases that characterize MDD patients toward themselves, their environment and the future (triad of negativity) (Chamberlain & Sahakian, 2006).

The present thesis focuses more specifically on how WM demands modulate the effect of stress exposure on reward processing. WM is an essential higher-order cognitive process which is thought to constitute a common mechanism required for the proper functioning of every executive function by maintaining adaptively the current goal and context information (Miyake et al., 2000). Therefore, disrupted WM processing might result in diminished regulatory abilities, in particular during stress exposure. Several studies reported that MDD patients showed impaired WM (for a review see: Marazziti et al., 2010). Compared to healthy controls, MDD patients displayed significant WM dysfunctions in a *n*-back task (Rose & Ebmeier, 2006) and difficulty to inhibit or delete irrelevant information during WM processing (Gohier et al., 2009). Interestingly, a recent study suggested that depressed thoughts might lead to altered WM processing when the depressive thoughts are activated by negative cues (Hubbard, Hutchison, Hambrick, & Rypma, 2016). This may indicate that dysfunctions in higher-order cognitive functions such as WM processing is intrinsically related to negative affects and ruminations. Of clinical importance, cognitive impairments are often persistent and remain even after remission (Reppermund, Ising, Lucae, & Zihl, 2009), thus increasing the risk for relapse (Porter, Bowie, Jordan, & Malhi, 2013). The development of prevention and treatment programs targeting impairments in higher-order cognitive functions is therefore crucial. In this context, cognitive remediation was proposed as a promising treatment approach developed for improving cognitive symptoms that are characteristic of MDD (Porter et al., 2013; Semkovska & Ahern, 2017). Preliminary findings suggest that a computerized neurocognitive remediation therapy might contribute significantly to improve targeted cognitive symptoms during remission (Semkovska & Ahern, 2017).

Taken together, research indicates that MDD patients show often deficits in higher-order cognitive functions including mainly WM, attention, inhibition, and shifting processes. However, little is known so far about how WM demands modulate the effect of stress exposure on reward

processing in individuals at increased familial risk for depression. Therefore, the fourth aim of this thesis is to investigate how WM demands might modulate the effect of stress exposure on motivational and hedonic processes, and whether this modulation can differentiate healthy adults without and with increased familial vulnerability to MDD.

### **2.3.5 Summary of the theoretical background**

In sum, the ability to detect rewards and threats is crucial for survival, well-being, and adjustment to the environment (Haber & Knutson, 2010). The pursuit of beneficial rewards and the avoidance of detrimental consequences are at the heart of what engenders and promotes motivated behaviors (K. C. Berridge & Kringelbach, 2013; Der-Avakian & Markou, 2012). At the interplay between the reward and stress systems, both the midbrain DAergic neurons and the regions receiving their DAergic projections play a determinant role in promoting approach or avoidance behaviors (Boekhoudt et al., 2018; Hassan & Benarroch, 2015; Schultz, 2017). A valuation system centered on the striatum is recruited for encoding the motivational salience and motivational valence of predicted positive consequences such as rewards. This ability to evaluate the salience and valence of a stimulus is crucial for implementing relevant reward-seeking behaviors. During the receipt of positive outcomes, the striatum and vmPFC are particularly implicated in the encoding of the subjective reward value and in the cognitive representation of this hedonic value (Kringelbach, 2003, 2005). However, the pursuit of valuable goals and the ability to experience hedonic feelings from positive reinforcers can become dysfunctional, resulting in increased vulnerability to mental health conditions such as major depression. For instance, data indicate that the reward function is particularly sensitive to stress exposure (Bromberg-Martin et al., 2010; Pani, Porcella, & Gessa, 2000; Pizzagalli et al., 2007; Pool et al., 2015; Porcelli et al., 2012), as evidenced by the detrimental effect of acute and chronic stress on the reward processing. However, little is known about the mechanisms at stake and under which conditions stress exposure affects reward processing in humans. Among potential influencing factors, higher-order cognitive functions might modulate importantly the effects of stress exposure on reward processing through a top-down cognitive regulation of these systems anchored in subcortical structures (Ernst, 2014; Heatherton & Wagner, 2011; Ray & Zald, 2012).

In view of the above, the first aim of this thesis is to explore (i) how stress exposure acts on the reward processing, and the second (ii) how variable levels of cognitive effort to invest in the task modulate the influence of stress on reward processing. These factors have a strong clinical significance as they are involved in several debilitating mental disorders characterized by complex

etiological pathways. Given that anhedonia has been associated with an impaired ability to experience hedonic feelings along with difficulties in emotion regulation, the third aim of this thesis was to examine how adaptive and maladaptive emotion regulation strategies are associated with the ability to experience hedonic responses in healthy adults. Of clinical importance, MDD is characterized by an imbalance between the reward and stress systems, with reduced reward responsiveness (Admon & Pizzagalli, 2015a; Hägele et al., 2015; Hasler et al., 2004; Luking et al., 2016; Martin-Soelch, 2009; Nelson et al., 2018) and increased stress reactivity (Anisman & Matheson, 2005; Dienes et al., 2013; Goodyer et al., 2009; Hasler et al., 2004; Hasler & Northoff, 2011; Keller et al., 2007). In this framework, the vulnerability to depression was used as a clinical model in this thesis to explore as fourth aim (iv) the implications of stress exposure on the reward processing as risk factor for the development of anhedonic symptoms. In an exploratory way, this thesis investigated also whether variable levels of cognitive effort modulate the effect of stress exposure on reward processing in a different manner in healthy adults without and with increased familial vulnerability to depression.



# CHAPTER 3

## AIMS AND HYPOTHESES

---

# AIMS AND HYPOTHESES

---

The literature exploring how reward and stress interact in humans remains scarce, with inconsistent findings showing both adverse and sometimes enhancing effects induced by stress exposure on the reward function. The mechanisms underlying such effects are unclear, calling for better knowledge of the potential influencing factors implicated in stress-related effects on reward processing, in particular in the development of anhedonic symptoms including the loss of motivation and of ability to experience pleasure (Dillon et al., 2014). The level of cognitive effort might constitute a crucial factor influencing the availability of regulatory processes and that might therefore modulate the effect of stress exposure on the reward processing.

In this framework, the **first aim** of this thesis was to examine how stress exposure affects the basic neural mechanisms of reward processing in healthy adults, with the intention of yielding new insights on the vulnerability factors implicated in the onset of stress-related psychopathologies. The **second aim** of this thesis was to explore how variable levels of cognitive effort might contribute to modulate the effects of stress exposure on the basic neural mechanisms of reward processing in healthy adults. For this purpose, reward processing during anticipation and delivery of monetary reward was assessed during a spatial delayed response task with two reinforcement schedules (rewarded, not-rewarded) and two levels of cognitive load (low, high). Stress reactivity was manipulated during the stress condition with threat-of-shock and compared to the control condition devoid of experimental stressor.

Given that anhedonia has been linked to a disturbed ability to experience hedonic feelings along with difficulties in emotion regulation, the **third aim** of this thesis was to test whether the propensity of healthy adults to use adaptive or maladaptive emotion regulation strategies assessed with a self-reported questionnaire is associated with the striatal responsiveness to reward delivery, with a particular focus on the NAcc activation. Exploring how reward responsiveness and emotion regulation interact might provide a better understanding of the vulnerability factors at play in mental health disorders characterized by dysfunctions of the reward system, as for instance MDD. Therefore, we also examined whether both (i) the NAcc responsiveness to reward delivery, as well as (ii) the use of adaptive and maladaptive emotion regulation strategies are associated with the severity and intensity of subclinical depressive symptoms in healthy individuals. Specifically, the inability to experience hedonic feelings from positive stimuli and the difficulty to engage in



motivated behaviors are core symptoms of MDD (American Psychiatric Association, 2013). Nevertheless, the etiological pathway leading to the onset of MDD is still poorly understood.

In this framework, the **fourth aim** of this thesis was to use the vulnerability to depression as a clinical model to test the implications of stress exposure and variable levels of cognitive effort on the neural mechanisms of reward processing as risk factors for the development of anhedonic symptoms. In particular, our purpose was to explore (i) whether the effect of stress exposure on the reward processing might differentiate between healthy adults without and with increased familial vulnerability to MDD, and (ii) whether cognitive effort modulates the effect of stress exposure on the reward processing by distinguishing healthy adults without from those with increased familial vulnerability to MDD. With this aim, the same spatial delayed response task with two reinforcement schedules (rewarded, not-rewarded) and two levels of cognitive load (low, high) was used in a control condition devoid of experimental stress and compared to a stress condition (i.e. threat-of-shock).

This chapter introduces the three empirical works embedded in this thesis and associated with our research questions and hypotheses. These experimental works are presented in the Chapters 5, 6 and 7 in the form of three papers, followed by a general discussion summarizing the major findings, their clinical implications, their limits, and finally new perspectives.

### 3.1 EMPIRICAL WORK I - STRIATAL RESPONSIVENESS TO REWARD UNDER THREAT-OF-SHOCK AND WORKING MEMORY LOAD

A wealth of research explored (i) the effect of stress exposure on the reactivity to reward (Berghorst et al., 2013; Boecker et al., 2014; Bogdan & Pizzagalli, 2006; Ginty, 2013; Hanson et al., 2015; Porcelli et al., 2012), as well as (ii) the relationship linking higher-order cognitive functions to motivational and hedonic processes (Botvinick, Huffstetler, et al., 2009; Satterthwaite et al., 2012; Vassena et al., 2014). To the best of our knowledge, no data examined so far how stress exposure and varying levels of cognitive effort modulate together the reward-related processes involved in motivation and pleasure.

By using an event-related functional fMRI task, our first empirical work aimed at investigating how the exposure to an unpredictable stressor (threat-of-shock) influences the neural reactivity to reward under variable levels of cognitive effort (WM load) to expend for getting a monetary reward. In line with previous findings, we hypothesized **first** that the unpredictable acute stressor would strengthen striatal activation in response to cued reward during the anticipatory phase. **Second**, we expected that the unpredictable acute stressor would reduce striatal activation in response to reward during the delivery phase. **Third**, we assumed that high WM load would hinder the enhancing effect of stress exposure on striatal responsiveness to reward anticipation, but would enhance the blunting effect of stress exposure on the striatal responsiveness to the delivery of monetary reward. **Fourth**, we hypothesized that at the behavioral level both the exposure to an unpredictable acute stressor and the higher cognitive load would act synergistically to decrease the performance, specifically inducing slower reaction times and lower response accuracy.

### 3.2 EMPIRICAL WORK II - NUCLEUS ACCUMBENS REACTIVITY TO REWARD DELIVERY IS NEGATIVELY ASSOCIATED WITH MALADAPTIVE EMOTION REGULATION AND DEPRESSIVE SYMPTOMS

The second empirical work is a correlational study linking the striatal responsiveness to reward delivery to both (i) the propensity to use adaptive or maladaptive emotion regulation strategies and (ii) the severity and intensity of subclinical depressive symptoms in healthy adults. As outlined in the theoretical background, the capacity to experience positive emotions in everyday life is essential for well-being. Emerging data indicate that the experience of positive emotions is intrinsically related to the reward responsiveness (Heller et al., 2015). The experience of positive emotions is tightly intertwined with the propensity to engage in motivated behaviors and with the ability to experience hedonic pleasure in response to reward delivery. Nevertheless, little is known about the factors which might contribute to experience functional reward responsiveness and positive emotions. Since maladaptive emotion regulation has been evidenced to hinder the ability to experience positive emotions (Aldao et al., 2010; Frank et al., 2014), the propensity to use maladaptive emotion regulation strategies might constitute a promising vulnerability factor for understanding the etiology of motivation-related disorders including major depression.

In this framework, this second empirical work aimed at exploring how adaptive and maladaptive emotion regulation strategies are associated with the neural responsiveness to the delivery of monetary rewards in healthy adults, with a particular focus on the NAcc activation located in the ventral striatum. Since blunted neural responsiveness to reward, and maladaptive emotion regulation have been evidenced in individuals suffering from major depression (Hasler et al., 2004; Zhang, Chang, Guo, Zhang, & Wang, 2013), a further purpose was to examine how the NAcc reactivity to reward delivery, as well as adaptive and maladaptive emotion regulation strategies are related to depressive symptoms. **First**, we hypothesized that the tendency of healthy adults to use (i) adaptive emotion regulation strategies would correlate with stronger NAcc responsiveness to reward delivery, whereas (ii) maladaptive emotion regulation strategies would be associated with reduced NAcc responsivity to reward delivery. **Second**, we postulated that the intensity and severity of subclinical depressive symptoms in healthy adults would correlate negatively with both (iii) increased NAcc responsiveness to reward delivery, and (iv) higher propensity to use adaptive emotion regulation strategies. In contrast, we expected that subclinical depressive symptoms in healthy adults would be positively associated with (v) stronger propensity to use of maladaptive emotion regulation strategies.

### 3.3 EMPIRICAL WORK III - STRIATAL REACTIVITY TO REWARD UNDER THREAT-OF-SHOCK AND WORKING MEMORY LOAD IN ADULTS AT INCREASED FAMILIAL RISK FOR MAJOR DEPRESSION

The purpose of the third empirical work was to use the vulnerability to depression as a clinical model to test the implications of stress exposure and cognitive demands on the reward processing, as risk factors for the development of anhedonic symptoms. Ample evidence documented the pivotal role played by an abnormal reward processing in the symptomatology of MDD (e.g. Epstein et al., 2006; Pizzagalli et al., 2009), and that dysfunction of the reward system might constitute a crucial biomarker of increased vulnerability to MDD (W. Liu et al., 2016). Stress exposure is another risk factor in the etiological pathway leading to MDD, with data showing the critical influence of stressful life events in the occurrence of a first depressive episode (Kendler & Gardner, 2016; for a review see: R. T. Liu & Alloy, 2010) and in relapse (Beshai et al., 2011; see for a review: Buckman et al., 2018). However, little is known so far about how both factors interact and under which conditions they might contribute to MDD symptomatology. Among pivotal candidate factors that contribute to the etiology and pathophysiology of MDD, cognitive deficits are common and might potentially reflect negative cognitive biases (Beevers, 2005; Clark & Beck, 2010; for a review see: Leppänen, 2006; Peckham et al., 2010). For instance, MDD patients show higher difficulty to inhibit irrelevant negative information or to allocate flexibly their attentional focus to relevant contents in comparison with healthy controls (for a review see: Marazziti et al., 2010). This cognitive dysfunction is thought to result in distorted cognitive biases underpinning the development and maintenance of depressive symptoms (Everaert, Duyck, & Koster, 2015; Everaert, Grahek, & Koster, 2017). However, little data exist so far on how stress exposure affects the reward processing in individuals at increased familial risk for MDD, and how cognitive effort modulates the effects of stress exposure on reward processing.

With the aim to fill this gap, our third empirical work investigated whether the effect of stress exposure affects differentially the striatal reactivity to rewards in HV compared to HC during the anticipation and delivery phases. Additionally, we examined, in an exploratory way, whether the cognitive effort modulates differentially the effect of stress exposure on the striatal reactivity to rewards in HV compared to HC during both phases. **First**, we assumed that in HC, (i) stress exposure would heighten striatal reactivity to reward cues during the anticipation phase, and would reduce striatal responsiveness to rewards during the delivery phase. **Second**, we expected that in HV, (ii) stress exposure would decrease striatal reactivity to rewards during both the reward anticipation and the reward delivery. **Third**, at the behavioral level, we expected that (iii) cued reward during anticipation would strengthen WM performance by increasing response accuracy

and by speeding up reaction times, with higher enhancing effect of cued reward in HC compared to HV. **Fourth**, we hypothesized that (iv) stress exposure would counteract the enhancing effect of reward on WM performance in both HC and HV, as indicated by decreased response accuracy and slower reaction times.



# CHAPTER 4

## METHODS

---

# METHODS

---

This chapter describes the recruitment and selection of the participants for the three empirical works presented in this thesis (section 4.1), the design of these empirical works (section 4.2), the procedure implemented (section 4.3), the experimental task and measurements included (section 4.4), the data analyses (section 4.5), the analyses performed in the additional data exploration (section 4.6), and the ethics (section 4.7).

## 4.1 PARTICIPANTS

### 4.1.1 Recruitment

A total of 154 individuals were screened from the local community through advertisements and from psychology courses at the University of Fribourg, Fribourg, Switzerland. *Empirical works I and II* focused specifically on healthy adults, whereas *Empirical work III* explored the differences between healthy adults without (HC, healthy controls) and with (HV, healthy vulnerable) increased familial vulnerability to MDD. After eligibility assessment and exclusion before analysis, twenty-three healthy adults were included in *Empirical works I and II*. In *Empirical work III*, 16 out of the 23 HC and 16 HV were closely matched with respect to age, gender, and socioeconomic status. Among the HV sample, 11 participants reported having a mother with a history of MDD, 3 participants a father, and 1 participant with both parents having a history of MDD. Fifteen out of the 16 HV cohabitated with their parents at the time of parental MDD history, with length of cohabitation ranging from 1 to 19 years. An illustration of the recruitment process is presented in Figure 4.1 and participants' characteristics are summarized in Table 4.1.



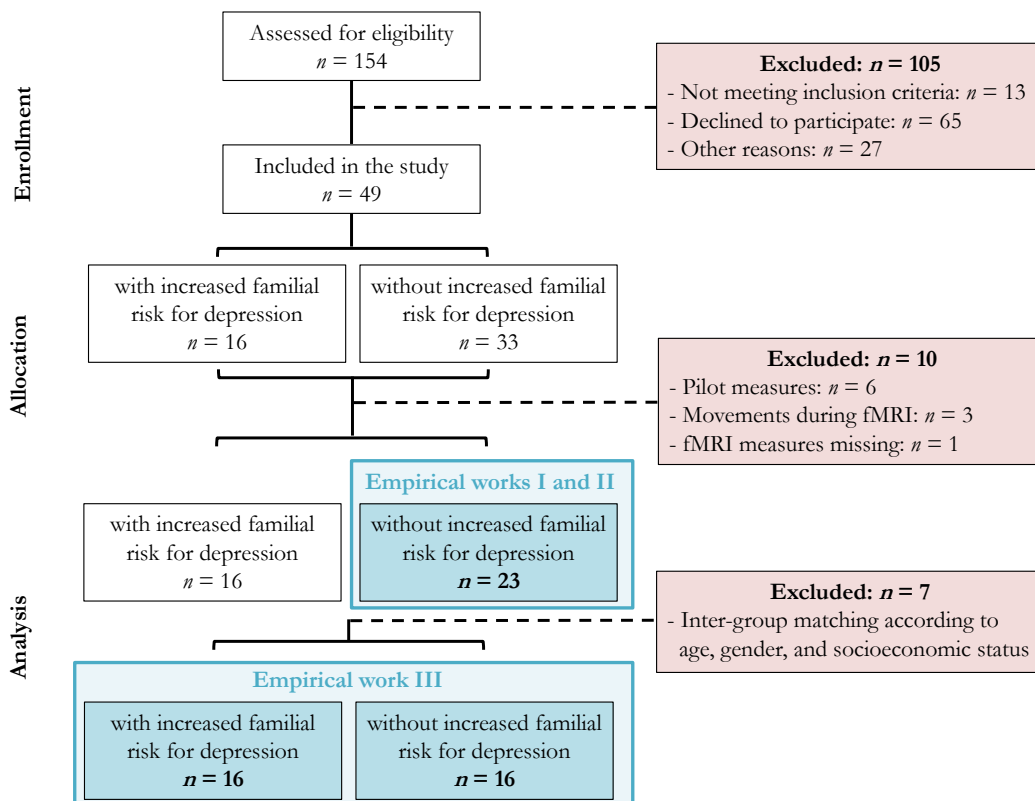

Figure 4.1. Process for recruiting participants and participants' allocation for each empirical work.

#### 4.1.2 Inclusion and exclusion criteria

**General inclusion criteria** encompassed being aged between 18 and 40 years old, right-handed, non-smoking, and having a good command of French. For the participants enrolled in the group with increased familial vulnerability to MDD (HV, healthy vulnerable), additional inclusion criteria were having a biological parent with a current or past history of MDD (as assessed by the Family Interview for Genetic Studies, FIGS; Maxwell, 1992).

**General exclusion criteria** comprised current pregnancy, current or past neurological disorder, brain injury, endocrinological condition, mental disorder, use of psychotropic drugs including alcohol, nicotine, medicines (as assessed by the Mini-International Neuropsychiatric Interview; Sheehan et al., 1998). In addition, general contra-indications regarding the participation in a study including resonance imaging measures were exclusion criteria (e.g. pregnancy, pacemaker, mechanical heart valve, metal implant). For the participants enrolled in the healthy control (HC) group, additional exclusion criteria encompassed having a biological parent with a current or past history of mental disorder (as assessed by the FIGS; Maxwell, 1992).

Table 4.1

*Participants' characteristics, and scores on questionnaires evaluating depressive symptoms and emotion regulation strategies*

	Empirical works I and II			Empirical work III												
	23 HC (9 males, 14 females)			16 HC (4 males, 12 females)			16 HV (4 males, 12 females)			16 HC vs 16 HV						
	<i>M</i>	<i>SD</i>	<i>SE</i>	<i>M</i>	<i>SD</i>	<i>SE</i>	<i>N</i>	<i>Range</i>	<i>M</i>	<i>SD</i>	<i>SE</i>	<i>df</i>	<i>T-value</i>	<i>p-value</i>	<i>Mann-Whitney U</i>	<i>p-value</i>
Age	24.7	4.3	0.9	24.1	3.7	0.9	-	-	24.3	4.1	1.0	30	-0.18	.86	119.5	0.75
IPSE	57.9	16	3.4	57.1	15.9	4.0	-	-	58.2	17.1	4.3	30	-0.19	.85	102.0	0.33
Age at parental MDD onset	-	-	-	-	-	-	-	0 to 25	11.8	8.3	2.4	-	-	-	-	-
Cohabitation with a depressed parent	-	-	-	-	-	-	15	-	-	-	-	-	-	-	-	-
Length (years) of cohabitation with a depressed parent	-	-	-	-	-	-	-	1 to 19	7.6	6.5	1.9	-	-	-	-	-
MADRS	3.6	4.0	0.9	4.3	4.4	1.1	-	-	3.8	2.8	0.70	30	0.39	0.70	121.5	0.81
BDI-II mean scores	4.8	4.9	1.0	5.1	5.4	1.4	-	-	6.7	6.8	1.71	30	-0.74	0.46	107.5	0.43
CERQ mean scores																
Adaptive ERS	14.4	2.7	0.6	14.5	2.6	0.7	-	-	14.9	3.2	0.8	30	-0.47	.65	-	-
Maladaptive ERS	8.5	2.0	0.4	8.8	2.1	0.5	-	-	7.9	2.0	0.5	30	1.12	.27	-	-
Shock intensity level	106.7	42.6	8.9	102.8	39.5	9.87	-	-	99.6	24.4	6.11	30	0.28	.79	-	-

*Note.* Before starting the scanning session, each participant performed a standard workup procedure to establish their individual shock intensity level. Shock intensity levels range from 0 to 255, with a score of 255 corresponding to 5 milliamperes. BDI-II, Beck Depression Inventory II ; CERQ, Cognitive Emotion Regulation Questionnaire ; ERS, emotion regulation strategies ; *df*, degree of freedom ; HC, healthy control (first-degree relative of parents without history of mental disorders); HV, healthy vulnerable (first-degree relative with a parent having a history of major depression) ; IPSE, Indice de Position SocioEconomiq (Index of Economic Status Position according to the Swiss Population) ; *M*, mean ; MDD, Major Depression Disorder; *N*, number of HV cohabitating with a depressed parent; *SD*, standard deviation ; *SE*, standard error ; *T*-value, Test of Student.

## 4.2 STUDY DESIGN

The three empirical works presented in this thesis are based exclusively on data collected cross-sectionally. Measurements were scheduled over one week and comprised an initial interview to assess eligibility to enter the project, fMRI data acquisition during the completion of an event-related experimental task, the collection of cortisol samples during the scanning session to assess biological stress responses, the completion of self-reported questionnaires evaluating psychological variables and a final interview at the end of measurements. All participants performed every measurement. Data acquisition started in June 2015 and ended up in February 2016. As illustrated in Figure 4.1, the first and second empirical works presented in this thesis include data of 23 healthy adults (see Chapter 5 and Chapter 6), whereas the third empirical work focuses on data collected in 16 HC and 16 HV participants matched for age, gender, and socioeconomic status (see Table 4.1 for a description of participants' characteristics).

## 4.3 PROCEDURE

Participants performed all measurements over a duration of approximately one week. At the entrance of the project, we conducted a first interview to inform thoroughly participants about the study procedure, to assess their eligibility to take part to the study and to ensure that they met inclusion criteria. This first interview encompassed the administration of the Family Interview for Genetic Studies (FIGS; Maxwell, 1992) to collect current and past history of familial mental disorders, two diagnostic interviews comprising the Mini-International Neuropsychiatric Interview (M.I.N.I.; Sheehan et al., 1998) and the Montgomery and Asberg Depression Rating Scale (MADRS; Montgomery & Asberg, 1979) to evaluate past or present history of mental disorder in participants, and finally the Edinburgh Handedness Inventory (EHI; Oldfield, 1971) to ensure that all participants were right-handed. At the end of this initial interview, eligible subjects who met the inclusion criteria and who agreed to participate signed the informed consent and a study visit was scheduled. The study visit took place at the Department of Diagnostic and Interventional Neuroradiology of the University Hospital of Bern, Switzerland. The study visit included the acquisition of structural, functional, and resting-state MRI data. Throughout fMRI data acquisition, participants performed an event-related experimental task during which salivary cortisol samples were collected for assessing biological stress reactivity. On the same day, participants received a link by e-mail for the completion of self-reported computerized questionnaires at home. Participants completed 23 questionnaires in total. A final clinical interview closed up the participation to the study by evaluating the potential emergence of psychological distress in

participants. Measurements included in the *Empirical works I, II and III* presented in this thesis are illustrated in Figure 4.2 and comprised (i) fMRI data, (ii) behavioral data, and (iii) salivary cortisol measures collected during the event-related fMRI task, as well as (iv) four self-reported questionnaires assessing the depressive symptomatology, emotion regulation strategies, socioeconomic status, and handedness.

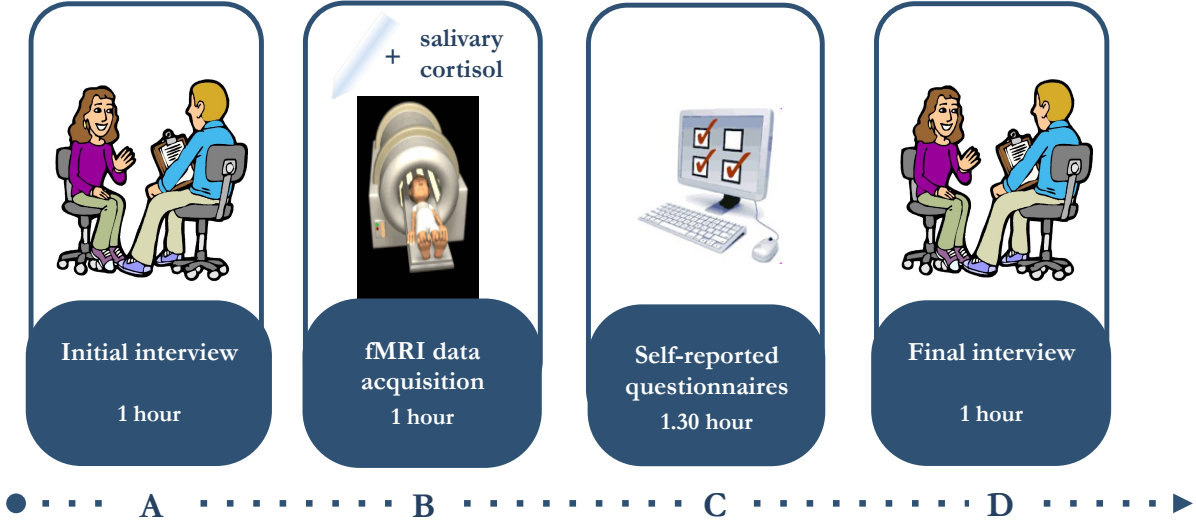

Figure 4.2. Illustration of measurements collected in all participants. (A) Before entering the study, an initial interview (1 hour) was conducted to assess subjects’ eligibility and inclusion criteria. (B) During the study visit, participants performed an experimental event-related task with fMRI data acquisition and collection of salivary cortisol samples throughout the scanning session (1 hour). (C) At home, participants completed computerized self-reported questionnaires (1.30 hour). (D) Participants underwent a final interview which closed up the participation in the study.

## **4.4 MEASURES**

This section introduces the measures collected for this thesis. The subsections describe the clinical interviews (subsection 4.4.1), the four self-reported questionnaires included in our empirical works (subsection 4.4.2), the Fribourg reward task completed during the fMRI data acquisition (subsection 4.4.3), the acute experimental stress induction (subsection 4.4.4), and the magnetic resonance imaging (subsection 4.4.5).

### **4.4.1 Clinical interviews**

The short structured Mini-International Neuropsychiatric Interview (MINI ; Sheehan et al., 1998) was conducted for assessing psychiatric disorders according to the Diagnostic and Statistical Manual of Mental Disorders, fourth edition (DSM-IV-TR; American Psychiatric Association, 2000), and ensure that the inclusion criteria stipulating the absence of any current or past disorder were met. Additionally, the short structured Montgomery and Asberg Depression Rating Scale (MADRS; Montgomery & Asberg, 1979) was administered to evaluate accurately the presence of depressive symptoms and their severity. This scale comprises 10 items scored from 0 to 6, with the total score ranging from 0 ‘no depressive symptom’ to 60 ‘severe depressive symptoms’, with a score threshold of 15 or above indicating the presence of a major depressive episode (Bouvard & Cottraux, 2010). Finally, the Family Interview for Genetic Studies (FIGS; Maxwell, 1992) assessed the presence of current or past psychiatric DSM-IV-TR disorders in family relatives of the participant. It was also used to validate the current or past history of MDD in biological parent of participants enrolled in the group with increased familial vulnerability to MDD.

### **4.4.2 Self-reported questionnaires**

#### **4.4.2.1 Socioeconomic status**

The Indice de Position SocioEconomique scale (IPSE; Genoud, 2011) provides a good estimation of the individual’s socioeconomic position relatively to the Swiss population. This scale indicates the age, education achievement (educational level completed), and occupational category of the participant. Specifically, five socioeconomic positions are distinguished : lower class (scores ranging from 1 to 35), lower-middle class (scores ranging from 36 to 54), middle class (scores ranging from 55 to 67), upper-middle class (scores ranging from 68 to 80), and upper class (scores higher than 80).

#### **4.4.2.2 Handedness**

To ensure that participants were right-handed, the short version of the Edinburgh Handedness Inventory (Veale, 2014) was used to evaluate the lateralized behaviors with scores scaling from -2 'always left' to +2 'always right'. This 4-item scale assesses the lateralized behaviors including writing a, throwing, using a toothbrush, and using a spoon. This scale showed high internal consistency with a coefficient alpha of .93 (Williams, 1991).

#### **4.4.2.3 Depressive symptoms**

Depressive symptoms were captured with the Beck Depression Inventory-II scale (BDI-II; Beck, Steer, & Brown, 1996, French version: 1998). This 21-item questionnaire assesses the intensity and severity of depressive symptoms over the past two weeks, with items scored on a 4-point Likert-like scale. Ranged from 0 to 63, the total score is computed by summing up each item's score. Higher scores indicate stronger intensity and severity of depressive symptoms. For guidance, cut-off scores were established for the French version with total scores ranging from 0 to 11 indicating the absence of major depressive episode, from 12 to 19 a mild depressive episode, from 20 to 27 a moderate depressive episode, and above 27 a severe depressive episode (Bouvard & Cottraux, 2010). Widely validated in the general and clinical populations, this standardized scale reported high reliability and internal consistency, as evidenced for instance in healthy young adults with Cronbach's alpha coefficient equal to .89 (Whisman, Perez, & Ramel, 2000).

#### **4.4.2.4 Cognitive emotion regulation strategies**

Emotion regulation strategies were evaluated with the Cognitive Emotion Regulation Questionnaire (CERQ; Garnefski & Kraaij, 2007; French version: Jermann, Van der Linden, d'Acremont, & Zermatten, 2006). The CERQ is a standardized multidimensional questionnaire assessing the use of nine conceptually separate cognitive emotion regulation strategies including acceptance, positive refocusing, refocusing on planning, positive reappraisal, perspective taking, self-blame, rumination, catastrophizing, and blaming others. This 36-item scale is rated on a 5-point Likert-like scale ranging from 1 'almost never' to 5 'almost always'. A score is calculated for each of the nine cognitive emotion regulation strategies by summing up the scores on the 4 items constituting the subscale, with the total score on each cognitive emotion regulation strategy ranging from 4 to 20. A global score can be computed for assessing the tendency to use adaptive and maladaptive emotion regulation strategies. The global score of adaptive emotion regulation strategies is computed by calculating the average score of the following cognitive emotion

regulation strategies: acceptance, positive refocusing, refocusing on planning, positive reappraisal, and putting into perspective. In turn, the global score of maladaptive emotion regulation strategies is computed by calculating the average score of the following cognitive emotion regulation strategies: self-blame, rumination, catastrophizing, and blaming others. Therefore, global scores on both adaptive and maladaptive emotion regulation strategies range from 4 to 20. The French version demonstrated good psychometric properties including factorial validity and internal reliabilities among the nine subscales with Cronbach's alpha coefficients ranging from .68 to .87 (Jermann et al., 2006). Additionally, the scores of adaptive and maladaptive emotion regulation strategies' dimensions showed high internal consistency, with Cronbach's alpha coefficient of .89 and .82, respectively (Jermann et al., 2006).

#### **4.4.3 Fribourg reward task**

The Fribourg reward task was adapted from the reward task developed by Martin-Soelch et al. (2009) to assess behavioral performance during a spatial delayed response task in humans, in which different reinforcement schedules and varying levels of cognitive load were manipulated. Previous studies indicated that both monetary reinforcement and the level of cognitive load influenced behavioral performance in healthy controls, as evidenced by increased reaction times under high (7 circles to remember) compared to low (3 circles to remember) cognitive effort, but exclusively in absence of monetary reinforcement (Martin-Soelch et al., 2009). Initially elaborated by Glahn and colleagues (2002), the use of a spatial delayed response task intended to capture the behavioral and neural processes involved in the maintenance of spatial information in WM. Specifically, Glahn and colleagues (2002) manipulated different WM load by varying the number of circles to remember (i.e. 3, 5, or 7 circles) to study the engagement of a set of brain regions involved usually in spatial WM and the effects of increasing load on behavioral performance (see section 2.2.2.1 for more detailed results). Additionally, higher WM load resulted in a stronger engagement of prefrontal regions typically involved in spatial WM such as the dlPFC, ventrolateral PFC, ACC, posterior parietal cortex, and the frontal eye fields.

Based on these previous findings, the Fribourg reward task combines a spatial delayed response task with different reinforcement schedules (not-rewarded, rewarded) and two varying levels of WM loads (low and high) differentiated by the amount of circles to be remembered. With the aim of modulating experimentally stress responses in participants, the Fribourg reward task included two distinct blocks. The first block was devoid of acute experimental stress induction (control condition), the second block comprised acute experimental stress induced by the

administration of unpredictable mild electric shocks (stress condition). In total, the task comprised 96 trials, 48 in each block. All four type of trials (reward  $\times$  load) were randomly distributed within each block. At the onset of each trial, a visual cue (1500 ms) was displayed on the screen and informed the participants about the level of WM effort to expend (3 circles for low, 7 circles for high) and the amount of monetary reward (“\$\$” displayed for rewarded trials, “blank screen” for non-rewarded trials) that they could win if they performed successfully. After a fixation cross (500 ms), an array of yellow circles (1500 ms) was presented on the screen followed by a second fixation cross (3000 ms). After this memorization time, the visual target (one green circle, 1500 ms) appeared at any position on the screen. Participants were asked to decide as quickly and accurately as possible whether the green circle was located at the same position as one the yellow circles presented previously. After participants responded or after the response time elapsed, the green circle was replaced by a variable jittered inter-stimulus-interval (blank screen, 0 ms or 2000 ms) followed directly by the feedback screen (1000 ms). The feedback screen informed the monetary gain (“blank screen” for non-rewarded trials; “1 CHF” for rewarded trials). In rewarded trials, a last screen (1000 ms) indicated the cumulated amount of monetary gains, while a blank screen was displayed in non-rewarded trials. Correct responses were associated with monetary gains (1 CHF) in the rewarded condition, while correct responses resulted in no monetary gain (0 CHF) in the non-rewarded condition. Every four trials, participants were asked to appraise, within 20 seconds, their level of mood (ranging from 0 ‘very negative mood’ to 9 ‘very positive mood’) and of stress (ranging from 0 ‘not stressed at all’ to 9 ‘very stressed’). Before entering the scanner and starting the event-related experimental task, the participants performed a training outside the scanner to get used to the task. Additionally, they were informed that they would receive the total sum earned in cash at the end of the scanning session. The timing of the events for a rewarded and a non-rewarded trial is detailed in Figure 4.3.



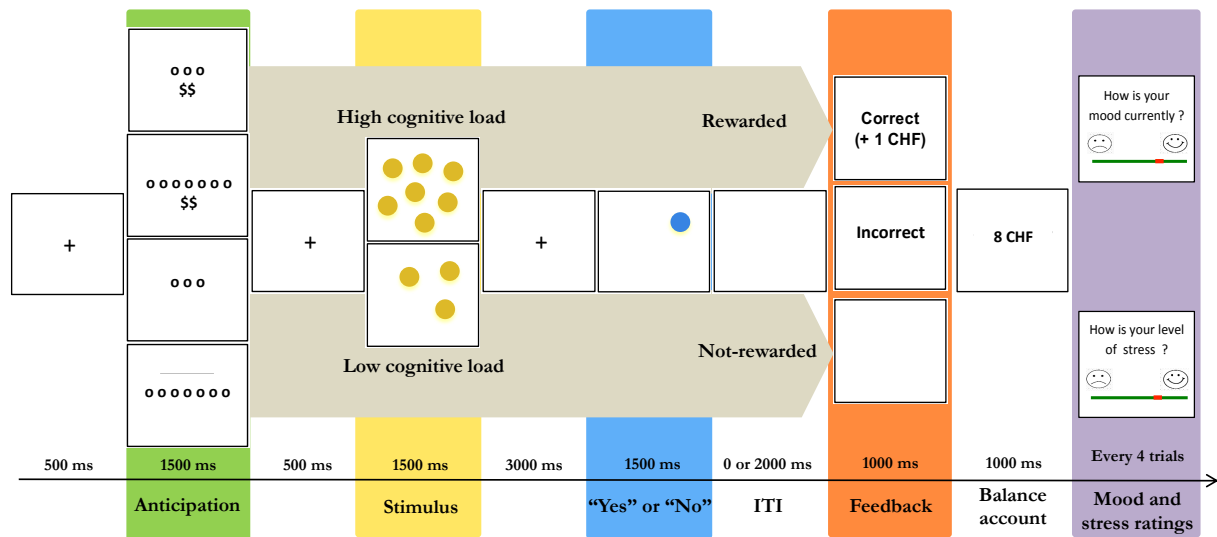

Figure 4.3. Fribourg reward task. Illustration of the four types of trials (reward × load) randomly distributed in the control and stress conditions.

#### 4.4.4 Acute experimental stress induction

To manipulate the biological stress response experimentally, a physical acute stress was induced by threat-of-shock during the Fribourg reward task. Before starting the task, participants were informed that they could receive electrical shocks at any time during the stress condition (i.e. second block). Specifically, participants were delivered six unpredictable mild electric shocks on the external side of their non-dominant left hand using 6-mm Ag/AgCl electrodes whose wires were connected to a non-ferromagnetic electrical pain stimulation shocker (Psychlab system, Contact Precision Instruments, London, UK) placed on a table next to the scanner. Formerly, the Fribourg reward task distinguished three different reward magnitudes in the reward condition including not-rewarded trials (0 CHF), low-rewarded trials (0.10 CHF) and high-rewarded trials (1 CHF), combined with two levels of WM load (low, high) resulting in six types of trials (not-rewarded/low load, not-rewarded/high load, low-rewarded/low load, low-rewarded/high load, high-rewarded/low load, high-rewarded/high load). One electrical shock was delivered in each of the six types of trials comprised in the stress condition, during six different time points of the trial. A first shock was delivered during the cue presentation (anticipation) in the high-rewarded/low load condition, a second during the stimulus presentation in the low-rewarded/low load condition, a third during the memorization (i.e. fixation cross between the stimulus and target presentations) in the high-rewarded/high load condition, a fourth during the target presentation in the not-rewarded/high load condition, a fifth during the feedback presentation (feedback delivery) in the low-rewarded/high load condition, and a sixth during the self-reported ratings in the not-

rewarded/low load condition. Moreover, the order of electrical shock delivery was counter-balanced across participants.

Preceding the scanning session, each participant was administered a standard workup procedure to establish the individual shock intensity. The participants were told that the electrical shock delivery should be uncomfortable, but not painful. During the standard workup procedure, the start level of the electrical shock delivered for testing the participant's tolerance level was set at the value 15. The electrical shock levels ranged from 0 to 255, with the highest intensity level corresponding to an electrical shock of 5 milliamperes. The duration of the mild electrical shock delivery was constantly set at 0.1 second. The administration of electrical shocks is a well-validated experimental manipulation for inducing an effective biological stress response in animal and human (Grillon & Ameli, 1998; for a review see: Grillon & Baas, 2003). Notably, this widely used method was evidenced to induce consistently physiological arousal and higher cortisol levels together with a subjective state of anxiety and negative mood in participants (Balderston, Hale, et al., 2017; Balderston, Vytal, et al., 2017; Bogdan & Pizzagalli, 2006; J. M. Choi et al., 2015; Grillon, Ameli, Foot, & Davis, 1993; Torrisi et al., 2018).

#### **4.4.5 Magnetic resonance imaging**

A 3.0 Tesla whole-body MRI system (TrioTim syngo, Siemens, Erlangen, Germany) equipped with a 32-channel head coil was used for collecting the functional MRI (fMRI) data presented in this thesis. The scans were performed at the Department of Diagnostic and Interventional Neuroradiology of the University Hospital of Bern, Switzerland. In order to check the presence of potential relevant pathologies, a neuroradiologist inspected the T1-weighted structural MRI of each participant. The scanning session lasted approximately 60 minutes and included (i) task-based functional MRI, (ii) T1-weighted images (structural MRI), and (iii) resting-state functional MRI. The empirical works presented in this thesis concentrate on the task-based MRI data whose acquisition is detailed here after together with the acquisition of the T1-weighted structural images.

#### **4.4.5.1 Task-based functional magnetic resonance imaging**

fMRI data were collected using an echo-planar imaging (EPI) pulse sequence to acquire 38 interleaved ascending slices with the following settings: FOV:  $192 \times 192$  mm ; flip angle:  $90^\circ$ ; matrix size:  $64 \times 64$  ; TR: 2000 ms ; TE: 30 ms ; voxel size:  $3.0 \times 3.0 \times 4.0$  mm<sup>3</sup>. The task-based fMRI data were acquired during two event-related blocks, lasting each approximately 20 minutes. Stimuli presented in the computerized experimental task were displayed via goggles (VisualStimDigital MR-compatible video goggles; Resonance Technology Inc., Northridge, CA, USA) with a visual angle of  $60^\circ$ , a resolution of  $800 \times 600$  pixels, and 60 Hz refresh rate. The experimental task was programmed and run with the software E-Prime (Version 2.0.10.353, Psychology Software Tools, Inc.).

#### **4.4.5.2 T1-weighted images**

Structural images were collected using a 3D T1-weighted magnetization-prepared rapid acquisition gradient echo sequence (MPRAGE) resulting in 176 slices in the sagittal plane, FOV: 256 mm x 256 mm, flip angle:  $8^\circ$ , matrix size:  $256 \times 256$ , TR: 2300 ms ; TE: 2.32 ms, voxel size:  $1.0 \times 1.0 \times 1.0$  mm<sup>3</sup>.

## 4.5 DATA ANALYSES

This section describes briefly the statistical methods used to analyse the behavioral and fMRI data presented in our three empirical works. Detailed data analyses specific to each empirical work are introduced in the section 5.3 for *Empirical work I*, section 6.3 for *Empirical work II*, and section 7.3 for *Empirical work III*.

### 4.5.1 Behavioral data analyses

#### 4.5.1.1 Working memory performance during the Fribourg reward task

Repeated measures analyse of variance (ANOVA) was run using the Statistical Package for the Social Sciences (SPSS; IBM SPSS Statistics, Version 25.0, Armonk, NY, USA) on reaction times and response accuracy during the Fribourg reward task. Stress exposure (stress vs control), reinforcement (rewarded vs not-rewarded), and cognitive load (high vs low) were entered as within-subject factors. In *Empirical work III*, group (HV vs HC) was entered as between-subject factor to test the differential effect of stress, reinforcement, and cognitive load on reaction times and response accuracy in HV compared to HV.

#### 4.5.1.2 Self-reported mood and stress ratings during the Fribourg reward task

In *Empirical work I*, we computed the difference between self-reported ratings during the control condition and the stress condition of the Fribourg reward task to test the effect of stress exposure on self-reported mood and stress ratings. A Wilcoxon signed ranks test was applied using SPSS (IBM SPSS Statistics, Version 25.0, Armonk, NY, USA). In *Empirical work III*, we used repeated measures ANOVA implemented in SPSS (IBM SPSS Statistics, Version 25.0, Armonk, NY, USA) to test the within-subject effect of stress exposure (stress vs control), reinforcement (rewarded vs not-rewarded), and cognitive load (high vs low) on self-reported mood ratings. Group (HV vs HC) was entered as between-subject factor to test the differential effect of stress, reinforcement, and cognitive load on self-reported mood ratings in HV compared to HC.

## 4.5.2 fMRI data analysis

The preprocessing and statistical analyses of the structural and functional MRI data were performed with Analysis of Functional NeuroImages software package (AFNI; Cox, 1996).

### 4.5.2.1 fMRI data preprocessing

T1-weighted (MPRAGE) images were first processed with FreeSurfer pipeline, version 6.0.0 (Fischl, 2004) to obtain segmentation masks corresponding to the skull-stripped brain, white matter, and ventricles. The EPI images were preprocessed according to the following steps using the *afni\_proc.py* script: despiking the time-series (despike), correcting for slice timing (tshift), volume co-registering to the participants' corresponding anatomical (MPRAGE) image (align), volume registration across the timeseries (volreg), and normalization (scale). The preprocessed EPI timeseries were warped to Montreal Neurological Institute (MNI) space using the ICBM 2009a Nonlinear Symmetric atlas (Fonov, Evans, McKinstry, Almlí, & Collins, 2009), and spatially smoothed with an isotropic 6 mm full-width half maximum Gaussian kernel. Binary masks were averaged to create a group-level grey matter mask thresholded at 0.75, i.e. 75% overlap (Torrìsi et al., 2015). Subjects with significant motion exceeding 3 mm were excluded from further analysis. Additionally, we used motion parameters from each block as separate regressors. To correct for motion, any EPI volume with an Euclidean mean of 0.3 mm shift from its preceding volume was censored from regression together with its preceding volume. Exclusion for motion at subject-level was based on the 0.3 mm censoring. Moreover, volumes with more than 10% of (motion-based) voxel outliers were censored. Subjects with more than 10% censored volumes were excluded from analysis.

### 4.5.2.2 fMRI data analysis

Individual subject regressions were performed within the framework of the general linear model (GLM), as implemented in the AFNI program *3dDeconvolve*. Statistical analyses were focused on the reward anticipation phase during cue presentation and on the reward delivery phase during feedback presentation. At the subject level, all the events defined from the experimental design and the six residual motion parameters for each block (control condition and stress condition) were regressed on the processed time series. The event were coded by onset time and the gamma variate function that defined the duration of the event in the modeling. The Fribourg reward task distinguished three different reward magnitudes in the reward condition including a not-rewarded

trials (0 CHF), low-rewarded trials (0.10 CHF) and high-rewarded trials (1 CHF). Therefore, regressors of interest included six anticipation events during the cue presentation (1500 ms) and six feedback delivery events during the feedback and balance account presentation (2000 ms) for both blocks, i.e. the control condition and stress condition. Six working memory events including the stimulus presentation, cross fixation and target presentation (6000 ms) and one self-reported ratings event including self-reported stress and mood (variable duration up to 20'000 ms) were also modeled for both blocks. The anticipation events, working memory events and feedback events were modeled for the six conditions combining reward and load modalities, that are (i) not-rewarded/low load, (ii) not-rewarded/high load, (iii) low-rewarded/low load, (iv) low-rewarded/high load, (v) high-rewarded/low load, (vi) high-rewarded/high load. One regressor was modeled for the self-reported ratings event without distinguishing the different conditions combining reward and load modalities. Six motion parameters were modeled as nuisance variables for both blocks and consisted of three rotational (roll, yaw, pitch) and three translational (x, y, z) variables. These events were convolved with the haemodynamic response function (HRF) using a gamma variate function to form separate regressors in a general linear model. Further, whole-brain statistical *t*-maps based on contrasts of interest were generated individually. Contrasts of interest included four types of trials combining the reinforcement condition with two levels of reward magnitude (not-rewarded, high rewarded) and the WM load condition with two levels of loads (low, high) in the two different blocks of the task including the control and the stress conditions.

Next, group-level analyses tested the interaction between stress (control vs stress), monetary reward (not-rewarded vs rewarded), and WM load (low vs high) as fixed factors, and subjects as a random factor. Analyses concentrated on changes in BOLD contrast that occurred during the anticipation phase signaled by the cue presentation and the feedback delivery phase signaled by the feedback presentation. In *Empirical work III*, group (HV vs HC) was added as between-subject factor to test the differential brain activations in HV compared to HC. To test *a priori* hypotheses, regions-of-interest (ROI) were created using the maximum probability atlas of Desai DKD maps in FreeSurfer (Desikan et al., 2006; Destrieux, Fischl, Dale, & Halgren, 2010; Fischl, 2004). To address the issues of inflated false positive rates identified by Eklund et al. (2016), we corrected whole-brain activation maps for multiple comparisons using a cluster-based approach. At the whole-brain level, significant results were identified using voxel-wise and cluster-size thresholds. The alpha level for individual voxels was set at  $p < .005$  uncorrected. Correction for multiple comparisons was accomplished by establishing an appropriate cluster extent threshold by conducting 10'000 Monte Carlo simulations integrated in the *3dClustSim* AFNI program in order to achieve a corrected alpha level of  $p < .05$ . The updated *3dClustSim* version includes a mixed

autocorrelation function (ACF) that better models non-Gaussian noise structure (Cox, Chen, Glen, Reynolds, & Taylor, 2017). An intersection mask of all subjects was submitted to the *3dClustSim* program with a threshold of voxel of  $p < .005$  and a cluster-size correction of  $p < .05$ . ROI activation analyses were corrected for multiple comparisons by applying a Bonferroni correction. Next, the parameter estimates (beta weights) were extracted from ROI contrast maps by averaging the activation of all voxels located in the ROI for each subject and each condition. Finally, parameter estimates from each ROI were entered into SPSS to perform repeated measures ANOVA.

#### **4.5.3 Correlation analyses between reward-related neural activation and self-reported measures of emotion regulation and depressive symptoms**

In *Empirical work II*, we used Pearson and Spearman correlations to examine whether the neural reactivity during reward delivery was associated with both (i) the propensity of healthy adults to use adaptive or maladaptive emotion regulation strategies, and (ii) the intensity and severity of subclinical depressive symptoms in healthy adults, as well as whether the adaptive or maladaptive emotion regulation strategies were associated with depressive symptomatology in participants.

## 4.6 ADDITIONAL DATA ANALYSES

This section introduces the statistical method used to analyse the salivary cortisol measurements that were not presented in our empirical works. The statistical analyses performed on the salivary cortisol data are described in section 4.6.1, while Chapter 8 presents these additional data analyses.

The salivary cortisol data were collected to control for the effectiveness of the stress induction on the reactivity of the biological stress system. To monitor the biological stress response during the stress condition of the Fribourg reward task via the HPA system, salivary cortisol samples were collected in temporal proximity to the experimental task using a commercially available sampling device (Salivette, Sarstedt, Rommelsdorf, Germany). Participants were requested to abstain from eating and drinking for one hour before arrival at the Department of Diagnostic and Interventional Neuroradiology of the University Hospital of Bern, Switzerland. Specifically, five salivary samples were collected from each participant, starting with the first salivary sampling at the entry into the scanner ( $T_0$ ), between the control and the stress conditions ( $T_1$ ) (i.e. between the first and second blocks of the Fribourg reward task), directly at the end of the stress condition ( $T_2$ ), 10 minutes ( $T_3$ ) and 20 minutes ( $T_4$ ) after the end of the stress condition. The timing of the salivary cortisol sampling is described in Figure 4.4 with the measurement timepoints presented according to the first salivary sample at the entry into the scanner. Following the procedure used in a previous study (Ossewaarde et al., 2011), the cotton swap of the Salivette was carefully placed into the mouth of the participants while they were lying in the scanner in order to remain static in scan position. After approximately two minutes, the swap was collected carefully. All samples were stored at minus 20°C until analysis. Cortisol analyses were performed by the Dresden LabService GmbH, Germany ([www.labservice-dresden.de](http://www.labservice-dresden.de)). After thawing, Salivettes were centrifuged at 3.000 rpm for five minutes, which resulted in a clear supernatant of low viscosity. Salivary concentrations were measured using commercially available chemiluminescence immunoassay with high sensitivity (IBL International, Hamburg, Germany). The intra and interassay coefficients for cortisol were below 8%.



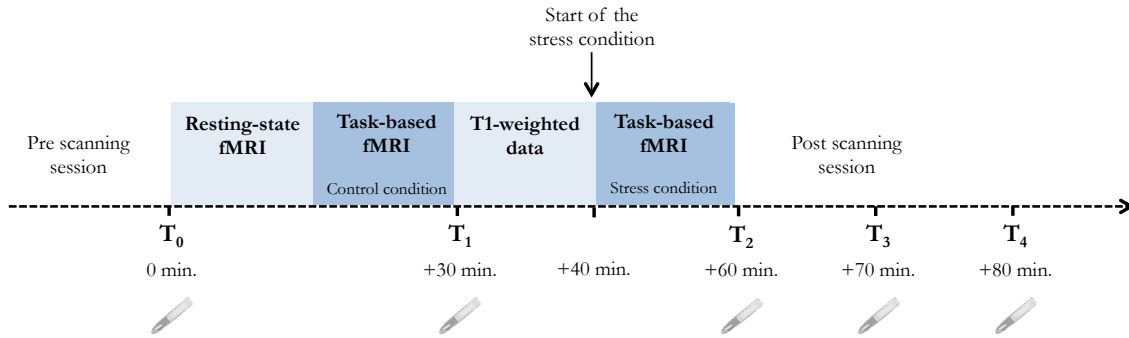

Figure 4.4. Salivary cortisol sampling during the Fribourg reward task. Five salivary samples were collected during the scanning session. A first salivary sample was obtained at the entry into the scanner ( $T_0$ ). After the measurements comprising the resting-state fMRI and the first block (control condition) of the Fribourg reward task, a second salivary sample was collected ( $T_1$ ), a third one at the termination of the second block (stress condition) of the Fribourg reward task ( $T_2$ ), a fourth one 10 minutes ( $T_3$ ) and a last one 20 minutes ( $T_4$ ) after the end of the Fribourg reward task.

#### 4.6.1 Statistical analyses

We used hierarchical linear modeling (HLM, Version 6; Raudenbush, Bryk, Cheong, Congdon, & du Toit, 2002) to analyze the data in order to account for effects of within-subject and between-subject interdependence on cortisol measures. Therefore, the models account for the nonindependence due to repeated measurements for each person by treating repeated measures of cortisol (Level-1) as nested within individuals (Level-2) in a two-level framework. Estimation of cortisol stress reactivity during the Fribourg reward task included four measurement points that occurred 10 min. ( $T_1$ ) preceding the start of the stress condition, and 30 min. ( $T_2$ ), 40 min. ( $T_3$ ) and 50 min. ( $T_4$ ) after the start of the stress condition. Time variable was centered around the cortisol value of the salivary sample collected at  $T_1$ , corresponding to the end of the control condition and to 10 min. preceding the start of the stress condition. This first measurement point represents the salivary free cortisol levels during the control condition of the Fribourg reward task. To approximate a normal distribution of cortisol concentrations (R. Miller, Plessow, Rauh, Gröschl, & Kirschbaum, 2013), we applied a log-transformation, which optimized the normality of the distribution (Skewness and Kurtosis: Z values below 1.96) (Field, 2013; R. Miller et al., 2013). Due to missing salivary cortisol data, the data set of healthy adults who participated in *Empirical works I* and *II* comprised the salivary cortisol samples of 16 participants, while the data set of healthy adults who participated in *Empirical work III* included the salivary cortisol samples of 10 HC and 12 HV. First, to estimate the average overall cortisol level, we tested an empty model without predictors, where  $\text{LogCort}_{ij}$  reflects the  $j^{\text{th}}$  measurement on  $i^{\text{th}}$  participant. Next, we tested a curvilinear growth model to assess a cortisol response marked by an initial increase followed by a decrease across the

last measurements. To this end, the Level-1 model for the prediction of cortisol level ( $\text{LogCort}_{ij}$ ) included a linear and a quadratic time parameters :

Level 1 :

$$\text{LogCort}_{ij} = \pi_{0i} + \pi_{1i} \times \text{TIME}_{ti} + \pi_{2i} \times \text{TIME}_{ti}^2 + \varepsilon_{ij}$$

where  $\pi_{0i}$  represents the individual-specific intercept,  $\pi_{1i}$  the individual-specific linear slope (i.e. the trend of change between  $T_1$  and  $T_4$ ) of estimated cortisol level and  $\pi_{2i}$  the individual-specific quadratic slope (magnitude of the cortisol response between  $T_1$  and  $T_4$ ). Time was coded in minutes (the intercept equates to  $T_1$ ). A significant cortisol response during the stress condition was reflected by a negative quadratic term. On Level-2 (between-subject), we allowed the estimates for the linear time parameters to vary across individuals. Due to the small sample size, the estimate for random variation in the quadratic term ( $r_{2i}$ ) couldn't be included in the analyses. The estimate for random variation in the linear term ( $r_{1i}$ ) captured individual differences in the cortisol response across the measurements. Baseline cortisol levels ( $T_0$ ) showed elevated values, probably due to apprehension regarding the subsequent scanner measurements so that we included measurement at  $T_0$  (baseline cortisol) in the analyses as control variable on Level-2 to prevent potential effects of the pre-stressor cortisol levels across participants. The time of the day was additionally included as control variable to check for potential artifacts induced by timing differences across participants relative to daily cortisol profiles, while gender was entered as a third control variable to take into account potential gender-dependent changes in the biological stress reactivity (Kirschbaum, Kudielka, Gaab, Schommer, & Hellhammer, 1999; for a review see: Kudielka & Kirschbaum, 2005). The model on Level-2 for healthy adults who participated in *Empirical works I* and *II* is described here after:

Level 2 :

$$\pi_{0i} = \beta_{00} + \beta_{01} \times (\text{gender}) + \beta_{02} \times (\text{day time}) + \beta_{03} \times (\text{baseline cortisol}) + r_{0i}$$

$$\pi_{1i} = \beta_{10} + \beta_{11} \times (\text{gender}) + \beta_{12} \times (\text{day time}) + \beta_{13} \times (\text{baseline cortisol}) + r_{1i}$$

$$\pi_{2i} = \beta_{20} + \beta_{21} \times (\text{gender}) + \beta_{22} \times (\text{day time}) + \beta_{23} \times (\text{baseline cortisol})$$

The Level-2 model comparing HV to HC who participated in *Empirical work III* is described here after. In this model, the group was included as additional predictor on Level-2 in the model comparing HV to HC in order to assess for the role played by increased familial vulnerability to depression in the pattern of the stress response during the Fribourg reward task.

Level 2 :

$$\pi_{0i} = \beta_{00} + \beta_{01} \times (\text{group}) + \beta_{02} \times (\text{gender}) + \beta_{03} \times (\text{day time}) + \beta_{04} \times (\text{baseline cortisol}) + r_{0i}$$

$$\pi_{1i} = \beta_{10} + \beta_{11} \times (\text{group}) + \beta_{12} \times (\text{gender}) + \beta_{13} \times (\text{day time}) + \beta_{14} \times (\text{baseline cortisol}) + r_{1i}$$

$$\pi_{2i} = \beta_{20} + \beta_{21} \times (\text{group}) + \beta_{22} \times (\text{gender}) + \beta_{23} \times (\text{day time}) + \beta_{24} \times (\text{baseline cortisol})$$

## 4.7 ETHICS

Permission for conducting this project was granted by the local ethical review board responsible for Vaud and Fribourg regions, Switzerland (CER-VD ; Commission cantonale (VD) d’Ethique de la Recherche sur l’être humain). The study protocol was in line with the ethical principles edicted in the Declaration of Helsinki, all participants were thoroughly informed about the study and provided written informed consent before entering it.



# CHAPTER 5

## EMPIRICAL WORK I

---

### **STRIATAL RESPONSIVENESS TO REWARD UNDER THREAT-OF-SHOCK AND WORKING MEMORY LOAD**

Submitted to *Brain and Behavior*

Claudie Gaillard<sup>1</sup>, Matthias Guillod<sup>1</sup>, Monique Ernst<sup>2</sup>, Salvatore Torrisci<sup>2</sup>, Andrea Federspiel<sup>3</sup>, Dominik Schoebi<sup>4</sup>, Romina E. Recabarren<sup>1</sup>, Xinyi Ouyang<sup>5</sup>, Christoph Mueller-Pfeiffer<sup>6</sup>, Antje Horsch<sup>7,8</sup>, Philipp Homan<sup>9</sup>, Roland Wiest<sup>10</sup>, Gregor Hasler<sup>11</sup>, Chantal Martin-Soelch<sup>1</sup>

<sup>1</sup> IReach Lab, Unit of Clinical and Health Psychology, Department of Psychology, University of Fribourg, Fribourg, Switzerland.

<sup>2</sup> Section on Neurobiology of Fear and Anxiety, National Institutes of Mental Health, Bethesda, USA.

<sup>3</sup> Psychiatric Neuroimaging Unit, Translational Research Center, University Hospital of Psychiatry, University of Bern, Bern, Switzerland.

<sup>4</sup> Unit of Clinical Family Psychology, Department of Psychology, University of Fribourg, Fribourg, Switzerland.

<sup>5</sup> iBM Lab, Department of Psychology, University of Fribourg, Fribourg, Switzerland.

<sup>6</sup> Department of Consultation-Liaison-Psychiatry and Psychosomatic Medicine, University Hospital Zurich, University of Zurich, Zurich, Switzerland.

<sup>7</sup> Department Woman-Mother-Child, Lausanne University Hospital, Lausanne, Switzerland.

<sup>8</sup> Institute of Higher Education and Research in Healthcare, University of Lausanne, Lausanne, Switzerland.

<sup>9</sup> Center for Psychiatric Neuroscience, Feinstein Institute for Medical Research, New York, USA.

<sup>10</sup> Department of Diagnostic and Interventional Neuroradiology, University Hospital of Bern, Bern, Switzerland.

<sup>11</sup> Unit of Psychiatry Research, University of Fribourg, Fribourg, Switzerland.

# EMPIRICAL WORK I

---

## 5.1 ABSTRACT

**Background:** Reward and stress are important determinants of motivated behaviors. Striatal regions play a crucial role in both motivation and hedonic processes. So far, little is known on how cognitive effort interacts with stress to modulate reward processes. This first empirical work examines how cognitive effort (load) interacts with an unpredictable acute stressor to modulate motivational and hedonic processes in healthy adults.

**Methods:** A reward task, involving stress with unpredictable mild electric shocks, was conducted in 23 healthy adults aged 20-37 (mean age:  $24.7 \pm 0.9$ ; 14 females) during fMRI. Manipulation included the use of (1) monetary reward for reinforcement, (2) threat-of-shock as the stressor, and (3) a spatial WM task with two levels of difficulty (low and high load) for cognitive load. Reward-related activation was investigated in a-priori three regions of interest (ROI), the NAcc, caudate nucleus, and putamen.

**Results:** During anticipation, threat-of-shock or cognitive load did not affect striatal responsiveness to reward. Anticipated reward increased activation in the ventral and dorsal striatum. During feedback delivery, both stress and cognitive effort modulated striatal activation. Higher WM load blunted NAcc responsiveness to reward delivery, while stress strengthened caudate nucleus reactivity regardless reinforcement or load.

**Conclusions:** These findings provide initial evidence that both stress and cognitive load modulate striatal responsiveness during delivery but not anticipation. Altogether, they may help to build a framework to understand common stress-related disorders, given that psychiatric disorders involve disturbances of the reward system, cognitive deficits and abnormal stress reactivity.

**Keywords:** reward, stress, working memory, anticipation, delivery, striatum, fMRI.

## 5.2 INTRODUCTION

The ability to detect potential rewards and threats in the environment is fundamental for the survival of humans and animals (Haber & Knutson, 2010). Reward is defined as the positive value that one ascribes to an object, an action, or an internal physical state, and as a value that elicits approach behavior (Schultz, Dayan, & Montague, 1997; Wise, 2004). In contrast, imminent threat stimulates the autonomic nervous system, leading to a “fight-or-flight” response to escape or avoid the aversive situation (McEwen, 2007). When a threat persists over time, uncertainty leads to a sustained state of vigilance or avoidance (Bali & Jaggi, 2015; Grillon, 2008). Therefore, adaptive goal-directed behaviors build on the capacity to attribute a value to both positive and negative stimuli in order to promote approach toward rewards or avoidance of threats (Balleine, Delgado, & Hikosaka, 2007; Fareri & Tottenham, 2016). Although reward-related approach behaviors and threat-related defensive responses are mainly mediated by subcortical systems, the ability to control reactions and actions is modulated by cortical regions involved in cognitive processes, especially WM (Gilbert & Fiez, 2004; LeDoux & Pine, 2016; Pochon et al., 2002).

Research demonstrates the involvement of a corticostriatal circuit in reward processes (Fiallos et al., 2017; Fuentes-Claramonte et al., 2015, p.; Xun Liu et al., 2011; Tanaka et al., 2012). In particular, the striatum, including its ventral and dorsal subdivisions, plays a crucial role in detecting potential rewards and in modulating consecutive reward-driven behaviors (Delgado, 2007; Haber & Knutson, 2010). Part of the ventral striatum (E. Y. Choi, Yeo, & Buckner, 2012), the NAcc is mainly engaged in affective valuation of positive and negative incentives, contributing to motivated actions such as avoidance or approach behaviors in both animals and humans (for a review see: Balleine & Killcross, 2006; Gottfried, O’Doherty, & Dolan, 2003; Pedroni et al., 2011). To date, the role of the ventral striatum in reward anticipation has been widely evidenced both in animals (e.g. Ikemoto & Panksepp, 1999) and humans (Diekhof et al., 2012; Knutson, Adams, Fong, & Hommer, 2001; Knutson et al., 2001; O’Doherty, Deichmann, Critchley, & Dolan, 2002; Rademacher, Salama, Gründer, & Spreckelmeyer, 2014). Its implication has been shown in prediction errors reflecting deviations of received rewards from expected rewards (Hare, Camerer, & Rangel, 2009; Wittmann et al., 2016). With respect to the dorsal striatum, the caudate nucleus and the putamen have been involved in goal-directed behaviors, planning and implementation of actions, respectively (Grahn et al., 2008). These complex processes of motivational and hedonic experiences consist of two temporal phases, (i) reward anticipation and (ii) reward delivery. The former is related to the motivation to obtain a rewarding incentive (i.e., a ‘wanting’ component), whereas the latter represents the hedonic state elicited by the reward delivery (i.e., a ‘liking’ component) (K. C. Berridge, 2009a; K. C. Berridge & Kringelbach, 2013; K. C. Berridge et al.,

2009; Luking et al., 2016). Dysfunctions in reward-seeking and goal-oriented behaviors are common symptoms of several prevalent psychiatric conditions, such as addiction (Koob, 2013; Martin-Soelch, 2013; Nikolova & Hariri, 2012), major depression (Alloy, Olino, Freed, & Nusslock, 2016), eating disorders (Avena & Bocarsly, 2012; Keating, Tilbrook, Rossell, Enticott, & Fitzgerald, 2012) or schizophrenia (Hanssen et al., 2015; G. P. Strauss et al., 2014). Perturbations in the brain systems involved in reward valuation and associated approach behaviors may result in a loss of motivation, interest or pleasure for activities, which were previously rewarding (Admon & Pizzagalli, 2015a; Hägele et al., 2015; Martin-Soelch et al., 2009). Conversely, an imbalance in the neural processing of reward might also contribute to compulsive reward-seeking behaviors, characterized by an uncontrolled desire or pathological motivation for particular rewards (e.g. drugs, food, gambling) (Koob, 2008, 2010; Martin-Soelch, 2013; Martin-Soelch et al., 2001; T. E. Robinson & Berridge, 2000).

Acute stressors are known to alter both the sensitivity to reward (Berghorst et al., 2013; Pizzagalli et al., 2007) and core executive functions (for a review see: Shields, Bonner, & Moons, 2015), in particular WM (Oei et al., 2006; Qin et al., 2009; Zandara et al., 2016). Accordingly, acute stressors can promote severe disruption of reward processing. Acute stressors are defined as time-limited threats to an organism (Pacák & Palkovits, 2001). In experimental settings, acute stressors consist of threats lasting one hour or less (Dickerson & Kemeny, 2004). In turn, chronic stressors refer to sustained or repeated threats over one week or more (Armario, 2015). Unpredictable acute stress elicits anxiety and cognitive deficits (Bali & Jaggi, 2015). Brain imaging data revealed that acute, chronic, and early-life stress exposure altered neural reactivity to reward in animals (Kleen, Sitomer, Killeen, & Conrad, 2006; Lin, Bruijnzeel, Schmidt, & Markou, 2002; Willner, Moreau, Nielsen, Papp, & Sluzewska, 1996) and humans (Berghorst et al., 2013; Boecker et al., 2014; Bogdan & Pizzagalli, 2006; Ginty, 2013; Hanson et al., 2015; Porcelli et al., 2012). In humans, experimental acute stressors, such as threat-of-shock or the cold pressor test, were found to impair reward-related neural responses in the ventral striatum during both reward anticipation (J. M. Choi et al., 2014) and feedback delivery (Kumar et al., 2014; Porcelli et al., 2012). Psychosocial stress, induced by the TSSST (Kirschbaum et al., 1993), was shown to blunt reward responsiveness to sexual stimuli during the anticipatory phase (Oei et al., 2014). Blunted brain reactivity to reward under stress was supported at the behavioral level, with decreased reward-based performance in individuals with increased perceived stress in daily life (Pizzagalli et al., 2007). In contrast, studies also showed enhanced striatal responses to reward under social stress, in particular during the anticipation of monetary reward (Kumar et al., 2014) and of primary rewards (i.e., food) (Pool et al., 2015). This is in line with the hypothesis that under stressful conditions, rewards may be sought for the stress-



reducing capacity associated with their consumption (K. C. Berridge & Robinson, 1998; Koob & Le Moal, 2001). However, taken together, these inconsistent findings call for a better understanding of the factors involved in the modulation of stress-related effects on reward responsiveness during both anticipatory and delivery processes.

The cognitive effort to expend for obtaining the reward is a crucial factor that might modulate the effect of stress on motivational and hedonic processes, both in experimental settings and in everyday life. In daily life, stressful contexts often accompany demanding tasks, requiring high attentional resources. To achieve a better understanding of how stress and cognition interact to modulate the reward processes, it is necessary to determine how each of these factors per se influences motivation and hedonic experience. Previous research has focused on the complex relationship between cognition, motivation, and hedonic capacities (Akaishi & Hayden, 2016; Esterman et al., 2016; O'Connor, Rossiter, Yücel, Lubman, & Hester, 2012; Rothkirch, Schmack, Deserno, Darmohray, & Sterzer, 2014). So far, evidence suggests that executive functions, and more specifically WM, play a critical role in motivational and hedonic processes (Yee & Braver, 2018). The WM, defined as the capacity for temporarily maintaining and manipulating information (Baddeley, 2010; Collette & Van der Linden, 2002), is a particularly relevant cognitive function to investigate because of its broad implications in learning, reasoning, valuating, planning goal-directed behavior and regulating adaptively emotions (Collette & Van der Linden, 2002; Etkin et al., 2015; Gilbert & Fiez, 2004; Pochon et al., 2002).

So far, researchers have taken an active interest in investigating (i) the role of stress on reward responsiveness (Berghorst et al., 2013; Boecker et al., 2014; Bogdan & Pizzagalli, 2006; Ginty, 2013; Hanson et al., 2015; Porcelli et al., 2012) and (ii) the relationship between cognition and motivation (Botvinick, Huffstetler, et al., 2009; Satterthwaite et al., 2012; Vassena et al., 2014). Here, we used an event-related fMRI task to test how unpredictable acute stressor (threat-of-shock) modulates reward responsiveness under variable levels of cognitive effort (WM load) exerted for obtaining a monetary reward. Based on previous research, we hypothesized that the unpredictable acute stressor would increase striatal reactivity to cued reward during anticipation, and would blunt striatal reactivity to reward during feedback delivery. Additionally, we expected that high WM load would counteract the enhancing effect of stress on striatal reactivity to reward anticipation, but would strengthen the blunting effect of stress on the striatal reactivity to reward delivery. At the behavioral level, we hypothesized that both the unpredictable acute stressor and the higher cognitive load would reduce performance (as reflected by a slower reaction time and a decreased response accuracy), thus acting synergistically.

## **5.3 MATERIALS AND METHODS**

### **5.3.1 Participants**

After exclusion for excessive motion during the scanning session, twenty-three out of twenty-six healthy adults (14 women, mean age:  $24.7 \pm 0.9$ , aged 20-37 years) were included in our analyses carried out in this study. Socioeconomic status was average relative to the Swiss population according to the index for individual socioeconomic level (IPSE; Genoud, 2011) (mean IPSE:  $57.9 \pm 3.4$ ). Participants reported no current or past psychopathology, as well as no use of psychoactive drugs, as assessed by the M.I.N.I. (Sheehan et al., 1998). In addition, no history of neurological or endocrine diseases was present among the sample.

### **5.3.2 General procedure**

The local ethical review board (CER-VD ; Commission cantonale (VD) d’Ethique de la Recherche sur l’être humain) approved this study and all participants provided written informed consent. Before entering the scanner, the participants were trained on the task. The fMRI scanning session was performed at the Department of Diagnostic and Interventional Neuroradiology of the University Hospital of Bern, Switzerland. During the fMRI scanning session, participants completed two blocks of the Fribourg reward task, one without (control condition) and one with the experimentally-induced acute stressor (stress condition).

### **5.3.3 Fribourg reward task**

This event-related fMRI task was adapted from the spatial delayed task developed by Martin-Soelch et al. (2009) to elicit brain responses to reward anticipation and delivery. At the onset of each trial, a visual cue (1500 ms) was presented informing participants of the effort level of WM to expend (low and high) and the monetary reinforcement associated with performance (“blank screen” for non-rewarded trials or “\$\$” for rewarded trials). After the presentation of a fixation cross (500 ms), participants saw an array of yellow circles (3 or 7 circles, 1500 ms). A fixation cross (3000 ms) was presented before the visual target (1500 ms). The visual target (a green circle) was displayed at any position on the screen and signaled that the participant should decide as quickly as possible whether this circle was at the same position as one of the circles presented previously. After response execution and a variable jittered inter-stimulus-interval (ISI; 0 ms or 2000 ms), the feedback screen (1000 ms) informed the win (“blank screen” for non-rewarded trials; “1 CHF” for

rewarded trials) and was followed by a last screen (1000 ms) indicating the cumulated amount of earned money (rewarded trials) or a blank screen (non-rewarded trials). Every four trials, participants rated their mood and stress levels for a maximal duration of 20 s. Correct responses were associated with monetary gains (1 CHF) in the rewarded condition. Correct responses were not associated with monetary gains (0 CHF) in the non-rewarded condition. All functional images were acquired within two distinct blocks. In the first one (i.e. control condition), no stressor was included during the task. In the second one (i.e. stress condition), a moderate stress was introduced through the administration of six unpredictable mild electric shocks to investigate its impact on reward responsiveness. In this task, the cognitive effort to expend was modulated with two levels of WM load (low and high) corresponding to the number of circles to be remembered. In total, the task comprised 96 trials, 48 in each block. All four type of trials (reward  $\times$  load) were randomly distributed within each block. Participants were informed that they would receive the total sum in cash at the end of the scanning session. Figure 5.1 details the timing of the events of a rewarded and a non-rewarded trial.

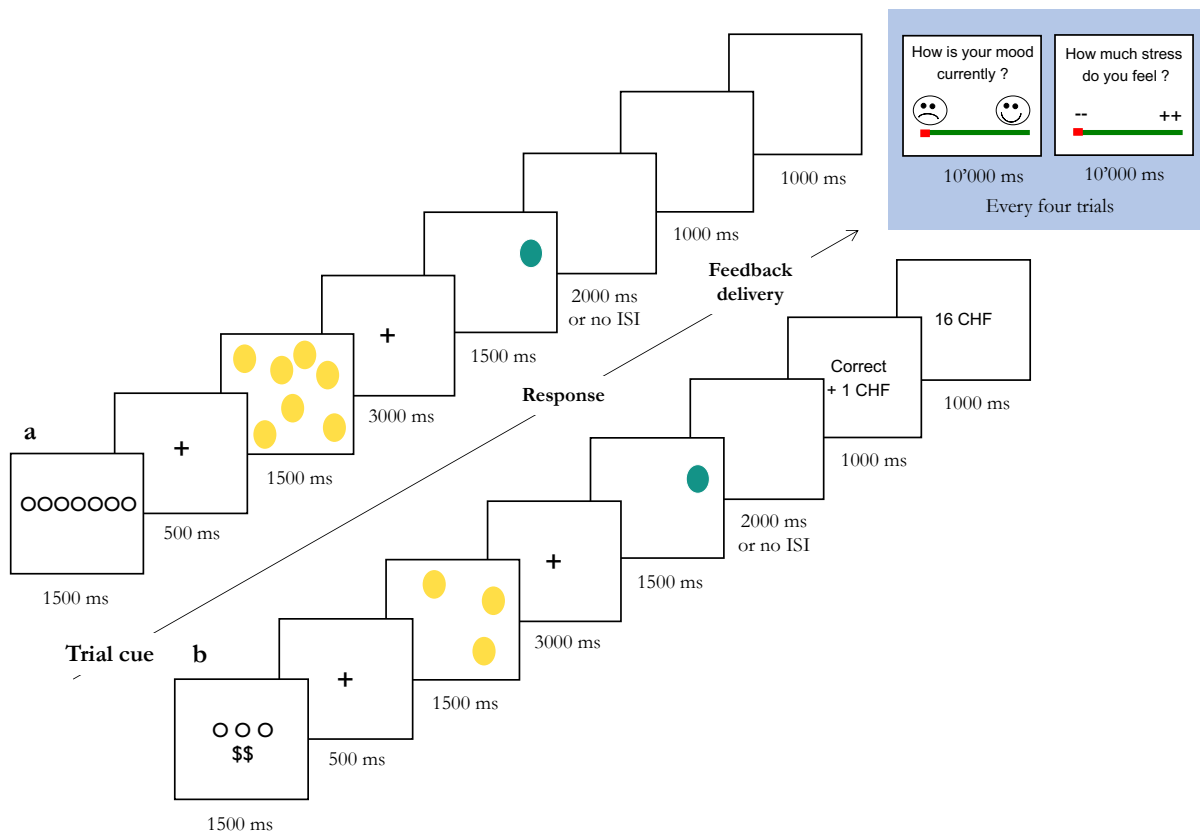

Figure 5.1. Illustration of (a) a non-rewarded trial at the highest level of working memory load and (b) a rewarded trial at the easiest working memory load of the Fribourg reward task.

### **5.3.4 Acute experimental stress manipulation**

Participants were told that they may receive electrical shocks at any time during the second block of the experimental task (stress condition). Six unpredictable mild electric shocks were delivered during the stress condition. Shocks were given on the external side of the non-dominant left hand of participants via 6-mm Ag/AgCl electrodes, using the SHK module of the Psychlab system (Contact Precision Instruments, London, UK). The electrode wires were connected to a non-ferromagnetic shock box placed on a table just beside the scanner. Before entering the scanner, a standard shock workup procedure was conducted to determine individual shock intensity ( $M = 1.07 \text{ mA} \pm 0.09$ ), starting at the lowest level and increasing the intensity until the participant identified an “aversive, but not painful” feeling (O. J. Robinson, Letkiewicz, Overstreet, Ernst, & Grillon, 2011). Highest allowable intensity level of the shock was 5 mA (milliamperes).

### **5.3.5 Self-reported ratings of the experimental stressor manipulation**

Every four trials of the event-related Fribourg reward task, self-reported ratings of mood and stress were assessed at the end of the trial using a Visual Analog Mood Scale (scaled from 0 to 9) adapted from Nyenhuis and colleagues (1997). For each participant, self-reported ratings were averaged separately during the control condition and the stress condition and were entered into SPSS (IBM SPSS Statistics, Version 25.0, Armonk, NY, USA).

### **5.3.6 MR data acquisition**

MRI acquisition was performed at the Department of Diagnostic and Interventional Neuroradiology of the University Hospital of Bern, Switzerland. The functional MRI images were acquired using a Siemens TrioTim syngo 3.0-Tesla whole-body scanner (Erlangen, Germany) equipped with a 32-channel head coil. MRI acquisition included 3D T1-weighted (MPRAGE) images with the following settings: sagittal slices: 176; FOV: 256 mm × 256 mm; matrix size: 256 × 256; voxel size: 1.0 × 1.0 × 1.0 mm<sup>3</sup>; TR: 2300 ms; TE: 2.32 ms; flip angle: 8°. During the event-related task-based fMRI, an EPI pulse sequence was used with following settings: interleaved ascending slices: 38; FOV: 192 × 192 mm; matrix size: 64 × 64; voxel size: 3.0 × 3.0 × 4.0 mm<sup>3</sup>; TR: 2000 ms; TE: 30 ms; flip angle: 90°. The event-related task-based fMRI included two blocks within one scanning session. Each block lasted on average 20 minutes. Stimuli were presented via goggles (VisualStimDigital MR-compatible video goggles; Resonance

Technology Inc., Northridge, CA, USA) with a visual angle of 60°, a resolution of 800 × 600 pixels and 60 Hz refresh rate. The task was run using E-Prime (Version 2.0.10.353, Psychology Software Tools, Inc.). Total time in the scanner was approximately 60 minutes.

### **5.3.7 Analyses of working memory performance**

A 2×2×2 repeated measures ANOVA with reward (rewarded, not-rewarded) × stress (control, stress) × load (low, high) as within-subjects factors was run using SPSS (IBM SPSS Statistics, Version 25.0, Armonk, NY, USA) on reaction times and response accuracy on the WM task.

### **5.3.8 Analyses of the acute experimental stressor effect on self-reported ratings**

The effect of acute experimental stressor manipulation on self-reported measurements of stress and mood was tested by computing the difference between self-reported ratings during the control condition and the stress condition. A Wilcoxon signed ranks test was applied using SPSS (IBM SPSS Statistics, Version 25.0, Armonk, NY, USA). A non-parametric test was used because mood rating scores were not normally distributed and due to two outliers among the stress rating scores.

### **5.3.9 fMRI data analysis**

#### **5.3.9.1 fMRI data preprocessing**

All images were processed using the AFNI software package (Cox, 1996). Subjects with gross motion exceeding 3 mm were excluded from further analysis (averaged motion:  $0.05 \pm 0.01$ ). The EPI images were preprocessed according to the following steps using *afni\_proc.py*. Motion parameters from each block were used as separate regressors and did not differ significantly between the control condition (mean of volume censored: 0.45 %) and the stress condition (mean of volume censored: 0.47%),  $t_{(22)} = -.09, p > 0.05$ . To correct for motion, any EPI volume with an Euclidean mean of 0.3 mm shift from its preceding volume was censored from regression along with its preceding volume. Subject-level exclusion for motion was based on the 0.3 mm censoring. In addition, volumes with more than 10% of (motion-based) voxel outliers were censored. Subjects with more than 10% censored volumes were excluded from analysis. Three subjects were excluded based on these criteria, leaving a sample of  $n = 23$ . T1 images were first processed with FreeSurfer

version 6.0.0 (Fischl et al., 2004) to obtain segmentation masks corresponding to the skull-stripped brain, white-matter, and ventricles. Whole-brain masks were warped with standard normalization to MNI space using the ICBM 2009a Nonlinear Symmetric atlas (Fonov et al., 2009), and spatially smoothed with an isotropic 6 mm full-width half maximum Gaussian kernel. Binary masks were averaged and thresholded at 0.75 (i.e. 75% overlap) to create a group-level grey matter mask (Torrioni et al., 2015).

### 5.3.9.2 fMRI data analysis

Statistical analysis was performed within the framework of the GLM, as implemented in the AFNI program *3dDeconvolve*. Analyses focused on changes in BOLD contrast that occurred during reward anticipation and feedback delivery. To determine the effects of monetary reward, experimental stressor and WM load on BOLD responses, a GLM was performed with stress (control vs stress), reward (rewarded vs not-rewarded), and load (high vs low load) as fixed factors, and subjects as a random factor. To test *a priori* hypotheses focusing on the interaction effect between stress and WM load on striatal sensitivity to reward during reward anticipation and feedback delivery, three ROI were created using the maximum probability atlas of Desai DKD maps in FreeSurfer (Desikan et al., 2006; Destrieux et al., 2010; Fischl, 2004). ROI included the bilateral NAcc, caudate nucleus, and putamen. Next,  $2 \times 2 \times 2$  repeated measures ANOVA with reward (rewarded, not-rewarded)  $\times$  stress (control, stress)  $\times$  load (low, high) as within-subjects factors was calculated for testing our hypotheses on striatal ROI. To address the concerns of inflated false positive rates identified by Eklund et al. (2016), whole-brain activation maps were corrected for multiple comparisons by using a cluster-based approach by conducting 10'000 Monte Carlo simulations using the AFNI program *3dClustSim*. The updated *3dClustSim* version includes a mixed ACF that better models non-Gaussian noise structure (Cox et al., 2017). fMRI data were then thresholded using a voxelwise p-value threshold of  $p < 0.001$ , and a minimum cluster size of  $k = 18$ , which corresponds to a whole-brain, cluster-level alpha of  $p < 0.05$ . ROI activation analyses were corrected for multiple comparisons by applying a Bonferroni correction ( $p\text{-value} = p\text{-value} / 3 = 0.02$ ). For each subject and condition, the parameter estimates (beta weights) were extracted from ROI contrast maps by averaging the activation of all voxels located in the ROI. Parameter estimates from each ROI were normally distributed and satisfied the homogeneity of variance assumption. Next, parameter estimates from each ROI were entered into SPSS.

## 5.4 RESULTS

### 5.4.1 Effect of acute experimental stressor on self-reported ratings

We first assessed whether self-reported stress and negative mood ratings increased in the stress condition. A Wilcoxon signed ranks test showed a significant increase in self-reported stress in the stress condition ( $Mdn = 2.0$ ;  $IR = 2.2$ ) compared to the control condition ( $Mdn = 1.7$ ;  $IR = 2.4$ ),  $Z = -2.35$ ,  $p \leq 0.02$ . In addition, a significant decrease in the subjective mood ratings was induced by the stress condition ( $Mdn = 7.2$ ;  $IR = 3.4$ ) compared to the control condition ( $Mdn = 7.8$ ;  $IR = 3.8$ ),  $Z = -2.05$ ,  $p \leq 0.04$  (see Figure 5.2).

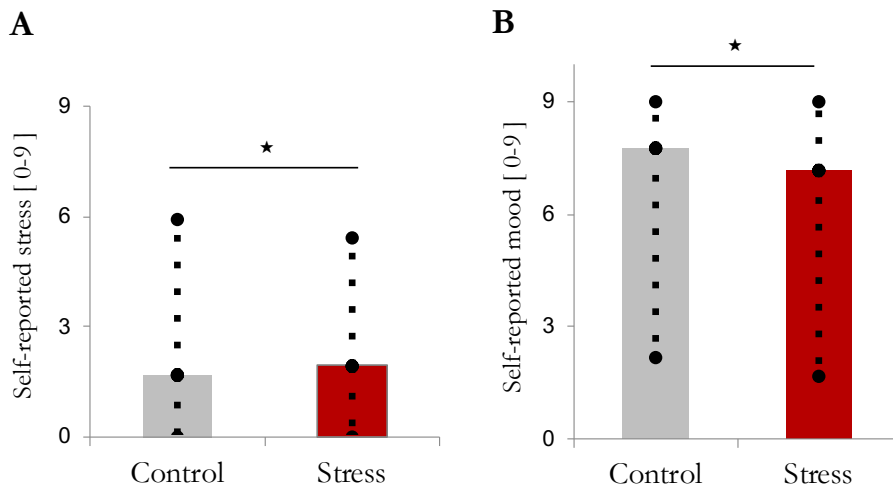

Figure 5.2. Effect of the stress condition on subjective mood and stress ratings during the Fribourg reward task. (A) Median and min./max. scores characterizing self-reported stress in the control and stress conditions, scaled from 0 'not stressed at all' to 9 'very stressed'. (B) Median and min./max. scores characterizing self-reported mood in the control and stress conditions, scaled from 0 'very negative mood' to 9 'very positive mood'. \* $p < .05$ , \*\* $p < .01$ , \*\*\* $p < .001$ .

## 5.4.2 Working memory performance

### 5.4.2.1 Response accuracy

As predicted, the repeated measures ANOVA on the response accuracy revealed a main effect of reward with significant increased response accuracy in rewarded trials ( $M = 83.1\%$ ;  $SE = 1.4\%$ ) compared to not-rewarded trials ( $M = 79.2\%$ ;  $SE = 2.2\%$ ),  $F_{(1,22)} = 9.2$ ,  $p < 0.01$ ,  $\eta^2 = 0.29$ . In accordance with our expectation, a main effect of WM load showed a significant decreased response accuracy in trials under high WM load ( $M = 74.3\%$ ;  $SE = 2.1\%$ ) compared to low WM load ( $M = 88.0\%$ ;  $SE = 1.8\%$ ),  $F_{(1,22)} = 55.0$ ,  $p < 0.001$ ,  $\eta^2 = 0.71$ . Unexpectedly, a main effect of stress appeared with increased response accuracy in the stress condition ( $M = 84.7\%$ ;  $SE = 1.8\%$ ) compared to the control condition ( $M = 77.7\%$ ;  $SE = 2.1\%$ ),  $F_{(1,22)} = 13.4$ ,  $p < .0001$ ,  $\eta^2 = 0.38$ .

### 5.4.2.2 Reaction times (RT)

Corroborating our expectation, the repeated measures ANOVA on RT showed a significant main effect of WM load indicating slower RT in trials under high load ( $M = 825.0$  ms;  $SE = 18.1$  ms) compared to low load ( $M = 742.1$  ms;  $SE = 19.0$  ms),  $F_{(1,22)} = 75.1$ ,  $p < 0.001$ ,  $\eta^2 = 0.77$ . The stress condition led to significant faster RT ( $M = 754.1$  ms;  $SE = 21.4$  ms) compared to RT in the control condition ( $M = 813.0$  ms;  $SE = 17.0$  ms),  $F_{(1,22)} = 16.9$ ,  $p < 0.001$ ,  $\eta^2 = 0.43$ . The effect of reinforcement did not significantly affect RT (see Figure 5.3).

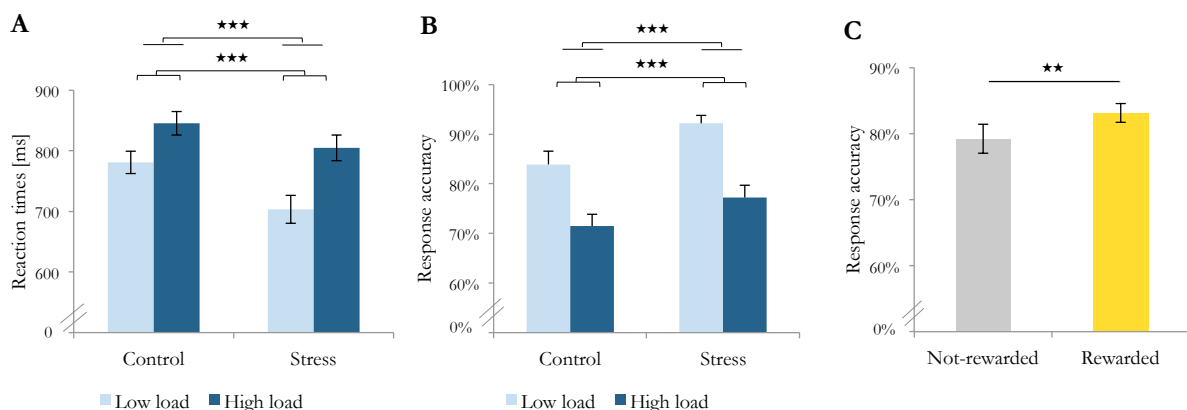

Figure 5.3. Working memory performance during the Fribourg reward task. (A) Averaged response accuracy in the control vs stress conditions according to low and high WM load. (B) Averaged reaction times in the control vs stress conditions according to low and high WM load. (C) Averaged response accuracy in rewarded and not-rewarded trials.  $*p < .05$ ,  $**p < .01$ ,  $***p < .001$ .



### 5.4.3 fMRI results

#### 5.4.3.1 Striatal activations during reward anticipation

The anticipation of potential monetary rewards induced a significant main effect of reward with increased activation in the NAcc ( $F_{(1,22)} = 9.60$ ,  $p < 0.01$ ,  $\eta^2 = 0.30$ , Bonferroni-corrected), caudate nucleus ( $F_{(1,22)} = 12.51$ ,  $p < 0.002$ ,  $\eta^2 = 0.36$ , Bonferroni-corrected) and putamen ( $F_{(1,22)} = 9.11$ ,  $p < 0.01$ ,  $\eta^2 = 0.29$ , Bonferroni-corrected) in rewarded trials compared to non-rewarded trials. Both threat-of-shock and level of WM load did not show any significant effect on the neural correlates of reward anticipation (see Figure 5.4 and Table 5.1).

#### ANTICIPATION

Significant main effect of reward in the (A) nucleus accumbens, (B) caudate nucleus, and (C) putamen.

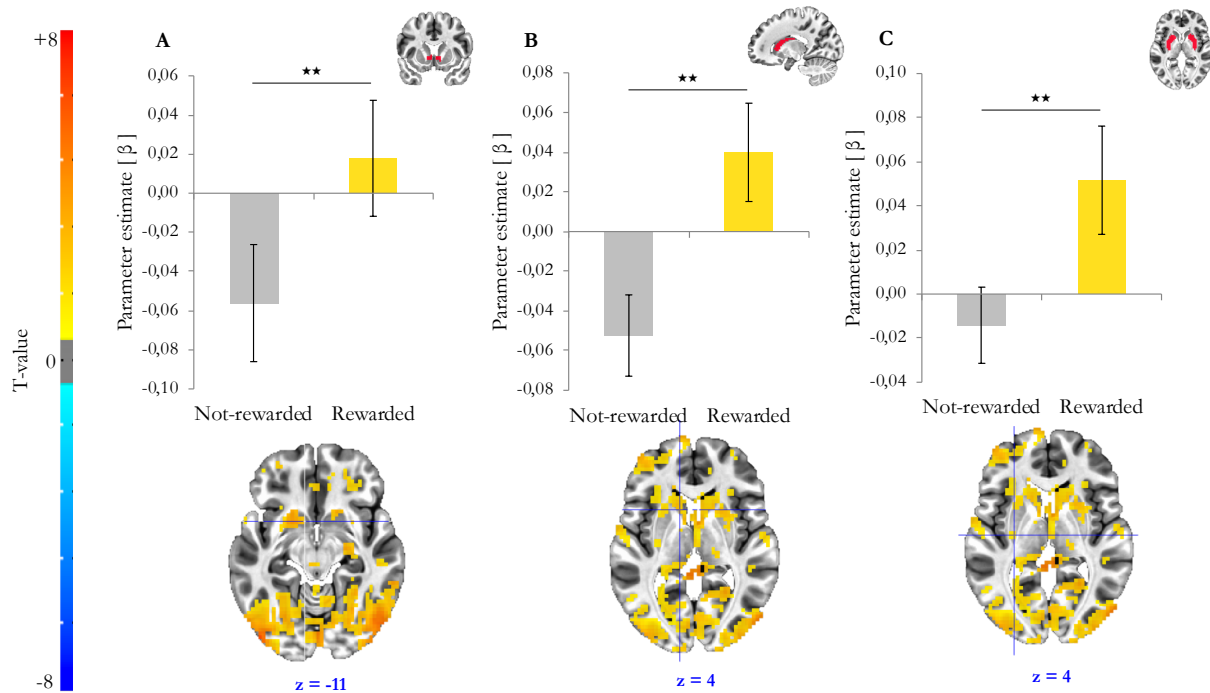

Figure 5.4. Illustration of the main effect of reward during the anticipation phase. Significant main effect of reward (rewarded vs not-rewarded) in the bilateral (A) nucleus accumbens, (B) caudate nucleus, (C) putamen. Parameter estimates ( $\beta$  weights) mean with standard errors are presented at the top of the figure. Statistical parametric maps corresponding to the contrasts of interest during anticipation are presented below. These whole-brain activations are corrected for multiple comparisons, but thresholded here at 0.05 for visualization purpose.  $*p < .05$ ,  $**p < .01$ ,  $***p < .001$ .

At a  $p < 0.001$  level (Bonferroni-uncorrected), a main effect of cognitive load appeared in the putamen with significantly increased activation under high load relative to low load ( $F_{(1,22)} = 4.44, p < 0.05, \eta^2 = 0.17$ , Bonferroni-uncorrected). In addition, a significant interaction between reward and stress was obtained in the putamen ( $F_{(1,22)} = 5.03, p < 0.05, \eta^2 = 0.19$ , Bonferroni-uncorrected) with a post-hoc analysis revealing significantly higher parameter estimates in rewarded vs not-rewarded trials in the stress condition ( $t_{(22)} = 3.38, p < 0.001$ , Bonferroni-uncorrected), whereas this difference was not significant anymore in the control condition ( $t_{(22)} = 1.27, p > 0.05$ , Bonferroni-uncorrected). Similarly, a significant  $2 \times 2 \times 2$  interaction emerged among reward, stress, and WM load in the putamen ( $F_{(1,22)} = 4.47, p < 0.05, \eta^2 = 0.17$ , Bonferroni-uncorrected). Post-hoc analyses indicated that, under high cognitive load, activation in response to monetary reward was significantly increased in both the control ( $t_{(22)} = 2.18, p < 0.05$ , Bonferroni-uncorrected) and the stress condition ( $t_{(22)} = 2.54, p < 0.05$ , Bonferroni-uncorrected). In contrast, under low cognitive load, activation in response to monetary reward was significantly increased only in the stress condition (stress condition:  $t_{(22)} = 3.25, p < 0.001$ , Bonferroni-uncorrected; control condition:  $t_{(22)} = -0.34, p > 0.05$ , Bonferroni-uncorrected).

Table 5.1

Main and interaction effects of within-subject contrasts in the bilateral nucleus accumbens (NAcc), caudate nucleus, and putamen.

Within-subjects contrasts	Stress	Reward	WM load	Anticipation									Delivery								
				NAcc			Caudate nucleus			Putamen			NAcc			Caudate nucleus			Putamen		
				$F_{(1,22)}$	$p$	$\eta^2$	$F_{(1,22)}$	$p$	$\eta^2$	$F_{(1,22)}$	$p$	$\eta^2$	$F_{(1,22)}$	$p$	$\eta^2$	$F_{(1,22)}$	$p$	$\eta^2$	$F_{(1,22)}$	$p$	$\eta^2$
Stress	Stress vs Control			0.33	0.57	0.02	0.27	0.61	0.01	0.22	0.64	0.01	0.75	0.40	0.03	<b>6.81</b>	<b>0.016</b>	<b>0.24</b>	6.08	0.02	0.22
Reward		R vs NR		<b>9.60</b>	<b>0.01</b>	<b>0.30</b>	<b>12.51</b>	<b>0.00</b>	<b>0.36</b>	<b>9.11</b>	<b>0.01</b>	<b>0.29</b>	0.05	0.83	0.00	1.17	0.29	0.05	0.02	0.88	0.88
Load			High vs Low	0.37	0.55	0.02	3.13	0.09	0.13	4.44	0.05	0.17	6.35	0.02	0.33	6.20	0.02	0.22	0.83	0.37	0.37
Stress × Reward	Stress vs Control	R vs NR		0.00	0.95	0.00	0.27	0.61	0.01	5.03	0.04	0.19	0.30	0.59	0.01	0.04	0.85	0.00	0.17	0.69	0.69
Stress × Load	Stress vs Control		High vs Low	0.72	0.41	0.03	0.04	0.85	0.00	0.09	0.76	0.00	0.00	0.99	0.00	1.22	0.28	0.05	1.04	0.32	0.32
Reward × Load		R vs NR	High vs Low	1.05	0.32	0.05	0.03	0.87	0.00	0.46	0.50	0.02	<b>7.76</b>	<b>0.01</b>	<b>0.26</b>	5.10	0.03	0.19	2.34	0.14	0.14
Stress × Reward × Load	Stress vs Control	R vs NR	High vs Low	0.00	0.99	0.00	0.90	0.36	0.04	4.47	0.05	0.17	0.15	0.70	0.01	0.40	0.53	0.02	0.17	0.68	0.69

Note. Analyses of region-of-interest activations were corrected for multiple comparisons by applying a Bonferroni correction ( $p$ -value  $< p$ -value / 3  $< 0.02$ );  $F$ , F-statistic with degrees of freedom for effect and error;  $\eta^2$ , partial eta squared, NR, not-rewarded; R, rewarded; WM, working memory. Partial eta squared ( $\eta^2$ ) represents the proportion of total variance accounted for by the factor, while excluding other factors from the total explained variance (i.e. nonerror variation) in the repeated measures ANOVA (Pierce, Block, & Aguinis, 2004). Partial eta squared ( $\eta^2$ ) values range from 0 to 1.

### 5.4.3.2 Striatal activations during feedback delivery

During feedback delivery, a main effect of stress was present in the caudate nucleus with higher activation in the stress condition compared to the control condition ( $F_{(1,22)} = 6.81, p < 0.05, \eta^2 = 0.24$ , Bonferroni-corrected). Additionally, a significant reward by WM load interaction occurred in the NAcc ( $F_{(1,22)} = 7.76, p < 0.05, \eta^2 = 0.26$ , Bonferroni-corrected). Post-hoc analysis indicated that the NAcc responses to reward delivery depended on the level of WM load, with greater responsiveness to reward delivery in low WM load compared to high WM load ( $T_{(22)} = 3.85, p < 0.001$ , Bonferroni-corrected) (see Figure 5.5). Significant whole-brain clusters ( $p < 0.05$ , cluster-wise corrected) are presented in Table 5.2 (see Table A.1 and Table A.2 in Appendix for a comprehensive report of whole-brain analysis in all conditions).

#### DELIVERY

Significant (A) main effect of stress in the caudate nucleus and (B) interaction effect (reward  $\times$  WM load) in the nucleus accumbens

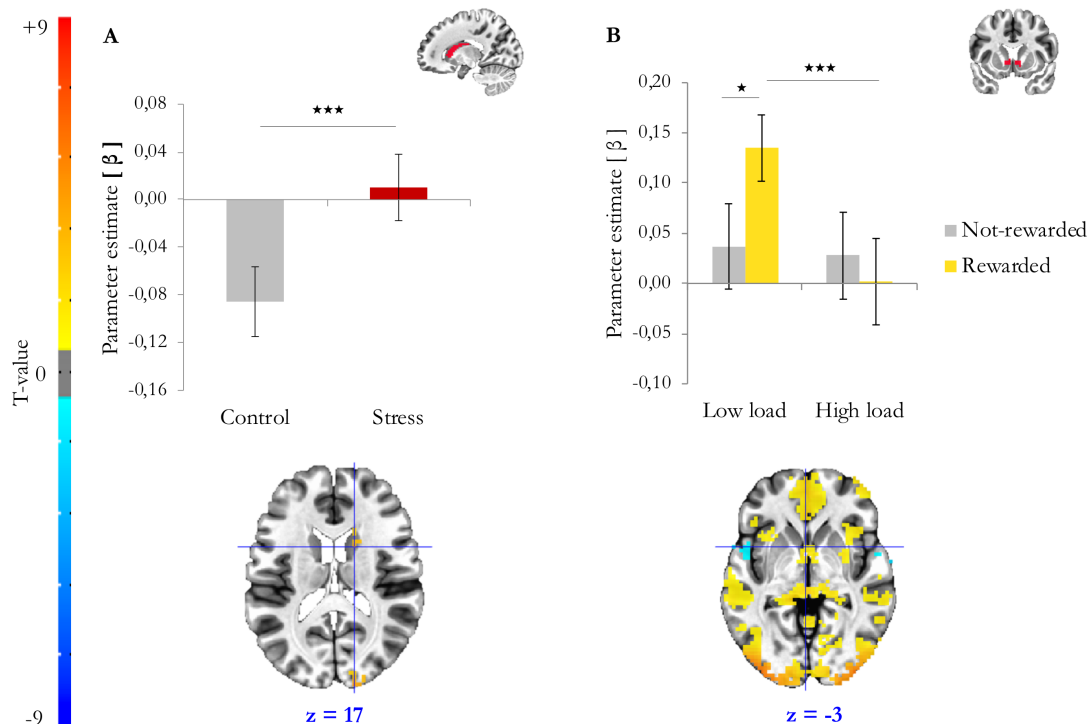

*Figure 5.5.* Illustration of the main effect of stress and the twofold interaction effect (reward  $\times$  load) during the delivery phase. (A) Significant main effect of stress (stress condition vs control condition) in the bilateral caudate nucleus showing increased activation in the stress condition compared to the control condition. (B) Significant reward by working memory (WM) load interaction in the nucleus accumbens, showing decreased responsiveness to reward delivery under high compared to low WM load. Parameter estimates (beta weights) mean with standard errors are presented at the top of the figure. Statistical parametric maps corresponding to the contrasts of interest during anticipation are presented below. These whole-brain activations are corrected for multiple comparisons, but thresholded here at 0.05 for visualization purpose. \* $p < .05$ , \*\* $p < .01$ , \*\*\* $p < .001$ .

At a  $p < 0.001$  level (Bonferroni-uncorrected), a main effect of stress occurred in the putamen, with higher activation in the stress condition compared to the control condition ( $F_{(1,22)} = 6.08, p < 0.05$ , Bonferroni-corrected). Additionally, a main effect of WM load appeared in the NAcc ( $F_{(1,22)} = 6.35, p < 0.05$ , Bonferroni-uncorrected) and the caudate nucleus ( $F_{(1,22)} = 6.20, p < 0.05$ , Bonferroni-uncorrected), with significant increased activation under low load relative to high load. A significant reward by load interaction emerged in the caudate nucleus ( $F_{(1,22)} = 5.10, p \leq 0.034$ , Bonferroni-uncorrected). Post-hoc analysis showed significantly higher parameter estimates in low vs high cognitive load in the rewarded trials ( $t_{(22)} = 3.85, p < 0.001$ , Bonferroni-uncorrected), whereas this difference was not significant in not-rewarded trials ( $t_{(22)} = 0.46, p > 0.05$ , Bonferroni-uncorrected).

Table 5.2

*Significant whole-brain clusters (cluster-size corrected) for (1) the main effect of reward (rewarded vs not-rewarded) during the anticipation phase, and (2) the main effect of stress (stress vs control), as well as interaction effect between reward (rewarded vs not-rewarded) and working memory (WM) load (high vs low) during the delivery phase*

Activated clusters in brain regions	Side	MNI coordinates (LPI)			Cluster size	T-Value
		x	y	z		
<b>1. ANTICIPATION PHASE</b>						
Main effect of reward: rewarded > not-rewarded trials						
Lateral occipital	L	-47	-86	-11	456	4.32
Fusiform	R	50	-65	-20	297	5.56
Superior parietal	L	-8	-80	53	70	4.03
Lateral occipital	R	38	-92	14	61	4.11
Superior parietal	R	29	-59	68	34	4.13
Supramarginal	L	-53	-38	56	31	4.45
Superior parietal	R	32	-41	50	30	4.63
Rostral middle frontal	L	-41	50	2	27	4.60
Superior parietal	L	-20	-83	41	27	4.75
Lingual	R	8	-83	-17	25	3.84
Cerebral white matter	L	-20	-71	8	24	4.89
Superior parietal	R	23	-83	50	21	5.68
<b>2. DELIVERY PHASE</b>						
Main effect of stress : stress > control conditions						
Superior parietal	R	20	-92	38	42	5.11
Superior frontal	L	-2	11	38	31	4.69
Lateral occipital	R	17	-101	20	28	4.72
Insula	L	-38	-23	5	22	5.00
PCC	R	11	-26	41	20	5.11
Caudate	R	17	8	17	18	3.97
Postcentral	L	-56	-26	47	18	3.99
Interaction effect Reward × WM load: rewarded > not-rewarded trials in the low load condition						
Lateral occipital	L	-47	-86	-11	1867	4.95
Superior frontal	L	-2	62	2	247	4.36
Superior parietal	L	-32	-65	56	126	3.98
PCC	R	2	-29	32	78	4.80
Superior temporal	L	-62	-35	5	74	8.13
Inferior parietal	R	44	-59	59	47	3.88
Precentral	L	-47	5	38	41	4.00
Superior parietal	R	44	-47	56	41	4.38
Insula	R	32	14	-20	26	4.08
Superior frontal	L	-2	38	23	26	4.18
Cerebellum	L	-29	-74	-47	24	4.46

*Note.* Whole-brain activations presented for every specific contrasts are corrected for multiple comparisons using a cluster-based approach with a voxelwise  $p$ -value threshold of  $p < 0.001$  and a minimum cluster size of  $k = 18$ , which corresponds to a cluster-level alpha of  $p < 0.05$ . L, left ; R, right ; LPI means that x increases from Left to Right, y increases from Posterior to Anterior, z increases from Inferior to Superior.

## 5.5 DISCUSSION

The aim of our first empirical work was to investigate the effects of an acute stressor induced experimentally by threat-of-shock and of cognitive effort (high vs low WM load) on the striatal responsiveness to monetary reward, during reward anticipation and feedback delivery. To the best of our knowledge, this is the first study specifically exploring how stress induction and WM load modulate neural reactivity to reward during anticipatory and delivery phases. Consistent with prior fMRI studies, stress manipulation successfully induced negative affect and increased self-reported stress in participants (Bogdan & Pizzagalli, 2006; Grillon et al., 1993). Contrary to our expectations, no significant interaction occurred among stress, cognitive load and reward during the anticipation of potential monetary reward. Enhanced striatal reactivity to potential reward occurred in rewarded trials, irrespective of the modulation by the experimental stressor or by the cognitive effort to expend for getting the reward. Crucially, both stress and cognitive effort affected striatal activation during feedback delivery, but these factors did not interact to modulate reward responsiveness. First, striatal reactivity to reward delivery was modulated by the level of WM effort that was expended to obtain the reward, with significantly decreased responsiveness to monetary reward in the ventral striatum following high, compared to low, cognitive effort. Second, stress strengthened reactivity in the dorsal striatum during feedback delivery and enhanced cognitive performance.

This first empirical work indicates that both ventral and dorsal striatum responded to potential monetary reward during the cue-triggered anticipation irrespective of the presence of an experimental stressor or of the level of cognitive effort engaged for obtaining the reward. These findings converge with previous data demonstrating increased activation in striatal regions in response to anticipated monetary reward (Knutson & Greer, 2008; E. M. Miller, Shankar, Knutson, & McClure, 2014; Rademacher et al., 2014). In this first empirical work, a significant increase in striatal responsiveness to anticipated reward was additionally consistent with enhanced behavioral performance in rewarded trials, compared to non-rewarded trials. Collectively, our results showed that potential reward improved response accuracy. These behavioral results are in accordance with findings pointing out that reward was able to increase cognitive performance (J. M. Choi et al., 2015; Savine et al., 2010), as evidenced, for instance, in a spatial WM task (Kennerley & Wallis, 2009). Increased striatal responsiveness to anticipated reward and improved behavioral performance might reveal enhanced reward-driven motivation. In contrast to our hypotheses, no effect of the experimental stressor together with the level of cognitive load modulated the neural reactivity to reward. These findings are in contradiction with recent studies suggesting that stress (Kumar et al., 2014) and greater cognitive demands (Vassena et al., 2014) led to higher involvement of the neural circuits underlying motivated behaviors.

During feedback delivery, the striatal responsiveness to reward delivery was modulated by the level of cognitive effort deployed for obtaining the reward. In particular, our results indicated decreased reward responsiveness in the ventral striatum following high, compared to low, cognitive effort. So far, little evidence exists on the relationship between task difficulty and reward processes. During challenging cognitive tasks, a recent study demonstrated higher ventral striatal activation in response to rewarding feedback when the cognitive effort was more demanding to participants (Satterthwaite et al., 2012). In contrast to these results, our data suggest that performance and hedonic processes engaged in demanding tasks are altered by the level of cognitive effort, resulting in lower behavioral performance and decreased reward valuation under higher WM load. Interestingly, the acute experimental stressor strengthened activation in the caudate nucleus during feedback delivery, irrespective of the level of cognitive effort or of the presence of incentive. Increased threat-related recruitment of the caudate nucleus might be due to heightened arousal mediated by increased DA release in the striatum, as previously suggested in the case of the NAcc (Cabib & Puglisi-Allegra, 2012; Pruessner, Champagne, Meaney, & Dagher, 2004; Soares et al., 2013). In humans, enhanced DA signalling in the striatum has been linked with the arousing effect of novel or alerting cues (Horvitz, 2002; Soares-Cunha, Coimbra, Sousa, & Rodrigues, 2016) and with the attentional capture by salient cues (for a review see: Anderson et al., 2016). Since our study did not manipulate DA pharmacologically, interpretations on the potential involvement of the DA system should be considered with caution. Together with the caudate nucleus, the superior frontal regions, the superior parietal lobule, and the anterior insula also showed increased threat-related activation. This finding is in line with a recent study evidencing enhanced recruitment of the caudate nucleus, the anterior insula and regions of the frontoparietal attention network under threat-of-shock (Torrizi et al., 2016). Although not predicted, increased threat-related activation in these regions was paralleled by improved cognitive performance under threat-of-shock. Indeed, stress elicited higher response accuracy and faster reaction times. This is in accordance with behavioral findings in animals (Yuen et al., 2011) and humans (Duncko, Johnson, Merikangas, & Grillon, 2009), showing threat-related enhanced WM performance (Duncko et al., 2009).

This first empirical work comes with some limitations deserving mention. First, given our within-subjects design and that both blocks with and without stressor took place on the same day, no randomization was possible between blocks, in order to avoid the potential bleeding of negative effects induced by threat-of-shock into the control condition. However, this methodology permits to avoid the methodological issues of scanning in different days. Second, although stress manipulation induced negative affect and strengthened self-reported stress, no physiological data



are supporting the effectiveness of the stress manipulation. A final limitation is that the sample size was relatively small, and, thus, the results should be considered preliminary, in need of replication.

In conclusion, our first empirical work provides initial evidence that both acute stressor and cognitive load modulate neural responsiveness during feedback delivery but not during the anticipation of potential monetary reward. Crucially, our results indicate that reward value decreases under demanding cognitive load. High cognitive effort might represent a cost, which decreases the value of the reward, and shifts attention away from the reward. In addition, threat-of-shock facilitates behavioral performance, probably by increasing arousal and attentional focus through the recruitment of striatal regions and areas involved in the frontoparietal attention network (Balderston, Hale, et al., 2017; McEwen & Sapolsky, 1995; Torrisi et al., 2016). In sum, these findings extend previous work on reward processing and open new avenues for understanding how stress and cognitive effort are intertwined and how they modulate motivational and hedonic processes. In particular, they open important questions for future studies about the contexts where threat and attentional demands might alter or improve reward responsiveness. Ultimately, this first empirical work may help to build a framework to understand common stress-related disorders, given that depression and other psychiatric conditions involve disturbances of the reward system, cognitive deficits and abnormal stress reactivity.

## **5.6 ACKNOWLEDGEMENTS**

We are very thankful to the University of Fribourg for funding this research, the MRI technicians at the Department of Diagnostic and Interventional Neuroradiology at the University Hospital of Bern, Switzerland, and all the participants who took part in this study and made it possible. Additionally, special thanks to Richard Reynolds and Nicholas Balderston.

## **5.7 FUNDING**

This work was supported by the Research Pool of the University of Fribourg, Fribourg, Switzerland [n°578].

## **5.8 DECLARATION OF INTEREST**

We certify that none of the authors has a financial interest to report. This work received no external grant, but was internally funded by the Research Pool of the University of Fribourg, Fribourg, Switzerland.

# CHAPTER 6

## EMPIRICAL WORK II

---

### NUCLEUS ACCUMBENS REACTIVITY TO REWARD DELIVERY IS NEGATIVELY ASSOCIATED WITH MALADAPTIVE EMOTION REGULATION AND DEPRESSIVE SYMPTOMS

Claudie Gaillard<sup>1</sup>, Matthias Guillod<sup>1</sup>, Monique Ernst<sup>2</sup>, Salvatore Torrisi<sup>2</sup>, Andrea Federspiel<sup>3</sup>, Dominik Schoebi<sup>4</sup>, Romina E. Recabarren<sup>1</sup>, Xinyi Ouyang<sup>5</sup>, Christoph Mueller-Pfeiffer<sup>6</sup>, Antje Horsch<sup>7,8</sup>, Philipp Homan<sup>9</sup>, Roland Wiest<sup>10</sup>, Gregor Hasler<sup>11</sup>, Chantal Martin-Soelch<sup>1</sup>

<sup>1</sup> IReach Lab, Unit of Clinical and Health Psychology, Department of Psychology, University of Fribourg, Fribourg, Switzerland.

<sup>2</sup> Section on Neurobiology of Fear and Anxiety, National Institutes of Mental Health, Bethesda, USA.

<sup>3</sup> Psychiatric Neuroimaging Unit, Translational Research Center, University Hospital of Psychiatry, University of Bern, Bern, Switzerland.

<sup>4</sup> Unit of Clinical Family Psychology, Department of Psychology, University of Fribourg, Fribourg, Switzerland.

<sup>5</sup> iBM Lab, Department of Psychology, University of Fribourg, Fribourg, Switzerland.

<sup>6</sup> Department of Consultation-Liaison-Psychiatry and Psychosomatic Medicine, University Hospital Zurich, University of Zurich, Zurich, Switzerland.

<sup>7</sup> Department Woman-Mother-Child, Lausanne University Hospital, Lausanne, Switzerland.

<sup>8</sup> Institute of Higher Education and Research in Healthcare, University of Lausanne, Lausanne, Switzerland.

<sup>9</sup> Center for Psychiatric Neuroscience, Feinstein Institute for Medical Research, New York, USA.

<sup>10</sup> Department of Diagnostic and Interventional Neuroradiology, University Hospital of Bern, Bern, Switzerland.

<sup>11</sup> Unit of Psychiatry Research, University of Fribourg, Fribourg, Switzerland.

# EMPIRICAL WORK II

---

## 6.1 ABSTRACT

**Background :** in daily life, positive emotions are essential for well-being and are intrinsically related to the hedonic pleasure one feels when getting a reward. However, the mechanisms linking emotional to reward processes remain poorly understood. A reduced experience of positive emotions has been related to the propensity to use preferentially maladaptive emotion regulation strategies (Aldao & Nolen-Hoeksema, 2010; Frank et al., 2014). Emotion regulation is therefore emerging as a promising candidate at the interplay between emotional processes and optimal reward function. The first aim of this empirical work was to explore how adaptive and maladaptive emotion regulation strategies are associated with the neural responsiveness to the delivery of monetary rewards in healthy adults, with a particular focus on the nucleus accumbens (NAcc). Since disrupted reward responsiveness together with dysfunctional emotion regulation are core symptoms of major depression disorder (MDD), a second aim was to investigate how the NAcc reactivity to reward delivery and emotion regulation are related to subclinical depressive symptoms in healthy adults.

**Methods :** we measured neural activation in the NAcc in response to the delivery of monetary reward through functional magnetic resonance imaging (fMRI) in a sample of 23 healthy adults aged 20-37 (mean age:  $24.7 \pm 0.9$ ), of which 14 females. Cognitive emotion regulation strategies and current depressive symptoms were evaluated using self-reported questionnaires. We performed correlations to explore how individual's NAcc reactivity to reward delivery was related to the propensity to use adaptive and maladaptive emotion regulation strategies, and to current subclinical depressive symptoms.

**Results :** NAcc activation in response to reward delivery was negatively and significantly correlated with the use of maladaptive emotion regulation strategies. Additionally, participants with higher depressive symptoms showed significantly reduced NAcc responsiveness to reward delivery.

**Conclusions :** this empirical work suggests that maladaptive emotion regulation is linked to decreased reward responsiveness, which might increase the risk for MDD. These findings provide insights for understanding the complex relationship linking emotion regulation to the reward function and might open new avenues for prevention and treatment targets.

**Keywords:** reward responsiveness, emotion regulation, depressive symptoms, nucleus accumbens, fMRI.

## 6.2 INTRODUCTION

The capacity to experience pleasure and to engage in motivated behaviors for its pursuit is determinant for human survival and reproduction (Haber & Knutson, 2010; Kringelbach, 2005). A stimulus is rewarding because of its ability to elicit positive emotions ('liking' component) which, in turn, have the power to initiate motivated behaviors to act for it ('wanting' component) (Richards et al., 2013). In other words, positive emotions are determinant for promoting approach behaviors toward advantageous resources, whereas negative emotions contribute to prevent damaging and harmful consequences by engaging avoidance behaviors (Knutson & Greer, 2008). The experience of pleasure is characterized by the hedonic and positive emotions following the delivery or consumption of pleasurable outcomes (K. C. Berridge et al., 2009). Reward processing might therefore constitute a special case of emotion processing and a way to assess the processing of positive emotions (Kringelbach, 2005). In this framework, a recent study evidenced the essential role played by the reward system in emotional experience, showing that positive emotions in daily life were predicted by the reward responsiveness as reflected by increased reactivity of the ventral striatum in response to positive hedonic stimuli in an experimental fMRI task (Heller et al., 2015). In line with these findings, a robust reward system was shown to promote the maintenance of positive affects among individuals confronted to adversity in everyday life (Nikolova & Hariri, 2012). Although a growing body of literature has demonstrated the close relationship between reward and emotional processes, the specific factors linking reward to emotion processing remain still poorly understood.

Recently, the role of the corticostriatal pathway was evidenced in the experience and maintenance of positive emotions, in particular the relationship linking stronger connectivity between the ventral striatum and the mPFC at rest to sustained positive emotions over time (Admon & Pizzagalli, 2015a). Therefore, adaptive emotion regulation emerges as a promising candidate linking positive emotions to reward processing (Delgado, Li, Schiller, & Phelps, 2008). Emotion regulation constitutes the fundamental capacity to influence, consciously or not, one's emotional experience (Gross & Jazaieri, 2014; Naragon-Gainey, McMahon, & Chacko, 2017). Successful emotion regulation might be attained by up-regulating positive emotions over negative emotions or by down-regulating negative emotions (Frank et al., 2014; Ochsner et al., 2004). Specifically, the ventral striatum was directly implicated in the up-regulation of positive emotions in healthy adults (Kim & Hamann, 2007; Morawetz, Bode, Baudewig, et al., 2017), suggesting that the reward function might be essential for strengthening and maintaining positive emotions. Characterized by blunted reward responsiveness and the tendency to use maladaptive emotion regulation strategies (for a review see: Joormann & Stanton, 2016), major depression is one of the

most prevalent and burdensome mental disorder (for a review see: Zhang et al., 2013). Thus, the convergence between disrupted reward processes and maladaptive emotion regulation strategies might constitute crucial risk factors for the onset of MDD in healthy individuals (Hasler et al., 2004; Zhang et al., 2013).

In line with these findings, the first aim of this second empirical work was to examine how adaptive and maladaptive emotion regulation strategies are linked to the neural responsiveness to the delivery of monetary rewards in healthy adults, with a particular focus on the NAcc located in the ventral striatum. The second aim was to investigate how the NAcc reactivity to reward delivery, as well as adaptive and maladaptive emotion regulation strategies are associated with subclinical depressive symptoms in healthy adults. First, we hypothesized that the propensity of healthy adults to use (i) adaptive emotion regulation strategies would correlate with stronger NAcc responsiveness to reward delivery, whereas (ii) maladaptive emotion regulation strategies would be linked to reduced NAcc responsivity to reward delivery. Second, we expected that the intensity and severity of subclinical depressive symptoms in healthy adults would correlate negatively with both (iii) stronger NAcc responsiveness to reward delivery, and (iv) increased tendency to use adaptive emotion regulation strategies. In contrast, we postulated that subclinical depressive symptoms in healthy adults would be positively associated with (v) heightened propensity to use of maladaptive emotion regulation strategies.

## 6.3 MATERIALS AND METHODS

### 6.3.1 Participants

A total of 23 healthy participants were included in this second empirical work (14 females, mean age:  $24.7 \pm 0.9$ , aged 20-37 years), positioned in the middle class relative to the Swiss population. Subjects' demographic characteristics are summarized in Table 6.1. Before entering the study, participants were screened for potential psychiatric disorders using the structured M.I.N.I. (Sheehan et al., 1998). The presence of a past or current major depressive disorder was assessed additionally using the MADRS (Montgomery & Asberg, 1979; French version: Pellet, Bobon, Mormont, Lang, & Massardier, 1980). The MADRS scale includes 10 items coded from 0 to 6, with a total score ranging from 0 to 60. A score of 15 or above indicates the presence of a major depressive episode (Bouvard & Cottraux, 2010). Exclusion criteria included the presence of any history of neurological or endocrine diseases, presence of any current or past mental disorders, the use of any psychoactive drugs and general contra-indications related to fMRI measures.

Table 6.1

*Socio-demographic and psychological description of the sample (N = 23, 14 females), parameter estimate's mean of the neural activation in the nucleus accumbens characterizing reward responsiveness to reward delivery, and normality test of the variables (Kolmogorov-Smirnov)*

	<i>M</i>	<i>SD</i>	<i>SE</i>	<i>Mdn</i>	<i>IR</i>	<i>Min.</i>	<i>Max.</i>	Kolmogorov-Smirnov		
								<i>df</i>	<i>Statistics</i>	<i>p-value</i>
Age	24.7	4.3	0.9	23	5	20	37	22	0.20	.02
IPSE	57.9	16	3.4	62	23	15	84	22	0.14	.20
MADRS	3.6	4.0	0.9	3	5	0	14	22	0.23	.003
BDI-II mean scores	4.8	4.9	1.0	4	6	0	19	22	0.19	.04
CERQ mean scores										
Adaptive ER	14.4	2.7	0.6	14.2	4.5	9.4	19.2	22	0.14	.20
Maladaptive ER	8.5	2.0	0.4	8.5	3.9	5.3	11.5	22	0.17	.12
NAcc PE	0.1	0.1	0.03	0.1	0.2	-0.1	0.5	22	0.20	.20

*Note.* BDI-II, Beck Depressive Inventory II ; CERQ, Cognitive Emotion Regulation Questionnaire ; *df*, degree of freedom ; IPSE, Index of Economic Status Position according to the Swiss Population; *IR*, interquartile range ; *M*, mean ; MADRS, Montgomery and Asberg Depression Rating Scale ; *Max.*, maximal score ; *Mdn*, median ; *Min.*, minimal score ; *SE*, standard error ; NAcc, nucleus accumbens ; PE, parameter estimates.



### **6.3.2 General procedure**

All recruitment and testing procedures were approved by the local ethical review board (CER-VD). This second empirical work comprised an experimental task with fMRI measurements followed by the completion of self-reported questionnaires. The fMRI session was performed at the Department of Diagnostic and Interventional Neuroradiology of the University Hospital of Bern, Switzerland.

### **6.3.3 Self-reported psychological measurements**

#### **6.3.3.1 Beck Depressive Inventory II (BDI-II)**

To assess the intensity and severity of depressive symptoms experienced over the two weeks preceding the measurements, we used the BDI-II (Beck et al., 1996, French version: 1998). This standardized and widely used scale comprises 21 items rated on a 4-point Likert-like scale ranging from 0 to 3. The total score for all 21 items ranges from 0 to 63, with higher scores indicating higher intensity and severity of depressive symptoms. Cut-off scores for the French version were established as guidance with total scores ranging from 0 to 11 indicating the absence of major depressive episode, from 12 to 19 a mild depressive episode, from 20 to 27 moderate depressive episode and above 27 a severe depressive episode (Bouvard & Cottraux, 2010). Although the mean score ( $M = 4.8$ ;  $SE = 1.0$ ) on the BDI-II was clearly below the cutoff characterizing a clinical symptomatology, total scores of participants in this study scaled from 0 to 19. Specifically, 20 participants reported no depressive episode (scores ranging from 0 to 11) while two participants presented symptoms characterizing a mild depressive episode (scores ranging from 12 to 20). This suggests an important variance among the sample with some participants experiencing marked depressive symptoms, although it did not satisfy the criteria for MDD. Psychometric properties have been widely demonstrated in the general population and clinical samples with high reliability and internal consistency (Wang & Gorenstein, 2013), as seen in young healthy adults (Cronbach's  $\alpha = .89$ ) (Whisman et al., 2000). A reliability analysis was carried out on the BDI-II in our sample including 23 healthy participants and indicated a high internal consistency (Cronbach's  $\alpha = .86$ ).

### 6.3.3.2 Cognitive Emotion Regulation Questionnaire (CERQ)

We used the CERQ (Garnefski & Kraaij, 2007; French version: Jermann et al., 2006) to evaluate the use of cognitive emotion strategies with 36 items rated on a 5-point Likert response format (from 1 ‘almost never’ to 5 ‘almost always’). This multidimensional scale assesses nine emotion regulation strategies which can be divided into adaptive and maladaptive emotion regulation strategies providing a score for each type of strategy. A score is calculated for each of the nine cognitive emotion regulation strategies by summing up the scores on the 4 items constituting the subscale, with the total score on each cognitive emotion regulation strategy ranging from 4 to 20. The global score indicating the tendency to use adaptive or maladaptive emotion regulation strategies are computed by calculating the average score of the subscales included in both types of emotion regulation strategy, with global scores on both adaptive and maladaptive emotion regulation strategies ranging from 4 to 20. The French version showed a good factorial validity and internal reliabilities of the nine subscales with Cronbach’s  $\alpha$  ranging from .68 to .87 (Jermann et al., 2006). Adaptive strategies including acceptance, positive refocusing, refocusing on planning, positive reappraisal, and putting into perspective showed Cronbach’s  $\alpha$  of 0.89, while maladaptive strategies encompassing self-blame, rumination, catastrophizing, and blaming others showed Cronbach’s  $\alpha$  of 0.82 (Jermann et al., 2006). This empirical work focuses on the two global dimensions reflecting (i) adaptive and (ii) maladaptive emotion regulation strategies. In our sample of 23 healthy adults, the internal consistency of these dimensions assessing adaptive (Cronbach’s  $\alpha = .89$ ) and maladaptive (Cronbach’s  $\alpha = .79$ ) emotion regulation strategies was high.

### 6.3.4 Fribourg reward task

This event-related fMRI task was adapted from the reward task developed by Martin-Soelch et al. (2009). This task was designed to assess how the neural reactivity to reward is modulated by the level of cognitive effort to expend (low vs high spatial WM load). At the onset of each trial, a visual cue (1500 ms) was presented to inform the participants of the level of WM load (3 circles for low ; 7 circles for high) and of the amount of monetary reward (“blank screen” for non-rewarded ; “\$\$\$” for rewarded) associated with correct answers. The stimulus (1500 ms) consisted in an array of yellow circles (3 or 7 circles). A fixation cross (3000 ms) was displayed during the memorization delay preceding the presentation of the visual target. The visual target (one green circle, 1500 ms) appeared at any position on the screen. The participants were asked to decide as quickly and accurately as possible whether the visual target was located at the same position as one of the yellow circles presented previously. After the subject responded or after time elapsed, a

variable jittered inter-stimulus-interval (ISI; 0 ms or 2000 ms) preceded the feedback screen (1000 ms). The feedback screen informed the participants of the win (“blank screen” for non-rewarded trials or incorrect response in rewarded trials ; “1 CHF” for correct answer in rewarded trials). In rewarded trials, a last screen indicated the total amount of earned money (1000 ms). A blank screen (1000 ms) was presented when the trial was non-rewarded or when the response was incorrect. Every four trials, participants were asked to rate their levels of stress (“0” for ‘not-stressed’ at all to “9” for ‘very stressed’) and mood (“0” for ‘very negative mood’ to “9” for ‘very positive mood’) for a maximal duration of 20 seconds. Some trials were rewarded (1 CHF), others not (0 CHF). In the rewarded trials, a monetary gain (1 CHF) was delivered for each correct response, while incorrect responses were non-rewarded. In the non-reward condition, no reward was delivered for correct answers. All functional images were acquired over one scanning session within two distinct blocks of approximately 20 minutes. In the first one (i.e. control condition), no stressor was included during the task. In the second one (i.e. stress condition), a mild stressor was induced through the administration of six unpredictable mild electric shocks to investigate its impact on reward responsiveness. In total, the task comprised 96 trials, 48 in each block. All four type of trials (reward  $\times$  load) were randomly distributed within each block. Before starting the scanning session, participants were trained on the task outside the scanner, and informed that, at the end of the session, they would receive in cash the total sum they earned during the task. Figure 6.1 details the timing of a trial with the illustration of a rewarded trial under low WM load (3 circles) and a non-rewarded trial under high WM load (7 circles). The task was implemented using E-Prime Professional (Version 2.0.10.353, Psychology Software Tools, Inc.). Stimuli were presented via goggles (VisualStimDigital MR-compatible video goggles; Resonance Technology Inc., Northridge, CA, USA) with a visual angle of 60°, a resolution of 800 x 600 pixels and 60Hz refresh rate.

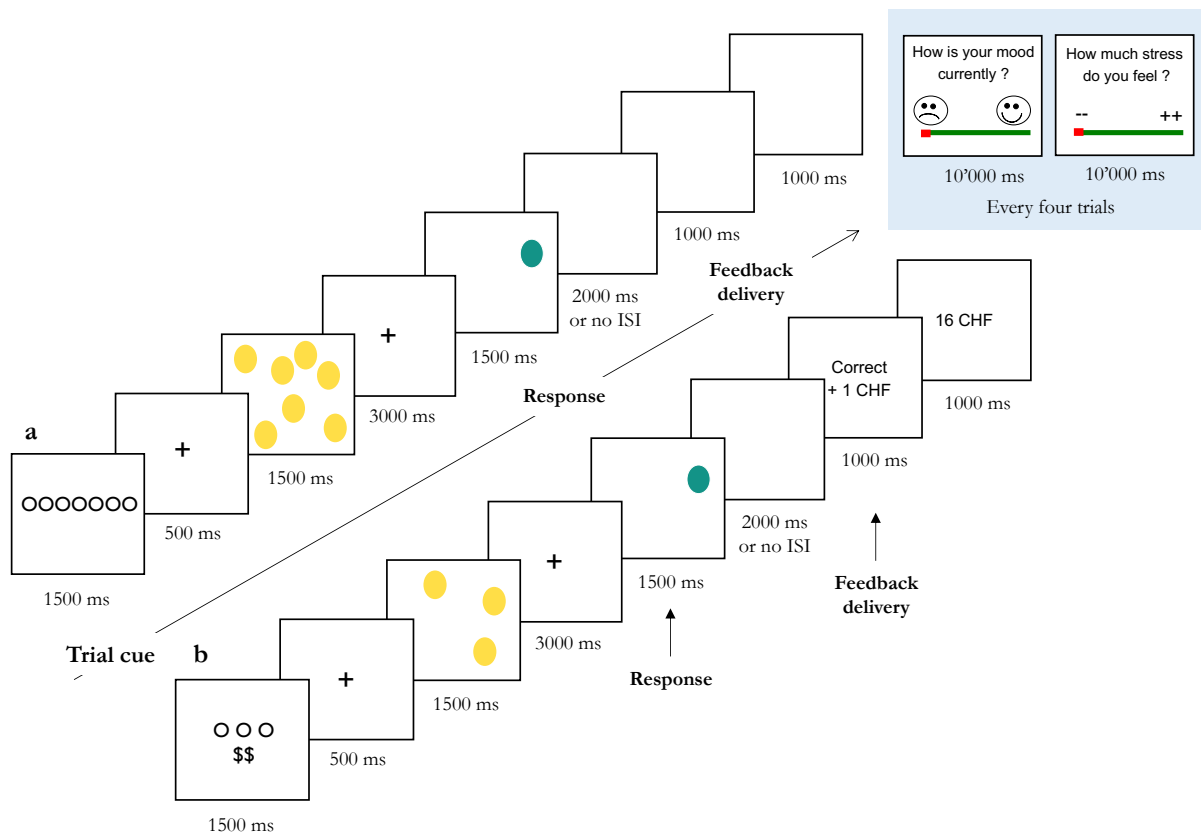

Figure 6.1. Illustration of two trials of the Fribourg reward task. (a) a not-rewarded trial under high working memory load and (b) a rewarded trial under low working memory load.

### 6.3.5 MR data acquisition

The functional MRI images were acquired using a Siemens (Erlangen, Germany) TrioTim syngo 3.0-Tesla whole-body scanner equipped with a radio frequency 32-channel head coil. MRI acquisition included 3D T1-weighted (MPRAGE) images with the following settings: sagittal slices: 176 ; slice thickness: 1.0 mm ; FOV:  $256 \times 256 \text{ mm}^2$  ; matrix size:  $256 \times 256$  ; voxel size:  $1 \times 1 \times 1 \text{ mm}^3$  ; TR: 1950 ms ; TE: 2.2 ms ; flip angle:  $90^\circ$ . The event-related task-based fMRI included EPI pulse sequence with the following settings: interleaved ascending slices: 38 ; slice thickness: 3.0 mm ; FOV:  $230 \times 230 \text{ mm}^2$  ; matrix size:  $64 \times 64$  ; voxel size:  $3.6 \times 3.6 \times 3 \text{ mm}^3$  ; TR: 2000 ms ; TE: 30 ms ; flip angle:  $90^\circ$ .

### 6.3.6 fMRI data analysis

Functional data preprocessing and statistical analyses were performed with the AFNI software package (Cox, 1996).

#### 6.3.6.1 Task-based fMRI data preprocessing

Before applying the processing AFNI pipeline, tissue segmentation was performed using FreeSurfer version 6.0.0 (Fischl, 2004). The following preprocessing steps were run to the EPI data using the *afni\_proc.py* script: despiking the time-series (*despike*), correcting for slice timing (*tshift*), volume co-registering to the participants' corresponding anatomical (MPRAGE) image (*align*), volume registration across the timeseries (*volreg*), blurring within the whole-brain mask (*blur*), normalization (*scale*), and regressors modeled (*regress*). To correct for motion (averaged motion per volume:  $0.05 \pm 0.01$ ), we censored EPI volumes and their preceding volume where the derivative of the motion regressors from *3dvolreg* had a Euclidean norm above 0.3 mm. Any volume including more than 10% voxel outliers were censored as well. Based on these criteria, we excluded three subjects with more than 10% censored volumes, over the 26 initial participants. The preprocessed EPI timeseries were then warped to MNI space using the ICBM 2009a Nonlinear Symmetric atlas (Fonov et al., 2009), and spatially smoothed using an isotropic 6 mm FWHM Gaussian filter. Finally, we created a group-level grey matter mask by averaging and thresholding binary masks at 0.75 overlap (Torrissi et al., 2015).

#### 6.3.6.2 Task-based fMRI data analysis

Statistical analysis was performed within the framework of the GLM, as implemented in the AFNI program *3dDeconvolve*. As described in more details in our first empirical work (see Chapter 5, section 5.3.9.2), we carried a GLM with stress (stress vs control), reward (rewarded vs not-rewarded) and load (high vs low) as fixed factors, and subjects as a random factor was conducted to determine the effect of (1) stress, (2) monetary reward, and (2) cognitive load on the BOLD responses. In our first empirical work, we evidenced a significant twofold interaction effect (reward  $\times$  load) in the bilateral NAcc ( $F_{(1,22)} = 7.76, p < .05, \eta^2 = 0.26$ ) during the reward delivery, irrespective of stress (see Chapter 5, section 5.4.3.2). Post hoc analysis further indicated that NAcc responsiveness to the delivery of monetary reward depended upon the level of WM load, with significantly higher activation in response to the delivery of monetary reward following low compared to high WM performance ( $t_{(22)} = 3.85, p < .001$ ). The NAcc is a brain region crucially

implicated in the encoding of the reward value and in reward learning (Hassan & Benarroch, 2015; Schultz, 2016). Reduced NAcc activation to reward was notably linked to decreased positive emotions experienced by individuals with major depression (Sharp et al., 2014), suggesting that the NAcc might constitute a vulnerability marker of abnormal positive emotional processes. Therefore, the analyses of our second empirical work examine more closely the significant changes in BOLD contrast found in the NAcc for the contrast of rewarded vs not-rewarded trials in the low WM trials, and how the NAcc responsiveness is associated to emotion regulation and subclinical depressive symptoms in healthy adults.

### **6.3.7 Correlation between reward-related NAcc activity and emotion regulation**

To test the hypothesis that the neural reactivity to the delivery of monetary reward is modulated by emotion regulation, we examined the relationship between NAcc responsiveness to reward delivery and the propensity to use both adaptive and maladaptive emotion regulation strategies. These strategies were assessed with the CERQ by computing a global score for the use of adaptive and of maladaptive emotion regulation strategies (Garnefski, Kraaij, & Spinhoven, 2001; French version: Jermann et al., 2006). Individual parameter estimates extracted in the NAcc in the low cognitive load condition during the reward delivery, and CERQ mean scores were then entered into SPSS (IBM SPSS Statistics, Version 22.0, Armonk, NY, USA). A Pearson correlation was chosen since the distributions of (i) task-based NAcc parameter estimates and CERQ mean scores including (ii) adaptive and (iii) maladaptive emotion regulation strategies were normally distributed.

### **6.3.8 Correlation between reward-related NAcc activity and depressive symptoms**

To explore the hypothesis that NAcc reactivity to the delivery of monetary reward might constitute a protective factor against the emergence of depressive symptoms, we examined the correlation between the NAcc responsiveness to reward delivery and self-reported depressive symptoms. The intensity and severity of depressive symptomatology was evaluated with the BDI-II (Beck et al., 1996, French version: 1998). As BDI-II mean scores were not normally distributed, a Spearman correlation was applied to test the correlation between task-based NAcc reactivity to reward delivery and BDI-II mean scores (see Table 6.1).

### **6.3.9 Correlation between emotion regulation and depressive symptoms**

Finally, we examined the relationship between the intensity and severity of subclinical depressive symptoms measured with the BDI-II (Beck et al., 1996, French version: 1998) and the propensity to use (i) adaptive and (ii) maladaptive emotion regulation strategies evaluated by the CERQ (Garnefski & Kraaij, 2007; French version: Jermann et al., 2006). Therefore, we computed correlation scores using Spearman coefficients to take into account that BDI-II scores were not normally distributed.

## 6.4 RESULTS

### 6.4.1 Correlation between reward-related NAcc activity and emotion regulation

We found a significant negative correlation between the NAcc reactivity to reward delivery and CERQ scores assessing the use of maladaptive emotion regulation strategies,  $r = -0.45$ ,  $p_{one-tailed} = 0.019$  (see Figure 6.2). However, CERQ scores measuring the use of adaptive emotion regulation strategies were not significantly associated with NAcc responsiveness to monetary reward during delivery,  $r = -0.11$ ,  $p_{one-tailed} = 0.31$ .

### 6.4.2 Correlation between reward-related NAcc activity and depressive symptoms

We showed a significant negative correlation between NAcc responsiveness to the delivery of monetary rewards and BDI-II scores assessing self-reported subclinical depressive symptoms,  $r_s = -0.45$ ,  $p_{one-tailed} = 0.018$  (see Figure 6.2).

### 6.4.3 Correlation between emotion regulation and depressive symptoms

We found no significant relationship between CERQ scores measuring the use of maladaptive emotion regulation strategies and BDI-II scores reporting subclinical depressive symptoms,  $r_s = 0.32$ ,  $p_{one-tailed} = 0.08$ . Moreover, no significant relationship appeared between the propensity to use adaptive emotion regulation strategies and self-reported subclinical depressive symptomatology,  $r_s = -0.15$ ,  $p_{one-tailed} = 0.26$ .



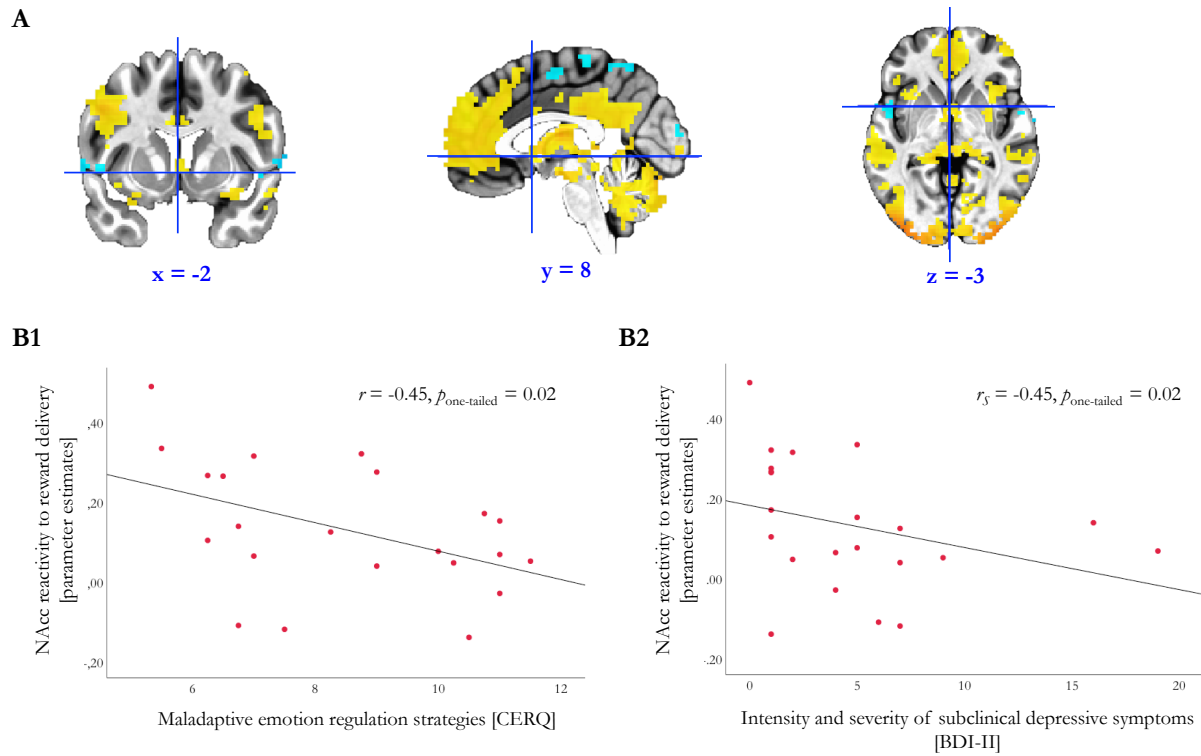

*Figure 6.2.* Illustration of the significant associations between nucleus accumbens (NAcc) responsiveness to reward delivery and both, the propensity to use maladaptive emotion regulation strategies and subclinical depressive symptoms in healthy adults. (A) Statistical parametric map illustrating clusters with bilateral NAcc activation for the contrast ‘rewarded > not-rewarded’ in the low cognitive load condition during the reward delivery. Significant relationships between NAcc responsiveness to reward delivery (individual parameter estimates) following low cognitive load and both, (B1) CERQ scores evaluating the tendency to use maladaptive emotion regulation strategies, and (B2) BDI-II scores reflecting the severity and intensity of subclinical depressive symptoms in healthy adults. The statistical parametric map is overlaid onto a canonical structural brain image Montreal Neurological Institute coordinates using the ICBM 2009a Nonlinear Symmetric atlas (Fonov et al., 2009). Results are corrected for multiple comparisons using Bonferroni correction and thresholded here at .05 for visualization purpose. BDI-II, Beck Depressive Inventory II; CERQ, Cognitive Emotion Regulation Strategies.

## 6.5 DISCUSSION

This second empirical work aimed first at investigating how adaptive and maladaptive emotion regulation strategies are associated with the striatal responsiveness to the reward delivery in healthy adults, with a particular focus on the NAcc. Second, we examined how the NAcc reactivity to reward delivery as well as adaptive and maladaptive emotion regulation strategies correlate with the severity and intensity of subclinical depressive symptoms in healthy adults. So far, little is known on the interplay between reward and emotional processes. As expected, our results showed that NAcc responsiveness to reward receipt is negatively associated with maladaptive emotion regulation strategies, suggesting that reduced NAcc responsiveness to rewards might go together with the propensity to use more maladaptive emotion regulation strategies. In line with our hypotheses, the NAcc reactivity to reward delivery correlated with the severity and intensity of the subclinical depressive symptoms reported by healthy adults. Specifically, stronger self-reported depressive symptoms were associated with reduced NAcc responsiveness to reward receipt, suggesting that decreased neural sensitivity to rewards is associated with increased vulnerability to anhedonic symptoms.

These findings are in accordance with emerging data showing the involvement of the ventral striatum in emotion regulation processes promoting the maintenance of positive emotions in healthy adults (Kim & Hamann, 2007; Morawetz, Bode, Baudewig, et al., 2017). They are also consistent with and extend previous reports that evidenced the strong implication of a disrupted reward circuitry in the symptomatology of major depression. A wealth of data demonstrated the loss of or a strong reduction in the capacity to engage oneself in motivated behaviors oriented toward positive outcomes (Hägele et al., 2015; Ubl, Kuehner, Kirsch, Rutter, Diener, et al., 2015; for a review see: Zhang et al., 2013) and to experience pleasure and positive emotions (Forbes & Dahl, 2010; Pizzagalli et al., 2009; Zhang et al., 2013) in individuals suffering from MDD. Even before their onset, depressive symptoms might therefore be predicted by impaired reward processing (W. Liu et al., 2016; Vrieze et al., 2013). By showing a relationship linking neural reactivity to reward to self-reported depressive symptoms in healthy individuals, our findings provide a support to the idea that the inability to experience hedonic feelings might constitute an important risk factor for MDD, even in healthy individuals without any particular vulnerability. Eventhough participants were healthy without any past or current mental disorders, self-reported depressive symptoms in our sample showed an important variance among them, with some participants who met the clinical threshold defining a mild depressive state. Since the vulnerability to depression is probably characterized by a large continuum among healthy individuals, ranging

from the absence of any depressive symptoms to subclinical symptoms, this extended variability in our sample is particularly interesting for studying the vulnerability to MDD.

So far, little is known about the ways reward processes and emotion regulation interact in healthy individuals and how this interaction may precipitate the onset of depressive symptoms. While our results cannot be viewed as conclusive, they raise several interesting questions and implications for future research. So far it has been assumed that negative affects, loss of motivation, and pleasure arise from disrupted corticolimbic connectivity (Davidson et al., 2002; Erk et al., 2010). In this vein, an important question to further delineate is how higher-order cognitive functions anchored in the PFC modulate the relationship between both adaptive and maladaptive emotion regulation and reward responsiveness. A second question that future research is warranted to investigate is whether the distinct motivational processes involved during reward anticipation and reward delivery show different patterns of relationship with emotion regulation strategies in non-clinical and clinical samples. Further exploration of the neurobiological correlates underlying the close relationship between the reward function and emotion processing is needed to elaborate upon current evidence, in particular for developing relevant and effective interventions preventing the onset of mental health disorders marked by negative affects and anhedonia such as the MDD.

Several limitations of this second empirical work must be acknowledged. First, caution is called for when trying to generalize results from the current study because of the small sample size. Also, future research is needed to replicate these findings in non-clinical healthy subjects and in individuals at higher risk for MDD. Second, due to the correlational nature of the data reported here, no definitive causal statements can be made concerning the relationship between the neural responsiveness to reward and psychological processes including emotion regulation strategies and depressive symptoms. Neuroimaging studies involving machine learning and Bayesian models may help to develop models clarifying predictive factors of vulnerability, and how they might interact with other biomarkers. Third, anhedonia was assessed experimentally through the decreased neural reactivity to reward delivery. Although neural activation in response to reward provides a reliable measure of hedonic responsiveness, it is important to mention that several relevant self-reported scales exist to assess the subjective feeling of pleasure, such as the Snaith-Hamilton Pleasure Scale (Snaith et al., 1995), the Fawcett-Clark Pleasure Capacity Scale (Fawcett, 1983), and the Revised Chapman Physical Anhedonia Scale (Chapman, Chapman, & Raulin, 1976). Further studies are also needed to evaluate whether self-reported anhedonic symptoms as assessed by these scales would confirm our results.

Consistent with previous research that investigated separately the role of reward responsiveness on the one hand, and emotion regulation in increased vulnerability to MDD on the

other, our findings help to elaborate upon the mechanisms that might underlie the development of anhedonic symptoms. Taken together, they indicate that ineffective emotion regulation strategies might impair the processing of positive emotions, specifically the responsiveness to hedonic stimuli. Additionally, these results suggest that impaired emotion regulation might be a crucial factor implicated in the development or maintenance of abnormal reward processing, resulting further in the development of anhedonic symptoms. In other words, the interaction between reduced reward responsiveness and the tendency to privilege more maladaptive strategies to regulate emotional experiences might precipitate anhedonic symptoms.

## **6.6 ACKNOWLEDGEMENTS**

We are very grateful to the University of Fribourg for enabling this research, to the MRI technicians at the Department of Diagnostic and Interventional Neuroradiology at the University Hospital of Bern, Switzerland, and to all the participants for making this study possible.

## **6.7 FUNDING**

This work was internally funded by the Research Pool of the University of Fribourg, Fribourg, Switzerland [n°578].

## **6.8 DECLARATION OF INTEREST**

We certify that none of the authors has a financial interest to report.

# CHAPTER 7

## EMPIRICAL WORK III

---

### **STRIATAL REACTIVITY TO REWARD UNDER THREAT-OF-SHOCK AND WORKING MEMORY LOAD IN ADULTS AT INCREASED FAMILIAL RISK FOR MAJOR DEPRESSION**

Claudie Gaillard<sup>1</sup>, Matthias Guillod<sup>1</sup>, Monique Ernst<sup>2</sup>, Salvatore Torrisi<sup>2</sup>, Andrea Federspiel<sup>3</sup>, Dominik Schoebi<sup>4</sup>, Romina E. Recabarren<sup>1</sup>, Xinyi Ouyang<sup>5</sup>, Christoph Mueller-Pfeiffer<sup>6</sup>, Antje Horsch<sup>7,8</sup>, Philipp Homan<sup>9</sup>, Roland Wiest<sup>10</sup>, Gregor Hasler<sup>11</sup>, Chantal Martin-Soelch<sup>1</sup>

<sup>1</sup> IReach Lab, Unit of Clinical and Health Psychology, Department of Psychology, University of Fribourg, Fribourg, Switzerland.

<sup>2</sup> Section on Neurobiology of Fear and Anxiety, National Institutes of Mental Health, Bethesda, USA.

<sup>3</sup> Psychiatric Neuroimaging Unit, Translational Research Center, University Hospital of Psychiatry, University of Bern, Bern, Switzerland.

<sup>4</sup> Unit of Clinical Family Psychology, Department of Psychology, University of Fribourg, Fribourg, Switzerland.

<sup>5</sup> iBM Lab, Department of Psychology, University of Fribourg, Fribourg, Switzerland.

<sup>6</sup> Department of Consultation-Liaison-Psychiatry and Psychosomatic Medicine, University Hospital Zurich, University of Zurich, Zurich, Switzerland.

<sup>7</sup> Department Woman-Mother-Child, Lausanne University Hospital, Lausanne, Switzerland.

<sup>8</sup> Institute of Higher Education and Research in Healthcare, University of Lausanne, Lausanne, Switzerland.

<sup>9</sup> Center for Psychiatric Neuroscience, Feinstein Institute for Medical Research, New York, USA.

<sup>10</sup> Department of Diagnostic and Interventional Neuroradiology, University Hospital of Bern, Bern, Switzerland.

<sup>11</sup> Unit of Psychiatry Research, University of Fribourg, Fribourg, Switzerland.

# EMPIRICAL WORK III

---

## 7.1 ABSTRACT

**Introduction:** anhedonia is a core symptom of the Major Depression Disorder (MDD), associated with decreased reward responsiveness, especially in the striatum. Exposure to stressful life events is a major precipitant of MDD and is linked to anhedonic symptoms. Nevertheless, the mechanisms linking reward and stress to MDD in humans remain poorly understood. Reduced cognitive resources, reflected by impaired executive functions, are potential candidate factors that might modulate the effect of stress exposure on reward processing, and hence precipitate anhedonic symptoms. Here, we aimed at exploring whether the effects of stress exposure on the reward processing might differentiate between healthy vulnerable (HV) adults at increased familial risk for MDD and healthy controls (HC). In an exploratory way, we examined whether cognitive effort might modulate differently the effect of stress exposure on reward processing in HC compared to HV. We expected that stress exposure would decrease striatal reactivity to reward cues and reward delivery in HV, while stress would strengthen striatal reactivity to reward cues and reduce striatal responsiveness to reward delivery in HC, but less severely than in HV.

**Methods:** 16 HV (12 females) and 16 gender- and age-matched HC underwent a fMRI reward task with two levels of reinforcement (not-rewarded, rewarded) and two levels of working memory (WM) load (low, high) during a stress condition (induction of unpredictable threat-of-shock) and a control condition.

**Results:** during the anticipation phase, HV showed a reduced activation in the caudate nucleus in all conditions, and stress-related reduced reactivity in the nucleus accumbens, but only in the low WM load condition. During the delivery phase, the exertion of high WM effort diminished consecutively the nucleus accumbens activation in HV, irrespective of stress exposure and reinforcement schedule.

**Conclusion:** our results indicate that HV might be at increased risk to develop anhedonic symptoms due to an increased difficulty to encode reward value, in particular in stressful contexts, and to learn from rewards specifically following higher cognitive effort. These findings open new avenues for a better understanding of the complex interaction between systems at the interplay of stress and reward responsivity in the vulnerability to MDD, and how cognitive resources might modulate this interaction.

**Keywords:** vulnerability, major depression disorder, reward, stress, cognitive load, striatum, fMRI.

## 7.2 INTRODUCTION

MDD is a prevalent mental disorder affecting worldwide more than 4.4% of the population according to the last estimation of the World Health Organization in 2015 (World Health Organization, 2017). According to the Diagnostic and Statistical Manual of Mental Disorders, Fifth Edition (American Psychiatric Association, 2013), long-lasting depressed mood and anhedonia are core symptoms of MDD. At the neural level, anhedonia is underpinned by a dysfunction of the reward circuitry, which is thought to constitute a major biological marker of MDD as well as a predisposition for increased vulnerability to MDD (Hasler et al., 2004; Martin-Soelch et al., 2009). The presence of anhedonic symptoms has been robustly associated with a dysregulation during the reward processing in healthy adults (Chung & Barch, 2015; Harvey, Pruessner, Czechowska, & Lepage, 2007), in MDD patients (Epstein et al., 2006; Pizzagalli et al., 2009), and in unaffected offspring of MDD patients (W. Liu et al., 2016). Among MDD patients, a wealth of data provided strong evidence for impaired reward processes during both the anticipation of a pleasurable event (Hägele et al., 2015; for a review see: Zhang et al., 2013) and the delivery or consumption of hedonic outcomes (Forbes & Dahl, 2010; Olino et al., 2014; Pizzagalli et al., 2009; for a review see: Zhang et al., 2013). With the aim of understanding how blunted reward responsiveness during motivational and hedonic processes might characterize a familial predisposition for major depression, recent studies explored the reward processes in first-degree relatives of MDD patients. Convergent with the hypothesis of a familial predisposition, offspring of depressed patients showed blunted striatal reactivity to reward during both the anticipation of potential rewards (Olino et al., 2014) and the delivery of pleasant outcomes (Olino et al., 2014; Sharp et al., 2014) compared to healthy controls.

Extensive research has demonstrated that stressful life events were intimately linked to depressive vulnerability, to the onset of the first depressive episode (Hammen, 2005; Kendler & Gardner, 2016), as well as to relapse and recurrence of MDD (Beshai et al., 2011; for a review see: Buckman et al., 2018). According to diathesis-stress models, depressive symptoms might result from an interaction between premorbid risk factors, such as an abnormal reward function, and the exposure to stressors, with 20% to 50% risk of developing a first depressive episode in individuals confronted to a recent significant life stressor (Ingram & Luxton, 2005; Monroe & Simons, 1991). Therefore, a disrupted reward system combined with increased stress response toward life adversity might play a critical role in the emergence of MDD. Specifically, some findings evidenced the relationship linking stress exposure (e.g. threat-of-shock, negative performance feedback, or stressful life events) to both diminished responsiveness to rewards (Berenbaum & Connelly, 1993; Bogdan & Pizzagalli, 2006; Pizzagalli et al., 2007) and to negative affects (Bogdan & Pizzagalli,



2006). This is in accordance with a recent study suggesting that the relationship between reduced ventral striatal reactivity to rewards and anhedonic symptoms is modulated by the adversity encountered by the individual during childhood (Corral-Frías et al., 2015). However, studies linking stress-related anhedonia to MDD and to vulnerability to MDD remain scarce.

Cognitive deficits constitute a determinant vulnerability factor tightly linked to the etiology and pathophysiology of MDD (Beevers, 2005; Clark & Beck, 2010). A promising hypothesis linking abnormal cognitive processes to MDD suggests that a reduction in cognitive resources, or impaired inhibitory control over negative information, might give rise to negative cognitive biases underpinning subsequent depressive symptoms (Everaert et al., 2015, 2017). Specifically, the ability to allocate attention toward relevant material or to shift flexibly the attentional focus away from irrelevant information involves the WM, a higher-order cognitive function often impaired in MDD (e.g. Gohier et al., 2009; Rose & Ebmeier, 2006). Since higher-order cognitive processes such as WM are crucial to successfully and flexibly adapt to environmental demands (Diamond, 2013), an important question to further explore is how variable levels of cognitive effort modulates the effect of stress exposure on the reward responsiveness in individuals with increased vulnerability to MDD.

Taken together, previous research evidenced a blunted reward responsiveness during the anticipation and delivery phases in both MDD patients (Epstein et al., 2006; Pizzagalli et al., 2009) and in individuals vulnerable to MDD (W. Liu et al., 2016). Analogous to reduced reward responsiveness, stressful life events are critical risk factors for the occurrence of a first depressive episode (Kendler & Gardner, 2016; for a review see: R. T. Liu & Alloy, 2010), for the maintenance of depressive symptoms, and for precipitating relapse (Beshai et al., 2011; for a review see: Buckman et al., 2018). Nevertheless, few data exist on how stress exposure affects reward processing in individuals vulnerable to MDD, and how cognitive effort modulates the effect of stress exposure on the reward function. To fill this gap, here we explored whether the effect of stress exposure affects differentially the striatal reactivity to rewards in HV compared to HC during the anticipation and delivery phases. Additionally, we examined, in an exploratory way, whether the cognitive effort modulates differentially the effect of stress exposure on the striatal reactivity to rewards in HV compared to HC during both phases. Based on recent findings, we hypothesized that in HC, (i) stress exposure would strengthen striatal reactivity to cued rewards during the anticipation phase, and would reduce striatal responsiveness to reward delivery. In contrast, we expected that in HV, (ii) stress exposure would decrease striatal reactivity during both the reward anticipation and the reward delivery. At the behavioral level, we assumed that (iii) reward cues would improve WM performance by increasing response accuracy and by speeding up reaction

times, with higher enhancing effect of reward cues in HC compared to HV. Also, we expected that (iv) stress exposure would counteract the enhancing effect of reward cues on WM performance by reducing response accuracy and slowing down reaction times, with stronger impact of stress exposure in HV.

## 7.3 METHODS AND MATERIAL

### 7.3.1 Participants

Thirty-two healthy and right-handed participants aged 20-36 years ( $M = 24.2$ ;  $SE = .68$ ) were recruited from the local community through advertisements, and from psychology courses at the University of Fribourg. Among the participants, 16 healthy adults (12 women) presented increased familial vulnerability to MDD (healthy vulnerable, HV), characterized by having a biological parent with a history of MDD. Sixteen healthy controls (12 women) without increased familial vulnerability to MDD were age- and gender-matched (healthy control, HC). As reported in Table 7.1, groups did not significantly differ on age, gender, socio-demographic status, and depressive symptomatology. Parental MDD was evaluated with the family history method with the participant as an informant (Andreasen, Endicott, Spitzer, & Winokur, 1977) using the FIGS (Maxwell, 1992). Eleven HV reported having a mother, 3 HV a father, and 1 HV both parents with a history of MDD. Fifteen out of the 16 HV cohabitated with their parents at the time of parental MDD history, with length of cohabitation ranging from 1 to 19 years. Any HC who reported a first-degree relative with a history of any psychiatric disorders was excluded. Presence and history of mental disorders among participants was tested using the M.I.N.I. (Sheehan et al., 1998). All participants presented no past or current neurological, psychiatric, or hormonal conditions. Additionally, depressive symptoms among participants were assessed using the MADRS (Montgomery & Asberg, 1979; French version: Pellet et al., 1980) and the BDI-II (Beck et al., 1996, French version: 1998). The MADRS scale includes 10 items coded from 0 to 6, with a total score ranging from 0 to 60. A score of 15 or above indicates the presence of a major depressive episode (Bouvard & Cottraux, 2010). A score The BDI-II is a standardized and widely used scale to evaluate the intensity and severity of depressive symptoms over the two weeks preceding the measurements. Depressive symptoms are reported using 21 items rated on a 4-point Likert-like scale ranging from 0 to 3. The total score for all 21 items ranges from 0 to 63. As guidance, thresholds for the French version specify that total scores ranging from 0 to 11 correspond to the absence of major depressive episode, from 12 to 19 to a mild depressive episode, from 20 to 27 to a moderate depressive episode, and above 27 to a severe depressive episode (Bouvard & Cottraux, 2010). In our sample, 2 HC and 3 HV reported BDI-II scores between 12 and 19 indicating a mild depressive episode. This might suggest increased risk for MDD in participants of both groups, irrespective of the increased familial vulnerability to MDD. Psychometric properties have been widely validated with high reliability and internal consistency in clinical samples and in the general population (Wang & Gorenstein, 2013), as reported in a study including healthy young adults (Cronbach's  $\alpha = .89$ )

(Whisman et al., 2000). In our sample including 32 participants, the internal consistency was high with Cronbach's  $\alpha$  equal to .91.

Table 7.1

*Group demographics and psychological measures of depressive symptoms*

	HC (4 males, 12 females)				HV (4 males, 12 females)					Group difference				
	<i>N</i>	<i>M</i>	<i>SE</i>	<i>SD</i>	<i>N</i>	<i>Range</i>	<i>M</i>	<i>SE</i>	<i>SD</i>	<i>df</i>	<i>T-value</i>	<i>p-value</i>	<i>Mann-Whitney U</i>	<i>p-value</i>
Age	16	24.1	0.9	3.7	16	-	24.3	1.0	4.1	30	-0.18	0.86	119.5	0.75
IPSE	16	57.1	4.0	15.9	16	-	58.2	4.3	17.1	30	-0.19	0.85	102.0	0.33
Age at parental MDD onset	-	-	-	-	-	0 to 25	11.8	2.4	8.3	-	-	-	-	-
Cohabitation with a depressed parent	-	-	-	-	15	-	-	-	-	-	-	-	-	-
Length (years) of cohabitation with a depressed parent	-	-	-	-	-	1 to 19	7.6	1.9	6.5	-	-	-	-	-
MADRS mean scores	16	4.3	1.1	4.4	16	-	3.8	0.7	2.8	30	0.39	0.70	121.5	0.81
BDI-II mean scores	16	5.1	1.4	5.4	16	-	6.8	1.7	6.8	30	-0.74	0.46	107.5	0.43
Shock intensity level	16	102.8	9.9	39.5	16	-	99.6	6.1	24.4	30	0.28	0.79	-	-

*Note.* Healthy control (HC) adults without increased familial risk for major depression disorder (MDD); healthy adults with increased familial risk for MDD (HV, healthy vulnerable); *N*, number; *M*, mean; *SD*, standard deviation; *SE*, standard error; *df*, degree of freedom; *T-value*, Test of Student; IPSE, Index of Economic Status Position according to the Swiss population; BDI-II, Beck Depression Inventory II; MADRS, Montgomery and Asberg Depression Rating Scale; MDD, Major Depression Disorder.

### 7.3.2 General procedure

All recruitment and testing procedures were approved by the local ethical review board (CER-VD). This third empirical work comprised an experimental task with fMRI measurements followed by the completion of self-reported questionnaires. The fMRI session was performed at the Department of Diagnostic and Interventional Neuroradiology of the University Hospital of Bern, Switzerland. During scanning, participants completed two blocks of the same experimental task, one without and one with administration of experimental stress.

### 7.3.3 Fribourg reward task

Adapted from the reward task developed by Martin-Soelch et al. (2009), this event-related fMRI task was used to assess how the neural reactivity to monetary reward is modulated by stress exposure (unpredictable threat-of-shock) and by variable levels of WM load (low and high) during the anticipation and delivery phases. Each of the 96 trials, 48 in each block, started by a visual cue (1500 ms) to inform the subjects of the level of cognitive effort to exert and the amount of monetary reward associated with the performance (“blank screen” for not-rewarded trials ; “\$\$” for rewarded trials). A fixation cross (500 ms) preceded the presentation of an array of yellow circles (3 or 7 circles, 1500 ms). A second fixation cross (3000 ms) was displayed during memorization, followed by the visual target (1500 ms). The visual target consisted in a green circle presented at any position on the screen. The participant should respond as quickly and accurately as possible whether this green circle appeared at the same position as one of the yellow circles presented previously. After having responded or after time elapsed, a variable jittered inter-stimulus-interval (ISI; 0 ms or 2000 ms) occurred, followed by two feedback screens (2000 ms). A first feedback screen informed the participants of the monetary gain (“blank screen” for not-rewarded trials; “1 CHF” for rewarded trials; 1000 ms). It was followed by a second screen (1000 ms) with the cumulated amount of monetary reward (rewarded trials) or a blank screen (not-rewarded trials). At the end of every four trials, participants rated their mood level (max. 20 s). Correct response was associated with monetary gain (1 CHF) in the rewarded trials, whereas correct response was not associated with monetary gain (0 CHF) in the not-rewarded trials. In this version of the Fribourg reward task, participants performed the same reward task in two blocks of 20 min each. The first block was devoid of experimental stressor (i.e. control condition), while the second block included stressor manipulation (i.e. stress condition) consisting in the administration of unpredictable mild electric shocks. All four type of trials (reward  $\times$  load) were randomly

distributed within each block. In order to get used to the task, each subject performed a training outside the scanner before starting the scanning session. Further, participants were told that they would obtain the total amount of earned money in cash at the end of the scanning session. Figure 7.1 details the timing of an event in the rewarded and not-rewarded trials. The task was implemented using E-Prime Professional (Version 2.0.10.353, Psychology Software Tools, Inc.). Stimuli were presented via goggles (VisualStimDigital MR-compatible video goggles; Resonance Technology Inc., Northridge, CA, USA) with a visual angle of 60°, a resolution of 800x600 pixels and 60Hz refresh rate.

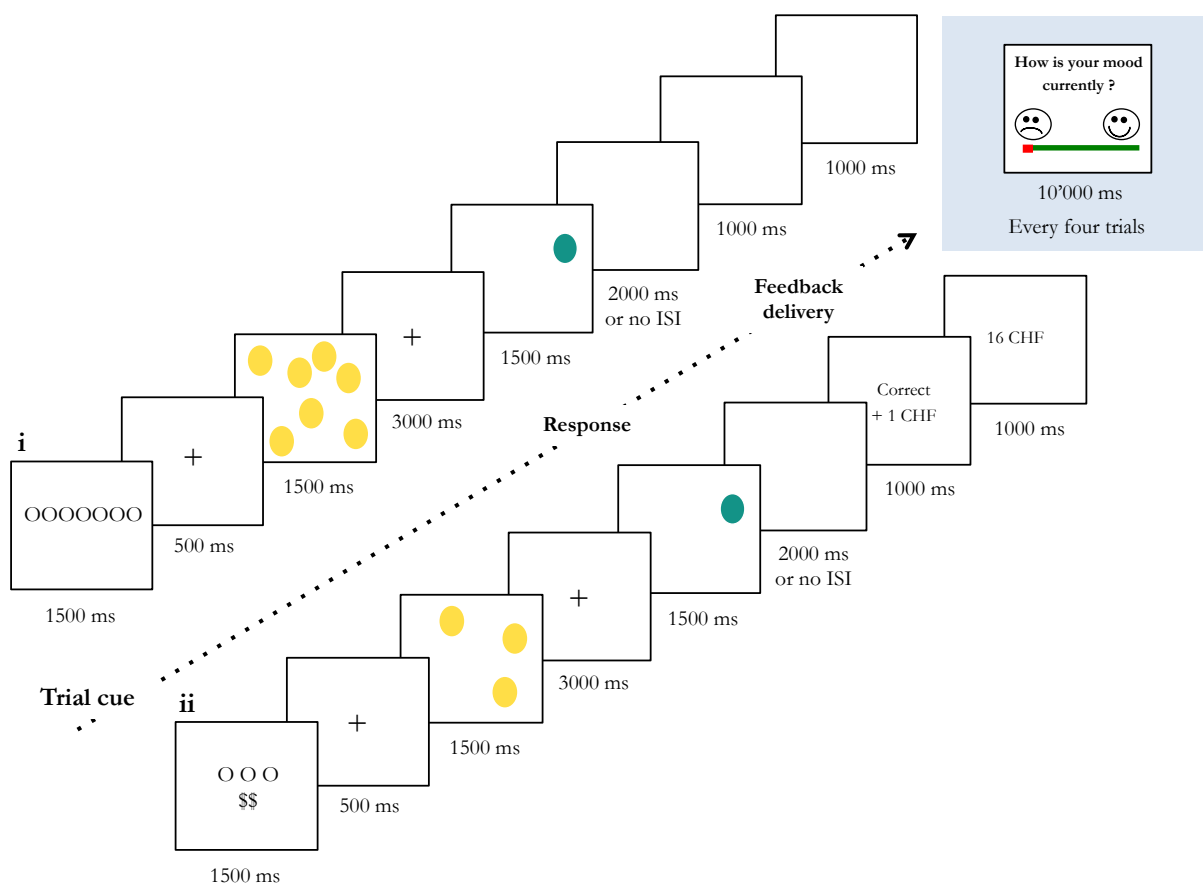

Figure 7.1. Illustration of the Fribourg reward task. (i) A not-rewarded trial under high working memory load, and (ii) a rewarded trial under low working memory load.

### 7.3.4 Experimental stress induction

Stress was induced through the administration of unpredictable mild electric shocks during the second block of the task. Shocks were delivered on the external side of the participants' non-dominant left hand via 6-mm Ag/AgCl electrodes, using a non-ferromagnetic shock box (Psychlab system, Contact Precision Instruments, London, UK) positioned on a table next to the scanner. Prior to the MRI data acquisition, the individual shock intensity was established for each participant by administering a standard shock work-up procedure to determine an intensity evaluated as "aversive, but not painful" by the participant (O. J. Robinson et al., 2011). The intensity of the shock could range from 0 to was 5 mA (milliamper) with shock intensity characterized by a number ranging from 0 to 255 ( $M = 101.2 \pm 5.7$ ). The effectiveness of this experimental manipulation has been widely evidenced to induce a stress response characterized by increased arousal, cortisol concentrations, negative mood and state of anxiety (Balderston, Hale, et al., 2017; Balderston, Vytal, et al., 2017; Bogdan & Pizzagalli, 2006; J. M. Choi et al., 2015; Grillon et al., 1993; Torrisi et al., 2018, 2016).

### 7.3.5 Effect of the experimental acute stressor on self-reported mood

At the end of every four trials of the event-related Fribourg reward task, participants reported their mood using a Visual Analog Mood Scale (scaled from 0 'very negative mood' to 9 'very positive mood') adapted from Nyenhuis and colleagues (1997). Then, self-reported ratings were entered into SPSS (IBM SPSS Statistics, Version 25.0, Armonk, NY, USA).

### 7.3.6 MR data acquisition

A Siemens TrioTim syngo 3.0-Tesla whole-body scanner (Erlangen, Germany) equipped with a radio frequency 32-channel head coil was used to acquire the functional MRI images. MRI acquisition included 3D T1-weighted (MPRAGE) images, collected with the following settings: sagittal slices: 176 ; slice thickness: 1.0 mm ; FOV:  $256 \times 256 \text{ mm}^2$  ; matrix size:  $256 \times 256$  ; voxel size:  $1 \times 1 \times 1 \text{ mm}^3$  ; TR: 1950 ms ; TE: 2.2 ms ; flip angle:  $90^\circ$ . The functional event-related task-based MRI acquisition was collected using EPI pulse sequence with the following settings: interleaved ascending slices: 38 ; slice thickness: 3.0 mm ; FOV:  $230 \times 230 \text{ mm}^2$  ; matrix size:  $64 \times 64$  ; voxel size:  $3.6 \times 3.6 \times 3 \text{ mm}^3$  ; TR: 2000 ms ; TE: 30 ms ; flip angle:  $90^\circ$ .



### 7.3.7 Behavioral data analyses

#### 7.3.7.1 Working memory performance

A  $2 \times 2 \times 2 \times 2$  repeated measures ANOVA with group (HC vs HV) as between-subject factor, and stress (stress vs control), reward (rewarded vs not-rewarded), and WM load (high vs low) as within-subject factors was conducted on response accuracy scores and reaction times using SPSS (IBM SPSS Statistics, Version 25.0, Armonk, NY, USA).

#### 7.3.7.2 Self-reported mood ratings during the Fribourg reward task

To test the effect of the experimental stress on participants' mood, we conducted a  $2 \times 2 \times 2 \times 2$  repeated measures ANOVA on participants' mood ratings during the Fribourg reward task, with group (HC vs HV) as between-subject factor and stress (stress vs control), reward (rewarded vs not-rewarded), and WM load (high vs low) as within-subject factors, using SPSS (IBM SPSS Statistics, Version 25.0, Armonk, NY, USA).

### 7.3.8 fMRI data analysis

The preprocessing and statistical analyses of the structural and functional MRI data were performed with AFNI software package (Cox, 1996).

#### 7.3.8.1 Task-based fMRI data preprocessing

T1-weighted (MPRAGE) images were first processed with the standard FreeSurfer (version 6.0.0) pipeline (Fischl, 2004) to obtain segmentation masks corresponding to the brain (skull-stripped), white matter, and ventricles. The preprocessing was performed to the EPI data using the AFNI *afni\_proc.py* script with the following steps: despiking the time-series (despike), correcting for slice timing (tshift), volume co-registering to the participants' corresponding anatomical (3D T1-weighted) image (align), volume registration across the timeseries (volreg), blurring within the whole-brain mask (blur), normalization (scale), and regressors modeled (regress). The EPI data were corrected for motion (averaged motion per volume:  $0.049 \pm 0.015$ ) by censoring EPI volumes and their preceding volume where the derivative of the motion regressors from *3dvolreg* had a Euclidean norm above 0.3 mm. Volumes with more than 10% voxel outliers were censored as well. Over the initial 32 age- and gender-matched participants selected,

none reached these exclusion criteria. The preprocessed EPI timeseries were then warped to MNI space using the ICBM 2009a Nonlinear Symmetric atlas (Fonov et al., 2009), and spatially smoothed using an isotropic 6 mm FWHM Gaussian filter. Lastly, a group-level grey matter mask was created by averaging and thresholding binary masks at 0.75 overlap (Torrissi et al., 2015).

### 7.3.8.2 Task-based fMRI data analysis

Statistical group-level analyses was completed within the framework of the GLM, as implemented in the AFNI program *3dDeconvolve*. The GLM included group (HC vs HV) as between-subject fixed factor, stress (stress vs control), reward (rewarded vs not-rewarded), and WM load (high vs low) as within-subject fixed factors, and subjects as a random factor. A  $2 \times 2 \times 2 \times 2$  repeated measures ANOVA was run to determine the effect of the (i) group, (ii) unpredictable stressor, (iii) monetary reward, and (iv) WM load on the BOLD activations. With the aim of testing *a priori* hypotheses focusing on the interaction effect between group, stress, reward, and WM load on the striatal reactivity during the anticipation and delivery phases, ROI were defined by using the maximum probability atlas of Desai DKD maps implemented in FreeSurfer version 6.0.0 (Desikan et al., 2006; Destrieux et al., 2010; Fischl, 2004). Specifically, the ROI comprised striatal regions including the bilateral NAcc, caudate nucleus, and putamen. In order to correct the analyses for multiple comparisons, a Bonferroni's correction approach was applied by dividing p-value of .05 by the number of ROI ( $p\text{-value} = p\text{-value} / 3 = 0.02$ ). Additionally, a cluster-based approach was conducted to correct whole-brain activation maps for multiple comparisons by running 10'000 Monte Carlo simulations using the AFNI program *3dClustSim*. A mixed ACF is comprised in this updated *3dClustSim* version in order to better model non-Gaussian noise structure (Cox et al., 2017). EPI data were then thresholded using a voxelwise p-value threshold of  $p < 0.001$ , and a minimum cluster size of  $k = 17$ , which corresponds to a whole-brain, cluster-level alpha of  $p < 0.05$ . From the three ROI contrast maps, individual parameter estimates were extracted by averaging the activation of all voxels located in the ROI for each participant and condition. Next, parameter estimates were entered into SPSS.

## 7.4 RESULTS

### 7.4.1 Behavioral results

#### 7.4.1.1 Working memory performance: response accuracy

Response accuracy was analyzed according to a fourfold interaction between group (HC vs HV), stress (stress vs control), reward (rewarded vs not-rewarded), and WM load (high vs low) by means of repeated measures ANOVA. As predicted, the main effect of reward was significant, with increased response accuracy in rewarded trials ( $M = 82.1\%$ ;  $SE = 1.86\%$ ) compared to not-rewarded trials ( $M = 79.8\%$ ;  $SE = 2.05\%$ ),  $F_{(1,30)} = 3.2$ ,  $p_{one-tailed} < 0.05$ ,  $\eta^2 = 0.10$ . Additionally, a significant main effect of WM load indicated decreased response accuracy in the high WM load condition ( $M = 74.1\%$ ;  $SE = 2.1\%$ ) compared to the low WM load condition ( $M = 87.8\%$ ;  $SE = 1.9\%$ ),  $F_{(1,30)} = 78.5$ ,  $p_{two-tailed} < 0.001$ ,  $\eta^2 = 0.72$ . Interestingly, a significant main effect of stress indicated increased response accuracy in the stress condition ( $M = 83.4\%$ ;  $SE = 2.0\%$ ) compared to the control condition ( $M = 78.5\%$ ;  $SE = 2.0\%$ ),  $F_{(1,30)} = 8.1$ ,  $p_{two-tailed} < 0.01$ ,  $\eta^2 = 0.21$ . Additionally, a significant twofold interaction effect (reward  $\times$  load) occurred ( $F_{(1,30)} = 5.1$ ,  $p_{two-tailed} < 0.05$ ,  $\eta^2 = 0.15$ ). Post-hoc analyses showed diminished response accuracy in the not-rewarded trials ( $M = 71.7\%$ ;  $SE = 2.3\%$ ) compared to the rewarded trials ( $M = 76.5\%$ ;  $SE = 2.3\%$ ) in the high WM load condition ( $t_{(31)} = -2.38$ ,  $p < 0.05$ ), while response accuracy didn't differ significantly in the low WM load condition between the not-rewarded trials ( $M = 87.9\%$ ;  $SE = 2.2\%$ ) and the rewarded trials ( $M = 87.7\%$ ;  $SE = 1.9\%$ ) ( $t_{(31)} = 0.20$ ,  $p > 0.05$ ). However, neither threefold interaction effect (group  $\times$  stress  $\times$  reward) nor fourfold interaction effect (group  $\times$  stress  $\times$  reward  $\times$  load) were detected on response accuracy.

#### 7.4.1.2 Working memory performance: reaction times (RT)

The fourfold interaction (group  $\times$  stress  $\times$  reward  $\times$  load) repeated measures ANOVA on RT showed a significant main effect of load, with slower RT in the high WM load condition ( $M = 804.0$  ms;  $SE = 15.7$  ms) compared to the low WM load condition ( $M = 711.6$  ms;  $SE = 16.0$  ms),  $F_{(1,30)} = 112.9$ ,  $p_{two-tailed} < 0.001$ ,  $\eta^2 = 0.79$  (see Panel A in Figure 7.2). A significant main effect of stress indicated faster RT during the stress condition ( $M = 730.7$  ms;  $SE = 16.7$  ms) than during the control condition ( $M = 784.8$  ms;  $SE = 16.4$  ms),  $F_{(1,30)} = 17.9$ ,  $p_{two-tailed} < 0.001$ ,  $\eta^2 = 0.37$ . Critically, a significant twofold interaction effect (stress  $\times$  reward) appeared ( $F_{(1,30)} = 4.21$ ,  $p_{two-tailed} < 0.05$ ,  $\eta^2 = 0.12$ ). Post-hoc analyses demonstrated that RT were faster in the

rewarded trials ( $M = 773.1$  ms;  $SE = 15.2$  ms) compared to the not-rewarded trials ( $M = 796.5$  ms;  $SE = 18.4$  ms) in the control condition, whereas this enhancing effect of reward disappeared in the stress condition in which accuracy performance didn't differ between the rewarded trials ( $M = 733.8$  ms;  $SE = 18.1$  ms) and the not-rewarded trials ( $M = 727.7$  ms;  $SE = 17.6$  ms). However, neither threefold interaction effect (group  $\times$  stress  $\times$  reward) nor fourfold interaction effect (group  $\times$  stress  $\times$  reward  $\times$  load) were detected on response accuracy. The panel A and panel B in Figure 7.2 describe the main and interaction effects of stress and reinforcement on reaction times and response accuracy, respectively.

### 7.4.1.3 Self-reported mood ratings during the Fribourg reward task

Next, we assessed whether self-reported mood ratings were influenced by stress (stress vs control), reward (rewarded vs not-rewarded), and WM load (high vs low), and whether these factors affected differently self-reported mood ratings in HV compared to HC. In accordance with our hypotheses, the fourfold repeated measures ANOVA showed a significant main effect of stress ( $F_{(1,30)} = 3.3$ ,  $p_{one-tailed} < 0.05$ ,  $\eta^2 = 0.10$ ), with decreased positive mood in the stress condition ( $M = 6.7$ ;  $SE = 0.3$ ) compared to the control condition ( $M = 6.9$ ;  $SE = 0.3$ ). As expected, a significant main effect of reward occurred ( $F_{(1,30)} = 4.11$ ,  $p_{one-tailed} < 0.05$ ,  $\eta^2 = 0.12$ ), with increased positive mood in the rewarded trials ( $M = 6.9$ ;  $SE = 0.3$ ) compared to the not-rewarded trials ( $M = 6.7$ ;  $SE = 0.3$ ) (see Panel C in Figure 7.2). However, neither threefold interaction effect (group  $\times$  stress  $\times$  reward) nor fourfold interaction effect (group  $\times$  stress  $\times$  reward  $\times$  load) were detected on self-reported mood ratings.

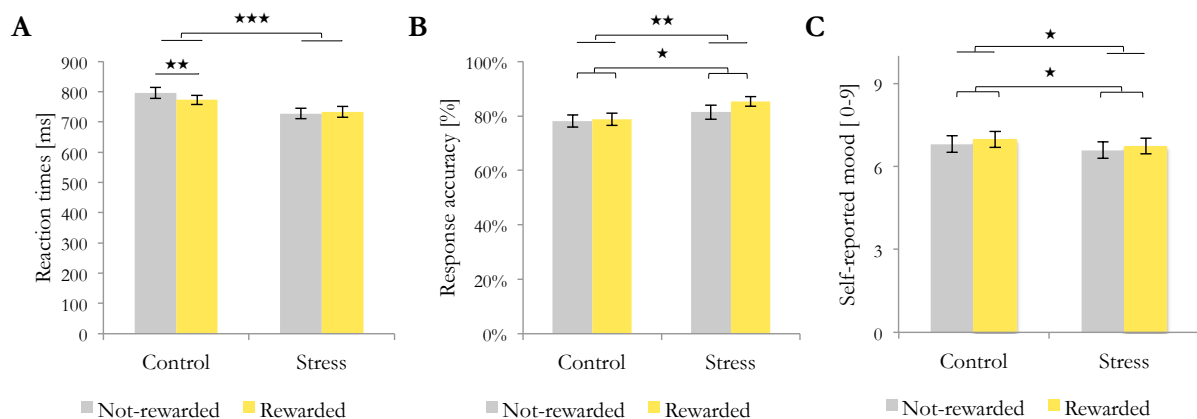

Figure 7.2. Effect of stress induction and reward on the working memory performance and self-reported mood ratings during the Fribourg reward task. Mean and standard error as a function of stress induction (stress vs control) and reinforcement schedule (rewarded trials vs not-rewarded trials) for the (A) reaction times, (B) response accuracy, and (C) self-reported mood scaled from 0 'very negative mood' to 9 'very positive mood'.  $^{\dagger}p_{(one-tailed)} < .05$   $^*p < .05$ ,  $^{**}p < .01$ ,  $^{***}p < .001$ .

## 7.4.2 fMRI results

### 7.4.2.1 Striatal activations during anticipation

During the anticipation phase, a significant threefold interaction effect (group  $\times$  stress  $\times$  load) occurred in the bilateral NAcc ( $F_{(1,30)} = 7.1$ ,  $p_{two-tailed} < 0.01$ ,  $\eta^2 = 0.19$ , Bonferroni-corrected). Post-hoc analyses demonstrated a significant reduction in NAcc reactivity in the stress condition compared to the control condition in HV, but only in the low WM load condition ( $t_{(15)} = 2.89$ ,  $p_{two-tailed} < 0.05$ , Bonferroni-corrected). Also, a significant main effect of group on bilateral caudate nucleus activation occurred ( $F_{(1,30)} = 6.1$ ,  $p_{two-tailed} < 0.05$ ,  $\eta^2 = 0.17$ , Bonferroni-corrected), indicating significantly decreased recruitment of the nucleus caudate in HV compared to HC, irrespective of stress exposure, reinforcement schedule or WM load (see Figure 7.3).

#### ANTICIPATION

Group differences showing significant (A) main effect of group in the caudate nucleus, and (B) threefold interaction effect (group  $\times$  stress  $\times$  load) in the nucleus accumbens.

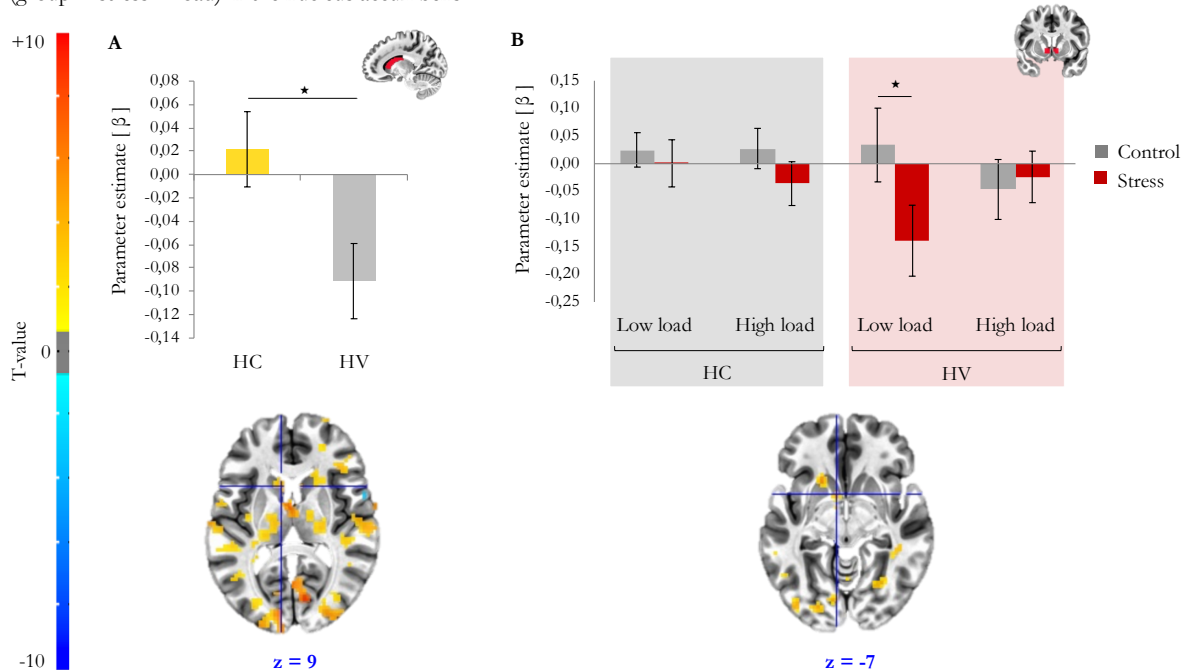
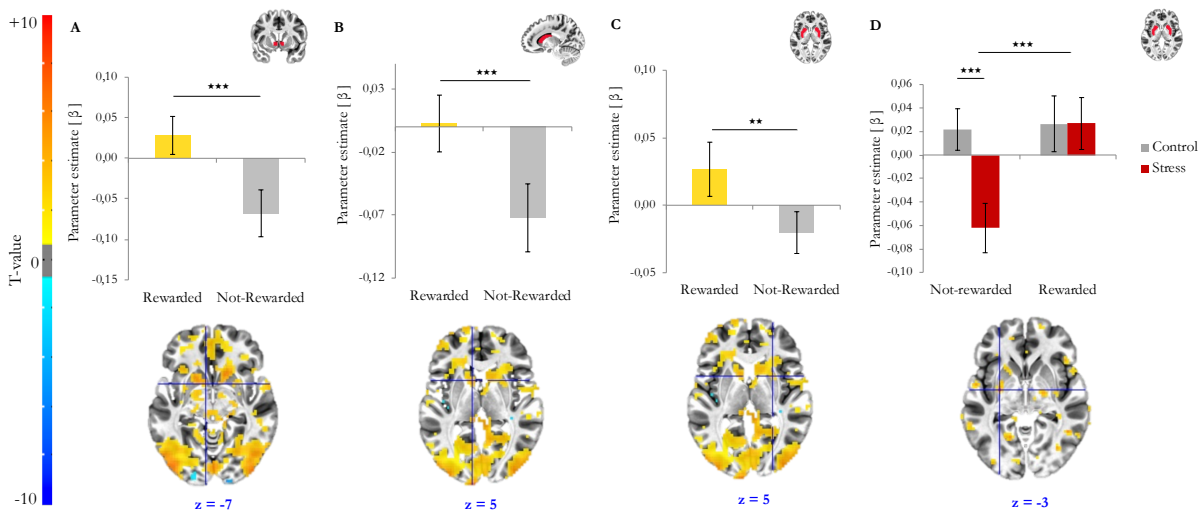

Figure 7.3. Illustration of the main effect of group comparing the healthy adults without (HC, healthy control) and with (HV, healthy vulnerable) increased risk for major depression, and threefold interaction effect (group  $\times$  stress  $\times$  load) during the anticipation phase. (A) Significant reduced recruitment of the bilateral caudate nucleus in the HV. (B) Significant reduced activation in the bilateral nucleus accumbens in the HV during the stress condition vs control condition, but only in the low load compared to high load conditions. Parameter estimates ( $\beta$  weights) mean with standard errors are presented at the top of the figure. Statistical parametric maps corresponding to the contrasts of interest during anticipation are presented below. These whole-brain activations are corrected for multiple comparisons, but thresholded here at 0.05 for visualization purpose.  $*p < .05$ ,  $**p < .01$ ,  $***p < .001$ .

Irrespective of groups, a significant main effect of reward showed increased activation in rewarded trials compared to not-rewarded trials in the bilateral NAcc ( $F_{(1,30)} = 23.1$ ,  $p_{two-tailed} < 0.001$ ,  $\eta^2 = 0.44$ , Bonferroni-corrected), in the bilateral caudate nucleus ( $F_{(1,30)} = 14.3$ ,  $p_{two-tailed} < 0.001$ ,  $\eta^2 = 0.32$ , Bonferroni-corrected), and in the bilateral putamen ( $F_{(1,30)} = 11.8$ ,  $p_{two-tailed} < 0.01$ ,  $\eta^2 = 0.28$ , Bonferroni-corrected). Additionally, a significant twofold interaction effect (stress  $\times$  reward) was found in the bilateral putamen ( $F_{(1,30)} = 13.6$ ,  $p_{two-tailed} < 0.001$ ,  $\eta^2 = 0.31$ , Bonferroni-corrected). Post-hoc analyses evidenced significantly increased putamen reactivity in rewarded trials compared to not-rewarded trials in the stress condition ( $t_{(31)} = 4.86$ ,  $p_{two-tailed} < 0.001$ , Bonferroni-corrected), whereas this difference was not significant anymore in the control condition ( $t_{(31)} = 0.28$ ,  $p_{two-tailed} > 0.05$ , Bonferroni-corrected) (see Figure 7.4). However, neither threefold interaction effect (group  $\times$  stress  $\times$  reward) nor fourfold interaction effect (group  $\times$  stress  $\times$  reward  $\times$  load) were detected during the anticipation phase.

#### ANTICIPATION

In HC and HV individuals, significant main effects of reward in the (A) nucleus accumbens, (B) caudate nucleus and (C) putamen, and (D) twofold interaction effect (stress  $\times$  reward) in the putamen.



**Figure 7.4.** Illustration of the main effect of reward and the twofold interaction effect (stress  $\times$  reward) that occurred during the anticipation phase in the healthy adults without (HC, healthy control) and with (HV, healthy vulnerable) increased risk for major depression. Significant increased reactivity to cued rewards (rewarded vs not-rewarded) in the bilateral (A) nucleus accumbens (NAcc), (B) caudate nucleus, and (C) putamen. (D) Significant reduced activation in the bilateral putamen during the stress condition vs control condition, but only in not-rewarded trials. Parameter estimates ( $\beta$  weights) mean with standard errors are presented at the top of the figure. Statistical parametric maps corresponding to the contrasts of interest during anticipation are presented below. These whole-brain activations are corrected for multiple comparisons, but thresholded here at 0.05 for visualization purpose. \* $p < .05$ , \*\* $p < .01$ , \*\*\* $p < .001$ .

Table 7.2

Main and interaction effects for the within- and between-subject contrasts in the bilateral nucleus accumbens (NAcc), caudate nucleus, and putamen

Within-subjects contrasts	Stress	Reward	WM load	Anticipation									Delivery								
				NAcc			Caudate nucleus			Putamen			NAcc			Caudate nucleus			Putamen		
				$F_{(1,30)}$	$p$	$\eta^2$	$F_{(1,30)}$	$p$	$\eta^2$	$F_{(1,30)}$	$p$	$\eta^2$	$F_{(1,30)}$	$p$	$\eta^2$	$F_{(1,30)}$	$p$	$\eta^2$	$F_{(1,30)}$	$p$	$\eta^2$
Stress	Stress vs Control			3.05	0.09	0.09	1.92	0.18	0.06	4.50	0.04	0.13	0.73	0.40	0.02	<b>13.54</b>	<b>0.00</b>	<b>0.31</b>	<b>8.09</b>	<b>0.01</b>	<b>0.21</b>
Reward		R vs NR		<b>23.15</b>	<b>0.00</b>	<b>0.44</b>	<b>14.3</b>	<b>0.00</b>	<b>0.32</b>	<b>11.80</b>	<b>0.00</b>	<b>0.28</b>	1.12	0.28	0.04	5.73	0.02	0.16	0.50	0.49	0.02
Load			High vs Low	0.00	0.99	0.00	2.2	0.15	0.07	2.23	0.15	0.07	<b>32.13</b>	<b>0.00</b>	<b>0.52</b>	<b>18.38</b>	<b>0.00</b>	<b>0.38</b>	5.42	0.03	0.15
Stress × Group	Stress vs Control			0.21	0.65	0.00	2.7	0.11	0.08	0.77	0.39	0.03	0.09	0.77	0.00	0.03	0.90	0.00	0.05	0.83	0.00
Reward × Group		R vs NR		0.00	0.96	0.00	0.02	0.88	0.00	0.003	0.96	0.00	0.32	0.58	0.01	0.61	0.44	0.02	0.05	0.83	0.00
Load × Group			High vs Low	0.36	0.55	0.01	0.02	0.89	0.00	0.31	0.58	0.01	<b>8.29</b>	<b>0.01</b>	<b>0.22</b>	1.78	0.19	0.06	1.00	0.33	0.03
Stress × Reward	Stress vs Control	R vs NR		0.15	0.70	0.01	0.43	0.52	0.01	<b>13.63</b>	<b>0.00</b>	<b>0.31</b>	0.06	0.81	0.00	0.27	0.61	0.01	3.88	0.06	0.11
Stress × Load	Stress vs Control		High vs Low	3.16	0.09	0.10	2.77	0.11	0.08	1.63	0.21	0.05	0.32	0.58	0.01	0.02	0.93	0.00	0.06	0.81	0.00
Reward × Load		R vs NR	High vs Low	0.32	0.58	0.01	0.13	0.72	0.00	0.02	0.90	0.00	<b>8.40</b>	<b>0.01</b>	<b>0.22</b>	<b>9.78</b>	<b>0.00</b>	<b>0.25</b>	1.04	0.32	0.03
Stress × Reward × Group	Stress vs Control	R vs NR		0.90	0.35	0.03	0.83	0.37	0.03	2.67	0.11	0.08	0.55	0.46	0.02	0.69	0.41	0.02	1.00	0.33	0.03
Stress × Load × Group	Stress vs Control		High vs Low	<b>7.09</b>	<b>0.01</b>	<b>0.19</b>	0.10	0.75	0.00	0.01	0.92	0.00	0.01	0.91	0.00	0.62	0.44	0.02	0.003	0.96	0.00
Reward × Load × Group		R vs NR	High vs Low	0.00	1.00	0.00	0.03	0.86	0.00	0.48	0.49	0.02	1.14	0.29	0.04	0.15	0.70	0.01	0.20	0.66	0.01
Stress × Reward × Load	Stress vs Control	R vs NR	High vs Low	0.96	0.33	0.03	5.23	0.03	0.15	0.30	0.59	0.01	0.42	0.52	0.01	0.10	0.75	0.00	0.74	0.40	0.02
Stress × Reward × Load × Group	Stress vs Control	R vs NR	High vs Low	1.12	0.30	0.04	0.65	0.43	0.02	4.68	0.04	0.14	2.62	0.12	0.08	0.07	0.80	0.00	1.11	0.30	0.04
Between-subjects contrasts	Group																				
Group	HC vs HV			0.98	.330	0.03	<b>6.14</b>	<b>0.019</b>	<b>0.17</b>	1.199	0.28	0.04	0.03	0.86	0.00	0.46	0.50	0.02	0.58	0.45	0.02

Note. Analyses of region-of-interest activations were corrected for multiple comparisons by applying a Bonferroni correction ( $p$ -value  $< p$ -value / 3  $< 0.02$ ); F, F-statistic with degrees of freedom for effect and error; HC, healthy control; HV, healthy vulnerable;  $\eta^2$ , partial eta squared; NR, not-rewarded; R, rewarded; WM, working memory. Partial eta squared ( $\eta^2$ ) represents the proportion of total variance accounted for by the factor, while excluding other factors from the total explained variance (i.e. nonerror variation) in the repeated measures ANOVA (Pierce et al., 2004). Partial eta squared ( $\eta^2$ ) values range from 0 to 1.

### 7.4.2.2 Striatal activations during delivery

During the feedback notification, a significant main effect of stress was identified in the bilateral caudate nucleus ( $F_{(1,30)} = 13.5$ ,  $p_{two-tailed} < 0.001$ ,  $\eta^2 = 0.31$ , Bonferroni-corrected) and putamen ( $F_{(1,30)} = 8.1$ ,  $p_{two-tailed} < 0.05$ ,  $\eta^2 = 0.21$ , Bonferroni-corrected), indicating increased activation in the bilateral caudate nucleus and decreased deactivation in the bilateral putamen in the stress condition compared to the control condition. A significant main effect of load occurred in the bilateral NAcc ( $F_{(1,30)} = 32.1$ ,  $p_{two-tailed} < 0.05$ ,  $\eta^2 = 0.52$ , Bonferroni-corrected) and in the bilateral caudate nucleus ( $F_{(1,30)} = 18.4$ ,  $p_{two-tailed} < 0.05$ ,  $\eta^2 = 0.38$ , Bonferroni-corrected), showing increased activation in the low compared to high WM load conditions. A significant twofold interaction effect (group  $\times$  load) was revealed in the bilateral NAcc ( $F_{(1,30)} = 8.3$ ,  $p_{two-tailed} < 0.05$ ,  $\eta^2 = 0.22$ , Bonferroni-corrected). Post-hoc analysis indicated significant increased bilateral NAcc reactivity in the low WM load condition compared to high WM load condition in HV ( $t_{(15)} = -6.15$ ,  $p_{two-tailed} < 0.001$ , Bonferroni-corrected), whereas this was not the case in HC ( $t_{(15)} = -1.94$ ,  $p_{two-tailed} > 0.05$ , Bonferroni-corrected) (see Figure 7.5). Additionally, a significant twofold interaction effect (reward  $\times$  load) was revealed in the bilateral caudate nucleus ( $F_{(1,30)} = 9.8$ ,  $p_{two-tailed} < 0.05$ ,  $\eta^2 = 0.25$ , Bonferroni-corrected) and bilateral NAcc ( $F_{(1,30)} = 8.4$ ,  $p_{two-tailed} < 0.05$ ,  $\eta^2 = 0.22$ , Bonferroni-corrected). Post-hoc analyses indicated significantly higher striatal responsiveness in rewarded trials compared to not-rewarded trials following low WM load performance in the caudate nucleus ( $t_{(31)} = 4.05$ ,  $p_{two-tailed} < 0.001$ , Bonferroni-corrected) and in the NAcc ( $t_{(31)} = 2.45$ ,  $p_{two-tailed} < 0.05$ , Bonferroni-corrected), while this difference was not present anymore during reward delivery following high WM load performance (see Figure 7.5). However, neither threefold interaction effect (group  $\times$  stress  $\times$  reward) nor fourfold interaction effect (group  $\times$  stress  $\times$  reward  $\times$  load) were detected during the delivery phase. Additionally, whole-brain analyses were performed and regions significantly activated in these contrasts ( $p < 0.05$ , cluster-wise corrected) are presented in Table 7.3 (see also Table B.1 and Table B.2 in Appendix for a comprehensive report of whole-brain analysis in all conditions).



## DELIVERY

Significant main effect of stress in the (A) caudate nucleus in HC and HV individuals, and (B) significant twofold interaction effect (group  $\times$  load) in the nucleus accumbens.

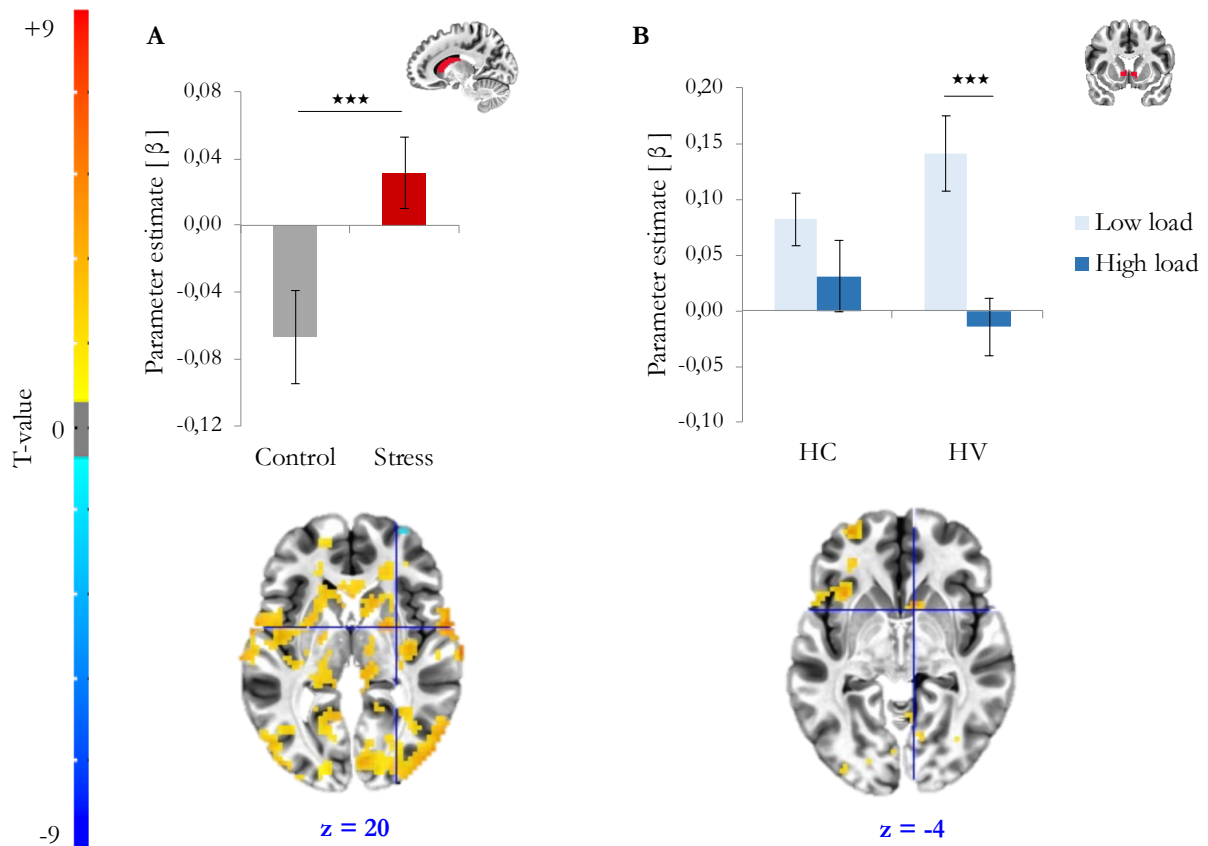

*Figure 7.5.* Illustration of the main effect of stress in the healthy adults without (HC, healthy control) and with (HV, healthy vulnerable) increased risk for major depression, and twofold interaction effect (group  $\times$  load) during the delivery phase. Significant increased reactivity during the stress condition compared to the control condition in the (A) bilateral caudate nucleus in both groups, and (B) significant reduced activation in the bilateral nucleus accumbens in the high compared to low cognitive load condition, but only in the HV. Parameter estimates ( $\beta$  weights) mean with standard errors are presented at the top of the figure. Statistical parametric maps corresponding to the contrasts of interest during anticipation are presented below. These whole-brain activations are corrected for multiple comparisons, but thresholded here at 0.05 for visualization purpose.  $*p < .05$ ,  $**p < .01$ ,  $***p < .001$ .

Table 7.3

*Significant whole-brain clusters (cluster-size corrected) for the main and interaction effects of interest during the (1) anticipation phase and (2) delivery phase in healthy control (HC) and healthy vulnerable (HV) individuals*

Activated clusters in brain regions	Side	MNI coordinates (LPI)			Cluster size	T-Value
		x	y	z		
<b>1. ANTICIPATION PHASE</b>						
Main effect of group: HC > HV						
-	-	-	-	-	-	-
Main effect of stress : stress > control conditions						
Middle temporal gyrus	R	62	-53	8	40	-4.70
Cerebellum	L	-5	-86	-35	35	-3.87
Lingual	L	-2	-68	8	25	-4.46
Cuneus	R	5	-80	14	25	-3.69
Precuneus	R	2	-56	65	19	-3.73
Inferior temporal gyrus	L	-59	-62	-11	18	-3.68
Lateral occipital gyrus	R	14	-104	8	18	-3.77
Main effect of reward : rewarded > not-rewarded trials						
Inferior temporal gyrus	L	-56	-68	-14	849	4.78
Inferior temporal gyrus	R	53	-65	-17	560	5.66
Superior parietal lobule	R	23	-83	50	152	5.92
Lingual	R	2	-83	-5	85	4.44
Postcentral	L	-41	-41	65	72	4.27
Area 17 (striate area)	L	-17	-71	11	34	6.04
Putamen	L	-20	14	-11	28	4.51
Precuneus	R	5	-44	56	24	4.49
Medial orbitofrontal	R	14	47	-17	19	3.95
Inferior temporal gyrus	L	-50	-50	-26	18	3.77
Main effect of WM load : high > low loads						
Lingual	L	-14	-86	-14	3187	7.98
Superior frontal gyrus	L	-5	8	53	52	4.73
Fusiform gyrus	R	32	-44	-20	25	5.88
Insula	R	35	23	5	22	4.78
Fusiform gyrus	R	41	-53	-23	17	4.18
Pars opercularis	R	53	17	-2	17	3.89
Interaction effect Stress × Reward						
-	-	-	-	-	-	-
Interaction effect Group × Stress × Load						
-	-	-	-	-	-	-

Activated clusters in brain regions	Side	MNI coordinates (LPI)			Cluster size	T-Value
		x	y	z		
<b>2. DELIVERY PHASE</b>						
Main effect of stress : stress > control conditions						
Lateral occipital gyrus	L	-26	-56	62	58	4.77
Superior parietal lobule	L	-62	-23	50	56	3.81
Postcentral	L	-29	-89	38	33	3.87
Inferior parietal lobule	L	-41	-14	59	25	4.14
Precentral	L	-41	44	35	24	3.86
Rostral middle frontal cortex	L	-26	-98	23	23	3.83
Lateral occipital gyrus	R	50	-83	-2	22	3.69
Lateral occipital gyrus	R	20	11	23	21	3.71
Caudate	L	-5	11	38	20	4.66
Superior frontal gyrus	R	38	-5	56	19	3.84
Precentral	R	68	-17	35	18	4.23
Supramarginal gyrus	L	-35	-95	14	17	3.68
Main effect of reward : rewarded > not-rewarded trials						
Lateral occipital gyrus	L	-44	-89	-14	5287	7.57
Superior frontal gyrus	L	-2	59	14	1471	7.56
Inferior parietal lobule	R	32	-74	56	429	4.07
Inferior parietal lobule	L	-32	-74	56	244	4.18
Superior temporal gyrus	R	50	23	-17	179	5.27
Lateral orbitofrontal cortex	L	-47	23	-14	170	5.75
Precentral	L	-50	8	38	92	6.01
Superior parietal lobule	L	-14	-68	59	84	-4.00
Rostral middle frontal cortex	R	53	41	20	65	3.84
Rostral middle frontal cortex	R	41	62	-8	46	5.22
Inferior parietal lobule	L	-56	-68	32	41	4.04
Middle temporal gyrus	R	65	-29	-8	31	4.42
Rostral middle frontal cortex	L	-53	32	23	29	3.96
Supramarginal gyrus	L	-68	-29	23	24	-4.08
Superior parietal lobule	R	8	-65	59	22	-3.84
Pars orbitalis	R	35	47	-17	20	3.68
Supramarginal gyrus	R	68	-32	35	17	-4.03
Main effect of WM load : high > low loads						
Lingual gyrus	R	2	-95	-11	667	-4.17
Putamen	L	-20	17	-11	200	-4.19
Lateral occipital gyrus	L	-44	-83	-17	126	-3.68
Lateral occipital gyrus	R	50	-74	-14	52	-3.95
Precentral	L	-50	5	38	31	-6.27
Postcentral	R	32	-38	44	27	-4.69
Postcentral	L	-53	-23	44	26	-4.72
Postcentral	R	53	-29	59	24	-3.97
Interaction effect Group × Load : HC > HV in the low load condition						
Hippocampus	R	23	-14	-23	17	5.98
Interaction effect Group × Load : high > low loads in HV						
Lateral occipital gyrus	R	29	-89	-14	386	3.82
Putamen	L	-20	17	-11	150	4.71
Lateral occipital gyrus	L	-23	-98	26	73	5.30
Lateral occipital gyrus	R	29	-92	26	32	3.71

Activated clusters in brain regions	Side	MNI coordinates (LPI)			Cluster size	T-Value
		x	y	z		
Interaction effect Reward × Load	-	-	-	-	-	-
Interaction effect Group × Stress × Load	-	-	-	-	-	-

*Note.* Whole-brain activations presented for every specific contrasts are corrected for multiple comparisons using a cluster-based approach with a voxelwise p-value threshold of  $p < 0.001$  and a minimum cluster size of  $k = 17$ , which corresponds to a cluster-level alpha of  $p < 0.05$ . HC, healthy controls; HV, healthy vulnerable individuals; L, left ; R, right ; LPI means that x increases from Left to Right, y increases from Posterior to Anterior, z increases from Inferior to Superior.

## 7.5 DISCUSSION

Our third empirical work investigated the effect of stress exposure on the anticipation and delivery phases of the reward processing as potential vulnerability factor for MDD. Specifically, we explored whether stress exposure affects differentially striatal reactivity in HV compared to HC during the anticipation and delivery of rewards. Additionally, we examined, in an exploratory way, whether the level of cognitive effort required in the task modulates differentially the effect of stress exposure on reward processing in HV compared to HC in both phases. As expected, stress induction successfully amplified self-reported negative mood in participants (Bogdan & Pizzagalli, 2006; Grillon & Ameli, 1998; Torrisi et al., 2016), while rewarded trials were associated with significantly increased positive mood and enhanced behavioral performance. Of clinical importance, stress reduced the ventral striatal responses in HV during the anticipation phase, regardless of reinforcement schedule. This effect was modulated by cognitive load, with stronger stress-induced effect on the ventral striatum in the low compared to high cognitive load conditions. Further, HV presented a reduced dorsal striatum recruitment in all conditions during the anticipation phase compared to the HC. During the delivery phase, the HV showed reduced ventral striatal responsiveness following high cognitive effort, suggesting adverse effects of cognitive effort on ventral striatal reactivity during the feedback notification. Regardless of MDD vulnerability, stress exposure increased the dorsal striatum reactivity to reward cues in both groups during the anticipation phase, whereas we expected this pattern occurring only in the HC. These findings were mirrored by a stress enhancing effect on performance in both groups, with higher response accuracy and faster reaction times under stress exposure. Also, both groups showed significant reactivity to reward cues in the ventral and dorsal striatum during reward anticipation. Increased striatal responsiveness to reward cues was supported by enhanced performance in the rewarded trials in both groups. During the delivery phase, stress strengthened dorsal striatal responses in both group, irrespective of reinforcement schedule and cognitive load. Surprisingly, groups didn't differ in their striatal responsiveness to rewards, nor did stress affect groups differentially in their striatal reactivity to rewards during the anticipation and delivery phases. Moreover, groups did not differ in reaction times and response accuracy as a function of reward, stress exposure or cognitive load.

### 7.5.1 Group differences in striatal reactivity

Convergent with the pattern observed in MDD patients (Berghorst et al., 2013; Bogdan & Pizzagalli, 2006), exposure to unpredictable acute stress showed adverse effects on the ventral striatum activation in HV during the anticipation phase, irrespective of reinforcement schedule. Of primary importance, cognitive load modulated the effect of stress on the ventral striatal responses. When the cue indicated low cognitive load to exert, stress exposure induced stronger decreased activation in the ventral striatum of the HV. One hypothesis that might explain increased stress-induced effects preceding low-demanding cognitive effort in the ventral striatum is that stress exposure might catch more attentional focus when low cognitive load is required leading potentially to increased threat-related ruminations (for reviews see: Bourke et al., 2010; Peckham et al., 2010). The ventral striatum is particularly implicated in encoding the valence of incentives and in reward learning, informing consecutively the dorsal striatum about the motivational value of potential outcomes (Hassan & Benarroch, 2015). Therefore, individuals at increased vulnerability to MDD might have a reduced ability to evaluate the motivational valence of incentives resulting in increased difficulty to implement and to maintain motivated behaviors, specifically in contexts that are less cognitively demanding (O'Doherty et al., 2004; Schonberg et al., 2007). Interestingly, HV showed decreased reactivity in the ventral striatum following the exertion of higher cognitive effort. This suggests that in HV, the increased engagement of cognitive resources during the task might have reduced the availability of the ventral striatum for evaluating the incentive value during the feedback notification.

Supporting evidence indicating a diminished recruitment of the caudate nucleus in MDD patients (for a review see: Dillon et al., 2014), HV showed reduced caudate nucleus activation in all conditions during the anticipation phase. This is in line with findings that demonstrated a diminished caudate volume in MDD patients, with a lower volume associated with stronger anhedonic symptoms (Pizzagalli et al., 2009). Notably involved in feedback-driven contingency learning (Tricomi & Fiez, 2012) and in goal-directed behaviors (Grahn et al., 2008; Schwabe & Wolf, 2010) in humans, reduced reactivity in the caudate nucleus might give rise to an impaired ability to learn action-reward and stimulus-reward associations, and therefore might cause an increased difficulty to engage in motivated behaviors (Dillon et al., 2014). Contrary to our hypotheses and to clinical data in MDD patients, HV showed no difference in their neural and behavioral reactivity to monetary rewards, nor in the stress-induced effects on reward reactivity.

### **7.5.2 Stress-induced effect in striatal regions**

Consistent with prior research pointing to the stress-induced amplification of “incentive-triggered motivation” (Kumar et al., 2014; Pool et al., 2015), the induction of stress strengthened the dorsal striatum reactivity to reward cues in both groups, in the putamen specifically. Moreover, behavioral performance supported the increased stress-related activations in the dorsal striatum, as reflected by the stress enhancing effect on reaction times and response accuracy. Notably, the putamen has been implicated in the planning and implementation of actions (Grahn et al., 2008; Schwabe & Wolf, 2010). Therefore, the engagement of the dorsal striatum under stress exposure might reflect a similar mechanism evidenced in the development of compulsive-like seeking behaviors toward rewards (Koob, 2013; Koob & Le Moal, 2001; Nikolova & Hariri, 2012; Volkow & Morales, 2015). Stress exposure might increase arousal and trigger a transition from voluntary to compulsive-like seeking behaviors, indicated by a shift in the striatal regions engaged in the processing of rewarding stimuli, from the ventral striatum involved in reward valuation to the dorsal striatum implicated in the implementation of actions and habit formation (Everitt & Robbins, 2013; Malvaez & Wassum, 2018). In line with the stress-induced amplification of the dorsal striatal reactivity to reward cues during the anticipation phase, stress exposure potentiated the dorsal striatum activation in both groups during the delivery phase, regardless of monetary gains or of the level of cognitive effort exerted. These results might converge with the idea that stress could facilitate simple stimulus-response processes and procedural memory underpinned by enhanced dorsal striatum activation as reported in rodents (Quirarte et al., 2009) and humans (Schwabe et al., 2007).

### **7.5.3 Modulation of the striatal responses by cognitive load**

Cognitive effort engaged in the task influenced the ventral striatal reactivity in HV during the feedback notification, with the exertion of higher cognitive effort resulting in diminished ventral striatal responsiveness regardless of reinforcement schedule or of stress exposure. Based on primate studies (Schultz, 2000), the ventral striatum was shown to react in particular to unpredicted rewards during the delivery phase, leading to the learning of action-outcome and then cue-outcome associations. Therefore, the present results might indicate that the engagement of higher cognitive effort might reduce the ability of vulnerable individuals to learn the contingency between instrumental actions and their positive consequences. Additionally, the level of cognitive load modulated reward responsiveness in both groups during the delivery phase. Specifically, our empirical work indicates that the ventral and dorsal striatal reactivity to monetary rewards was

significantly impaired following the exertion of higher cognitive effort during the task. To date, the literature exploring the interplay between the reward processes and the effort to exert remains scarce. To our knowledge, only one study explored the cumulative effect of cognitive load on stress-induced reward responsiveness. Contrasting with our results, this study reported stronger activation of the ventral striatum in response to positive feedback following more demanding effort among healthy adults (Satterthwaite et al., 2012). Further investigation is needed to clarify these conflicting findings and to elaborate a comprehensive understanding about how cognitive resources at disposal modulate the effect of stress exposure on reward processing.

#### **7.5.4 Limitations**

The limitations of this empirical work deserve mention. First, although the negative mood ratings in response to the stress manipulation met our expectations, no physiological measures supported the subjective reports to confirm that the stress manipulation induced an increased reactivity of the biological stress system. Second, due to our within-subject design and to the completion of the two blocks (i.e. control and stress conditions) on the same day, the two blocks could not be randomized with the purpose of avoiding potential bleeding of negative affects elicited by the stress condition into the control condition. However, the strength of this design relies on the within-subject manipulation of the stressor with the avoidance of methodological concerns raised by scanning on different days. Due to the small sample size, an ultimate limitation was the inability to assess how offspring's age at the onset of parental MDD, and the duration of parent's depressive episodes might act as a moderation effect. Altogether, these results should be regarded as preliminary with a need for replication.

#### **7.5.5 Conclusion**

In sum, this empirical work indicates that stress exposure might have adverse effects on the ability of individuals at increased risk for MDD to evaluate and to learn the motivational value of incentives. In particular, the effect of stress exposure on these reward functions might be modulated by the level of cognitive resources at disposal. Also, the decreased dorsal striatal recruitment during the anticipation phase suggests that HV might have increased difficulties to engage in goal-oriented behaviors, resulting possibly in stronger risk for developing anhedonic symptoms. These findings might open new avenues to build up a better understanding of the role played by stress exposure in the vulnerability to major depression, and how it might precipitate



reward dysfunctions and result consequently in the emergence of anhedonic symptoms. However, further investigation is needed to disentangle the complex relationship linking reward processing to stress reactivity and cognitive processes in the etiology of MDD.

## **7.6 ACKNOWLEDGEMENTS**

We are very thankful to the University of Fribourg for enabling this research, to the MRI technicians at the Department of Diagnostic and Interventional Neuroradiology at the University Hospital of Bern, Switzerland, and to all the participants for making this study possible. We also thank Richard Reynolds for his precious suggestions and guidance during the preparation of the analyses.

## **7.7 FUNDING**

This work was supported by the Research Pool of the University of Fribourg, Fribourg, Switzerland [n°578] and by the Gottfried und Julia Bangerter-Rhyner-Stiftung [n°8472], Switzerland.

## **7.8 DECLARATION OF INTEREST**

None.



# CHAPTER 8

## ADDITIONAL DATA ANALYSES

---

## ADDITIONAL DATA ANALYSES

---

This chapter intends to explore additional data not presented in the three empirical works that are part of this PhD thesis. With the objective of monitoring the effectiveness of the experimental stress to induce increased reactivity of the biological stress system, the first aim of this chapter is to investigate how the unpredictable acute stress induced during the stress condition of the Fribourg reward task affected the activation of the HPA system monitored by measuring the salivary cortisol concentrations in healthy adults. The second aim of this chapter is to explore whether the HV showed a differential biological reactivity in response to the stress induction compared to the HC during the stress condition of the Fribourg reward task.

In the first section, we briefly cover the literature which investigated the effect of stress exposure on the reactivity of the HPA system using salivary cortisol measurements in healthy individuals. In the second section, we present the analyses carried over the salivary cortisol measurements collected during the Fribourg reward task in the healthy individuals who participated in *Empirical works I and II* to assess the effects of the experimental stressor on the reactivity of the HPA system. In the third section, we then describe the analyses carried over the salivary cortisol measurements collected during the Fribourg reward task in the HC and HV who participated in *Empirical works III* to examine whether both groups showed differential reactivity of the HPA system in response to the exposure to the experimental stressor.

## 8.1 BACKGROUND

In aversive and stressful situations, the biological stress response is an adaptive process for maintaining a state of homeostasis (McEwen, 1998). The stress response is characterized by heightened levels of arousal reflected by the physiological activation of the stress system that prepares the individual for dealing with the challenging context (C. W. Berridge, España, & Vittoz, 2010). The adaptive biological response to acute stress is twofold and comprises (i) an allostatic response leading to the activation of the sympathetic and HPA systems in order to respond to the stressor, and (ii) a self-controlling feedback system involving a negative feedback loop of the cortisol hormone arriving in the central nervous system (i.e. at the pituitary gland and hypothalamus) after the stressor has ceased in order to turn off the HPA system (Lovallo & Thomas, 2017; McEwen, 1998). When a threatening situation persists or when the stressor is not controllable, the self-controlling feedback system might get disrupted resulting in a sensitization of the stress system (van Oort et al., 2017). With the aim of understanding how these stress-related dysfunctions might develop, researchers explored the effects of sustained or unpredictable threats on both the biological reactivity of the stress system and the development of a state of anxiety and long-lasting worries (Bali & Jaggi, 2015; Schmitz & Grillon, 2012; Schmitz et al., 2011). One way to assess the reactivity of the biological stress system is to monitor the levels of salivary cortisol, a stress hormone released by the HPA system. So far, ample evidence described the common pattern of the cortisol reactivity in response to acute experimental stress exposure in laboratory settings (for a review see: Bali & Jaggi, 2015). Due notably to the delayed response of the salivary cortisol hormone, the literature documented mixed findings regarding the pattern of cortisol reactivity in response to acute stress exposure. Among healthy adults, the cortisol concentration was reported to peak after stressor onset with a delay ranging from 10 to 40 minutes (Dickerson & Kemeny, 2004; W. K. Goodman et al., 2017; Kudielka et al., 2009). Further, the cortisol concentration might return to initial pre-stressor level by 40-60 minutes after the stressor cessation (Dickerson & Kemeny, 2004). In sum, an adaptive response to stress exposure engages the HPA system and its end product the cortisol hormone (E. K. Adam et al., 2017). Ample evidence demonstrated HPA axis dysfunction in several mental disorders including MDD, anxiety disorders or schizophrenia (for a review see: Zorn et al., 2017). Of particular importance for this thesis, MDD has been associated with abnormalities of the HPA axis. However the effects of stress on the HPA system in MDD are not clear so far since the literature reported conflicting results. Some studies suggested increased cortisol concentration in MDD patients in daily life (for a review see: Frodl & O'Keane, 2013), while in contrast, other studies showed blunted basal cortisol concentration in MDD patients in daily life (Boggero et al., 2017; for a review see: Dedovic et al., 2005) and similar or even

blunted salivary cortisol concentration in experimental settings (for a review see: Handwerker, 2009). Altogether, these abnormalities might reflect the sensitization of the HPA system and constitute therefore a promising risk factor linking stress to depression (e.g. E. K. Adam et al., 2010; Belmaker & Agam, 2008).

To the best of our knowledge, only one study explored the HPA system reactivity to experimental stress exposure in individuals at increased risk for MDD (Dienes et al., 2013). This study suggested that cortisol levels in response to the experimental stressor didn't differ between healthy individuals with and without increased risk for MDD. Since little is known about the implication of the HPA system in response to acute experimental stressor in the vulnerability to MDD, the aim of the section 8.3 is to investigate whether the reactivity of the HPA system in response to the administration of an unpredictable acute stressor differed between healthy individuals without and with increased risk for MDD during the Fribourg reward task. Before turning to this question, we describe in the section 8.2 how healthy adults reacted to the induction of unpredictable acute stress during the Fribourg reward task in *Empirical work I*.

## 8.2 EFFECTS OF THE EXPERIMENTAL STRESSOR ON CORTISOL RESPONSES IN HEALTHY INDIVIDUALS (EMPIRICAL WORK I)

Based on extended literature that investigated the pattern of the cortisol reactivity in response to experimental stress among healthy adults (for meta-analyses see: W. K. Goodman et al., 2017; Kudielka et al., 2009), we explored whether the experimental stress administered during the stress condition of the Fribourg reward task increased the levels of free salivary cortisol. Specifically, we hypothesized a peak in free salivary cortisol response occurring about 20 to 40 minutes after the start of the stress condition, followed by a progressive decrease corresponding to the recovery phase after stressor cessation. The blue dashed line in Figure 8.1 illustrates the general pattern of the cortisol response expected in healthy adults in *Empirical work I*, with the continuous blue line showing the expected additional effect produced by the stressor. As described in Table 8.1, we failed to identify a clear activation of the HPA system in response to the experimental stress induced during the stress condition, as indicated by the absence of significant negative slope for the quadratic time effect,  $t_{(23)} = .67, p > .05$ . As illustrated in the panel B of Figure 8.1, the cortisol concentration varied considerably among participants, reflecting important inter-individual variations in the activation of the HPA system during the task. However, the cortisol concentration in some participants showed a clear rebound during the stress condition despite of the increased cortisol concentration at the start of the scanning session.

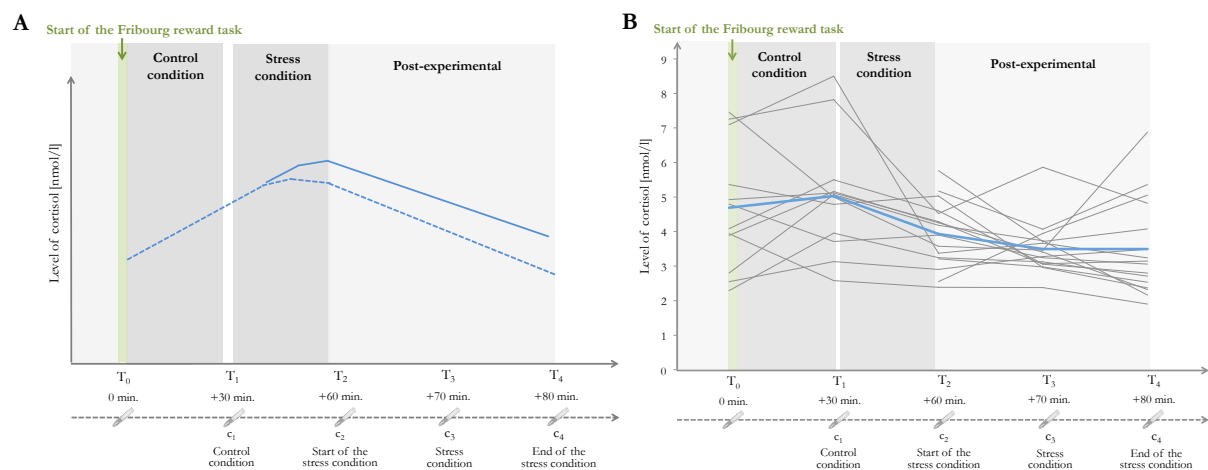

*Figure 8.1.* Illustration of (A) the hypothesis related to the evolution of the salivary cortisol concentration observed in 16 healthy adults, and (B) their salivary cortisol concentration during the Fribourg reward task. In panel A, the dashed blue line illustrates the general pattern of the cortisol response expected in healthy adults during the Fribourg reward task and the continuous blue line to the additional effect produced by the stressor. In panel B, the grey lines correspond to the cortisol concentration and the blue line to the mean of cortisol concentration among participants. Salivary cortisol samples were collected from each participant starting with the first saliva sampling at the entry in the scanner (T<sub>0</sub>), between the control condition and the stress condition (T<sub>1</sub>) namely the block 1 and block 2, directly by the end of the stress condition (T<sub>2</sub>), 10 min. (T<sub>3</sub>) and 20 min. (T<sub>4</sub>) after the end of the stress condition. As the cortisol level peaks around 20 to 40 min. after the stressor onset, the evolution of cortisol level (nmol/l) across time is represented on the graph by c<sub>1</sub>, c<sub>2</sub>, c<sub>3</sub> and c<sub>4</sub> with c<sub>1</sub> corresponding to the start of the control condition, c<sub>2</sub> to the start of the stress condition, c<sub>3</sub> to the middle of the stress condition, and c<sub>4</sub> to the end of the stress condition.

Taken together, this might point out to the possibility that the scanning session itself induced a physiological stress response in some participants, resulting in a possible bleeding effect of stress response produced by the scanning session over the effect induced by the stress condition. Furthermore, we tested whether the level of baseline cortisol (i.e. salivary sample collected at  $T_0$ ), gender or the time of the day when the task was performed were significantly associated with the linear and the quadratic slopes of cortisol measures. As described in Table 8.1, the baseline cortisol levels made significant contributions to predict the linear and quadratic slopes. The baseline cortisol level ( $T_0$ ) was associated with the linear and quadratic slopes of estimated cortisol levels, respectively  $B = -0.004$ ,  $SE = 0.001$ ,  $t_{(11)} = -3.36$ ,  $p < .05$  and  $B = 0.00008$ ,  $SE = 0.00002$ ,  $p < 0.01$ ,  $t_{(11)} = 3.56$ ,  $p < .01$ . The higher the baseline cortisol level ( $T_0$ ) in healthy adults, the faster the decline in their cortisol concentration during the Fribourg reward task. Moreover, our results suggest that cortisol levels didn't vary significantly during the Fribourg reward task in participants with low baseline cortisol concentration ( $T_0$ ), indicated by a flat reactivity curve. No significant random effect for the linear slope appeared, suggesting that the physiological reactivity to stress did not vary significantly across participants,  $\chi^2_{(11)} = 15.76$ ,  $p > .05$ . Due to limitations in statistical power, no random effect for the quadratic slope could be entered in the model. Further, the cortisol response was not influenced significantly by the gender or by the time of the day at which the experimental task was performed.



Table 8.1  
*Cortisol (log) response during the Fribourg reward task in 16 healthy adults*

	B coefficient	SE	df	t-ratio	p-value
Fixed effects					
Intercept, $\beta_{00}$	0.58605	0.05	11	11.61	< .001
Gender, $\beta_{01}$	0.11086	0.07	11	1.61	0.14
Day time, $\beta_{02}$	0.06269	0.07	11	0.90	0.39
Baseline cortisol, $\beta_{03}$	0.05434	0.02	11	2.94	0.01
Linear time slope, $\pi_1$					
Intercept, $\beta_{10}$	-0.00389	0.003	11	-1.19	0.26
Gender, $\beta_{11}$	0.00060	0.004	11	0.14	0.89
Day time, $\beta_{12}$	-0.00114	0.004	11	-0.26	0.80
Baseline cortisol, $\beta_{13}$	-0.00401	0.001	11	-3.36	0.01
Quadratic time slope, $\pi_2$					
Intercept, $\beta_{20}$	0.00004	0.0001	23	0.666	0.512
Gender, $\beta_{21}$	-0.00004	0.0001	23	-0.504	0.619
Day time, $\beta_{22}$	-0.00004	0.0001	23	-0.518	0.610
Baseline cortisol, $\beta_{23}$	0.00008	0.00002	23	3.582	0.002
	SD	Variance component	df	X <sup>2</sup>	p-value
Random effects					
Intercept, $r_{0i}$	0.08032	0.00645	11	22.903	0.018
Linear time slope, $r_{1i}$	0.00138	0.00000	11	15.761	0.150
Quadratic time slope, $r_{2i}$	-	-	-	-	-

*Note.* Table shows fixed effects with standard error (SE) for the linear time effect and quadratic time effect and random effects with standard deviation (SD) for the intercept and the linear time effects. On Level-2, the gender, day time, and baseline cortisol level were added as control variables. Time was coded in minutes ; the intercept represents T<sub>1</sub>. Cortisol (log) was measured in nmol/L. *df*, degree of freedom ; *t-ratio*, Test of Student; *X<sup>2</sup>*, chi square.

### 8.3 DIFFERENTIAL EFFECTS OF THE EXPERIMENTAL STRESSOR ON CORTISOL RESPONSES IN HEALTHY INDIVIDUALS WITHOUT AND WITH INCREASED FAMILIAL VULNERABILITY TO MAJOR DEPRESSION (EMPIRICAL WORK III)

Here, we investigated whether the HV showed a differential HPA system reactivity compared to the HC in response to the experimental stress induced during the stress condition of the Fribourg reward task. Specifically, we hypothesized that the HV and HC would differ in the amplitude of their stress response, with HV showing globally higher cortisol concentration, but smaller stress reactivity and slower recovery after stressor cessation. Figure 8.2 illustrates the pattern of the cortisol concentration that we hypothesized in HC with a blue ticked line and in HV with a red ticked line. The graphical analysis displayed in Figure 8.2 suggests a marked inter-individual variability in the cortisol concentration during the Fribourg reward task, in particular in HV. Moreover, the cortisol concentration at the start of the control condition ( $c_1$ ) were particularly elevated, probably due to the stress induced by the scanning session itself.

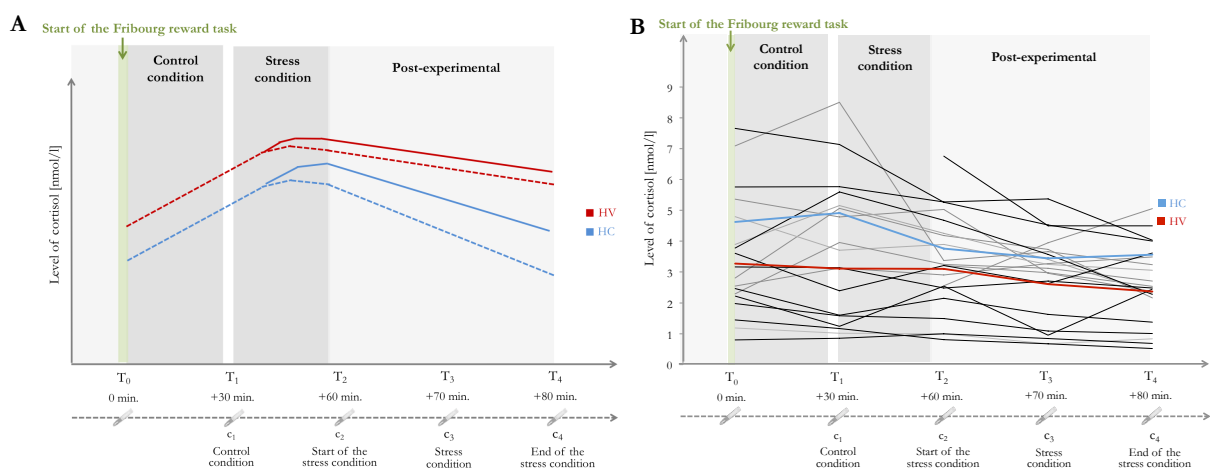

Figure 8.2. Illustration of (A) the hypothesis related to the evolution of the cortisol concentration observed in 10 healthy adults without (HC, healthy control) and 12 healthy adults with (HV, healthy vulnerable) increased risk for major depression, and (B) their cortisol concentration during the Fribourg reward task. In panel A, the dashed blue line illustrates the pattern of cortisol concentration expected in HC, while the dashed red line the pattern of the cortisol concentration expected in HV. The continuous blue line represents the additional effect produced by the stressor in HC, while the continuous red line corresponds to the additional effect produced by the stressor as expected in HV. In panel B, the grey lines correspond to the cortisol concentration in HC, the black lines to the the cortisol concentration in HV, the blue line to the mean of cortisol concentrations in HC, and the red line to the mean of cortisol concentration in HV. Salivary cortisol samples were collected from each participant starting with the first saliva sampling at the entry in the scanner ( $T_0$ ), between the control condition and the stress condition ( $T_1$ ) namely the block 1 and block 2, directly by the end of the stress condition ( $T_2$ ), 10 min. ( $T_3$ ) and 20 min. ( $T_4$ ) after the end of the stress condition. As the cortisol level peaks around 20 to 40 min. after the stressor onset, the evolution of cortisol level (nmol/l) across time is represented on the graph by  $c_1$ ,  $c_2$ ,  $c_3$  and  $c_4$  with  $c_1$  corresponding to the start of the control condition,  $c_2$  to the start of the stress condition,  $c_3$  to the middle of the stress condition, and  $c_4$  to the end of the stress condition.

As presented in Table 8.2, we failed to show a clear group effect on the stress response to the experimental stress induced during the stress condition, as indicated by the absence of significant group effect on the quadratic time effect,  $t_{(17)} = .37, p > .05$ . Irrespective of groups, there was a significant inter-individual variations in the cortisol levels at  $T_1$  (i.e. salivary sample collected between the control condition and the stress condition), demonstrating significant differences in cortisol level at the start of the control condition,  $t_{(17)} = 6.06, p < .001$ . As previously, this might point out to the stress-induced effect by the scanning session itself in some participants, resulting in a loss of effect produced by the stress induction afterwards. We also tested whether the level of baseline cortisol (i.e. salivary sample collected at  $T_0$ ), gender, or the time of the day when the task was performed were significantly associated with the the linear and the quadratic slopes of cortisol measurements. Baseline cortisol levels contributed significantly to predict the linear slope in both groups. Specifically, the levels of baseline cortisol ( $T_0$ ) were significantly and negatively associated with the linear slope of estimated cortisol levels in the HV and HC,  $B = -0.0024, SE = 0.001, t_{(17)} = -2.186, p < 0.05$ . The higher the baseline cortisol level ( $T_0$ ) in HV and HC, the faster the decline in their cortisol concentration during the Fribourg reward task. Our data suggest that cortisol levels didn't vary significantly during the Fribourg reward task in participants with low baseline cortisol concentration ( $T_0$ ), whose reactivity might be characterized by a flat reactivity curve. Also, there was considerable variation in the linear slope of the cortisol response in the HV and HC, suggesting that the cortisol concentration varied significantly over the task across participants,  $\chi^2_{(17)} 29.38, p < .05$ . Due to the lack of statistical power, no random effect for the quadratic slope could be entered in the model. Further, the cortisol response during the task was not influenced significantly by the group, the gender or the time of the day during which the task was performed.

Table 8.2

Comparison of the cortisol (log) response during the Fribourg reward task in 10 healthy control (HC) and 12 healthy vulnerable (HV) adults

	B coefficient	SE	df	t-ratio	p-value
Fixed effects					
Intercept, $\beta_{00}$	0.576365	0.095073	17	6.062	< .001
Group, $\beta_{01}$	-0.138980	0.099127	17	-1.402	.179
Gender, $\beta_{02}$	-0.029813	0.102723	17	-0.290	.775
Day time, $\beta_{03}$	0.042595	0.100211	17	0.425	.676
Baseline cortisol, $\beta_{04}$	0.103858	0.025197	17	4.122	< .001
Linear time slope, $\pi_1$					
Intercept, $\beta_{10}$	-0.002645	0.004179	17	-0.633	.535
Group, $\beta_{11}$	0.001657	0.004432	17	0.374	.713
Gender, $\beta_{12}$	-0.004699	0.004510	17	-1.042	.312
Day time, $\beta_{13}$	0.003389	0.004415	17	0.768	.453
Baseline cortisol, $\beta_{14}$	-0.002405	0.001100	17	-2.186	.043
Quadratic time slope, $\pi_2$					
Intercept, $\beta_{20}$	0.000024	0.000080	36	0.293	.772
Group, $\beta_{21}$	-0.000014	0.000087	36	-0.160	.874
Gender, $\beta_{22}$	0.000088	0.000087	36	1.010	.319
Day time, $\beta_{23}$	-0.000145	0.000085	36	-1.708	.096
Baseline cortisol, $\beta_{24}$	0.000044	0.000021	36	2.029	.050
	SD	Variance component	df	X <sup>2</sup>	p-value
Random effects					
Intercept, $r_{0i}$	0.18567	0.03447	17	79.80520	< .001
Linear time slope, $r_{1i}$	0.00221	0.00000	17	29.38083	0.031
Quadratic time slope, $r_{2i}$	-	-	-	-	-

*Note.* Table shows fixed effects with standard error (SE) for the linear time effect and quadratic time effect and random effects with standard deviation (SD) for the intercept and the linear time effects. On Level-2, the group was added as predictor, while the gender, day time and baseline cortisol level were added as control variables. Time was coded in minutes ; the intercept represents T<sub>1</sub>. Cortisol (log) was measured in nmol/L. *df*, degree of freedom ; *t-ratio*, Test of Student; *X*<sup>2</sup>, chi square.

# CHAPTER 9

## GENERAL DISCUSSION

---

# GENERAL DISCUSSION

---

The purpose of the present thesis was to examine how the normal function of reward processing is affected by stress exposure, cognitive load, and emotion regulation, and how the interaction between these factors and the reward processing might inform us about the vulnerability to major depression. To answer these questions, the **first aim** of this thesis was to investigate how stress exposure influences the basic neural mechanisms of reward processing in healthy adults, with the scope of yielding new insights on the vulnerability factors involved in the development of stress-related psychopathologies. The **second aim** of this thesis was to explore how cognitive resources at disposal, manipulated by variable levels of cognitive load, may contribute to modulate the effect of stress exposure on the basic mechanisms of reward processing in healthy adults. Given that anhedonia has been associated with an impaired ability to experience positive and hedonic emotions along with difficulties in emotion regulation, the **third aim** of this thesis was to examine whether the propensity of healthy adults to use adaptive or maladaptive emotion regulation strategies is associated with (i) the neural responsiveness to reward delivery, a measure of hedonic responsiveness to reward. Specifically, the inability to experience hedonic feelings from positive stimuli and the difficulty to engage in motivated behaviors are core symptoms of MDD. In this framework, we also tested whether both (i) the neural responsiveness to reward delivery, as well as (ii) the use of adaptive and maladaptive emotion regulation strategies are linked to the severity and intensity of subclinical depressive symptoms in healthy individuals.

Finally, the **fourth aim** of this thesis was to use the vulnerability to depression as a clinical model to test the implications of stress exposure on the reward processing as risk factor for the development of anhedonic symptoms. Specifically, we investigated whether the effect of stress exposure on reward processing might differentiate between HV and HC. In an exploratory way, we also examined whether variable levels of cognitive load modulate the effect of stress exposure on reward processing in a way that distinguishes HC from HV.

In the following sections, we summarize first the key findings of each empirical work in regard to our initial aims. Further, we discuss these findings in the light of the literature to yield potential new insights on the mechanisms at play and their clinical implications for the vulnerability to major depression. Finally, we outline the limitations and methodological considerations regarding the empirical works embedded in this thesis, as well as challenges and new avenues.

## 9.1 SUMMARY OF FINDINGS

With the aim of helping elucidate the influencing factors involved in the disruption of the reward processing and their clinical implications for the vulnerability to major depression, we collected fMRI and behavioral measurements cross-sectionally in healthy adults, including HC and HV. Furthermore, we explored the associations between fMRI measurements and (i) the self-reported tendency to use adaptive and maladaptive emotion regulation strategies, and (ii) the intensity and severity of subclinical depressive symptoms. *Empirical work I* investigated how stress exposure affects the basic mechanisms of reward processing in healthy adults, and how variable levels of cognitive load modulate the effects of this stress exposure on reward processing. *Empirical work II* tested whether the propensity of healthy adults to use adaptive or maladaptive emotion regulation strategies is associated with the striatal responsiveness to reward delivery. *Empirical work III* examined whether the effect of stress exposure on reward processing might discriminate HC from HV, and whether variable levels of cognitive load modulate the effect of stress exposure on reward processing in a different way among both groups.

### 9.1.1 Effect of stress exposure on reward processing in healthy adults, and the modulatory role of cognitive load

In our first empirical work, we used an event-related fMRI task to examine how an unpredictable acute stressor (threat-of-shock) affects reward responsiveness in healthy adults, and how variable levels of cognitive effort (WM load) to exert for obtaining a monetary reward modulate stress-induced effects on reward responsiveness. To the best of our knowledge, this is one of the first studies exploring specifically the additional influence of WM load on stress-induced effects on the neural reactivity to reward during the anticipatory and delivery phases. Based on previous research in animals (for a review see: Cabib & Puglisi-Allegra, 2012) and in humans (for a review see: Cabib & Puglisi-Allegra, 2012; J. M. Choi et al., 2014; Kumar et al., 2014; Lewis et al., 2014; Porcelli et al., 2012), we hypothesized that threat-of-shock would increase striatal reactivity to cued reward during anticipation, and would reduce striatal reactivity to reward notification during feedback delivery. In addition, we expected that high WM load would hinder the enhancing effect of stress on striatal reactivity to reward anticipation, but would reinforce the blunting effect of stress on the striatal reactivity in response to reward notification. At the behavioral level, we postulated that both threat-of-shock and higher cognitive load would decrease performance (as reflected by a slower reaction time and a decreased response accuracy), thus acting synergistically. In line with previous studies (Bogdan & Pizzagalli, 2006; Grillon et al., 1993), threat-of-shock

successfully induced negative mood and increased self-reported stress in participants. During reward anticipation, reward cues enhanced ventral and dorsal reactivity, irrespective of stress exposure and cognitive effort to exert for getting the reward. Accordingly, behavioral data demonstrated an enhancing effect of reward on performance, as indicated by more accurate responses. During feedback notification, both stress and cognitive effort influenced striatal activation, but these factors did not interact to modulate reward responsiveness. Stress heightened the reactivity of the dorsal striatum and enhanced cognitive performance. Additionally, striatal reactivity to reward notification during delivery was modulated by the level of WM effort exerted to obtain the reward, with significantly decreased responsiveness to reward delivery in the ventral striatum following high, compared to low, cognitive effort. Contrary to our expectations, neither significant interaction occurred between stress exposure and reward processing during the anticipation and delivery phases, nor cognitive load modulated the effect of stress on reward processing.

In the additional data analyses, we assessed the reactivity of the biological stress system by monitoring the levels of salivary cortisol during the Fribourg reward task, a stress hormone released by the HPA system. These analyses failed to evidence a clear effect of the experimental stressor on the biological stress system in both HC and HV, as evidenced by the absence of significant increase in the salivary cortisol concentration in response to the experimental stress exposure. Also, these additional data analyses didn't identify any group difference between the HC and HV in the reactivity of their biological stress system during the Fribourg reward task. Our data suggest that the level of salivary cortisol before entering the scanner was associated with the speed of recovery during the Fribourg reward task in both HC and HV. Specifically, subjects with higher cortisol levels before entering the scanner showed faster decrease in their salivary cortisol concentration during the Fribourg reward task. Also, our data suggest that some individuals showed a marked biological stress reactivity before entering the scanner, possibly due to the anticipation of the stress condition and of the scanning session itself. In contrast, some participants might have shown no significant reactivity before and during the Fribourg reward task. In sum, we couldn't evidence a significant additional effect of stress induction on the reactivity of the biological stress system. However, the experimental stress induction elicited a significant increase in the subjective feeling of being stressed and a significant decrease of mood levels in our healthy participants.



### **9.1.2 Relationship between the emotion regulation and the responsiveness to reward delivery in healthy adults, and their link to depressive symptoms**

In our second empirical work, we explored the association between the individuals' self-reported propensity to use adaptive and maladaptive emotion regulation strategies, and the striatal responsiveness to reward delivery, with a particular focus on the NAcc. Additionally, we investigated how the NAcc reactivity to reward delivery, as well as adaptive and maladaptive emotion regulation strategies correlate with the severity and intensity of subclinical depressive symptoms. First, we hypothesized that the tendency of healthy adults to use (i) adaptive emotion regulation strategies would correlate with increased NAcc responsivity to reward delivery, whereas (ii) maladaptive emotion regulation strategies would be related to decreased NAcc responsiveness to reward delivery. Second, we postulated that the intensity and severity of subclinical depressive symptoms in healthy adults would correlate negatively with both (iii) increased NAcc responsiveness to the reward delivery, and (iv) increased propensity to use adaptive emotion regulation strategies. In contrast, we expected that subclinical depressive symptoms reported by healthy adults would be positively associated with (v) higher tendency to use maladaptive emotion regulation strategies. In line with our hypotheses, our results demonstrated that the NAcc responsiveness to reward delivery was negatively associated with maladaptive emotion regulation strategies, suggesting that reduced NAcc responsivity to reward delivery might go along with the propensity to use more ineffective emotion regulation strategies. Also, as postulated, NAcc reactivity to reward delivery correlated with the severity and intensity of the subclinical depressive symptoms reported by healthy adults. Stronger self-reported depressive symptoms were associated with reduced NAcc responsiveness to reward delivery, indicating that decreased NAcc responsiveness to reward receipt might be linked to increased vulnerability to the development of anhedonic symptoms. Therefore, these findings suggest that maladaptive emotion regulation strategies might constitute a crucial factor implicated in the impaired ability to experience hedonic feelings and to encode reward value, resulting possibly in anhedonic symptoms. The interaction between reduced NAcc responsiveness to reward and the propensity to privilege maladaptive strategies to regulate emotional experiences might therefore precipitate anhedonia, a core symptom characterizing major depression.

### **9.1.3 Differential effects of stress exposure on reward processing between healthy control and healthy vulnerable individuals, and the modulatory role of cognitive load**

In our third empirical work, we explored whether the effect of stress exposure affects differentially the striatal responsiveness to rewards in HV compared to HC during the anticipation and delivery phases. Moreover we investigated, in an exploratory way, whether the cognitive effort modulates differentially the effect of stress exposure on the striatal reactivity to rewards in HV compared to HC. Based on prior findings in animals (e.g. Cabib & Puglisi-Allegra, 2012) and in humans (Kumar et al., 2014; Lewis et al., 2014; Porcelli et al., 2012), we expected that in HC, (i) stress exposure would intensify striatal reactivity to reward cues during anticipation, and would reduce striatal responsiveness to reward delivery. In contrast, we hypothesized that in HV, (ii) stress exposure would impair striatal reactivity to monetary reward during both the anticipation and delivery of rewards. At the behavioral level, we postulated that (iii) reward cues would improve WM performance, reflected by increased response accuracy and faster reaction times, with higher enhancing effect of reward cues in HC compared to HV. Also, we assumed that (iv) stress exposure would hinder the enhancing effect of reward cues on WM performance, indicated by decreased response accuracy and slower reaction times, with stronger stress-induced effect in HV. In line with our expectations, stress induction instigated successfully higher self-reported negative mood in participants (Bogdan & Pizzagalli, 2006; Grillon & Ameli, 1998; Torrisi et al., 2016), while rewarded trials heightened significantly self-reported positive mood and behavioral performance. During the anticipation phase, stress reduced the ventral striatal responses in HV, regardless of reinforcement schedule. This effect was modulated by cognitive load, with significant stress-induced impairment in the low, compared to high, cognitive load condition. Additionally, HV showed a significant reduction in the caudate nucleus activation in all conditions during anticipation in comparison with HC. Interestingly, stress exposure increased the putamen reactivity to reward cues in both groups, whereas we had postulated that it would only occur in HC. These results were supported by an enhancing effect of stress on performance in both groups, as reflected by higher response accuracy and faster reaction times. Moreover, both groups demonstrated significant reactivity to reward cues in the ventral and dorsal striatum during reward anticipation. Increased striatal responsiveness to reward cues coincided with enhanced performance, as indicated by increased response accuracy in rewarded trials in both groups.

During the delivery phase, HV showed reduced NAcc activation after the exertion of higher cognitive effort, suggesting an adverse effect of cognitive effort on NAcc reactivity during the delivery phase. In both groups, stress heightened the dorsal striatal responses, irrespective of reinforcement schedule and cognitive load. Unexpectedly, the groups didn't differ, nor did stress

affect them differentially, in their striatal responsiveness to reward cues and to reward delivery. Also, the groups did not differ in reaction times and response accuracy as a function of reinforcement, stress exposure or cognitive load. Taken together, these findings suggest that stress exposure might have a detrimental effect on the ability of HV to evaluate the incentive value of reward cues, in particular under stress exposure and when less cognitive demands are at stake. Further, reduced caudate activation in HV might constitute a marker of increased risk for the development of anhedonic symptoms, such as increased difficulty to encode reward value, to engage and to maintain motivated behaviors oriented to pleasurable activities.

## **9.2 INTEGRATED DISCUSSION OF FINDINGS**

Here after, the key findings of each empirical work are integrated in the light of the current literature with the aim of providing new insights on the basic mechanisms at the interplay between stress and reward processes, and on how higher-order cognitive functions might modulate stress-induced effects on the ability to engage in approach behaviors and to experience hedonic responses. Further, the clinical implications of these mechanisms for the vulnerability to depression are outlined.

### **9.2.1 Effect of stress exposure on striatal reactivity : insights on potential vulnerability markers for the development of compulsive automatized behaviors**

The first aim of this thesis was to explore how stress exposure influences the basic mechanisms of reward processing in healthy adults. In this framework, the first and third empirical works involved the manipulation of an unpredictable acute stressor known to induce a state of anxiety marked by prolonged apprehension and negative emotions (Davis et al., 2010; O. J. Robinson, Bond, & Roiser, 2015), while assessing in parallel striatal reactivity to reward anticipation and reward delivery. Here after, we discuss two major effects induced by stress exposure on the striatal reactivity.

#### **9.2.1.1 Stress-induced heightened arousal in the dorsal striatum**

In healthy adults including both HC and HV, stress exposure strengthened the activation of the dorsal striatum (i.e. bilateral caudate nucleus), irrespective of reinforcement schedule and cognitive effort exerted (see Table 5.1 and Table 7.2). Specifically, increased stress-related recruitment of the dorsal striatum might be due to heightened arousal mediated by increased DA release in the dorsal striatum, projected mostly from the SNc (Hassan & Benarroch, 2015; Schultz, 2016). Previous research evidenced the effect of physiological stressor on increased DAergic activity in the dorsal striatum (for a review see: Vaessen, Hernaus, Myin-Germeys, & van Amelsvoort, 2015). Phasic DAergic activity in the dorsal striatum has been related to the encoding of motivational salience of incentives (Hassan & Benarroch, 2015; Schultz, 2016), but also to sensorimotor coordination, motor preparation, efficient planning, and initiation of goal-driven behaviors (Gepshtein et al., 2014; Kogler et al., 2015; Robbins & Everitt, 1992). It was suggested that the caudate nucleus subserves mainly the selection of appropriate action schemas based on the evaluation of action-outcome associations (Grahn et al., 2008).

This stress-induced activation in the dorsal striatum in all conditions was associated with

enhanced cognitive performance. Together, this might reflect heightened cognitive and emotional arousal along with stronger sensory processing under stress exposure (Ernst, Lago, Davis, & Grillon, 2016; O. J. Robinson et al., 2013). In line with this hypothesis and other data (for a review see: Dedovic et al., 2009; see also: Henckens, Hermans, Pu, Joëls, & Fernández, 2009), stress exposure elicited increased engagement of the occipital and middle temporal regions during the anticipation phase (see Table 7.3), thus supporting the idea of stress-induced cognitive arousal and hypervigilance as indicated by increased engagement of brain regions involved in visual and memory processing during cue presentation. Additionally, our results evidenced stronger recruitment of superior frontal regions during stress exposure (see Table 5.2 and Table 7.3), suggesting enhanced cognitive arousal mediated possibly by increased DA release from the SNc to prefrontal regions, in particular to the dlPFC. This is directly in accordance with data showing that unpredictable acute stress results in increased DA release in the PFC leading possibly to higher WM performance (Arnsten & Jin, 2014; Weerda et al., 2010). Therefore, these findings might support the idea that under certain conditions, higher stress-induced arousal mainly mediated by the projection of DA from the SNc to the dlPFC and to the dorsal striatum might facilitate cognitive processes (for a review see: Schwabe et al., 2010) and promote adaptive coping with the stressor in the very short term (van Oort et al., 2017). Nevertheless, interpretations on the potential involvement of the DA system should be considered with caution since our study did not manipulate DA pharmacologically.

Contrary to our findings, a number of human studies evidenced also a detrimental effect of acute stress exposure on higher-order cognitive functions such as WM performance (Luethi, 2008; Qin et al., 2009; Schoofs et al., 2008) or selective attention (Henckens, van Wingen, Joëls, & Fernández, 2012). In line with these conflicting results, the biphasic-reciprocal model of reallocation of neural resources in response to stress (Hermans et al., 2014) stipulates that the exposure to acute stress provokes a reallocation of neural resources to brain regions involved in fear processing and vigilance at the expense of the executive control network implicated in higher-order processes. With the aim of reconciling the inconsistencies, the biphasic-reciprocal model of reallocation of neural resources in response to stress suggested that acute stress exposure might exert differential effect on higher-order cognitive functions and their neural correlates over time (Hermans et al., 2014). Thus, the effect of acute stress exposure might be characterized by an inverted U-shaped curve, according to which stress will impair cognitive functions directly after stressor onset, but will improve cognitive functions progressively, and then alter them again over sustained exposure to the stressor (Mendl, 1999; van Oort et al., 2017). In sum, this hypothesis opens interesting avenues to further clarify the critical factors implicated in the modulation of the

effects induced by acute stress exposure on higher-order cognitive functions.

### **9.2.1.2 Stress-induced sensitization of reward reactivity in the dorsal striatum**

In our third empirical work, we evidenced that stress exposure induced stronger putamen recruitment in response to cues predicting rewards compared to cues predicting the absence of rewards, in both HC and HV. These results are in line with previous studies in animals (for a review see: Ungless et al., 2010) and in humans (Kumar et al., 2014; Pool et al., 2015) which demonstrated that acute stress exposure amplified motivation and effort mobilized to obtain predicted rewards. Our results are also in accordance with the incentive salience theory which posits that the motivational component and the affective component of reward processing are distinct and that they can be engaged independently from each other depending upon the circumstances (K. C. Berridge & Robinson, 1998). Of particular importance, our results showed that the strengthened reward-related motivation reflected by increased putamen reactivity to reward cues under stress exposure along with enhanced performance were not associated with hedonic responsiveness during reward delivery. Therefore, a hypothesis is that stress might sensitize the mesolimbic DA system implicated in the motivational component of reward processing, by invigorating motivation and reward-seeking behaviors.

Our results suggest that stress exposure might also affect reward learning processes. In the framework of learning theories, action selection and motivated behaviors are controlled by at least two competing systems that rely on different strategies for guiding behaviors (Lee, Shimojo, & O'Doherty, 2014). The first reinforcement learning process, also called model-based learning, evaluates the contingencies between an instrumental action and its outcome (e.g. a positive reinforcer or a reward) and computes the value of actions in order to build an internal model of the environment (Balleine & Dickinson, 1998; Daw, Niv, & Dayan, 2005). While early reinforcement learning is usually initiated by instrumental conditioning through model-based learning, goal-directed behaviors progressively become more habitual and automatized (Everitt & Robbins, 2013). This second reinforcement learning process is described as model-free learning and is anchored in a stimulus-response mechanism. In the model-free learning, the experience is used directly in the form of a reward prediction error that signals the difference between actual and predicted rewards (Schultz et al., 1997). The positive reinforcer enhances the association between the outcome and the stimulus paired with reinforcement (Everitt & Robbins, 2013). Therefore, a determinant function of DA in the model-free learning process is to link reward value to the cues that predict rewards (Baskin-Sommers & Foti, 2015). These two reinforcement learning processes may implicate different neural substrates, with goal-directed behaviors governed mainly by the

NAcc core and dorsomedial striatum (i.e. caudate nucleus in primates) and the dorsolateral striatum (i.e. putamen in primates) involved in the control of habits (Burton, Nakamura, & Roesch, 2015). Specifically, the putamen plays a critical role in the planning and implementation of actions, as well as in habit formation (Everitt & Robbins, 2013; Grahn et al., 2008; Schwabe et al., 2010). From the perspective of learning theories, our results suggest that acute unpredictable stress might induce a shift from voluntary controlled goal-driven behaviors (model-based learning) to more automatized behaviors (model-free learning), as reflected by stronger recruitment of the putamen in response to reward cues.

Taken together, the present findings indicate that unpredictable acute stress might sensitize incentive motivation by (i) increasing the recruitment of the dorsal striatum to outcomes generally, (ii) amplifying putamen reactivity to reward cues during the anticipatory phase, and (iii) enhancing arousal resulting in increased cognitive performance. This is in line with findings evidencing that increased mesolimbic DA release during stress exposure fosters behavioral activation and active coping in animals (Cabib & Puglisi-Allegra, 2012). It is also consistent with the association linking stronger recruitment of the dorsal striatum to the development of compulsive behaviors, as reflected by the relationship between the engagement of the dorsal striatum and the intensity of their compulsive drug-seeking behaviors in patients suffering from addiction (for a review see: Everitt & Robbins, 2013). At the neurobiological level, the transition from voluntary controlled behaviors to compulsive drug-seeking behaviors has been associated with a progression in the locus of control over behaviors from the ventral to the dorsal striatum together with increased salience detection and impaired prefrontal inhibitory control mechanisms (Baskin-Sommers & Foti, 2015; Everitt et al., 2008; Everitt & Robbins, 2005, 2013). Therefore, this shift from ventral to dorsal striatum is thought to underpin the development of compulsive behaviors in the form of habits that are characterized by a loss of control (George & Koob, 2010). In the light of this neurobiological hypothesis and of animal data, our findings suggest that stress exposure results in (i) an increased arousal mirrored by stronger activation of the dorsal striatum in response to outcomes generally and by quicker reaction times, and (ii) strengthened reward-seeking motivation indicated by enhanced putamen reactivity to reward cues. In sum, exposure to acute unpredictable stress might shift the locus of control from the ventral to the dorsal striatum, promoting behavioral activation, more automatized actions, and active coping strategies. While this process might be adaptive in the short term for dealing with the stressor, it may become problematic in the long run by increasing the probability of developing compulsive or risk-taking behaviors.

From the perspective of learning theories, the increased activation in the dorsal striatum in

response to outcomes generally and enhanced putamen reactivity to reward cues that occurred in our results suggest that acute unpredictable stress exposure contributes to a shift from model-based to model-free learning processes. This shift might constitute a vulnerability marker for the emergence of maladaptive behaviors, possibly due to reduced cognitive control over the stressor, increased arousal, and insensitivity to reward devaluation. This is in accordance with a wealth of studies demonstrating that the mPFC and the hippocampus play a central inhibitory role over stress reactivity by down-regulating stress-responsive limbic (i.e. amygdala) and brainstem regions (for a review see: S. U. Maier, Makwana, & Hare, 2015). For instance, individuals with stronger cognitive functions would be better equipped in the face of stress exposure, with higher WM capacity protecting model-based learning from stress (Otto, Raio, Chiang, Phelps, & Daw, 2013). Interestingly, the control over a stressor through the recruitment of the mPFC might foster the ability of the mPFC to cope successfully with subsequent uncontrollable stressors, promoting therefore resilience to stress exposure (S. F. Maier, Amat, Baratta, Paul, & Watkins, 2006; S. U. Maier et al., 2015). Taken together, the existing literature indicates that higher-order cognitive functions might constitute a protective factor in the regulation and maintenance of functional reward responding under stress exposure, promoting therefore adaptive motivated behaviors and learning processes. In this framework, the next section discusses our main results relating to the modulatory effect played by cognitive load in the reward responsiveness.

### **9.2.2 Impaired reward responsiveness following higher cognitive effort**

The second aim of this thesis was to investigate how cognitive effort manipulated by variable levels of cognitive load might contribute to modulate the effects of stress exposure on reward processing in healthy adults. Although no three-way interaction effect (stress  $\times$  reward  $\times$  load) was observed in HC and in HV, the level of cognitive effort exerted in the task influenced the NAcc responsiveness to reward delivery. A large amount of findings in animals (Cromwell & Schultz, 2003; Fiallos et al., 2017; Hassani, Cromwell, & Schultz, 2001; Schoenbaum & Setlow, 2003; Webber, Mankin, & Cromwell, 2016) and in humans (for reviews see: Bartra et al., 2013; Diekhof et al., 2012; Xun Liu et al., 2011) documented the critical role played by the NAcc in encoding the valence of stimuli, and in reward prediction error. Of particular importance, the influential works of Schultz and colleagues in non-human primates evidenced that after monkeys have learned to associate a given stimulus with the delivery of a rewarding outcome (stimulus-outcome association) indicated by firing of DA neurons, this DA signal is transmitted back to the anticipatory phase with DA neurons firing in response to reward cues (Schultz, 1998).



Converging with animal studies, neuroimaging data in humans showed a similar transition of the NAcc activation from reward delivery to reward cues following the stimulus-response associative learning (e.g. O'Doherty et al., 2004). This suggests that the role of the NAcc in encoding reward value, and in reward learning during the reward notification, is consequently involved in the emergence of motivated behaviors during the anticipation phase.

In accordance with previous data (e.g. Botvinick, Huffstetler, et al., 2009), our results indicate reduced NAcc responsiveness to reward delivery after having exerted higher, compared to lower, cognitive effort. Research documented extensively the effort-discounting effect produced by higher physical or cognitive efforts on subsequent motivated behaviors in animals (e.g. Croxson et al., 2009; Walton et al., 2006) and in humans (e.g. Botvinick, Niv, & Barto, 2009; Krigolson et al., 2015; Stoppel et al., 2011). Therefore, our findings suggest that cognitive effort exerted previously modulates the value attributed to rewards during their notification, as mirrored by reduced NAcc responsiveness following higher cognitive effort. However, this discounting-effect produced by cognitive load on NAcc responsiveness might be specific to the situations in which extrinsic rewards are at stake. For instance, a study demonstrated that the NAcc responded more strongly to correct than incorrect responses during feedback delivery in absence of other extrinsic reinforcements, and that the magnitude of NAcc activation scaled upon the degree of WM effort engaged in the task (Satterthwaite et al., 2012).

In sum, our results reveal that the NAcc might have failed to encode the reward value when the instrumental performance required higher WM effort. Since the NAcc is known to subserve instrumental behaviors driven by specific goals (Robbins & Everitt, 1992; Vaessen et al., 2015), cognitive effort may reduce cognitive resources devoted to action-outcome association learning and to reward valuation, resulting consequently in decreased motivated behaviors driven by valued goals. In line with our hypothesis that higher cognitive resources might promote the adaptive reward processing, the next section discusses the determinant role played by the individual's propensity to use maladaptive emotion regulation strategies in the diminished NAcc responsiveness to reward delivery.

### 9.2.3 Implications of maladaptive emotion regulation in hedonic responsiveness

Given the importance of cognitive regulatory processes for the adaptive reward function, the third question targeted in the present thesis was how adaptive and maladaptive emotion regulation strategies are associated with the ability to experience hedonic responses in healthy adults. Emotion regulation constitutes a fundamental capacity to influence, consciously or not, emotional experience (Gross & Jazaieri, 2014; Naragon-Gainey et al., 2017). Therefore, the aim of our second empirical work was to explore how adaptive and maladaptive emotion regulation strategies are linked to the striatal responsiveness during the reward delivery in healthy adults, with a particular focus on the NAcc. The individual's propensity to use maladaptive emotion regulation strategies was associated with reduced NAcc responsivity to reward notification, suggesting that emotion regulation processes play a determinant role in hedonic experiences. In other words, maladaptive emotion regulation might impair the processing of positive emotions, specifically the reactivity to positive hedonic stimuli. Further, diminished NAcc responsiveness associated with maladaptive emotion regulation might also engender decreased model-based learning processes. While positive emotions are determinant for promoting approach behaviors toward advantageous resources, maladaptive emotion regulation strategies may impair the NAcc ability to encode reward value, resulting in reduced or ineffective goal-directed behaviors. Of particular importance, previous research indicated that the NAcc was implicated in emotion regulation processes by fostering the maintenance of positive emotions in healthy adults (Kim & Hamann, 2007; Morawetz, Bode, Derntl, & Heekeren, 2017). Further investigation is needed to clarify the nature of the relationship linking cognitive emotion regulation to hedonic responsiveness, and consequently to motivated behaviors. A hypothesis emerging from our results is that maladaptive emotion regulation strategies might mirror impaired higher-order executive functions associated with reduced top-down regulation from prefrontal regions (i.e. mPFC and dlPFC) over limbic regions (i.e. striatum, amygdala). These findings expand the existing literature on the interplay between reward processing and emotion regulation. However, additional studies are needed to identify the underlying mechanisms at play in the relationship linking hedonic responsiveness to emotion regulation. Here after, Figure 9.1 integrates our results in the light of the current literature and illustrates the reward-related mechanisms proposed in this thesis being implicated under unpredictable acute stress during the anticipation and delivery phases, and how cognitive regulatory resources at disposal, manipulated by varying levels of cognitive demands, as well as cognitive emotion regulation further modulate reward responsiveness.

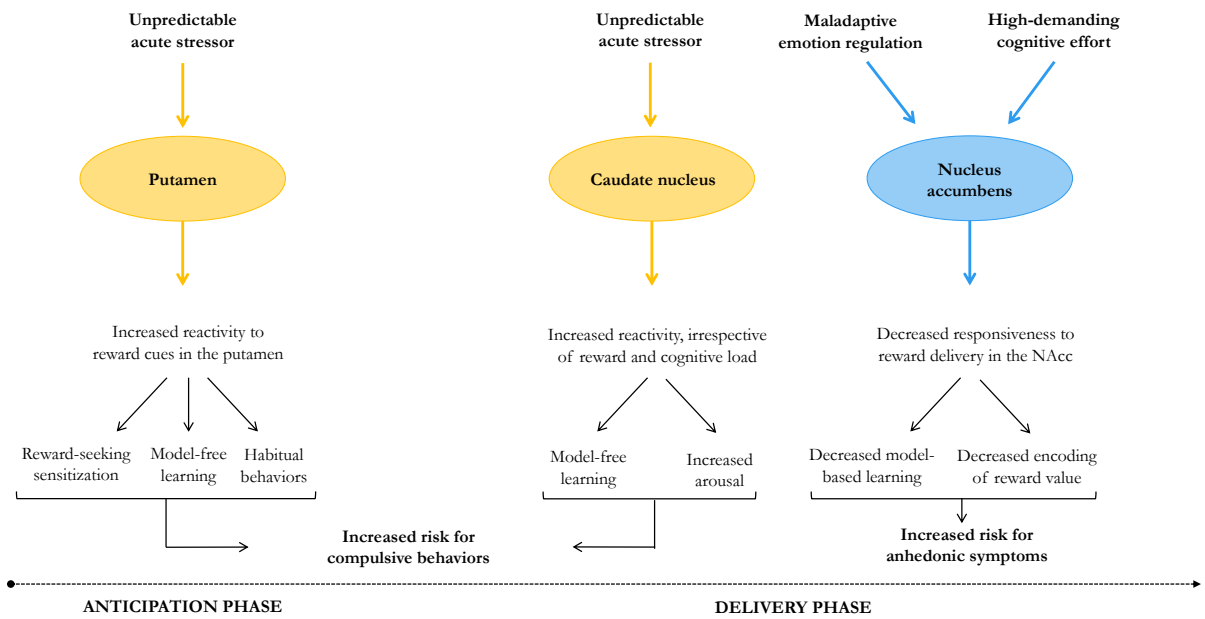

*Figure 9.1.* Illustration of the reward-related mechanisms proposed in this thesis being involved under unpredictable acute stress exposure during the anticipation and delivery phases in healthy adults, and how cognitive demands and cognitive emotion regulation strategies further modulate reward responsiveness during the delivery phase. During the anticipation phase, stress exposure induced increased reactivity in the bilateral putamen in response to cues predicting rewards, which might possibly result in heightened reward-seeking behaviors along with a transition from voluntary to more automatized behaviors. During the delivery phase, stress exposure strengthened the activation in the bilateral caudate nucleus. Heightened dorsal striatal recruitment may elicit increased arousal and may foster stimulus-outcome contingency learning, reinforcing therefore model-free learning and risk for the emergence of compulsive behaviors. Also, the nucleus accumbens responsiveness to reward delivery was reduced after the exertion of cognitively more demanding effort, which might lead potentially to decreased ability to encode reward value and further to diminished action-outcome association learning. Maladaptive emotion regulation strategies was negatively correlated with the nucleus accumbens responsiveness to reward delivery, which may contribute to increased risk for the emergence of anhedonic symptoms through the reduced ability to encode reward value.

#### **9.2.4 Insights on potential vulnerability markers in vulnerable individuals for major depression**

Last but not least, the fourth aim of the present thesis was to explore how the interaction between stress exposure and reward processing might contribute to provide new insights on the mechanisms underlying the vulnerability to major depression. Abnormalities in reward processing (Admon & Pizzagalli, 2015a; Hägele et al., 2015; Hasler et al., 2004; Luking et al., 2016; Martin-Soelch, 2009; Nelson et al., 2018) and increased stress sensitivity (e.g., Anisman & Matheson, 2005; Dienes et al., 2013; Goodyer et al., 2009; Hasler et al., 2004; Hasler & Northoff, 2011; Keller et al., 2007) have been extensively evidenced in major depression. In this framework, we investigated in the third empirical work whether the effect of stress exposure on the reward processing differentiates HC from HV. Since major depression is frequently characterized by altered cognitive processes (for a review see: Kujawa & Burkhouse, 2017), we further examined whether cognitive effort modulates the effect of stress exposure on reward processing, and whether cognitive effort influences differently the stress-induced effects on reward processing in HC and HV.

According to the reward hypo-responsivity model of major depression (Alloy et al., 2016), MDD patients are characterized by abnormalities in reward processing, including reduced striatal activation in response to cues predicting rewards (Forbes et al., 2010; Smoski et al., 2009), to reward delivery (Knutson & Greer, 2008; McCabe et al., 2012; Pizzagalli et al., 2009), and to reward prediction errors (Kumar et al., 2008; Steele, Kumar, & Ebmeier, 2007). Impaired reward processing is thought to constitute a vulnerability marker, as supported by decreased striatal reactivity to reward in first-degree relatives of depressed parents (Gotlib et al., 2010; McCabe et al., 2012; Monk et al., 2008; Olino et al., 2014; Olino, Silk, Osterritter, & Forbes, 2015; Sharp et al., 2014). Moreover, the reward hypo-responsivity model of major depression stipulates that stress exposure would contribute to alter the reward processing, resulting in the development of anhedonic symptoms (Hammen, 2005; Ingram & Luxton, 2005; Monroe & Simons, 1991). In contrast to this hypothesis, our results didn't evidence a general blunted responsiveness to reward cues and to reward notification in HV. Specifically, our findings showed a reduced recruitment of the caudate nucleus in all conditions in HV during the anticipation phase, and that NAcc reactivity in HV was modulated by stress exposure and cognitive load. Of primary importance for our results, the existing literature demonstrated a reduced recruitment of the caudate nucleus in depressed young adults during the anticipation phase (Olino et al., 2011), diminished caudate reactivity to reward cues in depressed patients (Pizzagalli et al., 2009; Stoy et al., 2012; Tricomi & Fiez, 2012), and a diminished caudate volume in depressed patients (Pizzagalli et al., 2009). Moreover, reduced caudate volume has been associated with stronger anhedonic symptoms in both depressed patients

(Pizzagalli et al., 2009) and healthy controls (Harvey et al., 2007). In line with these previous findings, our results suggest that reduced caudate reactivity might constitute a marker of increased vulnerability to major depression. Since the caudate nucleus subserves goal-driven behaviors resulting from action-outcome association learning (Grahn et al., 2008; Pizzagalli, 2014), diminished caudate engagement during anticipation in HV might reflect increased difficulty to learn action-outcome contingencies. Therefore, altered action-outcome association learning may increase the risk for the emergence of anhedonic symptoms, and the difficulties to engage in goal-directed behaviors. Such an assumption is supported by data showing that blunted caudate reactivity in MDD patients in response to reward cues normalized after a psychotherapy integrating behavioral activation (Dichter et al., 2009).

In accordance with studies indicating the presence of motivational deficits in MDD patients (Pechtel et al., 2013; Pizzagalli et al., 2009; Treadway, Bossaller, et al., 2012; Vrieze et al., 2013), our findings demonstrated that the NAcc reactivity in HV was strongly reduced by stress exposure during the anticipation phase, even more when the task required low cognitive demands. The NAcc has been particularly involved in the encoding of both the motivational valence and reward prediction error underlying reward learning (for a review see: Balleine & Killcross, 2006; see also: Gottfried et al., 2003; Pedroni et al., 2011). Of clinical importance, reduced NAcc responsiveness to rewards was linked to anhedonic symptoms, more specifically in individuals confronted to childhood adversity (Corral-Frías et al., 2015). In MDD patients, behavioral and neuroimaging studies reported (i) an increased difficulty to evaluate potential gains (Eshel & Roiser, 2010; Pizzagalli, 2014), (ii) an increased difficulty to modulate behaviors as a function of reward magnitude and reinforcement history (Pechtel et al., 2013; Pizzagalli et al., 2008; Treadway, Bossaller, et al., 2012), (iii) decreased willingness to exert effort to obtain a predicted reward (Vrieze et al., 2013), and (iv) blunted ventral striatum activation in response to cues predicting rewards (Hägele et al., 2015; Stringaris et al., 2015; Ubl, Kuehner, Kirsch, Ruttorf, Flor, et al., 2015). Based on findings in MDD patients, our results suggest that in HV, stress exposure alters NAcc reactivity during anticipation in a similar way as reward dysfunctions evidenced in MDD patients. In other words, stress exposure might constitute a vulnerability factor to the development of anhedonic symptoms for individuals at increased familial risk for MDD. Reduced NAcc reactivity during anticipation induced by stress exposure in HV who participated in our study might reflect a propensity to show dysfunctional valuation of incentives under stress exposure, which can further result in decreased motivation to pursue rewarding incentives, and to engage in pleasurable activities. NAcc reactivity during reward anticipation was particularly sensitive to stress exposure when cognitive demands were lower, which suggests that threatening environments might grab

more attention in task exerting lower cognitive load, resulting in stronger difficulties to encode reward value. In Figure 9.2 presented here after, we propose an integration of our findings along with the literature in MDD patients and individuals at increased risk for MDD discussed above, and illustrates the potential vulnerability markers for major depression that emerged from our third empirical work.

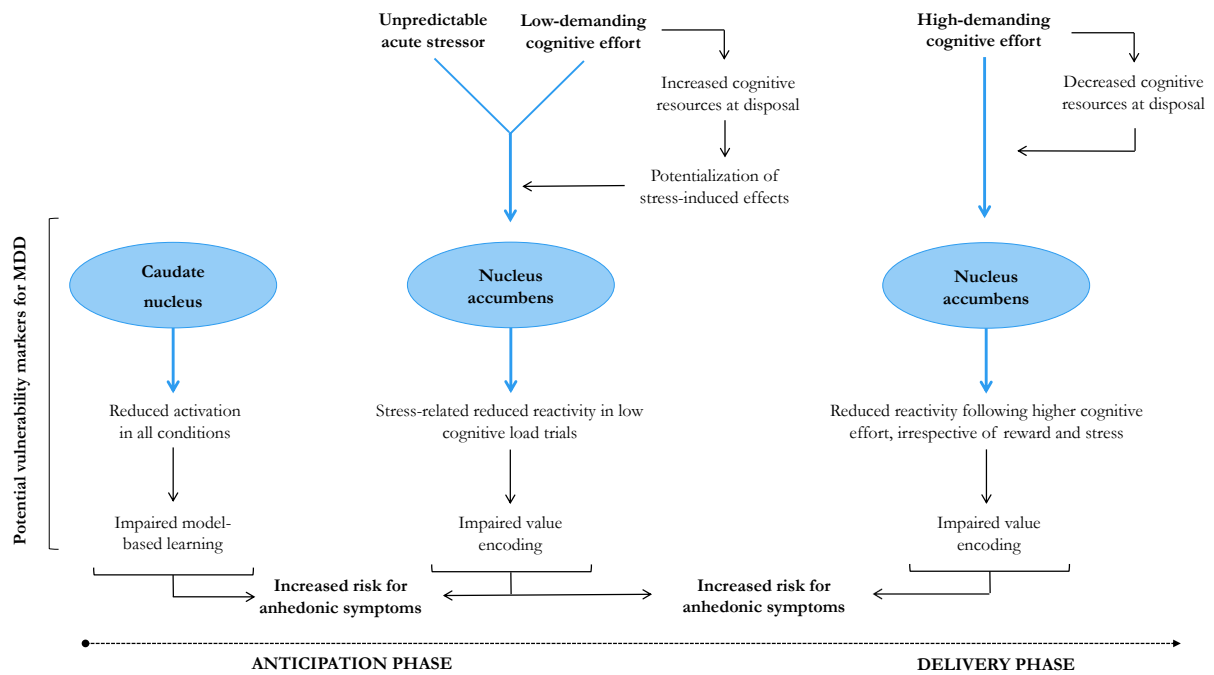

*Figure 9.2.* Illustration of the potential vulnerability markers for major depression disorder (MDD) proposed in the light of our third empirical work. This figure illustrates how stress and reward processes may interact during anticipation in healthy vulnerable (HV) individuals with increased familial risk for MDD, and how cognitive demands modulated stress-induced effects on striatal responsiveness. During the anticipation phase, HV showed a reduced caudate recruitment in all conditions, reflecting possibly impaired goal-directed learning that might promote increased difficulties to engage in goal-oriented behaviors. When the cognitive task is low-demanding, stress exposure might reduce nucleus accumbens reactivity during the anticipation phase, possibly through heightened attentional availability for stress-related informations. Reduced nucleus accumbens reactivity may further result in decreased ability to encode reward value in HV. Irrespective of stress exposure and of reinforcement, HV showed also diminished nucleus accumbens activation following the exertion of higher cognitive effort during the delivery phase, which might contribute to reduce their ability to encode reward value and consequently to engage in goal-oriented behaviors.

Taken together, our findings are in line with a recent re-conceptualization of anhedonia in major depression as deficits in motivation for reward (Sherdell, Waugh, & Gotlib, 2012; Treadway & Zald, 2011). In this view, anhedonia is characterized essentially by a reduced reactivity to cues predicting rewards, and by a decreased ability or willingness to engage in motivated behaviors to pursue pleasurable outcomes. In line with this re-conceptualization of anhedonia, our results

suggest that increased vulnerability to major depression might be associated with an impaired ability to learn both action-outcome and stimulus-outcome associations, along with an impaired ability to encode reward value. In conjunction with the role played by maladaptive emotion regulation strategies in reduced hedonic responsiveness to reward delivery (see Chapter 6 and section 9.2.3), our findings support the idea that disrupted higher-order cognitive functions might play a determinant role as vulnerability factor in major depression, in particular for the ability to encode the reward value resulting in increased risk for the development of anhedonic symptoms. Therefore, the reinforcement of cognitive regulatory processes might be of high relevance as prevention target in individuals at increased risk for major depression.

### 9.3 LIMITATIONS AND METHODOLOGICAL CONSIDERATIONS

The three empirical works presented in this thesis aimed at investigating how striatal reactivity to reward is affected by the exposure to an unpredictable acute stressor, and how variable levels of cognitive load modulate stress-induced effects on reward reactivity. Since increased stress sensitivity and cognitive impairments are strongly implicated in the pathophysiology of major depression, our purpose was to use depression vulnerability as a clinical model to test the implications of stress exposure on the reward responsiveness, and to examine how cognitive demands influence stress-induced effects on reward responsiveness, as potential risk factor for the development of anhedonic symptoms. Along with the encouraging findings they brought forth, our empirical works should be seen in the context of several limitations, described here after. These limitations have the advantage to point out the methodological challenges future studies will need to address.

#### 9.3.1 Small sample size

An important limitation is the size of the sample, small in regard to the complex three-way interaction considered in our first empirical work, and to the four-way interaction considered in the third one. The absence of threefold (stress  $\times$  reward  $\times$  load) interaction expected in our first empirical work and fourfold interaction (group  $\times$  stress  $\times$  reward  $\times$  load) hypothesized in our third empirical work is certainly due to the small number of participants. Since effects demonstrated in small sample size are less stable, future research is needed to replicate our findings in healthy adults and in vulnerable populations. Of particular importance, the effect sizes provided by our repeated-measures ANOVA analyses carried on brain activations reveal partial eta squared ( $\eta^2$ ) ranging from 0.24 to 0.36 in our first empirical work (see Table 5.1) and from 0.19 to 0.52 in our third empirical work (see Table 7.2). Thus, these effect sizes suggest that the significant main and interaction effects of stress exposure, reward, and cognitive load on striatal activations are reliable and explain between 20% to 50% of the total variance.

However, the small sample size limited the scope of possible analyses on the salivary cortisol data. The lack of statistical power resulting from the small sample size and the complexity of the model tested made impossible to evidence a response of the HPA system in participants during the stress condition of the Fribourg reward task. This issue is discussed in more details in the section 9.3.4 dedicated to the limitations and methodological considerations related to the measures of the biological HPA system. Taken together, caution is called for when generalizing the



present results that should therefore be considered in need of replication. Future studies with larger sample size will contribute to bringing insights into the role played by inter-individual variability in both stress sensitivity and reward responsiveness, and into the role of inter-individual variability in WM capacity on the stress-induced effects on reward responsiveness.

### **9.3.2 Characteristics of the healthy vulnerable sample**

Due to the limited number of participants, no distinction could be done in our analyses between the HV who lived with a depressed parent during their childhood, and HV who didn't live with a depressed parent. In other words, we couldn't assess how offspring's age at the onset of parental MDD, and the duration of parent's depressive episodes might act as a moderation effect. This might have increased inter-individual variability in terms of degree of vulnerability, since living with a depressed parent involves not only a genetic predisposition but also vulnerabilities stemming from the familial environment itself, such as the lack of attention and of positive reinforcement from the parent or schemas transmitted through education. A closer investigation of potential differences could help to identify the role played by nature and nurture in the face of vulnerability to major depression. Also, an important consideration to take into account is the possibility that our vulnerable sample was resilient, in the sense that they successfully crossed over the critical period of increased risk for the development of MDD occurring usually between 15 and 25 years old (Gotlib et al., 2014; Weissman et al., 2016).

### **9.3.3 Design of the study and experimental task**

The three empirical works embedded in the present thesis explored the effect of stress exposure on reward processing at the neural and behavioral levels using an event-related fMRI task. To manipulate the stress response, our experimental task comprised a control condition devoid of stress during the first block, and a stress condition including threat-of-shock induction during the second block. Given our within-subject design and in order to avoid the methodological issues of scanning on different days, participants performed the two blocks on the same day. In this context, no randomization was possible between blocks to avoid the potential bleeding of negative effects induced by threat-of-shock into the control condition. This is a limitation to take into account when interpreting the effects of stress on reward processing, and on behavioral performance. For instance, it is likely that a proportion of enhanced performance in the second

block was due to learning effect over the task, and not only to the stress-induced enhancing effect since the stress condition appeared always after the control condition.

With regard to the study design, a second limitation lies in the cross-sectional and correlational nature of the data reported in these empirical works. Interpreting the relationship linking neural activations to the psychological processes implicated during the reward processing is complex (K. C. Berridge & Kringelbach, 2015). Given the correlational nature of neuroimaging activations, brain regions activated during the reward delivery might, for instance, inform us about the causal role of these regions in the generation of pleasure and in its related functions. In contrast, another possibility is that these brain regions are not involved in the causation of pleasure *per se*, but only in the related functions that result from hedonic responsiveness, including among others reward valuation, reward learning or decision making based on the positive consequences that occurred during the delivery phase. An additional issue related to this second limitation is the difficulty to clearly distinguish between the different psychological processes involved during the anticipation and delivery phases of reward processing in the experimental fMRI tasks. One main reason is the lack of temporal space between these phases, leading possibly to overlaps between the fMRI BOLD responses of the anticipation and delivery phases. In the Fribourg reward task, the self-reported ratings occurred every four trials for a variable inter-trial intervals (approximately between 10 and 20 sec), so that it contributed to reducing this issue. Although it is not a perfect inter-trial interval that was *strictu sensu* randomized at the end of every trial, this issue was partly overcome by using orthogonalized analyses, or in other words, by the full crossing of conditions in the anticipation and delivery phases as in the MID task (Knutson & Greer, 2008).

#### **9.3.4 Failure to evidence stress-induced reactivity of the HPA system**

Although threat-of-shock successfully induced negative mood and strengthened the subjective experience of stress (see Chapter 5), salivary cortisol measurements failed to support the effectiveness of the stress manipulation to induce a clear activation of the biological stress system in participants, as described in the additional data exploration (see Chapter 8). This constitutes an important limitation since it is not certain that the effects produced by stress exposure were corroborated by stronger reactivity of the HPA system. Here after, we discuss several potential nuisance factors that might explain the failure to evidence a clear stress response of the HPA system in the stress condition of the Fribourg reward task.

The first one resides in the small sample size and the fact that multilevel modeling analyses are power intensive, even more in small sample size. The small sample size conditioned the

statistical multilevel modeling analyses that we were able to perform in order to assess the efficacy of the stress induction, probably due to the lack of statistical power. Second, large inter-individual variability occurred among participants in their reactivity to the experimental stressor, which certainly contributed to decreasing even more the statistical power of our analyses for detecting significant changes over time. This is in line with several studies that demonstrated the substantial inter-individual variability in the reactivity of the HPA system (for a review see: Bogdan et al., 2013). A third nuisance factor is related to the strong stressful effect induced by the scanning session itself. The stressful impact of fMRI environment combined to the absence of randomization have probably resulted in a first stress response at the entry into the scanner, with a small rebound during the stress condition, but too small to be detected statistically. Fourth, the repeated induction of mild electrical shocks might have led to a rapid habituation to these aversive stimuli, and therefore to a lack of significant biological stress response (Grillon & Baas, 2003). The combination of different types of stressor including, for instance, physical and social-evaluative threats increases usually the effectiveness of stress induction. However, given the focus of our empirical works on reward processing, the manipulation of social-evaluative feedback such as in the MIST (Dedovic et al., 2005) would have counteracted with the reward processes studied, so that the use of a physical stressor allowed to manipulate orthogonally stress induction and reinforcement.

In sum, the monitoring of biological parameters during stress exposure remains a complex methodological question. Salivary cortisol measurements impose to overcome several methodological constraints and issues, including the heterogeneity in temporal delay of the salivary cortisol response (Bali & Jaggi, 2015; Dickerson & Kemeny, 2004; F. R. Goodman, Disabato, Kashdan, & Kauffman, 2018; Kudielka et al., 2009), the diurnal variation of the cortisol concentration (e.g. Saxbe, 2008), the important inter-individual variability in the reactivity of the HPA system as a function of age and gender, with strong influence of the menstrual cycle (for reviews see: Kudielka et al., 2009; Kudielka & Kirschbaum, 2005). These constraints imposed by salivary cortisol measurements might explain the common lack of significant relationship in the literature between biological parameters and self-reported feelings of stress (Campbell & Ehlert, 2012). With the aim of overcoming the limitations related to salivary cortisol measurements, a major methodological question is to determine the most reliable biological parameters for the assessment of the reactivity of the HPA system.

## 9.4 FUTURE DIRECTIONS

With reference to the RDoC initiative launched by the National Institute of Mental Health (NIMH) (National Institute of Mental Health, 2009), our overarching objective was to identify potential mechanisms that might represent markers of vulnerability involved in reward processing abnormalities by providing a better understanding of the basic brain-behavior mechanisms implicated in the complex interaction linking acute stress exposure to the reward processing, and further how cognitive load modulates the way acute stress affects reward processing. In the present thesis, we focused on the processes associated with the reward anticipation and reward delivery based mainly on (i) the recruitment of brain regions, and (ii) the modulation of behavioral responses. Specifically, we explored how the mechanisms engaged in reward responsiveness interacted with the defensive motivational system activated by the induction of an unpredictable acute stressor, and how the cognitive system engaged by variable levels of WM load modulates the interaction between these two motivational systems. The empirical works developed in this thesis provide encouraging findings that open new questions and avenues.

First, our results suggest that stress exposure affects the motivation for reward, reward learning, and affective processes. A large extent of studies documented that acute and chronic stressors might result in dysfunctional reward processing including reduced incentive motivation, anhedonic reactions, and lack of reinforcement learning (for a review see: Pizzagalli, 2014). However, it remains often complex to disentangle learning processes from motivational and affective processes. Therefore, further studies are warranted to investigate how unpredictable acute stress influences the neural correlates of incentive motivation and hedonic capacities during experimental tasks involving different types of reinforcement learning, including for instance Pavlovian, and goal-directed learning processes. Such studies might bring important insights to understand the role of stress in the emergence of compulsive behaviors or in the lack of motivation to engage in goal-oriented behaviors. In this thesis, we focused on the motivational processes engaged during reward anticipation, and on the affective (i.e. hedonic) processes implicated during reward delivery.

Second, our findings indicate a key role played by stress and positive reinforcement in the sensitization of brain regions that might be recruited by the encoding of motivational salience, but also by the encoding of motivational valence. The use of additional behavioral and self-reported measures might clarify the mechanisms at play and whether the physiological responses and subjective experiences support neural correlates. Specifically, the motivational salience that one ascribes to a specific stimulus or event is reflected by the magnitude of arousal elicited by them (Kable & Glimcher, 2007; Kringelbach, 2007; Loewenstein, 2000; Zald & Treadway, 2017). The

magnitude of arousal is also commonly used as an indicator to assess the objective level of effort exerted in an instrumental task or, in other terms, the energizing effect induced by the reward (Brehm & Self, 1989). At the physiological level, a reliable and well-validated measure of motivational arousal and effort mobilization is the cardiovascular reactivity (Silvestrini, 2017), or pupil dilatation recorded with eye tracker (Bradley, Miccoli, Escrig, & Lang, 2008). At the subjective level, self-reported ratings might be added to assess the level of arousal experienced by asking participants to evaluate “How is your state?” on a visual analog scale ranging from ‘quite’ to ‘aroused’, for instance. The motivational valence represents the subjective value that one ascribes to a stimulus or the hedonic impact produced by the stimulus (Kringelbach, 2007). The assessment of stress effects on the encoding of reward valence might be achieved notably by combining the manipulation of stress (control condition, stress condition) with several positive reinforcement schedules (low reward, high reward) or in a more complex way, by including an additional negative reinforcement schedule (low punishment, high punishment). Adding these measures might deepen our understanding of the psychological, behavioral, and neural processes involved in incentive motivation.

Further, we aimed at exploring the hedonic responsiveness elicited by monetary reward during the delivery phase. Our results evidenced the influence of stress on the responsiveness of brain regions involved in sensorimotor coordination, motor preparation, efficient planning, and initiation of both goal-driven behaviors and more automatized behaviors. Third, although neural activation in response to reward provides a reliable objective measure of neural correlates involved in hedonic reactivity, future investigations might include self-reported ratings following the reward notification to assess the subjective hedonic feelings experienced during the reward receipt. Also, it might be relevant to include self-reported questionnaires in future studies to evaluate specifically the ability or inability to experience pleasure. These questionnaires comprise, for instance, the Snaith-Hamilton Pleasure Scale (Snaith et al., 1995) and the Fawcett-Clark Pleasure Capacity Scale (Fawcett, 1983). The inclusion of self-reported ratings of hedonic experience during reward delivery, self-reported questionnaires assessing the ability to experience hedonic feelings, and self-reported positive experiences in daily life might further contribute to explore the neural correlates of reward responsiveness associated specifically with the subjective feelings of pleasure. In this framework, the relationship linking the neural correlates of reward responsiveness and self-reported daily experiences is currently investigated in another work of our group (Guilod et al., 2019). Altogether, more studies are needed to clarify the impact of stress exposure on the motivational and affective components of reward processing, in terms of neural, behavioral, and self-reported responses.

Fourth, our findings indicated that stress exposure and cognitive effort modulate the vulnerability to major depression. Specifically, stress exposure showed an adverse effect on the ability of vulnerable individuals to MDD to evaluate the incentive value of cues predicting reward, particularly when less cognitive effort is required in the task. In contrast, the exertion of higher cognitive effort might hinder the ventral striatal function in HV during the delivery phase, resulting in the impaired encoding of reward value. Very few data exist so far on how stress exposure affects the reward processing in both MDD patients and individuals at increased vulnerability to MDD. This calls for further investigations exploring how different types of stressor might alter the ability of vulnerable individuals and MDD patients to engage in motivated behaviors, to experience hedonic feelings from rewards, and to learn from rewards in order to modulate behaviors. To our knowledge, no study had examined the modulatory role played by higher-order cognitive functions in the effect of stress exposure on reward processing in vulnerable individuals. Investigating the role of stress exposure and how higher-order cognitive functions might modulate stress-induced effect in vulnerable individuals and MDD patients might open new promising avenues to deepen our understanding of the etiological pathways leading to major depression, but also to relevant prevention and treatment targets.

Fifth, small sample sizes generally restrict the analyses and interpretations of findings as discussed in the limitations. Although they contribute to make a step towards a better understanding of the complex brain-behavior mechanisms, multicenter studies are essential for providing access to large sample sizes and for building a comprehensive framework of how these mechanisms develop from childhood to adulthood, and how motivational and regulatory systems interact in the face of life adversity. Several research consortia such as ABCD (see <https://abcdstudy.org>), NCANDA (see <https://ncanda.org>), IMAGEN (see <https://imagen-europe.com>) or Connectome (see [www.humanconnectome.org](http://www.humanconnectome.org)) provide large longitudinal datasets that open new promising avenues to uncover brain-behavior mechanisms. Among them, machine learning has recently emerged as a new powerful tool to develop models able to predict increased risk in vulnerable subjects based on predetermined classifiers or to identify patterns that might inform about the components of brain-behavior models (Bzdok & Meyer-Lindenberg, 2018; Dwyer, Falkai, & Koutsouleris, 2018). Briefly, machine learning is a data-driven approach using algorithms that train computers to learn patterns from a variety of data including neuroimaging, physiological, behavioral, or self-reported measures, with the overarching aim of identifying classifiers that might yield a predictive model of motivated behaviors and hedonic responsiveness, for instance (Ernst, Gowin, Gaillard, Philips, & Grillon, 2019). In sum, this new approach will certainly help to build a clearer understanding of brain-behavior mechanisms in normal conditions

and the factors implicated in the abnormalities of these mechanisms with the aim of drawing new prevention and treatment targets.





# CHAPTER 10

## CONCLUSION

---

# CONCLUSION

---

The motivation to pursue, to experience and/or to learn about primary or fundamental rewards is probably evolution's boldest trick to ensure survival and well-being. For several decades, researchers have carefully explored the neural and psychological mechanisms involved in this essential survival function. It is known as the concept of reward processing. Understanding the factors that can contribute to the breakdown of any or all of these mechanisms is therefore essential for developing promising prevention targets. Stress exposure was evidenced to have powerful effects on motivational (e.g. the willingness to engage in motivated behaviors), affective (e.g. hedonic responsivity), and cognitive (e.g. learning) processes. The inability to engage in reward-seeking motivated behaviors, to experience pleasure from hedonic stimuli, and to learn from positive pleasurable consequences are core symptoms of stress-related disorders, in particular of major depression.

In this framework, the overarching objective of this thesis was to provide a better understanding of the basic brain-behavior mechanisms implicated in the complex interaction linking acute stress exposure to incentive motivation and to hedonic responsivity, and further to explore how cognitive load modulates the way acute stress affects reward processing. Our findings indicate that unpredictable acute stress exposure might result in stronger arousal and strengthened reward-seeking motivation reflected by (i) a hyper-activation in the dorsal striatum to outcomes generally, (ii) stronger putamen recruitment in response to reward cues, and (iii) enhanced WM performance. This suggests that unpredictable acute stress exposure may contribute to switch the locus of control from the ventral to the dorsal striatum, fostering behavioral activation, habitual behaviors, and active coping strategies. Also, our results brought new insights into the role played by cognitive demands. Specifically, they suggest that the ability of the ventral striatum to encode reward value during reward delivery is impaired after more demanding cognitive effort, resulting possibly in reduced goal-directed behaviors driven by valued goals. Interestingly, our findings indicate that maladaptive emotion regulation is associated with diminished hedonic experiences in healthy individuals, as reflected by decreased ventral striatum reactivity to reward notification. Of particular clinical significance, the present thesis aimed also at uncovering how the neural and behavioral mechanisms at the interplay between stress and reward processes might constitute vulnerability factors in a population at increased familial risk for major depression. Altogether, our

findings revealed that increased familial vulnerability to depression might be associated with (i) abnormalities in reward learning processes including action-outcome and stimulus-outcome association learning, and (ii) impaired ability to encode incentive values, in particular after the exertion of higher cognitive effort.

Ultimately, we hope that the empirical works developed in this thesis will contribute, in the long run, to provide new insights enabling the emergence of more individualized and efficient prevention of stress-related psychopathological symptoms.



## REFERENCES

---

- Adam, E. K., Doane, L. D., Zinbarg, R. E., Mineka, S., Craske, M. G., & Griffith, J. W. (2010). Prospective prediction of major depressive disorder from cortisol awakening responses in adolescence. *Psychoneuroendocrinology*, *35*(6), 921-931. <https://doi.org/10.1016/j.psyneuen.2009.12.007>
- Adam, E. K., Quinn, M. E., Tavernier, R., McQuillan, M. T., Dahlke, K. A., & Gilbert, K. E. (2017). Diurnal cortisol slopes and mental and physical health outcomes: A systematic review and meta-analysis. *Psychoneuroendocrinology*, *83*, 25-41. <https://doi.org/10.1016/j.psyneuen.2017.05.018>
- Adam, T. C., & Epel, E. S. (2007). Stress, eating and the reward system. *Physiology & Behavior*, *91*(4), 449-458. <https://doi.org/10.1016/j.physbeh.2007.04.011>
- Admon, R., Lubin, G., Rosenblatt, J. D., Stern, O., Kahn, I., Assaf, M., & Hendler, T. (2013). Imbalanced neural responsivity to risk and reward indicates stress vulnerability in humans. *Cerebral Cortex*, *23*(1), 28-35. <https://doi.org/10.1093/cercor/bhr369>
- Admon, R., & Pizzagalli, D. A. (2015a). Corticostriatal pathways contribute to the natural time course of positive mood. *Nature Communications*, *6*(1). <https://doi.org/10.1038/ncomms10065>
- Admon, R., & Pizzagalli, D. A. (2015b). Dysfunctional reward processing in depression. *Current Opinion in Psychology*, *4*, 114-118. <https://doi.org/10.1016/j.copsyc.2014.12.011>
- Adolphs, R. (2013). The biology of fear. *Current Biology*, *23*(2), R79-R93. <https://doi.org/10.1016/j.cub.2012.11.055>
- Akaishi, R., & Hayden, B. Y. (2016). A spotlight on reward. *Neuron*, *90*(6), 1148-1150. <https://doi.org/10.1016/j.neuron.2016.06.008>
- Aldao, A., Nolen-Hoeksema, S., & Schweizer, S. (2010). Emotion-regulation strategies across psychopathology: A meta-analytic review. *Clinical Psychology Review*, *30*(2), 217-237. <https://doi.org/10.1016/j.cpr.2009.11.004>
- Alexander, G. E., & Crutcher, M. D. (1990). Functional architecture of basal ganglia circuits: Neural substrates of parallel processing. *Trends in Neurosciences*, *13*(7), 266-271. [https://doi.org/10.1016/0166-2236\(90\)90107-L](https://doi.org/10.1016/0166-2236(90)90107-L)
- Allen, A. P., Kennedy, P. J., Cryan, J. F., Dinan, T. G., & Clarke, G. (2014). Biological and psychological markers of stress in humans: Focus on the Trier Social Stress Test. *Neuroscience & Biobehavioral Reviews*, *38*, 94-124. <https://doi.org/10.1016/j.neubiorev.2013.11.005>
- Alloy, L. B., Olino, T., Freed, R. D., & Nusslock, R. (2016). Role of reward sensitivity and processing in major depressive and bipolar spectrum disorders. *Behavior Therapy*, *47*(5), 600-621. <https://doi.org/10.1016/j.beth.2016.02.014>
- Amaral, J. M. X. do, Spadaro, P. T. M., Pereira, V. M., Silva, A. C. de O. e, & Nardi, A. E. (2013). The carbon dioxide challenge test in panic disorder: A systematic review of preclinical and clinical research. *Revista Brasileira de Psiquiatria*, *35*(3), 318-331. <https://doi.org/10.1590/1516-4446-2012-1045>
- American Psychiatric Association. (2000). *Diagnostic and Statistical Manual of Mental Disorders (4th ed.)*. Washington, DC: American Psychiatric Publishing.
- American Psychiatric Association. (2013). *Diagnostic and Statistical Manual of Mental Disorders (5th ed.)*. Arlington, VA: American Psychiatric Publishing.
- Anderson, B. A., Kuwabara, H., Wong, D. F., Gean, E. G., Rahmim, A., Brašić, J. R., ... Yantis, S. (2016). The role of dopamine in value-based attentional orienting. *Current Biology*, *26*(4), 550-555. <https://doi.org/10.1016/j.cub.2015.12.062>
- Andreasen, N. C., Endicott, J., Spitzer, R. L., & Winokur, G. (1977). The family history method using diagnostic criteria. Reliability and validity. *Archives of General Psychiatry*, *34*(10), 1229-1235.
- Anisman, H., & Matheson, K. (2005). Stress, depression, and anhedonia: Caveats concerning animal models. *Neuroscience & Biobehavioral Reviews*, *29*(4-5), 525-546. <https://doi.org/10.1016/j.neubiorev.2005.03.007>
- Apps, M. A. J., Grima, L. L., Manohar, S., & Husain, M. (2015). The role of cognitive effort in subjective reward devaluation and risky decision-making. *Scientific Reports*, *5*(1). <https://doi.org/10.1038/srep16880>

- Arborelius, L. (1999). The role of corticotropin-releasing factor in depression and anxiety disorders. *Journal of Endocrinology*, *160*(1), 1-12. <https://doi.org/10.1677/joe.0.1600001>
- Armario, A. (2015). Studying chronic stress in animals: Purposes, models and consequences. In J. Russell & M. Shipston (Éd.), *Neuroendocrinology of Stress* (p. 143-168). <https://doi.org/10.1002/9781118921692.ch7>
- Arnsten, A. F. T., & Jin, L. E. (2014). Molecular influences on working memory circuits in dorsolateral prefrontal cortex. In *Progress in Molecular Biology and Translational Science* (Vol. 122, p. 211-231). <https://doi.org/10.1016/B978-0-12-420170-5.00008-8>
- Aubry, J.-M., Jermann, F., Gex-Fabry, M., Bockhorn, L., Van der Linden, M., Gervasoni, N., ... Bondolfi, G. (2010). The cortisol awakening response in patients remitted from depression. *Journal of Psychiatric Research*, *44*(16), 1199-1204. <https://doi.org/10.1016/j.jpsychires.2010.04.015>
- Auerbach, R. P., Admon, R., & Pizzagalli, D. A. (2014). Adolescent depression: Stress and reward dysfunction. *Harvard Review of Psychiatry*, *22*(3), 139-148. <https://doi.org/10.1097/HRP.0000000000000034>
- Avena, N. M., & Bocarsly, M. E. (2012). Dysregulation of brain reward systems in eating disorders: Neurochemical information from animal models of binge eating, bulimia nervosa, and anorexia nervosa. *Neuropharmacology*, *63*(1), 87-96. <https://doi.org/10.1016/j.neuropharm.2011.11.010>
- Baddeley, A. D. (2010). Working memory. *Current Biology*, *20*(4), R136-140. <https://doi.org/10.1016/j.cub.2009.12.014>
- Baddeley, A. D., & Hitch, G. (1974). Working memory. In *Psychology of Learning and Motivation* (Vol. 8, p. 47-89). [https://doi.org/10.1016/S0079-7421\(08\)60452-1](https://doi.org/10.1016/S0079-7421(08)60452-1)
- Baer, R. A. (2003). Mindfulness training as a clinical intervention: A conceptual and empirical review. *Clinical Psychology: Science and Practice*, *10*(2), 125-143. <https://doi.org/10.1093/clipsy/bpg015>
- Balderston, N. L., Hale, E., Hsiung, A., Torrisi, S., Holroyd, T., Carver, F. W., ... Grillon, C. (2017). Threat of shock increases excitability and connectivity of the intraparietal sulcus. *eLife*, *6*. <https://doi.org/10.7554/eLife.23608>
- Balderston, N. L., Vytal, K. E., O'Connell, K., Torrisi, S., Letkiewicz, A., Ernst, M., & Grillon, C. (2017). Anxiety patients show reduced working memory related dlPFC activation during safety and threat. *Depression and Anxiety*, *34*(1), 25-36. <https://doi.org/10.1002/da.22518>
- Bali, A., & Jaggi, A. S. (2015). Clinical experimental stress studies: Methods and assessment. *Reviews in the Neurosciences*, *26*(5). <https://doi.org/10.1515/revneuro-2015-0004>
- Ballard, K., & Knutson, B. (2009). Dissociable neural representations of future reward magnitude and delay during temporal discounting. *NeuroImage*, *45*(1), 143-150. <https://doi.org/10.1016/j.neuroimage.2008.11.004>
- Balleine, B. W., Delgado, M. R., & Hikosaka, O. (2007). The role of the dorsal striatum in reward and decision-making. *Journal of Neuroscience*, *27*(31), 8161-8165. <https://doi.org/10.1523/JNEUROSCI.1554-07.2007>
- Balleine, B. W., & Dickinson, A. (1998). Goal-directed instrumental action: Contingency and incentive learning and their cortical substrates. *Neuropharmacology*, *37*(4-5), 407-419.
- Balleine, B. W., & Gottfried, J. A. (2011). Sensation, incentive learning, and the motivational control of goal-directed action. In *Frontiers in Neuroscience. Neurobiology of Sensation and Reward* (p. 287-310). Boca Raton, FL: CRC Press/Taylor & Francis.
- Balleine, B. W., & Killcross, S. (2006). Parallel incentive processing: An integrated view of amygdala function. *Trends in Neurosciences*, *29*(5), 272-279. <https://doi.org/10.1016/j.tins.2006.03.002>
- Banich, M. T. (2009). Executive function: The search for an integrated account. *Current Directions in Psychological Science*, *18*(2), 89-94. <https://doi.org/10.1111/j.1467-8721.2009.01615.x>
- Bartlett, D. (1998). *Stress: Perspectives and processes*. Philadelphia, PA: Open University Press.
- Bartra, O., McGuire, J. T., & Kable, J. W. (2013). The valuation system: A coordinate-based meta-analysis of BOLD fMRI experiments examining neural correlates of subjective value. *NeuroImage*, *76*, 412-427. <https://doi.org/10.1016/j.neuroimage.2013.02.063>
- Baskin-Sommers, A. R., & Foti, D. (2015). Abnormal reward functioning across substance use disorders and major depressive disorder: Considering reward as a transdiagnostic mechanism. *International Journal of Psychophysiology: Official Journal of the International Organization of Psychophysiology*, *98*, 227-239. <https://doi.org/10.1016/j.ijpsycho.2015.01.011>

- Beck, A. T., Steer, R. A., & Brown, G. (1996). *Manual for the Beck Depression Inventory-II*. San Antonio, TX: Psychological Corporation.
- Beck, A. T., Steer, R. A., & Brown, G. (1998). *Inventaire de dépression de Beck*. Paris: Editions du Centre de psychologie appliquée.
- Beevers, C. (2005). Cognitive vulnerability to depression: A dual process model. *Clinical Psychology Review, 25*(7), 975-1002. <https://doi.org/10.1016/j.cpr.2005.03.003>
- Belmaker, R. H., & Agam, G. (2008). Major depressive disorder. *The New England Journal of Medicine, 358*(1), 55-68. <https://doi.org/10.1056/NEJMra073096>
- Belsky, J., Jonassaint, C., Pluess, M., Stanton, M., Brummett, B., & Williams, R. (2009). Vulnerability genes or plasticity genes? *Molecular Psychiatry, 14*(8), 746-754. <https://doi.org/10.1038/mp.2009.44>
- Berenbaum, H., & Connelly, J. (1993). The effect of stress on hedonic capacity. *Journal of Abnormal Psychology, 102*(3), 474-481. <http://dx.doi.org/10.1037/0021-843X.102.3.474>
- Berghorst, L. H., Bogdan, R., Frank, M. J., & Pizzagalli, D. A. (2013). Acute stress selectively reduces reward sensitivity. *Frontiers in Human Neuroscience, 7*(133), 1-15. <https://doi.org/10.3389/fnhum.2013.00133>
- Berridge, C. W., España, R. A., & Vittoz, N. M. (2010). Hypocretin/orexin in arousal and stress. *Brain Research, 1314*, 91-102. <https://doi.org/10.1016/j.brainres.2009.09.019>
- Berridge, K. C. (2004). Motivation concepts in behavioral neuroscience. *Physiology & Behavior, 81*(2), 179-209. <https://doi.org/10.1016/j.physbeh.2004.02.004>
- Berridge, K. C. (2009a). 'Liking' and 'wanting' food rewards: Brain substrates and roles in eating disorders. *Physiology & Behavior, 97*(5), 537-550. <https://doi.org/10.1016/j.physbeh.2009.02.044>
- Berridge, K. C. (2009b). Wanting and liking: Observations from the neuroscience and psychology laboratory. *Inquiry, 52*(4), 378-398. <https://doi.org/10.1080/00201740903087359>
- Berridge, K. C., & Aldridge, J. W. (2008). Decision utility, the brain, and pursuit of hedonic goals. *Social Cognition, 26*(5), 621-646. <https://doi.org/10.1521/soco.2008.26.5.621>
- Berridge, K. C., & Kringelbach, M. L. (2008). Affective neuroscience of pleasure: Reward in humans and animals. *Psychopharmacology, 199*(3), 457-480. <https://doi.org/10.1007/s00213-008-1099-6>
- Berridge, K. C., & Kringelbach, M. L. (2013). Neuroscience of affect: Brain mechanisms of pleasure and displeasure. *Current Opinion in Neurobiology, 23*(3), 294-303. <https://doi.org/10.1016/j.conb.2013.01.017>
- Berridge, K. C., & Kringelbach, M. L. (2015). Pleasure systems in the brain. *Neuron, 86*(3), 646-664. <https://doi.org/10.1016/j.neuron.2015.02.018>
- Berridge, K. C., & Robinson, T. E. (1998). What is the role of dopamine in reward: Hedonic impact, reward learning, or incentive salience? *Brain Research Reviews, 28*(3), 309-369. [https://doi.org/10.1016/S0165-0173\(98\)00019-8](https://doi.org/10.1016/S0165-0173(98)00019-8)
- Berridge, K. C., & Robinson, T. E. (2003). Parsing reward. *Trends in Neurosciences, 26*(9), 507-513. [https://doi.org/10.1016/S0166-2236\(03\)00233-9](https://doi.org/10.1016/S0166-2236(03)00233-9)
- Berridge, K. C., Robinson, T. E., & Aldridge, J. W. (2009). Dissecting components of reward: 'Liking', 'wanting', and learning. *Current Opinion in Pharmacology, 9*(1), 65-73. <https://doi.org/10.1016/j.coph.2008.12.014>
- Beshai, S., Dobson, K. S., Bockting, C. L. H., & Quigley, L. (2011). Relapse and recurrence prevention in depression: Current research and future prospects. *Clinical Psychology Review, 31*(8), 1349-1360. <https://doi.org/10.1016/j.cpr.2011.09.003>
- Bhagwagar, Z., Hafizi, S., & Cowen, P. J. (2003). Increase in concentration of waking salivary cortisol in recovered patients with depression. *American Journal of Psychiatry, 160*(10), 1890-1891. <https://doi.org/10.1176/appi.ajp.160.10.1890>
- Bhanji, J. P., & Delgado, M. R. (2014). The social brain and reward: Social information processing in the human striatum: Social brain and reward. *Wiley Interdisciplinary Reviews: Cognitive Science, 5*(1), 61-73. <https://doi.org/10.1002/wcs.1266>
- Bishop, M. P., Elder, S. T., & Heath, R. G. (1963). Intracranial self-stimulation in man. *Science, 140*(3565), 394-396.

- Bissonette, G. B., & Roesch, M. R. (2016). Development and function of the midbrain dopamine system: What we know and what we need to. *Genes, Brain and Behavior*, 15(1), 62-73. <https://doi.org/10.1111/gbb.12257>
- Blechert, J., Klackl, J., Miedl, S. F., & Wilhelm, F. H. (2016). To eat or not to eat: Effects of food availability on reward system activity during food picture viewing. *Appetite*, 99, 254-261. <https://doi.org/10.1016/j.appet.2016.01.006>
- Blood, A. J., & Zatorre, R. J. (2001). Intensely pleasurable responses to music correlate with activity in brain regions implicated in reward and emotion. *Proceedings of the National Academy of Sciences*, 98(20), 11818-11823. <https://doi.org/10.1073/pnas.191355898>
- Boecker, R., Holz, N. E., Buchmann, A. F., Blomeyer, D., Plichta, M. M., Wolf, I., ... Laucht, M. (2014). Impact of early life adversity on reward processing in young adults: EEG-fMRI results from a prospective study over 25 years. *PLoS ONE*, 9(8), e104185. <https://doi.org/10.1371/journal.pone.0104185>
- Boekhoudt, L., Wijbrans, E. C., Man, J. H. K., Luijendijk, M. C. M., de Jong, J. W., van der Plasse, G., ... Adan, R. A. H. (2018). Enhancing excitability of dopamine neurons promotes motivational behaviour through increased action initiation. *European Neuropsychopharmacology*, 28(1), 171-184. <https://doi.org/10.1016/j.euroneuro.2017.11.005>
- Bogdan, R., Nikolova, Y. S., & Pizzagalli, D. A. (2013). Neurogenetics of depression: A focus on reward processing and stress sensitivity. *Neurobiology of Disease*, 52, 12-23. <https://doi.org/10.1016/j.nbd.2012.05.007>
- Bogdan, R., & Pizzagalli, D. A. (2006). Acute stress reduces reward responsiveness: Implications for depression. *Biological Psychiatry*, 60(10), 1147-1154. <https://doi.org/10.1016/j.biopsych.2006.03.037>
- Boggero, I. A., Hostinar, C. E., Haak, E. A., Murphy, M. L. M., & Segerstrom, S. C. (2017). Psychosocial functioning and the cortisol awakening response: Meta-analysis, P-curve analysis, and evaluation of the evidential value in existing studies. *Biological Psychology*, 129, 207-230. <https://doi.org/10.1016/j.biopsycho.2017.08.058>
- Bolles, R. C. (1972). Reinforcement, expectancy, and learning. *Psychological Review*, 79, 394-409. <http://dx.doi.org/10.1037/h0033120>
- Bonnelle, V., Veromann, K.-R., Burnett Heyes, S., Lo Sterzo, E., Manohar, S., & Husain, M. (2015). Characterization of reward and effort mechanisms in apathy. *Journal of Physiology-Paris*, 109(1-3), 16-26. <https://doi.org/10.1016/j.jphysparis.2014.04.002>
- Botvinick, M. M., Huffstetler, S., & McGuire, J. T. (2009). Effort discounting in human nucleus accumbens. *Cognitive, Affective, & Behavioral Neuroscience*, 9(1), 16-27. <https://doi.org/10.3758/CABN.9.1.16>
- Botvinick, M. M., Niv, Y., & Barto, A. C. (2009). Hierarchically organized behavior and its neural foundations: A reinforcement learning perspective. *Cognition*, 113(3), 262-280. <https://doi.org/10.1016/j.cognition.2008.08.011>
- Bourke, C., Douglas, K., & Porter, R. (2010). Processing of facial emotion expression in major depression: A review. *The Australian and New Zealand Journal of Psychiatry*, 44(8), 681-696. <https://doi.org/10.3109/00048674.2010.496359>
- Bouvard, M., & Cottraux, J. (2010). *Protocoles et échelles d'évaluation en psychiatrie et psychologie*. Paris: Elsevier Masson.
- Bradley, M. M., Miccoli, L., Escrig, M. A., & Lang, P. J. (2008). The pupil as a measure of emotional arousal and autonomic activation. *Psychophysiology*, 45(4), 602-607. <https://doi.org/10.1111/j.1469-8986.2008.00654.x>
- Brehm, J. W., & Self, E. A. (1989). The intensity of motivation. *Annual Review of Psychology*, 40(1), 109-131. <https://doi.org/10.1146/annurev.ps.40.020189.000545>
- Breier, (1987). Controllable and uncontrollable stress in humans: Alterations in mood and neuroendocrine and psychophysiological function. *American Journal of Psychiatry*, 144(11), 1419-1425. <https://doi.org/10.1176/ajp.144.11.1419>
- Bromberg-Martin, E. S., Matsumoto, M., & Hikosaka, O. (2010). Dopamine in motivational control: Rewarding, aversive, and alerting. *Neuron*, 68(5), 815-834. <https://doi.org/10.1016/j.neuron.2010.11.022>
- Bromet, E., Andrade, L. H., Hwang, I., Sampson, N. A., Alonso, J., de Girolamo, G., ... Kessler, R. C. (2011). Cross-national epidemiology of DSM-IV major depressive episode. *BMC Medicine*, 9(1). <https://doi.org/10.1186/1741-7015-9-90>
- Buckman, J. E. J., Underwood, A., Clarke, K., Saunders, R., Hollon, S. D., Fearon, P., & Pilling, S. (2018). Risk factors for relapse and recurrence of depression in adults and how they operate: A four-phase systematic review and meta-synthesis. *Clinical Psychology Review*, 64, 13-38. <https://doi.org/10.1016/j.cpr.2018.07.005>



- Burke, H. M., Davis, M. C., Otte, C., & Mohr, D. C. (2005). Depression and cortisol responses to psychological stress: A meta-analysis. *Psychoneuroendocrinology*, *30*(9), 846-856. <https://doi.org/10.1016/j.psyneuen.2005.02.010>
- Burton, A. C., Kashtelyan, V., Bryden, D. W., & Roesch, M. R. (2014). Increased firing to cues that predict low-value reward in the medial orbitofrontal cortex. *Cerebral Cortex*, *24*(12), 3310-3321. <https://doi.org/10.1093/cercor/bht189>
- Burton, A. C., Nakamura, K., & Roesch, M. R. (2015). From ventral-medial to dorsal-lateral striatum: Neural correlates of reward-guided decision-making. *Neurobiology of Learning and Memory*, *117*, 51-59. <https://doi.org/10.1016/j.nlm.2014.05.003>
- Bzdok, D., & Meyer-Lindenberg, A. (2018). Machine learning for precision psychiatry: Opportunities and challenges. *Biological Psychiatry: Cognitive Neuroscience and Neuroimaging*, *3*(3), 223-230. <https://doi.org/10.1016/j.bpsc.2017.11.007>
- Cabib, S., & Puglisi-Allegra, S. (1996). Stress, depression and the mesolimbic dopamine system. *Psychopharmacology*, *128*(4), 331-342.
- Cabib, S., & Puglisi-Allegra, S. (2012). The mesoaccumbens dopamine in coping with stress. *Neuroscience & Biobehavioral Reviews*, *36*(1), 79-89. <https://doi.org/10.1016/j.neubiorev.2011.04.012>
- Cambridge, O. R., Knight, M. J., Mills, N., & Baune, B. T. (2018). The clinical relationship between cognitive impairment and psychosocial functioning in major depressive disorder: A systematic review. *Psychiatry Research*, *269*, 157-171. <https://doi.org/10.1016/j.psychres.2018.08.033>
- Campbell, J., & Ehlert, U. (2012). Acute psychosocial stress: Does the emotional stress response correspond with physiological responses? *Psychoneuroendocrinology*, *37*(8), 1111-1134. <https://doi.org/10.1016/j.psyneuen.2011.12.010>
- Cannon, W. B. (1929). Organization for physiological homeostasis. *Physiological Reviews*, *9*(3), 399-431. <https://doi.org/10.1152/physrev.1929.9.3.399>
- Cannon, W. B. (1932). *The wisdom of the body*. New York, NY: Norton.
- Cardinal, R. N., Parkinson, J. A., Hall, J., & Everitt, B. J. (2002). Emotion and motivation: The role of the amygdala, ventral striatum, and prefrontal cortex. *Neuroscience and Biobehavioral Reviews*, *26*(3), 321-352.
- Carl, H., Walsh, E., Eisenlohr-Moul, T., Minkel, J., Crowther, A., Moore, T., ... Smoski, M. J. (2016). Sustained anterior cingulate cortex activation during reward processing predicts response to psychotherapy in major depressive disorder. *Journal of Affective Disorders*, *203*, 204-212. <https://doi.org/10.1016/j.jad.2016.06.005>
- Cartoni, E., Balleine, B. W., & Baldassarre, G. (2016). Appetitive Pavlovian-instrumental transfer: A review. *Neuroscience & Biobehavioral Reviews*, *71*, 829-848. <https://doi.org/10.1016/j.neubiorev.2016.09.020>
- Caspi, A. (2003). Influence of life stress on depression: Moderation by a polymorphism in the 5-HTT gene. *Science*, *301*(5631), 386-389. <https://doi.org/10.1126/science.1083968>
- Castro, D. C., & Berridge, K. C. (2014). Advances in the neurobiological bases for food 'liking' versus 'wanting'. *Physiology & Behavior*, *136*, 22-30. <https://doi.org/10.1016/j.physbeh.2014.05.022>
- Czakoff, B. N., Johnson, K. J., & Howland, J. G. (2010). Converging effects of acute stress on spatial and recognition memory in rodents: A review of recent behavioural and pharmacological findings. *Progress in Neuro-Psychopharmacology and Biological Psychiatry*, *34*(5), 733-741. <https://doi.org/10.1016/j.pnpb.2010.04.002>
- Chamberlain, S. R., & Sahakian, B. J. (2006). The neuropsychology of mood disorders. *Current Psychiatry Reports*, *8*(6), 458-463.
- Chapman, L. J., Chapman, J. P., & Raulin, M. L. (1976). Scales for physical and social anhedonia. *Journal of Abnormal Psychology*, *85*(4), 374-382. <https://doi.org/10.1037/0021-843X.85.4.374>
- Charbonnier, L., van Meer, F., van der Laan, L. N., Viergever, M. A., & Smeets, P. A. M. (2016). Standardized food images: A photographing protocol and image database. *Appetite*, *96*, 166-173. <https://doi.org/10.1016/j.appet.2015.08.041>
- Chatham, C. H., & Badre, D. (2015). Multiple gates on working memory. *Current Opinion in Behavioral Sciences*, *1*, 23-31. <https://doi.org/10.1016/j.cobeha.2014.08.001>

- Chen, Y., & Baram, T. Z. (2016). Toward understanding how early-life stress reprograms cognitive and emotional brain networks. *Neuropsychopharmacology: Official Publication of the American College of Neuropsychopharmacology*, 41(1), 197-206. <https://doi.org/10.1038/npp.2015.181>
- Cho, Y. T., Fromm, S., Guyer, A. E., Detloff, A., Pine, D. S., Fudge, J. L., & Ernst, M. (2013). Nucleus accumbens, thalamus and insula connectivity during incentive anticipation in typical adults and adolescents. *NeuroImage*, 66, 508-521. <https://doi.org/10.1016/j.neuroimage.2012.10.013>
- Choi, E. Y., Yeo, B. T. T., & Buckner, R. L. (2012). The organization of the human striatum estimated by intrinsic functional connectivity. *Journal of Neurophysiology*, 108(8), 2242-2263. <https://doi.org/10.1152/jn.00270.2012>
- Choi, J. M., Padmala, S., & Pessoa, L. (2015). Counteracting effect of threat on reward enhancements during working memory. *Cognition and Emotion*, 29(8), 1517-1526. <https://doi.org/10.1080/02699931.2014.993596>
- Choi, J. M., Padmala, S., Spechler, P., & Pessoa, L. (2014). Pervasive competition between threat and reward in the brain. *Social Cognitive and Affective Neuroscience*, 9(6), 737-750. <https://doi.org/10.1093/scan/nst053>
- Chrousos, G. P. (2009). Stress and disorders of the stress system. *Nature Reviews Endocrinology*, 5(7), 374-381. <https://doi.org/10.1038/nrendo.2009.106>
- Chung, Y. S., & Barch, D. (2015). Anhedonia is associated with reduced incentive cue related activation in the basal ganglia. *Cognitive, Affective & Behavioral Neuroscience*, 15(4), 749-767. <https://doi.org/10.3758/s13415-015-0366-3>
- Clark, D. A., & Beck, A. T. (2010). Cognitive theory and therapy of anxiety and depression: Convergence with neurobiological findings. *Trends in Cognitive Sciences*, 14(9), 418-424. <https://doi.org/10.1016/j.tics.2010.06.007>
- Cohen, R. (2001). Impairments of attention and effort among patients with major affective disorders. *Journal of Neuropsychiatry*, 13(3), 385-395. <https://doi.org/10.1176/appi.neuropsych.13.3.385>
- Collette, F., & Van der Linden, M. (2002). Brain imaging of the central executive component of working memory. *Neuroscience and Biobehavioral Reviews*, 26(2), 105-125.
- Cools, R., & D'Esposito, M. (2011). Inverted-U-shaped dopamine actions on human working memory and cognitive control. *Biological Psychiatry*, 69(12), e113-e125. <https://doi.org/10.1016/j.biopsych.2011.03.028>
- Cools, R., & Robbins, T. W. (2004). Chemistry of the adaptive mind. *Philosophical Transactions of the Royal Society of London. Series A: Mathematical, Physical and Engineering Sciences*, 362(1825), 2871-2888. <https://doi.org/10.1098/rsta.2004.1468>
- Corral-Frías, N. S., Nikolova, Y. S., Michalski, L. J., Baranger, D. A. A., Hariri, A. R., & Bogdan, R. (2015). Stress-related anhedonia is associated with ventral striatum reactivity to reward and transdiagnostic psychiatric symptomatology. *Psychological Medicine*, 45(12), 2605-2617. <https://doi.org/10.1017/S0033291715000525>
- Cox, R. W. (1996). AFNI: Software for analysis and visualization of functional magnetic resonance neuroimages. *Computers and Biomedical Research, an International Journal*, 29(3), 162-173.
- Cox, R. W., Chen, G., Glen, D. R., Reynolds, R. C., & Taylor, P. A. (2017). FMRI clustering in AFNI: False-positive rates redux. *Brain Connectivity*, 7(3), 152-171. <https://doi.org/10.1089/brain.2016.0475>
- Craig, A. D. (2009). How do you feel — now? The anterior insula and human awareness. *Nature Reviews Neuroscience*, 10(1), 59-70. <https://doi.org/10.1038/nrn2555>
- Cromwell, H. C., & Schultz, W. (2003). Effects of expectations for different reward magnitudes on neuronal activity in primate striatum. *Journal of Neurophysiology*, 89(5), 2823-2838. <https://doi.org/10.1152/jn.01014.2002>
- Crosson, P. L., Walton, M. E., O'Reilly, J. X., Behrens, T. E. J., & Rushworth, M. F. S. (2009). Effort-based cost-benefit valuation and the human brain. *The Journal of Neuroscience: The Official Journal of the Society for Neuroscience*, 29(14), 4531-4541. <https://doi.org/10.1523/JNEUROSCI.4515-08.2009>
- Cuthbert, B. N., Schupp, H. T., Bradley, M. M., Birbaumer, N., & Lang, P. J. (2000). Brain potentials in affective picture processing: Covariation with autonomic arousal and affective report. *Biological Psychology*, 52(2), 95-111.
- D'Ardenne, K., Eshel, N., Luka, J., Lenartowicz, A., Nystrom, L. E., & Cohen, J. D. (2012). Role of prefrontal cortex and the midbrain dopamine system in working memory updating. *Proceedings of the National Academy of Sciences of the United States of America*, 109(49), 19900-19909. <https://doi.org/10.1073/pnas.1116727109>

- Darwin, C. (1872). *The expression of the emotions in man and animals*. London, United Kingdom: John Murray.
- Davidson, R. J., Pizzagalli, D., Nitschke, J. B., & Putnam, K. (2002). Depression: Perspectives from affective neuroscience. *Annual Review of Psychology*, *53*(1), 545-574. <https://doi.org/10.1146/annurev.psych.53.100901.135148>
- Davis, M., Walker, D. L., Miles, L., & Grillon, C. (2010). Phasic vs sustained fear in rats and humans: Role of the extended amygdala in fear vs anxiety. *Neuropsychopharmacology*, *35*(1), 105-135. <https://doi.org/10.1038/npp.2009.109>
- Daw, N. D., Niv, Y., & Dayan, P. (2005). Uncertainty-based competition between prefrontal and dorsolateral striatal systems for behavioral control. *Nature Neuroscience*, *8*(12), 1704-1711. <https://doi.org/10.1038/nn1560>
- Dayan, P., & Balleine, B. W. (2002). Reward, motivation, and reinforcement learning. *Neuron*, *36*(2), 285-298.
- de Water, E., Mies, G. W., Figner, B., Yoncheva, Y., van den Bos, W., Castellanos, F. X., ... Scheres, A. (2017). Neural mechanisms of individual differences in temporal discounting of monetary and primary rewards in adolescents. *NeuroImage*, *153*, 198-210. <https://doi.org/10.1016/j.neuroimage.2017.04.013>
- Dean, J., & Keshavan, M. (2017). The neurobiology of depression: An integrated view. *Asian Journal of Psychiatry*, *27*, 101-111. <https://doi.org/10.1016/j.ajp.2017.01.025>
- Dedovic, K., & Ngiam, J. (2015). The cortisol awakening response and major depression: Examining the evidence. *Neuropsychiatric Disease and Treatment*, *11*, 1181-1189. <https://doi.org/10.2147/NDT.S62289>
- Dedovic, K., Renwick, R., Mahani, N. K., Engert, V., Lupien, S. J., & Pruessner, J. C. (2005). The Montreal Imaging Stress Task: Using functional imaging to investigate the effects of perceiving and processing psychosocial stress in the human brain. *Journal of Psychiatry & Neuroscience: JPN*, *30*(5), 319-325.
- Dedovic, K., Rexroth, M., Wolff, E., Duchesne, A., Scherling, C., Beaudry, T., ... Pruessner, J. C. (2009). Neural correlates of processing stressful information: An event-related fMRI study. *Brain Research*, *1293*, 49-60. <https://doi.org/10.1016/j.brainres.2009.06.044>
- Delgado, M. R. (2007). Reward-related responses in the human striatum. *Annals of the New York Academy of Sciences*, *1104*, 70-88. <https://doi.org/10.1196/annals.1390.002>
- Delgado, M. R., Li, J., Schiller, D., & Phelps, E. A. (2008). The role of the striatum in aversive learning and aversive prediction errors. *Philosophical Transactions of the Royal Society of London. Series B, Biological Sciences*, *363*(1511), 3787-3800. <https://doi.org/10.1098/rstb.2008.0161>
- Der-Avakian, A., & Markou, A. (2012). The neurobiology of anhedonia and other reward-related deficits. *Trends in Neurosciences*, *35*(1), 68-77. <https://doi.org/10.1016/j.tins.2011.11.005>
- Desikan, R. S., Ségonne, F., Fischl, B., Quinn, B. T., Dickerson, B. C., Blacker, D., ... Killiany, R. J. (2006). An automated labeling system for subdividing the human cerebral cortex on MRI scans into gyral based regions of interest. *NeuroImage*, *31*(3), 968-980. <https://doi.org/10.1016/j.neuroimage.2006.01.021>
- Destrieux, C., Fischl, B., Dale, A., & Halgren, E. (2010). Automatic parcellation of human cortical gyri and sulci using standard anatomical nomenclature. *NeuroImage*, *53*(1), 1-15. <https://doi.org/10.1016/j.neuroimage.2010.06.010>
- Diamond, A. (2013). Executive functions. *Annual Review of Psychology*, *64*, 135-168. <https://doi.org/10.1146/annurev-psych-113011-143750>
- Dichter, G. S., Felder, J. N., Petty, C., Bizzell, J., Ernst, M., & Smoski, M. J. (2009). The effects of psychotherapy on neural responses to rewards in major depression. *Biological Psychiatry*, *66*(9), 886-897. <https://doi.org/10.1016/j.biopsych.2009.06.021>
- Dichter, G. S., Kozink, R. V., McClernon, F. J., & Smoski, M. J. (2012). Remitted major depression is characterized by reward network hyperactivation during reward anticipation and hypoactivation during reward outcomes. *Journal of Affective Disorders*, *136*(3), 1126-1134. <https://doi.org/10.1016/j.jad.2011.09.048>
- Dickerson, S. S., & Kemeny, M. E. (2004). Acute stressors and cortisol responses: A theoretical integration and synthesis of laboratory research. *Psychological Bulletin*, *130*(3), 355-391. <https://doi.org/10.1037/0033-2909.130.3.355>
- Dickinson, A., & Balleine, B. W. (1994). Motivational control of goal-directed action. *Animal Learning & Behavior*, *22*(1), 1-18. <https://doi.org/10.3758/BF03199951>

- Diekhof, E. K., Kaps, L., Falkai, P., & Gruber, O. (2012). The role of the human ventral striatum and the medial orbitofrontal cortex in the representation of reward magnitude – An activation likelihood estimation meta-analysis of neuroimaging studies of passive reward expectancy and outcome processing. *Neuropsychologia*, *50*(7), 1252-1266. <https://doi.org/10.1016/j.neuropsychologia.2012.02.007>
- Dienes, K. A., Hazel, N. A., & Hammen, C. L. (2013). Cortisol secretion in depressed, and at-risk adults. *Psychoneuroendocrinology*, *38*(6), 927-940. <https://doi.org/10.1016/j.psyneuen.2012.09.019>
- Dillon, D. G., Holmes, A. J., Birk, J. L., Brooks, N., Lyons-Ruth, K., & Pizzagalli, D. A. (2009). Childhood adversity is associated with left basal ganglia dysfunction during reward anticipation in adulthood. *Biological Psychiatry*, *66*(3), 206-213. <https://doi.org/10.1016/j.biopsych.2009.02.019>
- Dillon, D. G., Rosso, I. M., Pechtel, P., Killgore, W. D. S., Rauch, S. L., & Pizzagalli, D. A. (2014). Peril and pleasure: An RDOc-inspired examination of threat responses and reward processing in anxiety and depression. *Depression and Anxiety*, *31*(3), 233-249. <https://doi.org/10.1002/da.22202>
- Donkers, F. C. L., Nieuwenhuis, S., & van Boxtel, G. J. M. (2005). Medial frontal negativities in the absence of responding. *Cognitive Brain Research*, *25*(3), 777-787. <https://doi.org/10.1016/j.cogbrainres.2005.09.007>
- Duncko, R., Johnson, L., Merikangas, K., & Grillon, C. (2009). Working memory performance after acute exposure to the cold pressor stress in healthy volunteers. *Neurobiology of Learning and Memory*, *91*(4), 377-381. <https://doi.org/10.1016/j.nlm.2009.01.006>
- Dwyer, D. B., Falkai, P., & Koutsouleris, N. (2018). Machine learning approaches for clinical psychology and psychiatry. *Annual Review of Clinical Psychology*, *14*(1), 91-118. <https://doi.org/10.1146/annurev-clinpsy-032816-045037>
- Eklund, A., Nichols, T. E., & Knutsson, H. (2016). Cluster failure: Why fMRI inferences for spatial extent have inflated false-positive rates. *Proceedings of the National Academy of Sciences*, *113*(28), 7900-7905. <https://doi.org/10.1073/pnas.1602413113>
- Elzinga, B. M., & Roelofs, K. (2005). Cortisol-induced impairments of working memory require acute sympathetic activation. *Behavioral Neuroscience*, *119*(1), 98-103. <https://doi.org/10.1037/0735-7044.119.1.98>
- Engle, R. W. (2002). Working memory capacity as executive attention. *Current Directions in Psychological Science*, *11*(1), 19-23. <https://doi.org/10.1111/1467-8721.00160>
- Epstein, J., Pan, H., Kocsis, J. H., Yang, Y., Butler, T., Chusid, J., ... Silbersweig, D. A. (2006). Lack of ventral striatal response to positive stimuli in depressed versus normal subjects. *American Journal of Psychiatry*, *163*(10), 1784-1790. <https://doi.org/10.1176/ajp.2006.163.10.1784>
- Erk, S., Mikschl, A., Stier, S., Ciaramidaro, A., Gapp, V., Weber, B., & Walter, H. (2010). Acute and sustained effects of cognitive emotion regulation in major depression. *Journal of Neuroscience*, *30*(47), 15726-15734. <https://doi.org/10.1523/JNEUROSCI.1856-10.2010>
- Ernst, M. (2014). The triadic model perspective for the study of adolescent motivated behavior. *Brain and Cognition*, *89*, 104-111. <https://doi.org/10.1016/j.bandc.2014.01.006>
- Ernst, M., Gowin, J., Gaillard, C., Philips, R., & Grillon, C. (2019). Sketching the Power of Machine Learning to Decrypt a Neural Systems Model of Behavior. *Brain Sciences*, *9*(3), 67. <https://doi.org/10.3390/brainsci9030067>
- Ernst, M., Lago, T., Davis, A., & Grillon, C. (2016). The effects of methylphenidate and propranolol on the interplay between induced-anxiety and working memory. *Psychopharmacology*, *233*(19-20), 3565-3574. <https://doi.org/10.1007/s00213-016-4390-y>
- Ernst, M., Nelson, E. E., McClure, E. B., Monk, C. S., Munson, S., Eshel, N., ... Pine, D. S. (2004). Choice selection and reward anticipation: An fMRI study. *Neuropsychologia*, *42*(12), 1585-1597. <https://doi.org/10.1016/j.neuropsychologia.2004.05.011>
- Ernst, M., Torrisi, S., Balderston, N., Grillon, C., & Hale, E. A. (2015). fMRI functional connectivity applied to adolescent neurodevelopment. *Annual Review of Clinical Psychology*, *11*(1), 361-377. <https://doi.org/10.1146/annurev-clinpsy-032814-112753>
- Eshel, N., & Roiser, J. P. (2010). Reward and punishment processing in depression. *Biological Psychiatry*, *68*(2), 118-124. <https://doi.org/10.1016/j.biopsych.2010.01.027>

- Esterman, M., Grosso, M., Liu, G., Mitko, A., Morris, R., & DeGutis, J. (2016). Anticipation of monetary reward can attenuate the vigilance decrement. *PLOS ONE*, *11*(7), e0159741. <https://doi.org/10.1371/journal.pone.0159741>
- Etkin, A., Büchel, C., & Gross, J. J. (2015). The neural bases of emotion regulation. *Nature Reviews. Neuroscience*, *16*(11), 693-700. <https://doi.org/10.1038/nrn4044>
- Everaert, J., Duyck, W., & Koster, E. H. W. (2015). Emotionally biased cognitive processes: The weakest link predicts prospective changes in depressive symptom severity. *PLOS ONE*, *10*(5), e0124457. <https://doi.org/10.1371/journal.pone.0124457>
- Everaert, J., Grahek, I., & Koster, E. H. W. (2017). Individual differences in cognitive control over emotional material modulate cognitive biases linked to depressive symptoms. *Cognition and Emotion*, *31*(4), 736-746. <https://doi.org/10.1080/02699931.2016.1144562>
- Everitt, B. J., Belin, D., Economidou, D., Pelloux, Y., Dalley, J. W., & Robbins, T. W. (2008). Neural mechanisms underlying the vulnerability to develop compulsive drug-seeking habits and addiction. *Philosophical Transactions of the Royal Society B: Biological Sciences*, *363*(1507), 3125-3135. <https://doi.org/10.1098/rstb.2008.0089>
- Everitt, B. J., & Robbins, T. W. (2005). Neural systems of reinforcement for drug addiction: From actions to habits to compulsion. *Nature Neuroscience*, *8*(11), 1481-1489. <https://doi.org/10.1038/nn1579>
- Everitt, B. J., & Robbins, T. W. (2013). From the ventral to the dorsal striatum: Devolving views of their roles in drug addiction. *Neuroscience & Biobehavioral Reviews*, *37*(9), 1946-1954. <https://doi.org/10.1016/j.neubiorev.2013.02.010>
- Fareri, D. S., & Tottenham, N. (2016). Effects of early life stress on amygdala and striatal development. *Developmental Cognitive Neuroscience*, *19*, 233-247. <https://doi.org/10.1016/j.dcn.2016.04.005>
- Fawcett, J. (1983). Assessing anhedonia in psychiatric patients: The pleasure scale. *Archives of General Psychiatry*, *40*(1), 79. <https://doi.org/10.1001/archpsyc.1983.01790010081010>
- Feng, C., Li, W., Tian, T., Luo, Y., Gu, R., Zhou, C., & Luo, Y. (2014). Arousal modulates valence effects on both early and late stages of affective picture processing in a passive viewing task. *Social Neuroscience*, *9*(4), 364-377. <https://doi.org/10.1080/17470919.2014.896827>
- Fiallos, A. M., Bricault, S. J., Cai, L. X., Worku, H. A., Colonnese, M. T., Westmeyer, G. G., & Jasanoff, A. (2017). Reward magnitude tracking by neural populations in ventral striatum. *NeuroImage*, *146*, 1003-1015. <https://doi.org/10.1016/j.neuroimage.2016.10.036>
- Field, A. P. (2013). *Discovering statistics using IBM SPSS statistics: And sex and drugs and rock « n » roll* (4th edition). Los Angeles, CA: Sage.
- Fischl, B. (2004). Automatically Parcellating the Human Cerebral Cortex. *Cerebral Cortex*, *14*(1), 11-22. <https://doi.org/10.1093/cercor/bhg087>
- Foa, E. B., Zinbarg, R., & Rothbaum, B. O. (1992). Uncontrollability and unpredictability in post-traumatic stress disorder: An animal model. *Psychological Bulletin*, *112*(2), 218-238. <https://doi.org/10.1037//0033-2909.112.2.218>
- Fonov, V., Evans, A., McKinstry, R., Almlí, C., & Collins, D. (2009). Unbiased nonlinear average age-appropriate brain templates from birth to adulthood. *NeuroImage*, *47*, S102. [https://doi.org/10.1016/S1053-8119\(09\)70884-5](https://doi.org/10.1016/S1053-8119(09)70884-5)
- Forbes, E. E., & Dahl, R. E. (2010). Pubertal development and behavior: Hormonal activation of social and motivational tendencies. *Brain and Cognition*, *72*(1), 66-72. <https://doi.org/10.1016/j.bandc.2009.10.007>
- Forbes, E. E., Ryan, N. D., Phillips, M. L., Manuck, S. B., Worthman, C. M., Moyles, D. L., ... Dahl, R. E. (2010). Healthy adolescents' neural response to reward: Associations with puberty, positive affect, and depressive symptoms. *Journal of the American Academy of Child & Adolescent Psychiatry*, *49*(2), 162-172e5. <https://doi.org/10.1097/00004583-201002000-00010>
- Frank, D. W., Dewitt, M., Hudgens-Haney, M., Schaeffer, D. J., Ball, B. H., Schwarz, N. F., ... Sabatinelli, D. (2014). Emotion regulation: Quantitative meta-analysis of functional activation and deactivation. *Neuroscience & Biobehavioral Reviews*, *45*, 202-211. <https://doi.org/10.1016/j.neubiorev.2014.06.010>
- Frodil, T., & O'Keane, V. (2013). How does the brain deal with cumulative stress? A review with focus on developmental stress, HPA axis function and hippocampal structure in humans. *Neurobiology of Disease*, *52*, 24-37. <https://doi.org/10.1016/j.nbd.2012.03.012>

- Frost, R., & McNaughton, N. (2017). The neural basis of delay discounting: A review and preliminary model. *Neuroscience & Biobehavioral Reviews*, 79, 48-65. <https://doi.org/10.1016/j.neubiorev.2017.04.022>
- Fuentes-Claramonte, P., Ávila, C., Rodríguez-Pujadas, A., Ventura-Campos, N., Bustamante, J. C., Costumero, V., ... Barrós-Loscertales, A. (2015). Reward sensitivity modulates brain activity in the prefrontal cortex, ACC and striatum during task switching. *PLoS One*, 10(4), e0123073. <https://doi.org/10.1371/journal.pone.0123073>
- Gan, J. O., Walton, M. E., & Phillips, P. E. M. (2010). Dissociable cost and benefit encoding of future rewards by mesolimbic dopamine. *Nature Neuroscience*, 13(1), 25-27. <https://doi.org/10.1038/nn.2460>
- Garbarino, E. C., & Edell, J. A. (1997). Cognitive effort, affect, and choice. *Journal of Consumer Research*, 24(2), 147-158. <https://doi.org/10.1086/209500>
- Garnefski, N., & Kraaij, V. (2007). The Cognitive Emotion Regulation Questionnaire. *European Journal of Psychological Assessment*, 23(3), 141-149. <https://doi.org/10.1027/1015-5759.23.3.141>
- Garnefski, N., Kraaij, V., & Spinhoven, P. (2001). Negative life events, cognitive emotion regulation and emotional problems. *Personality and Individual Differences*, 30(8), 1311-1327. [https://doi.org/10.1016/S0191-8869\(00\)00113-6](https://doi.org/10.1016/S0191-8869(00)00113-6)
- Genoud, P. A. (2011). *Indice de position socioéconomique (IPSE): un calcul simplifié*. Fribourg: Université de Fribourg. Consulté à l'adresse [www.unifr.ch/ipg/assets/files/DocGenoud/IPSE.pdf](http://www.unifr.ch/ipg/assets/files/DocGenoud/IPSE.pdf)
- George, O., & Koob, G. F. (2010). Individual differences in prefrontal cortex function and the transition from drug use to drug dependence. *Neuroscience & Biobehavioral Reviews*, 35(2), 232-247. <https://doi.org/10.1016/j.neubiorev.2010.05.002>
- Gepshtein, S., Li, X., Snider, J., Plank, M., Lee, D., & Poizner, H. (2014). Dopamine function and the efficiency of human movement. *Journal of Cognitive Neuroscience*, 26(3), 645-657. [https://doi.org/10.1162/jocn\\_a\\_00503](https://doi.org/10.1162/jocn_a_00503)
- Gilbert, A. M., & Fiez, J. A. (2004). Integrating rewards and cognition in the frontal cortex. *Cognitive, Affective, & Behavioral Neuroscience*, 4(4), 540-552. <https://doi.org/10.3758/CABN.4.4.540>
- Ginty, A. T. (2013). Blunted responses to stress and reward: Reflections on biological disengagement? *International Journal of Psychophysiology*, 90(1), 90-94. <https://doi.org/10.1016/j.ijpsycho.2013.06.008>
- Glahn, D. C., Kim, J., Cohen, M. S., Poutanen, V.-P., Therman, S., Bava, S., ... Lönnqvist, J. (2002). Maintenance and manipulation in spatial working memory: Dissociations in the prefrontal cortex. *NeuroImage*, 17(1), 201-213. <https://doi.org/10.1006/nimg.2002.1161>
- Gohier, B., Ferracci, L., Surguladze, S. A., Lawrence, E., El Hage, W., Kefi, M. Z., ... Le Gall, D. (2009). Cognitive inhibition and working memory in unipolar depression. *Journal of Affective Disorders*, 116(1-2), 100-105. <https://doi.org/10.1016/j.jad.2008.10.028>
- Gold, P. W. (2015). The organization of the stress system and its dysregulation in depressive illness. *Molecular Psychiatry*, 20(1), 32-47. <https://doi.org/10.1038/mp.2014.163>
- Goldstein, D. S. (1990). Neurotransmitters and stress. *Biofeedback and Self-Regulation*, 15(3), 243-271. <https://doi.org/10.1007/BF01011108>
- Goncharova, N. D. (2013). Stress responsiveness of the Hypothalamic–Pituitary–Adrenal axis: Age-related features of the vasopressinergic regulation. *Frontiers in Endocrinology*, 4. <https://doi.org/10.3389/fendo.2013.00026>
- Goodman, F. R., Disabato, D. J., Kashdan, T. B., & Kauffman, S. B. (2018). Measuring well-being: A comparison of subjective well-being and PERMA. *The Journal of Positive Psychology*, 13(4), 321-332. <https://doi.org/10.1080/17439760.2017.1388434>
- Goodman, W. K., Janson, J., & Wolf, J. M. (2017). Meta-analytical assessment of the effects of protocol variations on cortisol responses to the Trier Social Stress Test. *Psychoneuroendocrinology*, 80, 26-35. <https://doi.org/10.1016/j.psyneuen.2017.02.030>
- Goodyer, I. M., Bacon, A., Ban, M., Croudace, T., & Herbert, J. (2009). Serotonin transporter genotype, morning cortisol and subsequent depression in adolescents. *The British Journal of Psychiatry: The Journal of Mental Science*, 195(1), 39-45. <https://doi.org/10.1192/bjp.bp.108.054775>
- Gotlib, I. H., Hamilton, J. P., Cooney, R. E., Singh, M. K., Henry, M. L., & Joormann, J. (2010). Neural processing of reward and loss in girls at risk for major depression. *Archives of General Psychiatry*, 67(4), 380. <https://doi.org/10.1001/archgenpsychiatry.2010.13>

- Gotlib, I. H., Joormann, J., & Foland-Ross, L. C. (2014). Understanding familial risk for depression: A 25-year perspective. *Perspectives on Psychological Science: A Journal of the Association for Psychological Science*, 9(1), 94-108. <https://doi.org/10.1177/1745691613513469>
- Gottfried, J. A., O'Doherty, J. P., & Dolan, R. J. (2003). Encoding predictive reward value in human amygdala and orbitofrontal cortex. *Science (New York, N.Y.)*, 301(5636), 1104-1107. <https://doi.org/10.1126/science.1087919>
- Grabenhorst, F., & Rolls, E. T. (2011). Value, pleasure and choice in the ventral prefrontal cortex. *Trends in Cognitive Sciences*, 15(2), 56-67. <https://doi.org/10.1016/j.tics.2010.12.004>
- Grahn, J. A., Parkinson, J. A., & Owen, A. M. (2008). The cognitive functions of the caudate nucleus. *Progress in Neurobiology*, 86(3), 141-155. <https://doi.org/10.1016/j.pneurobio.2008.09.004>
- Grant, M. M., Thase, M. E., & Sweeney, J. A. (2001). Cognitive disturbance in outpatient depressed younger adults: Evidence of modest impairment. *Biological Psychiatry*, 50(1), 35-43. [https://doi.org/10.1016/S0006-3223\(00\)01072-6](https://doi.org/10.1016/S0006-3223(00)01072-6)
- Greenberg, N. (2002). Causes and consequences of stress. *Integrative and Comparative Biology*, 42(3), 508-516. <https://doi.org/10.1093/icb/42.3.508>
- Grill, H. J., & Norgren, R. (1978). The taste reactivity test. I. Mimetic responses to gustatory stimuli in neurologically normal rats. *Brain Research*, 143(2), 263-279. [https://doi.org/10.1016/0006-8993\(78\)90568-1](https://doi.org/10.1016/0006-8993(78)90568-1)
- Grillon, C. (2008). Models and mechanisms of anxiety: Evidence from startle studies. *Psychopharmacology*, 199(3), 421-437. <https://doi.org/10.1007/s00213-007-1019-1>
- Grillon, C., & Ameli, R. (1998). Effects of threat of shock, shock electrode placement and darkness on startle. *International Journal of Psychophysiology*, 28(3), 223-231. [https://doi.org/10.1016/S0167-8760\(97\)00072-X](https://doi.org/10.1016/S0167-8760(97)00072-X)
- Grillon, C., Ameli, R., Foot, M., & Davis, M. (1993). Fear-potentiated startle: Relationship to the level of state/trait anxiety in healthy subjects. *Biological Psychiatry*, 33(8-9), 566-574.
- Grillon, C., & Baas, J. (2003). A review of the modulation of the startle reflex by affective states and its application in psychiatry. *Clinical Neurophysiology: Official Journal of the International Federation of Clinical Neurophysiology*, 114(9), 1557-1579.
- Gross, J. J. (1998). The emerging field of emotion regulation: An integrative review. *Review of General Psychology*, 2(3), 271-299. <https://doi.org/10.1037/1089-2680.2.3.271>
- Gross, J. J. (1999). Emotion regulation: Past, present, future. *Cognition & Emotion*, 13(5), 551-573. <https://doi.org/10.1080/026999399379186>
- Gross, J. J. (2002). Emotion regulation: Affective, cognitive, and social consequences. *Psychophysiology*, 39(3), 281-291. <https://doi.org/10.1017/S0048577201393198>
- Gross, J. J. (2015). Emotion regulation: Current status and future prospects. *Psychological Inquiry*, 26(1), 1-26. <https://doi.org/10.1080/1047840X.2014.940781>
- Gross, J. J., & Jazaieri, H. (2014). Emotion, emotion regulation, and psychopathology: An affective science perspective. *Clinical Psychological Science*, 2(4), 387-401. <https://doi.org/10.1177/2167702614536164>
- Gross, J. J., Sheppes, G., & Urry, H. L. (2011). Emotion generation and emotion regulation: A distinction we should make (carefully). *Cognition and Emotion*, 25(5), 765-781.
- Gross, J. J., & Thompson, R. A. (2007). Emotion regulation: Conceptual foundations. In J. J. Gross (Éd.), *Handbook of emotion regulation* (p. 3-24). New-York: Guilford Press.
- Grynderup, M. B., Kolstad, H. A., Mikkelsen, S., Andersen, J. H., Bonde, J. P., Buttenschøn, H. N., ... Hansen, Å. M. (2013). A two-year follow-up study of salivary cortisol concentration and the risk of depression. *Psychoneuroendocrinology*, 38(10), 2042-2050. <https://doi.org/10.1016/j.psyneuen.2013.03.013>
- Gu, X., Hof, P. R., Friston, K. J., & Fan, J. (2013). Anterior insular cortex and emotional awareness: Anterior insular cortex and emotional awareness. *Journal of Comparative Neurology*, 521(15), 3371-3388. <https://doi.org/10.1002/cne.23368>

- Guilod, M., Gaillard, C., Recabarren, R. E., Schoebi, D., Gomez, P., Horsch, A., ... Martin-Soelch, C. (2019). *Objective and subjective dimensions of reward and stress experiences: Correlations between fMRI and daily life self-reported data*. Consulté à l'adresse <http://rgdoi.net/10.13140/RG.2.2.33571.91683>
- Gunnar, M. R., Talge, N. M., & Herrera, A. (2009). Stressor paradigms in developmental studies: What does and does not work to produce mean increases in salivary cortisol. *Psychoneuroendocrinology*, *34*(7), 953-967. <https://doi.org/10.1016/j.psychneuen.2009.02.010>
- Haber, S. N. (2003). The primate basal ganglia: Parallel and integrative networks. *Journal of Chemical Neuroanatomy*, *26*(4), 317-330. <https://doi.org/10.1016/j.jchemneu.2003.10.003>
- Haber, S. N. (2011). Neuroanatomy of reward: A view from the ventral striatum. In J. A. Gottfried (Éd.), *Neurobiology of Sensation and Reward*. Boca Raton (FL): CRC Press/Taylor & Francis.
- Haber, S. N., Kim, K.-S., Maily, P., & Calzavara, R. (2006). Reward-related cortical inputs define a large striatal region in primates that interface with associative cortical connections, providing a substrate for incentive-based learning. *Journal of Neuroscience*, *26*(32), 8368-8376. <https://doi.org/10.1523/JNEUROSCI.0271-06.2006>
- Haber, S. N., & Knutson, B. (2010). The reward circuit: Linking primate anatomy and human imaging. *Neuropsychopharmacology*, *35*(1), 4-26. <https://doi.org/10.1038/npp.2009.129>
- Hägele, C., Schlagenhaut, F., Rapp, M., Sterzer, P., Beck, A., Bermpohl, F., ... Heinz, A. (2015). Dimensional psychiatry: Reward dysfunction and depressive mood across psychiatric disorders. *Psychopharmacology*, *232*(2), 331-341. <https://doi.org/10.1007/s00213-014-3662-7>
- Hakymez, H. S., Dagher, A., Smith, S. D., & Zald, D. H. (2008). Striatal dopamine transmission in healthy humans during a passive monetary reward task. *NeuroImage*, *39*(4), 2058-2065. <https://doi.org/10.1016/j.neuroimage.2007.10.034>
- Hale, M. W., & Lowry, C. A. (2015). Brain monoaminergic systems in stress neuroendocrinology. In J. Russell & M. Shipston (Éd.), *Neuroendocrinology of Stress* (p. 19-42). <https://doi.org/10.1002/9781118921692.ch2>
- Hammen, C. L. (1991). Generation of stress in the course of unipolar depression. *Journal of Abnormal Psychology*, *100*(4), 555-561.
- Hammen, C. L. (2005). Stress and depression. *Annual Review of Clinical Psychology*, *1*, 293-319. <https://doi.org/10.1146/annurev.clinpsy.1.102803.143938>
- Hammen, C. L., Dalton, E. D., & Thompson, S. M. (2015). Measurement of chronic stress. In R. L. Cautin & S. O. Lilienfeld (Éd.), *The Encyclopedia of Clinical Psychology* (p. 1-7). <https://doi.org/10.1002/9781118625392.wbecp047>
- Hammen, C. L., Kim, E. Y., Eberhart, N. K., & Brennan, P. A. (2009). Chronic and acute stress and the prediction of major depression in women. *Depression and Anxiety*, *26*(8), 718-723. <https://doi.org/10.1002/da.20571>
- Handwerker, K. (2009). Differential patterns of HPA activity and reactivity in adult posttraumatic stress disorder and major depressive disorder. *Harvard Review of Psychiatry*, *17*(3), 184-205. <https://doi.org/10.1080/10673220902996775>
- Hanson, J. L., Hariri, A. R., & Williamson, D. E. (2015). Blunted ventral striatum development in adolescence reflects emotional neglect and predicts depressive symptoms. *Biological Psychiatry*, *78*(9), 598-605. <https://doi.org/10.1016/j.biopsych.2015.05.010>
- Hanssen, E., van der Velde, J., Gromann, P. M., Shergill, S. S., de Haan, L., Bruggeman, R., ... van Atteveldt, N. (2015). Neural correlates of reward processing in healthy siblings of patients with schizophrenia. *Frontiers in Human Neuroscience*, *9*, 504. <https://doi.org/10.3389/fnhum.2015.00504>
- Hare, T. A., Camerer, C. F., & Rangel, A. (2009). Self-control in decision-making involves modulation of the vmPFC valuation system. *Science*, *324*(5927), 646-648. <https://doi.org/10.1126/science.1168450>
- Harvey, P.-O., Pruessner, J., Czechowska, Y., & Lepage, M. (2007). Individual differences in trait anhedonia: A structural and functional magnetic resonance imaging study in non-clinical subjects. *Molecular Psychiatry*, *12*(8), 767-775. <https://doi.org/10.1038/sj.mp.4002021>
- Hasler, G. (2010). Pathophysiology of depression: Do we have any solid evidence of interest to clinicians? *World Psychiatry*, *9*(3), 155-161. <https://doi.org/10.1002/j.2051-5545.2010.tb00298.x>



- Hasler, G., Drevets, W. C., Manji, H. K., & Charney, D. S. (2004). Discovering endophenotypes for major depression. *Neuropsychopharmacology*, *29*(10), 1765-1781. <https://doi.org/10.1038/sj.npp.1300506>
- Hasler, G., & Northoff, G. (2011). Discovering imaging endophenotypes for major depression. *Molecular Psychiatry*, *16*(6), 604-619. <https://doi.org/10.1038/mp.2011.23>
- Hassan, A., & Benarroch, E. E. (2015). Heterogeneity of the midbrain dopamine system: Implications for Parkinson disease. *Neurology*, *85*(20), 1795-1805. <https://doi.org/10.1212/WNL.0000000000002137>
- Hassani, O. K., Cromwell, H. C., & Schultz, W. (2001). Influence of expectation of different rewards on behavior-related neuronal activity in the striatum. *Journal of Neurophysiology*, *85*(6), 2477-2489. <https://doi.org/10.1152/jn.2001.85.6.2477>
- Hayden, B. Y., Pearson, J. M., & Platt, M. L. (2009). Fictive reward signals in the anterior cingulate cortex. *Science*, *324*(5929), 948-950. <https://doi.org/10.1126/science.1168488>
- Heatherington, T. F., & Wagner, D. D. (2011). Cognitive neuroscience of self-regulation failure. *Trends in Cognitive Sciences*, *15*(3), 132-139. <https://doi.org/10.1016/j.tics.2010.12.005>
- Heim, C., & Binder, E. B. (2012). Current research trends in early life stress and depression: Review of human studies on sensitive periods, gene-environment interactions, and epigenetics. *Experimental Neurology*, *233*(1), 102-111. <https://doi.org/10.1016/j.expneurol.2011.10.032>
- Heim, C., & Nemeroff, C. B. (2001). The role of childhood trauma in the neurobiology of mood and anxiety disorders: Preclinical and clinical studies. *Biological Psychiatry*, *49*(12), 1023-1039.
- Heller, A. S., Fox, A. S., Wing, E. K., McQuisition, K. M., Vack, N. J., & Davidson, R. J. (2015). The neurodynamics of affect in the laboratory predicts persistence of real-world emotional responses. *The Journal of Neuroscience: The Official Journal of the Society for Neuroscience*, *35*(29), 10503-10509. <https://doi.org/10.1523/JNEUROSCI.0569-15.2015>
- Henckens, M. J. A. G., Hermans, E. J., Pu, Z., Joëls, M., & Fernández, G. (2009). Stressed memories: How acute stress affects memory formation in humans. *The Journal of Neuroscience: The Official Journal of the Society for Neuroscience*, *29*(32), 10111-10119. <https://doi.org/10.1523/JNEUROSCI.1184-09.2009>
- Henckens, M. J. A. G., van Wingen, G. A., Joëls, M., & Fernández, G. (2012). Time-dependent effects of cortisol on selective attention and emotional interference: A functional MRI study. *Frontiers in Integrative Neuroscience*, *6*. <https://doi.org/10.3389/fnint.2012.00066>
- Henn, F. A., & Vollmayr, B. (2005). Stress models of depression: Forming genetically vulnerable strains. *Neuroscience and Biobehavioral Reviews*, *29*(4-5), 799-804. <https://doi.org/10.1016/j.neubiorev.2005.03.019>
- Herman, J. P., Ostrander, M. M., Mueller, N. K., & Figueiredo, H. (2005). Limbic system mechanisms of stress regulation: Hypothalamo-pituitary-adrenocortical axis. *Progress in Neuro-Psychopharmacology and Biological Psychiatry*, *29*(8), 1201-1213. <https://doi.org/10.1016/j.pnpbp.2005.08.006>
- Hermans, E. J., Henckens, M. J. A. G., Joëls, M., & Fernández, G. (2014). Dynamic adaptation of large-scale brain networks in response to acute stressors. *Trends in Neurosciences*, *37*(6), 304-314. <https://doi.org/10.1016/j.tins.2014.03.006>
- Horvitz, J. C. (2002). Dopamine gating of glutamatergic sensorimotor and incentive motivational input signals to the striatum. *Behavioural Brain Research*, *137*(1-2), 65-74.
- Hubbard, N. A., Hutchison, J. L., Hambrick, D. Z., & Rypma, B. (2016). The enduring effects of depressive thoughts on working memory. *Journal of Affective Disorders*, *190*, 208-213. <https://doi.org/10.1016/j.jad.2015.06.056>
- Hull, C. L. (1943). *Principles of behavior*. New York, NY, USA: Appleton-Century.
- Ikemoto, S., & Panksepp, J. (1999). The role of nucleus accumbens dopamine in motivated behavior: A unifying interpretation with special reference to reward-seeking. *Brain Research. Brain Research Reviews*, *31*(1), 6-41.
- Ingram, R. E., & Luxton, D. D. (2005). *Development of psychopathology: A vulnerability-stress perspective*. <https://doi.org/10.4135/9781452231655>
- Inzlicht, M., Bartholow, B. D., & Hirsh, J. B. (2015). Emotional foundations of cognitive control. *Trends in Cognitive Sciences*, *19*(3), 126-132. <https://doi.org/10.1016/j.tics.2015.01.004>

- Ironside, M., Kumar, P., Kang, M.-S., & Pizzagalli, D. A. (2018). Brain mechanisms mediating effects of stress on reward sensitivity. *Current Opinion in Behavioral Sciences*, 22, 106-113. <https://doi.org/10.1016/j.cobeha.2018.01.016>
- Izuma, K., Saito, D. N., & Sadato, N. (2008). Processing of social and monetary rewards in the human striatum. *Neuron*, 58(2), 284-294. <https://doi.org/10.1016/j.neuron.2008.03.020>
- Jermann, F., Van der Linden, M., d'Acremont, M., & Zermatten, A. (2006). Cognitive Emotion Regulation Questionnaire (CERQ). *European Journal of Psychological Assessment*, 22(2), 126-131. <https://doi.org/10.1027/1015-5759.22.2.126>
- Joormann, J., & Stanton, C. H. (2016). Examining emotion regulation in depression: A review and future directions. *Behaviour Research and Therapy*, 86, 35-49. <https://doi.org/10.1016/j.brat.2016.07.007>
- Joseph, M. H., Datla, K., & Young, A. M. J. (2003). The interpretation of the measurement of nucleus accumbens dopamine by in vivo dialysis: The kick, the craving or the cognition? *Neuroscience & Biobehavioral Reviews*, 27(6), 527-541. <https://doi.org/10.1016/j.neubiorev.2003.09.001>
- Kable, J. W., & Glimcher, P. W. (2007). The neural correlates of subjective value during intertemporal choice. *Nature Neuroscience*, 10(12), 1625-1633. <https://doi.org/10.1038/nn2007>
- Kahneman, D. (1973). *Attention and effort*. Englewood Cliffs, N.J: Prentice-Hall.
- Kahneman, D., & Tversky, A. (1982). The psychology of preferences. *Scientific American*, 246(1), 160-173. Consulté à l'adresse JSTOR.
- Kajantie, E., & Phillips, D. (2006). The effects of sex and hormonal status on the physiological response to acute psychosocial stress. *Psychoneuroendocrinology*, 31(2), 151-178. <https://doi.org/10.1016/j.psyneuen.2005.07.002>
- Karg, K., Burmeister, M., Shedden, K., & Sen, S. (2011). The serotonin transporter promoter variant (5-HTTLPR), stress, and depression meta-analysis revisited: Evidence of genetic moderation. *Archives of General Psychiatry*, 68(5), 444-454. <https://doi.org/10.1001/archgenpsychiatry.2010.189>
- Keating, C., Tilbrook, A. J., Rossell, S. L., Enticott, P. G., & Fitzgerald, P. B. (2012). Reward processing in anorexia nervosa. *Neuropsychologia*, 50(5), 567-575. <https://doi.org/10.1016/j.neuropsychologia.2012.01.036>
- Keller, M. C., Neale, M. C., & Kendler, K. S. (2007). Association of different adverse life events with distinct patterns of depressive symptoms. *American Journal of Psychiatry*, 164(10), 1521-1529. <https://doi.org/10.1176/appi.ajp.2007.06091564>
- Kemeny, M. E. (2003). The psychobiology of stress. *Current Directions in Psychological Science*, 12(4), 124-129. <https://doi.org/10.1111/1467-8721.01246>
- Kendler, K. S., & Gardner, C. O. (2016). Depressive vulnerability, stressful life events and episode onset of major depression: A longitudinal model. *Psychological Medicine*, 46(09), 1865-1874. <https://doi.org/10.1017/S0033291716000349>
- Kendler, K. S., Karkowski, L. M., & Prescott, C. A. (1999). Causal relationship between stressful life events and the onset of major depression. *The American Journal of Psychiatry*, 156(6), 837-841. <https://doi.org/10.1176/ajp.156.6.837>
- Kendler, K. S., & Karkowski-Shuman, L. (1997). Stressful life events and genetic liability to major depression: Genetic control of exposure to the environment? *Psychological Medicine*, 27(3), 539-547. <https://doi.org/10.1017/S0033291797004716>
- Kendler, K. S., Thornton, L. M., & Prescott, C. A. (2001). Gender differences in the rates of exposure to stressful life events and sensitivity to their depressogenic effects. *American Journal of Psychiatry*, 158(4), 587-593. <https://doi.org/10.1176/appi.ajp.158.4.587>
- Kennerley, S. W., & Wallis, J. D. (2009). Encoding of reward and space during a working memory task in the orbitofrontal cortex and anterior cingulate sulcus. *Journal of Neurophysiology*, 102(6), 3352-3364. <https://doi.org/10.1152/jn.00273.2009>
- Kerestes, R., Davey, C. G., Stephanou, K., Whittle, S., & Harrison, B. J. (2014). Functional brain imaging studies of youth depression: A systematic review. *NeuroImage: Clinical*, 4, 209-231. <https://doi.org/10.1016/j.nicl.2013.11.009>
- Kim, S. H., & Hamann, S. (2007). Neural correlates of positive and negative emotion regulation. *Journal of Cognitive Neuroscience*, 19(5), 776-798. <https://doi.org/10.1162/jocn.2007.19.5.776>

- Kirschbaum, C., Kudielka, B. M., Gaab, J., Schommer, N. C., & Hellhammer, D. H. (1999). Impact of gender, menstrual cycle phase, and oral contraceptives on the activity of the hypothalamus-pituitary-adrenal axis. *Psychosomatic Medicine*, *61*(2), 154-162.
- Kirschbaum, C., Pirke, K.-M., & Hellhammer, D. H. (1993). The 'Trier Social Stress Test' – A tool for investigating psychobiological stress responses in a laboratory setting. *Neuropsychobiology*, *28*(1-2), 76-81. <https://doi.org/10.1159/000119004>
- Kleen, J. K., Sitomer, M. T., Killeen, P. R., & Conrad, C. D. (2006). Chronic stress impairs spatial memory and motivation for reward without disrupting motor ability and motivation to explore. *Behavioral Neuroscience*, *120*(4), 842-851. <https://doi.org/10.1037/0735-7044.120.4.842>
- Klein-Flügge, M. C., Kennerley, S. W., Saraiva, A. C., Penny, W. D., & Bestmann, S. (2015). Behavioral modeling of human choices reveals dissociable effects of physical effort and temporal delay on reward devaluation. *PLoS Computational Biology*, *11*(3), e1004116. <https://doi.org/10.1371/journal.pcbi.1004116>
- Knutson, B., Adams, C. M., Fong, G. W., & Hommer, D. (2001). Anticipation of increasing monetary reward selectively recruits nucleus accumbens. *The Journal of Neuroscience: The Official Journal of the Society for Neuroscience*, *21*(16), RC159.
- Knutson, B., & Greer, S. M. (2008). Anticipatory affect: Neural correlates and consequences for choice. *Philosophical Transactions of the Royal Society B: Biological Sciences*, *363*(1511), 3771-3786. <https://doi.org/10.1098/rstb.2008.0155>
- Knutson, B., Westdorp, A., Kaiser, E., & Hommer, D. (2000). fMRI visualization of brain activity during a Monetary Incentive Delay Task. *NeuroImage*, *12*(1), 20-27. <https://doi.org/10.1006/nimg.2000.0593>
- Kogler, L., Müller, V. I., Chang, A., Eickhoff, S. B., Fox, P. T., Gur, R. C., & Derntl, B. (2015). Psychosocial versus physiological stress — Meta-analyses on deactivations and activations of the neural correlates of stress reactions. *NeuroImage*, *119*, 235-251. <https://doi.org/10.1016/j.neuroimage.2015.06.059>
- Kohn, N., Eickhoff, S. B., Scheller, M., Laird, A. R., Fox, P. T., & Habel, U. (2014). Neural network of cognitive emotion regulation — An ALE meta-analysis and MACM analysis. *NeuroImage*, *87*, 345-355. <https://doi.org/10.1016/j.neuroimage.2013.11.001>
- Koob, G. F. (2008). A role for brain stress systems in addiction. *Neuron*, *59*(1), 11-34. <https://doi.org/10.1016/j.neuron.2008.06.012>
- Koob, G. F. (2010). The role of CRF and CRF-related peptides in the dark side of addiction. *Brain Research*, *1314*, 3-14. <https://doi.org/10.1016/j.brainres.2009.11.008>
- Koob, G. F. (2013). Addiction is a reward deficit and stress surfeit disorder. *Frontiers in Psychiatry*, *4*, 72-100. <https://doi.org/10.3389/fpsy.2013.00072>
- Koob, G. F., & Le Moal, M. (2001). Drug addiction, dysregulation of reward, and allostasis. *Neuropsychopharmacology*, *24*(2), 97-129. [https://doi.org/10.1016/S0893-133X\(00\)00195-0](https://doi.org/10.1016/S0893-133X(00)00195-0)
- Koob, G. F., & Le Moal, M. (2008). Addiction and the brain antireward system. *Annual Review of Psychology*, *59*(1), 29-53. <https://doi.org/10.1146/annurev.psych.59.103006.093548>
- Koob, G. F., & Volkow, N. D. (2010). Neurocircuitry of addiction. *Neuropsychopharmacology*, *35*(1), 217-238. <https://doi.org/10.1038/npp.2009.110>
- Kool, W., McGuire, J. T., Rosen, Z. B., & Botvinick, M. M. (2010). Decision making and the avoidance of cognitive demand. *Journal of Experimental Psychology: General*, *139*(4), 665-682. <https://doi.org/10.1037/a0020198>
- Koolhaas, J. M., Bartolomucci, A., Buwalda, B., de Boer, S. F., Flügge, G., Korte, S. M., ... Fuchs, E. (2011). Stress revisited: A critical evaluation of the stress concept. *Neuroscience & Biobehavioral Reviews*, *35*(5), 1291-1301. <https://doi.org/10.1016/j.neubiorev.2011.02.003>
- Kovács, K. J. (2013). CRH: The link between hormonal-, metabolic- and behavioral responses to stress. *Journal of Chemical Neuroanatomy*, *54*, 25-33. <https://doi.org/10.1016/j.jchemneu.2013.05.003>
- Krawczyk, D. C., & D'Esposito, M. (2013). Modulation of working memory function by motivation through loss-aversion. *Human Brain Mapping*, *34*(4), 762-774. <https://doi.org/10.1002/hbm.21472>
- Krigolson, O. E., Hassall, C. D., Satel, J., & Klein, R. M. (2015). The impact of cognitive load on reward evaluation. *Brain Research*, *1627*, 225-232. <https://doi.org/10.1016/j.brainres.2015.09.028>

- Kringelbach, M. L. (2003). Activation of the human orbitofrontal cortex to a liquid food stimulus is correlated with its subjective pleasantness. *Cerebral Cortex*, *13*(10), 1064-1071. <https://doi.org/10.1093/cercor/13.10.1064>
- Kringelbach, M. L. (2005). The human orbitofrontal cortex: Linking reward to hedonic experience. *Nature Reviews Neuroscience*, *6*(9), 691-702. <https://doi.org/10.1038/nrn1747>
- Kringelbach, M. L. (2007). Emotion, feelings and hedonics in the human brain. In *The emotions: A cultural reader* (p. 37-60). Berg Publishers.
- Kringelbach, M. L., & Berridge, K. C. (Éd.). (2009). *Pleasures of the brain*. New York: Oxford University Press.
- Kringelbach, M. L., & Berridge, K. C. (2010). The neuroscience of happiness and pleasure. *Social Research*, *77*(2), 659-678.
- Kringelbach, M. L., & Berridge, K. C. (2017). The affective core of emotion: Linking pleasure, subjective well-being, and optimal metastability in the brain. *Emotion Review*, *9*(3), 191-199. <https://doi.org/10.1177/1754073916684558>
- Kroemer, N. B., Guevara, A., Ciocanea Teodorescu, I., Wuttig, F., Kobiella, A., & Smolka, M. N. (2014). Balancing reward and work: Anticipatory brain activation in NAcc and VTA predict effort differentially. *NeuroImage*, *102*, 510-519. <https://doi.org/10.1016/j.neuroimage.2014.07.060>
- Kudielka, B. M., Hellhammer, D. H., & Wüst, S. (2009). Why do we respond so differently? Reviewing determinants of human salivary cortisol responses to challenge. *Psychoneuroendocrinology*, *34*(1), 2-18. <https://doi.org/10.1016/j.psyneuen.2008.10.004>
- Kudielka, B. M., & Kirschbaum, C. (2005). Sex differences in HPA axis responses to stress: A review. *Biological Psychology*, *69*(1), 113-132. <https://doi.org/10.1016/j.biopsycho.2004.11.009>
- Kühn, S., & Gallinat, J. (2012). The neural correlates of subjective pleasantness. *NeuroImage*, *61*(1), 289-294. <https://doi.org/10.1016/j.neuroimage.2012.02.065>
- Kujawa, A., & Burkhouse, K. L. (2017). Vulnerability to depression in youth: Advances from affective neuroscience. *Biological Psychiatry: Cognitive Neuroscience and Neuroimaging*, *2*(1), 28-37. <https://doi.org/10.1016/j.bpsc.2016.09.006>
- Kumar, P., Berghorst, L. H., Nickerson, L. D., Dutra, S. J., Goer, F. K., Greve, D. N., & Pizzagalli, D. A. (2014). Differential effects of acute stress on anticipatory and consummatory phases of reward processing. *Neuroscience*, *266*, 1-12. <https://doi.org/10.1016/j.neuroscience.2014.01.058>
- Kumar, P., Waiter, G., Ahearn, T., Milders, M., Reid, I., & Steele, J. D. (2008). Abnormal temporal difference reward-learning signals in major depression. *Brain: A Journal of Neurology*, *131*(Pt 8), 2084-2093. <https://doi.org/10.1093/brain/awn136>
- Kurniawan, I. T. (2011). Dopamine and effort-based decision making. *Frontiers in Neuroscience*, *5*. <https://doi.org/10.3389/fnins.2011.00081>
- Kurniawan, I. T., Seymour, B., Talmi, D., Yoshida, W., Chater, N., & Dolan, R. J. (2010). Choosing to make an effort: The role of striatum in signaling physical effort of a chosen action. *Journal of Neurophysiology*, *104*(1), 313-321. <https://doi.org/10.1152/jn.00027.2010>
- Landau, S. M., Lal, R., O'Neil, J. P., Baker, S., & Jagust, W. J. (2009). Striatal dopamine and working memory. *Cerebral Cortex*, *19*(2), 445-454. <https://doi.org/10.1093/cercor/bhn095>
- Lang, P. J., Bradley, M. M., & Cuthbert, B. N. (2008). *International Affective Picture System (IAPS): Affective ratings of pictures and instruction manual (Rep. No. A-8)*.
- Lang, P. J., Davis, M., & Öhman, A. (2000). Fear and anxiety: Animal models and human cognitive psychophysiology. *Journal of Affective Disorders*, *61*(3), 137-159. [https://doi.org/10.1016/S0165-0327\(00\)00343-8](https://doi.org/10.1016/S0165-0327(00)00343-8)
- LeDoux, J. E. (2012). Rethinking the emotional brain. *Neuron*, *73*(4), 653-676. <https://doi.org/10.1016/j.neuron.2012.02.004>
- LeDoux, J. E., & Pine, D. S. (2016). Using neuroscience to help understand fear and anxiety: A two-system framework. *American Journal of Psychiatry*, *173*(11), 1083-1093. <https://doi.org/10.1176/appi.ajp.2016.16030353>
- Lee, S. W., Shimojo, S., & O'Doherty, J. P. (2014). Neural computations underlying arbitration between model-based and model-free learning. *Neuron*, *81*(3), 687-699. <https://doi.org/10.1016/j.neuron.2013.11.028>

- Leppänen, J. M. (2006). Emotional information processing in mood disorders: A review of behavioral and neuroimaging findings. *Current Opinion in Psychiatry*, 19(1), 34-39. <https://doi.org/10.1097/01.yco.0000191500.46411.00>
- Levy, D. J., & Glimcher, P. W. (2012). The root of all value: A neural common currency for choice. *Current Opinion in Neurobiology*, 22(6), 1027-1038. <https://doi.org/10.1016/j.conb.2012.06.001>
- Lewinsohn, P. M., Allen, N. B., Seeley, J. R., & Gotlib, I. H. (1999). First onset versus recurrence of depression: Differential processes of psychosocial risk. *Journal of Abnormal Psychology*, 108(3), 483-489.
- Lewis, A. H., Porcelli, A. J., & Delgado, M. R. (2014). The effects of acute stress exposure on striatal activity during Pavlovian conditioning with monetary gains and losses. *Frontiers in Behavioral Neuroscience*, 8. <https://doi.org/10.3389/fnbeh.2014.00179>
- Leyton, M., Young, S. N., & Benkelfat, C. (2007). Mood-elevating effects of d-amphetamine and incentive salience: The effect of acute dopamine precursor depletion. *J Psychiatry Neurosci*, 8.
- Lin, D., Buijnzeel, A. W., Schmidt, P., & Markou, A. (2002). Exposure to chronic mild stress alters thresholds for lateral hypothalamic stimulation reward and subsequent responsiveness to amphetamine. *Neuroscience*, 114(4), 925-933. [https://doi.org/10.1016/S0306-4522\(02\)00366-4](https://doi.org/10.1016/S0306-4522(02)00366-4)
- Liu, R. T., & Alloy, L. B. (2010). Stress generation in depression: A systematic review of the empirical literature and recommendations for future study. *Clinical Psychology Review*, 30(5), 582-593. <https://doi.org/10.1016/j.cpr.2010.04.010>
- Liu, R. T., Alloy, L. B., Mastin, B. M., Choi, J. Y., Boland, E. M., & Jenkins, A. (2014). Vulnerability-specific stress generation: An examination of depressogenic cognitive vulnerability across multiple domains. *Anxiety, Stress, & Coping*, 27(6), 695-711. <https://doi.org/10.1080/10615806.2014.909927>
- Liu, W., Roiser, J. P., Wang, L., Zhu, Y., Huang, J., Neumann, D. L., ... Chan, R. C. K. (2016). Anhedonia is associated with blunted reward sensitivity in first-degree relatives of patients with major depression. *Journal of Affective Disorders*, 190, 640-648. <https://doi.org/10.1016/j.jad.2015.10.050>
- Liu, Xinxin, Iwanaga, K., Shimomura, Y., & Katsuura, T. (2007). Comparison of stress responses between mental tasks and white noise exposure. *Journal of Physiological Anthropology*, 26(2), 165-171. <https://doi.org/10.2114/jpa2.26.165>
- Liu, Xun, Hairston, J., Schrier, M., & Fan, J. (2011). Common and distinct networks underlying reward valence and processing stages: A meta-analysis of functional neuroimaging studies. *Neuroscience & Biobehavioral Reviews*, 35(5), 1219-1236. <https://doi.org/10.1016/j.neubiorev.2010.12.012>
- Loewenstein, G. (2000). Emotions in economic theory and economic behavior. *The American Economic Review*, 90(2), 426-432.
- Lopez-Duran, N. L., Kovacs, M., & George, C. J. (2009). Hypothalamic-pituitary-adrenal axis dysregulation in depressed children and adolescents: A meta-analysis. *Psychoneuroendocrinology*, 34(9), 1272-1283. <https://doi.org/10.1016/j.psyneuen.2009.03.016>
- Lovallo, W. (1975). The Cold Pressor Test and autonomic function: A review and integration. *Psychophysiology*, 12(3), 268-282. <https://doi.org/10.1111/j.1469-8986.1975.tb01289.x>
- Lovallo, W., & Thomas, T. L. (2017). Stress hormones in psychophysiological research: Emotional, behavioral, and cognitive implications. In J. T. Cacioppo, L. G. Tassinary, & G. G. Berntson (Eds.), *Handbook of psychophysiology* (Cambridge University Press, p. 342-367). New York, NY, US.
- Luethi, M. (2008). Stress effects on working memory, explicit memory, and implicit memory for neutral and emotional stimuli in healthy men. *Frontiers in Behavioral Neuroscience*, 2. <https://doi.org/10.3389/neuro.08.005.2008>
- Luking, K. R., Pagliaccio, D., Luby, J. L., & Barch, D. M. (2016). Reward processing and risk for depression across development. *Trends in Cognitive Sciences*, 20(6), 456-468. <https://doi.org/10.1016/j.tics.2016.04.002>
- Lupien, S. J., McEwen, B. S., Gunnar, M. R., & Heim, C. (2009). Effects of stress throughout the lifespan on the brain, behaviour and cognition. *Nature Reviews Neuroscience*, 10(6), 434-445. <https://doi.org/10.1038/nrn2639>
- Lutz, K., & Widmer, M. (2014). What can the monetary incentive delay task tell us about the neural processing of reward and punishment? *Neuroscience and Neuroeconomics*, 33. <https://doi.org/10.2147/NAN.S38864>

- Macoveanu, J., Knorr, U., Skimminge, A., Søndergaard, M. G., Jørgensen, A., Fauerholdt-Jepsen, M., ... Kessing, L. V. (2014). Altered reward processing in the orbitofrontal cortex and hippocampus in healthy first-degree relatives of patients with depression. *Psychological Medicine*, *44*(06), 1183-1195. <https://doi.org/10.1017/S0033291713001815>
- Madan, C. R. (2013). Toward a common theory for learning from reward, affect, and motivation: The SIMON framework. *Frontiers in Systems Neuroscience*, *7*(59), 1-6. <https://doi.org/10.3389/fnsys.2013.00059>
- Mahler, S. V., Smith, K. S., & Berridge, K. C. (2007). Endocannabinoid hedonic hotspot for sensory pleasure: Anandamide in nucleus accumbens shell enhances 'liking' of a sweet reward. *Neuropsychopharmacology*, *32*(11), 2267-2278. <https://doi.org/10.1038/sj.npp.1301376>
- Maier, S. F., Amat, J., Baratta, M. V., Paul, E., & Watkins, L. R. (2006). Behavioral control, the medial prefrontal cortex, and resilience. *Dialogues in Clinical Neuroscience*, *8*(4), 397-406.
- Maier, S. U., Makwana, A. B., & Hare, T. A. (2015). Acute stress impairs self-control in goal-directed choice by altering multiple functional connections within the brain's decision circuits. *Neuron*, *87*(3), 621-631. <https://doi.org/10.1016/j.neuron.2015.07.005>
- Malvaez, M., & Wassum, K. M. (2018). Regulation of habit formation in the dorsal striatum. *Current Opinion in Behavioral Sciences*, *20*, 67-74. <https://doi.org/10.1016/j.cobeha.2017.11.005>
- Mangiavacchi, S., Masi, F., Scheggi, S., Leggio, B., De Montis, M. G., & Gambarana, C. (2002). Long-term behavioral and neurochemical effects of chronic stress exposure in rats: Dopamine and 5-HT output after chronic stress. *Journal of Neurochemistry*, *79*(6), 1113-1121. <https://doi.org/10.1046/j.1471-4159.2001.00665.x>
- Manohar, S. G., Finzi, R. D., Drew, D., & Husain, M. (2017). Distinct motivational effects of contingent and noncontingent rewards. *Psychological Science*, *28*(7), 1016-1026. <https://doi.org/10.1177/0956797617693326>
- Marazziti, D., Consoli, G., Picchetti, M., Carlini, M., & Faravelli, L. (2010). Cognitive impairment in major depression. *European Journal of Pharmacology*, *626*(1), 83-86. <https://doi.org/10.1016/j.ejphar.2009.08.046>
- Marks, L. E. (2011). A brief history of sensation and reward. In *Frontiers in Neuroscience. Neurobiology of Sensation and Reward* (p. 15-44). Boca Raton, FL, USA: CRC Press/Taylor & Francis.
- Martin-Soelch, C. (2009). Is depression associated with dysfunction of the central reward system? *Biochemical Society Transactions*, *37*(1), 313-317. <https://doi.org/10.1042/BST0370313>
- Martin-Soelch, C. (2013). Neuroadaptive changes associated with smoking: Structural and functional neural changes in nicotine dependence. *Brain Sciences*, *3*(1), 159-176. <https://doi.org/10.3390/brainsci3010159>
- Martin-Soelch, C., Kobel, M., Stoecklin, M., Michael, T., Weber, S., Krebs, B., & Opwis, K. (2009). Reduced response to reward in smokers and cannabis users. *Neuropsychobiology*, *60*(2), 94-103. <https://doi.org/10.1159/000239685>
- Martin-Soelch, C., Leenders, K. L., Chevalley, A.-F., Missimer, J., König, G., Magyar, S., ... Schultz, W. (2001). Reward mechanisms in the brain and their role in dependence: Evidence from neurophysiological and neuroimaging studies. *Brain Research Reviews*, *36*(2-3), 139-149. [https://doi.org/10.1016/S0165-0173\(01\)00089-3](https://doi.org/10.1016/S0165-0173(01)00089-3)
- Martin-Soelch, C., Linthicum, J., & Ernst, M. (2007). Appetitive conditioning: Neural bases and implications for psychopathology. *Neuroscience & Biobehavioral Reviews*, *31*(3), 426-440. <https://doi.org/10.1016/j.neubiorev.2006.11.002>
- Maxwell, M. E. (1992). *Manual for the Family Interview for Genetic Studies (FIGS)*. National Institute of Health.
- Mazure, C. M. (2000). Adverse life events and cognitive-personality characteristics in the prediction of major depression and antidepressant response. *American Journal of Psychiatry*, *157*(6), 896-903. <https://doi.org/10.1176/appi.ajp.157.6.896>
- McAdams, T. A., Neiderhiser, J. M., Rijdsdijk, F. V., Narusyte, J., Lichtenstein, P., & Eley, T. C. (2014). Accounting for genetic and environmental confounds in associations between parent and child characteristics: A systematic review of children-of-twins studies. *Psychological Bulletin*, *140*(4), 1138-1173. <https://doi.org/10.1037/a0036416>
- McAdams, T. A., Rijdsdijk, F. V., Neiderhiser, J. M., Narusyte, J., Shaw, D. S., Natsuaki, M. N., ... Eley, T. C. (2015). The relationship between parental depressive symptoms and offspring psychopathology: Evidence from a children-of-twins study and an adoption study. *Psychological Medicine*, *45*(12), 2583-2594. <https://doi.org/10.1017/S0033291715000501>

- McCabe, C., Woffindale, C., Harmer, C. J., & Cowen, P. J. (2012). Neural processing of reward and punishment in young people at increased familial risk of depression. *Biological Psychiatry*, *72*(7), 588-594. <https://doi.org/10.1016/j.biopsych.2012.04.034>
- McClure, S. M. (2004). Separate neural systems value immediate and delayed monetary rewards. *Science*, *306*(5695), 503-507. <https://doi.org/10.1126/science.1100907>
- McClure, S. M., Ericson, K. M., Laibson, D. I., Loewenstein, G., & Cohen, J. D. (2007). Time discounting for primary rewards. *Journal of Neuroscience*, *27*(21), 5796-5804. <https://doi.org/10.1523/JNEUROSCI.4246-06.2007>
- McEwen, B. S. (1998). Protective and damaging effects of stress mediators. *New England Journal of Medicine*, *338*(3), 171-179. <https://doi.org/10.1056/NEJM199801153380307>
- McEwen, B. S. (2007). Physiology and neurobiology of stress and adaptation: Central role of the brain. *Physiological Reviews*, *87*(3), 873-904. <https://doi.org/10.1152/physrev.00041.2006>
- McEwen, B. S., & Sapolsky, R. M. (1995). Stress and cognitive function. *Current Opinion in Neurobiology*, *5*(2), 205-216. [https://doi.org/10.1016/0959-4388\(95\)80028-X](https://doi.org/10.1016/0959-4388(95)80028-X)
- McEwen, B. S., Weiss, J. M., & Schwartz, L. S. (1968). Selective retention of corticosterone by limbic structures in rat brain. *Nature*, *220*(5170), 911.
- McEwen, B. S., & Wingfield, J. C. (2010). What is in a name? Integrating homeostasis, allostasis and stress. *Hormones and Behavior*, *57*(2), 105-111. <https://doi.org/10.1016/j.yhbeh.2009.09.011>
- Mendl, M. (1999). Performing under pressure: Stress and cognitive function. *Applied Animal Behaviour Science*, *65*(3), 221-244. [https://doi.org/10.1016/S0168-1591\(99\)00088-X](https://doi.org/10.1016/S0168-1591(99)00088-X)
- Menon, V. (2011). Large-scale brain networks and psychopathology: A unifying triple network model. *Trends in Cognitive Sciences*, *15*(10), 483-506. <https://doi.org/10.1016/j.tics.2011.08.003>
- Miller, E. M., Shankar, M. U., Knutson, B., & McClure, S. M. (2014). Dissociating motivation from reward in human striatal activity. *Journal of Cognitive Neuroscience*, *26*(5), 1075-1084. [https://doi.org/10.1162/jocn\\_a\\_00535](https://doi.org/10.1162/jocn_a_00535)
- Miller, R., Plessow, F., Rauh, M., Gröschl, M., & Kirschbaum, C. (2013). Comparison of salivary cortisol as measured by different immunoassays and tandem mass spectrometry. *Psychoneuroendocrinology*, *38*(1), 50-57. <https://doi.org/10.1016/j.psyneuen.2012.04.019>
- Mineka, S., & Kihlstrom, J. F. (1978). Unpredictable and uncontrollable events: A new perspective on experimental neurosis. *Journal of Abnormal Psychology*, *87*(2), 256-271. <https://doi.org/10.1037/0021-843X.87.2.256>
- Miyake, A., Friedman, N. P., Emerson, M. J., Witzki, A. H., Howerter, A., & Wager, T. D. (2000). The unity and diversity of executive functions and their contributions to complex « Frontal Lobe » tasks: A latent variable analysis. *Cognitive Psychology*, *41*(1), 49-100. <https://doi.org/10.1006/cogp.1999.0734>
- Monk, C. S., Klein, R. G., Telzer, E. H., Schroth, E. A., Mannuzza, S., Moulton, J. L., ... Ernst, M. (2008). Amygdala and nucleus accumbens activation to emotional facial expressions in children and adolescents at risk for major depression. *The American Journal of Psychiatry*, *165*(1), 90-98. <https://doi.org/10.1176/appi.ajp.2007.06111917>
- Monroe, S. M., & Simons, A. D. (1991). Diathesis-stress theories in the context of life stress research: Implications for the depressive disorders. *Psychological Bulletin*, *110*(3), 406-425.
- Montgomery, S. A., & Asberg, M. (1979). A new depression scale designed to be sensitive to change. *The British Journal of Psychiatry: The Journal of Mental Science*, *134*, 382-389.
- Montoya, E. R., Bos, P. A., Terburg, D., Rosenberger, L. A., & van Honk, J. (2014). Cortisol administration induces global down-regulation of the brain's reward circuitry. *Psychoneuroendocrinology*, *47*, 31-42. <https://doi.org/10.1016/j.psyneuen.2014.04.022>
- Morawetz, C., Bode, S., Baudewig, J., & Heekeren, H. R. (2017). Effective amygdala-prefrontal connectivity predicts individual differences in successful emotion regulation. *Social Cognitive and Affective Neuroscience*, *12*(4), 569-585. <https://doi.org/10.1093/scan/nsw169>
- Morawetz, C., Bode, S., Baudewig, J., Jacobs, A. M., & Heekeren, H. R. (2016). Neural representation of emotion regulation goals: Neural representation of emotion regulation goals. *Human Brain Mapping*, *37*(2), 600-620. <https://doi.org/10.1002/hbm.23053>

- Morawetz, C., Bode, S., Derntl, B., & Heekeren, H. R. (2017). The effect of strategies, goals and stimulus material on the neural mechanisms of emotion regulation: A meta-analysis of fMRI studies. *Neuroscience & Biobehavioral Reviews*, 72, 111-128. <https://doi.org/10.1016/j.neubiorev.2016.11.014>
- Murdaugh, D. L., Cox, J. E., Cook, E. W., & Weller, R. E. (2012). fMRI reactivity to high-calorie food pictures predicts short- and long-term outcome in a weight-loss program. *NeuroImage*, 59(3), 2709-2721. <https://doi.org/10.1016/j.neuroimage.2011.10.071>
- Naragon-Gainey, K., McMahon, T. P., & Chacko, T. P. (2017). The structure of common emotion regulation strategies: A meta-analytic examination. *Psychological Bulletin*, 143(4), 384-427. <https://doi.org/10.1037/bul0000093>
- National Institute of Mental Health. (2009). *Research Domain Criteria (RDoC)*. Consulté à l'adresse <https://www.nimh.nih.gov/research/research-funded-by-nimh/rdoc/index.shtml>
- Nelson, B. D., Kessel, E. M., Klein, D. N., & Shankman, S. A. (2018). Depression symptom dimensions and asymmetrical frontal cortical activity while anticipating reward. *Psychophysiology*, 55(1), e12892. <https://doi.org/10.1111/psyp.12892>
- Nikolova, Y. S., & Hariri, A. R. (2012). Neural responses to threat and reward interact to predict stress-related problem drinking: A novel protective role of the amygdala. *Biology of Mood & Anxiety Disorders*, 2(1). <https://doi.org/10.1186/2045-5380-2-19>
- Niv, Y., Daw, N. D., Joel, D., & Dayan, P. (2007). Tonic dopamine: Opportunity costs and the control of response vigor. *Psychopharmacology*, 191(3), 507-520. <https://doi.org/10.1007/s00213-006-0502-4>
- Novick, A. M., Levandowski, M. L., Laumann, L. E., Philip, N. S., Price, L. H., & Tyrka, A. R. (2018). The effects of early life stress on reward processing. *Journal of Psychiatric Research*, 101, 80-103. <https://doi.org/10.1016/j.jpsychires.2018.02.002>
- Nyenhuis, D. L., Yamamoto, C., Stern, R. A., Luchetta, T., & Arruda, J. E. (1997). Standardization and validation of the visual analog mood scales. *The Clinical Neuropsychologist*, 11(4), 407-415. <https://doi.org/10.1080/13854049708400470>
- Ochsner, K. N., Ray, R. D., Cooper, J. C., Robertson, E. R., Chopra, S., Gabrieli, J. D. E., & Gross, J. J. (2004). For better or for worse: Neural systems supporting the cognitive down- and up-regulation of negative emotion. *NeuroImage*, 23(2), 483-499. <https://doi.org/10.1016/j.neuroimage.2004.06.030>
- O'Connor, D. A., Rossiter, S., Yücel, M., Lubman, D. I., & Hester, R. (2012). Successful inhibitory control over an immediate reward is associated with attentional disengagement in visual processing areas. *NeuroImage*, 62(3), 1841-1847. <https://doi.org/10.1016/j.neuroimage.2012.05.040>
- O'Doherty, J. P. (2004a). Dissociable roles of ventral and dorsal striatum in instrumental conditioning. *Science*, 304(5669), 452-454. <https://doi.org/10.1126/science.1094285>
- O'Doherty, J. P. (2004b). Reward representations and reward-related learning in the human brain: Insights from neuroimaging. *Current Opinion in Neurobiology*, 14(6), 769-776. <https://doi.org/10.1016/j.conb.2004.10.016>
- O'Doherty, J. P. (2016). Multiple systems for the motivational control of behavior and associated neural substrates in humans. In E. H. Simpson & P. D. Balsam (Éd.), *Behavioral neuroscience of motivation*. Springer.
- O'Doherty, J. P., Cockburn, J., & Pauli, W. M. (2017). Learning, reward, and decision making. *Annual Review of Psychology*, 68(1), 73-100. <https://doi.org/10.1146/annurev-psych-010416-044216>
- O'Doherty, J. P., Dayan, P., Schultz, J., Deichmann, R., Friston, K., & Dolan, R. J. (2004). Dissociable roles of ventral and dorsal striatum in instrumental conditioning. *Science*, 304(5669), 452-454. <https://doi.org/10.1126/science.1094285>
- O'Doherty, J. P., Deichmann, R., Critchley, H. D., & Dolan, R. J. (2002). Neural responses during anticipation of a primary taste reward. *Neuron*, 33(5), 815-826.
- Oei, N. Y. L., Both, S., van Heemst, D., & van der Grond, J. (2014). Acute stress-induced cortisol elevations mediate reward system activity during subconscious processing of sexual stimuli. *Psychoneuroendocrinology*, 39, 111-120. <https://doi.org/10.1016/j.psyneuen.2013.10.005>
- Oei, N. Y. L., Everaerd, W. T. A. M., Elzinga, B. M., van Well, S., & Bermond, B. (2006). Psychosocial stress impairs working memory at high loads: An association with cortisol levels and memory retrieval. *Stress*, 9(3), 133-141. <https://doi.org/10.1080/10253890600965773>



- Oldfield, R. C. (1971). The assessment and analysis of handedness: The Edinburgh inventory. *Neuropsychologia*, 9(1), 97-113. [https://doi.org/10.1016/0028-3932\(71\)90067-4](https://doi.org/10.1016/0028-3932(71)90067-4)
- Oldham, S., Murawski, C., Fornito, A., Youssef, G., Yücel, M., & Lorenzetti, V. (2018). The anticipation and outcome phases of reward and loss processing: A neuroimaging meta-analysis of the monetary incentive delay task. *Human Brain Mapping*, 39(8), 3398-3418. <https://doi.org/10.1002/hbm.24184>
- Olds, J. (1956). Pleasure Centers in the Brain. *Scientific American*, 195(4), 105-117. Consulté à l'adresse JSTOR.
- Olds, J., & Milner, P. (1954). Positive reinforcement produced by electrical stimulation of septal area and other regions of rat brain. *Journal of Comparative and Physiological Psychology*, 47(6), 419-427. <https://doi.org/10.1037/h0058775>
- Olino, T. M., McMakin, D. L., Dahl, R. E., Ryan, N. D., Silk, J. S., Birmaher, B., ... Forbes, E. E. (2011). « I won, but I'm not getting my hopes up »: depression moderates the relationship of outcomes and reward anticipation. *Psychiatry Research*, 194(3), 393-395. <https://doi.org/10.1016/j.psychres.2011.04.009>
- Olino, T. M., McMakin, D. L., Morgan, J. K., Silk, J. S., Birmaher, B., Axelson, D. A., ... Forbes, E. E. (2014). Reduced reward anticipation in youth at high-risk for unipolar depression: A preliminary study. *Developmental Cognitive Neuroscience*, 8, 55-64. <https://doi.org/10.1016/j.dcn.2013.11.005>
- Olino, T. M., Silk, J. S., Osterritter, C., & Forbes, E. E. (2015). Social reward in youth at risk for depression: A preliminary investigation of subjective and neural differences. *Journal of Child and Adolescent Psychopharmacology*, 25(9), 711-721. <https://doi.org/10.1089/cap.2014.0165>
- Olney, J. J., Warlow, S. M., Naffziger, E. E., & Berridge, K. C. (2018). Current perspectives on incentive salience and applications to clinical disorders. *Current Opinion in Behavioral Sciences*, 22, 59-69. <https://doi.org/10.1016/j.cobeha.2018.01.007>
- Ossewaarde, L., Qin, S., Van Marle, H. J. F., van Wingen, G. A., Fernández, G., & Hermans, E. J. (2011). Stress-induced reduction in reward-related prefrontal cortex function. *NeuroImage*, 55(1), 345-352. <https://doi.org/10.1016/j.neuroimage.2010.11.068>
- Otto, A. R., Raio, C. M., Chiang, A., Phelps, E. A., & Daw, N. D. (2013). Working-memory capacity protects model-based learning from stress. *Proceedings of the National Academy of Sciences*, 110(52), 20941-20946. <https://doi.org/10.1073/pnas.1312011110>
- Pacák, K., & Palkovits, M. (2001). Stressor specificity of central neuroendocrine responses: Implications for stress-related disorders. *Endocrine Reviews*, 22(4), 502-548. <https://doi.org/10.1210/edrv.22.4.0436>
- Pani, L., Porcella, A., & Gessa, G. L. (2000). The role of stress in the pathophysiology of the dopaminergic system. *Molecular Psychiatry*, 5(1), 14-21. <https://doi.org/10.1038/sj.mp.4000589>
- Papadimitriou, A., & Priftis, K. N. (2009). Regulation of the hypothalamic-pituitary-adrenal axis. *Neuroimmunomodulation*, 16(5), 265-271. <https://doi.org/10.1159/000216184>
- Paulus, M. P. (2017). The effect of acute stress on the calculus of reward and punishment. *Biological Psychiatry*, 82(8), 544-546. <https://doi.org/10.1016/j.biopsych.2017.07.019>
- Pechtel, P., Dutra, S. J., Goetz, E. L., & Pizzagalli, D. A. (2013). Blunted reward responsiveness in remitted depression. *Journal of Psychiatric Research*, 47(12), 1864-1869. <https://doi.org/10.1016/j.jpsychires.2013.08.011>
- Pecina, S., & Berridge, K. C. (2005). Hedonic hot spot in nucleus accumbens shell: Where do u-opioids cause increased hedonic impact of sweetness? *Journal of Neuroscience*, 25(50), 11777-11786. <https://doi.org/10.1523/JNEUROSCI.2329-05.2005>
- Peckham, A. D., McHugh, R. K., & Otto, M. W. (2010). A meta-analysis of the magnitude of biased attention in depression. *Depression and Anxiety*, 27(12), 1135-1142. <https://doi.org/10.1002/da.20755>
- Pedroni, A., Koeneke, S., Velickaite, A., & Jäncke, L. (2011). Differential magnitude coding of gains and omitted rewards in the ventral striatum. *Brain Research*, 1411, 76-86. <https://doi.org/10.1016/j.brainres.2011.07.019>
- Pellet, J., Bobon, D. P., Mormont, I., Lang, F., & Massardier, A. (1980). *Étude Princeps de validation française de la MADRS, sous-échelle dépression de la CPRS*. Présenté à Congrès de psychiatrie et de neurologie de langue française, Reims, France.
- Pessoa, L. (2013). *The cognitive-emotional brain: From interactions to integration*. Cambridge, Massachusetts: The MIT Press.

- Peters, J., & Büchel, C. (2011). The neural mechanisms of inter-temporal decision-making: Understanding variability. *Trends in Cognitive Sciences*, 15(5), 227-239. <https://doi.org/10.1016/j.tics.2011.03.002>
- Pfaff, D. W. (1969). Parsimonious biological models of memory and reinforcement. *Psychological Review*, 76(1), 70-81. <https://doi.org/10.1037/h0026742>
- Phillips, P. E. M., Walton, M. E., & Jhou, T. C. (2007). Calculating utility: Preclinical evidence for cost–benefit analysis by mesolimbic dopamine. *Psychopharmacology*, 191(3), 483-495. <https://doi.org/10.1007/s00213-006-0626-6>
- Pierce, C. A., Block, R. A., & Aguinis, H. (2004). Cautionary note on reporting eta-squared values from multifactor ANOVA designs. *Educational and Psychological Measurement*, 64(6), 916-924. <https://doi.org/10.1177/0013164404264848>
- Pizzagalli, D. A. (2014). Depression, stress, and anhedonia: Toward a synthesis and integrated model. *Annual Review of Clinical Psychology*, 10(1), 393-423. <https://doi.org/10.1146/annurev-clinpsy-050212-185606>
- Pizzagalli, D. A., Bogdan, R., Ratner, K. G., & Jahn, A. L. (2007). Increased perceived stress is associated with blunted hedonic capacity: Potential implications for depression research. *Behaviour Research and Therapy*, 45(11), 2742-2753. <https://doi.org/10.1016/j.brat.2007.07.013>
- Pizzagalli, D. A., Holmes, A. J., Dillon, D. G., Goetz, E. L., Birk, J. L., Bogdan, R., ... Fava, M. (2009). Reduced caudate and nucleus accumbens response to rewards in unmedicated individuals with major depressive disorder. *American Journal of Psychiatry*, 166(6), 702-710. <https://doi.org/10.1176/appi.ajp.2008.08081201>
- Pizzagalli, D. A., Iosifescu, D., Hallett, L. A., Ratner, K. G., & Fava, M. (2008). Reduced hedonic capacity in major depressive disorder: Evidence from a probabilistic reward task. *Journal of Psychiatric Research*, 43(1), 76-87. <https://doi.org/10.1016/j.jpsychires.2008.03.001>
- Pochon, J. B., Levy, R., Fossati, P., Lehericy, S., Poline, J. B., Pillon, B., ... Dubois, B. (2002). The neural system that bridges reward and cognition in humans: An fMRI study. *Proceedings of the National Academy of Sciences*, 99(8), 5669-5674. <https://doi.org/10.1073/pnas.082111099>
- Pool, E., Brosch, T., Delplanque, S., & Sander, D. (2015). Stress increases cue-triggered “wanting” for sweet reward in humans. *Journal of Experimental Psychology: Animal Learning and Cognition*, 41(2), 128-136. <https://doi.org/10.1037/xan0000052>
- Pool, E., Sennwald, V., Delplanque, S., Brosch, T., & Sander, D. (2016). Measuring wanting and liking from animals to humans: A systematic review. *Neuroscience & Biobehavioral Reviews*, 63, 124-142. <https://doi.org/10.1016/j.neubiorev.2016.01.006>
- Pooresmaeili, A., Wannig, A., & Dolan, R. J. (2015). Receipt of reward leads to altered estimation of effort. *Proceedings of the National Academy of Sciences*, 112(43), 13407-13410. <https://doi.org/10.1073/pnas.1507527112>
- Porcelli, A. J., Cruz, D., Wenberg, K., Patterson, M. D., Biswal, B. B., & Rypma, B. (2008). The effects of acute stress on human prefrontal working memory systems. *Physiology & Behavior*, 95(3), 282-289. <https://doi.org/10.1016/j.physbeh.2008.04.027>
- Porcelli, A. J., Lewis, A. H., & Delgado, M. R. (2012). Acute stress influences neural circuits of reward processing. *Frontiers in Neuroscience*, 6. <https://doi.org/10.3389/fnins.2012.00157>
- Porter, R. J., Bowie, C. R., Jordan, J., & Malhi, G. S. (2013). Cognitive remediation as a treatment for major depression: A rationale, review of evidence and recommendations for future research. *Australian & New Zealand Journal of Psychiatry*, 47(12), 1165-1175. <https://doi.org/10.1177/0004867413502090>
- Pruessner, J. C., Champagne, F., Meaney, M. J., & Dagher, A. (2004). Dopamine release in response to a psychological stress in humans and its relationship to early life maternal care: A positron emission tomography study using [<sup>11</sup>C]raclopride. *The Journal of Neuroscience: The Official Journal of the Society for Neuroscience*, 24(11), 2825-2831. <https://doi.org/10.1523/JNEUROSCI.3422-03.2004>
- Qin, S., Hermans, E. J., van Marle, H. J. F., Luo, J., & Fernández, G. (2009). Acute psychological stress reduces working memory-related activity in the dorsolateral prefrontal cortex. *Biological Psychiatry*, 66(1), 25-32. <https://doi.org/10.1016/j.biopsych.2009.03.006>
- Quirarte, G. L., Ledesma de la Teja, I. S., Casillas, M., Serafin, N., Prado-Alcala, R. A., & Roozendaal, B. (2009). Corticosterone infused into the dorsal striatum selectively enhances memory consolidation of cued water-maze training. *Learning & Memory*, 16(10), 586-589. <https://doi.org/10.1101/lm.1493609>

- Quirk, G. J., & Beer, J. S. (2006). Prefrontal involvement in the regulation of emotion: Convergence of rat and human studies. *Current Opinion in Neurobiology*, *16*(6), 723-727. <https://doi.org/10.1016/j.conb.2006.07.004>
- Rademacher, L., Krach, S., Kohls, G., Irmak, A., Gründer, G., & Spreckelmeyer, K. N. (2010). Dissociation of neural networks for anticipation and consumption of monetary and social rewards. *NeuroImage*, *49*(4), 3276-3285. <https://doi.org/10.1016/j.neuroimage.2009.10.089>
- Rademacher, L., Salama, A., Gründer, G., & Spreckelmeyer, K. N. (2014). Differential patterns of nucleus accumbens activation during anticipation of monetary and social reward in young and older adults. *Social Cognitive and Affective Neuroscience*, *9*(6), 825-831. <https://doi.org/10.1093/scan/nst047>
- Raudenbush, S. W., Bryk, A. S., Cheong, Y. F., Congdon, R., & du Toit, M. (2002). *HLM 6: Hierarchical linear and nonlinear modeling [Computer software]*. Lincolnwood, Illinois, USA: Scientific Software International.
- Ray, R. D., & Zald, D. H. (2012). Anatomical insights into the interaction of emotion and cognition in the prefrontal cortex. *Neuroscience & Biobehavioral Reviews*, *36*(1), 479-501. <https://doi.org/10.1016/j.neubiorev.2011.08.005>
- Redlich, R., Dohm, K., Grotegerd, D., Opel, N., Zwieterlood, P., Heindel, W., ... Dannlowski, U. (2015). Reward processing in unipolar and bipolar depression: A functional MRI study. *Neuropsychopharmacology: Official Publication of the American College of Neuropsychopharmacology*, *40*(11), 2623-2631. <https://doi.org/10.1038/npp.2015.110>
- Reinhardt, T., Schmahl, C., Wüst, S., & Bohus, M. (2012). Salivary cortisol, heart rate, electrodermal activity and subjective stress responses to the Mannheim Multicomponent Stress Test (MMST). *Psychiatry Research*, *198*(1), 106-111. <https://doi.org/10.1016/j.psychres.2011.12.009>
- Reppermund, S., Ising, M., Lucae, S., & Zihl, J. (2009). Cognitive impairment in unipolar depression is persistent and non-specific: Further evidence for the final common pathway disorder hypothesis. *Psychological Medicine*, *39*(04), 603. <https://doi.org/10.1017/S003329170800411X>
- Richards, J. M., Plate, R. C., & Ernst, M. (2013). A systematic review of fMRI reward paradigms used in studies of adolescents vs. adults: The impact of task design and implications for understanding neurodevelopment. *Neuroscience & Biobehavioral Reviews*, *37*(5), 976-991. <https://doi.org/10.1016/j.neubiorev.2013.03.004>
- Rive, M. M., van Rooijen, G., Veltman, D. J., Phillips, M. L., Schene, A. H., & Ruhé, H. G. (2013). Neural correlates of dysfunctional emotion regulation in major depressive disorder. A systematic review of neuroimaging studies. *Neuroscience & Biobehavioral Reviews*, *37*(10), 2529-2553. <https://doi.org/10.1016/j.neubiorev.2013.07.018>
- Rizvi, S. J., Pizzagalli, D. A., Sproule, B. A., & Kennedy, S. H. (2016). Assessing anhedonia in depression: Potentials and pitfalls. *Neuroscience & Biobehavioral Reviews*, *65*, 21-35. <https://doi.org/10.1016/j.neubiorev.2016.03.004>
- Robbins, T. W., & Everitt, B. J. (1992). Functions of dopamine in the dorsal and ventral striatum. *Seminars in Neuroscience*, *4*(2), 119-127. [https://doi.org/10.1016/1044-5765\(92\)90010-Y](https://doi.org/10.1016/1044-5765(92)90010-Y)
- Robinson, M. J. F., Fischer, A. M., Ahuja, A., Lesser, E. N., & Maniates, H. (2015). Roles of “wanting” and “liking” in motivating behavior: Gambling, food, and drug addictions. In E. H. Simpson & P. D. Balsam (Éd.), *Behavioral Neuroscience of Motivation* (Vol. 27, p. 105-136). [https://doi.org/10.1007/7854\\_2015\\_387](https://doi.org/10.1007/7854_2015_387)
- Robinson, O. J., Bond, R. L., & Roiser, J. P. (2015). The impact of threat of shock on the framing effect and temporal discounting: Executive functions unperturbed by acute stress? *Frontiers in Psychology*, *6*. <https://doi.org/10.3389/fpsyg.2015.01315>
- Robinson, O. J., Letkiewicz, A. M., Overstreet, C., Ernst, M., & Grillon, C. (2011). The effect of induced anxiety on cognition: Threat of shock enhances aversive processing in healthy individuals. *Cognitive, Affective, & Behavioral Neuroscience*, *11*(2), 217-227. <https://doi.org/10.3758/s13415-011-0030-5>
- Robinson, O. J., Vytal, K., Cornwell, B. R., & Grillon, C. (2013). The impact of anxiety upon cognition: Perspectives from human threat of shock studies. *Frontiers in Human Neuroscience*, *7*. <https://doi.org/10.3389/fnhum.2013.00203>
- Robinson, T. E., & Berridge, K. C. (2000). The psychology and neurobiology of addiction: An incentive-sensitization view. *Addiction (Abingdon, England)*, *95* Suppl 2, S91-117.
- Rodrigues, S. M., LeDoux, J. E., & Sapolsky, R. M. (2009). The influence of stress hormones on fear circuitry. *Annual Review of Neuroscience*, *32*(1), 289-313. <https://doi.org/10.1146/annurev.neuro.051508.135620>
- Roesch, M. R., & Olson, C. R. (2007). Neuronal activity related to anticipated reward in frontal cortex: Does it represent value or reflect motivation? *Annals of the New York Academy of Sciences*, *1121*(1), 431-446. <https://doi.org/10.1196/annals.1401.004>

- Rogers, M. A., Kasai, K., Koji, M., Fukuda, R., Iwanami, A., Nakagome, K., ... Kato, N. (2004). Executive and prefrontal dysfunction in unipolar depression: A review of neuropsychological and imaging evidence. *Neuroscience Research*, *50*(1), 1-11. <https://doi.org/10.1016/j.neures.2004.05.003>
- Roitman, M. F., Wheeler, R. A., Tiesinga, P. H. E., Roitman, J. D., & Carelli, R. M. (2010). Hedonic and nucleus accumbens neural responses to a natural reward are regulated by aversive conditioning. *Learning & Memory*, *17*(11), 539-546. <https://doi.org/10.1101/lm.1869710>
- Rolls, E. T. (2000). The orbitofrontal cortex and reward. *Cerebral Cortex*, *10*(3), 284-294. <https://doi.org/10.1093/cercor/10.3.284>
- Römer Thomsen, K., Whybrow, P. C., & Kringelbach, M. L. (2015). Reconceptualizing anhedonia: Novel perspectives on balancing the pleasure networks in the human brain. *Frontiers in Behavioral Neuroscience*, *9*. <https://doi.org/10.3389/fnbeh.2015.00049>
- Romo, R., & Schultz, W. (1990). Dopamine neurons of the monkey midbrain: Contingencies of responses to active touch during self-initiated arm movements. *Journal of Neurophysiology*, *63*(3), 592-606. <https://doi.org/10.1152/jn.1990.63.3.592>
- Rose, E. J., & Ebmeier, K. P. (2006). Pattern of impaired working memory during major depression. *Journal of Affective Disorders*, *90*(2-3), 149-161. <https://doi.org/10.1016/j.jad.2005.11.003>
- Rothkirch, M., Schmack, K., Deserno, L., Darmohray, D., & Sterzer, P. (2014). Attentional modulation of reward processing in the human brain. *Human Brain Mapping*, *35*(7), 3036-3051. <https://doi.org/10.1002/hbm.22383>
- Russell, J. A. (2003). Core affect and the psychological construction of emotion. *Psychological Review*, *110*(1), 145-172. <https://doi.org/10.1037/0033-295X.110.1.145>
- Russo, J. E., & Doshier, B. A. (1983). Strategies for multiattribute binary choice. *Journal of Experimental Psychology. Learning, Memory, and Cognition*, *9*(4), 676-696.
- Russo, S. J., & Nestler, E. J. (2013). The brain reward circuitry in mood disorders. *Nature Reviews Neuroscience*, *14*(9), 609-625. <https://doi.org/10.1038/nrn3381>
- Salamone, J. D. (2009). Dopamine, behavioral economics, and effort. *Frontiers in Behavioral Neuroscience*, *3*. <https://doi.org/10.3389/neuro.08.013.2009>
- Salamone, J. D., & Correa, M. (2012). The mysterious motivational functions of mesolimbic dopamine. *Neuron*, *76*(3), 470-485. <https://doi.org/10.1016/j.neuron.2012.10.021>
- Salamone, J. D., Correa, M., Farrar, A., & Mingote, S. M. (2007). Effort-related functions of nucleus accumbens dopamine and associated forebrain circuits. *Psychopharmacology*, *191*(3), 461-482. <https://doi.org/10.1007/s00213-006-0668-9>
- Sánchez, M. M., Young, L. J., Plotsky, P. M., & Insel, T. R. (2000). Distribution of corticosteroid receptors in the rhesus brain: Relative absence of glucocorticoid receptors in the hippocampal formation. *The Journal of Neuroscience*, *20*(12), 4657-4668. <https://doi.org/10.1523/JNEUROSCI.20-12-04657.2000>
- Satterthwaite, T. D., Ruparel, K., Loughhead, J., Elliott, M. A., Gerraty, R. T., Calkins, M. E., ... Wolf, D. H. (2012). Being right is its own reward: Load and performance related ventral striatum activation to correct responses during a working memory task in youth. *NeuroImage*, *61*(3), 723-729. <https://doi.org/10.1016/j.neuroimage.2012.03.060>
- Savine, A. C., Beck, S. M., Edwards, B. G., Chiew, K. S., & Braver, T. S. (2010). Enhancement of cognitive control by approach and avoidance motivational states. *Cognition & Emotion*, *24*(2), 338-356. <https://doi.org/10.1080/02699930903381564>
- Saxbe, D. E. (2008). A field (researcher's) guide to cortisol: Tracking HPA axis functioning in everyday life. *Health Psychology Review*, *2*(2), 163-190. <https://doi.org/10.1080/17437190802530812>
- Saxe, R., & Haushofer, J. (2008). For love or money: A common neural currency for social and monetary reward. *Neuron*, *58*(2), 164-165. <https://doi.org/10.1016/j.neuron.2008.04.005>
- Schmitz, A., & Grillon, C. (2012). Assessing fear and anxiety in humans using the threat of predictable and unpredictable aversive events (the NPU-threat test). *Nature Protocols*, *7*(3), 527-532. <https://doi.org/10.1038/nprot.2012.001>

- Schmitz, A., Merikangas, K., Swendsen, H., Cui, L., Heaton, L., & Grillon, C. (2011). Measuring anxious responses to predictable and unpredictable threat in children and adolescents. *Journal of Experimental Child Psychology, 110*(2), 159-170. <https://doi.org/10.1016/j.jecp.2011.02.014>
- Schoenbaum, G., & Setlow, B. (2003). Lesions of nucleus accumbens disrupt learning about aversive outcomes. *The Journal of Neuroscience, 23*(30), 9833-9841. <https://doi.org/10.1523/JNEUROSCI.23-30-09833.2003>
- Schonberg, T., Daw, N. D., Joel, D., & O'Doherty, J. P. (2007). Reinforcement learning signals in the human striatum distinguish learners from nonlearners during reward-based decision making. *Journal of Neuroscience, 27*(47), 12860-12867. <https://doi.org/10.1523/JNEUROSCI.2496-07.2007>
- Schoofs, D., Preuß, D., & Wolf, O. T. (2008). Psychosocial stress induces working memory impairments in an n-back paradigm. *Psychoneuroendocrinology, 33*(5), 643-653. <https://doi.org/10.1016/j.psyneuen.2008.02.004>
- Schoupe, N., Demanet, J., Boehler, C. N., Ridderinkhof, K. R., & Notebaert, W. (2014). The role of the striatum in effort-based decision-making in the absence of reward. *Journal of Neuroscience, 34*(6), 2148-2154. <https://doi.org/10.1523/JNEUROSCI.1214-13.2014>
- Schultz, W. (1997). Dopamine neurons and their role in reward mechanisms. *Current Opinion in Neurobiology, 7*(2), 191-197. [https://doi.org/10.1016/S0959-4388\(97\)80007-4](https://doi.org/10.1016/S0959-4388(97)80007-4)
- Schultz, W. (1998). Predictive reward signal of dopamine neurons. *Journal of Neurophysiology, 80*(1), 1-27. <https://doi.org/10.1152/jn.1998.80.1.1>
- Schultz, W. (2000). Multiple reward signals in the brain. *Nature Reviews. Neuroscience, 1*(3), 199-207. <https://doi.org/10.1038/35044563>
- Schultz, W. (2002). Getting formal with dopamine and reward. *Neuron, 36*(2), 241-263. [https://doi.org/10.1016/S0896-6273\(02\)00967-4](https://doi.org/10.1016/S0896-6273(02)00967-4)
- Schultz, W. (2006). Behavioral theories and the neurophysiology of reward. *Annual Review of Psychology, 57*(1), 87-115. <https://doi.org/10.1146/annurev.psych.56.091103.070229>
- Schultz, W. (2007a). Behavioral dopamine signals. *Trends in Neurosciences, 30*(5), 203-210. <https://doi.org/10.1016/j.tins.2007.03.007>
- Schultz, W. (2007b). Multiple dopamine functions at different time courses. *Annual Review of Neuroscience, 30*(1), 259-288. <https://doi.org/10.1146/annurev.neuro.28.061604.135722>
- Schultz, W. (2013). Updating dopamine reward signals. *Current Opinion in Neurobiology, 23*(2), 229-238. <https://doi.org/10.1016/j.conb.2012.11.012>
- Schultz, W. (2016). Dopamine reward prediction-error signalling: A two-component response. *Nature Reviews Neuroscience, 17*(3), 183-195. <https://doi.org/10.1038/nrn.2015.26>
- Schultz, W. (2017). Reward prediction error. *Current Biology, 27*(10), R369-R371. <https://doi.org/10.1016/j.cub.2017.02.064>
- Schultz, W., Apicella, P., & Ljungberg, T. (1993). Responses of monkey dopamine neurons to reward and conditioned stimuli during successive steps of learning a delayed response task. *The Journal of Neuroscience, 13*(3), 900-913. <https://doi.org/10.1523/JNEUROSCI.13-03-00900.1993>
- Schultz, W., Dayan, P., & Montague, P. R. (1997). A neural substrate of prediction and reward. *Science (New York, N.Y.), 275*(5306), 1593-1599.
- Schultz, W., Stauffer, W. R., & Lak, A. (2017). The phasic dopamine signal maturing: From reward via behavioural activation to formal economic utility. *Current Opinion in Neurobiology, 43*, 139-148. <https://doi.org/10.1016/j.conb.2017.03.013>
- Schwabe, L., Oitzl, M. S., Philippson, C., Richter, S., Bohringer, A., Wippich, W., & Schachinger, H. (2007). Stress modulates the use of spatial versus stimulus-response learning strategies in humans. *Learning & Memory, 14*(1-2), 109-116. <https://doi.org/10.1101/lm.435807>
- Schwabe, L., & Wolf, O. T. (2010). Learning under stress impairs memory formation. *Neurobiology of Learning and Memory, 93*(2), 183-188. <https://doi.org/10.1016/j.nlm.2009.09.009>

- Schwabe, L., Wolf, O. T., & Oitzl, M. S. (2010). Memory formation under stress: Quantity and quality. *Neuroscience & Biobehavioral Reviews*, 34(4), 584-591. <https://doi.org/10.1016/j.neubiorev.2009.11.015>
- Selye, H. (1976). Stress without distress. In G. Serban (Éd.), *Psychopathology of Human Adaptation* (p. 137-146). [https://doi.org/10.1007/978-1-4684-2238-2\\_9](https://doi.org/10.1007/978-1-4684-2238-2_9)
- Semkowska, M., & Ahern, E. (2017). Online neurocognitive remediation therapy to improve cognition in community-living individuals with a history of depression: A pilot study. *Internet Interventions*, 9, 7-14. <https://doi.org/10.1016/j.invent.2017.04.003>
- Sennwald, V., Pool, E., & Sander, D. (2017). Considering the influence of the Pavlovian system on behavior: Appraisal and value representation. *Psychological Inquiry*, 28(1), 52-55. <https://doi.org/10.1080/1047840X.2017.1259951>
- Sescousse, G., Caldú, X., Segura, B., & Dreher, J.-C. (2013). Processing of primary and secondary rewards: A quantitative meta-analysis and review of human functional neuroimaging studies. *Neuroscience & Biobehavioral Reviews*, 37(4), 681-696. <https://doi.org/10.1016/j.neubiorev.2013.02.002>
- Sharp, C., Kim, S., Herman, L., Pane, H., Reuter, T., & Strathearn, L. (2014). Major depression in mothers predicts reduced ventral striatum activation in adolescent female offspring with and without depression. *Journal of Abnormal Psychology*, 123(2), 298-309. <https://doi.org/10.1037/a0036191>
- Sheehan, D. V., Lecrubier, Y., Sheehan, K. H., Amorim, P., Janavs, J., Weiller, E., ... Dunbar, G. C. (1998). The Mini-International Neuropsychiatric Interview (M.I.N.I.): The development and validation of a structured diagnostic psychiatric interview for DSM-IV and ICD-10. *The Journal of Clinical Psychiatry*, 59 Suppl 20, 22-33;quiz 34-57.
- Shenhav, A., Musslick, S., Lieder, F., Kool, W., Griffiths, T. L., Cohen, J. D., & Botvinick, M. M. (2017). Toward a rational and mechanistic account of mental effort. *Annual Review of Neuroscience*, 40(1), 99-124. <https://doi.org/10.1146/annurev-neuro-072116-031526>
- Sherdell, L., Waugh, C. E., & Gotlib, I. H. (2012). Anticipatory pleasure predicts motivation for reward in major depression. *Journal of Abnormal Psychology*, 121(1), 51-60. <https://doi.org/10.1037/a0024945>
- Shields, G. S., Bonner, J. C., & Moons, W. G. (2015). Does cortisol influence core executive functions? A meta-analysis of acute cortisol administration effects on working memory, inhibition, and set-shifting. *Psychoneuroendocrinology*, 58, 91-103. <https://doi.org/10.1016/j.psyneuen.2015.04.017>
- Shin, L. M., & Liberzon, I. (2010). The neurocircuitry of fear, stress and anxiety disorders. *Neuropsychopharmacology*, 35(1), 169-191. <https://doi.org/10.1038/npp.2009.83>
- Silvestrini, N. (2017). Psychological and neural mechanisms associated with effort-related cardiovascular reactivity and cognitive control: An integrative approach. *International Journal of Psychophysiology: Official Journal of the International Organization of Psychophysiology*, 119, 11-18. <https://doi.org/10.1016/j.ijpsycho.2016.12.009>
- Simon, J. J., Skunde, M., Wu, M., Schnell, K., Herpertz, S. C., Bendszus, M., ... Friederich, H.-C. (2015). Neural dissociation of food- and money-related reward processing using an abstract incentive delay task. *Social Cognitive and Affective Neuroscience*, 10(8), 1113-1120. <https://doi.org/10.1093/scan/nsu162>
- Simpson, E. H., & Balsam, P. D. (2016). The behavioral neuroscience of motivation: An overview of concepts, measures, and translational applications. In E. H. Simpson & P. D. Balsam (Éd.), *Behavioral neuroscience of motivation* (p. 1-14). Cham, Zug, Switzerland: Springer International Publishing.
- Singh, A. L., D'Onofrio, B. M., Slutske, W. S., Turkheimer, E., Emery, R. E., Harden, K. P., ... Martin, N. G. (2011). Parental depression and offspring psychopathology: A children of twins study. *Psychological Medicine*, 41(07), 1385-1395. <https://doi.org/10.1017/S0033291710002059>
- Skinner, B. F. (1938). *The behavior of organisms: An experimental analysis* (Appleton-Century-Crofts). New-York, NY, USA: Elliott, Richard M.
- Smeets, T., Cornelisse, S., Quaedflieg, C. W. E. M., Meyer, T., Jelicic, M., & Merckelbach, H. (2012). Introducing the Maastricht Acute Stress Test (MAST): A quick and non-invasive approach to elicit robust autonomic and glucocorticoid stress responses. *Psychoneuroendocrinology*, 37(12), 1998-2008. <https://doi.org/10.1016/j.psyneuen.2012.04.012>
- Smith, K. S., & Berridge, K. C. (2005). The ventral pallidum and hedonic reward: Neurochemical maps of sucrose « liking » and food intake. *Journal of Neuroscience*, 25(38), 8637-8649. <https://doi.org/10.1523/JNEUROSCI.1902-05.2005>

- Smith, K. S., Tindell, A. J., Aldridge, J. W., & Berridge, K. C. (2009). Ventral pallidum roles in reward and motivation. *Behavioural Brain Research*, *196*(2), 155-167. <https://doi.org/10.1016/j.bbr.2008.09.038>
- Smoski, M. J., Felder, J., Bizzell, J., Green, S. R., Ernst, M., Lynch, T. R., & Dichter, G. S. (2009). fMRI of alterations in reward selection, anticipation, and feedback in major depressive disorder. *Journal of Affective Disorders*, *118*(1-3), 69-78. <https://doi.org/10.1016/j.jad.2009.01.034>
- Smoski, M. J., Rittenberg, A., & Dichter, G. S. (2011). Major depressive disorder is characterized by greater reward network activation to monetary than pleasant image rewards. *Psychiatry Research: Neuroimaging*, *194*(3), 263-270. <https://doi.org/10.1016/j.psychres.2011.06.012>
- Snaith, R. P., Hamilton, M., Morley, S., Humayan, A., Hargreaves, D., & Trigwell, P. (1995). A scale for the assessment of hedonic tone the Snaith-Hamilton Pleasure Scale. *British Journal of Psychiatry*, *167*(01), 99-103. <https://doi.org/10.1192/bjp.167.1.99>
- Snyder, H. R. (2013). Major depressive disorder is associated with broad impairments on neuropsychological measures of executive function: A meta-analysis and review. *Psychological Bulletin*, *139*(1), 81-132. <https://doi.org/10.1037/a0028727>
- Soares, J. M., Sampaio, A., Marques, P., Ferreira, L. M., Santos, N. C., Marques, F., ... Sousa, N. (2013). Plasticity of resting state brain networks in recovery from stress. *Frontiers in Human Neuroscience*, *7*, 919. <https://doi.org/10.3389/fnhum.2013.00919>
- Soares-Cunha, C., Coimbra, B., Sousa, N., & Rodrigues, A. J. (2016). Reappraising striatal D1- and D2-neurons in reward and aversion. *Neuroscience and Biobehavioral Reviews*, *68*, 370-386. <https://doi.org/10.1016/j.neubiorev.2016.05.021>
- Steele, J. D., Kumar, P., & Ebmeier, K. P. (2007). Blunted response to feedback information in depressive illness. *Brain: A Journal of Neurology*, *130*(Pt 9), 2367-2374. <https://doi.org/10.1093/brain/awm150>
- Stefanek, E., Strohmeier, D., Fandrem, H., & Spiel, C. (2012). Depressive symptoms in native and immigrant adolescents: The role of critical life events and daily hassles. *Anxiety, Stress & Coping*, *25*(2), 201-217. <https://doi.org/10.1080/10615806.2011.605879>
- Steiner, J. E., Glaser, D., Hawilo, M. E., & Berridge, K. C. (2001). Comparative expression of hedonic impact: Affective reactions to taste by human infants and other primates. *Neuroscience & Biobehavioral Reviews*, *25*(1), 53-74. [https://doi.org/10.1016/S0149-7634\(00\)00051-8](https://doi.org/10.1016/S0149-7634(00)00051-8)
- Stoppel, C. M., Boehler, C. N., Strumpf, H., Heinze, H.-J., Hopf, J.-M., & Schoenfeld, M. A. (2011). Neural processing of reward magnitude under varying attentional demands. *Brain Research*, *1383*, 218-229. <https://doi.org/10.1016/j.brainres.2011.01.095>
- Stoy, M., Schlagenhaut, F., Sterzer, P., Bermpohl, F., Hägele, C., Suchotzki, K., ... Ströhle, A. (2012). Hyporeactivity of ventral striatum towards incentive stimuli in unmedicated depressed patients normalizes after treatment with escitalopram. *Journal of Psychopharmacology*, *26*(5), 677-688. <https://doi.org/10.1177/0269881111416686>
- Strauss, G. P., Waltz, J. A., & Gold, J. M. (2014). A review of reward processing and motivational impairment in schizophrenia. *Schizophrenia Bulletin*, *40*(Suppl 2), S107-S116. <https://doi.org/10.1093/schbul/sbt197>
- Strauss, M., Mergl, R., Gürke, N., Kleinert, K., Sander, C., & Hegerl, U. (2018). Association between acute critical life events and the speed of onset of depressive episodes in male and female depressed patients. *BMC Psychiatry*, *18*(1). <https://doi.org/10.1186/s12888-018-1923-4>
- Stringaris, A., Vidal-Ribas Belil, P., Artiges, E., Lemaitre, H., Gollier-Briant, F., Wolke, S., ... IMAGEN Consortium. (2015). The brain's response to reward anticipation and depression in adolescence: Dimensionality, specificity, and longitudinal predictions in a community-based sample. *American Journal of Psychiatry*, *172*(12), 1215-1223. <https://doi.org/10.1176/appi.ajp.2015.14101298>
- Sullivan, P. F., Neale, M. C., & Kendler, K. S. (2000). Genetic epidemiology of major depression: Review and meta-Analysis. *American Journal of Psychiatry*, *157*(10), 1552-1562. <https://doi.org/10.1176/appi.ajp.157.10.1552>
- Swaab, D. F., Bao, A.-M., & Lucassen, P. J. (2005). The stress system in the human brain in depression and neurodegeneration. *Ageing Research Reviews*, *4*(2), 141-194. <https://doi.org/10.1016/j.arr.2005.03.003>
- Sylvers, P., Lilienfeld, S. O., & LaPrairie, J. L. (2011). Differences between trait fear and trait anxiety: Implications for psychopathology. *Clinical Psychology Review*, *31*(1), 122-137. <https://doi.org/10.1016/j.cpr.2010.08.004>

- Szabo, S., Tache, Y., & Somogyi, A. (2012). The legacy of Hans Selye and the origins of stress research: A retrospective 75 years after his landmark brief "Letter" to the Editor of Nature. *Stress*, *15*(5), 472-478. <https://doi.org/10.3109/10253890.2012.710919>
- Taha, S. A. (2005). Encoding of palatability and appetitive behaviors by distinct neuronal populations in the nucleus accumbens. *Journal of Neuroscience*, *25*(5), 1193-1202. <https://doi.org/10.1523/JNEUROSCI.3975-04.2005>
- Tanaka, Y., Ishitobi, Y., Maruyama, Y., Kawano, A., Ando, T., Okamoto, S., ... Akiyoshi, J. (2012). Salivary alpha-amylase and cortisol responsiveness following electrical stimulation stress in major depressive disorder patients. *Progress in Neuro-Psychopharmacology & Biological Psychiatry*, *36*(2), 220-224. <https://doi.org/10.1016/j.pnpbp.2011.10.005>
- Tang, D. W., Fellows, L. K., Small, D. M., & Dagher, A. (2012). Food and drug cues activate similar brain regions: A meta-analysis of functional MRI studies. *Physiology & Behavior*, *106*(3), 317-324. <https://doi.org/10.1016/j.physbeh.2012.03.009>
- Thorndike, E. L. (1911). *Animal intelligence*. Norwood, Massachusetts, USA: Norwood Press.
- Thorndike, E. L. (1927). The law of effect. *The American Journal of Psychology*, *39*(1/4), 212. <https://doi.org/10.2307/1415413>
- Tibboel, H., De Houwer, J., & Van Bockstaele, B. (2015). Implicit measures of "wanting" and "liking" in humans. *Neuroscience & Biobehavioral Reviews*, *57*, 350-364. <https://doi.org/10.1016/j.neubiorev.2015.09.015>
- Tindell, A. J. (2004). Ventral pallidal representation of Pavlovian cues and reward: Population and rate codes. *Journal of Neuroscience*, *24*(5), 1058-1069. <https://doi.org/10.1523/JNEUROSCI.1437-03.2004>
- Tindell, A. J., Smith, K. S., Peciña, S., Berridge, K. C., & Aldridge, J. W. (2006). Ventral pallidum firing codes hedonic reward: When a bad taste turns good. *Journal of Neurophysiology*, *96*(5), 2399-2409. <https://doi.org/10.1152/jn.00576.2006>
- Tomonaga, Y., Haettenschwiler, J., Hatzinger, M., Holsboer-Trachsler, E., Rufer, M., Hepp, U., & Szucs, T. D. (2013). The economic burden of depression in Switzerland. *PharmacoEconomics*, *31*(3), 237-250. <https://doi.org/10.1007/s40273-013-0026-9>
- Torrissi, S., Gorka, A. X., Gonzalez-Castillo, J., O'Connell, K., Balderston, N., Grillon, C., & Ernst, M. (2018). Extended amygdala connectivity changes during sustained shock anticipation. *Translational Psychiatry*, *8*(1). <https://doi.org/10.1038/s41398-017-0074-6>
- Torrissi, S., O'Connell, K., Davis, A., Reynolds, R., Balderston, N., Fudge, J. L., ... Ernst, M. (2015). Resting state connectivity of the bed nucleus of the stria terminalis at ultra-high field: Resting state connectivity of BNST. *Human Brain Mapping*, *36*(10), 4076-4088. <https://doi.org/10.1002/hbm.22899>
- Torrissi, S., Robinson, O. J., O'Connell, K., Davis, A., Balderston, N., Ernst, M., & Grillon, C. (2016). The neural basis of improved cognitive performance by threat of shock. *Social Cognitive and Affective Neuroscience*, *11*(11), 1677-1686. <https://doi.org/10.1093/scan/nsw088>
- Treadway, M. T., Bossaller, N. A., Shelton, R. C., & Zald, D. H. (2012). Effort-based decision-making in major depressive disorder: A translational model of motivational anhedonia. *Journal of Abnormal Psychology*, *121*(3), 553-558. <https://doi.org/10.1037/a0028813>
- Treadway, M. T., Buckholtz, J. W., Cowan, R. L., Woodward, N. D., Li, R., Ansari, M. S., ... Zald, D. H. (2012). Dopaminergic mechanisms of individual differences in human effort-based decision-making. *Journal of Neuroscience*, *32*(18), 6170-6176. <https://doi.org/10.1523/JNEUROSCI.6459-11.2012>
- Treadway, M. T., Buckholtz, J. W., & Zald, D. H. (2013). Perceived stress predicts altered reward and loss feedback processing in medial prefrontal cortex. *Frontiers in Human Neuroscience*, *7*. <https://doi.org/10.3389/fnhum.2013.00180>
- Treadway, M. T., & Zald, D. H. (2011). Reconsidering anhedonia in depression: Lessons from translational neuroscience. *Neuroscience and Biobehavioral Reviews*, *35*(3), 537-555. <https://doi.org/10.1016/j.neubiorev.2010.06.006>
- Tricomi, E., & Fiez, J. A. (2012). Information content and reward processing in the human striatum during performance of a declarative memory task. *Cognitive, Affective, & Behavioral Neuroscience*, *12*(2), 361-372. <https://doi.org/10.3758/s13415-011-0077-3>



- Tversky, A., & Kahneman, D. (1992). Advances in prospect theory: Cumulative representation of uncertainty. *Journal of Risk and Uncertainty*, 5(4), 297-323. <https://doi.org/10.1007/BF00122574>
- Ubl, B., Kuehner, C., Kirsch, P., Ruttorf, M., Diener, C., & Flor, H. (2015). Altered neural reward and loss processing and prediction error signalling in depression. *Social Cognitive and Affective Neuroscience*, 10(8), 1102-1112. <https://doi.org/10.1093/scan/nsu158>
- Ubl, B., Kuehner, C., Kirsch, P., Ruttorf, M., Flor, H., & Diener, C. (2015). Neural reward processing in individuals remitted from major depression. *Psychological Medicine*, 45(16), 3549-3558. <https://doi.org/10.1017/S0033291715001452>
- Ulrich-Lai, Y. M., & Herman, J. P. (2009). Neural regulation of endocrine and autonomic stress responses. *Nature Reviews Neuroscience*, 10(6), 397-409. <https://doi.org/10.1038/nrn2647>
- Ungerstedt, U. (1971). Adipsia and aphagia after 6-hydroxydopamine induced degeneration of the nigro-striatal dopamine system. *Acta Physiologica Scandinavica*, 82(S367), 95-122. <https://doi.org/10.1111/j.1365-201X.1971.tb11001.x>
- Ungless, M. A., Argilli, E., & Bonci, A. (2010). Effects of stress and aversion on dopamine neurons: Implications for addiction. *Neuroscience & Biobehavioral Reviews*, 35(2), 151-156. <https://doi.org/10.1016/j.neubiorev.2010.04.006>
- Vaessen, T., Hernaes, D., Myin-Germeys, I., & van Amelsvoort, T. (2015). The dopaminergic response to acute stress in health and psychopathology: A systematic review. *Neuroscience & Biobehavioral Reviews*, 56, 241-251. <https://doi.org/10.1016/j.neubiorev.2015.07.008>
- Valenstein, E. S., Cox, V. C., & Kakolewski, J. W. (1970). Reexamination of the role of the hypothalamus in motivation. *Psychological Review*, 77(1), 16-31. <https://doi.org/10.1037/h0028581>
- Van Leijenhorst, L., Zanolie, K., Van Meel, C. S., Westenberg, P. M., Rombouts, S. A. R. B., & Crone, E. A. (2010). What motivates the adolescent? Brain regions mediating reward sensitivity across adolescence. *Cerebral Cortex*, 20(1), 61-69. <https://doi.org/10.1093/cercor/bhp078>
- van Oort, J., Tendolkar, I., Hermans, E. J., Mulders, P. C., Beckmann, C. F., Schene, A. H., ... van Eijndhoven, P. F. (2017). How the brain connects in response to acute stress: A review at the human brain systems level. *Neuroscience & Biobehavioral Reviews*, 83, 281-297. <https://doi.org/10.1016/j.neubiorev.2017.10.015>
- van Stegeren, A. H., Wolf, O. T., & Kindt, M. (2008). Salivary alpha amylase and cortisol responses to different stress tasks: Impact of sex. *International Journal of Psychophysiology*, 69(1), 33-40. <https://doi.org/10.1016/j.ijpsycho.2008.02.008>
- Vassena, E., Silvetti, M., Boehler, C. N., Achten, E., Fias, W., & Verguts, T. (2014). Overlapping neural systems represent cognitive effort and reward anticipation. *PLoS ONE*, 9(3), e91008. <https://doi.org/10.1371/journal.pone.0091008>
- Veale, J. F. (2014). Edinburgh Handedness Inventory – Short Form: A revised version based on confirmatory factor analysis. *Laterality: Asymmetries of Body, Brain and Cognition*, 19(2), 164-177. <https://doi.org/10.1080/1357650X.2013.783045>
- Veen, G., van Vliet, I. M., DeRijk, R. H., Giltay, E. J., van Pelt, J., & Zitman, F. G. (2011). Basal cortisol levels in relation to dimensions and DSM-IV categories of depression and anxiety. *Psychiatry Research*, 185(1-2), 121-128. <https://doi.org/10.1016/j.psychres.2009.07.013>
- Venugopalan, V., Casey, K. F., O'Hara, C., O'Loughlin, J., Benkelfat, C., Fellows, L. K., & Leyton, M. (2011). Acute phenylalanine/tyrosine depletion reduces motivation to smoke cigarettes across stages of addiction. *Neuropsychopharmacology*, 36(12), 2469-2476. <https://doi.org/10.1038/npp.2011.135>
- Volkow, N. D., & Morales, M. (2015). The brain on drugs: From reward to addiction. *Cell*, 162(4), 712-725. <https://doi.org/10.1016/j.cell.2015.07.046>
- Vreeburg, S. A., Hoogendijk, W. J. G., van Pelt, J., DeRijk, R. H., Verhagen, J. C. M., van Dyck, R., ... Penninx, B. W. J. H. (2009). Major depressive disorder and hypothalamic-pituitary-adrenal axis activity: Results from a large cohort study. *Archives of General Psychiatry*, 66(6), 617. <https://doi.org/10.1001/archgenpsychiatry.2009.50>
- Vrieze, E., Pizzagalli, D. A., Demyttenaere, K., Hompes, T., Sienaert, P., de Boer, P., ... Claes, S. (2013). Reduced reward learning predicts outcome in major depressive disorder. *Biological Psychiatry*, 73(7), 639-645. <https://doi.org/10.1016/j.biopsych.2012.10.014>

- Wager, T. D., Davidson, M. L., Hughes, B. L., Lindquist, M. A., & Ochsner, K. N. (2008). Prefrontal-subcortical pathways mediating successful emotion regulation. *Neuron*, *59*(6), 1037-1050. <https://doi.org/10.1016/j.neuron.2008.09.006>
- Walker, D. L., & Davis, M. (2008). Role of the extended amygdala in short-duration versus sustained fear: A tribute to Dr. Lennart Heimer. *Brain Structure and Function*, *213*(1-2), 29-42. <https://doi.org/10.1007/s00429-008-0183-3>
- Walker, D. L., Miles, L. A., & Davis, M. (2009). Selective participation of the bed nucleus of the stria terminalis and CRF in sustained anxiety-like versus phasic fear-like responses. *Progress in Neuro-Psychopharmacology and Biological Psychiatry*, *33*(8), 1291-1308. <https://doi.org/10.1016/j.pnpbp.2009.06.022>
- Walton, M. E., Kennerley, S. W., Bannerman, D. M., Phillips, P. E. M., & Rushworth, M. F. S. (2006). Weighing up the benefits of work: Behavioral and neural analyses of effort-related decision making. *Neural Networks*, *19*(8), 1302-1314. <https://doi.org/10.1016/j.neunet.2006.03.005>
- Wang, Y.-P., & Gorenstein, C. (2013). Psychometric properties of the Beck Depression Inventory-II: A comprehensive review. *Revista Brasileira de Psiquiatria*, *35*(4), 416-431. <https://doi.org/10.1590/1516-4446-2012-1048>
- Wardenaar, K. J., Vreeburg, S. A., van Veen, T., Giltay, E. J., Veen, G., Penninx, B. W. J. H., & Zitman, F. G. (2011). Dimensions of depression and anxiety and the hypothalamo-pituitary-adrenal axis. *Biological Psychiatry*, *69*(4), 366-373. <https://doi.org/10.1016/j.biopsych.2010.09.005>
- Webber, E. S., Mankin, D. E., & Cromwell, H. C. (2016). Striatal activity and reward relativity: Neural signals encoding dynamic outcome valuation. *ENeuro*, *3*(5). <https://doi.org/10.1523/ENEURO.0022-16.2016>
- Weerda, R., Muehlhan, M., Wolf, O. T., & Thiel, C. M. (2010). Effects of acute psychosocial stress on working memory related brain activity in men. *Human Brain Mapping*, *31*(9), 1418-1429. <https://doi.org/10.1002/hbm.20945>
- Weiner, B. (1992). *Human motivation: Metaphors, theories, and research*. Newbury Park, CA: Sage Publishers.
- Weissman, M. M., Wickramaratne, P., Gameroff, M. J., Warner, V., Pilowsky, D., Kohad, R. G., ... Talati, A. (2016). Offspring of depressed parents: 30 years later. *American Journal of Psychiatry*, *173*(10), 1024-1032. <https://doi.org/10.1176/appi.ajp.2016.15101327>
- Westbrook, A., & Braver, T. S. (2015). Cognitive effort: A neuroeconomic approach. *Cognitive, Affective, & Behavioral Neuroscience*, *15*(2), 395-415. <https://doi.org/10.3758/s13415-015-0334-y>
- Whisman, M. A., Perez, J. E., & Ramel, W. (2000). Factor structure of the Beck Depression Inventory-Second Edition (BDI-II) in a student sample. *Journal of Clinical Psychology*, *56*(4), 545-551.
- White, N. M. (2011). Reward: What is it? How can it be inferred from behavior? In J. A. Gottfried (Éd.), *Neurobiology of Sensation and Reward* (p. 45-60). Boca Raton, FL, USA: CRC Press/Taylor & Francis.
- Williams, S. M. (1991). Handedness inventories: Edinburgh versus Annett. *Neuropsychology*, *5*(1), 43-48. <https://doi.org/10.1037/0894-4105.5.1.43>
- Williamson, D. E., Birmaher, B., Axelson, D. A., Ryan, N. D., & Dahl, R. E. (2004). First episode of depression in children at low and high familial risk for depression. *Journal of the American Academy of Child & Adolescent Psychiatry*, *43*(3), 291-297. <https://doi.org/10.1097/00004583-200403000-00010>
- Willner, P. (2005). Chronic Mild Stress (CMS) revisited: Consistency and behavioural-neurobiological concordance in the effects of CMS. *Neuropsychobiology*, *52*(2), 90-110. <https://doi.org/10.1159/000087097>
- Willner, P., Moreau, J. L., Nielsen, C. K., Papp, M., & Sluzewska, A. (1996). Decreased hedonic responsiveness following chronic mild stress is not secondary to loss of body weight. *Physiology & Behavior*, *60*(1), 129-134.
- Wilson, R. P., Colizzi, M., Bossong, M. G., Allen, P., Kempton, M., & Bhattacharyya, S. (2018). The neural substrate of reward anticipation in health: A meta-analysis of fMRI findings in the Monetary Incentive Delay task. *Neuropsychology Review*, *28*(4), 496-506. <https://doi.org/10.1007/s11065-018-9385-5>
- Wise, R. A. (1982). Neuroleptics and operant behavior: The anhedonia hypothesis. *Behavioral and Brain Sciences*, *5*(01), 39. <https://doi.org/10.1017/S0140525X00010372>
- Wise, R. A. (2004). Dopamine, learning and motivation. *Nature Reviews Neuroscience*, *5*(6), 483-494. <https://doi.org/10.1038/nrn1406>

- Wittchen, H. U., Jacobi, F., Rehm, J., Gustavsson, A., Svensson, M., Jönsson, B., ... Steinhausen, H.-C. (2011). The size and burden of mental disorders and other disorders of the brain in Europe 2010. *European Neuropsychopharmacology*, 21(9), 655-679. <https://doi.org/10.1016/j.euroneuro.2011.07.018>
- Wittmann, M. K., Kolling, N., Akaishi, R., Chau, B. K. H., Brown, J. W., Nelissen, N., & Rushworth, M. F. S. (2016). Predictive decision making driven by multiple time-linked reward representations in the anterior cingulate cortex. *Nature Communications*, 7, 12327. <https://doi.org/10.1038/ncomms12327>
- World Health Organization. (2017). *Depression and other common mental disorders: Global health estimates* (N° WHO/MSD/MER/2017.2; p. 24). Consulté à l'adresse <https://apps.who.int/iris/bitstream/handle/10665/254610/WHO-MSD-MER-2017.2-eng.pdf;jsessionid=781468FDE2879C09EA4AD00F8B394C46?sequence=1>
- Yang, X., Huang, J., Lan, Y., Zhu, C., Liu, X., Wang, Y., ... Chan, R. C. K. (2016). Diminished caudate and superior temporal gyrus responses to effort-based decision making in patients with first-episode major depressive disorder. *Progress in Neuro-Psychopharmacology and Biological Psychiatry*, 64, 52-59. <https://doi.org/10.1016/j.pnpbp.2015.07.006>
- Yang, X., Huang, J., Zhu, C., Wang, Y., Cheung, E. F. C., Chan, R. C. K., & Xie, G. (2014). Motivational deficits in effort-based decision making in individuals with subsyndromal depression, first-episode and remitted depression patients. *Psychiatry Research*, 220(3), 874-882. <https://doi.org/10.1016/j.psychres.2014.08.056>
- Yee, D. M., & Braver, T. S. (2018). Interactions of motivation and cognitive control. *Current Opinion in Behavioral Sciences*, 19, 83-90. <https://doi.org/10.1016/j.cobeha.2017.11.009>
- Yuen, E. Y., Liu, W., Karatsoreos, I. N., Feng, J., McEwen, B. S., & Yan, Z. (2009). Acute stress enhances glutamatergic transmission in prefrontal cortex and facilitates working memory. *Proceedings of the National Academy of Sciences*, 106(33), 14075-14079. <https://doi.org/10.1073/pnas.0906791106>
- Yuen, E. Y., Liu, W., Karatsoreos, I. N., Ren, Y., Feng, J., McEwen, B. S., & Yan, Z. (2011). Mechanisms for acute stress-induced enhancement of glutamatergic transmission and working memory. *Molecular Psychiatry*, 16(2), 156-170. <https://doi.org/10.1038/mp.2010.50>
- Zald, D. H., & Treadway, M. T. (2017). Reward processing, neuroeconomics, and psychopathology. *Annual Review of Clinical Psychology*, 13(1), 471-495. <https://doi.org/10.1146/annurev-clinpsy-032816-044957>
- Zandara, M., Garcia-Lluch, M., Pulpulos, M. M., Hidalgo, V., Villada, C., & Salvador, A. (2016). Acute stress and working memory: The role of sex and cognitive stress appraisal. *Physiology & Behavior*, 164, 336-344. <https://doi.org/10.1016/j.physbeh.2016.06.022>
- Zhang, W.-N., Chang, S.-H., Guo, L.-Y., Zhang, K.-L., & Wang, J. (2013). The neural correlates of reward-related processing in major depressive disorder: A meta-analysis of functional magnetic resonance imaging studies. *Journal of Affective Disorders*, 151(2), 531-539. <https://doi.org/10.1016/j.jad.2013.06.039>
- Zorn, J. V., Schür, R. R., Boks, M. P., Kahn, R. S., Joëls, M., & Vinkers, C. H. (2017). Cortisol stress reactivity across psychiatric disorders: A systematic review and meta-analysis. *Psychoneuroendocrinology*, 77, 25-36. <https://doi.org/10.1016/j.psyneuen.2016.11.036>



## APPENDIX

### A. Empirical work I – Supplemental results

#### A.1 Significant whole-brain activations during the anticipation phase

Table A.1

*Significant whole-brain clusters (cluster-size corrected) for the main effects of stress, reward, and working memory (WM) load, as well as their interactions during the anticipation phase*

Activated clusters in brain regions	Side	MNI coordinates (LPI)			Cluster size	T-Value
		x	y	z		
Main effect of reward : rewarded > not-rewarded trials						
Lateral occipital	L	-47	-86	-11	456	4.32
Fusiform	R	50	-65	-20	297	5.56
Superior parietal	L	-8	-80	53	70	4.03
Lateral occipital	R	38	-92	14	61	4.11
Superior parietal	R	29	-59	68	34	4.13
Supramarginal	L	-53	-38	56	31	4.45
Superior parietal	R	32	-41	50	30	4.63
Rostral middle frontal	L	-41	50	2	27	4.60
Superior parietal	L	-20	-83	41	27	4.75
Lingual	R	8	-83	-17	25	3.84
Cerebral white matter	L	-20	-71	8	24	4.89
Superior parietal	R	23	-83	50	21	5.68
Main effect of WM load : high > low loads						
Lingual	L	-1	-85	0	1675	7.83
Interaction effect : Reward × Stress						
Rewarded > not-rewarded trials in the control condition						
Inferior temporal	L	-50	-62	-20	203	3.81
Lateral occipital	R	44	-77	-17	126	5.01
Superior parietal	L	-8	-77	53	120	4.32
Lateral occipital	L	-29	-98	14	62	5.42
Superior parietal	R	23	-80	50	33	3.93
Lateral occipital	R	32	-95	20	21	4.27
Rostral middle frontal	L	-35	53	-2	20	4.42
Superior parietal	L	-35	-62	53	18	5.11
Rewarded > not-rewarded trials in the stress condition						
Lateral occipital	L	-47	-86	-11	210	4.96
Cerebellum	R	50	-71	-26	25	4.03
Lateral occipital	R	53	-74	-8	22	4.35
Parietal occipital	L	-17	-71	11	18	4.05
Postcentral	R	35	-35	47	18	4.29

Activated clusters in brain regions	Side	MNI coordinates (LPI)			Cluster size	T-Value
		x	y	z		
Interaction effect : Reward $\times$ WM load						
Rewarded > not-rewarded trials in the low load condition						
Lateral occipital	L	-44	-86	-11	227	6.14
Fusiform	R	50	-65	-20	152	4.12
Lateral occipital	R	38	-92	14	64	4.33
Inferior parietal	L	-32	-77	29	29	4.50
Superior parietal	L	-44	-47	56	21	3.80
Sulcus parieto-occipital	L	-20	-71	11	18	4.38
Superior parietal	L	-23	-65	53	18	4.96
Rewarded > not-rewarded trials in the high load condition						
Fusiform	L	-47	-62	-20	211	4.40
Lateral occipital	R	50	-77	-14	61	5.62
Superior parietal	L	-29	-68	53	30	4.41
Lingual	R	2	-80	-5	27	4.50
Lateral occipital	L	-29	-98	14	18	4.20
Interaction effect : Stress $\times$ WM load						
High > low loads in the control condition						
Lingual	R	20	-77	-14	1214	6.20
High > low loads in the stress condition						
Cerebellum	R	20	-80	-14	856	7.05
Interaction effect : Reward $\times$ Stress $\times$ WM load						
Rewarded > not-rewarded trials in the low load and control conditions						
Lateral occipital	L	-41	-83	-14	34	4.16
Inferior parietal	L	-38	-92	14	30	3.99
Fusiform	R	47	-65	-20	20	4.20
Rewarded > not-rewarded trials in the high load and control conditions						
Fusiform	L	-43	-67	-15	99	4.61
Lateral occipital	R	46	-74	-14	24	4.16
Superior parietal	L	-13	-73	48	24	5.12
Lateral occipital	L	-31	-93	15	21	5.02
Rewarded > not-rewarded trials in the low load and stress conditions						
Lateral occipital	L	-47	-86	-11	63	3.84
Lateral occipital	L	-26	-98	14	45	4.23
Lateral occipital	R	38	-77	-11	25	4.52
Supramarginal	L	-50	-32	50	21	4.41
Rewarded > not-rewarded trials in the high load and stress conditions						
Lateral occipital	L	-50	-83	-5	36	5.15
Fusiform	L	-35	-59	-17	25	4.66
Fusiform	L	-35	-74	-17	17	4.29
Cerebellum	L	-11	-68	-17	17	7.71

*Note.* Whole-brain activations presented for every specific contrasts are corrected for multiple comparisons using a cluster-based approach with a voxelwise  $p$ -value threshold of  $p < 0.001$  and a minimum cluster size of  $k = 18$ , which corresponds to a cluster-level alpha of  $p < 0.05$ . L, left ; R, right; LPI means that x increases from Left to Right, y increases from Posterior to Anterior, z increases from Inferior to Superior.

## A.2 Significant whole-brain activations during the delivery phase

Table A.2

*Significant whole-brain clusters (cluster-size corrected) for the main effects of stress, reward, and working memory (WM) load, as well as their interactions during the delivery phase*

Activated clusters in brain regions	Side	MNI coordinates (LPI)			Cluster size	T-Value
		x	y	z		
Main effect of reward : rewarded > not-rewarded trials						
Lateral occipital	L	-47	-86	-11	2859	5.38
Rostral ACC	R	2	47	8	626	6.57
Superior parietal	R	35	-68	59	157	4.30
Lateral orbitofrontal	R	47	26	-17	78	5.58
Middle temporal	L	-65	-38	5	72	5.37
Superior parietal	L	-29	-68	44	72	4.62
Superior temporal	L	-50	23	-11	52	4.10
Cerebellum	L	-5	-56	-35	48	5.70
Rostral middle frontal	R	50	44	23	41	4.65
Thalamus	L	-2	-2	8	28	3.82
Precuneus	L	-11	-62	8	28	3.97
Precentral	L	-50	8	38	28	5.17
Lateral occipital	L	-11	-104	14	26	-5.40
Supramarginal	R	65	-29	35	22	-3.83
Ventral DC	L	-2	-14	-14	20	5.80
Rostral middle frontal	L	-50	38	20	18	5.51
Main effect of stress : stress > control conditions						
Superior parietal	R	20	-92	38	42	5.11
Superior frontal	L	-2	11	38	31	4.69
Lateral occipital	R	17	-101	20	28	4.72
Insula	L	-38	-23	5	22	5.00
PCC	R	11	-26	41	20	5.11
Caudate	R	17	8	17	18	3.97
Postcentral	L	-56	-26	47	18	3.99
Main effect of WM load : high > low loads						
Amygdala	L	-17	-2	-17	29	-4.24
Superior frontal	L	-2	68	-2	18	-4.18
Interaction effect : Reward $\times$ Stress						
Rewarded > not-rewarded trials in the control condition						
Lateral occipital	L	-47	-86	-11	991	5.32
Lateral occipital	R	44	-89	-11	863	7.83
Superior frontal	R	2	53	2	379	7.15
Middle temporal	L	-59	-56	14	149	4.52
PCC	L	-2	-29	32	147	5.84
Hippocampus	L	-23	-20	-14	121	3.97
Ventral DC	R	20	-26	-8	83	5.36
Pars orbitalis	R	50	26	-14	52	4.06
Thalamus	L	-2	-2	8	38	4.30
Superior temporal	L	-47	23	-17	34	3.94
Cerebellum	R	2	-83	-38	28	3.95
Precuneus	R	8	-56	8	25	5.32
Inferior parietal	R	47	-50	56	21	4.74
Superior frontal	R	2	32	32	18	4.40

Activated clusters in brain regions	Side	MNI coordinates (LPI)			Cluster size	T-Value
		x	y	z		
Rewarded > not-rewarded trials in the stress condition						
Lateral occipital	L	-47	-86	-11	735	4.96
Lateral occipital	R	50	-68	-20	709	4.11
Superior frontal	R	2	50	11	243	5.99
Superior parietal	R	35	-65	59	82	4.15
PCC	R	2	-29	32	79	6.03
Superior parietal	L	-29	-68	47	72	5.89
Cerebellum	R	2	-83	-38	51	5.10
Cerebellum	L	-11	-56	-35	31	4.17
Inferior parietal	R	32	-74	41	25	3.83
Precentral	L	-47	5	38	22	3.81
Rostral middle central	R	50	44	23	20	4.12
Interaction effect : Reward $\times$ Load						
Rewarded > not-rewarded trials in the low load condition						
Lateral occipital	L	-47	-86	-11	1867	4.95
Superior frontal	L	-2	62	2	247	4.36
Superior parietal	L	-32	-65	56	126	3.98
PCC	R	2	-29	32	78	4.80
Superior temporal	L	-62	-35	5	74	8.13
Inferior parietal	R	44	-59	59	47	3.88
Precentral	L	-47	5	38	41	4.00
Superior parietal	R	44	-47	56	41	4.38
Insula	R	32	14	-20	26	4.08
Superior frontal	L	-2	38	23	26	4.18
Cerebellum	L	-29	-74	-47	24	4.46
Rewarded > not-rewarded trials in the high load condition						
Lateral occipital	L	-47	-86	-11	927	5.58
Lateral occipital	R	50	-68	-20	656	4.14
Rostral ACC	R	2	47	8	384	5.39
Isthmus cingulate	R	11	-53	5	110	4.57
Ventral DC	R	17	-29	-8	55	4.98
PCC	L	-2	-29	32	42	5.02
Cerebellum	R	2	-83	-38	30	4.52
Cerebellum	L	-5	-56	-35	26	5.21
Lateral orbitofrontal	R	47	23	-17	25	4.14
Rostral middle frontal	R	50	44	23	17	4.16
Interaction effect : Stress $\times$ WM load						
High > low loads in the control condition						
Superior parietal	R	38	-47	65	27	-3.90
High > low loads in the stress condition						
Superior frontal	L	-2	62	-2	50	-4.49
Amygdala	L	-17	-2	-17	31	-5.60
Hippocampus	R	23	-14	-14	19	-5.82



Activated clusters in brain regions	Side	MNI coordinates (LPI)			Cluster size	T-Value
		x	y	z		
Interaction effect : Reward × Stress × WM load						
Rewarded > not-rewarded trials in the low load and control conditions						
Lateral occipital	L	-47	-86	-11	794	4.82
Lateral occipital	R	44	-89	-11	674	6.39
Superior frontal	R	2	53	2	129	5.75
Superior temporal	L	-62	-35	5	74	6.21
Insula	L	-29	17	-8	27	4.09

*Note.* Whole-brain activations presented for every specific contrasts are corrected for multiple comparisons using a cluster-based approach with a voxelwise p-value threshold of  $p < 0.001$  and a minimum cluster size of  $k = 18$ , which corresponds to a cluster-level alpha of  $p < 0.05$ . L, left ; R, right; LPI means that x increases from Left to Right, y increases from Posterior to Anterior, z increases from Inferior to Superior.

## B. Empirical work III – Supplemental results

### B.1 Significant whole-brain activations during the anticipation phase

Table B.1

*Significant whole-brain clusters (cluster-size corrected) for the main between-subject effect of group (healthy control vs healthy vulnerable individuals), and the main within-subject effects of stress (stress vs control), reward (rewarded vs not-rewarded), and working memory (WM) load (high vs low), as well as their interactions during the anticipation phase*

Activated clusters in brain regions	Side	MNI coordinates (LPI)			Cluster size	T-Value
		x	y	z		
Main effect of stress : stress > control conditions						
Middle temporal gyrus	R	62	-53	8	40	-4.70
Cerebellum	L	-5	-86	-35	35	-3.87
Lingual	L	-2	-68	8	25	-4.46
Cuneus	R	5	-80	14	25	-3.69
Precuneus	R	2	-56	65	19	-3.73
Inferior temporal gyrus	L	-59	-62	-11	18	-3.68
Lateral occipital gyrus	R	14	-104	8	18	-3.77
Main effect of reward : rewarded > not-rewarded trials						
Inferior temporal gyrus	L	-56	-68	-14	849	4.78
Inferior temporal gyrus	R	53	-65	-17	560	5.66
Superior parietal lobule	R	23	-83	50	152	5.92
Lingual	R	2	-83	-5	85	4.44
Postcentral	L	-41	-41	65	72	4.27
Area 17 (striate area)	L	-17	-71	11	34	6.04
Putamen	L	-20	14	-11	28	4.51
Precuneus	R	5	-44	56	24	4.49
Medial orbitofrontal	R	14	47	-17	19	3.95
Inferior temporal gyrus	L	-50	-50	-26	18	3.77
Main effect of WM load : high > low loads						
Lingual	L	-14	-86	-14	3187	7.98
Superior frontal gyrus	L	-5	8	53	52	4.73
Fusiform gyrus	R	32	-44	-20	25	5.88
Insula	R	35	23	5	22	4.78
Fusiform gyrus	R	41	-53	-23	17	4.18
Pars opercularis	R	53	17	-2	17	3.89
Interaction effect : Group × Stress						
HC : control > stress conditions						
Cuneus	R	8	-83	11	41	4.26
Lateral occipital	L	-38	-86	-14	27	4.53
Superior parietal lobule	L	-20	-65	35	20	5.43
Interaction effect : Group × Reward						
HC : rewarded > not-rewarded trials						
Fusiform gyrus	L	-47	-65	-20	194	4.19
Inferior temporal gyrus	R	53	-65	-20	154	3.71
Lateral occipital gyrus	L	-29	-98	14	48	3.78
Lateral occipital gyrus	R	29	-95	23	37	4.60
Superior parietal lobule	R	26	-65	65	26	4.26
Superior parietal lobule	R	23	-83	50	22	5.09

Activated clusters in brain regions	Side	MNI coordinates (LPI)			Cluster size	T-Value
		x	y	z		
HV : rewarded > not-rewarded trials						
Lateral occipital gyrus	L	-47	-83	-14	264	3.72
Lateral occipital gyrus	R	32	-98	14	145	3.89
Superior parietal lobule	L	-23	-74	50	26	4.03
Interaction effect : Group $\times$ Load						
HC : high > low loads						
Lateral occipital gyrus	L	-5	-95	2	1213	5.82
HV : high > low loads						
Lingual gyrus	R	20	-77	-8	2437	9.19
Lingual gyrus	R	23	-50	-11	29	5.30
Fusiform gyrus	R	29	-44	-20	26	6.19
Insula	R	32	23	8	20	5.66
Postcentral	L	-50	-29	47	18	4.74
Superior frontal gyrus	L	-2	5	50	17	4.23
Interaction effect : Group $\times$ Reward $\times$ Stress						
HC : control > stress conditions in rewarded trials						
Cuneus	R	2	-74	23	24	3.95
Interaction effect : Group $\times$ Reward $\times$ Stress $\times$ WM load						
HC > HV : control condition, rewarded trials, low load						
Cuneus	R	8	-71	17	17	4.00

*Note.* Whole-brain activations presented for every specific contrasts are corrected for multiple comparisons using a cluster-based approach with a voxelwise  $p$ -value threshold of  $p < 0.001$  and a minimum cluster size of  $k = 17$ , which corresponds to a cluster-level alpha of  $p < 0.05$ . HC, healthy controls; HV, healthy vulnerable individuals; L, left ; R, right ; LPI means that x increases from Left to Right, y increases from Posterior to Anterior, z increases from Inferior to Superior.

## B.2 Significant whole-brain activations during the delivery phase

Table B.2

*Significant whole-brain clusters (cluster-size corrected) for the main between-subject effect of group (healthy control vs healthy vulnerable individuals), and the main within-subject effects of stress (stress vs control), reward (rewarded vs not-rewarded), and working memory (WM) load (high vs low), as well as their interactions during the delivery phase*

Activated clusters in brain regions	Side	MNI coordinates (LPI)			Cluster size	T-Value
		x	y	z		
Main effect of stress : stress > control conditions						
Lateral occipital gyrus	L	-26	-56	62	58	4.77
Superior parietal lobule	L	-62	-23	50	56	3.81
Postcentral	L	-29	-89	38	33	3.87
Inferior parietal lobule	L	-41	-14	59	25	4.14
Precentral	L	-41	44	35	24	3.86
Rostral middle frontal cortex	L	-26	-98	23	23	3.83
Lateral occipital gyrus	R	50	-83	-2	22	3.69
Lateral occipital gyrus	R	20	11	23	21	3.71
Caudate	L	-5	11	38	20	4.66
Superior frontal gyrus	R	38	-5	56	19	3.84
Precentral	R	68	-17	35	18	4.23
Supramarginal gyrus	L	-35	-95	14	17	3.68
Main effect of reward : rewarded > not-rewarded trials						
Lateral occipital gyrus	L	-44	-89	-14	5287	7.57
Superior frontal gyrus	L	-2	59	14	1471	7.56
Inferior parietal lobule	R	32	-74	56	429	4.07
Inferior parietal lobule	L	-32	-74	56	244	4.18
Superior temporal gyrus	R	50	23	-17	179	5.27
Lateral orbitofrontal cortex	L	-47	23	-14	170	5.75
Precentral	L	-50	8	38	92	6.01
Superior parietal lobule	L	-14	-68	59	84	-4.00
Rostral middle frontal cortex	R	53	41	20	65	3.84
Rostral middle frontal cortex	R	41	62	-8	46	5.22
Inferior parietal lobule	L	-56	-68	32	41	4.04
Middle temporal gyrus	R	65	-29	-8	31	4.42
Rostral middle frontal cortex	L	-53	32	23	29	3.96
Supramarginal gyrus	L	-68	-29	23	24	-4.08
Superior parietal lobule	R	8	-65	59	22	-3.84
Pars orbitalis	R	35	47	-17	20	3.68
Supramarginal gyrus	R	68	-32	35	17	-4.03
Main effect of WM load : high > low loads						
Lingual gyrus	R	2	-95	-11	667	-4.17
Putamen	L	-20	17	-11	200	-4.19
Lateral occipital gyrus	L	-44	-83	-17	126	-3.68
Lateral occipital gyrus	R	50	-74	-14	52	-3.95
Precentral	L	-50	5	38	31	-6.27
Postcentral	R	32	-38	44	27	-4.69
Postcentral	L	-53	-23	44	26	-4.72
Postcentral	R	53	-29	59	24	-3.97
Interaction effect : Group × Stress						
HC : stress > control conditions						
Postcentral	L	-59	-26	50	36	3.89
Superior parietal lobule	R	14	-89	44	26	5.32
Supramarginal gyrus	R	68	-35	35	24	5.12
Posterior cingulate cortex	L	-5	8	38	21	4.75
HV : stress > control conditions						
Lateral occipital gyrus	R	8	-98	17	59	4.17

Activated clusters in brain regions	Side	MNI coordinates (LPI)			Cluster size	T-Value
		x	y	z		
Interaction effect : Group $\times$ Stress						
HC : stress > control conditions						
Postcentral	L	-59	-26	50	36	3.89
Superior parietal lobule	R	14	-89	44	26	5.32
Supramarginal gyrus	R	68	-35	35	24	5.12
Posterior cingulate cortex	L	-5	8	38	21	4.75
HV : stress > control conditions						
Lateral occipital gyrus	R	8	-98	17	59	4.17
Interaction effect : Group $\times$ Reward						
HC : rewarded > not-rewarded trials						
Lateral occipital gyrus	L	-47	-71	-17	2101	6.69
Rostral anterior cingulate cortex	R	2	47	8	650	6.60
Posterior cingulate cortex	R	2	-29	32	235	8.25
Inferior parietal lobule	L	-35	-68	56	104	3.67
Inferior parietal lobule	R	35	-71	56	72	4.04
Lateral orbitofrontal cortex	R	47	26	-17	48	4.76
Middle temporal gyrus	L	-65	-35	2	48	4.32
Superior parietal lobule	R	47	-47	62	47	4.05
Cerebellum	R	8	-56	-35	38	4.98
Hippocampus	L	-23	-20	-14	30	4.98
Ventral DC	R	17	-29	-8	29	5.08
Rostral middle frontal gyrus	R	50	44	23	26	4.58
Superior parietal lobule	L	-17	-56	65	23	-4.03
Insula	L	-32	11	-20	21	3.70
HV : rewarded > not-rewarded trials						
Lateral occipital gyrus	L	-44	-86	-17	2576	6.90
Rostral anterior cingulate cortex	L	-2	44	-5	828	6.28
Pars orbitalis	R	50	38	-14	101	3.89
Superior temporal gyrus	L	-47	23	-14	93	5.17
Cerebellum cortex	R	5	-50	-35	80	6.13
Thalamus proper	R	11	-35	-2	80	5.52
Supramarginal gyrus	R	53	-44	59	75	3.89
Lingual	L	-5	-86	-20	70	4.30
Intraparietal sulcus	L	-29	-68	38	42	4.23
Thalamus proper	L	-14	-32	-2	38	4.58
Precentral	L	-50	8	38	32	4.08
Inferior parietal lobule	L	-53	-65	41	28	4.08
Superior temporal gyrus	L	-56	-44	8	25	4.86
Inferior parietal lobule	R	50	-65	50	18	3.79
Interaction effect : Group $\times$ Load						
Low load : HC > HV						
Hippocampus	R	23	-14	-23	17	5.98
HV : high > low loads						
Lateral occipital gyrus	R	29	-89	-14	386	3.82
Putamen	L	-20	17	-11	150	4.71
Lateral occipital gyrus	L	-23	-98	26	73	5.30
Lateral occipital gyrus	R	29	-92	26	32	3.71

Activated clusters in brain regions	Side	MNI coordinates (LPI)			Cluster size	T-Value
		x	y	z		
Interaction effect : Group × Reward × Stress						
HC > HV: control condition and rewarded trials						
Supramarginal gyrus	R	53	-38	44	18	-3.87
HC: stress > control conditions in rewarded trials						
Supramarginal gyrus	R	68	-35	35	33	4.57
HV: stress > control conditions in rewarded trials						
Lateral occipital gyrus	R	14	-101	20	34	3.97
Interaction effect : Group × Reward × Stress × WM load						
HC > HV: control condition, rewarded trials, high load						
Supramarginal gyrus	R	53	-35	44	24	-4.47

*Note.* Whole-brain activations presented for every specific contrasts are corrected for multiple comparisons using a cluster-based approach with a voxelwise p-value threshold of  $p < 0.001$  and a minimum cluster size of  $k = 17$ , which corresponds to a cluster-level alpha of  $p < 0.05$ . HC, healthy controls; HV, healthy vulnerable individuals; L, left; R, right; LPI means that x increases from Left to Right, y increases from Posterior to Anterior, z increases from Inferior to Superior.

## C. Project documents

### C.1 Participant information intended for healthy control participants



DÉPARTEMENT DE PSYCHOLOGIE  
PSYCHOLOGIE CLINIQUE ET PSYCHOLOGIE DE LA SANTÉ

**Prof. Dr Chantal Martin Sölch**  
Département de Psychologie  
Université de Fribourg  
Rue de Faucigny 2  
CH-1700 Fribourg

### **Déclaration de consentement écrite pour les participant-e-s avec des parents sans historique de troubles psychiques (étude transversale)**

#### **Facteurs psychobiologiques favorisant la résilience face au stress**

(Reward under stress: psychobiological mechanisms of resilience to stress)

- Veuillez lire attentivement ce formulaire.
- N'hésitez pas à poser des questions lorsque vous ne comprenez pas quelque chose ou que vous souhaitez avoir des précisions.

<b>Numéro de l'étude:</b> (au sein de la commission d'éthique compétente)	
<b>Titre de l'étude :</b>	Reward under stress: psychobiological mechanisms of resilience to stress
<b>Institution responsable (promoteur) :</b>	Université de Fribourg Département de Psychologie Rue P.-A. de Faucigny 2 1700 Fribourg
<b>Lieu de réalisation de l'étude :</b>	Université de Fribourg Département de Psychologie Hôpital Cantonal de Fribourg (HFR) InselSpital de Berne
<b>Directeur / directrice de l'étude:</b>	Prof. Dr Chantal Martin Sölch E-mail: <a href="mailto:chantal.martinsoelch@unifr.ch">chantal.martinsoelch@unifr.ch</a>

<b>Participant / participante</b>	Nom:
	Prénom:
	Date de naissance:
	<input type="checkbox"/> femme <input type="checkbox"/> homme

- Je déclare avoir été informé-e, par la personne soussignée, oralement et par écrit, des objectifs et du déroulement de l'étude sur les facteurs favorisant la résilience face au stress étudiés ainsi que des effets présumés, des avantages, des inconvénients possibles et des risques éventuels.
- J'ai reçu des réponses satisfaisantes aux questions que j'ai posées en relation avec ma participation à l'étude. Je conserve la feuille d'information datée du 06.10.2014 et reçois une copie de ma déclaration de consentement écrite. J'accepte le contenu de la feuille d'information qui m'a été remise sur l'étude précitée.

- Je prends part à cette étude de façon volontaire. Je peux, à tout moment et sans avoir à me justifier, révoquer mon consentement à participer à l'étude, sans que cela n'ait de répercussion défavorable.
- J'ai eu suffisamment de temps pour prendre ma décision.
- Je suis informé-e que l'Université de Fribourg a souscrit une assurance pour couvrir les dommages que je pourrais subir et dont je pourrai prouver qu'ils sont imputables à l'étude.
- En cas de découvertes fortuites concernant ma santé durant l'étude, je désire:
  - a)  être informé-e dans tous les cas;
  - b)  ne pas être informé-e;
  - c)  laisser la décision à la personne suivante : .....

Nous nous réservons le droit de vous informer dans tous les cas si nous devons mettre en évidence une condition grave pour votre santé afin de contribuer à son traitement et à sa prise en charge.

- Je sais que mes données personnelles peuvent être transmises à des fins de recherche uniquement sous une forme codée. J'accepte que les spécialistes compétents du mandataire de l'étude, des autorités et de la Commission d'éthique cantonale puissent consulter mes données brutes afin de procéder à des contrôles, à condition toutefois que la confidentialité de ces données soit strictement assurée.
- Je suis conscient-e que les obligations mentionnées dans la feuille d'information destinée aux participants doivent être respectées pendant la durée de l'étude. Les collaborateurs de l'étude peuvent m'en exclure à tout moment dans l'intérêt de ma santé.

Lieu, date

Signature du participant / de la participante

---



---

**Attestation de l'investigateur/l'investigatrice :**

Par la présente, j'atteste avoir expliqué au participant / à la participante la nature, l'importance et la portée de l'étude. Je déclare satisfaire à toutes les obligations en relation avec cette étude conformément au droit en vigueur. Si je devais prendre connaissance, à quelque moment que ce soit durant la réalisation de l'étude, d'éléments susceptibles d'influer sur le consentement du participant / de la participante à prendre part à l'étude, je m'engage en l'en informer immédiatement.

Lieu, date

Signature de l'investigateur/l'investigatrice

---



---



## C.2 Participant information intended for healthy vulnerable participants



DÉPARTEMENT DE PSYCHOLOGIE  
PSYCHOLOGIE CLINIQUE ET PSYCHOLOGIE DE LA SANTÉ

### Prof. Dr Chantal Martin Sölch

Département de Psychologie  
Université de Fribourg  
Rue de Faucigny 2  
CH-1700 Fribourg

## Déclaration de consentement écrite pour les participant-e-s dont l'un des parents présente un historique de dépression (étude transversale)

### Facteurs psychobiologiques favorisant la résilience face au stress

(Reward under stress: psychobiological mechanisms of resilience to stress)

- Veuillez lire attentivement ce formulaire.
- N'hésitez pas à poser des questions lorsque vous ne comprenez pas quelque chose ou que vous souhaitez avoir des précisions.

<b>Numéro de l'étude:</b> (au sein de la commission d'éthique compétente)	
<b>Titre de l'étude :</b>	Reward under stress: psychobiological mechanisms of resilience to stress
<b>Institution responsable (promoteur) :</b>	Université de Fribourg Département de Psychologie Rue P.-A. de Faucigny 2 1700 Fribourg
<b>Lieu de réalisation de l'étude :</b>	Université de Fribourg Département de Psychologie Hôpital Cantonal de Fribourg (HFR) InselSpital de Berne
<b>Directeur / directrice de l'étude:</b>	Prof. Dr Chantal Martin Sölch E-mail: <a href="mailto:chantal.martinsoelch@unifr.ch">chantal.martinsoelch@unifr.ch</a>
<b>Participant / participante</b>	Nom: Prénom: Date de naissance: <input type="checkbox"/> femme <input type="checkbox"/> homme

- Je déclare avoir été informé-e, par la personne soussignée, oralement et par écrit, des objectifs et du déroulement de l'étude sur les facteurs favorisant la résilience face au stress étudiés ainsi que des effets présumés, des avantages, des inconvénients possibles et des risques éventuels.
- J'ai reçu des réponses satisfaisantes aux questions que j'ai posées en relation avec ma participation à l'étude. Je conserve la feuille d'information datée du 06.10.2014 et reçois une copie de ma déclaration de consentement écrite. J'accepte le contenu de la feuille d'information qui m'a été remise sur l'étude précitée.

- Je prends part à cette étude de façon volontaire. Je peux, à tout moment et sans avoir à me justifier, révoquer mon consentement à participer à l'étude, sans que cela n'ait de répercussion défavorable.
- J'ai eu suffisamment de temps pour prendre ma décision.
- Je suis informé-e que l'Université de Fribourg a souscrit une assurance pour couvrir les dommages que je pourrais subir et dont je pourrai prouver qu'ils sont imputables à l'étude.
- En cas de découvertes fortuites concernant ma santé durant l'étude, je désire:
  - a)  être informé-e dans tous les cas;
  - b)  ne pas être informé-e;
  - c)  laisser la décision à la personne suivante : .....

Nous nous réservons le droit de vous informer dans tous les cas si nous devons mettre en évidence une condition grave pour votre santé afin de contribuer à son traitement et à sa prise en charge.

- Je sais que mes données personnelles peuvent être transmises à des fins de recherche uniquement sous une forme codée. J'accepte que les spécialistes compétents du mandataire de l'étude, des autorités et de la Commission d'éthique cantonale puissent consulter mes données brutes afin de procéder à des contrôles, à condition toutefois que la confidentialité de ces données soit strictement assurée.
- Je suis conscient-e que les obligations mentionnées dans la feuille d'information destinée aux participants doivent être respectées pendant la durée de l'étude. Les collaborateurs de l'étude peuvent m'en exclure à tout moment dans l'intérêt de ma santé.

Lieu, date

Signature du participant / de la participante

---

**Attestation de l'investigateur/l'investigatrice :**

Par la présente, j'atteste avoir expliqué au participant / à la participante la nature, l'importance et la portée de l'étude. Je déclare satisfaire à toutes les obligations en relation avec cette étude conformément au droit en vigueur. Si je devais prendre connaissance, à quelque moment que ce soit durant la réalisation de l'étude, d'éléments susceptibles d'influer sur le consentement du participant / de la participante à prendre part à l'étude, je m'engage en l'en informer immédiatement.

Lieu, date

Signature de l'investigateur/l'investigatrice

---

## C.3 Magnetic resonance imaging security questionnaire

Universitätsinstitut für Diagnostische und  
Interventionelle Neuroradiologie

Direktor und Chefarzt:  
Prof. Dr. med. Jan Gralla

Patientenetikette

Neuro-MR:  
Telefon +41 31 632 13 77  
Telefax +41 31 632 13 78

### QUESTIONNAIRE AUX PATIENT(E)S AVANT IMAGERIE PAR RÉSONANCE MAGNÉTIQUE (IRM)

1. Poids? ..... Taille? .....
2. Êtes-vous enceinte?  oui  non
3. Avez-vous déjà subi une opération chirurgicale?  oui  non  
(Si oui, veuillez indiquer quel type d'opération et en quelle année)  
.....  
.....
4. Portez-vous des pièces métalliques dans votre corps?  oui  non  
(Si oui, précisez quel type de métal, en quelle année et dans quelle partie du corps)  
.....  
.....
5. Etes-vous équipé(e) d'un stimulateur cardiaque (Pacemaker),  
d'une pompe à insuline, d'un stimulateur nerveux ou d'un autre  
appareil médical de ce type?  oui  non
6. Etes-vous allergique à certains médicaments ou matériaux?  oui  non
7. Avez-vous des tatouages, piercings ou du maquillage permanent?  oui  non
8. S'agit-il de votre première IRM?  oui  non

Avant d'entrer dans la zone de résonance magnétique, veuillez obligatoirement déposer les objets suivants (des casiers sont à votre disposition):

**lunettes, prothèses dentaires amovibles, appareils auditifs, patch hormonal ou anti-douleur, bijoux, montres, monnaie, cartes de crédit, stylos et clés, couteaux de poche, briquets, vêtements composés de métal, épingles à cheveux, soutien-gorge et orthèses à usage externe (par exemple ceinture herniaire). Veuillez impérativement retirer vos piercings!**

Je confirme avoir répondu en mon âme et conscience aux questions ci-dessus, avoir lu et compris les informations (page 2). Je donne mon consentement à cet examen.

Berne, le .....

.....  
Signature

## INFORMATIONS CONCERNANT L'IRM

### Informations générales

La résonance magnétique est un procédé de diagnostic permettant d'une part la réalisation de clichés du corps et fournissant d'autre part des informations supplémentaires lors d'utilisations particulières. Elle n'utilise **aucun rayon x**; l'information est obtenue par la mesure à l'aide d'antennes hypersensibles (nommées bobines) de l'excitation créée par des impulsions à haute fréquence (ondes radio) dans un **champ magnétique puissant**.

### Déroulement de l'examen

Vous devez vous déshabiller en cabine selon les indications de l'assistant(e). Durant l'examen vous serez confortablement allongé(e) sur une table et introduit(e) dans un appareil en forme de tunnel. Afin d'améliorer le contraste de l'image, l'injection de produit de contraste (gadolinium) dans une veine du bras peut s'avérer nécessaire. Durant l'examen, restez immobile et détendu(e) sur la table d'examen et ne vous laissez pas perturber par l'étroitesse du tube et les bruits émis par l'appareil (fort bruit de tambour). Certains patients réussissent parfois à s'endormir durant l'examen.

Durant la durée de l'examen, nous sommes en liaison avec vous par l'intermédiaire d'un interphone. En cas de besoin, il vous est possible de nous contacter en utilisant une sonnette.

### Mesures de précautions et questionnaire

Afin que l'examen se déroule sans danger, il convient de respecter quelques mesures de précaution. C'est pourquoi nous vous prions de répondre aux questions figurant à la page 1. Votre signature atteste de l'exactitude de vos réponses.

Remarque: si vous prenez un tranquillisant (benzodiazépine) avant l'examen, il est formellement déconseillé de prendre le volant pendant env. 12 heures.

## C.4 Ethics approval



**Commission cantonale d'éthique  
de la recherche sur l'être humain**  
Av. de Chailly 23, 1012 Lausanne

Prof. P. Francioli, Président  
Prof. R. Darioli, Past-President

Secrétariat central  
Tél. 021 316 18 30/31/32/33  
Fax 021 316 18 37  
E-mail: [secretariat.cer@vd.ch](mailto:secretariat.cer@vd.ch)

Lausanne, le 31 octobre 2014  
RD/ag

Prof. Chantal Martin Sölch  
Department of Psychology  
University of Fribourg  
Rue de Faucigny 2  
1700 Fribourg

<b>Soumission</b>	<b>24.07.2014</b>
<b>Titre</b>	<b>Facteurs psychobiologiques favorisant la résilience face au vécu de stress</b>
<b>Investigateur principal</b>	<b>Prof. Chantal Martin Sölch</b>
<b>N° du protocole</b>	<b>261/14</b>

### Décision de la Commission cantonale (VD) d'éthique de la recherche sur l'être humain (CER-VD<sup>1</sup>)

#### I. Procédure

La CER-VD a statué en :

Procédure ordinaire	<input type="checkbox"/>	
Procédure simplifiée	<input checked="" type="checkbox"/>	02.09.2014
Décision présidentielle	<input checked="" type="checkbox"/>	31.10.2014

#### II. Décision

La décision concerne: Fribourg Université de Fribourg

##### Autorisation accordée

Signification: L'étude peut commencer selon le plan de recherche accepté. Elle doit être menée dans le cadre des dispositions légales en vigueur.

Les études cliniques de catégorie B et C sont soumises aux conditions additionnelles:

1. les éventuelles remarques émises par les autorités fédérales (Swissmedic/OFSP/OFEV) ne suscitent pas de modifications des documents approuvés par la CER-VD;
2. l'autorisation des autorités fédérales (Swissmedic/OFSP/OFEV) est obtenue.

<sup>1</sup> La CER-VD s'aligne sur les principes ICH GCP.



**III. Classification** **Projet de recherche au sens de l'ORH:**

recherche sur des personnes	Catégorie	<input checked="" type="checkbox"/> A	<input type="checkbox"/> B
réutilisation du matériel biologique ou des données personnelles liées à la santé			<input type="checkbox"/>
personnes décédées			<input type="checkbox"/>
embryons et des foetus			<input type="checkbox"/>
avec rayonnements ionisants			<input type="checkbox"/>

**IV. Justifications de la décision/Remarques****V. Taxes et émoluments**

Code tarifaire	Taxe	Déjà facturé
----------------	------	--------------

**VI. Voies de recours**

La présente décision peut faire l'objet d'un recours au Tribunal cantonal, Cour de droit administratif et public. L'acte de recours doit être déposé auprès du Tribunal cantonal dans les **30 jours** suivant la communication de la décision attaquée ; il doit être signé et indiquer les conclusions et motifs du recours. La décision attaquée est jointe au recours. Le cas échéant, ce dernier est accompagné de la procuration du mandataire.

**VII. Communication au requérant, et en plus à:**

Promoteur	<input type="checkbox"/>	Swissmedic	<input type="checkbox"/>	OFSP	<input type="checkbox"/>
Autres	<input type="checkbox"/>				

**VIII. Composition de la Commission lors de la prise de décision (en annexe)**

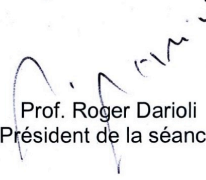
  
Prof. Roger Darioli  
Président de la séance

**Annexes :** Liste de documents  
Formulaire de rapport final

**Obligations du requérant (promoteur ou investigateur):**

1. En cas de révision, les documents ainsi que la liste de vérification actualisée sont envoyés à la CER-VD sous forme papier et CD-Rom. La liste de vérification ne répertorie que les documents révisés;
2. Les événements indésirables graves, la fin ou l'arrêt prématuré d'un essai clinique et les modifications essentielles sont annoncés selon les dispositions légales en vigueur.
3. Le rapport final est envoyé à la CER-CD dans un délai d'un an au plus tard.
4. Les essais cliniques sont enregistrés dans un registre primaire de l'OMS ([WHO-Primärregister](#)) puis dans la banque de données complémentaire de la Confédération ([Swiss National Clinical Trials Portal \[SNCTP\]](#));
5. Pro memoria: Démarche pour soumission des documents révisés:
  - Les documents révisés et la liste de vérification actualisée sont mis à disposition des commissions d'éthique sous forme digitale, et/ou un exemplaire papier.
  - La liste de vérifications répertorie uniquement les documents révisés.
  - Les modifications doivent être signalées dans les documents révisés.
  - Les documents révisés sont mis à disposition des autorités compétentes pour approbation.



**Commission cantonale d'éthique  
de la recherche sur l'être humain**  
Av. de Chailly 23, 1012 Lausanne

## FORMULAIRE DE RAPPORT FINAL

<b>Protocole 261/14</b> : Facteurs psychobiologiques favorisant la résilience face au vécu de stress
<b>Date d'acceptation par la Commission cantonale (VD) d'éthique</b> : 31.10.2014
<b>Investigateur responsable</b> : Prof. Chantal Martin Sölch Department of Psychology University of Fribourg Rue de Faucigny 2 1700 Fribourg

Date de la fin de l'étude sur votre site (date de la dernière visite du dernier patient/sujet) : .....

L'étude a-t-elle été annulée avant inclusion de sujets/patients ou arrêtée en cours de route ?  oui  
 non

Si OUI, pourquoi? : .....  
.....

### Sur votre site :

- quel est le nombre de patients/sujets inclus : .....
- quel est le nombre d'échecs à l'inclusion : .....
- quel est le nombre de drop-out en cours d'étude : .....
- quel est le nombre de patients/sujets ayant complété l'étude : .....
- Y a-t-il eu des incidents/effets indésirables graves pendant l'étude?  oui  non

Si OUI, lesquels?  
.....  
.....  
.....

Conclusions qui peuvent être tirées de l'étude à votre niveau :  
.....  
.....  
.....

En cas de publication, prière d'adresser un tiré-à-part

**En cas d'étude multicentrique**, celle-ci est-elle encore en cours ?  oui  non

Date présumée de la fin de l'étude: .....

**Date:** ..... **Signature de l'investigateur:** .....

**A retourner au:** Président de la Commission cantonale (VD) d'éthique de la recherche sur l'être humain,  
Secrétariat central, Av. de Chailly 23, 1012 Lausanne





# CURRICULUM VITAE

---

## Claudie Gaillard

✉ claudie.gaillard@unifr.ch

ORCID : 0000-0001-9199-7974

Date of birth: 01.04.1989

Nationality: Swiss

### ACADEMIC POSITIONS

---

- 2013 - now**      **Teaching assistant**  
Unit of Clinical and Health Psychology, Department of Psychology, University of Fribourg, Fribourg, Switzerland
- 11.2017 – 05.2018**      **Research fellow (Special Volunteer) with Dr. med. Monique Ernst**  
Section on Neurobiology of Fear and Anxiety (SNFA), National Institutes of Mental Health (NIMH), Bethesda, Maryland, USA
- 10.2013 – 10.2014**      **Psychologist assistant with Dr. France Frascarolo-Moutinot**  
Research Unit of the Center for Family Study, Lausanne University Hospital (CHUV), Vaud, Switzerland
- 09.2012 – 09.2013**      **Undergraduate teaching assistant for Bachelor statistics seminar with Dr. Pascal Wagner-Egger**  
Department of Psychology, University of Fribourg, Fribourg, Switzerland
- 09.2012 – 09.2013**      **Undergraduate research assistant with Prof. Dr. Valérie Camos**  
Unit of Developmental Psychology, Department of Psychology, University of Fribourg, Fribourg, Switzerland

### EDUCATION

---

- 2013 - now**      **PhD student in clinical psychology and affective neurosciences under the supervision of Prof. Dr. Chantal Martin Soelch**  
Unit of Clinical and Health Psychology, Department of Psychology, University of Fribourg, Fribourg, Switzerland
- 2013 - now**      **Doctoral Program of Psychology, Western Switzerland**  
Conférence Universitaire de Suisse Occidentale (CUSO)

**02.2014 – 10.2016 Diploma of Advanced Studies in Academic Education and Technology of Education**

Center of Academic Didactic, University of Fribourg, Fribourg, Switzerland

**09.2011 – 10.2013 Master of Science in Clinical and Health Psychology**

Department of Psychology, University of Fribourg, Fribourg, Switzerland

- ♦ Master thesis : “ Etude auprès de personnes souffrant de douleurs chroniques: facteurs cognitifs favorisant la chronicisation des douleurs. Le lien entre catastrophisation, hypervigilance attentionnelle et rumination dans l'émergence d'une vulnérabilité face au processus de chronicisation de la douleur [ Influence of cognitive factors in chronic pain : relation between catastrophization, hypervigilance and rumination in increased vulnerability to chronicization of the pain ] ”.

Master degree obtained with *Insigni cum Laude*

**09.2011 - 02.2012 Erasmus**

Department of Psychology, University of Heidelberg, Bade-Wurtemberg, Germany

**09.2008 – 08.2011 Bachelor of Science in Psychology**

Department of Psychology, University of Fribourg, Switzerland

- ♦ Bachelor thesis : “ La mémoire de travail chez les bilingues: Y a-t-il un avantage du bilinguisme dans la gestion du switching attentionnel au sein de la mémoire de travail ? [ Working memory in bilinguals : is there an advantage of bilingualism in attentional switching within working memory ? ] ”.

Bachelor degree obtained with *Insigni cum Laude*

**09.2004 – 09.2008 High school diploma – Option ‘Biology and Chemistry’**

Collège du Sud, Bulle, Switzerland

## **MAJOR SCIENTIFIC ACHIEVEMENTS**

---

### **PUBLICATIONS**

**Gaillard, C.**, Guillod, M., Ernst, M., Torrisi, S., Federspiel, A., Schoebi, D., Recabarren, R. E., Ouyang, X., Mueller-Pfeiffer, C., Horsch, A., Wiest, R., Hasler, G., & Martin-Soelch, C. (submitted). Striatal responsiveness to reward under threat-of-shock and working memory load. *Brain and Behavior*.

**Gaillard, C.**, Guillod, M., Ernst, M., Torrisi, S., Federspiel, A., Schoebi, D., Recabarren, R. E., Ouyang, X., Homan, P., Mueller-Pfeiffer, C., Horsch, A., Wiest, R., Hasler, G., & Martin-Soelch, C. (in preparation). Ventral striatal reactivity to reward is negatively associated with maladaptive emotion regulation and depressive symptomatology.

**Gaillard, C.**, Guillod, M., Ernst, M., Torrìsi, S., Federspiel, A., Schoebi, D., Recabarren, R. E., Ouyang, X., Homan, P., Mueller-Pfeiffer, C., Horsch, A., Wiest, R., Hasler, G., & Martin-Soelch, C. (in preparation). Striatal reactivity to reward under threat-of-shock and working memory load in adults at increased familial risk for major depression.

Ernst, M., Gowin, J., **Gaillard, C.**, Philips, R. & Grillon, C. (2019). Sketching the power of machine learning to decrypt a neural systems model of behavior. *Brain Sciences*, 9(67), 1-17.  
DOI: [10.3390/brainsci9030067](https://doi.org/10.3390/brainsci9030067)

Recabarren, R. E., **Gaillard, C.**, Guillod, M., & Martin-Soelch, C. (2019). Short-term effects of a multidimensional stress prevention program on quality of life, well-being and psychological resources. A randomized control trial. *Frontiers in Psychiatry*, 10(88), 1-15.  
DOI: [10.3389/fpsyt.2019.00088](https://doi.org/10.3389/fpsyt.2019.00088)

## TALK

**Gaillard, C.**, Guillod, M., Schoebi, D., Federspiel, A., Recabarren, R., Ouyang, X., Mueller-Pfeiffer, C., Horsch, A., Hasler, G., & Martin-Soelch, C. (2018). Rôle du stress et de l'effort cognitif sur la sensibilité à la récompense. Talk presented at the International multidisciplinary Symposium for Gambling addiction: Science, Independence, Transparency, Fribourg, Switzerland.  
DOI: [10.13140/RG.2.2.24853.99042](https://doi.org/10.13140/RG.2.2.24853.99042)

## POSTERS

**Gaillard, C.**, Guillod, M., Ernst, M., Torrìsi, S., Federspiel, A., Schoebi, D., Recabarren, R. E., Ouyang, X., Mueller-Pfeiffer, C., Horsch, A., Wiest, R., Hasler, G., & Martin-Soelch, C. (2019). Striatal responsivity to reward cues under stress and working memory load : insights for the vulnerability to major depression. Poster presented at the Stress Meeting, Basel, Switzerland.  
DOI: [10.13140/RG.2.2.27742.48967](https://doi.org/10.13140/RG.2.2.27742.48967)

Guillod, M., **Gaillard, C.**, Recabarren, R. E., Schoebi, D., Gomez P., Horsch, A., Federspiel, A., Mueller-Pfeiffer, C., Merlo, M.C.G., Homan, P., Hasler, G., Martin-Soelch, C. (2019). Objective and subjective dimensions of reward and stress experiences : Correlations between fMRI and daily life self-reported data. Poster presented at the Stress Meeting, Basel, Switzerland.  
DOI: [10.13140/RG.2.2.33571.91683](https://doi.org/10.13140/RG.2.2.33571.91683)

Recabarren, R. E., **Gaillard, C.**, Guillod, M., Martin-Soelch, C. (2019). Resilient against stress. Effects of a stress prevention program on indicators of well-being, and psychological resources in university students. Poster presented at the Stress Meeting, Basel, Switzerland.

**Gaillard, C.**, Guillod, M., Federspiel, A., Schoebi, D., Recabarren, R. E., Ouyang, X., Mueller-Pfeiffer, C., Horsch, A., Hasler, G., & Martin-Soelch, C. (2017). Influence of stress on altered reward processing during reward anticipation and delivery. Poster presented at the Society for Neuroscience (SfN) meeting, Washington DC, USA.  
DOI: [10.13140/RG.2.2.26153.49763](https://doi.org/10.13140/RG.2.2.26153.49763)

**Gaillard, C.**, Guillod, M., Schoebi, D., Federspiel, A., Recabarren, R., Ribeiro, S., Hsieh-Meister, K., Mueller-Pfeiffer, C., Horsch, A., Hasler, G., & Martin-Soelch, C. (2017). Adaptative emotion regulation modulates the impact of stress on reward sensitivity. Poster presented at the Swiss Psychological Society meeting (SPS), Lausanne, Switzerland.  
DOI: [10.13140/RG.2.2.22798.05445](https://doi.org/10.13140/RG.2.2.22798.05445)

Guillod, M., **Gaillard, C.**, Recabarren, R., Schoebi, D., Merlo, M., Hasler, G., Martin-Soelch, C. (2017). Measures of daily mood, stress and reward responses in offspring of depressed parents. Poster in preparation for presentation at the 13th WFSBP meeting (World Congress of Biological Psychiatry), Copenhagen, Denmark.  
DOI: [10.13140/RG.2.2.17633.56168](https://doi.org/10.13140/RG.2.2.17633.56168)

**Gaillard, C.**, Guillod, M., Federspiel, A., Recabarren, R., Hsieh-Meister, K., Schoebi, D., Ouyang, X., Mueller-Pfeiffer, C., Horsch, A., Hasler, G., & Martin-Soelch, C. (2016). Reward, stress and performance : an fMRI study of reward processing under stress. Poster presented at the Organization for Human Brain Mapping (OHBM) meeting, Geneva, Switzerland.  
DOI: [10.13140/RG.2.2.15626.52162](https://doi.org/10.13140/RG.2.2.15626.52162)

Recabarren, R. E., **Gaillard, C.**, Guillod, M., & Martin-Soelch, C. (2016). Effects of a prevention stress program on mindfulness skills among university students in Switzerland. Poster presented at the 46th Annual Congress of the European Association for Behavioral and Cognitive Therapies (EABCT), Stockholm, Sweden.

## GRANT

**11.2017-05.2018 Doc.Mobility fellowship** CHF 25'320  
Swiss National Science Foundation (SNSF)

- ♦ Awarded for the project “Reward under stress: Searching for psychobiological and neural vulnerability factors to stress” (no. P1FRP1\_174818) realized during a research stay at the National Institutes of Mental Health (NIMH), Bethesda, Maryland, USA.

## **TEACHING ACTIVITIES**

---

- 2014 - now      **Master teachings**
- ♦ “ Diagnostic : Conduite d’entretiens structurés ” (Fall semester)
  - ♦ “ Méthodes psycho-corporelles et mindfulness : indications et applications en psychologie clinique et de la santé ” (Spring semester)

## **SUPERVISION**

---

- 2013 - now      **Co-supervision of Master theses in collaboration with Prof. Dr. Chantal Martin Soelch**  
Valérie Brunisholz, Debora de Felice, Marjolaine Guillet, Mireille Régis, and Nathalie Wagnon.
- 2013 - now      **Co-supervision of Bachelor theses in collaboration with Prof. Dr. Chantal Martin Soelch**  
Laura Cardoso, Helena Chapuis, Laryssa Grosjean, Marie-Josée Meuwly, Benjamin Nunez, and Danilo Tuzzolino.
- 2013 - now      **Supervision of interns**  
Melanie El-Khoury, Marie-Josée Meuwly, Nadia Nadeem, Céline Rappaz, Sandra Ribeiro, Marc Rothlisberger, Aurélie Schneiter, and Morgane Vouillamoz.

## **INSTITUTIONAL RESPONSIBILITIES**

---

- 09.2016 – 10.2017      **Member representative**  
Department of Psychology, Ethic Commission

## **MEMBERSHIPS**

---

- 01.2014 - 03.2015      **Board member of the Association Fribourgeoise des Psychologues**  
AFP/FPV
- 09.2011 - 06.2013      **psyCH board member**  
Swiss Association of Students in Psychology
- 08.2010 - 09.2011      **AGEF (University Fribourg students association) board member**  
University of Fribourg

## **INTERNSHIPS**

---

- 07.2011 - 09.2011 Undergraduate psychologist assistant**  
HorizonSud Foundation (Residence specialized in the care of psychological disorders), Les Sciernes d'Albeuve, Switzerland
- 10.2009 - 03.2010 Undergraduate research assistant**  
Unit of Clinical and Health Psychology, Department of Psychology, University of Fribourg, Fribourg, Switzerland
- 06.2019 – 09.2009 Undergraduate psychologist**  
Unit of acute care, Mental Hospital of Nant Foundation, Nant, Switzerland

## **SKILLS**

---

### **INFORMATICS**

General softwares : Word, Power point, Excel, Endnote, Mendeley, Zotero.  
Statistical softwares : SPSS, HLM.  
Analysis of brain imaging data sequences : AFNI, SPM12.  
Computerized experiment software : E-Prime.

### **LANGUAGES**

French : Native speaker  
English : Advanced, spoken and written  
German : Advanced, spoken and written

Fribourg, June 2019

## LIST OF PUBLICATIONS

---

**Gaillard, C.**, Guillod, M., Ernst, M., Torrisi, S., Federspiel, A., Schoebi, D., Recabarren, R. E., Ouyang, X., Mueller-Pfeiffer, C., Horsch, A., Wiest, R., Hasler, G., & Martin-Soelch, C. (under review). Striatal responsiveness to reward under threat-of-shock and working memory load. *Brain and Behavior*.

**Gaillard, C.**, Guillod, M., Ernst, M., Torrisi, S., Federspiel, A., Schoebi, D., Recabarren, R. E., Ouyang, X., Homan, P., Mueller-Pfeiffer, C., Horsch, A., Wiest, R., Hasler, G., & Martin-Soelch, C. (in preparation). Ventral striatal reactivity to reward is negatively associated with maladaptive emotion regulation and depressive symptomatology.

**Gaillard, C.**, Guillod, M., Ernst, M., Torrisi, S., Federspiel, A., Schoebi, D., Recabarren, R. E., Ouyang, X., Homan, P., Mueller-Pfeiffer, C., Horsch, A., Wiest, R., Hasler, G., & Martin-Soelch, C. (in preparation). Striatal reactivity to reward under threat-of-shock and working memory load in adults at increased familial risk for major depression.

Ernst, M., Gowin, J., **Gaillard, C.**, Philips, R. & Grillon, C. (2019). Sketching the power of machine learning to decrypt a neural systems model of behavior. *Brain Sciences*, 9(67), 1-17.  
DOI: [10.3390/brainsci9030067](https://doi.org/10.3390/brainsci9030067)

Recabarren, R. E., **Gaillard, C.**, Guillod, M., & Martin-Soelch, C. (2019). Short-term effects of a multidimensional stress prevention program on quality of life, well-being and psychological resources. A randomized control trial. *Frontiers in Psychiatry*, 10(88), 1-15.  
DOI: [10.3389/fpsy.2019.00088](https://doi.org/10.3389/fpsy.2019.00088)





Je déclare sur mon honneur que ma thèse est une œuvre personnelle, composée sans concours extérieur non autorisé, et qu'elle n'a pas été présentée devant une autre Faculté.

Claudie Gaillard