

51. IWK
Internationales Wissenschaftliches Kolloquium
International Scientific Colloquium



PROCEEDINGS

11-15 September 2006

**FACULTY OF ELECTRICAL ENGINEERING
AND INFORMATION SCIENCE**



**INFORMATION TECHNOLOGY AND
ELECTRICAL ENGINEERING -
DEVICES AND SYSTEMS,
MATERIALS AND TECHNOLOGIES
FOR THE FUTURE**

Startseite / Index:

<http://www.db-thueringen.de/servlets/DocumentServlet?id=12391>

Impressum

Herausgeber: Der Rektor der Technischen Universität Ilmenau
Univ.-Prof. Dr. rer. nat. habil. Peter Scharff

Redaktion: Referat Marketing und Studentische
Angelegenheiten
Andrea Schneider

Fakultät für Elektrotechnik und Informationstechnik
Susanne Jakob
Dipl.-Ing. Helge Drumm

Redaktionsschluss: 07. Juli 2006

Technische Realisierung (CD-Rom-Ausgabe):
Institut für Medientechnik an der TU Ilmenau
Dipl.-Ing. Christian Weigel
Dipl.-Ing. Marco Albrecht
Dipl.-Ing. Helge Drumm

Technische Realisierung (Online-Ausgabe):
Universitätsbibliothek Ilmenau
[ilmedia](#)
Postfach 10 05 65
98684 Ilmenau

Verlag:  Verlag ISLE, Betriebsstätte des ISLE e.V.
Werner-von-Siemens-Str. 16
98693 Ilmenau

© Technische Universität Ilmenau (Thür.) 2006

Diese Publikationen und alle in ihr enthaltenen Beiträge und Abbildungen sind urheberrechtlich geschützt. Mit Ausnahme der gesetzlich zugelassenen Fälle ist eine Verwertung ohne Einwilligung der Redaktion strafbar.

ISBN (Druckausgabe): 3-938843-15-2
ISBN (CD-Rom-Ausgabe): 3-938843-16-0

Startseite / Index:
<http://www.db-thueringen.de/servlets/DocumentServlet?id=12391>

H. Toepfer, P. Febvre, Th. Ortlepp, F.H. Uhlmann

Electromagnetic Analysis of Photosensitive Interfaces for Rapid Single Flux Quantum Circuit Applications

ABSTRACT

Rapid Single-Flux-Quantum (RSFQ) circuit technique is officially recognized to be a key component of the mid-term future of digital electronics [1]. It combines in a unique manner the possibility of clock rates in the range well above 20-50GHz with extremely low power consumption. In this contribution, efforts towards the development of an optical-to-RSFQ interface will be introduced. After an introduction to the approach for electromagnetic analysis, a particular coupling structure will be described in terms of its electromagnetic response. It will be shown how the functional requirements can be met under consideration of a particular fabrication technology so that feasibility is achieved on the design and simulation level, respectively.

INTRODUCTION

Rapid Single-Flux-Quantum technology for information processing is inherently fast. For the emerging superconducting Niobium technology, a set of integrated circuits has been designed and tested within the European FLUXONICS [2] initiative for the development of digital superconductive integrated electronic circuits. The system performance is still limited by the bandwidth at the borders to the conventional electronics periphery. In order to provide a solution for triggering RSFQ circuits, the design of an photosensitive optical-to-RSFQ interface is proposed. Since a review of basic effects and mechanisms taking place in superconductive optoelectronics can be found in [3], this paper will focus on the development of an integrated photoswitch. The circuit described here is intended to fill the gap of the very rapid signal interface which is not hitherto available.

The design work aims at a realization in integrated Niobium technology of the JeSEF foundry [4] and is therefore subject to certain design rules [5]. Although the basic assumptions were well-posed, severe constraints, resulting from the lithographic

resolution of the fabrication process, imposed the need for a thorough analysis of the set-up by means of electromagnetic CAD approaches.

TIME-DOMAIN ELECTROMAGNETIC ANALYSIS AND DESIGN OF A LASER-OPTICAL INTERFACE

The electromagnetic task consisted in the design of an integrated structure that propagates a laser-induced voltage pulse into an RSFQ circuit in such a way that the interfacing Josephson junctions are caused to respond to it in a similar manner as they would react to an RSFQ voltage pulse. This is mainly an issue involving high-frequency design approaches. Because of the fact that the information is coded by single voltage pulses of approximately 5ps in duration, frequency-domain microwave analysis as provided by most of the commercial software packages is not appropriate. Instead, the Finite-Difference Time-Domain (FDTD) method is used for this purpose. This technique is based on the calculation of the time evolution of electric and magnetic fields, respectively. By applying a Fourier transform to the structure's response to a probing pulse, a broadband characterization can be achieved. Thus, only one simulation run is necessary. This simplifies the analysis procedure considerably. For the purpose of the electromagnetic design of integrated superconducting structures, the material properties are described phenomenologically in the framework of the two-fluid model using a frequency-dependent complex permittivity. The implementation into a standard FDTD algorithm required the conversion of this model description into the time domain and was done using a recursive convolution procedure [6]. From former studies [7], it is well-known that gaps in coplanar waveguide structures do not constitute a problem for the propagation of RSFQ pulses. This is due to their large bandwidth. The idea behind this novel device is to have a nearly-coplanar section where the laser pulse interacts with the material of the superconductor. Due to this interaction, the voltage pulse is coupled to a microstrip-line part and further propagated to the RSFQ circuit.

The geometrical modeling focused on this particular section and contains both the gap in the coplanar waveguide and the step in height of the coplanar-to-microstrip transition as the the crucial points under investigation. Fig. 1 shows the resulting CAD drawing of the structure.

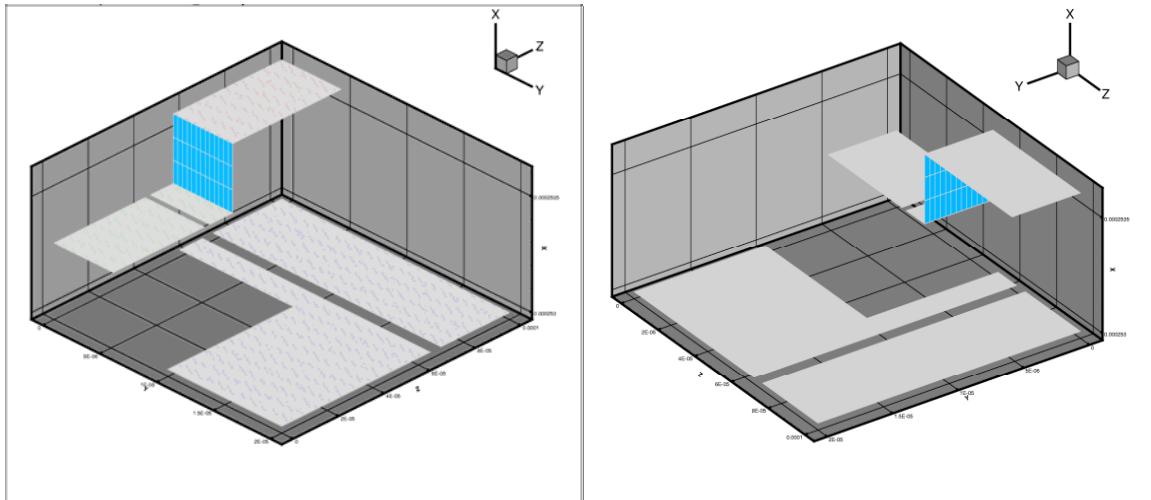

Figure 1: Schematic representation of the structure under investigation as discretized for the calculation. The coplanar-like section near the origin is converted to a microstrip line section (the step in height further in z-direction). DC isolation is achieved by a gap in the center coplanar line.

In the simulation, the structures were excited by a Gaussian pulse. As the goal consisted in deriving information relevant for RSFQ systems, the pulse width of 5ps has been chosen which led to a bandwidth of 200GHz. By means of these simulation studies, a geometrical set-up has been found which meets the requirements on a high-speed optical-to-electrical interface circuit. The propagation characteristics of a resulting structure are illustrated in Figure 2. It shows the propagated pulses for the y - and x -components of the electric field strengths, respectively. It turns out that – though attenuated – the pulses are propagated across the gap in the coplanar structure as well as along the coplanar-to-microstrip transition.

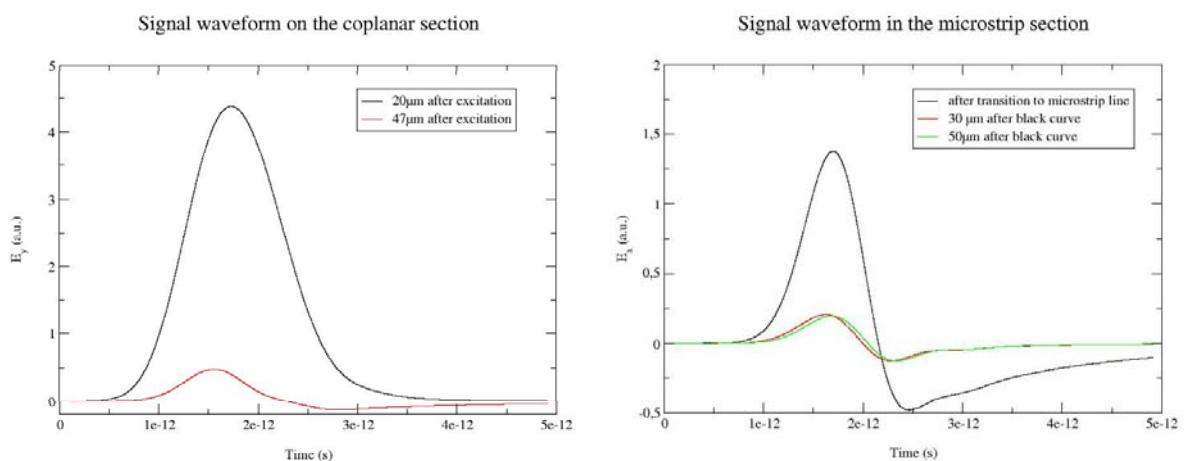

Figure 2: Electrical field as calculated with the FDTD method: Left side: y -component in the coplanar section, right side: x -component in the microstrip line section.

As a result, an interface prototype has been defined and characterized through a numerical computation of the electromagnetic field. Fig.3 shows the layout of the photoswitch cell which has been elaborated on the basis of the design considerations described above.

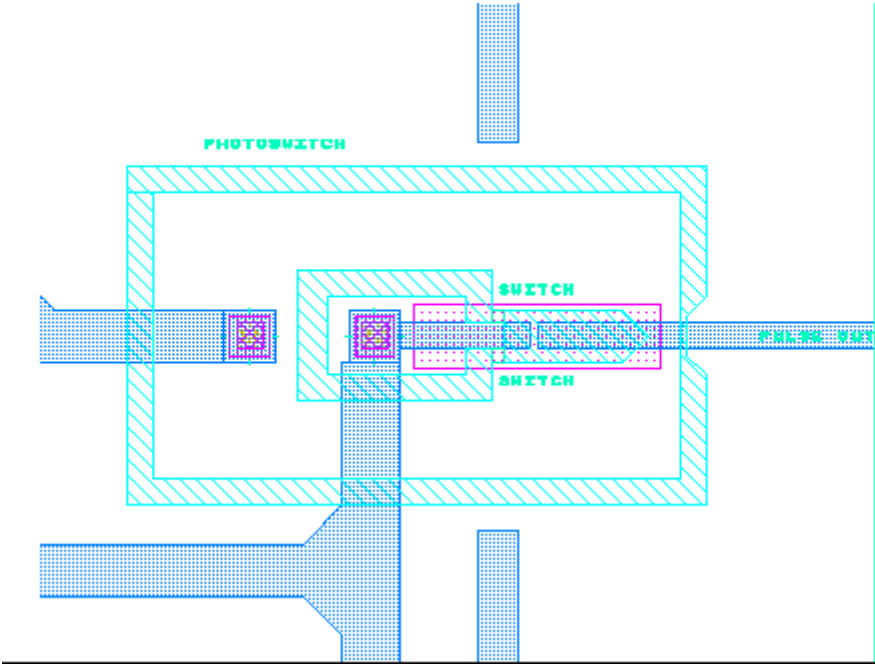

Figure 3: CAD drawing of the laser-to-RSFQ interface layout

A first realization is shown in Fig.4. Slight changes have been introduced due to technological constraints.

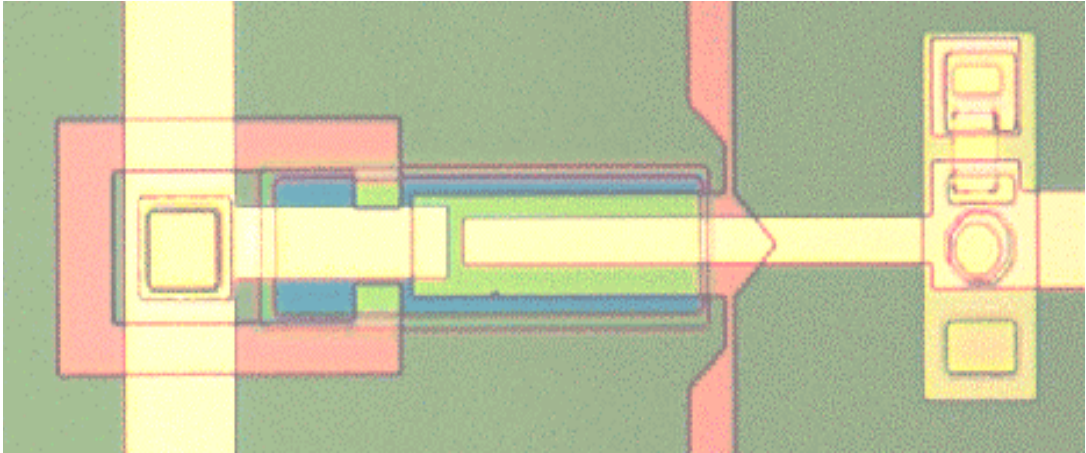

Figure 4: Realization of a Laser-optical interface in the Niobium technology of [4].

CONCLUSION

A prototype for a fast photosensitive interface for application in RSFQ circuits has been defined and characterized by means of numerical computation of the electromagnetic field. By means of simulation studies, a geometrical set-up has been found which is both performant and compliant with existing design rules for circuit integration. The preparations for high-speed tests of the devices already fabricated are under way. Results of the experiments will be subject to further publication.

References:

- [1] International Technology Roadmap for Semiconductors 2004 Update: www.itrs.net/Common/2004Update.htm
- [2] www.fluxonics.org
- [3] M. Tonouchi, M. Hangyo, Superconductive Optoelectronics. FED Journal 9(1998) Suppl. 2, pp. 41 – 47
- [4] www.cryo-jena.de/
- [5] Rapid Single Flux Quantum (RSFQ) Design Rules for Nb/Al₂O₃-Al-Nb Process at JeSEF, IPHT Jena, Germany http://www.ipht-jena.de/BEREICH_1/abt13_cryo_electronics/technology-data/rsfq.php
- [6] H.Toepfer, Th. Lingel, F.H. Uhlmann, Application of the FDTD method for investigating the propagation of ps-pulses in superconducting structures, Proc. 43rd Internationales Wissenschaftliches Kolloquium, Vol. 3, Technical University of Ilmenau 1998, pp. 209-214
- [7] H.Toepfer, Th. Lingel, F.H. Uhlmann, Characterization of pulse propagation across discontinuities in RSFQ systems. Proc. 6th International Superconductive Electronics Conference ISEC'97, June 25-27, 1997, Berlin, pp. 3232 – 325

Authors:

PD Dr.-Ing. habil. Hannes Töpfer
Institut für Mikroelektronik- und Mechatronik-Systeme (IMMS) gGmbH
System Design Department
Ehrenbergstraße 27
D-98693 Ilmenau
Germany
Phone: +49 (0)3677 69 55 40
Fax: +49 (0)3677 69 55 15
E-mail: hannes.toepfer@imms.de

Dr. Pascal Febvre
LAHC
Laboratoire d'Hyperfréquences et de Caractérisation
Université de Savoie
Bâtiment Chablais,
73376 Le Bourget du Lac Cedex
France
Phone: +33 4 79 75 88 64
Fax: +33 4 79 75 87 42
E-mail: pascal.febvre@univ-savoie.fr

Dr.-Ing. Dipl.-Math. Thomas Ortlepp, Univ.-Prof. Dr.-Ing. habil. F.H. Uhlmann
Technical University of Ilmenau
Dept. of Fundamentals and Theory of Electrical Engineering
P.O. Box 100 565
D-98684 Ilmenau
Germany
Phone: +49 (0)3677 69 26 29
Fax: +49 (0)3677 69 26 32
E-mail: thomas.ortlepp@tu-ilmenau.de, hermann.uhlmann@tu-ilmenau.de