

54. IWK
Internationales Wissenschaftliches Kolloquium
International Scientific Colloquium



**Information Technology and Electrical
Engineering - Devices and Systems, Materials
and Technologies for the Future**



Faculty of Electrical Engineering and
Information Technology

Startseite / Index:

<http://www.db-thueringen.de/servlets/DocumentServlet?id=14089>

Impressum

Herausgeber: Der Rektor der Technischen Universität Ilmenau
Univ.-Prof. Dr. rer. nat. habil. Dr. h. c. Prof. h. c.
Peter Scharff

Redaktion: Referat Marketing
Andrea Schneider

Fakultät für Elektrotechnik und Informationstechnik
Univ.-Prof. Dr.-Ing. Frank Berger

Redaktionsschluss: 17. August 2009

Technische Realisierung (USB-Flash-Ausgabe):
Institut für Medientechnik an der TU Ilmenau
Dipl.-Ing. Christian Weigel
Dipl.-Ing. Helge Drumm

Technische Realisierung (Online-Ausgabe):
Universitätsbibliothek Ilmenau
[ilmedia](#)
Postfach 10 05 65
98684 Ilmenau

Verlag:



Verlag ISLE, Betriebsstätte des ISLE e.V.
Werner-von-Siemens-Str. 16
98693 Ilmenau

© Technische Universität Ilmenau (Thür.) 2009

Diese Publikationen und alle in ihr enthaltenen Beiträge und Abbildungen sind urheberrechtlich geschützt.

ISBN (USB-Flash-Ausgabe): 978-3-938843-45-1
ISBN (Druckausgabe der Kurzfassungen): 978-3-938843-44-4

Startseite / Index:

<http://www.db-thueringen.de/servlets/DocumentServlet?id=14089>

EMC-REQUIREMENTS ON MODERN SURGE PROTECTIVE DEVICES

Michael Naß* / Jens Schönau* / Arnd Ehrhardt⁺

^{*)} CE-LAB GmbH, Am Hammergrund 1
98693 Ilmenau / Germany
Phone: 03677 / 6479-80
Fax: 03677 / 6479-89
E-mail: j.schoenau@ce-lab.de

⁺⁾ DEHN+SÖHNE GmbH + Co.KG, Hans-Dehn-Str. 1
92306 Neumarkt / Germany
Phone: 09181 / 906-404
Fax: 09181 / 906-312
E-mail: arnd.ehrhardt@technik.dehn.de

ABSTRACT

A new generation of Surge Protective Devices (SPD's) shall not only perform the protecting task, furthermore fault analyses or monitoring functions are of great importance for their safe and reliable function. Especially the SPD type 1 arrester DEHNlimit PV, which is designed for the lightning and over-voltage protection of Photovoltaic (PV) modules, can't waive an electronic control of the designated function cycle. The present paper describes the requirements regarding to electromagnetic compatibility (EMC) for such modern surge protective devices with internal electronic control elements.

Index Terms – Electromagnetic Compatibility, Surge protection, Immunity, Photovoltaic

1. BASIC FUNCTION OF DEHNlimit

The Surge protective device DEHNlimit PV is accurate designed in structure and function according to the requirements of application in PV-installations. As a spark-gap based combined lightning current and surge arrester it is able to conduct high energy surge currents with a shape of $T_1/T_2 = 10/350 \mu\text{s}$ up to maximum values of 25 kA per protective path safe an secure (SPD Type 1-protective device) [1].

With a guaranteed protection level of $\leq 3,3 \text{ kV}$ (protection path $L+ \rightarrow L-$) respectively $\leq 4 \text{ kV}$ (protection path $L+/L- \rightarrow \text{PE}$) it corresponds to protection requirements of usual PV-generator-circuits [2]. Due to the design for a highest continuous voltage rating of 1000 Vdc it is usable without any problems even in larger PV-installations with extensive Strings and a corresponding high maximal system voltage. Based on a design as a spark-gap arrester with a bypass quenching circuit it was possible to use these powerful arrester technology even in DC-circuits of PV-installations with the well known features of the DC circuit breaker mechanism.

Only by using a suitable electronic control unit it is possible to achieve this task. The control unit fulfils the task of the condition monitoring during respond as well as control of the bypass-unit. The main task of the control unit is to separate a surge current as a result of a lightning discharge from the follow current of the PV-generator [3]. At a surge current amplitude the spark-gap is used to arrest the complete current (trigger). The bypass circuit get a trigger signal if a DC-current is detected and is used as a spark quenching unit (breaking).

The necessary power supply is provided directly by the PV-generator. This is not a real loading of the generator because the current consumption is in the range of $< 5 \text{ mA}$.

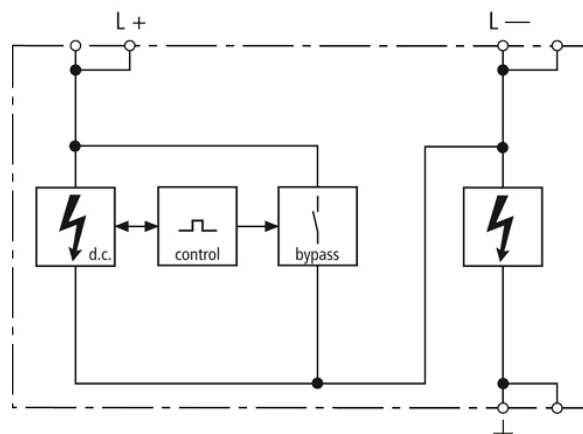

Figure 1 – basic circuit of DEHNlimit PV

Figure 1 shows the surge protective device and the basic circuit of DEHNlimit PV. A typical current and voltage diagram for an arrester and quenching event is shown in figure 2.

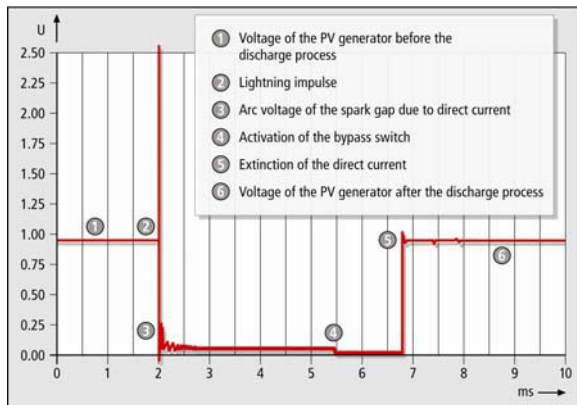

Figure 2 – basic function of DEHNlimit PV

2. TEST REQUIREMENTS FOR SURGE PROTECTIVE DEVICES

Surge Protective Devices (SPD's) for application in low-voltage installations are in general part of classic installation devices. As electrical equipment designed for use within certain voltage limits, these devices are subject to the European Low-Voltage directive 2006/95/EC [4]. For SPD's EN 61643-11 is a harmonised product standard [5] for the conformity assessment process to fulfil the safety requirements. A Declaration of Conformity (DoC) is the requirement for labelling of products with the CE-mark to allow a free movement of goods within the single European market.

Correspondingly EN 61643-11 is as harmonized product standard listed inside the Official Journal (OJ) of the European Union and the application is mandatory. Due to the use of electronic components inside the electrical equipment also the EMC-directive 2004/108/EC [6] has to be taken into consideration. Currently there is no special EMC product or productfamily standard available for SPD's. Therefore generic EMC standards are to select and to apply. Because of the typical environmental conditions of the devices it is indicated to apply the standards EN 61000-6-2 (Immunity) and EN 61000-6-4 (Emission) for a typical industrial application [7, 8].

EN 61643-11 as a safety standard for surge protective devices includes in section 7.10 „Type Test - Electromagnetic Compatibility“ EMC-relevant requirements for these electrical apparatus but neither definite requirements nor detailed test parameters are given. These parts of the standard are currently under discussion. If all EMC aspects are in future detailed

and product specific included in EN 61643-11 it is to expect to harmonize this standard also under the EMC-Directive 2004/108/EC. Currently it belongs to the manufacturer to select all applicable EMC-requirements under consideration of the environmental condition for the surge protective devices. Typically manufacturers are using EMC-test labs to get assistant for the right selection of standards and test procedures. In the case of the DEHNlimit PV module the EMC-Test laboratory of CE-LAB GmbH in Ilmenau there used [9].

3. EMC ASSESSMENT

EMC-Test Labs are generally equipped with special test benches to perform compliance tests regarding all requirements of the EMC-standards under well known test conditions. Because of the normal operation condition of the Equipment Under Test (EUT) in PV-installations all EMC-test has to be performed with the maximum voltage rating of 1000 Vdc. This is a unusually test condition for standard EMC-tests. Typical test equipment like power supply, filters and coupling/decoupling networks are designed for 230 V or 400 Vac. Correspondingly a specific preparation for the test task was necessary.

For an appropriate monitoring of all functional conditions explained in section 1 all tests were performed on a sample from mass production as well as on a special modified test sample. The modified samples got an optical interface from the manufacturer with direct access to the internal control circuit. With an additional optical monitoring device it was possible to trigger the spark-gap and the bypass-circuit without any disturbances caused by the EMC-test.

Generally the EMC-assessment has to consider the protective aims of the EMC-directive. There are the two parts - “Emission” and “Immunity”.

3.1. Emission

Surge Protective Devices (SPD) without electronic components or with electronic circuits with a maximum operation frequency less than 9 kHz are only able to generate electromagnetic disturbances while the arrester and limiter are working. A typical duration of such an event is in the range of micro- or milliseconds. Therefore such kind of disturbances is part of the normal electromagnetic environmental condition of low-voltage installations or apertures. For these reasons the EMC emission requirements are regarded as fulfilled according to EN 61000-6-4 (Emission).

The same situation is valid for EN 61643-11 and corresponds with the statement of EN 61000-6-4. Due to these properties all emission requirements for DEHNlimit PV are fulfilled.

3.2. Immunity

The investigations of immunity relevant parameters are performed according to an exact test plan with all necessary test steps. All test steps are based on EMC basic standards of series EN 61000-4-x. Criteria to examine the behaviour of the EUT are based on definitions of operation parameters and operation modes:

- no unintentional trigger of the arrester
- aimed trigger of the arrester und reliable control of the bypass circuit

All performed partial tests are explained in the following sections.

3.2.1. Immunity against high-frequency fields

The immunity test against high-frequency fields are performed inside an absorber-lined chamber at a measurement distance of 3 meters. Electrical field strength levels of 10 V/m, 3 V/m and 1 V/m there applied in a frequency range of 80 MHz - 1 GHz / 1,4 GHz - 2 GHz and 2 GHz - 2,7 GHz.

A closed loop RF-power measurement system was used to control and regulate the field strength. Main task of this test is to check RF-coupling effects into the wiring system or the module components. RF-coupling can cause performance degradation of electronic components or changes of working conditions.

Figure 3 shows the test setup inside the absorber-lined chamber with the EUT on top of the test table.

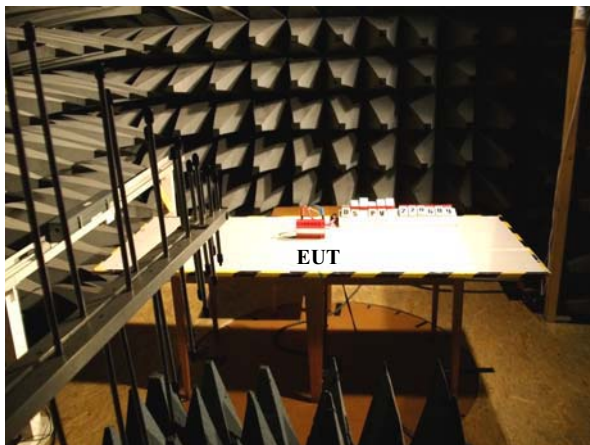

Figure 3 – Test Setup for immunity tests against high-frequency fields

3.2.2. Immunity against conducted RF

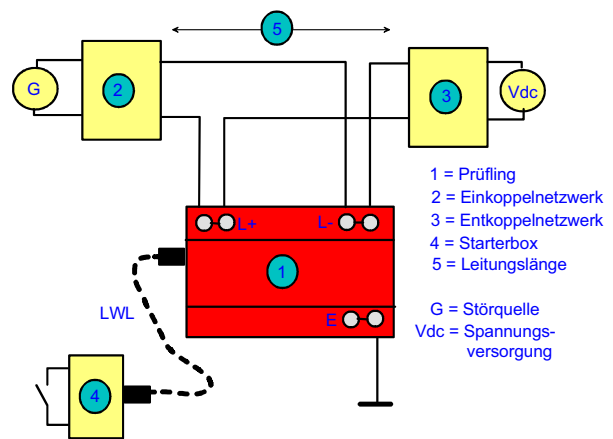

Figure 4 – Basic test setup for conducted RF-immunity

Coupling in the frequency range below 80 MHz is carried out mainly along of conducting lines and wires. For this reason this coupling effect is called RF-injection. The test is described in the basic standard EN 61000-4-6. Inside the frequency range of 150 kHz – 80 MHz a coupling of a RF-Voltage of 10 V is used by means of an Coupling/Decoupling Network (CDN) respectively an coupling clamp into the mains of the EUT. Figures 4 shows the basic test setup for conducted RF-immunity tests.

3.2.3. Immunity against magnetic fields

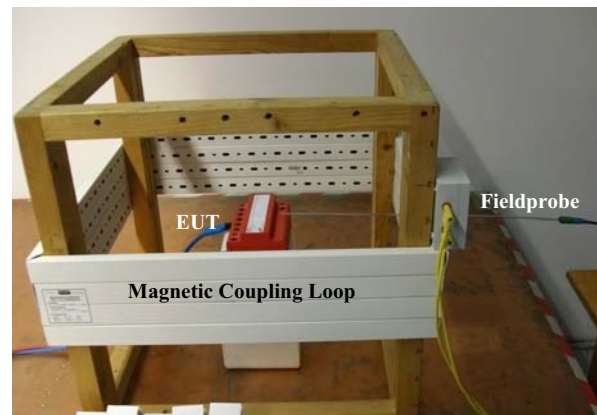

Figure 5 – Setup for immunity tests against magnetic fields

Physical basic of the immunity test against magnetic fields of energy technical frequencies are possible effects of such magnetic fields inside the operation environmental of PV-installations an parts of such systems. By using a remotely controlled current source and a special designed H-Field loop antenna a homogeneous Field of 300 A/m there generated. The Field was calibrated with a magnetic field probe based on a Hall-sensor element. The value of the

generated field strength is higher as the requirements inside the basic standard EN 61000-4-8 but was selected in coordination with the test lab and the manufacturer. Figure 5 shows the EUT inside the magnetic coupling loop.

3.2.4. Immunity against SURGE pulses, against fast transients (BURST) and electrostatic Discharge (ESD)

The EUT is designed to protect other electrical devices from transient overvoltage. Therefore the normal electrical operation condition is characterized as a critical electromagnetic environmental with high transient disturbances and EMC-tests with transient test levels (SURGE, BURST, ESD) are very important. Major task of these tests with typical EMC test levels is to check that under this EMC conditions there is no unintentional trigger of the arrester and the bypass circuit.

Figure 6 shows the reaction of the test sample to a Voltage pulse with a maximum value of 1,0 kV additional to the normal operation DC-voltage of 1000 V between the active conductors L+ und L- . Protection elements are limited and the original voltage pulse with a shape of $T_1/T_2 = 1,2/50 \mu s$ is limited and reshaped but a complete ignition was not detected.

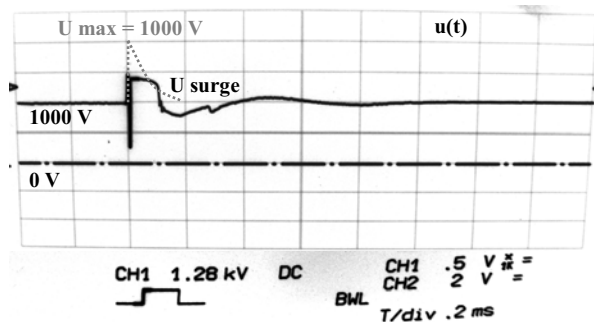

Figure 6 – Measurement results of immunity tests against surge voltages

BURST pulse trains are applied by using capacitive coupling networks and coupling capacitors directly into the mains wires. Also here there was no unintentional trigger of the arrester and the bypass circuit to detect. The electronic control circuit was uninfluenced by the very fast (5/50 ns) and repetition BURST pulses.



Figure 7 – Test Setup for ESD-tests

Usually ESD-Tests are performed only on such test points or surfaces of EUT's there under normal operation condition are users can touch the points or surfaces. In respect to maintenance and service processes during installation and operation all surfaces of the EUT are selected for testing. Figure 7 shows the test setup with EUT on the horizontal coupling plate and the ESD-Generator.

3.2.5. AC-Components on the DC-Mains

Due to the operation conditions of the protective devices in DC-circuits of PV-generators with connections to DC/AC converters care should be taken to test the effect of remaining AC components on DC mains of the test samples. Tests are performed according to the basic standards EN 61000-4-16 and 17 with special procedures from MIL-STD-461E. Figures 8 show the block diagram of the test setup with a signal generator and power amplifier to generate residual AC-Components and a coupling transformer to add the AC-disturbances to the DC-Mains. The Test were performed at discrete frequencies:

- from 50 Hz – 1,5 kHz (7 Steps) with a test level of 10 % of U_{dc} and
- from 2 kHz – 40 kHz (6 Steps) with a test level of 5 % of U_{dc}

Figure 9 shows the measurement results at a test circuit with an overlay of 100 V / 1 kHz during the calibration process.

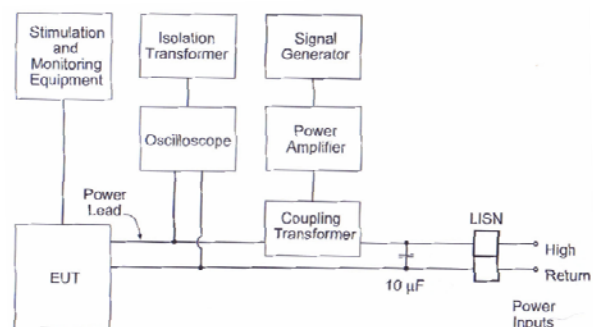

Figure 8 – Block diagram of the test setup with AC-components on DC-Mains

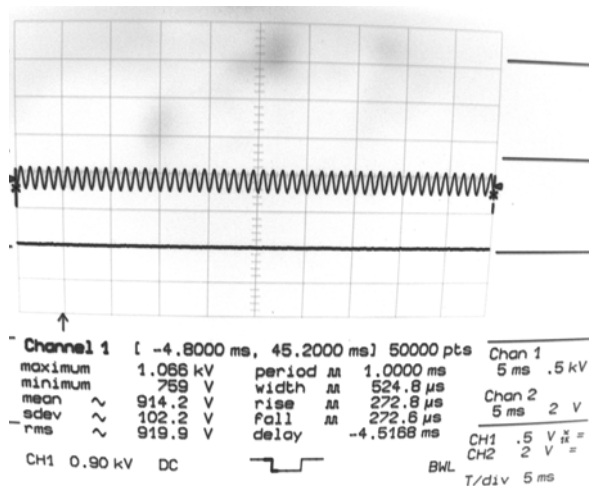

Figure 9 – 100 V / 1 kHz overlay to DC-Mains

4. RESULTS AND SUMMERY

All explained and performed partial tests for the assessment of immunity related properties of the surge protective device DEHNlimit PV are successfully passed. There was no disturbance, performance degradation or destruction of any electronic part ascertainable.

With this result is shown that the EUT with internal electronic control circuit fullfills all safety and electromagnetic compatibility requirements according to the product standard EN 61643-11 and basic requirements such as generic EMC-standard for industrial applications.

The paper presents a method for the selection of EMC requirements for products there dedicated product- or product family standard are not available currently.

This method could be used for the EMC assessment of new electrical devices with internal electronic components or circuits in future. Also for other device classes such as low-voltage switch gears there is a trend to integrate new function by using electronic parts. As a result the EMC test will get a large part during the product certification.

5. REFERENCES

- [1] www.dehn.de
- [2] J. Schönau, M. Naß: „Sicherheitsanforderungen an Photovoltaik-Module“, 54. Internationales Wissenschaftliches Kolloquium, Technische Universität Ilmenau, September 2009, Tagungsunterlagen
- [3] J. Ehrler, B. Schulz: „Besonderheiten bei der Auslegung von Überspannungsschutzgeräten für Photovoltaik-Anlagen“, 7. VDE/ABB-Blitzschutztagung, November 2007, Neu Ulm, Tagungsband S. 167-171
- [4] Richtlinie 2006/95/EG des Europäischen Parlaments und des Rates vom 12. Dezember 2006 zur Angleichung der Rechtsvorschriften der Mitgliedstaaten betreffend elektrische Betriebsmittel zur Verwendung innerhalb bestimmter Spannungsgrenzen, veröffentlicht im Amtsblatt L 347/10 vom 27.12.2006
- [5] EN 61643-11:2007 „Überspannungsschutzgeräte für Niederspannung - Teil 11: Überspannungsschutzgeräte für den Einsatz in Niederspannungsanlagen - Anforderungen und Prüfungen“
- [6] Richtlinie 2004/108/EG des Europäischen Parlaments und des Rates vom 15. Dezember 2004 zur Angleichung der Rechtsvorschriften der Mitgliedstaaten über die elektromagnetische Verträglichkeit und zur Aufhebung der Richtlinie 89/336/EWG, veröffentlicht im Amtsblatt L 390/24 vom 31.12.2004
- [7] EN 61000-6-2:2005 „Elektromagnetische Verträglichkeit (EMV) - Teil 6-2: Fachgrundnormen - Störfestigkeit für Industriebereiche“
- [8] EN 61000-6-4:2007 „Elektromagnetische Verträglichkeit (EMV) - Teil 6-4: Fachgrundnormen - Störaussendung für Industriebereiche“
- [9] www.ce-lab.de