

**54. IWK**  
Internationales Wissenschaftliches Kolloquium  
International Scientific Colloquium



**Information Technology and Electrical  
Engineering - Devices and Systems, Materials  
and Technologies for the Future**



Faculty of Electrical Engineering and  
Information Technology

Startseite / Index:

<http://www.db-thueringen.de/servlets/DocumentServlet?id=14089>

## Impressum

Herausgeber: Der Rektor der Technischen Universität Ilmenau  
Univ.-Prof. Dr. rer. nat. habil. Dr. h. c. Prof. h. c.  
Peter Scharff

Redaktion: Referat Marketing  
Andrea Schneider

Fakultät für Elektrotechnik und Informationstechnik  
Univ.-Prof. Dr.-Ing. Frank Berger

Redaktionsschluss: 17. August 2009

Technische Realisierung (USB-Flash-Ausgabe):  
Institut für Medientechnik an der TU Ilmenau  
Dipl.-Ing. Christian Weigel  
Dipl.-Ing. Helge Drumm

Technische Realisierung (Online-Ausgabe):  
Universitätsbibliothek Ilmenau  
[ilmedia](#)  
Postfach 10 05 65  
98684 Ilmenau

Verlag:



Verlag ISLE, Betriebsstätte des ISLE e.V.  
Werner-von-Siemens-Str. 16  
98693 Ilmenau

© Technische Universität Ilmenau (Thür.) 2009

Diese Publikationen und alle in ihr enthaltenen Beiträge und Abbildungen sind urheberrechtlich geschützt.

ISBN (USB-Flash-Ausgabe): 978-3-938843-45-1  
ISBN (Druckausgabe der Kurzfassungen): 978-3-938843-44-4

Startseite / Index:

<http://www.db-thueringen.de/servlets/DocumentServlet?id=14089>

# EXPERIMENTAL RESEARCH OF ELECTROHYDRAULIC DRIVE FOR ARC FURNACES ELECTRODES TRANSMISSION SYSTEM

*Elizarov Konstantin*

Institute for electrical engineering, chair FEMAEK-AETUS  
Moscow Power Engineering Institute

## ABSTRACT

In the paper are considered the technology and the result of performed experimental research of arc furnaces electrodes transmission system and its electrohydraulic drive, and creation their adjusted models. There are given results of experimental measurements on the working 12 t. DC-arc furnace, and working 25 t. AC- arc furnace. Experiments goal was to acquire electrode-positioning mechanisms hydraulic drives mathematical model and electrodes ends vibrations model, to align those models parameters and to utilize them for arc furnaces power governors' controller synthesis. According to research results an invention of adaptive arc furnaces power governors was exploited.

*Index Terms* – arc furnace, control system, modeling, electrical engineering, electrode, drive, electrohydraulic, experimental research, power governor, vibration.

## 1. INTRODUCTION

Arc furnaces are widely used in processing procedures starting with fusible ferrous metals and alloys to ferroalloys production and solid state electricity-nonconductive material casting.

Arc furnaces productivity depends to a considerable degree on electrodes transmission system, which is basically electromechanical (for small capacity furnaces) or hydraulic (for big capacity furnaces). Application of hydraulic electrodes transmission system drive seems to be the most promising, because it makes possible to simplify transmission systems kinematical scheme, and considerably raise furnace processing speed.

## 2. PROBLEM STATEMENT

Usually the problem of acquisition of adequate arc furnace model is solved during furnace control system designing process [1], particularly electrodes



*Figure 1 Direct Current Arc Furnace DPS-12*

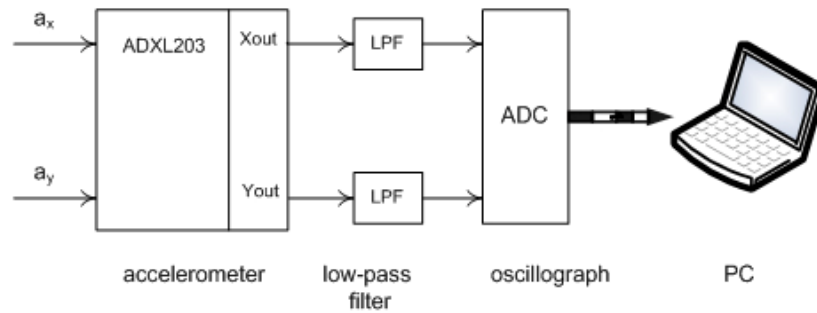

Figure 2 Acceleration measurement

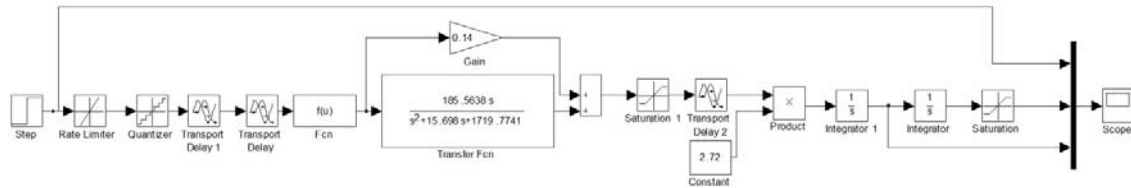

Figure 3 Hydrodrives experimental model build in Matlab Simulink

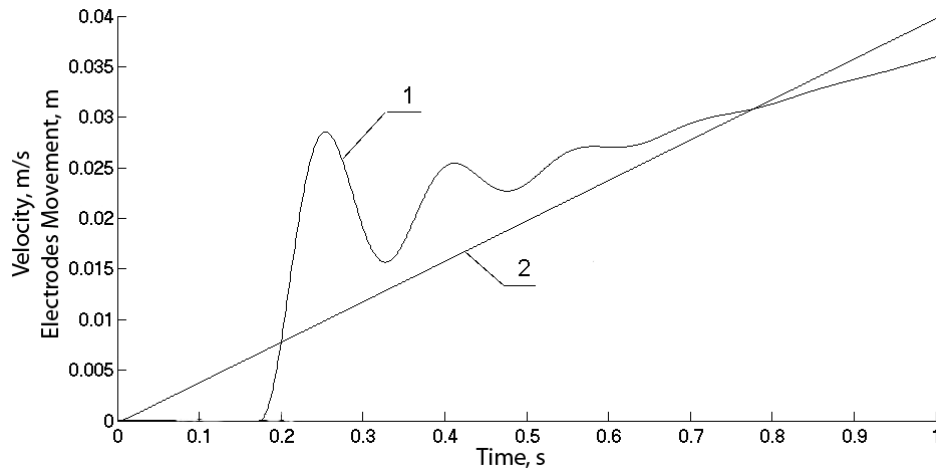

Figure 4 Modeling results

transmission systems model should be determined. Electrodes transmission system influences on efficiency, accuracy, stability of arc furnaces control system working, per se electrode transition is the singular accessible control force for automatic control system, especially in alternating current furnace. Difficulties in adjustment of control system for furnaces with hydraulic drive are conditioned by presence of elements with nonlinear characteristics. They are hydraulic actuator, supply line, hydrocylinder, and electrode holder. It is necessary to hold an experimental investigation to receive adequate model of real processes in electrodes transmission drives, and on the basis of the investigations to identify meaning and influence of each factor and element. However processes connected with electrodes ends vibration (which can reach tens centimeters [2]) can also essentially effect on regime adjustment accuracy (electrical energy specific discharge, melting duration etc.). Existence

control systems don't take into consideration similar processes.

Experiments goal was to acquire electrode-positioning mechanisms hydraulic drives mathematical model and electrodes ends vibrations model, to align those models parameters and to utilize them for arc furnaces power governors' controller synthesis.

### 3. SURVEY

Experimental research was conducted on working direct current 12 t. arc furnace DPS-12 of Saransk foundry "VKM-Steel"(see Fig.1), and on working alternating-current 25 t. arc furnace of Cheboksary foundry "Promtraktor-Promlit".

Control signals and feedback signals were measured directly on hydraulic units using an oscillograph. Electrode ends vibration was measured using integral accelerometer fixed on furnaces electrode (see Fig. 2). During experimental data processing were acquired hydraulic drives mathematical model (see Fig. 3) and

model of electrode-positioning unit [3]. These models contain essential nonlinearities in control signal playback. These nonlinearities indicate necessity of adaptive control systems usage. Some of modeling results are shown on Fig. 4, where 1- dependence of electrodes speed from time, 2 – dependence of electrodes movement from time.

According to research results an invention of adaptive arc furnaces power governors was exploited.

#### **4. REFERENCES**

- [1] V.P. Rubtsov, M.Y, Pogrebisskiy “Modelling in technics”, Moscow, 2008
- [2] A.I.Sapko, “Actuating units of arc furnaces power governors”, Moscow, 1980
- [3] K.A.Elizarov “Experimental research of electrohydraulic drive for arc furnaces electrodes transmission system”, Vestnik MEI, Moscow, 2009