

55. IWK

Internationales Wissenschaftliches Kolloquium
International Scientific Colloquium

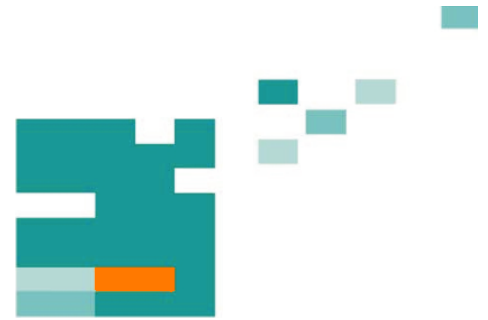

13 - 17 September 2010

Crossing Borders within the **ABC**

Automation,

Biomedical Engineering and

Computer Science



Faculty of
Computer Science and Automation

www.tu-ilmenau.de

th
TECHNISCHE UNIVERSITÄT
ILMENAU

Home / Index:

<http://www.db-thueringen.de/servlets/DocumentServlet?id=16739>

Impressum Published by

Publisher: Rector of the Ilmenau University of Technology
Univ.-Prof. Dr. rer. nat. habil. Dr. h. c. Prof. h. c. Peter Scharff

Editor: Marketing Department (Phone: +49 3677 69-2520)
Andrea Schneider (conferences@tu-ilmenau.de)

Faculty of Computer Science and Automation
(Phone: +49 3677 69-2860)
Univ.-Prof. Dr.-Ing. habil. Jens Haueisen

Editorial Deadline: 20. August 2010

Implementation: Ilmenau University of Technology
Felix Böckelmann
Philipp Schmidt

USB-Flash-Version.

Publishing House: Verlag ISLE, Betriebsstätte des ISLE e.V.
Werner-von-Siemens-Str. 16
98693 Ilmenau

Production: CDA Datenträger Albrechts GmbH, 98529 Suhl/Albrechts

Order trough: Marketing Department (+49 3677 69-2520)
Andrea Schneider (conferences@tu-ilmenau.de)

ISBN: 978-3-938843-53-6 (USB-Flash Version)

Online-Version:

Publisher: Universitätsbibliothek Ilmenau
[ilmedia](#)
Postfach 10 05 65
98684 Ilmenau

© Ilmenau University of Technology (Thür.) 2010

The content of the USB-Flash and online-documents are copyright protected by law.
Der Inhalt des USB-Flash und die Online-Dokumente sind urheberrechtlich geschützt.

Home / Index:

<http://www.db-thueringen.de/servlets/DocumentServlet?id=16739>

TOOLBOX FOR ENERGY ANALYSIS AND SIMULATION OF SELF-POWERED SENSOR NODES

Dipl.-Ing. Thomas Behrmann¹, Carolin Zschippig¹, B.Sc., Dr. Marc Lemmel¹, Dr. Stefan Bosse²

¹BIMAQ Bremen Institute for Metrology, Automation and Quality Science, University of Bremen

²DFKI Deutsches Forschungszentrum für Künstliche Intelligenz, Bremen

ABSTRACT

While the number of available high performance but low-power embedded systems rise, new application scenarios for tailored sensor systems get in reach to be implemented. In some cases battery powered or self-powered systems are needed, e.g. in the context of wireless sensor networks. Its designer has to assure, that the system is provided with the appropriate amount of energy and always enough power to fulfil its task. Often this can only be done, when the analysis is carried out in the context of the real application. Consequently a simulation has to consider the environmental condition of this context as well.

Therefore a simulation toolbox for energy and power analysis of independent sensor nodes is proposed. This presentation shows the fundamentals of a new simulation toolbox, a tool for designing modular sensor systems. The focus of this tool will be on the economic and efficient use of power and energy on the level of embedded systems.

The base of this toolbox is a growing number of simulation blocks modelling the power behaviour of embedded modules like energy sources, converters, storage and load. A set of tools for observing losses, energy throughput and power lags, assists the system designer to set up an economic solution. A strong emphasis lies on the modelling of modern energy harvesting principles and the embedding physical situation.

One main goal of this research activity is to overcome the principle of always over-sizing the power supply of electric systems for the “worst case”. Instead a situation-dependant adaptive energy management will set different operation modes of embedded systems to cope with power supply and energy situation. Therefore these systems can be specified more accurate and economic.

To save energy, the different operation modes will lead to a tailored sensor data processing. Instead of using a full micro processor, the next steps in development are configurable hardware blocks. Therefore the load models will consider different implementations on work task level.

A simple but comprehensible example will show the benefits of system analysis and should lead to a

productive discussion about future enhancements from the point of view of system designers and users.

Index Terms – Sensor node, sensorial material, energy harvesting, thermal generator, emergency management, simulink, simulation

1. INTRODUCTION

At the University of Bremen the initiative ISIS, short for **Integrated Solutions in Sensorial Structure Engineering**, is researching on the fundamentals of a new class of smart materials: sensorial materials. The aim is to join the excellence of local researchers for developing a variety of sensorial materials.

“ISIS (...) joins the University of Bremen’s competencies in integrating sensors in technical components. From design of components via development of materials and production processes, processing of information and energy supply, all relevant aspects of this topic are covered.” [1]. One goal of ISIS is to achieve advances in the technology of sensing. It identifies new areas of application for integrated sensors and develops practical implementation. The range of research activities covers classical measurement technology applied within a material as well as networks of sensor nodes integrated in a material forming a sensing organ for control, structural health monitoring or ambient cognition.

Within this research area energy harvesting principles for autonomous sensors will be investigated. Every measurement systems designer dealing with battery- or self-powered systems have to consider the energy behavior. Most classical measuring devices were designed to work on a constant and sufficient power supply. Measurement experts often are not experienced in low power design. A lot of optimizations can be applied using technology from mobile computing, control theory and artificial intelligence. Using a sensor principle not only for measuring, but also for energy harvesting, offers new perspectives. Future methods for sensorial material are varying from low power design, adapting power consumption and energy management to self-organisation, self-localisation, fault tolerance, cognition, and grid intelligence.

Therefore the measurement systems designer has to bring together several disciplines.

A typical approach is to calculate the system's power behavior and to assure the supply will never drop under the needed value of the loads. This is often done by evaluating worst case scenarios, like a dark cloudy day for solar powered devices. By adding some safety factors the measurement system will always have more than enough power available. Each system can be designed individually, but the result is often oversized for the real application.

In border cases like implanted sensor nodes in sensorial material the feasibility is often negative judged by such calculations. A better approach in these cases is to adapt the measurement task to the available power. Using energy based scheduling, adjustment of sample rate or more sophisticated adaptive calculation algorithms for leveled data processing. Simulation of energy flows have to show, that these systems will not fail in a realistic environment. These simulation results are often used to adjust the layout parameters of the system.

Experienced systems designers will state that an optimal solution depends on the special circumstances of the individual measurement task. So that for self-powered measurement nodes the system design can not be reused simply.

One step to support the activities in researching sensorial materials is to develop a new simulation toolbox for energy flows, a tool for designing modular sensor systems with an emphasis on self-powered systems.

The aim is to support the layout of energy supplying, converting, storing and consuming components. Therefore the toolbox contains generic component blocks implemented in Matlab/Simulink. They should be easily used by a measurement systems designer to layout single sensor nodes as well as sensor meshes and networks of autonomous sensor nodes.

Advanced methods and technologies like

- adaptive data processing
- energy management
- and generated specific hardware design

will be added later within the research activities of ISIS to complete the features of the toolbox.

2. SENSOR NODES

In the context of this paper sensorial abilities should be structured in a single sensor node. A sensor node could serve one or more measurements and could be supplied by single or multiple sources.

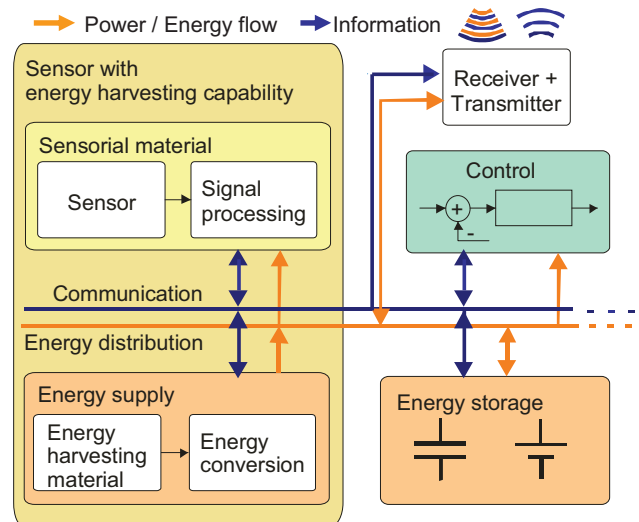

Figure 1 Example setup for a sensor node as a part of a sensorial material

Sensor nodes could be implemented according to Figure 1. The model of a sensor node can be divided into the parts data (acquisition, processing and communication) and energy (supply, storage, consume). Though the research activities also focus the optimisation of data processing and communication in respect to the energy consumption, this paper will concentrate on modelling, simulation and analysis of the energy branch.

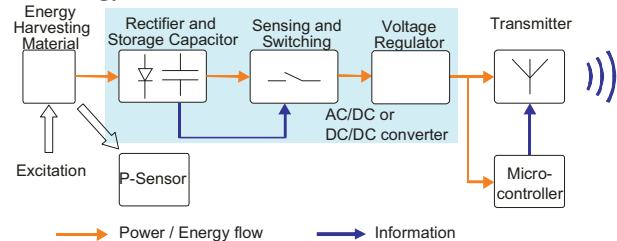

Figure 2 Example for a radio based sensor node with material for energy harvesting and sensing

For most self-powered applications the energy provided by the energy harvesting device has to get converted. In Figure 2 a more detailed view into a power system of a sensor node is displayed. Power flow from the excited harvester is converted to higher voltage levels. Typical is a small capacitor to buffer energy. When a certain voltage level is reached the next circuit activates the main functions of the sensor node. A voltage regulator is used to provide constant conditions for the parts of the node like measurement unit, processor/micro controller and if needed a radio transmitter.

3. APPLICATION SCENARIOS

Exploring the borders of sensor applications gives a fascinating outlook on future benefits.

There are many possible scenarios for self-powered sensor applications. Some are now pointed out as examples for the usage of the toolbox.

The German Federal Institute for Materials Research and Testing (Bundesanstalt für Materialforschung und -prüfung, BAM) uses wireless sensor networks for the condition health monitoring of large constructions like bridges [2]. It was considered whether solar powering offers a reliable solution at the aiming scenario and so batteries (A class) were used to be safe. For similar problems Moser proposes “Equipped with photovoltaic cells, perpetual operation becomes possible without frequent recharging and replacement of the batteries. Ideally, sensor nodes once deployed in a harsh environment benefit from a drastically increased operating time and become virtually immortal. Since batteries are solely used as energy buffers and not as primary energy sources, the cost, weight and size of batteries can be reduced significantly”[1]. This would be supported by a simulation approach to find the correct system parameters for different location and weather conditions.

In the area of robotics a common problem is, to avoid collisions harming people working in the range of e.g. a robot arm. One vision is a sensing organ on the surface of the robot construction detecting approximations or collisions with the environment. Classic design of this sensor system would incorporate a lot of cabling, power distribution and configuration efforts. Failure of a single sensor would normally affect the systems performance and could lead to an emergency stop of the robot system. Introducing redundancy would avoid this situation, but almost doubles cabling and configuration. Repairs in such a fine granulated sensor grid could lead to high maintenance costs of the system.

We propose the usage of a sensing foil with a grid of proximity sensor nodes. For energy supply and communication the foil could be equipped with two metalized coatings and use a 1-wire bus system [4]

For carbon fiber-reinforced polymer (CFRP) one difficulty has been identified using this technology in all-day-life. A damage in materials structure could happen by collision with other objects, which is not that easy detected as it is on metallic parts. It is possible that internal damage weakened the structure significantly without observable surface damage.

A vision for the usage of CFRP in high safety areas like airplanes is to have a fulltime shock monitoring of large area CFRP parts. A vibration based energy harvester could supply a sensor node implanted/build in the material. A radio based network could report a shock signature to a central structural health condition monitoring (SHM) system, that could alert the user for a closer check-up of that part before relying on that part (e.g. take-off).

In offshore wind turbine technology a pre-emptive maintenance is reducing costs and downtime. A rotation and gravity based energy harvesting source could power a monitor sensor node for full observation of stresses inside the wind turbine blade.

A fiber Bragg grating (FBG) sensor integrated in carbon fibre material could measure strain information. To avoid additional cabling, weakening the structure, a wireless data transport would be appropriate for sending health status, tendencies and alerts. This approach could lead to smaller lightweight rotor blades with a flexible maintenance point based real stress history. This point could be planned some weeks in advance for optimal time schedule of the service equipment and spare part logistics.

As many other authors point out the list of possible application scenarios is long. Some potential scenarios that could be analysed and parameterized by the usage of the toolbox have been mentioned here.

4. TOOLBOX

The structure of the toolbox is oriented on the node scheme according Figure 1 and is ordered from the energy’s point of view (Figure 3).

For each element there are generic blocks in the structure to cover the main functionality. Special parts can be derived and added to the Library.

According to the naming conventions in Matlab/Simulink an input signal is connected to an “inport” and the output of a block is fed through the “outport”. A mask in Simulink can be provided as a GUI for setting parameter values comfortably, which are then connected to constant values inside the block model implemented in Simulink. [5]

All blocks of the energy toolbox are masked for convenience e.g. to parameterize the block according to the data sheet (see Figure 5).

In the next chapters some example implementations are described to learn to know the basic structure of the toolbox and allow the reader to follow the application scenario in the next chapter easily.

4.1. Energy Sources

The energy sources class covers the various possibilities for providing energy to the sensor system. In conventional design there is a constant source providing a much power as needed. This tool enables the user to tailor the ratings for main and maximum use. For the possibility of environment dependant

- Energy Sources
 - + Batteries
 - + Ideal Sources
 - + Inductive/Magnetic
 - + Mechanical
 - + Piezo Electric
 - + Photo Electric
 - + Thermal Electric
 - + Transformers
- Energy Converters
 - + AC/DC
 - + DC/DC
 - + Voltage Regulators
 - + PWM
 - + Amplifier
- Energy Storage
 - + Accumulators
 - + Capacitors
- Energy Consumers
 - + Actuators
 - + Microcontrollers
 - + Sensors
 - + Radio Modules
 - + Illuminants

Figure 3 Structure of toolbox

energy sources the blocks have the ability to be fed by different environmental conditions, e.g. solar radiation to a photovoltaic cell.

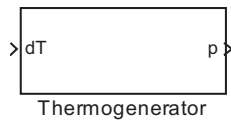

Figure 4 Thermoelectric generator block

Another scenario is a thermoelectric generator (see Figure 4) which converts heat directly into electrical energy using the Seebeck effect.

It is modelled as an ideal module, neglecting contact resistances.

The power output is calculated as:

$$P = \left(\frac{\alpha \cdot \Delta T}{R_i + R_L} \right)^2 \cdot R_L \quad [6]$$

with:

- α the Seebeck coefficient/Thermopower
- ΔT the temperature difference between the two sides
- R_i the internal resistance
- R_L the external resistance

For quick approximation there is also the option of calculating the generated energy as:

$$P = \frac{P_{ref}}{\Delta T_{ref}^2} \cdot \Delta T^2 \quad [7]$$

This can be used when there is a reference power output given at a reference temperature difference.

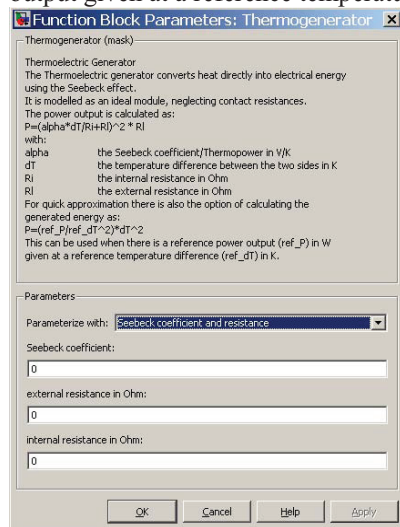

Figure 5 Block parameters thermogenerator block

4.2. Energy Converters

Electric parts for converting and regulating energy flows are a technical need. Focusing on the energy the most important fact is that these devices are not lossless and so the loss of power has to be calculated. Most modern devices like DC/DC converters etc. use switched power operation. A generic approach for calculating losses without implementing the real operation is sufficient at the level of systems definition and could be recalculated when the hardware layout is fixed.

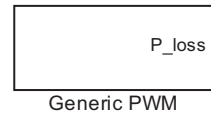

Figure 6 Generic PWM

The generic PWM (pulse width modulation) block models the power consumption due to the ohmic resistance of the switch when in “on” position and switching losses.

The power consumed is calculated as

$$P_{loss} = t_{switch} \cdot f_{pwm} \cdot U \cdot I + \overline{I}^2 \cdot R_{on} \quad [8]$$

with:

- t_{switch} time needed to switch between on and off
- f_{pwm} switching frequency
- U voltage of the power source
- I current at maximum voltage
- \overline{I} average current
- R_{on} ohmic resistance of the switch when in “on” position

The output supplies the information how much power is consumed.

4.3. Energy Storage

The generic capacitor block contains a simple model of a capacitor. The equivalent circuit is shown in Figure 7.

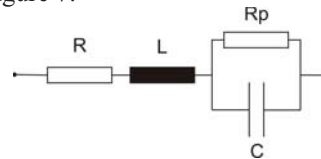

Figure 7 Equivalent circuit of a generic capacitor

The series resistance R represents effects of dielectric losses and conductor resistance. The capacitor inductance is represented by the series inductance L . The parallel resistance R_p models leakage current flow and the self-discharge.

These values have to be entered into the blocks mask. If the value of the series resistance is not known, the dissipation factor $\tan \delta$ and the according frequency can be entered instead.

Note that the time needed for self-discharge is approximately $5 \cdot R \cdot C$.

An initial voltage across the capacitor can be entered into the mask. The inport signal represents the power to be stored on the capacitor.

4.4. Energy Consumers

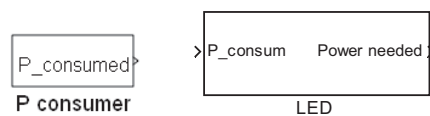

Figure 8 Consumer and LED Block

The block consumer (Figure 8) provides a generic constant power consumption. It is a good way of estimating the components by using datasheet's

values. It is useful for modelling components which not have been modelled in detail, yet.

The LED block models a generic light emitting diode. The inport signal specifies the power provided to the LED. The outport signal carries the information on how much power is needed by the LED to glow with the desired intensity.

5. EXAMPLE SCENARIO



Figure 9 Fire fighter with PDA [9]

To show the usage of the toolbox a simple scenario is chosen to elucidate the work flow of the analysis. The scenario is simplistic enough to calculate the result by hand, but it shows that someone not being an energy expert can figure out his own application scenario. After the main principles and components have been fixed it is much easier to specify

the electric circuit and the data processing on a micro controller. Therefore the measuring systems designer can concentrate on measuring and evaluation.

The proposed scenario is derived from former research activities on supporting emergency management by adding telemetric features to the equipment of fire fighters (Figure 9) [9]. It is not carried out within a real implementation.

The main idea is to provide sensing capabilities to a jacket of a fire fighter. The sensing capabilities should not rely on battery power because it should work maintenance-free.

The data is derived from a scenario described in [10] Fig. 3 and 4 (see Figure 10), were the temperature curves on the front and the backside of a protective material proposed for jacket of fire fighters “Aralite thermal liner” is plotted. It is exposed to an incident heat flux of 2.5kW/m^2 .

When a fire fighter is exposed to the heat of a fire, the inside temperature keeps cool for a while and then increases dramatically at 450 s. At this point there is a high danger on burning skin.

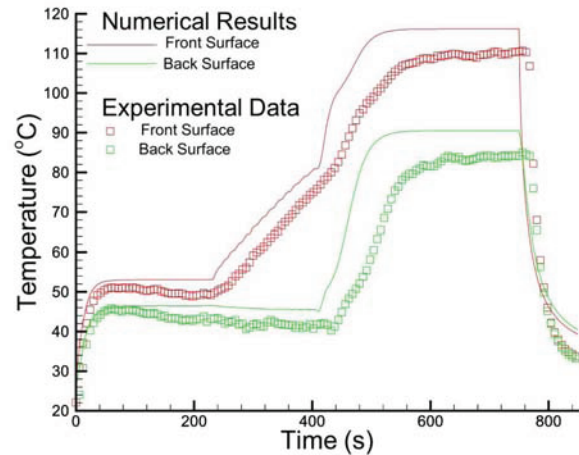

Figure 10 Temperature diagram [10] Fig. 3

If the jacket is equipped with a grid of small thermal generators the temperature gradient will start energy harvesting via the thermo generator as described in 4.1. The resulting electric power will activate and power a measuring node. The node can send out a warning to a body area controller with an alarm sound or a head mounted display or to an external operator to warn the fire man by radio to back out. A pre-warning after a minimum of temperature difference could be generated, if the rising rate of the external temperature shows alarming tendencies.

The sensor structure could be

- a) distributed sensor nodes each with an own thermal generator and temperature sensor or
- b) connected generator/sensors using conductive textiles for energy transport with a single sensor node.

For the example scenario structure b) is used.

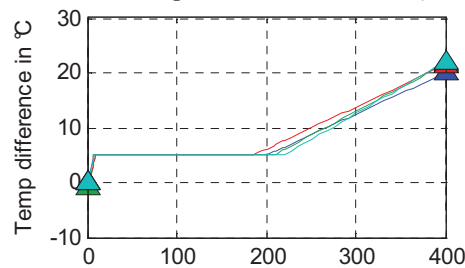

Figure 12 Boundary conditions for simulating a rise of temperature difference according to [10] Fig. 3

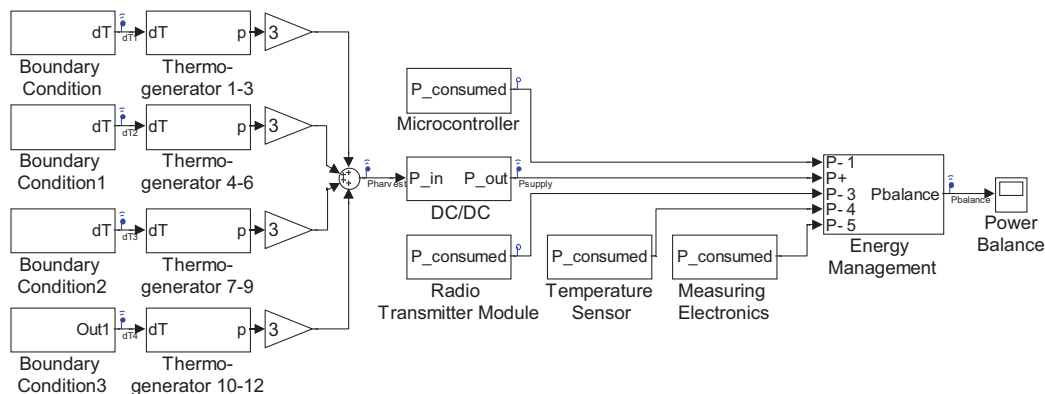

Figure 11 Power model of a thermal activated temperature alert embedded in a thermo isolating jacket for fire

According to [10] Fig. 3 the temperature difference is rising at around 200s. Being part of the jacket each thermal generator is excited a little different according to the surface temperatures at different points on the surface (Figure 12).

A sensor node configuration according to Figure 2 is used. There are 12 thermal generators sourcing a DC/DC-Converter with 30% efficiency. For the other devices the consumed power is set according the data sheet: temperature sensor ($7.5 \mu\text{W}$), measuring circuit (0.4 mW), microcontroller (0.5 mW) and radio transmitter (0.1 mW).

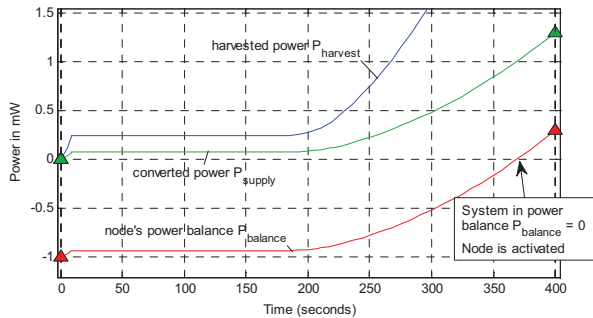

Figure 13 Power balance

The power balance in Figure 13 reaches the level of operation when generated power $P > 0 \text{ mW}$ at $t = 370 \text{ s}$. There is the Temperature difference around 20°C . This is giving 80 s of warning time till the temperature inside the jacket is rising rapidly at $t = 450 \text{ s}$ (Figure 10). Thus the fire fighter gains 80 s time while strategic withdraw is save.

Actually fire departments sometimes decide not to use these protective jackets, because of the unexpected behaviour in temperature rise. Sensor nodes like the described system are maintenance-free and can contribute to assist the fire fighters to avoid personal hazards.

6. CONCLUSIONS

The toolbox is now capable to simulate and demonstrate simple scenarios for the parameterisation of self powered sensor nodes. It is a tool for a measurement systems designer outlining new scenarios for measurement applications. Therefore the usage of the toolbox is kept simple and generic. For a full simulation of e.g. the electric circuit (Spice) or communication issues over wide spread wireless sensor networks other tools are more powerful and accurate. But these tools are limited to a defined hardware or require an exact specification. This toolbox can contribute to the process of defining them and figuring out the right hardware configuration. The focus on energy harvesting principles enables the process of exploring the area of self-powered sensors and sensorial material.

7. OUTLOOK

For the next steps the toolbox will be published fully along with tutorial and comprehensive example scenarios. At that time a portal for scientific discussion on performance and implementation of the modules will be set up and next versions could incorporate contributions of the scientific community. The aim is a powerful tool for the measurement systems designer who is an experienced all-round talent in material science, power systems, energy management, computer science and communications as well.

In the third phase the toolbox will also cover data processing, energy management and low level communications. From this basis automated generation of code for microcontroller and configurable hardware will enable rapid sensor system prototyping similar to rapid control prototyping. Then the development process is fully supported from the energy harvesting until testing in realistic conditions.

8. REFERENCES

- [1] ISIS - sensorial materials Vision and Aims. on <http://www.isis.uni-bremen.de/en/vision.html>
- [2] M. Bartholmai, E. Köppe „Funksensornetzwerk zur Strukturüberwachung und Schadensfrüherkennung an Bauwerken“ in Verteilte Messsysteme, Karlsruhe, 2010
- [3] C. Moser, Power management in energy harvesting embedded systems, Aachen: Shaker, 2009.
- [4] Dallas semiconductors “DS18S20 High-Precision 1-Wire Digital Thermometer” datasheet, 2008.
- [5] Mathworks: Simulink Reference, 2010
- [6] A. Yadav, K.P. Pipe, M. Shtein, “Fiber-based flexible thermoelectric power generator” Journal of Power Sources 175, Elsevier, 900-913, 2008.
- [7] D. Mastbergen, B. Willson, “Generating Light from Stoves using a Thermoelectric Generator”, ETHOS Conference, Seattle, Washington, 2005.
- [8] D. Graovac, M. Pürschel, “IGBT power Losses Calculation Using the Data-Sheet Parameters”, Infineon Application Note V1.1, 2009.
- [9] M.C. Lemmel, “Interactive Information and Communication System for Emergency Applications“, In: Proceedings of Emergency Telecommunications, ETSI, Sophia-Antipolis 2002
- [10] K. Prasad, W. Twilley, and J.R. Lawson, “Thermal Performance of Fire Fighters’ Protective Clothing. 1. Numerical Study of Transient Heat and Water Vapor Transfer,” NISTIR 6881, U.S. Department of Commerce, August 2002.