

# 50. Internationales Wissenschaftliches Kolloquium

September, 19-23, 2005

**Maschinenbau  
von Makro bis Nano /  
Mechanical Engineering  
from Macro to Nano**

**Proceedings**

Fakultät für Maschinenbau /  
Faculty of Mechanical Engineering

Startseite / Index:

<http://www.db-thueringen.de/servlets/DocumentServlet?id=15745>

## Impressum

- Herausgeber: Der Rektor der Technischen Universität Ilmenau  
Univ.-Prof. Dr. rer. nat. habil. Peter Scharff
- Redaktion: Referat Marketing und Studentische Angelegenheiten  
Andrea Schneider
- Fakultät für Maschinenbau  
Univ.-Prof. Dr.-Ing. habil. Peter Kurtz,  
Univ.-Prof. Dipl.-Ing. Dr. med. (habil.) Hartmut Witte,  
Univ.-Prof. Dr.-Ing. habil. Gerhard Linß,  
Dr.-Ing. Beate Schlütter, Dipl.-Biol. Danja Voges,  
Dipl.-Ing. Jörg Mämpel, Dipl.-Ing. Susanne Töpfer,  
Dipl.-Ing. Silke Stauche
- Redaktionsschluss: 31. August 2005  
(CD-Rom-Ausgabe)
- Technische Realisierung: Institut für Medientechnik an der TU Ilmenau  
(CD-Rom-Ausgabe) Dipl.-Ing. Christian Weigel  
Dipl.-Ing. Helge Drumm  
Dipl.-Ing. Marco Albrecht
- Technische Realisierung: Universitätsbibliothek Ilmenau  
(Online-Ausgabe) [ilmedia](#)  
Postfach 10 05 65  
98684 Ilmenau
- Verlag:  Verlag ISLE, Betriebsstätte des ISLE e.V.  
Werner-von-Siemens-Str. 16  
98693 Ilmenau

© Technische Universität Ilmenau (Thür.) 2005

Diese Publikationen und alle in ihr enthaltenen Beiträge und Abbildungen sind urheberrechtlich geschützt.

ISBN (Druckausgabe): 3-932633-98-9 (978-3-932633-98-0)  
ISBN (CD-Rom-Ausgabe): 3-932633-99-7 (978-3-932633-99-7)

Startseite / Index:

<http://www.db-thueringen.de/servlets/DocumentServlet?id=15745>

Yuan-Chuan Hsu, Tung-Sheng Yang, Jia-Wei Cai, Zheng-Hao Chen

## **An Influence Analysis of Compression Stability for High-Aspect-Ratio Micro-Hollow Billets in Upsetting**

### **ABSTRACT**

Metal micro-forming technique is one of the important developing tendencies in industry. The analysis of compression stability in micro-billets upsetting is also a critical issue within the research domain of forming parameters and size effect. In the current study, the 3D finite element simulation was employed to analyze the influence of upsetting velocity on the compression stability in micro-hollow billets with high aspect ratio. The study results indicated that the compression stability was found comparatively low when lower velocity was used in the upsetting of micro-hollow billets, and it was enhanced with the raise in forming velocity. However, the compression stability would tend to be an approximate value in certain higher speeds of forming velocity. In addition, the compression stability was especially satisfactory for square hollow billets in the micro upsetting. Namely, the high aspect ratio micro-billet with larger sectional shape factors would lead to higher compression stability.

### **INTRODUCTION**

The global trend of 3C and IT products is becoming multi-functional, thinner and smaller, and the devices/ components of the products also becoming miniature. The micro metal forming has the advantages of mass production, high yield ratio, low-cost and good quality controlled, which can meet the most of requirements for micro parts. It should be noted that it is not possible to apply the know-how of conventional forming processes to the field of micro metal forming, because of the so-called size-effect. Therefore, the research domains of micro metal forming are almost focused on the forming parameters and size effects. Joo [1] has developed the micro punching system to carry out the micro hole punching of the brass plate with 100  $\mu\text{m}$  thickness. Yashida et al. [2] employed the finite element method to analyze the multistage forging for watch parts. Saotome and Iwazaki [3] further conducted a study of superplastic extrusion for 10 micrometers microgear shafts.

Upsetting is one of the main deformation models in forging, and also the basic operation procedure in open-die forging. Therefore, understanding, predicting and controlling upsetting deformation are very important in practical forging production. Researchers have made efforts focusing their studies on upsetting. For example, Kulkarni and Kalpakjian [4] have conducted test to study the free deformation barreling in upsetting. Ettouney and Stelson [5-6] further presented an approximate model to calculate fold-over and equatorial-axial strains of a cylinder from workpiece geometry during non-uniform compression. Hou et al. [7] dealt with the problem of bulging and folding over in plane-strain upset forging. Lin [8] analyzed and predicted the deformation barreling in the upsetting using hollow dies. As far as compression stability is concerned, Gunasekera et al. [9] have employed the finite element and physical simulation to analyze the buckling behaviors of aluminum in upsetting.

Although much effort has been made regarding upsetting on general scale billets, little has

been focused on the study of the micro-billet upsetting, especially on the problems of compression stability of micro upsetting. So, in the current study, the finite element simulation was employed to analyze the influence of upsetting velocity on the compression stability in micro-hollow billets with high aspect ratio.

### FINITE ELEMENT SIMULATION

The finite element method, used for modeling the metal flow deformation, has become the most utilized analysis tool in die industry now. In this paper, the commercial finite-element program DEFORM-3D was employed for the analysis of micro-upsetting process. The configuration of billets and dies used in micro-upsetting is illustrated in Fig. 1. When the FE model was constructed, the punch and die was set as a rigid body, the billet as a plastic body being meshed into 6000 4-node tetrahedral elements. During simulation, the punch was compressed downward for 10mm, and the bottom die stayed in fixed position. The constant shear frictional factor was 0.01 at the billet/die interface. The forming process parameters used in the FEM on micro-upsetting and the micro-billets characters are summarized respectively in Table 1 and Table 2.

The compression stability in this study is represented by the buckling ( $\delta$ ) formed by offset or bulging in the wall of micro-hollow workpiece during upsetting. It is shown in the following equation,

$$\delta = C' - C \tag{1}$$

where  $C = (A + B) / 2$ ,  $C' = (A' + B') / 2$  (as shown in Figure 2).

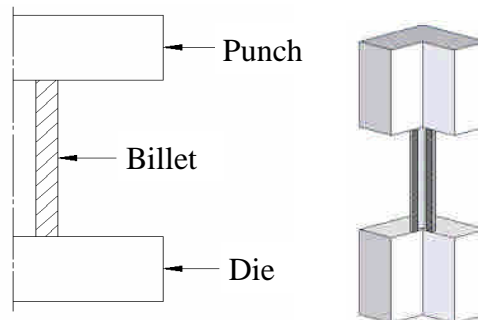

Fig. 1 Configuration of the billets and dies used in micro-upsetting (half right view)

Die	Speed	1、2、4mm/s
	Strokes	10mm
Billets	Material	AISI-1015
	Mesh number	6000
Billet / die interface	Constant shear friction coefficient	0.01

Table 1 Process simulation parameters of upsetting

	Billet section	Section diagram of billets	Sizes of billets	Shape factors
1	Round-hollow		6 mm outside diameter 3 mm inside diameter 24 mm height	0.750

2	Square-hollow		Inside diameter is 3 mm 24 mm height Section area as same as round-hollow billet	0.846
3	Hexagon-hollow		Inside diameter is 3 mm 24 mm height Section area as same as round-hollow billet	0.714
Note	Shape factors equal the ratio of circumference to area of the billet section.			

Table 2 Micro-hollow upsetting billets with different outside sectional shapes



(A) Before upsetting (B) After upsetting

Fig.2 Schematic diagram of the buckling in micro-billets upsetting

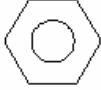
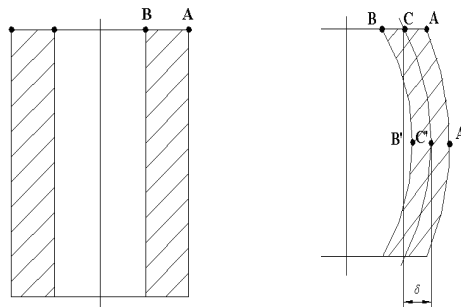
## RESULTS AND DISCUSSION

### 1 · The Influence of Forming Velocity

Figure 5 to Figure 8 show the influences of forming velocity on buckling in upsetting for hollow-square, hollow-round and hexagon-hollow micro-billets, respectively. Based on these figures, the buckling of micro-hollow billet is obviously increasing gradually following its reduced height during micro-billets upset. In micro-upsetting, the lower the forming velocity (1mm/sec) is utilized, the higher the buckling is. But, the buckling at 2 mm/sec and 4mm/sec forming velocity are quite the same. In other words, the compression stability is poor when the micro-billet upsetting is done at lower forming velocity, no matter what section shapes of billets are. At higher forming velocity, the compression stability is higher, though not increasing gradually. Therefore, there should be an optimized forming velocity which can lead to the best compression stability.

### 2 · The Influence of Sectional Shape

The upsetting deformation histories of the micro-billets with different sectional shapes at 1 mm/sec forming velocity are shown in Figure 7. As shown in the figure, the influence of the original sectional shape of billets on the buckling of upsetting workpiece is significant.

Figure 8 to 10 show respectively the influence of billet sectional shapes on the maximum buckling in upsetting processes at different forming velocity. The buckling of hexagon-hollow upsetting workpiece is higher when lower punch velocity (1mm/sec) is employed. On the contrary, the buckling of square-hollow and round-hollow are smaller and the differences of these two sectional shapes are not significant. Furthermore, when the punch velocity is at 2mm/sec, the buckling of square-hollow billet is the smallest, but that of the round-hollow is the largest. When the punch velocity is at 4mm/sec, the buckling of square-hollow billet is the

smallest, while those of the hexagon-hollow and round-hollow are higher. From these descriptions, it is obvious that the square-hollow billet holds higher compression stability during upsetting at any forming velocity. Namely, as shown in Figure 11, the larger the sectional shape factors is, the higher its compression stability in micro-upsetting of hollow billets is.

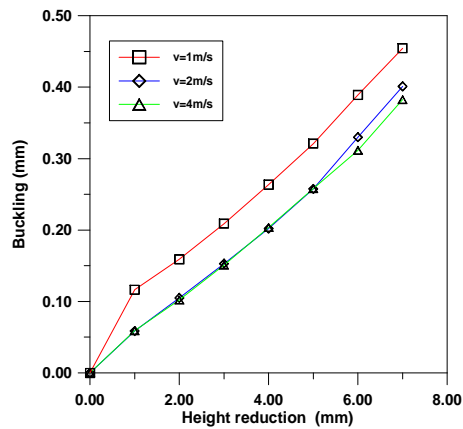

Fig.3 The relationship between forming velocity and upsetting buckling (hollow-square billet)

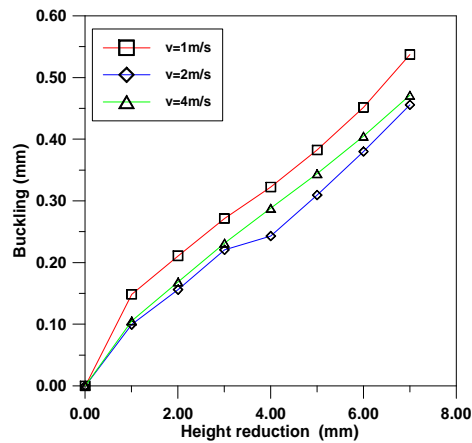

Fig.4 The relationship between forming velocity and upsetting buckling (hollow-round billet)

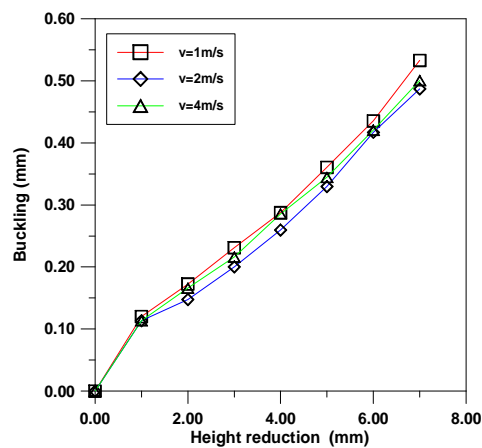

Fig.5 The relationship between forming velocity and upsetting buckling (hollow-hexagon billet)

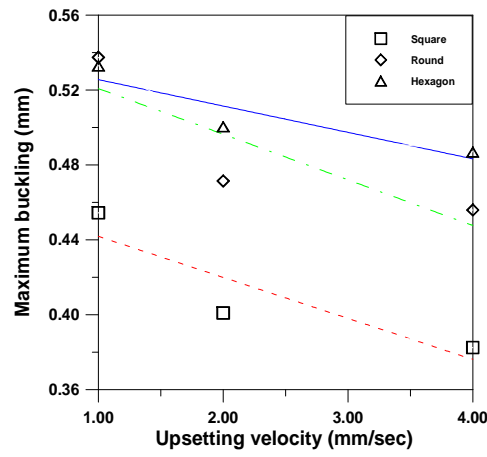

Fig.6 The influence of forming velocity on maximum buckling

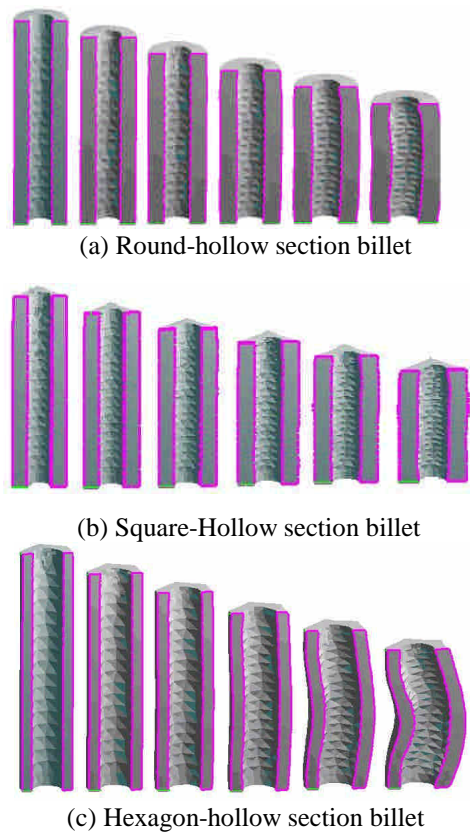

Fig. 7 The deformation histories of different section billets during upsetting

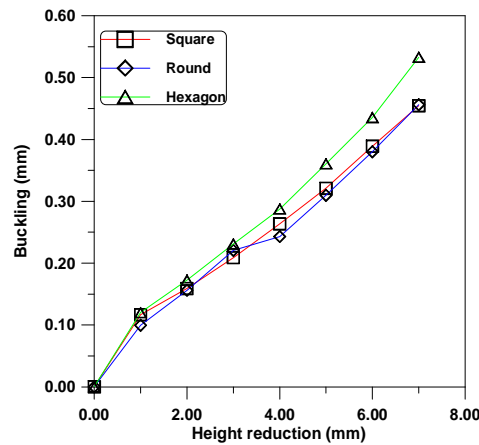

Fig.8 The influence of billets sectional shapes on upsetting buckling (at 1mm/sec punch velocity)

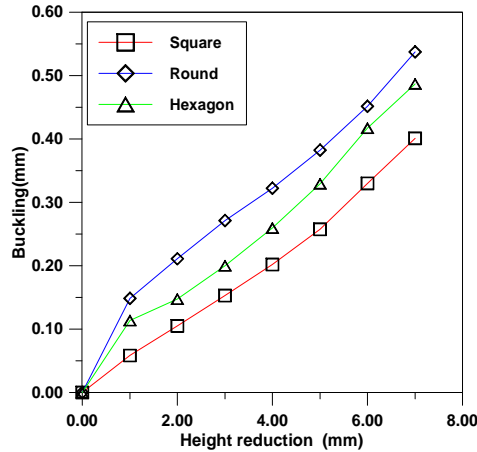

Fig.9 The influence of billets sectional shape on upsetting buckling (at 2mm/sec punch velocity)

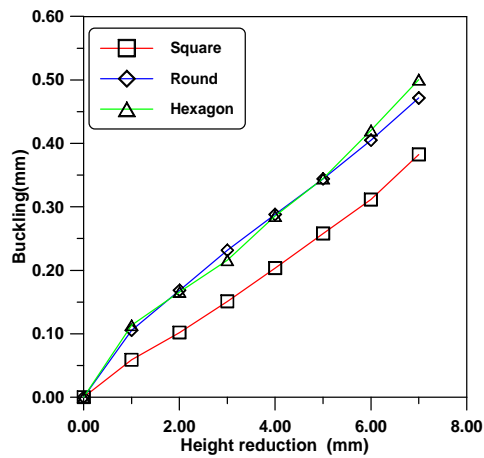

Fig.10 The influence of billets sectional shape on upsetting buckling (at 4mm/sec punch velocity)

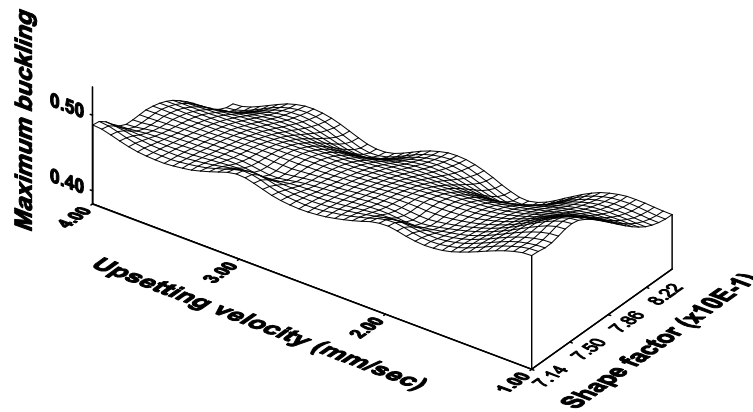

Fig.11 The relationship between the shape factor, forming velocity and maximum buckling in micro upsetting

### CONCLUSIONS

In the current study, the 3D finite element simulation was employed to analyze the influence of upsetting velocity on the compression stability in micro-hollow billets with high aspect ratio. The work has led to the following conclusions:

1. The compression stability was found comparatively low when lower velocity was used in the



- upsetting of micro-hollow billets, and it was enhanced with the raise in forming velocity.
2. The compression stability would tend to be an approximate value in certain higher speeds of forming velocity.
  3. The compression stability was especially satisfactory for square hollow billets in the micro upsetting.
  4. The high aspect ratio micro-billet with larger sectional shape factors would lead to higher compression stability.

## **ACKNOWLEDGMENT**

The authors would like to thank the National Science Council of the Republic of China for its support of this work through Grant No. NSC 93-2212-E-150-030

## **References:**

- [1] B. Y. Joo, S. I. Oh, B. H. Jeon, Development of Micro Punching, System, Annals of the CIRP, Vol. 50/1, 2001
- [2] K. Yoshida, M. Fukazawa, and I. Kubold, FEM Analysis and Experimentation Multistage Forging for Wrist Watch Parts, Advanced Technology of Plasticity, Vol. 2, Proceeding of the 6 th ICRTF, Sept.19-24, 1999
- [3] Y. Saotome and H. Iwazaki, Superplastic extrusion of microgear shaft of 10um in module, Microsystem Technologies, 6, 2000
- [4] K. M. Kulkarni, S. Kalpakjian, A study of barreling as an example of free deformation in plastic working, Transaction ASME, Journal of Engineering Industry, 1969
- [5] O. M. Ettouney, K. A. Stelson, An approximate model to calculate foldover and strains during cold upsetting of cylinders. Part I :formulation and evaluation of the foldover model, Trans. ASME 112, 1990
- [6] O. M. Ettouney, K. A. Stelson, An approximate model to calculate foldover and strains during cold upsetting of cylinders. Part II :use of the foldover model to estimate friction, Trans. ASME 112, 1990
- [7] J. Hou, U. Stahlberg and H. Keife, Bulging and folding-over in plane-strain upset forging, Journal of materials Processing Technology, 35, 1992
- [8] S. Y. Lin and F. C. LIN, Prediction of fold defect in barreling formations of cylinder upsetting, Finite Elements in Analysis and Design, 39, 2003
- [9] J. S. Gunsekera, E. J. Chitty and V. S. Kiridena, Analytical and physical modeling of the buckling behavior of high aspect ratio billets, Annals of the CIRP, 38, 1989

## **Authors:**

Yuan-Chuan Hsu, Tung-Sheng Yang, Jia-Wei Cai, Zheng-Hao Chen  
Department of Mechanical Manufacturing Engineering, National Formosa University  
64, Wen-hwa Rd., Huwei, Yunlin, Taiwan 632, R.O.C.  
Phone: 886-5-6315313  
Fax: 886-5-6310824  
E-mail: jasonych@nfu.edu.tw