

53. IWK

Internationales Wissenschaftliches Kolloquium
International Scientific Colloquium



Faculty of
Mechanical Engineering



.....
PROSPECTS IN MECHANICAL ENGINEERING

8 - 12 September 2008

www.tu-ilmenau.de

th
TECHNISCHE UNIVERSITÄT
ILMENAU

Home / Index:

<http://www.db-thueringen.de/servlets/DocumentServlet?id=17534>

Published by Impressum

Publisher
Herausgeber Der Rektor der Technischen Universität Ilmenau
Univ.-Prof. Dr. rer. nat. habil. Dr. h. c. Prof. h. c. Peter Scharff

Editor
Redaktion Referat Marketing und Studentische Angelegenheiten
Andrea Schneider

Fakultät für Maschinenbau
Univ.-Prof. Dr.-Ing. habil. Peter Kurz,
Univ.-Prof. Dr.-Ing. habil. Rainer Grünwald,
Univ.-Prof. Dr.-Ing. habil. Prof. h. c. Dr. h. c. mult. Gerd Jäger,
Dr.-Ing Beate Schlütter,
Dipl.-Ing. Silke Stauche

Editorial Deadline
Redaktionsschluss 17. August 2008

Publishing House
Verlag Verlag ISLE, Betriebsstätte des ISLE e.V.
Werner-von-Siemens-Str. 16, 98693 Ilmenau

CD-ROM-Version:

Implementation
Realisierung Technische Universität Ilmenau
Christian Weigel, Helge Drumm

Production
Herstellung CDA Datenträger Albrechts GmbH, 98529 Suhl/Albrechts

ISBN: 978-3-938843-40-6 (CD-ROM-Version)

Online-Version:

Implementation
Realisierung Universitätsbibliothek Ilmenau
[ilmedia](#)
Postfach 10 05 65
98684 Ilmenau

© Technische Universität Ilmenau (Thür.) 2008

The content of the CD-ROM and online-documents are copyright protected by law.
Der Inhalt der CD-ROM und die Online-Dokumente sind urheberrechtlich geschützt.

Home / Index:

<http://www.db-thueringen.de/servlets/DocumentServlet?id=17534>

T. Widmaier / P. Kuosmanen / T. Salmela / P. Kärhä / J. Juhanko

Improved steel strip quality by 3D ground backup rolls

ABSTRACT

Typically, backup rolls in hot strip mills are equipped with sliding bearings. It is common to use a key that prevents relative motion between the conical sleeve and the roll's shaft. The key groove causes deformation of the sleeve under load. This sleeve spring is observed as rolling force variation, which causes systematic thickness variation of the steel strip. Although there is a keyless bearing construction on the market an alternative solution was studied. A non-circular cam-like geometry that compensates the sleeve spring was ground on the backup rolls by a 3D grinding method. As a result, about 50 % of the rolling force and the thickness variations, which were synchronised with the backup rolls of the mill stand studied in this paper, were reduced.

INTRODUCTION

Background

Present day steel mills operate in a global market in which increased competition from developing countries has created a new situation. This competition has forced the existing mills to focus on producing steel of an improved and more even quality at a higher speed. The tolerances of steel strip profiles have become tighter. At the same time, the increased running speed brings out possible vibration problems in the rolling process, especially in a cold strip steel mill. If the thickness variation of the hot rolled steel strip can be reduced, it will be possible to increase the production speed of the cold strip mill. New harder steel alloys require increased milling force, thus making the rolling process more sensitive to rolling force variations. These claims set new demands on the acceptable rolling force and steel strip thickness variation levels in the milling roll stands.

The steel mills built in the 60's and 70's and even later are looking for cost-effective means to meet the new demands. This study discusses a method of improving the

quality of the end product without the need for major investments.

Research problem

The thickness variation of the rolled steel strip is mainly caused by the force variation during the rolling process. Other causes of the variations should also be visible in the rolling force measurements such as temperature differences and steel quality changes. In this study, we try to understand the phenomena behind the rolling force variations seen in the rolling force measurements and to develop methods to reduce the force and thickness variations.

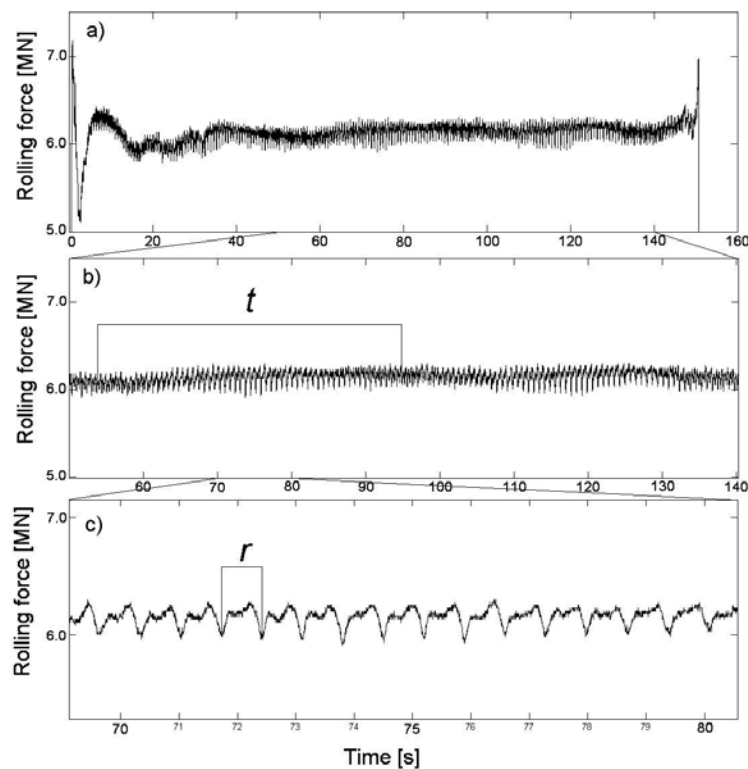

Fig. 1 Rolling force variation consists of changes of rolling force level (a), rolling force fluctuation (b) and a drop of the rolling force once in backup roll revolution (c).

A force measurement of the rolling force during the rolling process of a steel strip of a mill stand is shown in Fig. 1a. The level of the rolling force varies during the rolling process. In the beginning the force changes are quite large. The active control system of the rolling force reduces the level changes after a short period (here after approx. 20 seconds). In addition, as mentioned before, changes of temperature or steel quality can cause variation to the rolling force level.

The other variations seen in Fig. 1b and especially in Fig. 1c can be synchronised to the rotational speeds of the back-up rolls in the mill stand. This means that they are probably caused by the eccentricity of the rolls. A closer look at the structure of the studied mill stand can give an answer to the observed phenomenon. Typically a rolling mill consists of 1-7 rolling stands. There are usually two, three or more rolls in each stand. In the studied hot strip steel mill, all six stands consist of two working rolls and two backup rolls. The working rolls, through which the strip passes, are relatively small in diameter and have backup rolls of a larger diameter above and below to reduce the mill spring. A mill stand with two backup rolls is shown in Fig. 2.

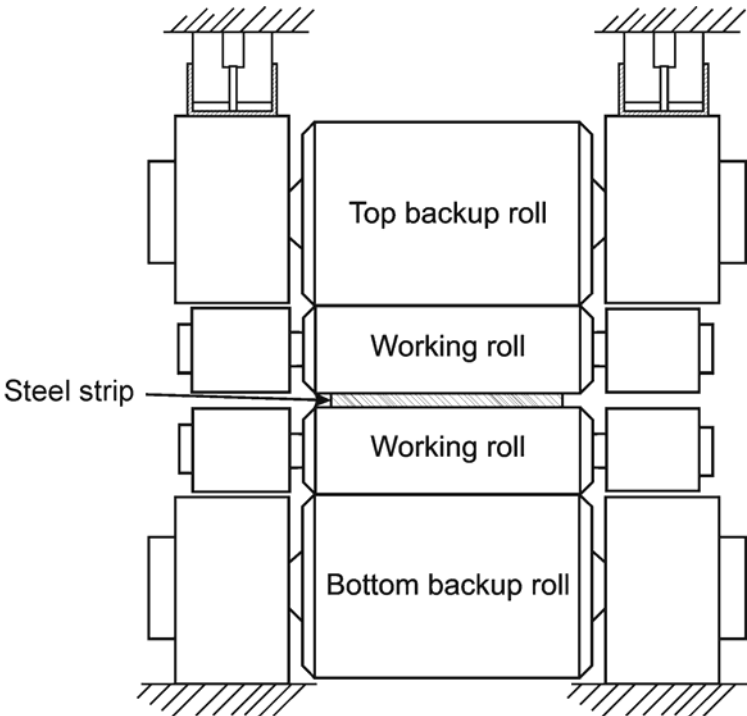

Fig. 2 A rolling mill stand unit design.

In the mill stand under study, the backup rolls have a key-type sliding bearing construction, as seen in Fig. 3. It is known that a key-type sliding bearing construction of backup rolls causes a periodic rapid drop in the rolling force [1]. The key groove is always made with a clearance in the radial direction. The clearance guarantees that there is no radial force from the key that would deform the sleeve geometry. The key-groove clearance is the main cause of the rapid force drop observed once per roll revolution (referred to as *r* in Fig. 1c). This phenomenon can clearly be seen in the same figure of the rolling force measurement.

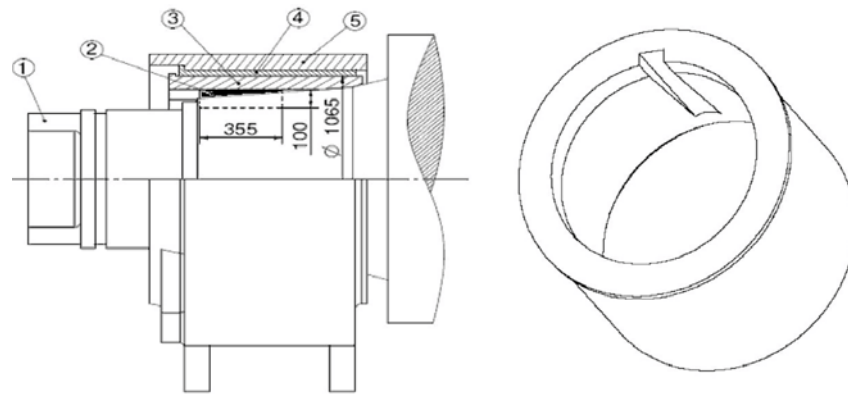

Fig. 3 Left: key-type bearing assembly with roll (1), key (2), conical sleeve (3), bearing bushing (4) and bearing housing (5). Right: conical sleeve with key groove. [3]

The fluctuation of the rolling force (referred to as t in Fig. 1b) is caused by the slow change of the relative key-groove positions in the bottom and top backup rolls (Fig. 4). The change of the positions is caused by different rolling speeds of the rolls. The rolling speeds are relative to the diameters of the rolls comparable with different sized gearwheels in a gearbox. In the case of this mill stand, the diameters of the working rolls have no effect on the rotational speed of the backup rolls, because the surface speed of the rolls is dependant only on the speed of the strip. Thus the frequency of the fluctuation can be calculated from the relation of the diameters of the backup rolls and the rolling speed. Both the rapid drop of the rolling force and the rolling force fluctuation cause thickness variation to the steel strip.

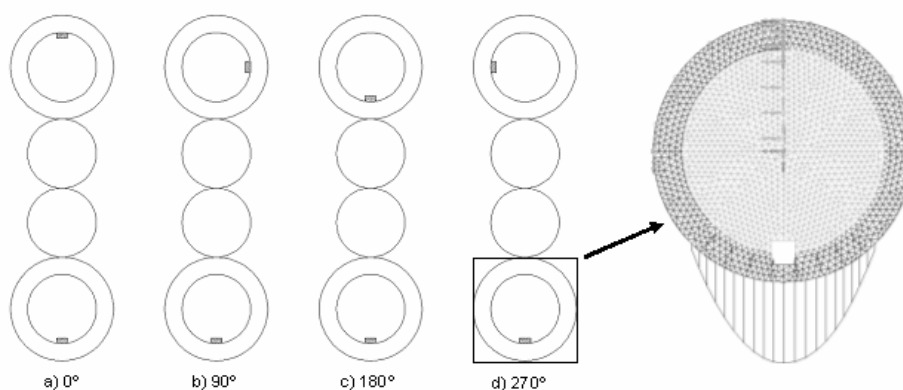

Fig. 4 Rolling force fluctuation depends on relative positions of key grooves. Estimated 2D load distribution of the backup roll's bearing assembly is shown on the right side. [3]

A keyless bearing construction reduces the run-out of rolls as compared with a key-type arrangement. Since the majority of the world's steel works built in the 60's and 70's continue to use a key-type construction, solving the problem would have a major

economic significance. Key-type bearings are also still used in new cost-effective mill stands. Different systems utilizing active control of hydraulic cylinders to compensate for the roll eccentricity have been introduced by, for example, Ginzburg [1] and Kugi et al. [2]. There are numerous methods to try to compensate the thickness variation of the steel strip and an objective therein is to use a real-time rolling line control for reducing the thickness variation of the strip resulting from a run-out of the rolls. The methods can be divided in three groups.

1. A fundamental principle in passive run-out correction methods is to render the clearance adjustment insensitive to disturbances resulting from a run-out of the rolls, such that the clearance control need not be performed as a function of the rotational angle of a roll. These run-out correction methods have not been designed in view of reducing the thickness variation of a rolled steel strip.

2. Active run-out correction methods require the detection of a run-out component in the rolls and the generation of a correction signal derived there from for a roll clearance controller. The run-out component can be worked out, among other things, from roll force, clearance gap, exit thickness of a steel strip, and from tension variation of a strip. The methods are further categorized on the basis of signal processing methods: analysing methods and synthesizing methods.

In analysing methods, the run-out component is determined from measured quantities mathematically, for example by means of Fourier analysis. In synthesizing methods, the control quantity is worked out by reproducing the roll run-out component either by mechanical or electrical means.

3. Preventive run-out correction methods have been designed to produce such rolling conditions that the thickness variation of a steel strip will be reduced without any procedures during the course of rolling.

Aim and scope of the research

The aim of this research was to reduce the periodic rolling force variation caused by the eccentricity of the backup rolls and to study how this affects the thickness variations of the steel strip. It is assumed that the magnitude of the thickness variation should

decrease together with the rolling force variation. The exact relation between the rolling force and thickness variation was not known. In this work the special case of the eccentricity caused by the sleeve spring of a key-type bearing has been studied.

The empirical research took place at a hot strip mill. The 3D grinding was applied to the backup rolls at the last (sixth) mill stand. The rolling force and the steel strip thickness variations caused by the key groove were examined. Non-systematic error sources, resonance vibrations and changes to the strip temperature, for example, were excluded from this study. In addition, systematic run-out errors like non-circularity of the neck or non-circularity of the bearing bushing were not examined. 3D grinding was applied to the backup rolls of the mill stand studied.

Research methods

Based on previous research, non-circular roundness profiles, 30 μm (top backup roll) and 50 μm (bottom backup roll) in height, were ground on the backup rolls in order to compensate for the rapid drop in the rolling force. [3]

Triggering sensors were installed on the backup roll chocks to indicate the key groove. The rolling force and the strip thickness were measured using both conventional and 3D ground backup rolls. Measuring data, which consisted of several strips, were divided into periods that represent one revolution of backup roll. Equivalent measuring points were combined with averaging. Finally, all the steel strips were combined again with averaging. This method is called synchronous time averaging [4]. The result graphs of thickness variations are filtered applying Fast Fourier Transform (FFT) [5]. The first sixteen terms in the Fourier domain, representing the first sixteen multiples of rotational frequency, also called harmonics, are used in the filtered result curves of this study. The method is described in the study of Mosier-Boss et al. [6].

The 3D grinding method introduced in this study is a method to grind different pre-defined geometries to cylinders, e.g. backup rolls. This method is mainly used for compensating measurable systematic geometry errors, i.e. run-out, roundness errors and diameter variation of a roll. The tool path to obtain the desired geometry can be based on measurements, on mathematical analyses or on a combination of these, as in this study.

METHODS AND MATERIALS

Measuring systems

The rolling force of the mill stand was measured from the drive and operator sides of the mill by Millmate PFV100 Pressductor, the resolution of which is 24.4 kN (12 bit AD converter, measuring range -50000 kN - +50000 kN) [7]. Several measurement cycles were averaged. The noise of the measuring device together with the averaging enhances the resolution of the measurement [8]. The resolution of the averaged force variation measurement depends on the number of measurements (N). With $N=100$, the uncertainty ($k=2$ indicating 95 % confidence level) caused by the resolution is 1.4 kN.

Strip thickness was measured 4415 mm after stand number six by an SSMC profile gauge, the resolution of which was 15.2 μm [9]. The total accuracy of the measuring system is $\pm 43 \mu\text{m}$ at the complete measuring range of 1 - 25 mm. The statistical noise given in the technical data of the measuring device is less than 0.1% ($< 24 \mu\text{m}$). The resolution of the strip thickness is also enhanced due to noise and averaging. With $N=100$, the uncertainty ($k=2$) caused by the resolution is 0.87 μm .

The data sampling rate of both systems was set to 300 Hz. Triggers on both backup rolls are used to indicate the key groove so that the measuring data from the rolling force and the thickness gauges can be synchronised with each backup roll.

Grinding system

The grinding machine (Fig. 5) in this study had been upgraded with a 3D grinding system and a four-point measuring system for large-scale rotors. The installed control and measurement systems are based on prototypes developed in the Laboratory of Machine Design at the Helsinki University of Technology. The grinding machine can grind backup rolls up to ca. 100 tons. The maximum length of these rolls can be ca. 5 m and the maximum diameter ca. 2 m. In both traditional and 3D grinding, normal operating parameters of the grinder were used.

The manufacturer of the grinding control system has announced accuracy values for the hard roll grinding. Accuracy in cross direction (CD) compensation (diameter variation) is

$\pm 2.5 \mu\text{m}$ and in machine direction (MD) compensation (roundness profile) $\pm 2 \mu\text{m}$. To achieve the above accuracy there are prerequisites for the proper grinding conditions. The most important is the stability of the environmental and coolant temperatures within $\pm 0.5^\circ\text{C}$ and the absence of direct sunlight and large temperature differences. Before grinding, the temperature of the roll and the grinding machine must be stabilised. [10]

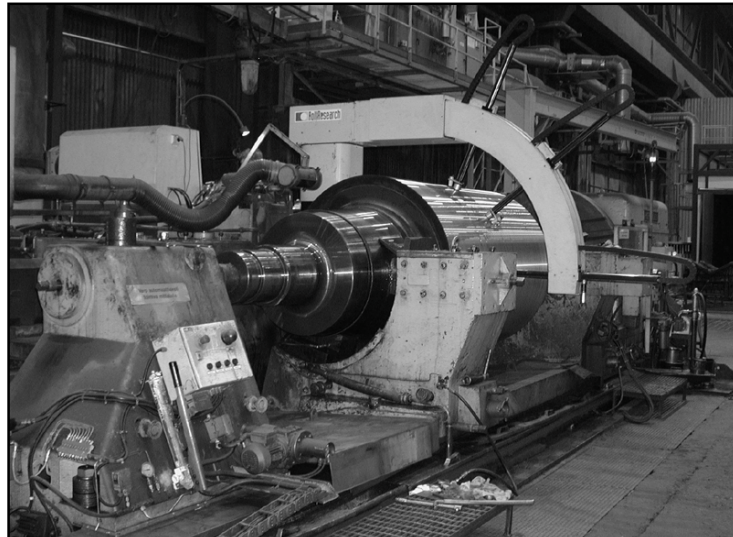

Fig. 5 The 3D grinding machine used in this study.

The grinding machine is equipped with an automated roll geometry measuring device. It is a four-point measuring system. The four-point measuring method uses four sensors in a combination of a three-point method and a two-point method. The two-point method has been used in, for example, caliper rules or measuring devices for conventional roll grinders and lathes. The three-point method can be used for roundness measurements [11]. The four-point method combines them in a more accurate way [12]. The measuring device is capable of measuring the diameter variation (CD-profile) and the roundness profile (MD-profile) of a large-scale cylinder, a backup roll, for example. The measuring accuracy is $\pm 1 \mu\text{m}$. According to the manufacturer, the optical length gauges in the device have a measuring accuracy of $\pm 0.2 \mu\text{m}$.

For data acquisition, the measurement system acquires and stores the raw measurement data in a database. The measurements can be accessed, filtered and displayed on a computer display or printer, or used for geometry error compensations while grinding.

Calculation of the sleeve spring compensation profile

The compensation profile for the 3D grinding is based on 2D and 3D finite element models of the bearing arrangement to study the shape and the order of magnitude of the spring as a function of the rotational angle of the roll. A simple model of the sliding bearing was used to determine the load distribution. A load of 10 MN was applied for each bearing. A load value of 10 MN was given from the operators of the mill as a typical load in the mill stand.

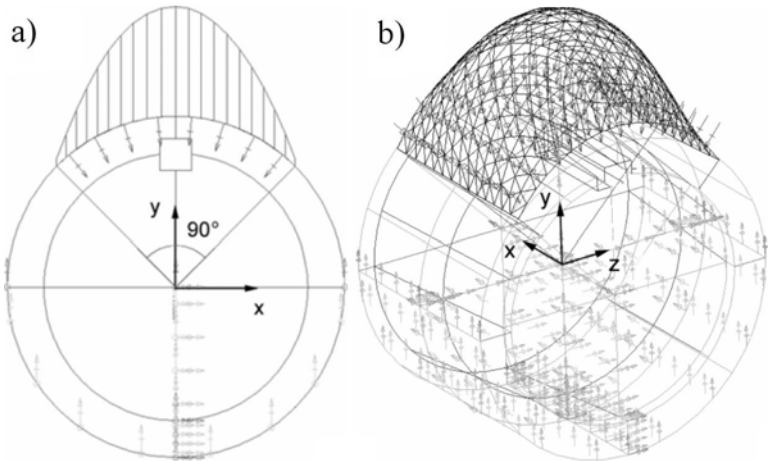

Fig. 6 Two models in the FE-analysis: 2D model (a) and 3D model (b). [3]

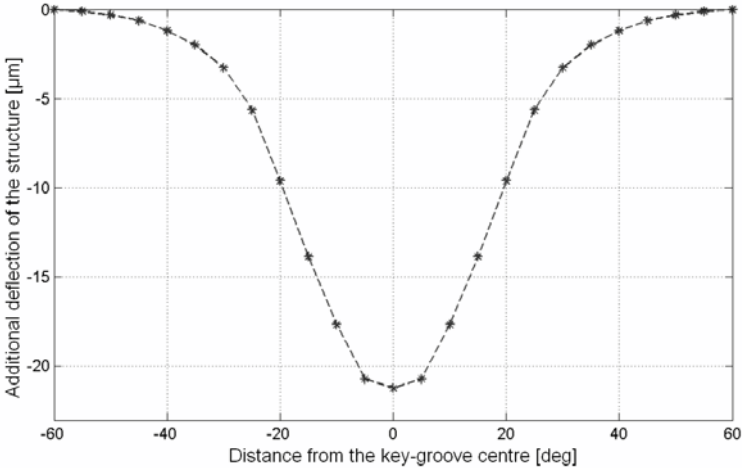

Fig. 7 Result from the plane stress linear triangle element analysis. [3]

The results from the FE-models were analyzed. The result from the model with the plane stress triangle elements was chosen as the basis of the sleeve spring compensational profile (Fig. 6a). This result was chosen because it has no points of discontinuity, and it is therefore most suitable for grinding. The result, as shown in Fig. 7, was transformed to a control curve by filtering, inverting and expanding the results to cover the whole perimeter of the roll shaft. The procedure is described by formula (1).

$$y_c(c) = \begin{cases} -y_{fe}(c) \cdot \frac{S_c}{S_{max}} & (c_c - 60^\circ \leq c \leq c_c + 60^\circ) \\ 0 & (c < c_c - 60^\circ, c > c_c + 60^\circ) \end{cases} \quad (1)$$

where:

c is the rotational angle of the roll in degrees

$y_{fe}(c)$ is the result from the FE-model (Fig. 8)

$y_c(c)$ is the correction profile (Fig. 9)

S_c is the desired scale of the curve in μm

S_{max} is the maximum of $-y_{fe}(c)$ in μm

c_c is the angular position of the key groove centre.

The final curve for the top backup roll was scaled to $30 \mu\text{m}$ (Fig. 8). The scale value was obtained from previous research [3]. In that study, the cam-like profiles machined to the bottom and the top backup rolls were of the same size. It was seen that the force drop decreased by 40 % only. Therefore, the cam size of the bottom backup roll was increased to $50 \mu\text{m}$, which was the largest size accepted by the operators of the mill stand. The calculated 3D compensation profile was used as a tool path while grinding the roll to achieve the desired cam-like geometry of the backup roll.

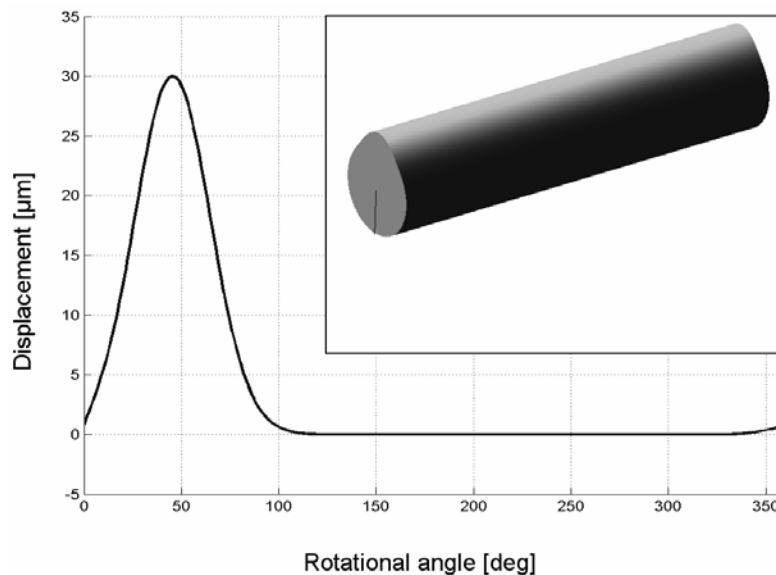

Fig. 8 The calculated $30 \mu\text{m}$ 2D correction profile for each cross section of the roll shown on the left side. The same profile was applied to the whole length of the backup roll (smaller picture). [3]

The sleeve spring compensation could be done also by modifying the bearing arrangement, e.g. by modifying the roll neck (Fig. 9a) or by modifying the bearing

bushing (Fig. 9b). In the case of this study the spring was compensated by modifying the roll surface geometry.

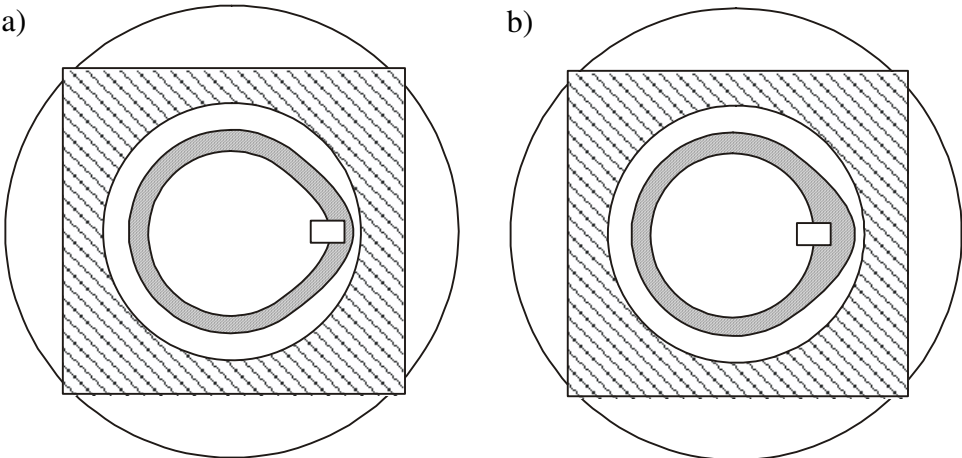

Fig. 9 Roll neck a) or bearing bushing b) modified to provide the run-out needed for the compensation for sleeve spring.

RESULTS AND DISCUSSION

Rolling force and strip thickness were measured from 2.3 mm thick steel strips. The measuring data were analyzed with synchronised time averaging, thus all the presented results represent variations, thickness or force, synchronised to the backup rolls.

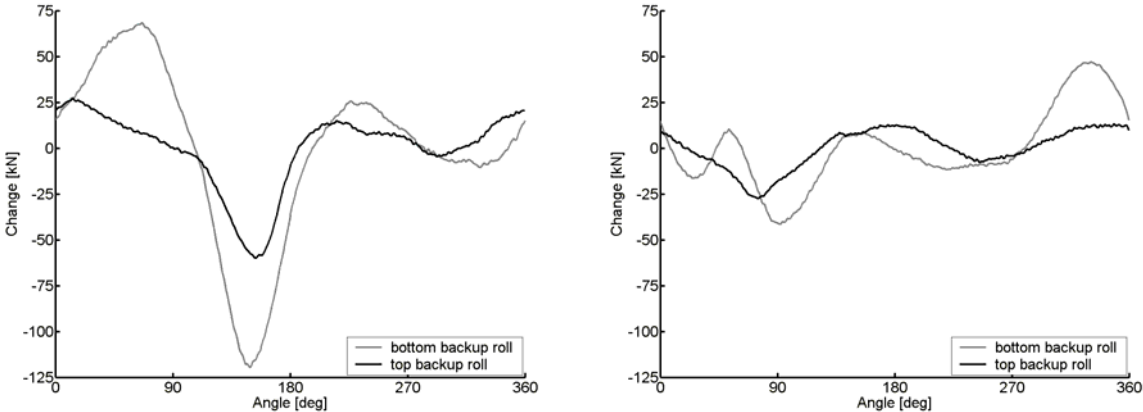

Fig. 10 Synchronised rolling force variation of 2.3 mm steel strip measured from operator side before (left) and after (right) 3D grinding.

At the beginning and end of the measurement of a strip, there are rapid level changes in the milling force (Fig. 1a), therefore, 5-10 seconds from the beginning and the end of the measuring data were cut out because of possible interference. Results of the synchronised rolling force variation measurements from the operator side of 2.3 mm

thick strips are presented in Fig. 10. Results are presented as a change of the rolling force. The phase shift present in the results in Fig. 10 is caused by the different placement of the triggering sensors after the 3D grinding. In Table 1, the results with traditional and 3D grinding are summarized. In Table 2, the force variation is relative to the mean force level during milling.

Table 1 Synchronised rolling force variation results

Side	Backup roll position	Mean rolling force level [kN]	Force variation [kN]	Number of strips (total number of roll revolutions)
Traditional grinding, 2.3 mm strip thickness				
drive	top	6635	79.8	7 (1355)
operator	top	6342	87.0	
drive	bottom	6635	134.9	7 (1335)
operator	bottom	6342	187.9	
3D grinding, 2.3 mm strip thickness				
drive	top	6873	38.2	8 (1561)
operator	top	6446	40.6	
drive	bottom	6873	75.7	8 (1588)
operator	bottom	6446	88.6	

Table 2 Synchronised rolling force variation results with traditional and 3D grinding relative to the mean milling force.

Side	Backup roll position	Strip thickness (mm)	Force variation in %		Reduction
			traditional grinding	3D	
drive	top	2.3	1.20 %	0.56 %	53 %
operator	top	2.3	1.37 %	0.63 %	54 %
drive	bottom	2.3	2.03 %	1.10 %	46 %
operator	bottom	2.3	2.96 %	1.37 %	54 %

Table 3 Synchronised strip thickness variation results.

Backup roll position	Strip thickness [mm]	Thickness variation [μ m]	Number of strips (total number of roll revolutions)
Traditional grinding			
top	2.3	3.1	7 (1355)
bottom	2.3	3.9	7 (1335)
3D grinding			
top	2.3	1.5	8 (1588)
bottom	2.3	1.4	8 (1561)

Table 4 Relative strip thickness variation results of nominal thickness with traditional and 3D grinding with FFT low pass filtering.

Backup roll position	Strip thickness [mm]	Thickness variation in %		Reduction
		traditional grinding	3D	
top	2.3	0.14 %	0.06 %	53 %
bottom	2.3	0.17 %	0.06 %	65 %

The synchronised thickness variation results from the strip thickness measurements are shown in Fig. 11. A phase shift is also present in these results because of the different placement of the trigger sensors and different positions of the key grooves relative to the strip head. The results are filtered by FFT low pass filtering with 16 harmonics. All the thickness variation results are summarised in Table 3 and Table 4.

The study showed that this method can reduce systematic force and thickness variations caused by the key groove. The best results would probably have been obtained if the method had been extended to all the mill stands. If the force and thickness data were analyzed in the frequency domain, other systematic variations in the rolling force might have been found, some of them probably caused by the working rolls, which were excluded from this study. If other systematic variations are found in further research, then these could be compensated by this method also.

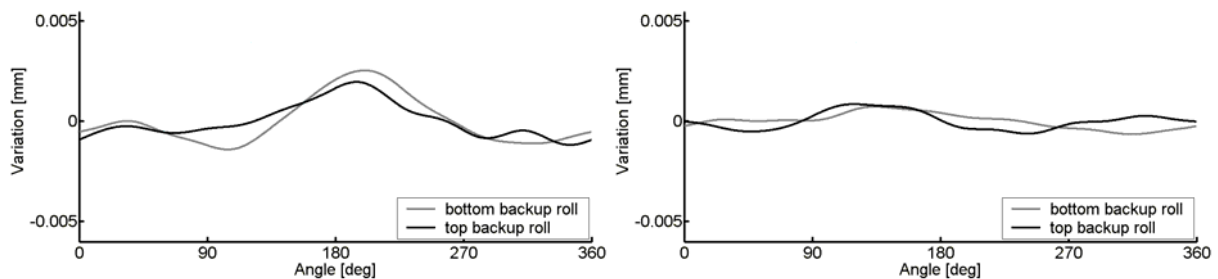

Fig. 11 Synchronised thickness variation of 2.3 mm steel strip measured before (left) and after (right) the 3D grinding.

The thickness and the quality of the end product affect the force variation of the mill stand. Thus, to achieve the best results, the backup rolls should be ground with an optimised cam profile every time the quality and the thickness of the steel changes. In most cases, this is not possible. In praxis, the cam profile could be optimised for the most common steel quality and thickness, while still not negatively affecting other qualities.

CONCLUSIONS

A common practice in setting up hot strip mill backup roll bearings is to attach the conical sleeve of the sliding bearing to the roll's shaft by a key. The key groove required by the key causes deformation of the sleeve under load. This sleeve spring is one of the causes for rolling force and steel strip thickness variations. The obvious solution is to use keyless bearings, but in this work an alternative solution was tested.

A non-circular, cam-like geometry was ground to the backup rolls to reduce the rolling force variation caused by the key groove. The effect of the reduced rolling force variation to the steel strip thickness variation was examined. The empirical research took place at

a hot strip mill. As a result, both the rolling force and the steel strip thickness variations synchronised with the backup rolls of the mill stand under study were reduced by 46-65 %. The effect of extending this method to all the mill stands of a rolling mill, as well as the usefulness of this method to reduce rolling force and strip thickness variations caused by other sources, should be further studied.

With the studied steel qualities and strip thicknesses the achieved reduction of the thickness variation has almost no effect to the processibility of the strips. With thinner steel qualities the reduction of the thickness variation is more important especially with the harder steel alloys. Steel strips with less thickness variation excite fewer vibrations with higher production speeds, thus improving the runnability and the productivity of a rolling mill stand in the further processing on a cold steel mill.

References:

- [1] V. B. Ginzburg: 'Roll Eccentricity', (ed. R. Ballas), Rolling Mill Technology Series, Vol. 1, 64, 1987, Pittsburgh, Pennsylvania, United Engineering, Inc.
- [2] A. Kugi, W. Haas, K. Schlacher, K. Aistleitner, F. M. Helge, G. W. Rigler.: IEEE Transactions on Industry Applications, 2000, 36(2), 625-632.
- [3] T. Widmaier, J. Uusimäki, P. Kuosmanen, J. Juhanko, P. Väänänen, Proc. Estonian Acad. Sci. Eng., 2007, 13(2), 168-179
- [4] P. D. McFadden, M. M. Toozhy: Mechanical Systems and Signal Processing, 2000, 14(6), 891-906
- [5] J. W. Cooley, J. W. Tukey: Mathematics of Computation, 1967, 19(4), 297-301
- [6] P. A. Mosier-Boss, S. H. Liebermann, R. Newbery: Applied Spectroscopy, 1995, 49 (5), 630-638
- [7] Millmate Roll Force Meter PFV 130, User's Guide, ABB Automation Products AB, 2000
- [8] R. Etchenique, J. Aliaga: American Journal of Physics, 2004, 72(2), 159-163
- [9] IMS User's Manual Rautaruukki Steel Finishing Mill Exit XRSSMC Profile Gauge
- [10] 10. P. Kuosmanen: 'Predictive 3D Roll Grinding Method For Reducing Paper Quality Variations In Coating Machines', No 2, 91; 2004, Espoo, Helsinki University of Technology Publications in Machine Design
- [11] S. Ozono: Proceedings of the International Conference on Precision Engineering, Japan 1974, 457-462
- [12] P. Kuosmanen, P. Väänänen: Proceedings of 5th International Conference on New Available Techniques, The World Pulp and Paper Week, Stockholm, Sweden, 1996, 1056-1063

Authors:

M.Sc. (Tech.) Thomas Widmaier*
Prof. Petri Kuosmanen*
M.Sc. (Tech.) Toni Salmela*
D.Sc. (Tech.) Petri Kärhä**
Prof. Jari Juhanko*

*Helsinki University of Technology,
Department of Engineering Design and Production,
Otakaari 4, P.O.Box 4100
FI-02015, TKK
Phone: +358 9 4512195
Fax: +358 9 451 4942
E-mail: Thomas.Widmaier@tkk.fi

**Helsinki University of Technology
Metrology Research Institute
P.O. Box 3000
FI-02015 TKK
Phone: +358 9 451 2433
Fax: +358 9 451 2222