

## IMPROVEMENT OF METROLOGICAL CHARACTERISTICS OF PORTABLE IMPEDANCE ANALYZERS

B. Stadnyk<sup>1)</sup> / T. Froehlich<sup>2)</sup> / Y. Khoma<sup>1)</sup>

<sup>1)</sup> Lviv Polytechnic National University <sup>2)</sup> Ilmenau University of Technology

### ABSTRACT

Need for portable impedance analyzers has been proven in the paper. A novel concept of improvement of the metrological characteristics for portable impedance analyzers has been developed. It's based on minimizing the analog part of the measuring channel and compensating for errors using algorithmic correction and digital signal processing. Hardware implementation of portable analyzer based on digital signal controller and modified autobalancing circuit are presented in this article. Also single-point Fourier transform in combination with Blackman-Harris window has been proven as the best solution for quadrature conversion of measuring signal over a wide frequency band. Correction algorithms have been developed in order to minimize dynamic errors, and thus to improve the systems' accuracy. Application of algorithmic correction allows to eliminate dynamic errors and extend the frequency range.

**Index Terms** – impedance spectroscopy, portable impedance analyzer, autobalancing circuit, single-point Fourier transform, windowing, algorithmic correction

### 1. INTRODUCTION

Impedance spectroscopy is a measuring technique which is widely used in various applications, such as biomedical measurements [1,2,3], materials engineering [4], particularly at the micro- and nanoscale [5], corrosion monitoring [6], control of batteries and fuel cells parameters [4,7]. In many cases studies are performed on the objects located in non-laboratory conditions. A good example is control of corrosion-resistant coatings on bridges, pipelines and other steel structures [8]. This leads to the need for a small-sized measurement devices with low power consumption called portable impedance analyzers.

Nowadays, most of the impedance measurement instrumentation are presented with stationary devices, produced by such leading manufacturers as Agilent Technologies, Wayne Kerr Electronics, Solartron Analytical [9,10,11]. These devices are multi-purpose, and can operate not only as impedance analyzers, but also as spectrum and network analyzers. However, in most cases such wide functionality is redundant, and affects in high price and big dimensions. For example, impedance analyzer Agilent 4294 has a weight of 25 kg and power consumption of 300 VA and costs more than \$ 45,000 [9].

Some companies produce small portable impedance meters, but these devices perform measurements on one or several fixed frequencies over a limited band. One of the most advanced in this class is Motech MT-4080A LCR-Multimeter (Taiwan) with acceptable weight (0.47 kg) [12]. However, the upper frequency limit of the device is 100 kHz.

Therefore, the aim of this paper is to design the structure of the portable impedance analyzer and develop a concept for improvement of its metrological characteristics by using digital signal processing and algorithmic correction.

## 2. PORTABLE IMPEDANCE ANALYZER DESIGN

The results of impedance spectroscopy are data sets, which contain values of resistance and reactance in every single point along the frequency sweep, thus it's important to achieve high dynamic performance of the device. Therefore, the use of autobalancing method (modification of I-U method) for impedance analyzer design makes lots of sense, since this approach provides relative high accuracy and speed. It also is simple in hardware implementation (in comparison to bridge or auto-compensation circuits), that means benefits in weight, costs and size [4,13]. Another fundamental requirement to portable analyzers is one-channel structure (also directly related to the size and cost).

When designing impedance analyzers, the complex issue is to ensure the stable metrological characteristics of the measurement channel across a wide frequency and measuring range. The current investigation allowed to develop a novel concept to improve the metrological characteristics of portable analyzers. This concept is based on minimizing the analog part of the impedance analyzers' measuring channel and on compensating for errors using algorithmic correction and digital signal processing [14].

According to the developed concept, using direct digital synthesis for probe and orthogonal signals generation in portable impedance analyzers makes a lot of sense. The existing types of direct digital synthesizers have various disadvantages. It makes their application as signal source in impedance spectroscopy problematic. Therefore we propose a new modified structure for direct digital synthesizers, based on a combination of binary counter and phase accumulator. We have investigated the errors and spectral composition of this modified synthesizer, and determined its required parameters.

Figure 1 shows the hardware implementation of portable analyzer. It is based on the digital signal controller STM32F4 (32-bits ARM Cortex-M4F core with Floating Point Unit). Two internal 12-bit DAC (sampling rate up to 1 MHz) and three internal ADC (sampling up to 7 MHz) enables direct processing of analog probe and measurement signals. PC communication and control is performed via built-in USB module [15].

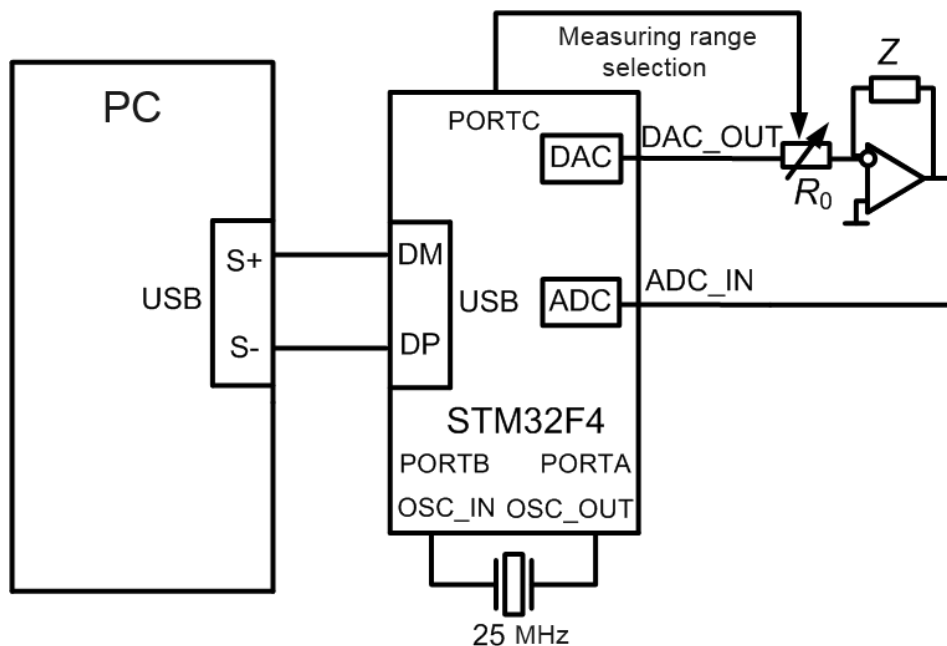

Fig. 1. Block-diagram of portable impedance analyzer

In the proposed structure, most measuring conversions (except impedance-to-voltage conversion) are implemented in digital form. In addition, the structure of the measuring channel includes no analog devices, such as filters, due to the hazard of uncontrolled phase shifts. This digitized structure of measuring channel enables to reach potentially better metrological characteristics as the errors are caused mainly by analog measuring converter. However, the impact of these errors can also be reduced by means of DSP and algorithmic correction on the stage of measuring data post-processing [14].

### 3. IMPROVEMENT OF ACCURACY OF DIGITAL BLOCKS

It is recommended to perform quadrature conversion of measuring single (procedure that returns impedance quadrature components – resistance and reactance) on the base of single-point Fourier transform (SPFT). SPFT is a special case of the discrete Fourier transform and can be described by the following equation:

$$\dot{U}_z(f) = \sum_{i=0}^{N-1} u_z(i) \cdot \left[ \cos\left(\frac{2\pi\nu}{N}i\right) - j \cdot \sin\left(\frac{2\pi\nu}{N}i\right) \right], \quad (1)$$

where  $u_z(i)$  –  $i$ -sample of the measured signal;  $N$  – number of samples used in the single-point Fourier transform (one section size);  $\nu$  – ratio of observation time to the period of the probe signal;  $U_z(f)$  – spectral intensity of the measured signal at the frequency  $f$ ;  $\cos(2\pi\nu i/N)$  and  $\sin(2\pi\nu i/N)$  – digital orthogonal signals [16].

The advantages of the SPFT algorithm are simultaneous calculation of resistance and reactance, simple software/hardware implementation and noise reduction. Also it's indifferent to all kinds of DC offsets and parasitic harmonics in measuring signal.

However, the main disadvantage of the single-point Fourier transform is its sensitivity to spectral leakage, which significantly reduces accuracy of impedance measurements. The most suitable DSP solution, which allows to overcome this issue is windowing.

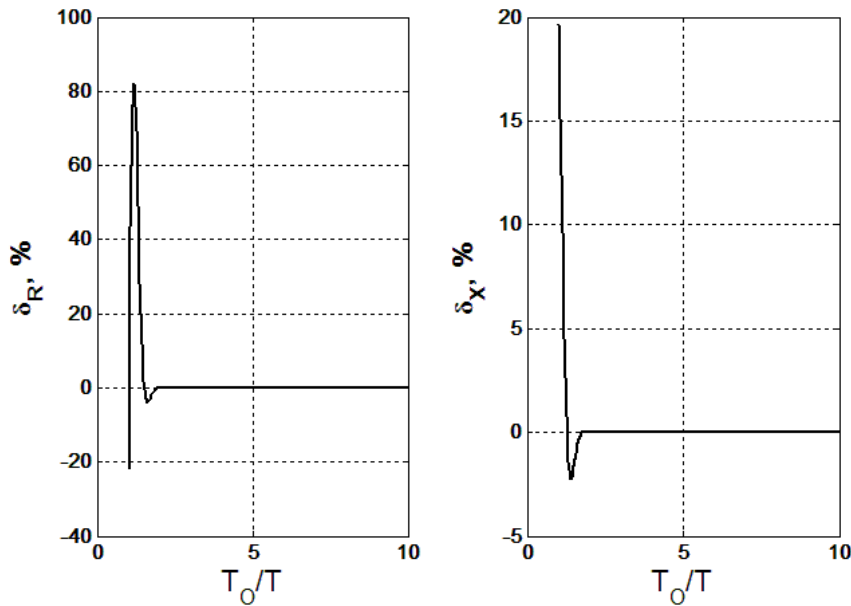

Fig. 2. Resistance (left) and reactance (right) leakage errors after application of Blackman-Harris window

The efficiency of various window functions has been investigated, but the best results were achieved for the Blackman-Harris window. In this case leakage errors become negligible (less than  $\pm 0.1\%$ ) for the signals with the period two times smaller than the observation time  $T_o/T \geq 2$  (see Fig. 2).

Thus, window functions allow to improve accuracy of impedance measurement over a wide frequency range. However, this approach requires time redundancy (increasing of the observation time).

#### 4. IMPROVEMENT OF ACCURACY OF ANALOG MEASUREMENT CONVERTER

As it was mentioned above, measuring converter remains analog and makes the biggest contribution to the total error of the impedance analyzer. The application of autobalancing circuits as measuring converters have been proven advantageous. This approach allows to reach high accuracy and resolution, good dynamic characteristics and linearity, stable current and voltage conditions on the object under test, as well as simple (one-channel) structure of measuring channel, small dimensions, low weight and low power consumption. To prevent unwanted effects (first of all self-oscillation and parasitic inductions) autobalancing circuit has been modified as shown on the figure 3 [17, 18].

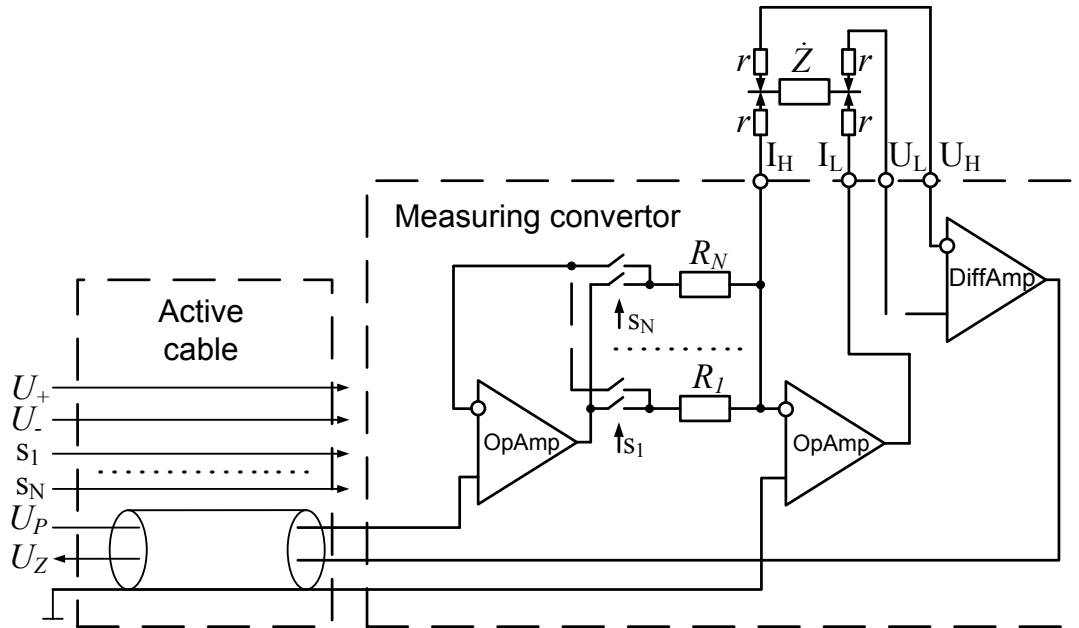

Fig. 3. Modified autobalancing circuit

The most critical impact on the system's accuracy has limited amplifiers' bandwidth (small gain on the high frequencies), what results in dynamic errors. Therefore algorithmic correction has been proposed for elimination of these errors:

$$N_R = H_R + \Delta_R = H_R - \frac{H_R(T_K + H_X) + H_X(1 + H_R)}{K} \quad (2a)$$

$$N_X = H_X + \Delta_X = H_X + \frac{H_R(1 + H_R) - H_X(T_K + H_X)}{K} \quad (2b)$$

where  $H_R, H_X$  – raw measuring results of resistance and reactance correspondently;  $N_R, N_X$  –

measuring results after correction;  $\Delta_R$ ,  $\Delta_X$  – correction values;  $K$  – amplifiers open-loop gain on frequency of measuring signal;  $T_K$  – amplifiers time constant.

Figure 4 presents impedance measurement errors before and after correction. The presented results have demonstrated the high efficiency of the correction algorithm. Application of algorithmic correction allows to extend device's bandwidth from 5 kHz to 200 kHz.

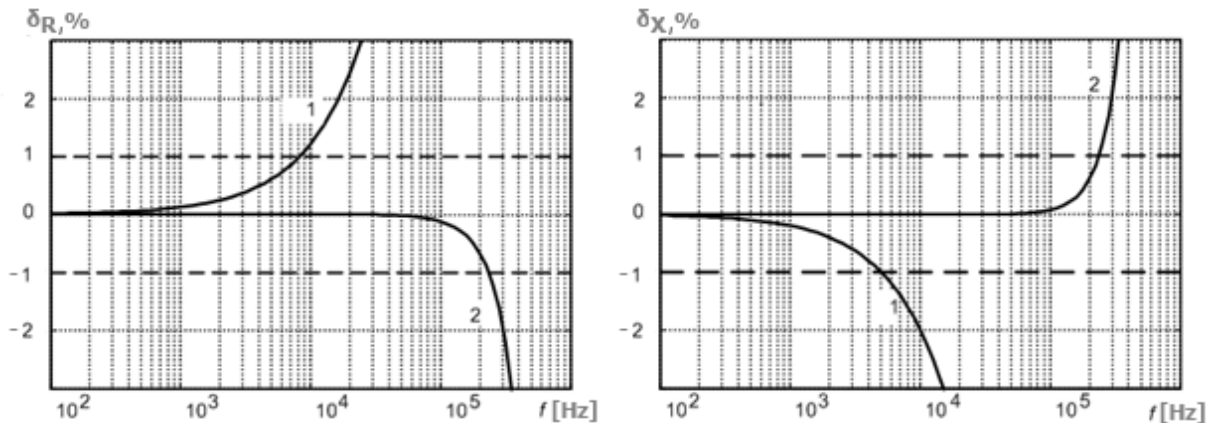

Fig. 4. Dynamic errors of impedance analyzers before (curve 1) and after (curve 2) correction

## 5. CONCLUSIONS

Applications of the portable impedance analyzers, as well as issues associated with their metrological characteristics are presented in the article. The current investigation allows to develop a novel concept to improve the metrological characteristics of portable analyzers. This concept is based on minimizing the analog part of the impedance analyzers' measuring channel and compensating for errors using algorithmic correction and digital signal processing.

Structure of autobalancing measuring circuit has been improved in order to prevent self-oscillations and inductions. Equations for algorithmic corrections of dynamic measuring errors have been developed. Applying algorithmic correction allows to eliminate these errors and thus to improve the accuracy and extend the frequency range.

Advantages of quadrature conversion of measuring signal based on single-point Fourier transform in combination with windowing have been proven. Application of Blackman-Harris window allows to reduce leakage effect and thus to improve precision of quadrature conversion dramatically.

Designed system is able to measure impedance in range from 10  $\Omega$  to 100 k $\Omega$  and perform sweep in frequency band from DC to 200 kHz with step 0.1 Hz. Measurements can be performed only if reactance and resistance varies less than 10 times. For measurements on the frequencies higher than 1 kHz algorithmic correction should be performed. Total system accuracy is 1 %. For example other single-chip portable impedance analyzers (mostly based on impedance-to-digital converter AD5933) have accuracy approximately of 2 % or more.

## REFERENCES

- [1] Grimnes S., Martinsen O.G. Bioimpedance & Bioelectricity Basics. Second Edition: Academic Press, Elsevier, 2008. – 471 p.
- [2] Martinez F.S. Electrical Bioimpedance Cerebral Monitoring: Fundamental Steps towards

- Clinical Application: Thesis for the degree of doctor of philosophy / Chalmers university of technology, Göteborg, Sweden, 2007. –137 p.
- [3] Jaffrin M.Y., Morel H. Body fluid volumes measurements by impedance: A review of bioimpedance spectroscopy (BIS) and bioimpedance analysis (BIA) methods // Medical Engineering & Physics 30 (2008).- p. 1257–1269.
  - [4] Barsoukov E., Macdonald J.R. Impedance spectroscopy: theory, experiment and application. - N.Y.: Willey, 2005. - 595 p.
  - [5] O'Hayre R., Lee M., Prinz F.B, Kalinin S.V. Frequency-Dependent Transport Imaging by Scanning Probe Microscopy // Scanning Probe Microscopy. Springer, 2007. - p. 132-172.
  - [6] Carullo A., Parvis M., Vallan A. Fast impedance analyser for corrosion monitoring // XVI IMEKO World Congress 2000, Vienna, Austria 2000, Vol. VI, TC-10, p. 161-165.
  - [7] Karden E., Buller S., De Doncker R.W. A method for measurement and interpretation of impedance spectra for industrial batteries // J. Power Sources. 2000. Vol. 85. P. 72–78.
  - [8] Goja J., Lentka G. A family of new generation miniaturized impedance analyzers for technical object diagnostics // Metrology and Measurement Systems, Vol. XX, (2013), No. 1, p. 43–52.
  - [9] Agilent 4294A Precision Impedance Analyzer 40 Hz to 110 MHz. Technical Overview / [<http://cp.literature.agilent.com/litweb/pdf/5968-3808E.pdf>]
  - [10] LCR Meters 4260, 4265, 4270. Wayne Kerr Electronics Catalogue / [<http://www.waynekerrtest.com/brochure/4265%20and%204270.pdf>]
  - [11] Impedance/gain-phase Analyzer 1260. Solartron Analytical Brochures / [<http://www.solartronanalytical.com/material-test-systems/Model-1260a-impedance-gain-phase-analyzer-fra.aspx>]
  - [12] 100 KHz LCR Meter MT 4080A / [<http://www.bktw.com.tw/>]
  - [13] Agilent Impedance Measurement Handbook. A guide to measurement technology and techniques: 4-th Edition. Agilent Technologies, Inc. Printed in USA, (2009), 5950-3000. - 140 p.
  - [14] Stadnyk B., Khoma Y., Improving the Accuracy of the Single Chip Impedance Analyzer for Sensor Applications // Sensors and Transducers, vol.150, N.3 March 2013 p.27-31.
  - [15] STM32F405xx/07xx, STM32F415xx/17xx, STM32F42xxx and STM32F43xxx advanced ARM-based 32-bit MCUs. RM0090 Reference manual.
  - [16] Lyons, Richard G. Understanding digital signal processing. – 3-rd ed. Pearson Education, Inc., Ann Arbor, Michigan, 2011. – 954 p.
  - [17] Sean Brennan, Measuring a Loudspeaker Impedance Profile Using AD5933// Analog Devices Application Note AN-843. (www.analog.com).
  - [18] Analog Devices, 1 MSPS, 12-Bit Impedance Converter, Network Analyzer AD5933, Data Sheet, pp. 1-44. (www.analog.com).

## CONTACTS

Prof. Dr.-Ing. habil. B. Stadnyk  
Prof. Dr.-Ing. habil. T. Fröhlich  
**Dr.-Ing. Y. Khoma**

[stadnyk@lp.edu.ua](mailto:stadnyk@lp.edu.ua)  
[thomas.froehlich\(at\)tu-ilmenau.de](mailto:thomas.froehlich(at)tu-ilmenau.de)  
[khoma.yuriy@gmail.com](mailto:khoma.yuriy@gmail.com)