

URN (Paper): [urn:nbn:de:gbv:ilm1-2014iwk-133:2](http://nbn:de:gbv:ilm1-2014iwk-133:2)

58th ILMENAU SCIENTIFIC COLLOQUIUM
Technische Universität Ilmenau, 08 – 12 September
2014 URN: [urn:nbn:de:gbv:ilm1-2014iwk:3](http://nbn:de:gbv:ilm1-2014iwk:3)

IMAGING SENSOR SYSTEM WITH WIRELESS DATA TRANSMISSION FOR IN-PROCESS MEASUREMENTS IN THE MACHINING AREA OF MILLING CENTERS

Mathias Schellhorn, Marc Preißler, Rolf Hoffmann, Gerhard Linß

Technische Universität Ilmenau, Faculty of Mechanical Engineering, Department of Quality Assurance and Industrial Image Processing

ABSTRACT

In the course of progressive rationalization and automation of production it becomes increasingly clear that the traditional spatial and temporal separation of production and metrology is unable to cope the increasing demands of the quality assurance. In addition to the actual measurement time the time for the whole quality circle, starting with the machining of a workpiece through to its metrological determination and finally the use of this information in the production is crucial. Machine-integrated sensor systems which are fully integrated in the flow of information enable early defect detection and thus a reduction of this time. This paper discusses the challenges of the development process at the example of an integrated image processing system for milling machines, which can be loaded via the HSK (hollow shank taper) interface from the tool magazine. The use of optical technology in the work environment is associated with certain obstacles. Since constantly coolant and chips are distributed in the machining area, the sensor system must be protected from pollution. Another major field of research exists in the power supply of the sensor system and the data transfer. Since milling machines already have tool changing devices, it is necessary to adapt these devices to meet the requirements of an additional measurement system.

Index Terms – image processing, in-process metrology, wireless data transmission, quality control loop

1. INTRODUCTION

Machine integrated metrology can be classified by the time the measurement takes place. If a clamped workpiece is measured in the machine prior to machining it is called pre-process metrology. If the measurement is performed after completion of the processing, it is called post-process metrology. If the measurement of the workpiece is performed during machining to close the machine or process control loop within the manufacturing process, one speaks of in-process metrology. [1]

The disadvantage of such a close link is the increasing number of parameters and their effect on the measurement result. Systematic biases that affect the processing procedure and measurement process in the same way (positioning errors, perpendicularity errors, e.g.) cannot be detected. In addition, the cycle time of the machine increased by the duration of the measurements.

Furthermore, in-process measurements offer also enormous benefits.

Through a measurement system with a close connection to the machining process, it is possible to regulate process parameters online. To check and optimize production in machine centers, the critical dimensions of the machined workpieces are controlled. Then required

correction signals on the basis of the measured values are transmitted to the computerized numerical control (CNC). Thus a direct small quality control loop (Figure 1) is formed.

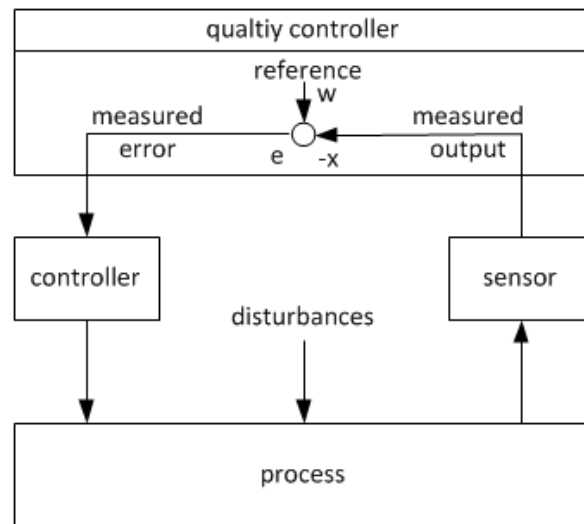

Figure 1: Quality Control Loop [2]

Through small quality control loops, the demands on the availability and the quality requirements for modern production systems (such as the zero-error production) can be achieved. By machine-integrated quality control loops process changes can be corrected as they arise (in-process).

The automated teach-in of the workpiece eliminates the sometimes time-consuming manual alignment of the workpiece and minimizes machine downtimes (pre-process). Workpieces can be tested immediately upon completion of the production process. If discrepancies are found, the workpiece can be reworked without a new set-up process (post-process). Even with the increased cycle times of the machine the throughput time of the production decreases. Unnecessary clamping and set-up times on different machines and paths between production and measurement are avoided.

The machine integrated metrology, which includes pre-, post- and in-process metrology is a way to hedge the narrow process or machine control loops. The integration of measurement systems is a trend to achieve the required high process reliability of future production systems at an early stage and to safeguard the quality of the products. However, there is a high cost pressure for the development of machine-integrated sensor systems which can achieve robust results under production conditions and high noise influence.

1.1 State of the art of machine integrated measurement systems in milling centers

In order to work, a CNC machine requires different coordinate systems. To determine the absolute position of the tool or the workpiece, position measuring systems are coupled to the axes of the machine. Before processing, the relation to the workpiece is determined. Therefore the zero point of the local coordinate system is defined as a reference on the workpiece. State of the art is to equip the machine with an exchangeable tactile stylus in order to sample the surface points. The measurement has to be performed manually by the operator (manual teach in).

In high-end machines, the trend is to use this tactile stylus for rudimentary measurements. This gives the user the possibility to determine the coordinates of individual points and to draw conclusions on the production. However, an extensive, nor yet automated measurement with computer-aided analysis is therefore usually not possible. One exception is the software

“PC-DMIS NC Gage” from Hexagon presented 2013. The manufacturer of coordinate measuring machines and machine centers has the appropriate expertise to drive tactile styluses in their CNC machines. [3]

For dimensional measurements, the workpiece is unclamped and often manually checked with calipers or gauges. For high precision production lines separate measuring devices are available (e.g. coordinate measuring machines).

Another sensor principle that is used in CNC machines is based on a laser. The enveloping diameter and the length of the tool are measured with this laser. As a result, the wear of the tool can be determined. The sensor is permanently installed in the machine and the tool is positioned by the machine within the laser beam. A measurement of the workpiece is not possible with this system.

Optical image sensors have not been used in CNC machining centers so far. A free field of vision, as well as a controlled, appropriate lighting situation is necessary for their use. More difficulty is the relatively large space of camera sensor and lighting, as well as an elaborate protection of the measuring components. The two common sensor classes used in machining centers have the advantage of being relatively insensitive to the conditions in the machine.

2. CONCEPT FOR AN IN-PROCESS MEASUREMENT SYSTEM FOR MILLING CENTERS USING IMAGE PROCESSING

The use of optical metrology directly in production represents a current development trend [4],[5]. It allows a fast feedback of process data and support the elaboration of a profound understanding of the process. Compared with tactile methods where usually only one point is taken, image processing technologies provides many measurement points at once. This results in a huge time advantage, especially for very complex parts where tactile probing is laborious.

To ensure full integration of an imaging sensor system in a machining center, appropriate precautions must be taken during the development of the machine. To solve this task, the competence and expertise of machine manufacturers and research facilities are required. Therefore, a collaboration was initiated in the framework of a joint project. Through its expertise in the field of industrial image processing, the task of the TU Ilmenau includes the hardware design of the sensor system. The aim of the project “In-Prozess-Qualitätssicherung im Maschinenraum von Bearbeitungszentren” is to develop an image processing sensor for in-process measurement in milling machines.

To generate enough data for this lengthy process, in a first step an autonomous sensor for upgrading existing machines is developed. As an approach, the adaptation of the sensor on the machine's internal tool mount is selected. Thus, the sensor can be positioned with the movement axes of the machine. A measurement simultaneously with the production is therefore not possible, but can be automated via the tool changer between processing steps. Due to the lack of power and data cables, however, in addition, the problem arises to power the sensor system and transfer the images to the measurement analysis.

As the tool mount is the only attachment of the sensor, the data must be transmitted wireless. Furthermore, the sensor must have an independent power supply that provides enough power for the measurement.

2.1 System configuration and hardware concept for an image sensor system with wireless data transmission

In the project the standard HSK mount has been set as the basis for further development. The abbreviation HSK stands for "Hohlschaftkegel," which, literally translated into English, means "hollow-shank taper." Among end users it is more commonly referred to as "hollow-

taper-shank tooling". By this definition limit values for weight and design of the proposed sensor arise. The maximum mass of the sensor, including all attachments may not exceed 1kg. The sensor system should be integrated in the tool changer system and must fit in its magazine. It should not exceed a maximum diameter of 160 mm and a height of 200 mm.

After recent attachment to the HSK mount, the sensor system must be operational and be able to perform the image acquisition. Since the HSK mount has no supply lines, the sensor needs to be powered independently by a rechargeable battery. Recharging should take place in the magazine over a charging station. This can be done inductively or via a suitable automatic plug-in system.

The use of battery packs limited the available performance of the sensor system and the duration of the possible measurement cycles. Therefore, we have chosen low-power CMOS technology (complementary metal-oxide-semiconductor) for the design of the camera system. The illumination of the measuring scene is performed by an LED lighting (light-emitting diode), which is designed as a ring light and also must be supplied by the battery. To save energy, lighting and exposure time of the sensor will be synchronized. In addition, a pulse-width modulated (PWM) intensity control is implemented.

The power limitation also eliminates the possibility of a comprehensive image processing within the sensor, which is why the images must be transferred to an external processing unit or processing computer. The interface between sensor system and processing unit represents an important component. To provide connection to image processing standards, we rely on a GigE Vision interface (Gigabit Ethernet for Machine Vision) with GenICam (Generic Interface for Cameras). This allows to transmit bi-directional data and to establish the connection to standard software for image processing. Further, for a wireless transmission standard Wi-Fi components can be used.

Since the sensor forms a closed unit, the lens in use cannot be changed. Thus, to enable a variety of measurement scenarios, a telecentric lens is used to capture objects without perspective distortion. The entrance pupil is located at infinity, so that the main beams in the object space all run parallel to the optical axis. Therefore, the front lens needs to be at least as large as the object to be imaged. As a technical requirement the working distance of the sensor system should be between 100 - 300 mm.

Taken together, the individual components (Figure 2) have to be placed in a housing that can withstand the conditions within the machine.

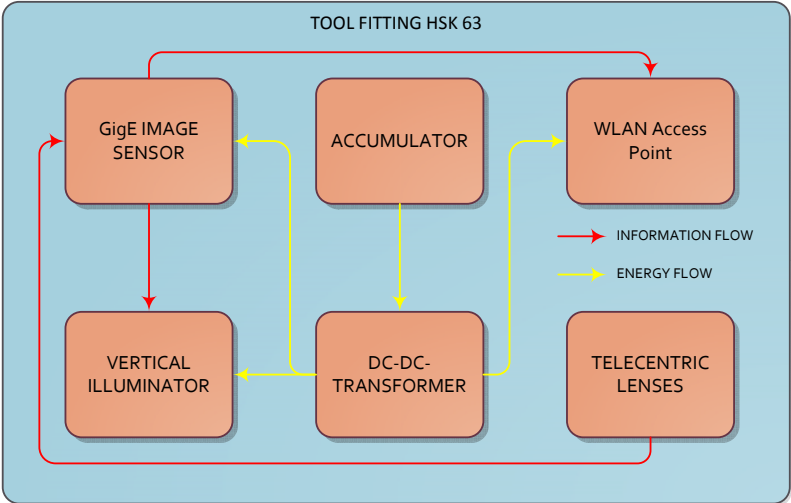

Figure 2: Conceptual component structure for the sensor system

2.2 Environment conditions in the workspace of milling centers

The workspace of a milling center is a hostile environment, especially for optical sensor systems. Through the milling process, dust and ablated chips of different sizes fill the atmosphere and cover the surfaces of everything within the machine. Special hazard potential proceeds from sharp and / or very hot chips that fly off at high speeds (Figure 3 (a)).

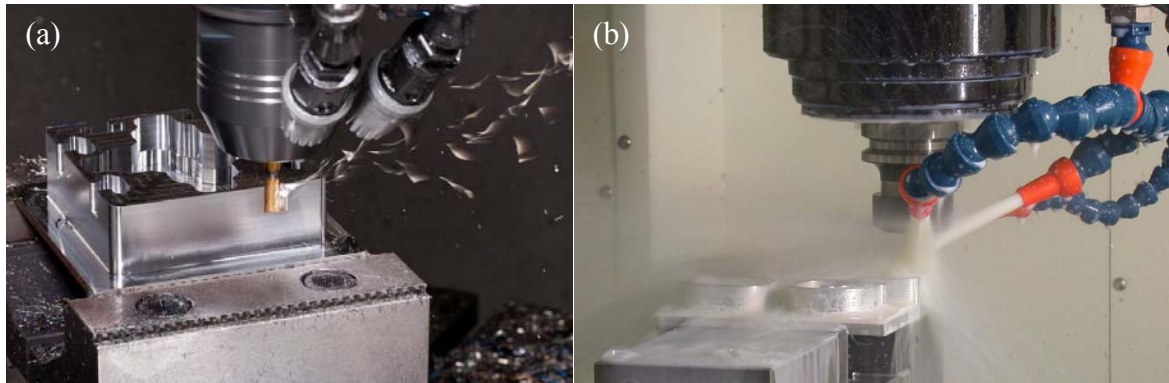

Figure 3: Flying chips (a) and use of cooling lubricant (b) during milling [6]

Aggressive coolant splash around (Figure 3 (b)), the air is saturated by fine spray mist, which connects to the dust as a greasy film. Due to the heat development even aerosols such as coolant vapor can occur. In addition to this pollution, mechanical stress due to vibration and electromagnetic interference (EMI) by the drives must be expected. Environmental protection of the sensor system is therefore a key design consideration.

3. RESULTS AND DISCUSSION

Since the overall design of the sensor system is not yet complete and the production of a technology demonstrator is still pending, only preliminary investigations and decision-making processes can be explained so far. In the present publication, therefore, we restrict ourselves to the selection of the objective, the preliminary studies for wireless data transmission and the design process of the housing.

3.1 Feasibility studies on the selection of suitable lenses

Necessary preliminary investigations have been made regarding a possible large object field and the desired measurement accuracy. Various telecentric lenses with different magnifications were integrated into the optical design. At a selected reference object differentiated characteristics were measured over repeatable repeated measurements. The largest possible field of view aimed to capture larger structures of the test object in the image. This should ensure a high degree of flexibility of the optical sensor system. The achievable accuracy however decreases due to the reduction of the magnification factor. Usable results were achieved with a 1/1,8" image sensor and an object field of 40.2 x 30.3 mm.

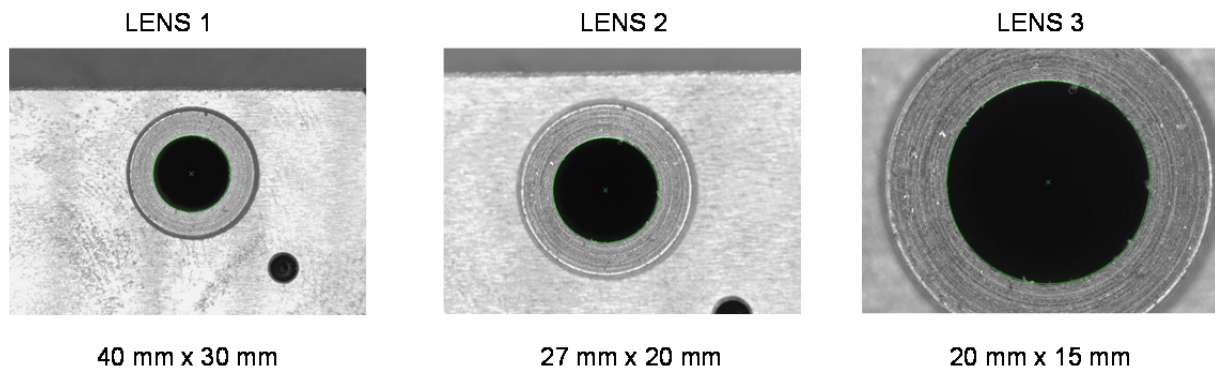

Figure 4: Images of a reference hole taken with different lenses

Experience has shown that high required measurement accuracies are mainly achieved with transmitted light. The approach and the conception of the sensor system allow only a illumination with a reflected lighting system. Satisfactory results were achieved with a 4-quadrant LED ring light, which is confocal oriented.

3.2 Camera integration and investigations for wireless data transmission

For the camera , we could rely on a modular platform developed in our department. Currently, a CMOS image sensor with 1280 x 1024 pixels and 60 frames / s is used. As an interface, the widespread GigE Vision interface is used. The close link to the Ethernet standard offers the possibility to use standard WIFI components. Currently a miniature router of the company TP link is used for the wireless transmission of data. The router support 802.11n at 2.4Ghz with a single antenna.

802.11n achieves per current content stream up to 150 Mbit/s (gross). These data rates can easily be exceeded by cameras with high resolution and frame rate.

$$\begin{aligned}
 \text{data rate} &= \text{resolution} \cdot \text{frame rate} \cdot \text{bit depth} \\
 &= (1280 \cdot 1024) \cdot 60 \frac{1}{s} \cdot 8 \text{ bit} \\
 &= 600 \frac{\text{Mbit}}{s}
 \end{aligned}$$

Even the resulting net data exceeds the maximum possible data rate by a multiple. However, to realize a transmission without image loss, the frame rate must be reduced and a correspondingly large FIFO (First In, First Out) memory implemented. Higher throughput improvements can be achieved by using MIMO (multiple input, multiple output antennas) technology. 802.11n can reach gross data rates up to 600 Mbit/s (net 240 Mbit/s) in 40 MHz mode with four antennas and 400 ns guard interval. However, currently these routers are too large and consume too much power for use in an autonomous sensor system.

3.3 Design and construction of an IP 67 compliant housing for the sensor system

Due to the demanding environmental conditions that prevail within the working area of a machine (see section 2.2), the individual components of the sensor system must be absolutely protected from moisture and other contaminants. During the design and construction phase, therefore a robust design was pursued which meets the requirements for IP67 protection. The IP protection rating system is a standard defined in international standard IEC 60529. This rating system classifies the degree of protection provided by an electrical equipment enclosure against solid objects and liquids (water, coolant, oil, etc.).

With an IP67 rating, the housing must be dustproof and protected against temporary submersion into fluids. Here, the challenge is the development of appropriate mechanisms for the protection of the optical components (lens, lighting) which do not affect the basic function of image acquisition. Therefore different protection mechanisms have been considered. In a first design study, the use of a swiveling lens cover has been integrated (Figure 5). Both the use of a mechanical iris or self-cleaning with stain-resistant surfaces or air pressure was evaluated. However the final implementation still depends on the overall structure of the internal components.

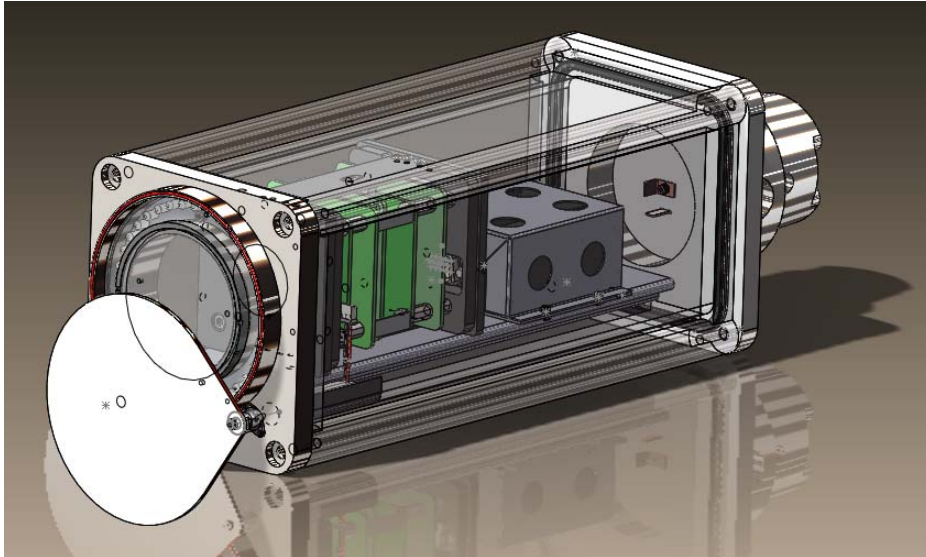

Figure 5: Early design study for the IP67 housing with swiveling lens cover

4. CONCLUSIONS

Since the response times for a process control in the production are relatively low, speed is a critical challenge to the in-line measurement. Nevertheless, the features must be measured with a correspondingly low measurement uncertainty under production conditions. Thus two features are essential for an applicable measurement system: robustness and speed.

Here, especially of image processing based measurement systems are suitable because they meet the requirements of process-oriented applications. Large amounts of measurement points can be detected by non-contact measurement with image processing sensors. They are fast and are characterized mainly by a high degree of flexibility, which can still be increased through the inclusion of existing positioning systems.

The use of image processing sensors has so far not used in milling machines and offers great potential for innovation. The stated goal of integrating a sensor system without major adjustment in a machine center provides the basis to perform quality assurance during the machining process in almost any machine using a tool change system.

The use of optical technology in the work environment is associated with certain obstacles. As the milling process constantly spread chips and foreign objects in the workspace and the milling head is supplied with coolant, the sensor head must be designed so that it is protected against pollution. The autonomous power supply of the sensor system represents a major challenge. Especially lighting and image processing must be controlled intelligently and efficiently. Due to lack of data lines, the measured value or images must be transferred wireless.

Despite these technical obstacles, however, enormous economic benefits can be achieved. CNC machines have high-precision positioning systems in order to maintain the required manufacturing tolerances. The innovation is to integrate advanced measuring systems in the machining area of milling machines and to lift the fusion of both technologies to a new level.

5. Acknowledgments

This research was supported by the Free State of Thuringia, the European Regional Development Fund (EFRE) of the European Union and the Thüringer Aufbaubank (TAB) under the support code 2013 FE 9025. We would also like to thank the project partners GFE - Gesellschaft für Fertigungstechnik und Entwicklung Schmalkalden e.V., SAMAG Saalfelder Werkzeugmaschinen GmbH, -4H-JENA engineering GmbH and FKT Formenbau und Kunststofftechnik GmbH for their dedication.

REFERENCES

- [1] A.Weckenmann et.al.: „*Koordinatenmesstechnik: Flexible Meßstrategien für Maß, Form und Lage*“ 2nd edition, Carl Hanser Verlag GmbH Co KG, München, p 224, 1999.
- [2] G.Linß et. al.: „*Qualitätsmanagement für Ingenieure*“ 3rd edition, Carl Hanser Verlag GmbH Co KG, München, p 24, 2011.
- [3] Hexagon Metrology: „*PC-DMIS NC GAGE SOFTWARE - Measuring on Machine Tools – easy and precise*“, product brochure, Hexagon Metrology, 2013.
- [4] M. Rosenberger; M. Schellhorn; G.Linß; M.Schumann; P.Werner; S.Lübbecke: “*Quality control for springs during the production process based on image processing technologies*” - In: Proceedings / IMCIC '10; ICSIT 2010; icEME 2010, Internat. Inst. of Informatics and Systemics. Orlando (Florida), USA, 2010.
- [5] M.Schumann; J.Bargenda; A.Schlegel; P.Werner; E.Reetz; M.Rosenberger; G.Linß: “*Measuring edges on pivot-mounted objects during rotation*” - In: Advanced mathematical and computational tools in metrology and testing IX / International Conference on Advanced Mathematical and Computational Tools in Metrology and Testing; World Scientific Publ., Singapore, p. 358-365, 2012.
- [6] Photograph taken by Glenn McKechnie, licensed under the Creative Commons Attribution - Share Alike 2.0 Generic.

CONTACTS

Dipl.-Ing. M. Schellhorn

Dipl.-Ing. M. Preißler

Dipl.-Inf. R. Hoffmann

Univ.-Prof. Dr.-Ing. habil. G. Linß

mathias.schellhorn@tu-ilmenau.de

marc.preissler@tu-ilmenau.de

rolf.hoffmann@tu-ilmenau.de

gerhard.linss@tu-ilmenau.de