

## SSC19-WKIII-09

**On-orbit Operation Results of the World's First CubeSat XI-IV  
- Lessons Learned from Its Successful 15-years Space Flight -**

Ryu Funase, Satoshi Ikari, Ryo Suzumoto  
The University of Tokyo  
7-3-1 Hongo, Bunkyo-ku, Tokyo 113-8656, Japan; +81-3-5841-0742  
funase@space.t.u-tokyo.ac.jp

Nobutada Sako  
Canon Electronics Inc.  
3-5-10, Shibakoen, Minato-ku, Tokyo 105-0011, Japan; +81-3-6910-1105  
sako.nobutada@canon-elec.co.jp

Masahiro Sanada  
Amateur radio operator (call sign: jilizr)  
jilizr@jamsat.or.jp

Shinichi Nakasuka  
The University of Tokyo  
7-3-1 Hongo, Bunkyo-ku, Tokyo 113-8656, Japan; +81-3-5841-6590  
nakasuka@space.t.u-tokyo.ac.jp

**ABSTRACT**

In recent years, the size and cost of satellites have been reduced, and the frequent launch of satellites have been realized even by small private companies and universities. The first step of this big wave was the first successful launch of CubeSats, 1kg nano-satellites, in June 2003. One of the CubeSats was XI-IV, which was developed by Intelligent Space Systems Laboratory (ISSL) of the University of Tokyo. Its mission was the world's first on-orbit demonstration of the CubeSat bus system. Due to the spatial, power and cost constraints, most of the bus system was composed of low-cost COTS parts, and a "cross-check" type fault redundancy system against the radiation effects was implemented to achieve as better reliability as possible within the resource constraints. Since the successful launch by the ROCKOT launch vehicle from Russia, the satellite has been in normal operation for over fifteen years since the launch (as of June 2019). The operation has been jointly conducted by the University of Tokyo and amateur radio operators in Japan. This paper reports its more-than-15-years world's longest CubeSat operation results and the lessons learned from it.

**INTRODUCTION**

Micro/nano/pico-satellites with mass less than 100kg are now making a significant game change in space development and utilization. Because of their strong features of extremely low cost and very short quick development time, these satellites are beginning to replace mid or large sized satellites where intended missions can be realized even by small-scale satellites. Many venture companies are appearing, which have grown first by the governmental fund and then successfully collected risk money from private sectors, are now playing some of the important roles in space utilization, including Earth observation, space sciences and explorations, micro-gravity experiment, communications, entertainment, and educations, etc. It is predicted that more than 400 satellites less than 50kg will be launched every year from now on.

One of the triggering events for these tremendous growths of micro/nano/pico-satellites was the success of the launch and operations of the first several CubeSats in orbit. From Japan, two CubeSats "XI-IV (pronounced sai four)" and "CUTE-I" made by the

University of Tokyo<sup>1</sup> and the Tokyo Institute of Technology respectively participated in the world first CubeSat launch by ROCKOT on June 30th, 2003. XI-IV succeeded in all the planned experiments and have been surviving for more than 15 years in orbit, which paved the way towards practical usages for such small scaled satellites. This paper describes the design strategy of the University of Tokyo's first CubeSat "XI-IV" and its 15 years' history in orbit.

**CANSAT PROJECTS AS THE FIRST STEP TRAINING BEFORE CUBESAT**

University of Tokyo's team did not rush into real satellite projects but first gained experiences and know-how by educational "CanSat" projects, a satellite in a 350ml juice can.<sup>2</sup> The CanSat project is a program that was put forward at the University Space Systems Symposium (USSS) in 1998 by Professor Bob Twiggs from Stanford University. The initial plan was to get individual universities to make satellites with the size of a 350ml drinks can and then launch them all into orbit. Due to difficulties securing a means of launching the satellites into orbit, however, this was revised to a plan

called ARLISS (A Rocket Launch for International Student Satellites) involving launching the satellites to an altitude of approximately 4km using solid rockets provided by amateur rocket groups. Launch experiments have been held in the Black Rock Desert in the US state of Nevada every year since 1999. Initially, the only participants from Japan were the University of Tokyo and the Tokyo Institute of Technology, but 2018 saw a total of 12 Japanese, Korean and USA universities take part in what was a major experiment involving the launch of 45 rockets. Figure 1 shows the University of Tokyo's three CanSats from the first year.

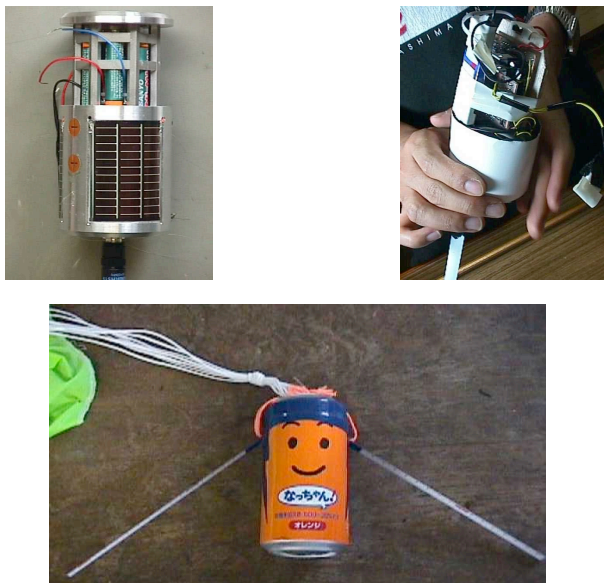

**Figure 1: The University of Tokyo's three CanSats from 1999 (the first year of ARLISS)**

After being released from a rocket at an altitude of approximately 4km, the CanSats open their parachutes and then take around 15 to 20 minutes to descend to the earth's surface. During this time a range of experiments is carried out, including communication experiments with earth stations on the ground and demonstration experiments to test satellite equipment at the stage before being launched into orbit, all of which have enabled us to obtain significant results. Individual universities have also conducted their own elaborate experiments, including experiments to obtain images from cameras pointed in a fixed direction, formation flight experiments involving multiple satellites and tethered satellite experiments, as each university has continued to strive to improve satellite technology within its own specialist field. The event has featured a Comeback Competition since 2001 to see which CanSat can land and reach closest to a specified destination once released with no outside assistance, just using GPS and parafoil capabilities. A small autonomous rover equipped with GPS was also allowed, which separates

its parachute and runs towards the goal after landing on the ground. This has increased student's motivation even further, as well as improving the level of technology.

### AN OUTLINE OF THE UNIVERSITY OF TOKYO'S CUBESAT "XI-IV"

CubeSat is a project put forward by Professor Bob Twiggs from Stanford University in USSS 1999, involving standard sized pico-satellites weighing 1kg or less. This 1U size only was initially considered to be "CubeSat," though currently satellites consisting of multiple units of 10x10x10cm sizes are also called "CubeSats." Although the project's primary objective was educational, due to the fact that CubeSats can be developed inexpensively in the exceptionally short period of time of one to two years, there are high hopes that they will pave the way for a new dimension in space exploration as a platform for quickly conducting tests on new technology in space and for various practical space missions and business. Because of these strong features, now there are more than 100 universities, space agencies, venture companies, and governmental institutes around the world working on independent projects. The University of Tokyo and the Tokyo Institute of Technology were first to complete their satellites, becoming the first to launch CubeSats in June 2003.

The main aims of the University of Tokyo's CubeSat program, which is called XI (pronounced "sai," short for X-factor Investigator) as shown in Figure 2 are to further space engineering education and to test ultra-small satellite bus technology in orbit.<sup>3</sup> Except for its solar batteries, it exclusively uses commercially available products and has the important mission of both verifying how they behave in orbit and laying the foundations for future micro/nano/pico-satellite development. Different from the current CubeSat situation when everyone can buy CubeSat components easily from web sites, no off-the-shelf commercial components for CubeSats were available at that time, which forced the team to develop all the components in-house or by collaboration with private companies (such as communication module).

The University of Tokyo is looking into remote sensing as one compelling mission that could be performed by micro/nano/pico-satellite. As the first step towards this goal, XI-IV was also assigned an advanced mission entailing obtaining and downlinking images of Earth using a miniature CMOS camera. Two flight models (FM), called XI-IV and XI-V were developed together with the same design, with our intention to select one for launch and the other for backup to be kept on the

ground which would be used for troubleshooting when some anomaly occurs in the FM in orbit.

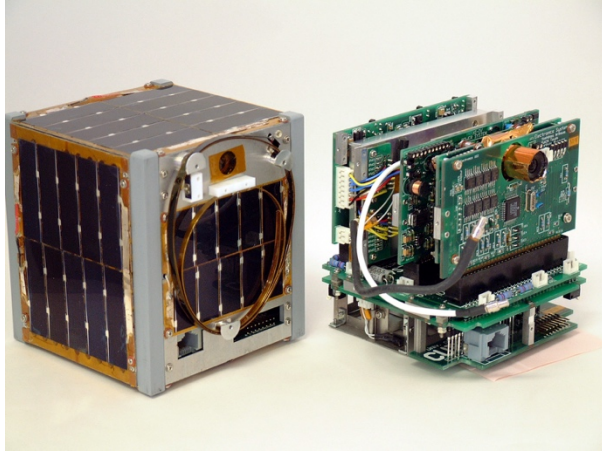

**Figure 2: The University of Tokyo's CubeSat-XI (left: external appearance, right: internal structure)**

#### XI-IV'S SPECIFICATIONS AND MISSION

The specifications of CubeSat XI-IV, which was designed for the initial launch, are detailed in Table 1 below. Of all the satellites whose size and weight has been disclosed, it is the smallest and lightest in the world at that time. All the parts are commercially available products except for solar cells, meaning that it was developed at an exceedingly low cost.

**Table 1: CubeSat XI-IV's basic specifications**

Size	10 × 10 × 10cm <sup>3</sup>
Mass	1kg
C&DH System	
OBC	PIC16LF877, 8bit, 4MHz
Storage	EEPROM 256kbyte
Communication system	
Uplink command	144MHz band, FM, 1200bps
Telemetry downlink	430MHz band, FM, 1200bps, 0.8W
Beacon downlink	430MHz band, CW, 80mW
Antenna	Monopole (up), Dipole (down)
Power supply system	
Solar cell	Single crystal silicone, 1.1W (average)
Secondary battery	Lithium ion batteries, 6.2AH
Attitude control system	Passive magnetic field aligned control
Sensors	Temperature, voltage, current, CMOS camera

It uses an amateur radio frequency band for communication. The transceiver was developed in collaboration with a private company, which has since

been used by a large number of other universities. The beacons and downlink format were released to the public to enable cooperation from amateur radio operators around the world. The solar cells were single crystal silicone with 16% efficiency based on space specifications. Although active attitude control was initially considered, it was deemed to be difficult to equip a 10 x 10 x 10cm satellite with an active attitude control system at that time. Consequently, passive attitude control was used, involving fitting a permanent magnet and a hysteresis damper designed to point the satellite in a geomagnetic direction. This is also why the solar cells were mounted on all the body surfaces rather than on wings. These decisions reflected the experiences of other countries, whereby micro-satellites weighing 50kg or less based on a system of three-axis attitude control and solar paddles had frequently failed in the past as a result of insufficient solar power generation due to anomalies of their three-axis attitude control system.

The decision was made to use and test lithium-ion batteries (to be used in mobile phone), which had hardly been used in space previously at that time, due to their high levels of efficiency. The antenna was coiled up on the side and held in place with fishing wire for the launch, using a system whereby the fishing wire would be cut using nichrome line after separation. This is a method commonly used in the field of micro/nano/pico-satellites as it is simple, low impact and relatively reliable.

The separation mechanism was also developed independently. CubeSat is inserted inside a box-type separation mechanism as shown in Figure 3 and is pushed out by a spring when the spring-loaded door is opened using a nichrome line system to cut through the fishing wire when given the signal to do so by the rocket.



**Figure 3: CubeSat XI-IV's separation mechanism**

## ASSURANCE OF SURVIVABILITY IN SPACE

Even for a satellite as small as 1U CubeSat, it would be essential to take every effort to make the satellite system survive in orbit as long as possible to fulfill the mission. In XI-IV, the following countermeasures against anomalies in orbit were designed (Figure 4)

1. Radiation tests were conducted for various candidate CPUs with support from NASDA (former JAXA) using Californium radioisotope, and PIC16LF877 was found very robust against Single Event Effects (SEE), which was selected for the main CPU. We did not expect a long in-orbit lifetime of XI-IV, TID (Total Ionizing Dose) test was not conducted. Another reason to select it was that its normal power consumption was very small such as less than 10mW.
2. Each of the three subsystems, namely OBC-system (Onboard Computer), TX-system (Transmitter), CWRX-system (CW beacon + Receiver) has PIC16LF877 which is usually conducting tasks related to each subsystem respectively.
3. In addition to that, each CPU is watching the behavior of the other subsystem's CPU, and when it detects an anomaly of the other CPU, it resets (turn OFF and ON) the other subsystems. As shown in Fig. 4, CPU in OBC-system can reset both of the other two subsystems, and CPU in CWRX-system can reset OBC-system.
4. The CPU in OBC-system is also monitoring the power supply lines to the other two subsystems, and when it detects excess current in those lines, then it resets the related subsystem. On the other hand, the CPU in RX-system is watching the excess current of OBC-system and resets it when it detects excess current in the line to OBC-system.
5. Even if all the functions are normal, the power line is reset roughly every week, which serves as the last resort for the sever anomaly such as hung-ups of all the system.

All the required space environment tests were carried out to assure the normal functionality of XI-IV in space, including SEE radiation test, thermal test, thermal vacuum test, vibration test, and shock test. As the communication components were the newly developed ones, a long-range communication test was carried out in 2001 using JAXA/ISAS's balloon. This balloon lifted the communication payload up to 40km height above the northern part of Japan so that direct in-sight communication test could be realized between this

payload and the University of Tokyo's ground station over 500km distance.

It was in a sense very fortunate for us that as XI-IV had to wait for several months after its completion until launch, we could conduct long duration "burn-in" test, also with the objectives of operation training of the students, which found several errors in software and improved the reliability of the satellite very much.

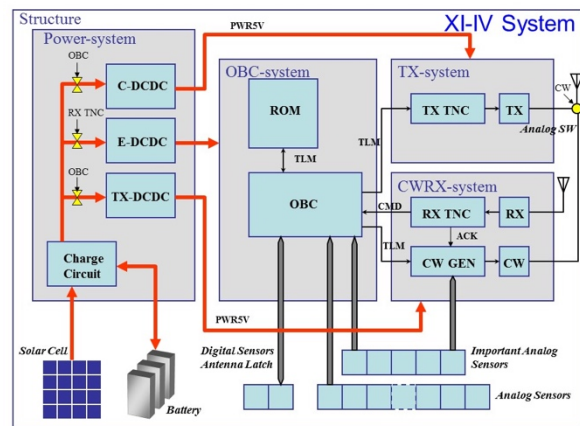

Figure 4: System block diagram of XI-IV

## THE LAUNCH AND INITIAL OPERATIONAL RESULTS

CubeSat XI-IV was launched from Plesetsk in Russia at 11:15 pm (Japan time) on June 30, 2003, using a three-stage rocket called "ROCKOT" provided by a company "Eurokot." At 0:48 am on the following day, XI-IV was successfully delivered into a sun-synchronous orbit at an altitude of 824km. In addition to the University of Tokyo's CubeSat, the same rocket also carried CUTE-I (the Tokyo Institute of Technology's CubeSat), two 1U CubeSats from Denmark and one from Canada, a US satellite with the size of 3U CubeSat called QuakeSat and two 60kg-class satellites called Mimosa and MOST. BREEZE-KM, the upper stage of the rocket, launched these satellites into their designated orbits in sequence. As XI-IV passed over Japan for the first time at 4:36 am on July 1, a CW beacon from XI-IV was received by the ground station at the University of Tokyo and the Sugadaira ground station owned by University of Electro-Communications, confirming that the satellite had been launched into orbit without any problems and was functioning normally including the onboard antenna deployment.

The first task in the operation was to identify XI-IV's orbit. With the help of amateur radio operators all over the world, an analysis was carried out to ascertain which of the eight objects picked up by the NORAD

radar was which satellite based on data such as Doppler shift, enabling identification within roughly one week.

Telemetry downlinks from the satellite containing data such as the temperature, solar battery power generation, and battery voltage confirmed that things were as planned.

**SUMMARY OF 15-YEARS OPERATION RESULTS AND LESSONS LEARNED**

The satellite worked well, and a lot of newly developed technologies described in the previous section were demonstrated. The communication between the satellite and the ground station has been smooth since the launch, which means the transmitter/receiver based on COTS components proved to work in the space environment. Other COTS components such as CPUs have also been working correctly.

XI-V, the backup model for XI-IV, played an essential role as “a simulator” on the ground. Once when XI-IV was behaving anomalously in orbit, XI-V was used for troubleshooting of XI-IV by trying to generate the similar symptoms on XI-V. By these trials, finally, it was found that this anomaly was coming from a minor error of onboard software, which only appeared on rare occasions and so did not have to be considered seriously. We gained an experience that a ground backup satellite model was extremely useful for such troubleshooting. After completing its role as the backup model for XI-IV, we implemented XI-V with new technology demonstration missions and launched it in 2005.<sup>4</sup>

**Trend of Li-ion battery performance**

The Li-ion batteries have been working correctly in the cold and vacuum space environment. Figure 5 shows the trend of the battery voltage during the 15 years in orbit.

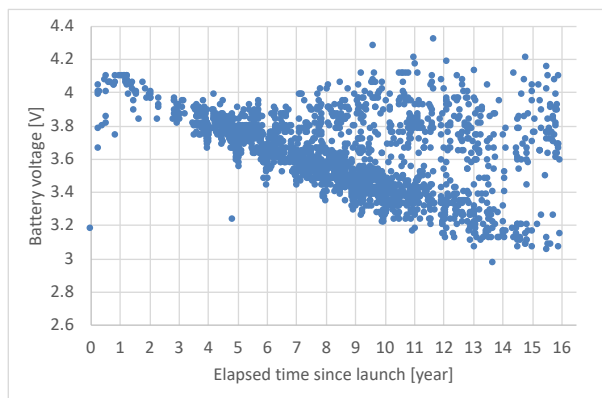
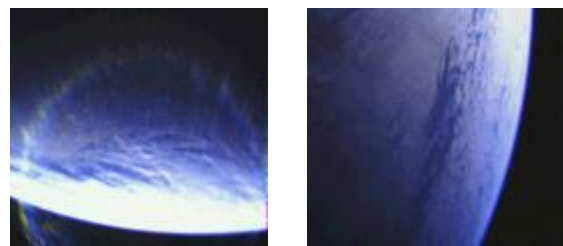

**Figure 5: 15-years trend of battery voltage**

XI-IV was inserted into a dawn-dusk orbit by the launch vehicle. In this orbit, the battery is only discharged after the high-power operation such as telemetry downlink and/or when the satellite enters into occasional (seasonal) shadow area depending on the seasons during the year. Even if the depth of discharge (DOD) of the battery was initially very small, the battery seems to be gradually degrading year by year, and the minimum battery voltage has been continuously decreasing. This phenomenon is considered to be because of the increase of the internal impedance of the battery cell due to the large number of charge/discharge cycles.

**Captured images by a COTS CMOS camera module**

XI-IV is equipped with a COTS CMOS camera module, which has successfully taken and downlinked more than 700 images over the 15 years. Figure 6 shows two examples of the earth images obtained in 2003. In order to make the general public aware of the significance of space development as well as enjoy the beautiful earth images, the students initiated an outreach project to deliver via the internet the current status of XI-IV and the obtained images to the PCs and mobile phones of those who registered e-mail addresses on our website. This service became very popular and more than 1500 people were waiting for our CubeSat's voice and sight. Many who were impressed by the images kindly have sent us e-mails including their impressions, anticipations and cheering messages, which shows that this project contributed a lot to the space outreach activities.

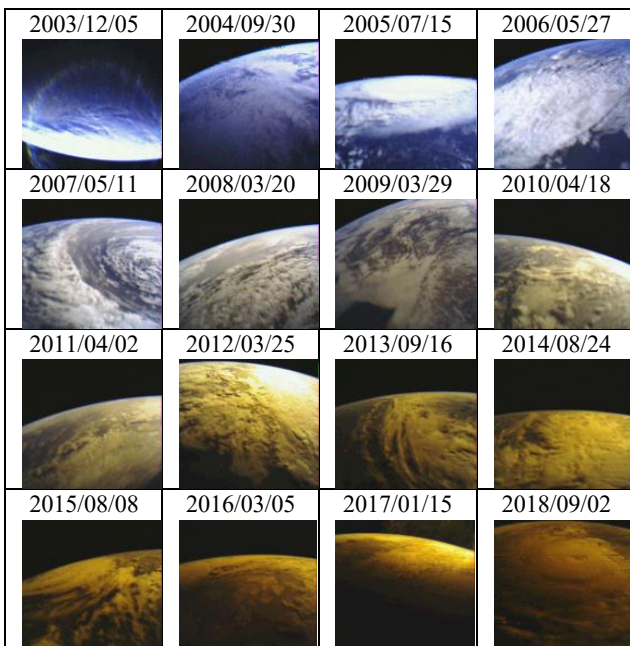

**Figure 6: Examples of the earth’s images captured in 2003**

We selected 16 pictures of the earth where most of the areas covered with blight clouds and arranged them in chronological order in Figure 7. The pictures during the early years are beautiful and bluish, just as we currently see the earth. Then, the images got yellower after 2007.

Since a digital picture consists of RGB data, we analyzed the trend in the 16 pictures in terms of their RGB values as an index. We used a simple image processing software, “ImageJ”.<sup>5</sup> It can calculate the mean values of Intensity, Red, Green and Blue for each pictures. As in Figure 8, the intensity of the images

shows a downward trend. In order to analyze the color while the images are getting dark, we analyzed the trend of R, G and B values divided by the Intensity of the image as in Figure 9. The results show that the color phase has changed from blue to red and green, or “brown”, which is consistent with what we “see” the images. The observations about the images suggest that even a low-cost plastic lens for the COTS camera module can endure the space environment for about 5 years.



**Figure 7: Selected 16 pictures of the earth captured in each year since 2003 with its captured time (yyyy/mm/dd, Japan Standard Time)**

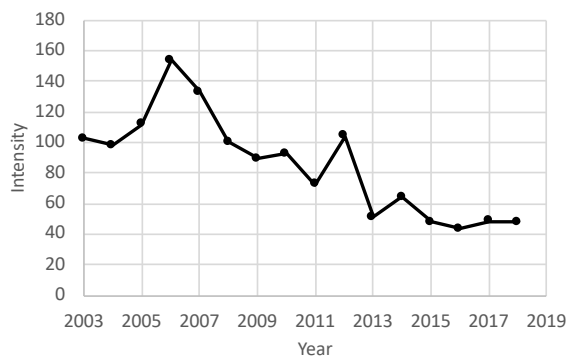

**Figure 8: Trend of the intensity for the selected 16 images**

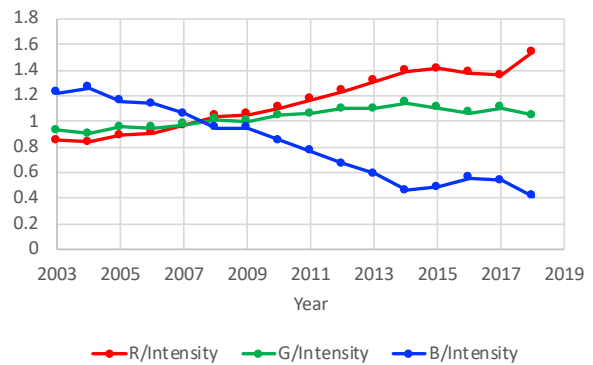

**Figure 9: Trend of R, G and B mean values divided by the Intensity for the selected 16 images**

**Why we could continue operation this long time?**

XI-IV has been operational for over 16 years since the launch in 2003. XI-IV accomplished one of the world’s first successful launch and operation of CubeSats, and it has been breaking the longest operation records for CubeSats. One of the major reasons why this satellite has been operation for this long time is that the good reliability against the radiation environment was achieved by the cross-check redundancy system described in this paper. Besides the implemented measures against the space radiation, the team completed intensive functional/performance tests before launch for the world’s first launch opportunity of CubeSat, which eliminated the possibility of initial failure of electrical and electronic parts as much as possible and is considered to contribute to this long lifetime.

To continue the operation for over 16 years has been also a big challenge for the personnel on the ground. One of the major factors that made this possible was the continuous improvement of the software that we use for the operation, which drastically reduced the operator’s work load. For example, we developed a software for the operator to generate necessary uplink commands and analyze the downlinked image data. Using this software, we were able to decide what data has been already successfully downlinked and what was not, and semi-automatically generate the necessary commands to complete the remaining part of the image even during the operation pass. Such semi-automatic operation was quite helpful for the efficient operation, as the telecommunication for the amateur radio satellites like XI-IV tend to be interrupted by various noise sources and the transmitted data from the satellite was often missing.

Another major factor was the great support from the amateur radio community. In the telecommunication environment with much interference as described before, it was quite helpful that a lot of amateur radio operators received the telemetry data from XI-IV and provided the data to the XI-IV operation team. In order to foster the support from as many as amateur radio operators, we built the system so that the amateur radio operators and XI-IV operation team can exchange and share the received data through internet in real time during the operation. By using this system, the operators from various places can not only exchange the data through a server in the University of Tokyo but also “chat” with each other via the server. The members only sent the data to the project team on one way in former times. But the new system let all the members to send or receive the data and the information on each other. Being able to be deeply involved in the real satellite operations is a very important and valuable opportunity for amateur radio operators, and this is considered to be a win-win case for both the XI-IV operation team and the amateur radio operators.

## CONCLUSION

Recently, not only governmental organizations but also even a number of private companies, universities, etc. has been building nano-satellites (1–10 kg) and micro-satellites (~50 kg), and part of the satellites started to be utilized for business use.

One of the triggering events for these tremendous growths of micro/nano/pico-satellites was the successful launch and operations of the first several CubeSats in orbit. From Japan, two CubeSats, “XI-IV” and “CUTE-I” by the University of Tokyo and the Tokyo Institute of Technology respectively, participated in the world’s first CubeSat launch by ROCKOT on June 30th, 2003.

Except for its solar cells, XI-IV exclusively uses commercially available electric parts and has the important mission of both verifying how they behave in orbit and laying the foundations for future micro/nano/pico-satellite development. Different from the current CubeSat situation when everyone can buy CubeSat components easily from all over the world, no off-the-shelf commercial components for CubeSats were available at the time of development (around 2000), which forced us to develop all the components in-house or by collaboration with private companies (such as communication module). Besides conducting necessary environmental tests for the engineering model and flight model, we designed and implemented a “cross-check” redundancy system in order for the satellite using much commercially available parts with severe spatial/power constraints to survive in space.

Owing to the deliberated design to achieve as highest survivability as possible and the extensive tests, XI-IV succeeded in all the planned experiments and the satellite has been surviving the space environment for more than 16 years. It is surprising that the world’s first CubeSat also has the world’s longest operation record and has been breaking the record even now. Although some degradation on the battery performance has appeared, several more years of operation will be expected.

Another important factor which enabled this long-time operation was that the operation team has received much support from the amateur radio community. This first-ever CubeSat attained much interest from many amateur radio operators all over the world, and owing to the developed data collection system where the participating amateur radio operators and XI-IV operation team can exchange and share the received data through internet in real time during the operation, XI-IV operation team has received considerable support from the community for more than 16 years.

As the first CubeSat in the world, XI-IV from the University of Tokyo has paved the way towards the practical usages of micro-/nano- scaled satellites. Its lessons learned from the development and 16 years of operation was that the extensive tests, elaborated design to improve survivability as much as possible, and to receive supports from the stakeholders all over the world has been still the key to the success of CubeSat missions even in this period when 16 years have passed since the first launch of CubeSats in 2003.

## Acknowledgments

The authors would like to show their greatest appreciation to a lot of amateur radio operators in the world. The successful operation of XI-IV has never been achieved without their enormous contributions.

## References

1. University of Tokyo Intelligent Space Systems Laboratory’s website:  
<http://www.space.t.u-tokyo.ac.jp>
2. Shinichi Nakasuka, Nobutada Sako, Hironori Sahara, Yuya Nakamura, Takashi Eishima, and Mitsuhiro Komatsu, “Evolution from Education to Practical Use in University of Tokyo’s Nano-satellite Activities,” *Acta Astronautica*, Vol.66, Issues 7-8, pp.1099-1105, 2010.
3. Yuichi Tsuda, Nobutada Sako, Takashi Eishima, Takahiro Ito, Yoshihisa Arikawa, Norihide Miyamura, Akira Tanaka and Shinichi Nakasuka, “University of Tokyo’s CubeSat Project —

Mission Concept and Subsystem Design —,”  
*Journal of Space Technology and Science*, Vol.16,  
No.1, pp.1\_37-1\_46, 2000.

4. Ryu Funase, Yuya Nakamura, Masaki Nagai, Akito Enokuchi, Mitsuhito Komatsu, Shinichi Nakasuka and Shirou Kawakita, “Development of COTS-based Pico-Satellite Bus and Its Application to Quick and Low Cost On-orbit Demonstration of Novel Space Technology,” *Transactions of the Japan Society for Aeronautical and Space Sciences, Space Technology Japan*, Vol.6, pp.1-9, 2008.
5. ImageJ, <https://imagej.nih.gov/ij/index.html>, accessed on July 11th, 2019.