

# **GENETICS OF BREAST AND OVARIAN CANCER PREDISPOSITION WITH A FOCUS ON *RAD51C* AND *RAD51D* GENES**

**Liisa Pelttari**

Department of Obstetrics and Gynecology  
Helsinki University Hospital

Doctoral Program in Biomedicine  
Faculty of Medicine  
University of Helsinki  
Helsinki, Finland

ACADEMIC DISSERTATION

To be presented, with the permission of the Faculty of Medicine of the University of Helsinki, for public examination in Lecture Hall 3, Biomedicum Helsinki 1, on August 24<sup>th</sup> 2018, at 12 noon.

Helsinki 2018

**Supervised by** Docent Heli Nevanlinna, PhD  
Department of Obstetrics and Gynecology  
Helsinki University Hospital  
University of Helsinki  
Helsinki, Finland

**Reviewed by** Docent Csilla Sipeky, PhD  
Institute of Biomedicine  
University of Turku  
Turku, Finland

Docent Sirpa Kivirikko, MD, PhD  
HUSLAB Department of Clinical Genetics  
Helsinki University Hospital  
Helsinki, Finland

**Official Opponent** Docent Annika Auranen, MD, PhD  
University of Turku, Finland  
Department of Obstetrics and Gynecology  
Tampere University Hospital  
Tampere, Finland

*Dissertationes Scholae Doctoralis Ad Sanitatem Investigandam Universitatis Helsinkiensis*

ISBN 978-951-51-4374-7 (Paperback)

ISBN 978-951-51-4375-4 (PDF)

ISSN 2342-3161 (Print)

ISSN 2342-317X (Online)

Unigrafia  
Helsinki 2018

# CONTENTS

List of original publications .....	5
Abbreviations.....	6
Abstract.....	8
1 Introduction.....	10
2 Review of the literature.....	11
2.1 Biology of cancer.....	11
2.1.1 DNA damage repair .....	12
2.2 Cancer genes .....	13
2.2.1 Hereditary predisposition to cancer .....	15
2.3 Breast cancer .....	15
2.3.1 Breast cancer classification and subtypes.....	16
2.3.2 Breast cancer risk factors.....	18
2.4 Ovarian cancer .....	19
2.4.1 Ovarian cancer classification and subtypes.....	19
2.4.2 Ovarian cancer risk factors and prevention strategies.....	21
2.5 Breast and ovarian cancer susceptibility genes .....	22
2.5.1 High-penetrance genes.....	23
2.5.2 Moderate-penetrance genes .....	26
2.5.3 Low-penetrance variants .....	28
2.5.4 Finnish founder mutations.....	29
2.6 Inherited susceptibility to prostate cancer .....	30
2.7 Inherited susceptibility to colorectal cancer.....	30
2.8 RAD51 paralogs.....	31
2.8.1 RAD51C.....	32
2.8.2 RAD51D .....	33
2.9 RAD54L.....	34
2.10 Next-generation sequencing in cancer research and diagnostics.....	34
3 Aims of the study .....	36
4 Materials and methods .....	37
4.1 Subjects.....	37
4.1.1 Helsinki breast and ovarian cancer series (I, II, IV).....	37
4.1.2 Gene-panel sequencing samples (IV).....	38
4.1.3 Tampere breast cancer series (I, III) .....	39
4.1.4 Prostate cancer series (II, III).....	39
4.1.5 Colorectal cancer series (II, III).....	39
4.1.6 Population controls (I, II, IV) .....	39
4.2 Mutation analysis .....	39

4.2.1	Gene-panel sequencing (IV).....	39
4.2.2	Sanger sequencing (I, II, IV).....	40
4.2.3	Genotyping (I-IV).....	40
4.3	Loss-of-heterozygosity analysis (I, II).....	40
4.4	Splicing analysis (I).....	41
4.5	Haplotype analysis (I, II).....	41
4.6	Gene-expression and mRNA analysis (IV).....	41
4.7	<i>In silico</i> prediction tools and online databases (I, II, IV).....	42
4.8	Statistical methods (I, II, IV).....	42
4.9	Ethical aspects.....	42
5	Results.....	43
5.1	Identification of <i>RAD51C</i> and <i>RAD51D</i> mutations (I, II).....	43
5.2	Frequencies of <i>RAD51C</i> and <i>RAD51D</i> point mutations (I, II, III).....	43
5.2.1	Truncating <i>RAD51C</i> and <i>RAD51D</i> mutations (I, II, III).....	43
5.2.2	<i>RAD51C</i> c.790G>A missense variant (I).....	46
5.3	Effects of the <i>RAD51C</i> and <i>RAD51D</i> splicing mutations (I, II).....	47
5.4	<i>RAD51C</i> and <i>RAD51D</i> families and haplotype analysis (I, II).....	48
5.5	Clinical characteristics of <i>RAD51C</i> and <i>RAD51D</i> mutation carriers (I, II).....	50
5.6	Gene-panel sequencing (IV).....	52
5.6.1	Mutations identified in gene-panel sequencing.....	52
5.6.2	Genotyping of the <i>RAD51C</i> duplication.....	54
5.6.3	<i>RAD51C</i> expression.....	56
6	Discussion.....	58
6.1	Germline mutations in <i>RAD51C</i> and <i>RAD51D</i> increase ovarian cancer risk.....	58
6.2	<i>RAD51C</i> and <i>RAD51D</i> mutations in breast cancer predisposition.....	60
6.3	<i>RAD51C</i> and <i>RAD51D</i> mutation carrier families and ovarian tumors.....	61
6.4	<i>RAD51C</i> and <i>RAD51D</i> in prostate and colorectal cancer predisposition.....	63
6.5	Gene-panel testing identifies mutations in various genes.....	63
6.6	CNVs identified in the gene-panel study.....	65
6.7	Prevalence of <i>RAD51C</i> and <i>RAD51D</i> mutations.....	66
7	Summary and conclusions.....	68
	Acknowledgements.....	71
	References.....	73

# LIST OF ORIGINAL PUBLICATIONS

This thesis is based on the following publications:

I Pelttari LM, Heikkinen T, Thompson D, Kallioniemi A, Schleutker J, Holli K, Blomqvist C, Aittomäki K, Bützow R, Nevanlinna H. RAD51C is a susceptibility gene for ovarian cancer. *Hum Mol Genet.* 2011; 20:3278-3288. doi: 10.1093/hmg/ddr229.

II Pelttari LM, Kiiski J, Nurminen R, Kallioniemi A, Schleutker J, Gylfe A, Aaltonen LA, Leminen A, Heikkilä P, Blomqvist C, Bützow R, Aittomäki K, Nevanlinna H. A Finnish founder mutation in RAD51D: analysis in breast, ovarian, prostate, and colorectal cancer. *J Med Genet.* 2012; 49:429-432. doi: 10.1136/jmedgenet-2012-100852.

III Pelttari LM, Nurminen R, Gylfe A, Aaltonen LA, Schleutker J, Nevanlinna H. Screening of Finnish RAD51C founder mutations in prostate and colorectal cancer patients. *BMC Cancer.* 2012; 12:552. doi: 10.1186/1471-2407-12-552.

IV Pelttari LM, Shimelis H, Toiminen H, Kvist A, Törngren T, Borg Å, Blomqvist C, Bützow R, Couch F, Aittomäki K, Nevanlinna H. Gene-panel testing of breast and ovarian cancer patients identifies a recurrent *RAD51C* duplication. *Clin Genet.* 2018; 93:595-602. doi: 10.1111/cge.13123.

The publications are referred to in the text by their Roman numerals.

# ABBREVIATIONS

<i>ACTB</i>	actin beta
<i>ARID1A</i>	AT-rich interaction domain 1A
BLM	Bloom syndrome RecQ like helicase
<i>BMPR1A</i>	bone morphogenetic protein receptor type 1A
bp	base pair
<i>BRIP1</i>	BRCA1 interacting protein C-terminal helicase 1
<i>CDH1</i>	cadherin 1
<i>CHEK2</i>	checkpoint kinase 2
CI	confidence interval
CNV	copy number variant
DSB	double-strand break
ER	estrogen receptor
ERBB2	erb-b2 receptor tyrosine kinase 2
ESP	NHLBI GO Exome Sequencing Project
ExAC	Exome Aggregation Consortium
FA	Fanconi anemia
<i>FANCC/D1/J/M/N/O/S</i>	Fanconi anemia complementation group C/D1/ J/M/N/O/S
gnomAD	Genome Aggregation Database
GWAS	genome-wide association study
HER2	human epidermal growth factor receptor 2
HGSC	high-grade serous carcinoma
<i>HOXB13</i>	homeobox B13
HR	homologous recombination
ICL	interstrand crosslink
IHC	immunohistochemical
kb	kilobase pair
LFS	Li-Fraumeni syndrome
LGSC	low-grade serous carcinoma
lncRNA	long non-coding RNA
LOH	loss-of-heterozygosity
M	distant metastasis at diagnosis
MAF	minor-allele frequency
miRNA	microRNA
<i>MLH1</i>	mutL homolog 1
MLPA	Multiplex Ligation-dependent Probe Amplification
MMR	mismatch repair
MRN	MRE11/RAD50/NBN complex
mRNA	messenger RNA
<i>MSH2</i>	mutS homolog 2
<i>MSH6</i>	mutS homolog 6
<i>MUTYH</i>	mutY DNA glycosylase

N	lymph node status
<i>NBN</i>	nibrin
<i>NF1</i>	neurofibromin 1
NGS	next-generation sequencing
NHEJ	non-homologous end-joining
OR	odds ratio
<i>PALB2</i>	partner and localizer of BRCA2
PARP	poly(ADP-ribose) polymerase
PCR	polymerase chain reaction
PHTS	<i>PTEN</i> hamartoma tumor syndrome
PJS	Peutz–Jeghers syndrome
<i>POLD1</i>	DNA polymerase delta 1, catalytic subunit
<i>POLE</i>	DNA polymerase epsilon, catalytic subunit
PR	progesterone receptor
PRS	polygenic risk score
<i>PTEN</i>	phosphatase and tensin homolog
<i>RAD51B</i>	RAD51 paralogue B
<i>RAD51C</i>	RAD51 paralogue C
<i>RAD51D</i>	RAD51 paralogue D
<i>RAD54L</i>	RAD54 like
<i>RB1</i>	RB transcriptional corepressor 1
RQ	relative quantification
RR	relative risk
SEM	standard error of the mean
<i>SMAD4</i>	SMAD family member 4
SNP	single-nucleotide polymorphism
STIC	serous tubal intraepithelial carcinoma
<i>STK11</i>	serine/threonine kinase 11
T	tumor size
TNBC	triple-negative breast cancer
<i>TP53</i>	tumor protein p53
<i>XRCC2</i>	X-ray repair cross complementing 2
<i>XRCC3</i>	X-ray repair cross complementing 3

## ABSTRACT

Breast and ovarian cancers are common cancers affecting women. Family history of the disease is a major risk factor for both cancers. Even though several susceptibility alleles have been identified, genetic predisposition to breast and ovarian cancer is still largely unexplained. The majority of the known risk-genes, most importantly *BRCA1* and *BRCA2*, play a role in DNA damage repair and especially in homologous recombination repair. Important players in homologous recombination are the *RAD51* paralog genes *RAD51C* and *RAD51D*, in which rare mutations have been identified in breast and ovarian cancer families. *RAD54L* is another gene involved in homologous recombination and is thus a putative candidate susceptibility gene. With the growing number of identified risk-genes and the development of efficient next-generation sequencing methods, multigene-panels have now largely replaced traditional *BRCA1* and *BRCA2* testing in clinical genetic testing of breast and ovarian cancer patients.

The aim of this study was to identify pathogenic germline mutations in the *RAD51C*, *RAD51D*, and *RAD54L* genes in breast and ovarian cancer families and to evaluate the association of the identified mutations with breast, ovarian, prostate, and colorectal cancer risk in the Finnish population. In addition, 95 high-risk breast or ovarian cancer patients were investigated with a gene panel to study the mutation spectrum of 10 known susceptibility genes and to identify new mutations.

The *RAD51C* gene was sequenced in 277 and the *RAD51D* and *RAD54L* genes in 95 familial breast or ovarian cancer patients. Two protein-truncating mutations in *RAD51C*, c.93delG and c.837+1G>A, and one in *RAD51D*, c.576+1G>A, were identified and subsequently genotyped in breast (n ≈ 2000), ovarian (n ≈ 500), prostate (n ≈ 1000) and colorectal (n ≈ 1000) cancer patients and population controls (n ≈ 2000). Mutations in both genes were enriched in ovarian cancer patients. The *RAD51C* mutations were significantly more frequent in familial and unselected ovarian cancer patients and the *RAD51D* mutation in breast-ovarian cancer families than in population controls. The mutation frequency in both genes was also significantly increased among patients with a personal or family history of ovarian cancer, but did not significantly differ between unselected breast cancer patients and population controls. No mutations were observed in prostate or colorectal cancer patients. These results suggest that germline mutations in *RAD51C* and *RAD51D* increase the risk of ovarian cancer, but not breast, prostate, or colorectal cancer risk.

The gene-panel testing identified 12 different pathogenic mutations in 18 of the 95 patients (19%), including two patients with two different protein-truncating mutations. *BRCA1* or *BRCA2* mutations, including one genomic duplication in *BRCA1*, were identified in 8 patients (8.4%) and mutations in other genes in 10 patients (10.5%). The most commonly mutated gene was *CHEK2*,



whereas single mutations were observed in *TP53*, *PTEN*, and *RAD51C*. In addition, a novel duplication covering the *RAD51C* exons 1–7 was identified. Together, the *BRCA1* duplication and the novel *RAD51C* duplication accounted for approximately 10% of all the observed pathogenic or potentially pathogenic mutations. Genotyping of the duplication in breast ( $n \approx 2500$ ) and ovarian ( $n \approx 500$ ) cancer patients and population controls ( $n \approx 1000$ ) revealed seven carriers among the cases, but none among the controls and a significant association with ovarian cancer risk.

This thesis study establishes *RAD51C* as an ovarian cancer susceptibility gene, presents information that strengthens the role of *RAD51D* mutations in ovarian cancer predisposition, and provides valuable new knowledge on the associated cancer risks for both genes. The results also highlight the importance of comprehensive mutation testing of all the relevant susceptibility genes in the clinical genetic testing of breast and ovarian cancer patients.

# 1 INTRODUCTION

Breast cancer is the most common cancer among women worldwide and ovarian cancer ranks seventh <sup>1</sup>. Despite having a good prognosis, breast cancer is the leading cause of female cancer deaths. The prognosis for ovarian cancer is substantially worse, it being the deadliest gynecological cancer. One of the strongest risk factors for breast and ovarian cancer is a positive family history. First-degree relatives of breast and ovarian cancer patients are at an approximately two and three-fold increased risk, respectively, compared to the general population. Several susceptibility genes have been identified, with most of them working in DNA damage response and repair pathways <sup>2</sup>. Germline mutations in these genes increase the risk of breast or ovarian cancer or both. The pathogenic mutations are most commonly protein-truncating, but some pathogenic missenses have been recognized while large genomic deletions and duplications can also disrupt the genes. Mutations in high and moderate-risk genes are rare in the general population but when they do occur they significantly increase the cancer risk of the individual. The most important susceptibility genes are *BRCA1* and *BRCA2*, which confer a high lifetime risk of both breast and ovarian cancer. Mutations in *BRCA2* are also associated with an increased risk of prostate cancer. In addition, numerous common susceptibility alleles for breast and ovarian cancer predisposition have been identified that confer a lower increase in cancer risk. They contribute to the cancer burden at the population level and modify the cancer risk in women with inherited high or moderate-risk mutations. In the isolated Finnish population, the majority of pathogenic mutations in the susceptibility genes are accounted for by a few recurrent founder mutations.

Clinical genetic testing of high-risk breast and ovarian cancer patients was long restricted to the *BRCA1* and *BRCA2* genes, but with the development of next-generation sequencing (NGS) methods and the large number of identified susceptibility genes, gene panels are now increasingly utilized <sup>3</sup>. This has allowed many more women to receive a genetic diagnosis and is valuable for families where more than one risk allele is segregating. However, it is still the case that often only *BRCA1* and *BRCA2* may be analyzed for large genomic changes. To provide accurate counseling for families with inherited mutations and to determine the degree of the associated risk, much more research is warranted for the genes included in these panels.

This thesis study examined the association of *RAD51C* and *RAD51D* germline mutations with breast, ovarian, prostate, and colorectal cancer risk, as well as the role of the *RAD54L* gene in breast and ovarian cancer predisposition. The mutation spectrum of 10 established susceptibility genes among high-risk breast and ovarian cancer patients was studied with a gene panel.

## 2 REVIEW OF THE LITERATURE

Cancer is the most common cause of death both in the developed and less developed countries <sup>1</sup>. Worldwide, 14.1 million new cancer cases and 8.2 million cancer deaths were estimated to have occurred in 2012. In Finland, almost 33 000 new cancer cases were diagnosed in 2015 and more than 12 000 people died of cancer <sup>4</sup>. The most common causes of cancer death in Finland were lung cancer for men and breast cancer for women.

### 2.1 BIOLOGY OF CANCER

Cancer is a genetic disease involving uncontrolled cell proliferation. Tumorigenesis is a multistep process through which normal cells are transformed into malignant cells that form tumors. To become cancerous, cells need to acquire several biological capabilities – the hallmarks of cancer: self-sufficient growth signaling, insensitivity to antigrowth signals, apoptosis resistance, limitless replication, sustained angiogenesis, and tissue invasion and metastasis, as well as the two emerging hallmarks of reprogramming of energy metabolism and escaping immune destruction <sup>5, 6</sup>. In addition, two enabling characteristics, genomic instability and inflammation, facilitate the acquisition of these traits. The proliferation of normal cells is strictly regulated whereas the acquired self-sufficiency of growth signals, insensitivity to growth-inhibitory signals, evasion of apoptosis, and replicative immortality enable continued proliferation of cancer cells <sup>5</sup>. The acquired ability to induce and sustain angiogenesis – the growth of new blood vessels – provides nutrients and oxygen for the tumor. The ability to invade adjacent tissues and to send distant metastases enables cancer cells to escape the primary tumor mass to a different site in the body with more nutrients and space to grow. The emerging hallmark of reprogramming of energy metabolism supports the continuous cell growth and proliferation, whereas the second emerging hallmark gives the tumor cells the ability to avoid elimination by immune cells <sup>6</sup>. Genomic instability, which generates genetic alterations, and tumor-promoting inflammation, which may supply growth-promoting or other bioactive molecules or release mutagenic agents, enable the cells to acquire these capabilities and to become malignant <sup>5, 6</sup>. The increased mutation rate generated by genomic instability may be a consequence of an increased sensitivity to external mutagens, the loss of telomeric DNA, or defective genome maintenance, caused by, for example, mutated caretaker genes that detect and repair DNA damage.

Tumors display remarkable heterogeneity; they are composed of a mixture of cancer cells and various infiltrating normal cell types, which form the tumor microenvironment <sup>6, 7</sup>. According to the cancer stem-cell model, only subpopulations of tumor cells – the self-renewing cancer stem cells – can initiate

and sustain tumor growth <sup>7</sup>. Recruited normal cells, including endothelial cells, pericytes, immune inflammatory cells, and cancer-associated fibroblasts, form the tumor microenvironment, which creates much of the cellular heterogeneity of tumors <sup>6</sup>. The tumor microenvironment plays an important role in tumorigenesis and evolves during the tumor progression.

Tumors arise from a single cell of origin and evolve through clonal expansion <sup>8</sup>. Tumor progression is driven by sequential acquisition of somatic mutations that provide selective growth advantage for the cell in which they arise. Mutations in the cells occur relatively randomly. Errors may occur during DNA replication, and DNA damage can also be caused by external mutagens, such as tobacco smoke and ultraviolet light. If the DNA damage is not repaired, these changes will be fixed into mutations that are present in all the cell offspring <sup>9</sup>. The individual progenitor cell with a growth advantage over its neighbors will be positively selected. Additional advantageous mutations in some of the offspring cells will give rise to new subpopulations with a further growth advantage. Many cells with deleterious mutations are eliminated by natural selection, whereas cells carrying alterations that confer the capability to proliferate and survive more effectively than others are favored and continue to expand <sup>8</sup>.

Cancer cells harbor large numbers of acquired somatic mutations, such as base substitutions, small insertions or deletions, and large rearrangements, as well as epigenetic changes <sup>9</sup>. Mutations in cancer genomes can be divided into causal “driver” mutations and neutral “passenger” mutations <sup>9, 10</sup>. Driver mutations in cancer genes give growth advantage for the cell and are positively selected, whereas passenger mutations do not confer selective growth advantage and may occur in any gene. A clear majority of somatic mutations in a cancer genome are passengers that are carried to descendent cell clones, but do not contribute to tumorigenesis <sup>9-11</sup>.

### **2.1.1 DNA DAMAGE REPAIR**

The DNA damage response network protects cells from detrimental effects of DNA damage <sup>12</sup>. Checkpoints during the cell cycle ensure that the damage is recognized and appropriately repaired before the cell proceeds to proliferate. Unrepaired DNA damage can lead to genomic instability – a hallmark of cancer – including chromosome breaks, translocations, rearrangements, gene amplifications, and deletions. Protein kinases in the DNA damage signaling networks and cell cycle checkpoints recognize the damage, delay cell cycle progression and recruit and activate repair proteins. If the damage cannot be repaired, the DNA damage signaling proteins trigger apoptosis or cellular senescence.

Various distinct repair mechanisms have evolved to fix different types of DNA damage <sup>12, 13</sup>. Small base lesions caused by oxidation, deamination, and alkylation are repaired with base excision repair. Helix-distorting base lesions, such as DNA damage caused by ultraviolet light, can be repaired via nucleotide excision repair. Base-base mismatches and insertion/deletion loops can occur during DNA

replication and recombination, and they are repaired via mismatch repair (MMR), which takes place immediately after replication. One of the most severe forms of DNA damage is DNA double-strand breaks (DSBs). They can arise endogenously during replication or from exogenous exposure to radiation or other DNA-damaging agents. They are preferentially repaired via error-free homologous recombination (HR), whereas non-homologous end-joining (NHEJ) is a more error-prone mechanism<sup>12-14</sup>. HR takes place in the S and G2 phases of the cell cycle when the homologous sister chromatid is available to use as a template to ensure accurate repair. In contrast, NHEJ operates throughout the cell cycle and can introduce errors as it directly ligates the two ends of broken DNA together. Interstrand crosslinks (ICLs) are another highly toxic type of lesion which may be caused by environmental mutagens and many chemotherapeutic drugs as well as by endogenous products, such as aldehydes and nitrous acid<sup>12, 15</sup>. Their repair requires interplay between the Fanconi anemia (FA) pathway and several other repair mechanisms, including nucleotide excision repair, MMR, HR, NHEJ, and translesion synthesis. In addition to ICL repair, the FA pathway also stabilizes stalled replication forks.

## 2.2 CANCER GENES

Over 200 genes have been recognized to act as driver genes in human cancer, and many more are likely to be discovered<sup>10,16</sup>. Alterations in these genes contribute to cancer development through the stimulation of cell proliferation or the inhibition of cell death or of cell cycle arrest. However, a single mutated gene is not enough to cause cancer but several genes need to be altered for an invasive cancer to develop<sup>17</sup>.

Cancer genes can be broadly classified into dominantly acting oncogenes and recessive tumor suppressor genes<sup>17, 18</sup>. Oncogenes encode proteins that control cell proliferation or apoptosis, such as transcription factors, growth factors, or apoptosis inhibitors<sup>17, 19</sup>. In cancer, they are activated via gain-of-function mutations, which make the gene constitutively active or active under conditions when the gene would normally be inactive. They can be activated by recurrent missense mutations affecting specific residues, by chromosomal translocations, or by gene amplifications. For example, the *BRAF* oncogene, which encodes a serine/threonine kinase, is somatically mutated in a wide variety of cancers, most frequently in melanoma<sup>16, 20</sup>. The majority of the mutations are missense mutations, affecting a single amino acid in the kinase domain<sup>20</sup>.

In contrast, tumor suppressor genes are disrupted by loss-of-function mutations<sup>17, 18</sup>. The inactivating mutations are typically protein-truncating mutations, while missense mutations affecting essential residues and epigenetic silencing can also inactivate tumor suppressor genes. Generally, both alleles of the tumor suppressor need to be inactivated for it to contribute to cancer development. However, some tumor suppressors may display

haploinsufficiency, i.e. where loss of only one copy of the gene is enough to drive tumorigenesis.

Tumor suppressors can be further categorized into gatekeepers and caretakers<sup>17, 18</sup>. Gatekeepers are traditional tumor suppressors that directly affect cellular proliferation by inhibiting growth or by promoting death<sup>18</sup>. A classic example is the first characterized tumor suppressor, *RB1*, which controls the cell cycle and is mutated in retinoblastoma<sup>21, 22</sup>. Caretakers, sometimes categorized separately as stability genes, maintain genomic stability<sup>17, 18</sup>. They encode proteins that function in DNA repair, such as the breast cancer genes *BRCA1* and *BRCA2* involved in HR. Inactivating mutation in a caretaker gene does not directly affect tumor initiation or growth, but leads to an increased mutation rate and thus may activate oncogenes or inactivate gatekeepers.

Another class of genes with an indirect effect on tumorigenesis is landscapers<sup>23</sup>. They act in neighboring stromal cells and contribute to tumorigenesis by creating an abnormal microenvironment for the epithelial cells to grow.

In addition to protein-coding genes, non-coding RNA genes such as microRNAs (miRNAs) and long non-coding RNAs (lncRNAs) can contribute to tumorigenesis<sup>24-26</sup>. miRNAs are small, approximately 20–22 nucleotide long RNAs that are processed from longer precursor RNAs<sup>24, 25</sup>. They regulate the expression of other genes by binding to messenger RNA (mRNA) and thus repress translation. They can function both as oncogenes and tumor suppressors: increased expression of oncogenic miRNAs leads to down-regulation of tumor suppressors, whereas loss of tumor suppressive miRNAs leads to up-regulation of oncogenes. Deregulation of the miRNA gene can result from amplification, deletion, deregulation of a transcription factor, or epigenetic changes. The same miRNA can function as an oncogene in some tissues and as a tumor suppressor in others, depending on its target in the specific tissue. An example of miRNAs involved in tumorigenesis are *miR-15* and *miR-16*, which are frequently deleted or down-regulated in chronic lymphocytic leukemia, and which target the *BCL2* oncogene involved in the inhibition of apoptosis<sup>27, 28</sup>.

lncRNAs are a less well characterized group of heterogeneous RNAs that are longer than 200 nucleotides<sup>26</sup>. Their expression is tissue-specific and regulated, and they are often differentially expressed in tumors. They contribute to tumorigenesis by regulating the expression of other genes via diverse mechanisms, for example, by interacting with the epigenetic machinery to silence genes or through post-transcriptional events such as splicing or post-translational modification of proteins. Like miRNAs, lncRNAs can function as oncogenes or tumor suppressors. Many lncRNAs regulate the expression of the *MYC* oncogene or the *TP53* tumor suppressor, or are their direct transcriptional targets.

## 2.2.1 HEREDITARY PREDISPOSITION TO CANCER

Pathogenic germline mutations in oncogenes and tumor suppressor genes cause hereditary predisposition to cancer<sup>17,18,29</sup>. The majority of cancer predisposing mutations are in tumor suppressor genes, and mutations in caretakers are especially common. For instance, *BRCA1* and *BRCA2* caretaker gene mutations predispose to breast and ovarian cancer<sup>30, 31</sup>. Only a few oncogenes with inherited germline mutations have been recognized<sup>29</sup>. Rare examples are germline mutations in the *RET* oncogene, predisposing to multiple endocrine neoplasia type 2A, and *MET* mutations predisposing to papillary renal carcinoma<sup>32-34</sup>.

Even though many cancer genes, especially caretakers, function in almost every cell of the body, inherited mutations in them usually predispose to specific tumor types in certain tissues<sup>17</sup>. For example, defects in MMR genes predominantly predispose to colorectal cancer and mutations in *BRCA1* and *BRCA2* to breast and ovarian cancer, yet the normal protein products of these genes have ubiquitous roles in DNA repair<sup>17, 30, 31, 35-38</sup>.

The inheritance pattern in cancer susceptibility is mainly autosomal dominant with varying penetrance, even though on the cellular level, tumor suppressor genes act in a recessive manner<sup>29,39</sup>. According to Knudson's "two-hit" model, two independent mutational events are required for tumor development<sup>22,40</sup>. In the hereditary form of cancer, the first mutation is inherited in the germline and the second allele of the tumor suppressor is inactivated somatically. For non-hereditary sporadic cases, both mutations are somatic. Individuals with a germline mutation usually develop cancer at a younger age, and they often develop multiple tumors as only one additional somatic mutation is required to initiate tumorigenesis. However, for most tumors to develop into malignant cancers, additional mutations in other genes are required. Most cancers have inactivated *RB1* or *TP53*, or other genes in the same pathways, which control cell-cycle and apoptosis<sup>17, 22</sup>. Moreover, high-penetrance mutations in tumor suppressor genes are rare in the population and much of the inherited susceptibility to cancer is thought to be polygenic, resulting from multiplicative effects of several co-inherited lower-penetrance variants<sup>39</sup>.

## 2.3 BREAST CANCER

Breast cancer is the most common cancer and the leading cause of cancer deaths among women worldwide, accounting for 25% of all female cancer cases and 15% of female cancer deaths<sup>1</sup>. In developed countries, however, lung cancer has become the leading cause of female cancer mortality. Worldwide, 1.7 million breast cancer cases and half a million deaths were estimated as occurring in 2012. In Finland, 5161 female breast cancer cases were diagnosed in 2015, comprising 32% of all female cancer cases<sup>4</sup>. The lifetime risk of breast cancer for a Finnish woman is over 10%. Breast cancer is the leading cause of cancer deaths for women in Finland also, with 841 deaths observed in 2015, accounting for

15% of all female cancer mortality. Male breast cancer, however, is a rare disease, though the incidence has been increasing. On average, approximately 20 male breast cancer cases are diagnosed in Finland annually.

Despite the large numbers of breast cancer deaths, the prognosis is generally good; Finland has one of the top survival rates among European countries, with an over 90% 5-year relative survival ratio <sup>4,41</sup>. Over the past decades, the breast cancer incidence rate has been increasing worldwide, whereas the mortality rate has been decreasing in developed countries <sup>1, 4, 42</sup>. In more recent decades, however, declining or stable incidence rates have been seen in many Western countries, although not in Finland <sup>1,4</sup>. These changes in the incidence rates are mainly due to changes in reproductive factors, use of postmenopausal hormone replacement therapy, and increased mammographic screening <sup>1,42</sup>. Decreased use of hormone therapy as well as plateau reached in screening participation probably account for the recent decline in incidence. Early detection due to the increased screening has reduced mortality along with improved treatment <sup>1,42,43</sup>.

### **2.3.1 BREAST CANCER CLASSIFICATION AND SUBTYPES**

The female breast consists of lobules – the functional milk-producing units – and milk ducts, as well as surrounding fat and connective tissue <sup>44</sup>. Breast carcinomas originate from the epithelial cells lining the terminal duct lobular unit. Invasive carcinomas have spread outside the basement membrane of the ducts and lobules into the normal tissue, whereas *in situ* tumors remain within the basement membrane.

Breast cancer is a very heterogeneous disease with over 20 different histological types recognized by the WHO <sup>45</sup>. Most breast cancers are invasive ductal carcinomas of no special type; these account for up to 75% of all invasive breast carcinomas. Special types of breast cancer include classical lobular carcinoma, which is the second most common subtype, comprising up to 15% of all invasive carcinomas, and several rare subtypes, such as medullary, mucinous, and tubular carcinomas <sup>45, 46</sup>. The different subtypes vary in their morphology and clinical outcome.

Breast cancers can be classified according to grade, stage, and immunohistochemical (IHC) score, which are classical predictors of prognosis that guide the selection of treatment options <sup>45, 47, 48</sup>. The histological grading is based on the degree of differentiation of the tumor tissue and is defined by three morphological features: tubule formation, nuclear pleomorphism, and mitotic count <sup>47, 49</sup>. It ranges from more differentiated grade I tumors with a good prognosis to poorly differentiated grade III tumors with a worse prognosis. The TNM staging system is based on the primary tumor size (T), the status of the regional lymph nodes (N), and the presence of distant metastases at diagnosis (M) <sup>50</sup>. IHC staining of estrogen receptor (ER), progesterone receptor (PR), Ki67 proliferation marker, and HER2 (also known as ERBB2) expression can be used to broadly classify breast cancers <sup>48</sup>.



Gene-expression profiling allows more detailed classification of breast cancers into four intrinsic molecular subtypes: luminal A and B, basal-like or triple-negative, and HER2-positive (HER2+) cancers (Table 1) <sup>51-53</sup>. Ductal and lobular carcinomas can fall into any of these molecular subtypes, whereas the rare special histological types typically represent only one molecular subtype <sup>46</sup>. For instance, tubular and mucinous carcinomas with a good prognosis are usually of the luminal A subtype whereas medullary cancers are triple-negative.

Luminal cancer cells resemble the inner luminal, while basal-like cancer cells resemble the outer basal epithelial cells of the milk ducts, and the two can be distinguished by the IHC staining of cytokeratins 8/18 and 5/6, respectively <sup>51</sup>. Luminal cancers have a better prognosis than basal-like or HER2+ cancers (Table 1) <sup>45, 52-55</sup>. The most common subtype is Luminal A, which also has the best prognosis. Luminal B tumors are larger and more poorly differentiated than luminal A tumors. Somatic *TP53* mutations, which are associated with poor prognosis, are found only in a minority of luminal A tumors, whereas they are more common in luminal B tumors and found in a majority of basal-like and HER2+ tumors. As luminal cancers usually express ER, they can be treated with endocrine therapy. Treatment of basal-like carcinomas is mainly limited to chemotherapy as they are typically triple-negative, i.e. negative for ER, PR, and HER2. HER2+ cancers overexpress HER2, usually through DNA amplification of the *HER2* locus, and thus can be treated with anti-HER2 agents.

**Table 1.** *Characteristics of the intrinsic molecular subtypes of breast cancer*

Subtype	Typical IHC pattern	<i>TP53</i> mutations	Prognosis
Luminal A	ER and/or PR positive HER2 negative low Ki67	Rare	Good
Luminal B	ER and/or PR positive HER2 positive or negative high Ki67	Common	Intermediate
Basal-like	ER, PR and HER2 negative	Majority	Poor
HER2+	ER and PR negative HER2 positive	Majority	Poor (without anti-HER2 therapy)

Even more refined clustering into ten integrative clusters (IntClust 1–10) can be achieved by combining gene-expression with copy-number analysis <sup>55,56</sup>. Tumors in different clusters have distinct genomic alterations and clinical outcomes and the intrinsic molecular subtypes are split between many clusters (Table 2).

**Table 2.** Characteristics of the breast cancer integrative clusters (Russness et al. 2017)

IntClust	Copy number driver	Typical IHC class	Dominant intrinsic subtype	Prognosis
1	Chr17/Chr20	ER pos	Luminal B	Intermediate
2	Chr11	ER pos	Luminal A and B	Poor
3	Very few	ER pos	Luminal A	Good
4	Very few	ER pos or neg	Luminal A (mixed)	Good
5	Chr17 (HER2 locus)	ER pos or neg, HER2 pos	Luminal B and HER2+	Very poor (without anti-HER2 therapy)
6	Chr8	ER pos	Luminal B	Intermediate
7	Chr16	ER pos	Luminal A	Good
8	Chr1/Chr16	ER pos	Luminal A	Good
9	Chr8/Chr20	ER pos	Luminal B (mixed)	Intermediate
10	Chr5/Chr8/Chr10/Chr12	TNBC	Basal-like	Poor 5-year, good long-term

Chr = chromosome, pos = positive, neg = negative

### 2.3.2 BREAST CANCER RISK FACTORS

As is typical for most cancers, breast cancer incidence increases with age, making age one of its strongest risk factors <sup>22, 57</sup>. Other well-established risk factors include reproductive and hormonal factors such as early menarche, late menopause, low parity, and older age at first birth <sup>57</sup>. Breastfeeding has been shown to decrease the risk of breast cancer <sup>58</sup>. Long-term postmenopausal hormone therapy with combined estrogen and progestogen increases breast cancer risk, whereas the contribution of oral contraceptives is unclear, with a modest increase in risk at most <sup>59,60</sup>. Some lifestyle-related factors, such as excess body weight, alcohol consumption, and physical inactivity, increase the risk <sup>57,61-63</sup>. Recent studies indicate that smoking is also associated with breast cancer risk and mortality <sup>64,65</sup>.

Even though environmental and lifestyle factors account for majority of the breast cancer cases, genetic predisposition is also an important risk factor <sup>57</sup>. Family history of the disease increases breast cancer risk significantly; however, most breast cancer patients do not have family history and most female relatives of breast cancer patients do not develop the disease <sup>66,67</sup>. First-degree relatives of breast cancer patients are estimated to have an approximately two-fold risk and the risk increases with increasing number of affected relatives as well as with younger affected relatives. The genes as well as the environmental and lifestyle factors shared between family members contribute to the familial aggregation of the disease <sup>57</sup>. The heritability of breast cancer – the proportion of the variation

in risk in a population attributable to genetic differences between individuals – is estimated to be 31%, whereas common environmental factors are estimated to explain 16% of the variability<sup>68</sup>. The heritability estimate includes variation in susceptibility genes that directly affect breast cancer risk as well as genetic variation that contributes to breast cancer risk factors such as obesity. High-risk mutations, such as in *BRCA1* and *BRCA2*, are rare in the general population, but they increase the risk of individuals remarkably<sup>69,70</sup>. On the other hand, lower-risk variants are more common in the population but their contribution to breast cancer predisposition at the level of the individual is modest.

## **2.4 OVARIAN CANCER**

Ovarian cancer is the 7<sup>th</sup> most common cancer and the 8<sup>th</sup> most common cause of cancer deaths among women worldwide, with 238 700 cases and 151 900 deaths estimated to have occurred in 2012 alone<sup>1</sup>. In Finland, 436 women were diagnosed with ovarian cancer in 2015, comprising 2.7% of all female cancer cases and making ovarian cancer the 11<sup>th</sup> most common cancer among the women<sup>4</sup>. In female cancer mortality, however, ovarian cancer ranks 5<sup>th</sup> in Finland, with 349 deaths observed in 2015. The lifetime risk of ovarian cancer for a Finnish woman is a little over 1%. The prognosis for ovarian cancer is markedly worse than for breast cancer, and it is the most lethal gynecologic cancer; the 5-year relative survival ratio in Finland is 43%<sup>4</sup>. A decline in the ovarian cancer incidence rate has been observed in the past decades, but very little improvement is seen in the survival rates<sup>41,71</sup>. These rates likely reflect the use of oral contraceptives, which decreases the risk of ovarian cancer, but also the lack of improvements in early detection.

### **2.4.1 OVARIAN CANCER CLASSIFICATION AND SUBTYPES**

Ovarian cancer is an even more heterogeneous disease than breast cancer. Approximately 90% of ovarian cancers are carcinomas originating from epithelial cells, and a small minority are germ cell tumors and sex cord-stromal tumors<sup>72</sup>.

Ovarian carcinomas can be divided into two distinct categories: type I and type II tumors (Table 3)<sup>73,74</sup>. Type I tumors are less frequent and are often diagnosed at an early stage when they are confined to the ovaries. Type II tumors account for the majority of ovarian cancers and they are usually diagnosed at an advanced stage as they are very aggressive and evolve rapidly. While type I tumors have relatively good prognosis, type II tumors have very poor prognosis, accounting for 90% of ovarian cancer deaths.

Several different histologic types have been recognized and according to the 2014 WHO classification, invasive ovarian carcinomas can be classified into low and high-grade serous, mucinous, seromucinous, endometrioid, clear cell, and undifferentiated carcinomas, and malignant Brenner tumors<sup>75</sup>. Low-grade

serous (LGSC), endometrioid, clear cell, seromucinous, and mucinous carcinomas as well as Brenner tumors are included in type I tumors (Table 3)<sup>74</sup>. Even though type I tumors represent distinct histologic subtypes, they all progress in a similar stepwise manner from benign cystic neoplasms to intermediate borderline tumors and finally to invasive cancers. They are relatively stable genetically and do not usually harbor somatic *TP53* mutations. Specific mutational patterns are found in different histotypes, for instance, *KRAS* and *BRAF* mutations are often observed in LGSCs and mucinous tumors, while *ARID1A*, *PTEN*, and *PIK3CA* mutations are typical for endometrioid and clear cell tumors.

**Table 3.** Type I and type II ovarian carcinomas

Histotype	Tissue of origin	Molecular features	Clinicopathological features
<b>Type I</b>			
LGSC	Fallopian tube	Genetically stable, somatic <i>TP53</i> mutations rare	Early stage, low grade, relatively good prognosis
Endometrioid carcinoma	Endometriosis		
Clear cell carcinoma			
Seromucinous carcinoma			
Mucinous carcinoma	Tuboperitoneal junction		
Brenner tumors	Tuboperitoneal junction		
<b>Type II</b>			
HGSC	Fallopian tube	High chromosomal instability, frequent <i>TP53</i> mutations	Advanced stage, high grade, aggressive, poor prognosis
Carcinosarcoma	Fallopian tube		
Undifferentiated carcinoma	Possibly fallopian tube	Unknown	

The majority of type II tumors – and of all ovarian cancers – are high-grade serous carcinomas (HGSCs)<sup>74</sup>. Serous ovarian carcinomas were formerly graded on a continuous scale from grade 1 to grade 3, but are now divided into low and high-grade carcinomas corresponding to type I and type II tumors, respectively<sup>75</sup>. The former grade 2 serous tumors with wild type *TP53* are now classified as low-grade, and the ones with aberrant *TP53* immunostaining are classified as high-grade<sup>75,76</sup>. Based on gene-expression, HGSCs can be further clustered into four molecular subtypes – immunoreactive, differentiated, proliferative, and mesenchymal – with different clinical outcomes<sup>74,77</sup>. Other less common and less-well characterized type II tumors include undifferentiated carcinomas, and carcinosarcomas that are composed of carcinoma and sarcoma (Table 3)<sup>74</sup>. Type II tumors are morphologically more homogeneous than type I tumors and have a different mutational spectrum. High frequency of somatic *TP53* mutations, chromosomal instability, which leads to widespread copy-number alterations,

and defective homologous recombination repair are typical features of HGSCs. *BRCA1* and *BRCA2* mutations, both germline and somatic, are often observed in HGSCs.

The current view is that ovarian carcinomas largely originate from tissues outside of the ovaries, with serous tumors mainly arising from the distal fallopian tubes, endometrioid, clear cell, and seromucinous tumors from endometriosis, and mucinous and Brenner tumors possibly from transitional epithelium at the tuboperitoneal junction (a site adjacent to the fallopian tubes and ovaries) (Table 3) <sup>74</sup>. Even though all HGSCs may not originate from the fallopian tubes, serous tubal intraepithelial carcinoma (STIC) has been identified as a precursor lesion in a large portion of them, especially in patients with *BRCA1/2* mutations <sup>78, 79</sup>. The tumor-suppressive microenvironment of the fallopian tubes and the more hospitable ovarian microenvironment may explain why carcinomas develop predominantly in the ovaries rather than in the fallopian tubes <sup>80</sup>.

Regardless of their cellular origin, all ovarian, fallopian tube, and peritoneal cancers are staged together under the FIGO classification system – from Stage I tumors confined to ovaries or fallopian tubes to the most advanced Stage IV tumors with distant metastases <sup>72</sup>. Stage and histologic type are major factors affecting the prognosis of patients and guiding the treatment options.

## **2.4.2 OVARIAN CANCER RISK FACTORS AND PREVENTION STRATEGIES**

Similar to breast cancer, the major factors affecting ovarian cancer risk are reproductive and hormonal factors. Parity is a major protective factor and breastfeeding also decreases the risk <sup>81</sup>. Another strong protective factor is the use of oral contraceptives, whereas hormone-replacement therapy may increase the risk slightly although the association is less clear <sup>59, 60, 81-83</sup>. Studies on ovarian cancer risk and age at menarche and menopause have been somewhat inconsistent, but the results of a meta-analysis and a large cohort study indicated an inverse association for age at menarche and a positive association for age at menopause <sup>81, 84, 85</sup>. Polycystic ovarian syndrome is also a known risk factor <sup>81</sup>. Environmental or lifestyle factors that may increase the risk of ovarian cancer include obesity <sup>86-88</sup> and smoking <sup>89, 90</sup> but their effect is rather modest.

There is substantial variation in risk factors between different subtypes, and most of the established risk factors have weaker associations with the most common serous subtype <sup>91</sup>. In a recent large prospective study, parity had the strongest association with endometrioid and clear cell carcinomas, while age at menopause was significantly associated only with these subtypes <sup>91</sup>. However, most of the hormonal and reproductive risk factors were also associated with an overall ovarian cancer risk. Consistent with the endometriotic origin of clear cell and endometrioid ovarian carcinomas, endometriosis is a risk factor for these subtypes and also for LGSC <sup>91, 92</sup>. Of life-style factors, smoking increases the risk of mucinous ovarian cancer but has very little effect on the overall ovarian cancer

incidence<sup>89-91</sup>, and obesity increases the risk of the rarer subtypes but not the common HGSC<sup>87</sup>.

Family history of the disease is a significant risk factor for ovarian cancer<sup>93,94</sup>. First-degree relatives of ovarian cancer patients are estimated to have approximately three times greater risk of ovarian cancer than women in the general population, and the risk is even higher for relatives of younger patients. The heritability of ovarian cancer is estimated to be 39%<sup>68</sup>. *BRCA1* and *BRCA2* mutations are estimated to account for approximately 25% of the familial relative risk of ovarian cancer among first-degree relatives<sup>94</sup>. While first-degree relatives of ovarian cancer patients who are *BRCA1/2*-negative also have a significantly elevated risk, relatives of carriers of *BRCA1/2* mutations have a significantly higher risk.

As ovarian cancers are often diagnosed at an advanced stage, improved methods for prevention and early detection are warranted. The effect of ovarian cancer screening with transvaginal ultrasound and serum CA-125 testing on ovarian cancer mortality has been studied in clinical trials, but significant survival benefit has not been observed<sup>95,96</sup>. Thus, primary prevention may be a more promising strategy. The risk of ovarian cancer can be reduced with oral contraceptives and bilateral salpingectomy, whereas tubal ligation only reduces the risk of endometrioid and clear cell subtypes<sup>74, 80, 91</sup>. As the removal of fallopian tubes has no known adverse side-effects, an opportunistic salpingectomy can be performed at the time of other pelvic surgery or instead of tubal ligation, and prophylactic salpingectomy can be offered to women at increased risk of ovarian cancer<sup>74, 80</sup>. Bilateral salpingo-oophorectomy is well-established as the most effective preventive measure traditionally offered for high-risk women with *BRCA1/2* mutations, but it is associated with adverse side-effects such as increased risk of cardiovascular disease<sup>97</sup>. As *BRCA1/2* mutation carriers typically develop HGSCs originating from tubal cells, salpingectomy possibly coupled with delayed oophorectomy might be sufficient and the adverse effects associated with premature surgical menopause could be avoided<sup>74, 80, 97</sup>. However, more research is required before the efficacy and safety of salpingectomy can be determined.

## 2.5 BREAST AND OVARIAN CANCER SUSCEPTIBILITY GENES

Almost all known breast and ovarian cancer susceptibility genes encode tumor suppressors that function in the DNA damage response and repair pathways<sup>2</sup>. The major affected pathway in predisposition to breast and ovarian cancer is HR, but the FA and MMR pathways are also indicated.

The susceptibility genes and risk-variants can be divided into three groups: high-penetrance genes that confer a greater than 4 or 5-fold relative risk, moderate-penetrance genes conferring an approximately 2 to 5-fold risk, and low-penetrance genes or variants generally conferring a lower than 1.5-fold

risk<sup>3, 69</sup>. Pathogenic mainly protein-truncating mutations in the high and moderate-penetrance genes are rare and only these are considered to have clinical significance. The low-penetrance variants are common with typical minor-allele frequencies (MAF) greater than 1% and they usually reside in non-coding regions of the genome. They contribute to cancer burden at the population level, but single variants do not make a significant difference in the cancer risk of an individual. Multiple low-penetrance variants, however, can be combined to stratify women into different risk categories<sup>98</sup>.

Despite the vast amount of research and growing number of identified susceptibility genes and loci, the majority of the genetic predisposition to breast and ovarian cancer remains unexplained<sup>69, 98-100</sup>. Thus, many more genes and susceptibility loci are yet to be discovered.

## **2.5.1 HIGH-PENETRANCE GENES**

### **2.5.1.1 BRCA1 and BRCA2**

The most important susceptibility genes for both breast and ovarian cancer are *BRCA1* and *BRCA2*, which were discovered through family based linkage-studies<sup>2</sup>. The first breast cancer gene identified was *BRCA1* in 1994 shortly followed by the identification of *BRCA2* in 1995<sup>30, 31</sup>. Women with *BRCA1* or *BRCA2* mutations have a high lifetime risk of breast and ovarian cancer (Table 4)<sup>70, 101, 102</sup>. The prevalence of *BRCA1* and *BRCA2* mutations among breast and ovarian cancer families is approximately 25%, but the prevalence varies greatly according to the type of family history as well as between different populations<sup>103</sup>. In Finland, *BRCA1/2* mutations have been observed in 21% of breast and 26% of ovarian cancer families, and in 1.8% and 5.6% of unselected breast and ovarian cancer patients, respectively<sup>104-107</sup>.

The mutation carriers have an approximately 10 to 30-fold increased risk of breast cancer compared to the general population, but the relative risk decreases with age, especially for *BRCA1* carriers<sup>101</sup>. The ovarian cancer risk for *BRCA1* carriers is substantially higher than for *BRCA2* carriers. In a recent large prospective study, women with *BRCA1* mutations were estimated to have a 72% and 44% risk of developing breast and ovarian cancers, respectively, by age 80<sup>70</sup>. For women with *BRCA2* mutations the risk estimates were 69% for breast cancer and 17% for ovarian cancer. As a comparison, the estimated cumulative risks of breast or ovarian cancer by age 80 for a Finnish woman in the general population are 10.8% and 1.12%, respectively<sup>4</sup>. The breast cancer risk for both *BRCA1* and *BRCA2* carriers increases with an increased number of affected family members<sup>70</sup>. For women without a family history, the estimated risks are likely overestimated, as the study cohort was ascertained mainly through cancer genetic clinics and was enriched for women with a strong family history. For men with *BRCA1* or *BRCA2* mutations, the estimated risk of developing breast cancer by age 70 is 1.2% and 6.8%, respectively<sup>108</sup>.

**Table 4.** Estimated cancer risks associated with established breast and ovarian cancer susceptibility genes. For high-penetrance genes, the risks are estimated primarily as absolute risks; for moderate-penetrance genes, as both absolute and relative risks.

Gene	Breast cancer risk	Ovarian cancer risk	References
<b>High-penetrance genes</b>			
<i>BRCA1</i>	72% by age 80	44% by age 80	70
<i>BRCA2</i>	69% by age 80	17% by age 80	70
<i>TP53</i>	85% by age 60	-	109
<i>PTEN</i>	67–85% lifetime risk	-	110
<i>STK11</i>	31–54% by age 60	-	111
<i>CDH1</i>	42% by age 80	-	112
<i>NF1</i>	RR ≈ 6.5–11 for women aged <40 years; 26% by age 80	-	113, 114
<i>MLH1, MSH2, MSH6, and PMS2</i>	-	6–14% lifetime risk	115
<b>Moderate-penetrance genes</b>			
<i>ATM</i>	RR ≈ 3; 27% by age 80	-	3, 116
<i>CHEK2</i>	RR ≈ 2–3; 20% by age 80	-	117, 118
<i>PALB2</i>	RR ≈ 5; 35% by age 70	-	3, 119
<i>BRIP1</i>	-	RR ≈ 3.4–11; 6% by age 80	120
<i>RAD51C</i>	-	RR ≈ 5.9; >9% by age 80	121
<i>RAD51D</i>	-	RR ≈ 6.3; 10% by age 80	122

RR = relative risk

The majority of the breast tumors in *BRCA1* and *BRCA2* mutation carriers are ductal carcinomas; however, medullary tumors are more common among *BRCA1* carriers than among *BRCA2* carriers, whereas lobular tumors are more common among *BRCA2* carriers<sup>123</sup>. The *BRCA1* and *BRCA2* tumors are often high grade, but *BRCA1* tumors are more commonly grade 3 than *BRCA2* tumors. *BRCA1* breast tumors are usually ER-negative or triple-negative, whereas *BRCA2* tumors are typically hormone receptor positive<sup>123-125</sup>. The majority of the ovarian tumors in *BRCA1* and *BRCA2* mutation carriers are HGSCs<sup>74, 123</sup>. Despite the tumor features associated with poor prognosis, the evidence for worse survival among breast cancer patients with germline *BRCA1/2* mutations compared to non-carriers is inconclusive<sup>126</sup>. For ovarian cancer patients with *BRCA1/2* mutations, the short-term survival is better than for non-carriers, but the advantage decreases over time and for *BRCA1* carriers, the long-term survival is worse than for non-carriers<sup>127</sup>.

The main function of *BRCA1* and *BRCA2* is to promote repair of DSBs via HR<sup>2</sup>. Additional roles for *BRCA1* and *BRCA2* in genome maintenance include DNA-



damage checkpoint signaling as well as the protection of DNA replication forks and ICL repair via the FA pathway <sup>2, 15</sup>.

*BRCA1/2*-mutant tumor cells are sensitive to certain drugs, such as mitomycin C, platinum salts, and poly(ADP-ribose) polymerase (PARP) inhibitors, which stall the progression of replication forks <sup>128</sup>. PARPs are key players in DNA damage response: they recognize and bind single-strand DNA breaks and other DNA lesions and induce the repair process <sup>13, 128</sup>. PARP inhibitors work possibly by preventing the release of PARPs from the site of DNA damage, which leads to stalled replication forks that are normally repaired via HR. In mutant cells lacking functional *BRCA1* or *BRCA2*, the inability to repair and restart the stalled replication forks via HR leads to programmed cell death, or the DNA damage is repaired via a more error-prone mechanism, such as NHEJ, leading to genomic instability. The synthetic lethal interaction of *PARP* with *BRCA1* and *BRCA2* can be exploited in cancer therapy, and the PARP inhibitor olaparib has been shown to confer good responses in breast and ovarian cancer patients with *BRCA1* or *BRCA2* mutations <sup>128-130</sup>.

While heterozygous *BRCA2* and *BRCA1* mutations predispose to breast and ovarian cancer, biallelic (i.e. homozygous or compound heterozygous) mutations in the genes cause the FA subtypes FANCD1 and FANCS <sup>15, 131</sup>. FA is a rare chromosomal instability disorder that is characterized by progressive bone marrow failure, congenital abnormalities, and an increased risk of cancer, particularly leukemia and squamous cell cancers. Cells of FA patients are hypersensitive to agents that generate ICLs, such as mitomycin C <sup>15</sup>. To date, approximately 20 FA genes have been identified. While *BRCA2* is a bona fide FA gene, biallelic mutations in *BRCA1* cause FA-like disorder that lacks some of the classical features of FA such as bone marrow failure.

### **2.5.1.2 Cancer-predisposition syndromes**

Germline mutations in other high-risk genes cause rare dominantly inherited cancer-predisposition syndromes where breast and ovarian cancer are among the clinical features <sup>2, 3</sup>. *TP53*, *PTEN*, *STK11*, *CDH1*, and *NF1* are mainly associated with breast cancer and MMR genes with ovarian cancer (Table 1). Mutations in these genes are much rarer than *BRCA1* or *BRCA2* mutations. As most of the published studies are based on high-risk families presenting classical cancer-predisposition syndromes, reliable risk estimates for breast or ovarian cancer are lacking due to ascertainment bias <sup>3</sup>. Thus, the risks may be overestimated and some of the genes might be more appropriately categorized as moderate-risk genes.

Germline *TP53* mutations cause Li-Fraumeni syndrome (LFS) characterized by a high risk and an early onset of cancer, especially breast cancer, childhood sarcomas, brain tumors, and adrenocortical carcinoma <sup>132, 133</sup>. Among female *TP53* mutation carriers, breast cancer is the most common and an increased ovarian cancer incidence has also been reported <sup>109</sup>. Mai *et al.* <sup>109</sup> recently estimated a high, 85% cumulative risk of breast cancer by age 60. *PTEN*

mutations cause *PTEN* Hamartoma Tumor syndrome (PHTS) characterized by macrocephaly, multiple hamartomas, and increased risks of malignant and benign tumors, mainly of the breast, thyroid, and endometrium<sup>110, 134</sup>. The lifetime breast cancer risk for women with germline *PTEN* mutations has been estimated at 67–85%<sup>110</sup>. *STK11* mutations predispose to Peutz–Jeghers syndrome (PJS) characterized by mucocutaneous pigmentation, gastrointestinal polyposis, and an increased risk of cancer, especially gastrointestinal and breast cancer<sup>111, 135</sup>. The estimated cumulative risk of breast cancer for PJS patients is 31–54% by age 60<sup>111</sup>. An increased risk of ovarian cancer has also been reported, but mainly for sex cord ovarian tumors rather than for epithelial ovarian tumors. *CDH1* mutations predispose to hereditary diffuse gastric cancer and to breast cancer, particularly of the lobular subtype<sup>112, 136</sup>. The estimated cumulative risk of breast cancer for female *CDH1* mutation carriers is 42% by 80 years<sup>112</sup>. *NF1* mutations predispose to neurofibromatosis type 1, characterized by cutaneous neurofibromas, pigmentary changes, and an increased risk of cancer. *NF1* mutations are estimated to confer moderately increased risk of breast cancer<sup>3</sup>. For women under 40 years, however, some studies have estimated a high, approximately 6.5 to 11-fold elevated risk of breast cancer<sup>113, 114</sup>. An increased risk of ovarian cancer has also been reported<sup>137</sup>.

Mutations in the MMR genes *MLH1*, *MSH2*, *MSH6*, and *PMS2* cause Lynch syndrome, which predisposes to colorectal cancer as well as to certain extracolonic cancers<sup>35-38, 115</sup>. For women with Lynch syndrome, gynecological cancers are the most common extracolonic malignancies, with an estimated lifetime risk of 30–45% for endometrial cancer and 6–14% for ovarian cancer<sup>115</sup>. The ovarian cancers in women with Lynch syndrome are most commonly endometrioid tumors, and they develop at an earlier age than sporadic or *BRCA1/2*-associated ovarian cancers<sup>138</sup>. However, they are often diagnosed at an earlier stage and thus have a better overall survival.

*TP53* encodes a transcription factor that inhibits cell growth and stimulates apoptosis in response to cellular stress, whereas the MMR genes correct base–base mispairs<sup>2, 17</sup>. In contrast, *PTEN*, *STK11*, *CDH1*, and *NF1* differ from other susceptibility genes as their main function is not in DNA repair or genome maintenance. The *PTEN* phosphatase and the *STK11* serine/threonine kinase regulate the PI3K–AKT–mTOR and AMPK pathways involved in cell cycle regulation, cell metabolism, growth, and survival; *CDH1* encodes transmembrane glycoprotein E-cadherin, which is involved in cell adhesion; and the neurofibromin *NF1* is a GTPase activating protein that regulates the RAS signaling pathway.

## 2.5.2 MODERATE-PENETRANCE GENES

Moderate-penetrance susceptibility genes for breast and ovarian cancer have been identified mainly through candidate gene studies in breast or ovarian cancer families, but recently, exome and genome sequencing have been increasingly utilized for gene discovery<sup>2, 3</sup>. Established moderate-penetrance

breast cancer susceptibility genes include *ATM*, *CHEK2*, and *PALB2*, whereas *BRIP1*, *RAD51C*, and *RAD51D* are ovarian cancer susceptibility genes (Table 4) <sup>2, 3, 116-122, 139-143</sup>.

*ATM* is a serine/threonine protein kinase involved in DNA damage checkpoint control and HR repair <sup>2</sup>. Heterozygous carriers of truncating *ATM* mutations have approximately a 3-fold increased risk of breast cancer <sup>3, 116</sup>. Biallelic mutations in *ATM* cause ataxia-telangiectasia, a neurodegenerative disorder with immunodeficiency and an increased risk of cancer, particularly leukemia and lymphoma <sup>116, 131</sup>. The checkpoint kinase *CHEK2* is the downstream target of *ATM* in DNA damage checkpoint control and further regulates cell cycle and apoptosis <sup>2</sup>. Most of the studies on *CHEK2* and breast cancer risk are based on a truncating mutation c.1100delC which is observed fairly frequently in Northern and Eastern European populations but is absent in many other populations <sup>3, 117, 118</sup>. Women with a *CHEK2* c.1100delC have approximately a 2 to 3-fold increased risk of breast cancer, while for women with a family history of breast cancer, the risk is even higher <sup>117, 118</sup>. *CHEK2* mutations also increase the risk of male breast cancer <sup>144</sup>.

The major role of *PALB2*, *BRIP1*, *RAD51C*, and *RAD51D* is in HR repair of DSBs <sup>2</sup>. Heterozygous *PALB2* mutations increase the risk of breast cancer and heterozygous *BRIP1*, *RAD51C*, and *RAD51D* mutations the risk of ovarian cancer, whereas biallelic *PALB2*, *BRIP1*, and *RAD51C* mutations cause the FA subtypes FANCN, FANCI, and FANCO, respectively <sup>2, 3, 15, 119-122, 139-141</sup>. For women with heterozygous pathogenic *PALB2* mutations, recent reports have estimated a 5.3-fold relative risk of breast cancer <sup>3</sup> and a cumulative risk of 35% by age 70 <sup>119</sup>, thus potentially placing *PALB2* into the high-risk category. Family history of the disease further increases the risk of breast cancer for *PALB2* mutation carriers to a cumulative risk of 58% by age 70 <sup>119</sup>. *PALB2* mutations also increase the risk of male breast cancer, but are not significantly associated with ovarian cancer risk <sup>120, 144</sup>. In contrast, pathogenic *BRIP1*, *RAD51C*, and *RAD51D* mutations confer a moderate to high risk of ovarian cancer, but are not significantly associated with breast cancer <sup>120-122, 140, 145</sup>. Based on a case-control analysis, the estimated relative risk of ovarian carcinoma associated with heterozygous *BRIP1* mutations was 11, whereas a segregation analysis in families yielded an average relative risk of 3.4 compared to the general population, and a cumulative risk of 5.8% by age 80 <sup>120</sup>.

*RAD51C* was originally proposed as a breast and ovarian cancer susceptibility gene by Meindl *et al.* in 2010 <sup>139</sup>. Six heterozygous pathogenic *RAD51C* mutations were observed among 480 breast-ovarian cancer families, whereas breast-cancer-only families and healthy controls did not harbor mutations. In an accompanying paper, Vaz *et al.* reported a homozygous *RAD51C* missense mutation in a patient with FA-like disease <sup>146</sup>. Most of the early studies following the initial report by Meindl *et al.* failed to identify clearly pathogenic mutations among breast or ovarian cancer patients, indicating that *RAD51C* mutations are very rare <sup>147-150</sup>. After the publication of Study I, Loveday *et al.* confirmed the association of *RAD51C* mutations with ovarian cancer (RR = 5.88, 95% CI =

2.91–11.9,  $p = 7.65 \times 10^{-7}$ ) and estimated a >9% cumulative risk by age 80, whereas they observed no evidence of association for breast cancer (RR = 0.91, 95% CI = 0.45–1.86,  $p = 0.8$ )<sup>121</sup>. *RAD51D* was first identified as an ovarian cancer susceptibility gene by Loveday *et al.* in 2011<sup>122</sup>. They identified eight deleterious *RAD51D* mutations among 911 breast-ovarian cancer families and one among 1060 controls, with a higher prevalence of mutations in families with more than one ovarian cancer case. Based on a modified segregation analysis, they estimated a 6.30-fold (95% CI = 2.86–13.9,  $p = 4.8 \times 10^{-6}$ ) increased risk of ovarian cancer for mutation carriers, indicating an approximately 10% lifetime risk, but no significant association with breast cancer (RR = 1.32, 95% CI = 0.59–2.96,  $p = 0.50$ )<sup>122</sup>. Loveday *et al.* also demonstrated that *RAD51D* deficient cells are sensitive for PARP inhibitors. The functions of *RAD51C* and *RAD51D* are described in more detail in section 2.8.

Heterozygous mutations in the *NBN* gene have also been associated with an increased risk of breast cancer, but currently there is clear evidence for only one truncating mutation, c.657\_661delACAAA (657del5), which is common in some Eastern European populations<sup>3, 151</sup>. Biallelic *NBN* mutations cause Nijmegen breakage syndrome, which is characterized by microcephaly, typical facies, immunodeficiency, and an increased risk of lymphomas and other cancers<sup>131</sup>. *NBN* encodes nibrin, which is part of the MRE11/*RAD50*/*NBN* (MRN) complex involved in HR repair and checkpoint signaling<sup>2</sup>. Recently, we identified a *FANCM* nonsense mutation in an exome sequencing of breast cancer families, and subsequent case-control analysis indicated an association especially with triple-negative breast cancer (TNBC)<sup>152</sup>. Similar results have been obtained in other studies, but further research is required to draw reliable and more precise risk estimates for *FANCM* mutation carriers. The *FANCM* protein is important for replication-fork protection and ICL repair via the FA pathway, but biallelic mutations in the gene do not cause FA syndrome<sup>2, 15, 153, 154</sup>. Several other DNA repair genes have been suggested as susceptibility genes for breast and ovarian cancer, such as the MRN complex genes *MRE11* and *RAD50* and the FA pathway gene *FANCC*, but the current evidence for these genes is more limited<sup>2, 3</sup>.

### 2.5.3 LOW-PENETRANCE VARIANTS

Through genome-wide association studies (GWAS), close to 200 low-penetrance susceptibility loci for breast cancer and over 30 for ovarian cancer have been identified thus far<sup>99, 100</sup>. While some of the identified variants are associated with both breast and ovarian cancer, some are only associated with specific subtypes, such as ER-negative breast cancer or clear cell or mucinous ovarian cancer<sup>99, 155–158</sup>. The low-penetrance variants are typically single-nucleotide polymorphisms (SNP) in non-coding regions. Many of them likely function by regulating the expression of nearby genes, yet the actual causal variant or the target gene has not been identified for most of the susceptibility loci<sup>69, 99, 100, 156</sup>. Most of the predicted candidate genes function in pathways related to mammary gland development, DNA repair, cell cycle control, and ER signaling.

The known low-penetrance breast cancer susceptibility loci are estimated to account for approximately 18% of the familial relative risk <sup>100</sup>. Based on a polygenic risk score (PRS) of 77 susceptibility loci, women in the highest 20% of the risk distribution are estimated to have a 16.6% lifetime risk of breast cancer, while women in the lowest 20% have only a 5.3% lifetime risk <sup>98</sup>. Family history increases the lifetime risk further to 24.4% for the women in the highest quintile. When including all the identified risk SNPs, women in the highest 1% of the distribution are estimated to have a 3.5-fold increased risk of breast cancer <sup>100</sup>. The low-risk SNPs, their combined effects in particular, modify the breast cancer risk also in *BRCA1/2* and *CHEK2* mutation carriers <sup>159-161</sup>. Importantly, a high PRS puts women with the moderate-penetrance *CHEK2* c.1100delC mutation into the high-risk category <sup>161</sup>.

For ovarian cancer, the known low-penetrance susceptibility loci are estimated to account for approximately 6.4% of the polygenic risk in the population <sup>99</sup>. PRS based on 17 SNPs was estimated to have low power for risk-discrimination in the population, but among *BRCA1/2* mutation carriers, PRS was strongly associated with ovarian cancer risk and its incorporation into risk prediction models could allow more precise risk estimates for the mutation carriers <sup>160, 162</sup>.

#### 2.5.4 FINNISH FOUNDER MUTATIONS

Isolated founder populations, such as the Finnish population, have a unique genetic background and are typically genetically more homogeneous than larger and more outbred populations <sup>163</sup>. Recent bottlenecks and isolation have led to the enrichment of certain alleles, while others have disappeared. In Finns, a smaller number of rare variants with MAF < 0.5% has been observed, while loss-of-function and low-frequency variants with MAFs between 2% and 5% are enriched <sup>164, 165</sup>.

The majority of pathogenic mutations in breast and ovarian cancer susceptibility genes in the Finnish population are accounted for by only a few recurrent founder mutations. Founder mutations have been observed, for instance, in *BRCA1*, *BRCA2*, *PALB2*, and *FANCM* <sup>152, 166, 167</sup>. In *CHEK2*, the c.1100delC mutation is most prevalent in Finland and the Netherlands, while it is less frequent or absent in other populations <sup>118, 168</sup>.

Despite the seemingly homogeneous genetic profile of Finns, there is also substantial genetic variation between Finnish subpopulations <sup>169, 170</sup>. Thus, certain mutations cluster in different geographical regions and allele frequencies may differ between subpopulations. In *BRCA1* and *BRCA2*, for example, several founder mutations have been observed which cluster in different geographical regions in Finland <sup>166</sup>. These mutations explain the majority of all observed pathogenic *BRCA1/2* mutations in Finland; some of them are unique to the Finnish population, while some have been observed elsewhere as well.

## 2.6 INHERITED SUSCEPTIBILITY TO PROSTATE CANCER

In developed countries, prostate cancer is the most frequently diagnosed cancer among men, whereas worldwide it ranks second with an estimated 1.1 million cases diagnosed in 2012 <sup>1</sup>. In Finland, 4855 prostate cancer cases and 921 deaths occurred in 2015 <sup>4</sup>. Globally, over 300 000 prostate cancer deaths were estimated to have occurred in 2012 <sup>1</sup>. The prognosis for prostate cancer is good, with a 94% relative 5-year survival ratio in Finland <sup>4</sup>.

Even though epidemiological studies have suggested environmental and lifestyle risk factors for prostate cancer, no such risk factors have been convincingly linked to prostate cancer <sup>171, 172</sup>. Family history, however, is an established risk factor: first-degree relatives of men with prostate cancer have an approximately two-fold increased risk. Heritability of prostate cancer is estimated to be as high as 57% <sup>68</sup>. While only a few rare, high-penetrance mutations for prostate cancer have been identified, numerous common, low-risk variants have been recognized <sup>171, 172</sup>. To date, the transcription factor *HOXB13* remains the only moderate to high-risk susceptibility gene identified that predominantly predisposes to prostate cancer <sup>171-173</sup>. A pathogenic missense mutation, G84E in the *HOXB13* gene, is particularly frequent in the Finnish population <sup>174</sup>. Mutations in the breast cancer susceptibility gene *BRCA2* also increase the risk of prostate cancer and predispose to a more aggressive disease <sup>171, 172, 175, 176</sup>. Data for *BRCA1* is less clear, with some evidence for moderately increased prostate cancer risk <sup>171, 172, 176, 177</sup>. Several other breast or ovarian cancer susceptibility genes with a function in DNA repair, including *PALB2*, *CHEK2*, and *BRIP1*, have also been investigated <sup>171, 172, 176</sup>. For these genes, there is some evidence of association with prostate cancer, but the data is more inconclusive. Nevertheless, 11.8% of men with metastatic prostate cancer harbor germline mutations in DNA repair genes, with *BRCA2* mutations being the most frequent <sup>176</sup>. More than 100 low-risk loci for prostate cancer predisposition have been identified through GWAS, with some shared loci between breast, ovarian, and prostate cancer <sup>155, 178, 179</sup>. Together, the known risk loci are estimated to explain approximately 39% of the familial risk of prostate cancer <sup>179</sup>.

## 2.7 INHERITED SUSCEPTIBILITY TO COLORECTAL CANCER

Colorectal cancer is the second most common cancer among women and the third among men, both worldwide and in more developed countries, with an estimated 1.4 million cases diagnosed in the world in 2012 <sup>1</sup>. In Finland, 1014 female and 981 male colon cancers as well as 460 female and 708 male rectum cancers were diagnosed in 2015 <sup>4</sup>. Globally, almost 700 000 colorectal cancer deaths were estimated to have occurred in 2012, and in Finland, 1197 colorectal cancer deaths were observed in 2015 <sup>1, 4</sup>. The prognosis of colorectal cancer has been

improving in many Western countries, with almost 65% 5-year relative survival ratios observed in high-income countries <sup>180</sup>. In Finland, the 5-year relative survival is 66% <sup>4</sup>.

Colorectal cancer incidence has been linked to the Western lifestyle, with potentially modifiable risk factors such as smoking, high consumption of alcohol and red or processed meat, obesity, and diabetes accounting for a large proportion of the disease burden at the population level <sup>180</sup>. Inflammatory bowel disease and family history of colorectal cancer are stronger, if rarer, risk factors. First-degree relatives of colorectal cancer patients have an approximately two-fold increased risk. While colorectal cancer is estimated to have a high 40% heritability, the estimates for colon and rectal cancers individually are relatively smaller than for other cancer types, at 15% and 14%, respectively <sup>68, 181</sup>.

A small proportion of colorectal cancers are due to rare, high-penetrance mutations in genes that predispose to hereditary syndromes with early-onset colorectal cancer <sup>38, 182</sup>. The most common form is Lynch syndrome, which is caused by mutations in the MMR genes *MLH1*, *MSH2*, *MSH6*, and *PMS2* <sup>35-38, 182</sup>. A hallmark of Lynch syndrome is microsatellite instability resulting from defective mismatch repair <sup>38, 182</sup>. The most severe form of polyposis syndromes, familial adenomatous polyposis, is caused by highly-penetrant mutations in the *APC* gene involved in the Wnt signaling pathway, which controls cell division, adhesion, and migration <sup>38, 182, 183</sup>. In contrast to the other, dominantly inherited syndromes, *MUTYH*-associated polyposis is a recessive form of adenomatous polyposis caused by biallelic mutations in the *MUTYH* gene, which is involved in base-excision repair <sup>182, 184</sup>. Mutations in the DNA polymerase genes *POLE* and *POLD1* cause polymerase-proofreading-associated polyposis characterized by hypermutated, but microsatellite-stable colorectal tumors <sup>182, 185</sup>. Mutations in the TGF $\beta$ /BMP signaling pathway genes *SMAD4* and *BMPRI1A* predispose to juvenile polyposis syndrome <sup>182, 186, 187</sup>. Colorectal cancer is also part of the clinical spectrum of PHTS and PJS, caused by mutations in the *PTEN* and *STK11* genes, respectively <sup>38, 134, 135, 182</sup>. However, mutations in the known susceptibility genes explain less than half of the cases of familial colorectal cancer <sup>188</sup>. Some of the excess familial risk for colorectal cancer is likely explained by unidentified high-risk genes, and some by common low-risk variants <sup>180, 188</sup>. To date, over 40 low-risk loci have been identified through numerous GWAS <sup>182, 189</sup>.

## 2.8 RAD51 PARALOGS

The five human RAD51 paralogs – RAD51B, RAD51C, RAD51D, XRCC2, and XRCC3 – play an essential role in DNA damage repair via HR <sup>14</sup>. HR is an error-free mechanism to repair DSBs in mammalian cells as it uses the homologous DNA sequence on the sister chromatid as a template. HR is also crucial for the repair and restart of stalled replication forks. In DSB repair, the DNA ends at the break site are first processed to reveal single-stranded DNA, and the repair process is initiated by the binding of RAD51 recombinase. The RAD51 monomers

assemble around the single-stranded DNA to form a nucleoprotein filament that catalyzes strand invasion and pairing with the intact homologous DNA molecule to form heteroduplex DNA. The RAD51 paralogs, along with BRCA2, help to recruit the RAD51 recombinase to the break site. RAD51 paralog deficient cells are sensitive to DNA damaging agents and lack the ability to form RAD51 foci in response to ionizing radiation <sup>14,190</sup>. Disruption of any of the Rad51 paralog genes in mice causes early embryonic lethality and accumulation of unrepaired DNA damage.

The RAD51 paralogs form two major complexes in cells: the BCDX2 complex formed by RAD51B, RAD51C, RAD51D, and XRCC2, and the CX3 complex formed by RAD51C and XRCC3 (Figure 1) <sup>191</sup>. The BCDX2 complex has been shown to act in the early stage of HR – upstream of the RAD51 recruitment to the damage site – whereas the CX3 complex acts downstream of RAD51 recruitment <sup>192</sup>. The RAD51 paralogs share a highly conserved central domain with Walker A and Walker B consensus motifs, which confer ATP binding and hydrolysis activities <sup>193</sup>. An intact  $\beta$ -sheet in the C-terminus of the paralogs is needed for a proper folding of the proteins <sup>194</sup>. All paralogs, except XRCC2, which lacks the N-terminal domain, have a linker region between N and C-terminal domains, which is important for the interactions between the paralogs (Figure 1) <sup>194</sup>.

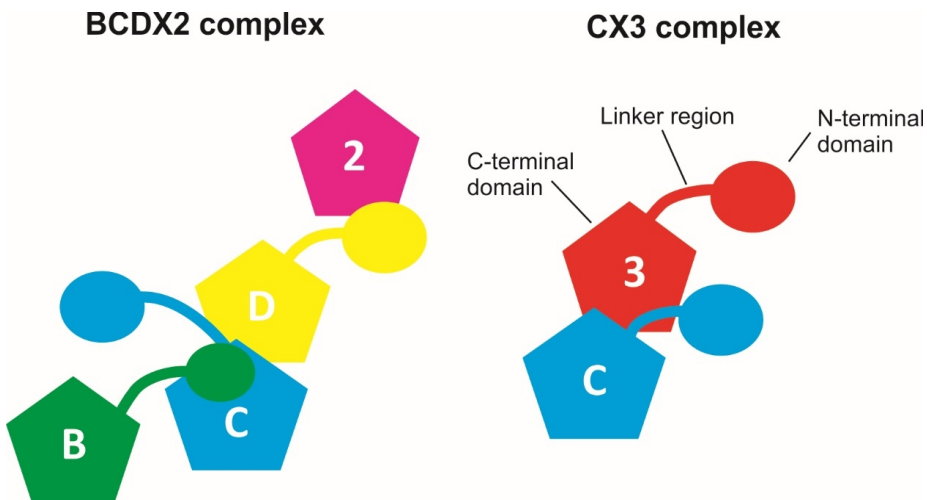

**Figure 1** Schematic representation of the BCDX2 and CX3 complexes and the RAD51 paralogs. Adapted from Suwaki *et al.* 2011 <sup>14</sup>. Reprinted with permission from Elsevier.

### 2.8.1 RAD51C

RAD51C is the only RAD51 paralog that is detected in both the BCDX2 and CX3 complex (Figure 1) and it also forms additional sub-complexes with RAD51B, XRCC3, and RAD51D as well as with both RAD51D and XRCC2 together <sup>14,191</sup>. It also binds to PALB2 and forms a complex with PALB2, BRCA2, and RAD51 <sup>195</sup>.



The *RAD51C* gene, located on chromosome 17, encodes a 376-amino-acid long protein<sup>196</sup>. In addition to the conserved N and C-terminal domains shared by the paralogs, RAD51C has a nuclear localization signal in the C-terminus, which is absent in RAD51 and most of the other paralogs<sup>14, 197</sup>. While the C-terminal region is required for the nuclear localization and RAD51 paralog complex formation, the N-terminal region of RAD51C is necessary for interaction with an E3 ubiquitin ligase RAD18, which is involved in DNA damage signaling<sup>194, 197, 198</sup>. RAD18 binds to the break site on DNA and links DNA damage checkpoint response to DNA repair via its direct interaction with RAD51C. Loss of the RAD51C N-terminal region confers cells sensitive to DNA damaging agents and causes defects in HR, but does not affect RAD51 paralog complex formation. RAD51C is also required for CHEK2 activation and cell-cycle arrest in response to DNA damage<sup>199, 200</sup>.

RAD51C has a role in both the early and late stages of HR<sup>14</sup>. The early role of the RAD51 paralogs is to aid RAD51 nucleoprotein filament assembly, while the late role of RAD51C is in the processing of Holliday junctions, the intermediate crossover structures between the damaged DNA and the undamaged homologous chromosome<sup>14, 201</sup>. Consistent with both an early and a late function, RAD51C accumulates at DNA damage sites together with RAD51, and persists after RAD51 has disassembled<sup>199</sup>. In addition to the repair of DSBs, RAD51C is also required for the downstream HR step of ICL repair via the FA pathway<sup>200</sup>. Other roles for RAD51C in genome maintenance include protection of stalled replication forks and maintenance of correct centrosome numbers in mitosis<sup>202, 203</sup>.

Rad51c has been shown to function as a tumor suppressor in mice<sup>204, 205</sup>. However, deletion of Rad51c alone is not sufficient to drive tumorigenesis, whereas deletion of Rad51c together with Trp53 leads to tumor progression<sup>206</sup>. Studies in hamster cells indicate that Rad51c haploinsufficiency causes increased DNA damage sensitivity and genomic instability, and thus may contribute to tumorigenesis<sup>207</sup>. In ER-positive breast cancer cells, estrogen has been shown to regulate RAD51C expression and to induce the formation of nuclear RAD51C foci<sup>208</sup>.

## **2.8.2 RAD51D**

The *RAD51D* gene is located on chromosome 17 and encodes a 328-amino-acid long protein<sup>209</sup>. RAD51D has been shown to act in the early steps of HR repair and is part of the BCDX2 complex<sup>192</sup>. The N-terminal domain of RAD51D binds to XRCC2 and single-stranded DNA, while the C-terminal domain binds RAD51C<sup>194</sup>. Moreover, the conserved ATPase motif is required for the interaction of RAD51D with RAD51C and XRCC2 and for proper HR function<sup>210, 211</sup>. RAD51D also binds to the BLM helicase involved in the processing of Holliday junctions<sup>212</sup>. The RAD51D-XRCC2 complex can stimulate the disruption of synthetic Holliday junctions by BLM, indicating that RAD51D also plays a role in the late stages of HR. In addition to its role in DSB repair,

RAD51D is needed for telomere maintenance through HR <sup>213</sup>. Telomeres protect chromosome ends from degradation and fusion; RAD51D-deficient cells show telomere shortening, loss of telomere capping, and increased levels of chromosomal aberration. Furthermore, RAD51D-deficient mouse cells display extensive chromosome instability and decreased radiation-induced RAD51-focus formation and are hypersensitive to DNA damaging agents <sup>214</sup>.

## 2.9 RAD54L

RAD54L is another DNA repair protein that functions in HR together with RAD51 <sup>215</sup>. The *RAD54L* gene encodes a DNA translocase with double-stranded DNA-dependent ATPase activity, that belongs to the Swi2/Snf2 family of motor proteins. RAD54L functions in DNA repair by stabilizing the interaction of RAD51 with single-stranded DNA, by promoting strand invasion, and by removing RAD51 from the double-stranded heteroduplex DNA <sup>14,215,216</sup>. The disassociation of RAD51 from the double-stranded DNA after strand exchange is important in order to make the 3' ends of the invading single-stranded DNA accessible for the DNA polymerase to use as primers for the DNA repair synthesis. In addition to removing RAD51 from the heteroduplex DNA during damage repair, RAD54L also prevents the accumulation of RAD51 on undamaged DNA. RAD51 is often expressed at high levels in tumors, which can lead to toxic formation of RAD51 foci on undamaged chromatin. Depletion of RAD54L and its paralog RAD54B in tumor cells leads to accumulation of RAD51 foci on undamaged DNA, which further leads to defects in replication and chromosome segregation <sup>216</sup>. Given its role in the HR repair of DNA damage, *RAD54L* is a potential candidate gene for breast and ovarian cancer susceptibility.

## 2.10 NEXT-GENERATION SEQUENCING IN CANCER RESEARCH AND DIAGNOSTICS

The development of NGS methods has revolutionized genomics and cancer research as they allow a much cheaper and quicker way of sequencing DNA or RNA than the traditional Sanger method <sup>217</sup>. In NGS, vast numbers of short reads are sequenced in parallel. Various technologies exist, but they all rely on the preparation of sample libraries from input DNA or RNA. The different technologies can be applied to whole-genome sequencing, or to whole-exome sequencing, which is restricted to the protein-coding part of the genome. In more targeted applications, selected regions of the genome are first amplified by PCR, which allows analysis of a panel of disease genes, for example.

In the research setting, new putative breast and ovarian cancer susceptibility genes have been discovered through whole-exome and targeted sequencing studies <sup>2</sup>. In a clinical diagnostic setting, gene panels are now increasingly utilized, as they allow a rapid and cost-effective analysis of multiple genes

simultaneously<sup>3</sup>. Clinical genetic testing of high-risk women, such as familial or early-onset breast and ovarian cancer patients, was long restricted to the *BRCA1* and *BRCA2* genes. As many more susceptibility genes are now recognized, these single-gene tests would leave numerous women without a genetic diagnosis despite their potentially actionable mutations. Moreover, in some families more than one risk variant segregates. In recent gene-panel studies, mutations in genes other than *BRCA1* and *BRCA2* have been detected in approximately 4–6% of hereditary breast and ovarian cancer patients<sup>218</sup>. Thus, gene panels allow more comprehensive testing than single-gene tests, allowing more women to receive a genetic diagnosis. However, many commercially available gene panels include numerous cancer predisposition genes of which only some have clinical utility for breast or ovarian cancer<sup>3</sup>. To have clinical validity for breast cancer, Easton *et al.* estimated that there is sufficient evidence of association only for *BRCA1*, *BRCA2*, *TP53*, *CDH1*, *PTEN*, *STK11*, *NF1*, *PALB2*, *CHEK2*, *ATM*, and *NBN*<sup>3</sup>. For *RAD51C*, *RAD51D*, and *BRIP1*, there is currently clear evidence of association with ovarian cancer<sup>3, 120-122</sup> (I, II). Missense variants are typically more difficult to interpret than protein-truncating mutations, and variants of unknown significance are often discovered even in the established risk-genes. Thus, much more research is needed to provide more precise risk estimates for a large number of putative susceptibility genes included in the gene panels.

### 3 AIMS OF THE STUDY

The aim of this thesis was to find and characterize new cancer-predisposing mutations in the *RAD51* paralogs *RAD51C* and *RAD51D* as well as in the *RAD54L* gene, and to investigate high-risk breast and ovarian cancer patients with a gene panel. The specific aims of the study were:

1. To identify *RAD51C* germline mutations in Finnish breast and ovarian cancer families and to determine their role in breast and ovarian cancer predisposition.
2. To identify germline mutations in the *RAD51D* and *RAD54L* genes in breast and ovarian cancer families and to determine whether the identified mutations are associated with breast, ovarian, prostate, and colorectal cancer risk in the Finnish population.
3. To determine the role of the Finnish *RAD51C* founder mutations in prostate and colorectal cancer predisposition.
4. To determine the mutation spectrum of the known breast and ovarian cancer susceptibility genes in high-risk breast and ovarian cancer patients with a gene panel and to characterize the identified *RAD51C* duplication and its role in breast and ovarian cancer predisposition.

## 4 MATERIALS AND METHODS

### 4.1 SUBJECTS

In Studies I and II, familial breast and ovarian cancer patients from the Helsinki region of Finland were first screened for germline variation in the *RAD51C* (n = 277) and *RAD51D* and *RAD54L* genes (n = 95). The identified truncating *RAD51C* mutations and the missense variant were further genotyped in unselected (n = 884) and additional familial breast cancer patients (n = 491), unselected ovarian cancer patients (n = 409), and population controls (n = 1279) from Helsinki (I). The truncating mutations were also genotyped in breast cancer patients (n = 686) and population controls (n = 807) from the Tampere region (I) as well as in prostate (n = 1083) and colorectal cancer cases (n = 802) from Tampere and southeastern Finland, respectively (III). The identified *RAD51D* mutation was genotyped in unselected breast cancer patients (n = 849), additional familial breast or ovarian cancer patients (n = 680), unselected ovarian cancer patients (n = 541), and population controls (n = 1287) from the Helsinki region, in breast (n = 691) and prostate cancer patients (n = 1094) and population controls (n = 815) from the Tampere region, as well as in colorectal cancer patients (n = 980) from southeastern Finland (II).

In Study IV, 95 high-risk breast or ovarian cancer patients were tested with a gene panel. The identified *RAD51C* duplication was further screened in unselected breast (n = 1729) and ovarian cancer patients (n = 553), additional familial breast or ovarian cancer patients (n = 800), and population controls (n = 1273) from the Helsinki region.

Relatives with samples available from the mutation carrier families were analyzed for the respective mutations (I, II, IV). All samples consisted of genomic DNA isolated from peripheral blood of the subjects, except for 124 samples from unselected ovarian cancer patients, which were tumor DNA, and for the colorectal cancer samples, which were genomic DNA isolated from blood or normal mucosa.

#### 4.1.1 HELSINKI BREAST AND OVARIAN CANCER SERIES (I, II, IV)

The unselected breast cancer patient series from Helsinki consisted of two cohorts collected at the Helsinki University Hospital Department of Oncology in 1997–1998 and 2000 (n = 884)<sup>106, 219</sup> and the Department of Surgery in 2001–2004 (n = 886)<sup>220</sup>. The series cover 79% and 87% of all consecutive, newly diagnosed breast cancer patients, unselected for age or family history, during the collection periods. Only invasive female patients were included in the analyses. Additional familial breast and ovarian cancer patients were ascertained at the Helsinki University Hospital Department of Oncology through systematic

screening (1993-) and at the Department of Clinical Genetics through genetic counselling in an ongoing collection<sup>168, 220, 221</sup>.

After combining patients with a positive family history from the unselected series (n = 383) and the additional familial patients, 1149 patients were included in the familial cohort. These comprised 592 families with at least three breast or ovarian cancer cases among first or second-degree relatives, 549 families with two breast or ovarian cancers in first-degree relatives, and 8 families with at least two ovarian cancers among first-degree relatives with no known family history of breast cancer. The patients had been tested negative for *BRCA1/2* mutations and their genealogies confirmed through population registries and all cancer diagnoses in the Finnish Cancer Registry or in hospital records. Information on the tumor histology, grade, size, nodal status, distant metastases at diagnosis, and ER and PR-status was collected from pathology reports<sup>222</sup>. HER2-status was based on immunohistochemistry and on gene amplification with chromogenic in situ hybridization on tumor microarrays (CISH), as previously described<sup>223</sup>.

The unselected ovarian cancer patient series was collected at the Helsinki University Hospital Department of Obstetrics and Gynecology in 1998–2006. Blood samples from 233 patients were retrospectively collected in 1998 as previously described<sup>107</sup>. The patients had been treated for invasive epithelial ovarian carcinoma at the Helsinki University Hospital between 1989 and 1998 and the samples were collected during routine follow-up visits to the clinic in 1998 from patients who were still alive. Additional blood or tumor tissue samples were prospectively collected from 320 patients treated for ovarian carcinoma at the Helsinki University Hospital Department of Obstetrics and Gynecology between 1998 and 2006. Up to 429 genomic and 124 tumor DNA samples were included in the analyses.

#### **4.1.2 GENE-PANEL SEQUENCING SAMPLES (IV)**

A total of 95 high-risk breast or ovarian cancer patients referred to clinical genetic testing were studied with a gene panel. The patients were ascertained at the Helsinki University Hospital Department of Clinical Genetics and they fulfilled the following criteria: at least three breast or ovarian cancer cases among first or second-degree relatives, proband included (n = 35), two breast or ovarian cancer cases among first-degree relatives, proband included (n = 23), male breast cancer cases (n = 5), early-onset breast cancer cases diagnosed at the age of 40 or younger (n = 18), TNBC cases diagnosed at the age of 50 or younger (n = 10), or patients who were affected with breast and ovarian (n = 3) or breast and colorectal cancer (n = 1) and who had a family background of other cancers. Information on family history was collected from patient interviews whereafter most of the cancer cases were verified from clinical records. Male relatives were excluded when calculating the degree of relationship for the breast cancer families. Altogether 13 patients had been previously screened negative for the Finnish *BRCA1/2* founder mutations and 4 patients for the full *BRCA1/2* genes. In

addition, three patients had a family member previously screened negative for the *BRCA1/2* founder mutations or the full genes.

#### **4.1.3 TAMPERE BREAST CANCER SERIES (I, III)**

An unselected breast cancer series was collected at Tampere University Hospital and comprised 408 consecutive patients recruited between 1997 and 1999 and an additional 336 incident cases recruited between 1996 and 2004 <sup>106, 220</sup>.

#### **4.1.4 PROSTATE CANCER SERIES (II, III)**

An unselected series of 905 prostate cancer patients was collected in the Pirkanmaa Hospital District. The patients had been diagnosed with prostate cancer at the urology out-patient clinic at Tampere University Hospital between 1980 and 2008. An additional 189 prostate cancer families were collected as previously described <sup>224</sup>. The families included at least two prostate cancer patients, and the youngest case from each family was included in the analyses.

#### **4.1.5 COLORECTAL CANCER SERIES (II, III)**

The colorectal cancer patient series was collected at nine large regional hospitals in southeastern Finland in 1994–1996 (509 consecutive patients) and 1996–1998 (535 consecutive patients), as previously described <sup>225, 226</sup>. Altogether 158 patients had a family background of colorectal cancer.

#### **4.1.6 POPULATION CONTROLS (I, II, IV)**

The population controls were healthy female blood donors from the same geographic regions.

## **4.2 MUTATION ANALYSIS**

### **4.2.1 GENE-PANEL SEQUENCING (IV)**

Ten genes (*BRCA1*, *BRCA2*, *CDH1*, *CHEK2*, *PTEN*, *STK11*, *TP53*, *PALB2*, *RAD51C*, and *RAD51D*) were analyzed with gene-panel sequencing in 95 breast or ovarian cancer patients. The SureSelectXT Custom 3-5.9 Mb library kit (Agilent Technology) was used for DNA capture and the sequencing was performed on the Illumina HiSeq 2500 (Illumina) at Lund University. The sequencing covered the complete genes, including the introns as well as a 150 kilobase pair (kb) upstream and downstream sequence for *BRCA1* and *BRCA2*, 50 kb for *CDH1*, *CHEK2*, *PTEN*, *STK11*, and *TP53*, and 20 kb for *PALB2*, *RAD51C*, and *RAD51D*. Identified variants were annotated with snpEff <sup>227</sup> and Annovar <sup>228</sup> for their effect

on protein-coding transcripts, and only protein-truncating mutations (i.e. nonsense, splicing and frameshift indel mutations) and pathogenic missenses in the 10 studied genes were considered in this study. Copy number variants (CNV) were identified at Lund University using an in-house method based on the number of read pairs in short windows over the target regions. In addition, large genomic changes in *BRCA1* and *BRCA2* were investigated by Multiplex Ligation-dependent Probe Amplification (MLPA). Pathogenic mutations in the studied genes were verified with Sanger sequencing.

#### **4.2.2 SANGER SEQUENCING (I, II, IV)**

The *RAD51C* gene was screened for germline mutations by Sanger sequencing in 277 and the *RAD51D* and *RAD54L* genes in 95 familial breast or ovarian cancer patients (I, II). The exact size and location of the *RAD51C* ex1-7 duplication, identified in the CNV analysis of the gene-panel samples, was characterized by Sanger sequencing of the index patient (IV).

The DNA samples were amplified with polymerase chain reaction (PCR) using standard protocols. The PCR products were purified with ExoSAP-IT (Affymetrix) or A'SAP (ArcticZymes) enzymes. ABI BigDye Terminator 3.1 Cycle Sequencing kit (Applied Biosystems) was used for sequencing reactions and the sequencing was performed at the Institute for Molecular Medicine Finland (FIMM), University of Helsinki, using a 3730xl DNA Analyzer (Applied Biosystems). Sequence chromatograms were analyzed with FinchTV (Geospiza) and Variant Reporter (Applied Biosystems).

#### **4.2.3 GENOTYPING (I-IV)**

The identified *RAD51C* and *RAD51D* point mutations were genotyped by direct sequencing as described above or by TaqMan real-time-PCR with Custom TaqMan SNP genotyping assays and TaqMan Genotyping MasterMix (Applied Biosystems).

The *RAD51C* duplication was genotyped with PCR assay. The DNA samples were amplified with a forward primer in the *RAD51C* intron 7 upstream of the duplication breakpoint and a reverse primer in the duplicated sequence upstream of the *RAD51C* gene. A second reverse primer in the non-duplicated region in intron 7 was added to monitor the success of the PCR reaction. The PCR products were run on a 2% agarose gel and two bands were seen for the duplication carriers and one band for the non-carriers. All carriers were confirmed with a second PCR.

### **4.3 LOSS-OF-HETEROZYGOSITY ANALYSIS (I, II)**

Breast or ovarian tumors from nine *RAD51C* mutation carriers and four *RAD51D* mutation carriers were analyzed for loss-of-heterozygosity (LOH). Tissue cores



were punched from paraffin-embedded tumor samples and DNA was isolated by standard phenol-chloroform method or with ArchivePure DNA Blood kit (5Prime) followed by PCR and direct sequencing. The sequencing results were compared with heterozygous germline DNA isolated from blood.

#### **4.4 SPLICING ANALYSIS (I)**

Total RNA from blood samples of two *RAD51C* c.837+1G>A mutation carriers was isolated using PAXgene Blood RNA kit (Pre-Analytix) and converted into single-stranded complementary DNA (cDNA) with a High Capacity cDNA Reverse Transcription Kit (Applied Biosystems). The cDNA was amplified by PCR using primers specific for *RAD51C* exons 3 and 8. The PCR products were analyzed on 2% agarose gel and extracted with MinElute Gel Extraction kit (Qiagen) followed by Sanger sequencing. A cDNA sample from a control subject negative for the mutation was amplified by PCR followed by direct sequencing.

#### **4.5 HAPLOTYPE ANALYSIS (I, II)**

To define whether the mutation carrier families have a common ancestry, seven and eight SNP markers located within and around the *RAD51C* and *RAD51D* genes, spanning 34 and 95 kb, respectively, were screened by Sanger sequencing in family members with available DNA samples from the mutation carrier families. The haplotype analysis was performed for eight individuals from four *RAD51C* c.93delG families, six individuals from three *RAD51C* c.837+1G>A families, and ten individuals from four *RAD51D* c.576+1G>A families. Haplotypes were constructed manually.

#### **4.6 GENE-EXPRESSION AND mRNA ANALYSIS (IV)**

The *RAD51C* expression was studied in lymphoblastoid cell lines (LCL) of *RAD51C* ex1-7 duplication carriers and non-carriers. Samples of four female breast cancer patients from the *RAD51C* ex1-7 duplication family, including three duplication carriers and one non-carrier, were compared to a reference sample from an unrelated healthy non-carrier woman. The LCLs were cultured in RPMI (Lonza) supplemented with 10% FBS (Gibco), 1% glutamine, and 1% streptomycin-penicillin at +37°C in a humidified chamber with 5% CO<sub>2</sub>. Gene-expression analysis was performed with Cells-to-CT 1-Step TaqMan Kit (Ambion) and TaqMan gene-expression assays (Applied Biosystems) according to the manufacturers' protocols. To ensure that no genomic DNA would be detected in the expression analysis, the cells were treated with DNase and then TaqMan gene-expression assays that bind to exon boundaries were selected. Two *RAD51C* gene-expression assays (Hs00427442\_m1 and Hs00980059\_m1) that bind to the exon 1-2 and 8-9 junctions were used to measure *RAD51C* expression and an

*ACTB* assay (Hs99999903\_m1) was used as an endogenous control. Four independent experiments were performed with three technical PCR replicates. The relative expression was quantified using the comparative CT method.

The mRNA produced from the duplication was further characterized at Mayo Clinic. Briefly, total RNA was extracted from LCLs of three carriers and two non-carrier controls with RNeasy Plus Mini kit (Qiagen) and the RNA was converted into cDNA with SuperScript III RT-PCR kit (Invitrogen). The carrier and non-carrier cDNA templates were amplified with PCR using primers in *RAD51C* exons 4 and 7 or at the exon 4-5 junction and intron 7. A human genomic DNA control was included to confirm that the PCR product was not from genomic DNA. The PCR products were analyzed on agarose gel.

#### **4.7 *IN SILICO* PREDICTION TOOLS AND ONLINE DATABASES (I, II, IV)**

The effect of the *RAD51D* c.576+1G>A mutation on splicing was evaluated with the Human Splicing Finder <sup>229</sup> and MaxEntScan <sup>230</sup> prediction tools (II). ClinVar <sup>231</sup> and HGMD <sup>232</sup> databases were searched for clinical significance interpretations for the *PTEN* and *TP53* missense mutations observed in Study IV. The Exome Aggregation Consortium (ExAC) and Genome Aggregation Databases (GnomAD) were searched for variant frequency information <sup>233-235</sup>.

#### **4.8 STATISTICAL METHODS (I, II, IV)**

Statistical analyses were performed with SPSS and R software. To study the association of the mutations with cancer risks, odds ratios with 95% confidence intervals were estimated with logistic regression and two-sided *p*-values were calculated using Fisher's exact test. Student's *t*-test was used to calculate the *p*-value for comparing the age at onset between mutation carriers and non-carriers and to evaluate the difference in the *RAD51C* expression. A *p*-value of <0.05 was considered statistically significant.

#### **4.9 ETHICAL ASPECTS**

The studies were approved by the Ethics Committee of Helsinki University Hospital and by the ethics committees of the other respective hospitals. All individuals participating in the study gave their informed consent.

## 5 RESULTS

### 5.1 IDENTIFICATION OF *RAD51C* AND *RAD51D* MUTATIONS (I, II)

One frameshift deletion c.93delG (p.Phe32SerfsX8) and one splicing mutation c.837+1G>A were identified in the Sanger sequencing of the *RAD51C* gene in 277 familial breast or ovarian cancer patients (Table 5). The c.93delG deletion was predicted to lead to a premature stop-codon in the first exon of the *RAD51C* gene, whereas the c.837+1G>A mutation disrupts the conserved 5' splice donor site of exon 5. We also detected one rare *RAD51C* missense variant c.790G>A, which was previously identified in breast and ovarian cancer families by Meindl *et al.* <sup>139</sup>.

In the sequencing of the *RAD51D* gene in 95 patients, one splicing mutation, c.576+1G>A, which abolishes the splice donor site in exon 6, was observed, whereas no pathogenic mutations were detected in *RAD54L* (Table 5). In addition, several polymorphisms were identified in all three genes.

### 5.2 FREQUENCIES OF *RAD51C* AND *RAD51D* POINT MUTATIONS (I, II, III)

#### 5.2.1 TRUNCATING *RAD51C* AND *RAD51D* MUTATIONS (I, II, III)

Genotyping of the identified protein-truncating *RAD51C* mutations c.93delG and c.837+1G>A and the *RAD51D* mutation c.576+1G>A in additional breast, ovarian, prostate, and colorectal cancer patients and population controls revealed six *RAD51C* and five *RAD51D* mutations among cases and two *RAD51C* and one *RAD51D* mutations among controls.

After combining the results of the initial sequencing and the subsequent genotyping, eight *RAD51C* mutations were detected among the patients in the Helsinki series (Table 6). All the mutation carriers had either a personal or family history of ovarian cancer. Each mutation was found in one breast-ovarian cancer family as well as in one ovarian cancer family but neither one was detected among breast-cancer-only families or among unselected breast cancer patients. Two c.93delG deletions and two c.837+1G>A splicing mutations were detected in the unselected ovarian cancer series with a combined frequency of 1% (OR = 6.31, 95% CI = 1.15-34.6,  $p = 0.033$  compared to population controls). The highest mutation frequency, 25%, was among ovarian cancer families ( $p = 0.0002$  compared to population controls). Compared to the unselected ovarian cancer patients, the mutations were significantly more frequent among the ovarian cancer families ( $p = 0.005$ ). The splicing mutation c.837+1G>A was not present among controls, but two of them carried the c.93delG deletion.

**Table 5.** Polymorphisms and mutations identified in the screening for the *RAD51C*, *RAD51D*, and *RAD54L* genes. Mutations selected for further genotyping are highlighted in **bold**.

DNA change	Protein change	rs-number	AA	Aa	aa	MAF	gnomAD-FIN
<b><i>RAD51C</i> (transcript NM_058216)</b>							
c.-26CT	-	rs12946397	175	82	20	22.0%	26.1%
<b>c.93delG</b>	<b>p.Phe32Serfs</b>	<b>rs730881942</b>	<b>275</b>	<b>2</b>	<b>0</b>	<b>0.36%</b>	<b>0.02%</b>
<b>c.790G&gt;A</b>	<b>p.Gly264Ser</b>	<b>rs147241704</b>	<b>276</b>	<b>1</b>	<b>0</b>	<b>0.18%</b>	<b>0.06%</b>
<b>c.837+1G&gt;A</b>	-	<b>rs760235677</b>	<b>275</b>	<b>2</b>	<b>0</b>	<b>0.36%</b>	<b>0.01%</b>
c.859A>G	p.Thr287Ala	rs28363317	276	1	0	0.18%	0.05%
c.904+34T>C	-	rs28363318	135	115	27	30.5%	30.0%
<b><i>RAD51D</i> (transcript NM_002878)</b>							
c.82+128C>T	-	rs28363258	93	2	0	1.05%	1.72%
c.234C>T	p.Ser78Ser	rs9901455	78	17	0	8.95%	11.1%
c.494G>A	p.Arg165Gln	rs4796033	71	23	1	13.2%	16.9%
<b>c.576+1G&gt;A</b>	-	<b>rs781161543</b>	<b>93</b>	<b>2</b>	<b>0</b>	<b>1.05%</b>	<b>0.004%</b>
c.903+53C>T	-	rs45496096	90	5	0	2.63%	1.40%
<b><i>RAD54L</i> (transcript NM_003579)</b>							
c.-112A>G	-	rs17102080	92	3	0	1.58%	1.52%
c.62A>G	p.Asp21Gly	rs28363192	93	2	0	1.05%	1.67%
c.408-157A>C	-	rs2295465	82	13	0	6.84%	10.5%
c.604C>T	p.Arg202Cys	rs28363218	94	1	0	0.53%	0.31%
c.767-57G>T	-	rs61239976	89	6	0	3.16%	-
c.1610+45C>T	-	rs118091259	93	2	0	1.05%	0.64%
c.1759C>T	p.Arg587Trp	rs150315374	90	5	0	2.63%	2.95%
c.2190C>T	p.Ala730Ala	rs1048771	83	12	0	6.32%	9.11%
c.2213G>A	p.Arg738His	rs28910278	94	1	0	0.53%	1.73%

DNA change = DNA-level variant coding according to HGVS nomenclature; Protein change = protein-level variant coding according to HGVS nomenclature; AA = number of common homozygotes; Aa = number of heterozygotes; aa = number of rare homozygotes; MAF = minor-allele frequency among the sequenced patients; gnomAD-FIN = minor-allele frequency among the Finnish population in gnomAD <sup>235</sup>.

**Table 6.** Frequencies of the protein-truncating *RAD51C* c.93delG and c.837+1G>A mutations in different patient groups.

	Total	wt (%)	mut (%)	p-value	OR (95% CI)
<b>Helsinki series</b>					
Population controls	1279	1277 (99.8%)	2 (0.2%)		
Familial BC	803	803 (100%)	0 (0.0%)	0.526	
Familial BC+OC	158	156 (98.7%)	2 (1.3%)	0.062	8.19 (1.14-58.5)
≥3 affected	96	94 (97.9%)	2 (2.1%)	0.026	13.6 (1.89-97.6)
2 affected	62	62 (100%)	0 (0.0%)	1	
Unselected BC	833	833 (100%)	0 (0.0%)	0.522	
Familial OC	8	6 (75.0%)	2 (25.0%)	0.0002	213 (25.6-1769)
Unselected OC	409	405 (99.0%)	4 (1.0%)	0.033	6.31 (1.15-34.6)
Any OC <sup>a</sup>	575	567 (98.6%)	8 (1.4%)	0.002	9.01 (1.91-42.6)
<b>Tampere series</b>					
Population controls	807	807 (100%)	0 (0.0%)		
Unselected BC	686	684 (99.7%)	2 (0.3%)	0.211	
<b>Prostate cancer</b>	1083	1083 (100%)	0 (0.0%)	0.503	
<b>Colorectal cancer</b>	802	802 (100%)	0 (0.0%)	0.526	

<sup>a</sup> Any OC includes patients with personal or family history of OC; BC = breast cancer, OC = ovarian cancer, wt = wild type, mut = carrier of c.93delG or c.837+1G>A mutation.

Altogether seven *RAD51D* c.576+1G>A mutations were identified among patients and one among controls in the Helsinki series after combining the two stages of mutation testing (Table 7). Five of the mutation carrier patients had a personal or family history of ovarian cancer (OR = 9.16, 95% CI = 1.07-78.6,  $p = 0.024$  compared to controls). The highest mutation frequency of 2.9% was among breast-ovarian cancer families with at least three affected family members (OR = 37.8, 95% CI = 3.90-367,  $p = 0.002$ ). In the unselected cohorts, one breast cancer patient and three ovarian cancer patients carried the mutation. The mutation-positive unselected breast cancer patient and one of the unselected ovarian cancer patients are also included in the breast-ovarian cancer families.

In the Tampere series, two *RAD51C* c.93delG mutations and one *RAD51D* c.576+1G>A mutation were detected among the breast cancer patients, whereas none of the mutations were observed in the controls (Tables 6 and 7). No mutations were detected among the prostate or colorectal cancer patients. The results suggest that the protein-truncating *RAD51C* and *RAD51D* mutations increase the risk of ovarian cancer, but not of breast, prostate, or colorectal cancer.

**Table 7.** Frequencies of the protein-truncating *RAD51D* c.576+1G>A mutation in different patient groups.

	Total	wt (%)	mut (%)	p-value	OR (95% CI)
<b>Helsinki series</b>					
Population controls	1287	1286 (99.9%)	1 (0.1%)		
Familial BC	819	818 (99.9%)	1 (0.1%)	1	1.57 (0.10-25.2)
Familial BC+OC	168	165 (98.2%)	3 (1.8%) <sup>a</sup>	0.006	23.4 (2.42-226)
≥3 affected	105	102 (97.1%)	3 (2.9%)	0.002	37.8 (3.90-367)
2 affected	63	63 (100%)	0 (0.0%)	1	
Unselected BC	849	848 (99.9%)	1 (0.1%) <sup>a</sup>	1	1.52 (0.09-24.3)
Familial OC	8	8 (100%)	0 (0.0%)	1	
Unselected OC	541	538 (99.4%)	3 (0.6%) <sup>a</sup>	0.080	7.17 (0.74-69.1)
Any OC <sup>b</sup>	707	702 (99.3%)	5 (0.7%)	0.024	9.16 (1.07-78.6)
<b>Tampere series</b>					
Population controls	815	815 (100%)	0 (0.0%)		
Unselected BC	691	690 (99.9%)	1 (0.1%)	0.459	
<b>Prostate cancer</b>	1094	1094 (100%)	0 (0.0%)	1	
<b>Colorectal cancer</b>	980	980 (100%)	0 (0.0%)	1	

<sup>a</sup> The mutation-positive unselected BC patient and one of the mutation-positive unselected OC patients also belong to the familial BC+OC cohort; <sup>b</sup> Any OC includes patients with personal or family history of OC; BC = breast cancer, OC = ovarian cancer, wt = wild type, mut = carrier of the c.576+1G>A mutation.

### 5.2.2 *RAD51C* c.790G>A MISSENSE VARIANT (I)

Given the suggestive association of the *RAD51C* c.790G>A missense variant with an increased risk among breast-ovarian cancer families in the study by Meindl *et al.*<sup>139</sup>, we further genotyped the variant in unselected and familial breast and ovarian cancer patients and population controls from the Helsinki series. After combining the initial screening and the additional genotyped patients, the c.790G>A variant was detected in altogether seven breast and four ovarian cancer cases as well as in three controls (Table 8). The frequency of the variant did not significantly differ from controls in any of the patient subgroups ( $p > 0.05$ ), suggesting that it does not increase the risk of breast or ovarian cancer.

**Table 8.** Frequencies of the *RAD51C* c.790G>A missense variant in different patient groups.

	Total	wt (%)	mut (%)	p-value	OR (95% CI)
Population controls	1279	1276 (99.8%)	3 (0.2%)		
Familial BC	803	800 (99.6%)	3 (0.4%)	0.682	1.60 (0.32-7.92)
≥3 affected	340	339 (99.7%)	1 (0.3%)	1	1.25 (0.13-12.1)
2 affected	463	461 (99.6%)	2 (0.4%)	0.613	1.85 (0.31-11.1)
Familial BC+OC	158	157 (99.4%)	1 (0.6%)	0.373	2.71 (0.23-26.2)
≥3 affected	96	96 (100%)	0 (0.0%)	1	
2 affected	62	61 (98.4%)	1 (1.6%)	0.173	6.97 (0.71-68.0)
Unselected BC	833	829 (99.5%)	4 (0.5%)	0.444	2.05 (0.46-9.19)
Familial OC	8	8 (100%)	0 (0.0%)	1	
Unselected OC	409	405 (99.0%)	4 (1.0%)	0.063	4.20 (0.94-18.8)
Any OC <sup>a</sup>	575	570 (99.1%)	5 (0.9%)	0.117	3.73 (0.89-15.7)

<sup>a</sup> Any OC includes patients with personal or family history of OC; BC = breast cancer, OC = ovarian cancer, wt = wild type, mut = carrier of the c.790>A variant.

### 5.3 EFFECTS OF THE *RAD51C* AND *RAD51D* SPLICING MUTATIONS (I, II)

We evaluated the effect of the *RAD51C* c.837+1G>A mutation on splicing in RNA samples of two carriers. Amplification of the cDNA with primers specific for *RAD51C* exons 3 and 8 produced three different-sized bands for the heterozygous mutation carriers and one band for a mutation-negative control sample on agarose gel (Study I: Figure 2). Sequencing of the PCR products revealed in the mutation-positive samples one mutant transcript lacking exons 4 and 5 and another mutant transcript lacking exon 5. The deletion of exons 4 and 5 disrupts the reading frame and leads to a premature stop-codon (p.Glu191GlyfsX12), whereas the deletion of exon 5 alone does not affect the reading frame (p.Val236\_Ala279del). In the control sample, only the normal wild type transcript was present.

The online tools Human Splicing Finder and MaxEntScan predicted that the *RAD51D* c.576+1G>A mutation disrupts the 5'donor splice site of exon 6, which may lead to a skipping over of adjacent exon(s), the inclusion of intron(s), or the use of cryptic splice sites, and ultimately to a truncated protein.

## 5.4 *RAD51C* AND *RAD51D* FAMILIES AND HAPLOTYPE ANALYSIS (I, II)

Additional DNA samples from relatives were available for genotyping from three *RAD51C* and three *RAD51D* families in the Helsinki series. All the tested patients with invasive breast or ovarian cancer were mutation carriers.

In the *RAD51C* c.837+1G>A breast-ovarian cancer family (Family 1), the mutation was observed in the breast cancer index patient and in her mother affected with breast cancer, while the healthy sister and daughter were non-carriers (Figure 2A). Several other cancer types were observed in the family, such as ovarian, colorectal, uterine, brain, and prostate cancer, but no samples were available for genotyping. The c.837+1G>A was also observed in an ovarian cancer index patient whose mother was affected with ovarian cancer, but the DNA sample was only available from the index patient (Family 2).

Segregation of the *RAD51C* c.93delG mutation was studied in one breast-ovarian cancer family and in one ovarian cancer family. In the breast-ovarian cancer family (Family 3), all the studied relatives were carriers. These included one breast cancer and one breast-ovarian cancer patient, two relatives with skin cancer, two healthy males, and the breast cancer index patient herself. In the ovarian cancer family (Family 4), the healthy son of the index patient as well as the sister and her daughter were mutation carriers.

The *RAD51D* c.576+1G>A mutation was observed in one breast cancer family (Family 5) where the index patient, her grandmother, and grandmother's sister were affected with breast cancer, but the DNA sample was only available from the index patient (Figure 2B). The c.576+1G>A positive unselected ovarian cancer patient, who also belonged to the familial cohort, had a mutation-positive mother who was affected with ovarian cancer (Family 6). The index patient's healthy son and daughter were also mutation carriers, whereas no sample was available from the maternal aunt, who was affected with breast and gallbladder cancers. For the unselected breast cancer patient with the *RAD51D* mutation, samples were available from four healthy sisters, of whom two were non-carriers and two carried the mutation while no samples were available from relatives affected with breast or ovarian cancer (Family 7). In the third c.576+1G>A positive breast-ovarian cancer family, the index patient, her breast-cancer-affected mother and healthy son and daughter carried the mutation (Family 8). The index patient's sister, who had *in situ* breast cancer, did not carry the mutation, whereas no samples were available from the ovarian cancer patients.

To investigate whether the identified *RAD51C* and *RAD51D* mutations represent founder mutations in the Finnish population, seven and eight SNPs within and adjacent to the *RAD51C* and *RAD51D* genes, respectively, were screened in family members from the mutation carrier families. Carriers of each mutation were found to share a common haplotype, which indicates a common ancestry for the families and a founder effect for the mutations.



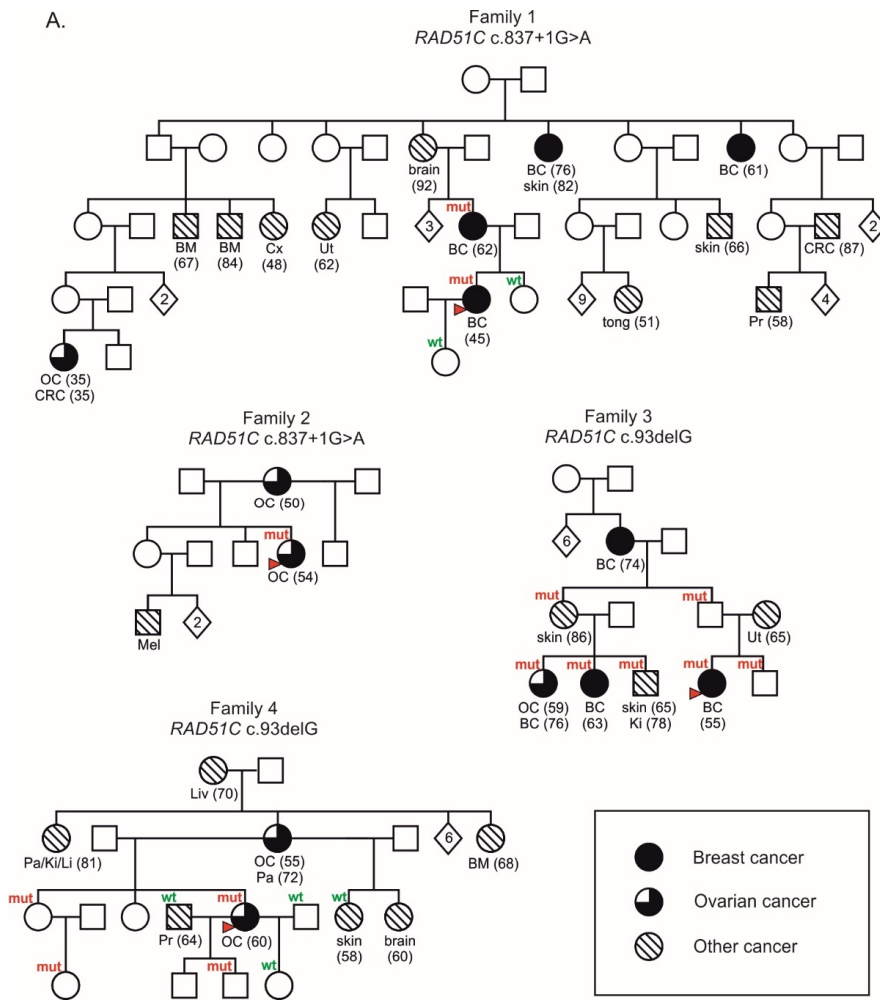

**Figure 2** Pedigrees of the *RAD51C* and *RAD51D* mutation carrier families. **A**, *RAD51C* c.837+1G>A and c.93delG families. **B**, *RAD51D* c.576+1G>A families. The mutation status is denoted above and the type of cancer below each individual with the age at onset in parentheses. \*Same individual. **Mut** = mutation-positive, **wt** = wild type, BC = breast cancer, BM = bone marrow cancer, Cx = cervical cancer, Ut = uterine cancer, CRC = colorectal cancer, OC = ovarian cancer, Pr = prostate cancer, Mel = melanoma, Pa = pancreatic cancer, Ki = kidney cancer, Li = liver cancer, Ga = gallbladder cancer.

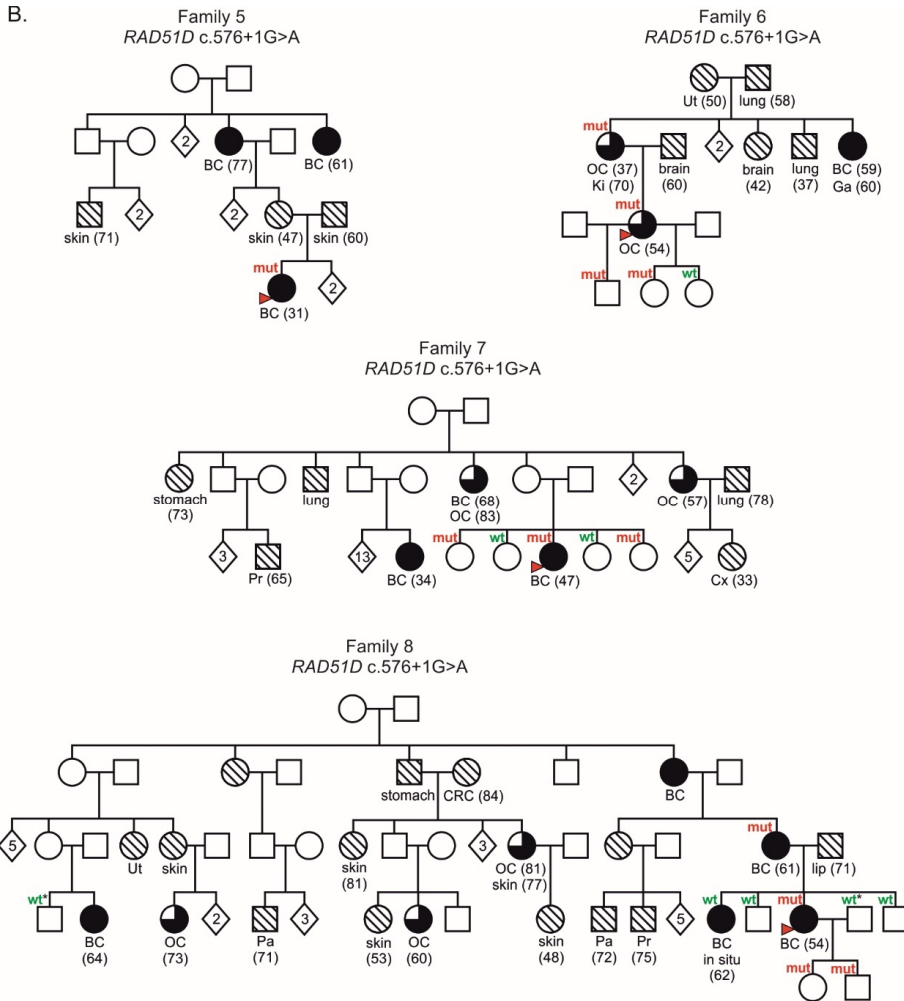

## 5.5 CLINICAL CHARACTERISTICS OF *RAD51C* AND *RAD51D* MUTATION CARRIERS (I, II)

The clinical and pathological characteristics of the mutation carriers from the Helsinki series are presented in Table 9. More information has been obtained for the *RAD51D* mutation carriers since the publication of the article. The mean age at first breast cancer diagnosis was 60.1 years among the five *RAD51C* mutation carriers and 55.5 among mutation-negative patients ( $p = 0.403$ ), while the mean age at ovarian cancer diagnosis was 57.7 years for the seven carriers and 54.8 for the non-carriers ( $p = 0.589$ ). Among the four *RAD51D* mutation carriers, the mean age at first breast cancer diagnosis was 48.1 years, compared to 55.5 years among the non-carriers ( $p = 0.234$ ). The mean age at ovarian cancer diagnosis

was 59.1 years for the four carriers and 54.9 years for the non-carriers ( $p = 0.525$ ).

**Table 9.** *Clinical and histopathological characteristics of the RAD51C and RAD51D mutation carriers and tumors.*

Cancer	LOH	dg-age	T	N	M	Grade	Stage	Tumor histology	ER	PR	HER2
<b>RAD51C c.837+1G&gt;A</b>											
Breast	no	61.9	1	0	0	NA	1	Ductal	NA	NA	NA
Breast	yes	45.0	2	0	0	3	2A	Ductal	neg	neg	neg
Ovary	yes	53	NA	NA	1	3	3C	Serous	NA	NA	NA
Ovary	yes	68	NA	1	1	2	3C	Serous	NA	NA	NA
Ovary	NA	50	NA	0	0	2	1A	Endometrioid	NA	NA	NA
<b>RAD51C c.93delG</b>											
Breast	yes	54.7	1	0	0	3	1	Ductal	neg	neg	pos
Breast	NA	63.1	1	0	0	3	NA	Lobular	NA	NA	NA
Breast <sup>a</sup>	NA	76	1	0	0	2	1	Lobular	pos	neg	neg
Ovary <sup>a</sup>	yes	59	NA	NA	1	NA	1C	Serous	NA	NA	NA
Ovary	yes	60	NA	0	1	1	3C	Serous	NA	NA	NA
Ovary	yes	60	NA	1	1	3	3C	Serous	NA	NA	NA
Ovary	yes	54	NA	1	1	3	4	Serous	NA	NA	NA
<b>RAD51D c.576+1G&gt;A</b>											
Breast	NA	30.8	1	0	0	3	1	Ductal	neg	neg	neg
Breast	no	53.8	2	1	0	2	2B	Ductal	pos	pos	neg
Breast	NA	61.3	NA	NA	NA	3	NA	Ductal	NA	NA	neg
Breast	NA	46.5	1	0	0	1	1	Ductal	NA	NA	NA
Ovary	yes	67	NA	NA	1	3	NA	Serous	NA	NA	NA
Ovary	yes	79	NA	NA	1	NA	NA	NA	NA	NA	NA
Ovary	yes	53.6	NA	NA	NA	3	NA	Serous	NA	NA	NA
Ovary	NA	37	NA	NA	NA	NA	NA	Serous	NA	NA	NA

<sup>a</sup> These tumors are from the same individual; dg-age = age at diagnosis, neg = negative, pos = positive, NA = not applicable.

Three of the *RAD51C* breast tumors were of ductal histology and two were lobular. All four of the *RAD51D* breast tumors were ductal. The ovarian tumors were serous except for one endometrioid tumor from *RAD51C* c.837+1G>A carrier. The *RAD51C* breast tumors were of high grade, while the grade for *RAD51D* breast tumors varied; the ovarian tumors were mainly of high grade.

Information on hormone receptor and HER2 status was sparse; one *RAD51C* c.837+1G>A and one *RAD51D* c.576+1G>A breast tumor was triple-negative. LOH analysis revealed reduction of the wild-type allele for all studied ovarian tumors, whereas the one studied *RAD51D* breast tumor and one out of three *RAD51C* breast tumors did not show LOH.

## 5.6 GENE-PANEL SEQUENCING (IV)

### 5.6.1 MUTATIONS IDENTIFIED IN GENE-PANEL SEQUENCING

In the gene-panel testing, 12 different pathogenic mutations were identified in 18 out of 95 patients (19%) (Tables 10 and 11). Protein-truncating *BRCA1* mutations were detected in five patients (5.3%) and *BRCA2* mutations in three patients (3.2%). The *CHEK2* c.1100delC mutation was detected in seven patients (7.4%). Two of the c.1100delC-positive patients were compound heterozygotes and also carried the *CHEK2* splicing mutation c.444+1G>A. Thus, altogether 20 mutations were detected. All six of the female c.1100delC carriers were diagnosed with breast cancer at an early age (range 22–39 years), while the seventh carrier was a male patient affected with breast and thyroid cancer. Two of the *BRCA1*-positive patients and one *CHEK2*-positive patient also carried the *CHEK2* low-penetrance missense variant c.470T>C p.Ile157Thr (I157T). In total, the c.470T>C variant was detected in six patients. Of the 20 patients from families previously negative for *BRCA1/2* mutations, one harbored the *CHEK2* c.1100delC and c.444+1G>A mutations and one had a *BRCA1* nonsense mutation that was not covered by the previous founder mutation screening.

One pathogenic missense mutation was observed in each of the *PTEN* and *TP53* genes. The identified *PTEN* and *TP53* missenses are classified as pathogenic mutations in the ClinVar (RCV000169787.2 and RCV000129010.2) and HGMD databases and neither is observed in the ExAC database. The *PTEN* mutation was observed in a woman diagnosed with breast cancer at the age of 39. Her mother had been diagnosed with breast cancer at the age of 63 and maternal aunt with synovial sarcoma at the age of 43 and breast cancer at the age of 45. More careful medical inspection after the genetic test result revealed a fibroma, goiter and several trichilemmomas, but a normal head circumference. The *TP53* mutation was observed in a woman diagnosed with bifocal breast cancer at the age of 29. Her maternal grandfather's sister had breast cancer at an old age and maternal aunt colon cancer at the age of 55. In *RAD51C*, the splicing mutation c.837+1G>A identified in Study I was observed in a woman diagnosed with ovarian and uterine cancers at the age of 40. No deleterious mutations in *RAD51D*, *STK11*, or *PALB2* were detected.

**Table 10.** Pathogenic mutations observed in the gene-panel testing and clinical and histopathological features of the carrier tumors.

Mutation	Cancer (dg-age)	Histology <sup>a</sup>	Grade	ER	PR	HER2
<b>BRCA1 (transcript NM_007294.3)</b>						
c.3626delT	BC (34)	ductal	NA	neg	NA	NA
c.3626delT <sup>b</sup>	BC bilat (43+48)	ductal	3	neg	neg	neg
c.4656C>A p.Tyr1552Ter <sup>b</sup>	BC (52), OC (58)	ductal	1	pos	pos	NA
c.5278-1G>C	BC (31)	ductal	NA	neg	neg	neg
c.4186-1787_4357+4122dup (ex13 duplication <sup>c</sup> )	BC bilat (54+54)	ductal	3	neg	neg	neg
<b>BRCA2 (transcript NM_000059.3)</b>						
c.1286T>G p.Leu429Ter	BC (38)	ductal	3	neg	neg	pos
c.7480C>T p.Arg2494Ter	BC (60), OC (54)	ductal	NA	pos	neg	neg
c.8314G>T p.Glu2772Ter	BC (26)	ductal	2-3	pos	pos	pos
<b>CHEK2 (transcript NM_007194.3)</b>						
c.1100delC <sup>b</sup>	BC bifocal (22)	ductal	3	pos	pos	pos
c.1100delC	BC (34)	ductal	3	pos	neg	neg
c.1100delC	BC (25)	ductal	2	pos	pos	pos
c.1100delC	BC (26)	ductal	2	pos	pos	pos
c.1100delC	BC (30)	ductal	3	pos	neg	pos
c.1100delC; c.444+1G>A	BC bilat (39+69)	ductal	2	NA	NA	NA
c.1100delC; c.444+1G>A	MBC (46), thyroid (28)	ductal	2	pos	pos	neg
<b>PTEN (transcript NM_000314.6)</b>						
c.70G>T p.Asp24Tyr	BC (39)	duct et lobular	3	pos	pos	neg
<b>TP53 (transcript NM_000546.5)</b>						
c.844C>G p.Arg282Gly	BC bifocal (29)	ductal	NA	pos/neg	pos/neg	pos/pos
<b>RAD51C (transcript NM_058216.2)</b>						
c.837+1G>A	OC (40), uterine (40)	serous	3	pos	NA	NA

<sup>a</sup> Histology, grade, and ER, PR, and HER2 status are denoted for the first breast tumor; for the patient without breast cancer, the information is given for the ovarian tumor. <sup>b</sup> Patient also carries the *CHEK2* c.470T>C p.Ile157Thr low-penetrance variant; <sup>c</sup> exon numbering based on U14680.1 transcript; dg-age = age at diagnosis, BC = breast cancer, NA = not applicable, neg = negative, bilat = bilateral, OC = ovarian cancer, pos = positive, MBC = male breast cancer.

**Table 11.** Number of mutation-positive patients in different ascertainment groups.

Ascertainment criteria	Mutation carriers	Mutated genes (number of mutation carriers)
BC family $\geq 3$ affected	6 of 35 (17%)	<i>BRCA1</i> (2), <i>BRCA2</i> (1), <i>CHEK2</i> (2), <i>PTEN</i> (1)
BC only ( $\geq 3$ affected)	4 of 20 (20%)	<i>BRCA1</i> (1), <i>CHEK2</i> (2), <i>PTEN</i> (1)
BC+OC ( $\geq 3$ affected)	2 of 15 (13%)	<i>BRCA1</i> (1), <i>BRCA2</i> (1)
BC family 2 affected	5 of 23 (22%)	<i>BRCA1</i> (1), <i>BRCA2</i> (1), <i>CHEK2</i> (2), <i>RAD51C</i> (1)
BC only (2 affected)	3 of 14 (21%)	<i>BRCA2</i> (1), <i>CHEK2</i> (2)
BC+OC (2 affected)	2 of 9 (22%)	<i>BRCA1</i> (1), <i>RAD51C</i> (1)
early-onset BC	4 of 18 (22%)	<i>BRCA2</i> (1), <i>CHEK2</i> (2), <i>TP53</i> (1)
TNBC	2 of 10 (20%)	<i>BRCA1</i> (2)
MBC	1 of 5 (20%)	<i>CHEK2</i> (1)
other <sup>a</sup>	0 of 4 (0%)	-
All	18 of 95 (19%)	<i>BRCA1</i> (5), <i>BRCA2</i> (3), <i>CHEK2</i> (7), <i>PTEN</i> (1), <i>TP53</i> (1), <i>RAD51C</i> (1)

<sup>a</sup> Includes three breast-ovarian cancer patients and one breast-colorectal cancer patient with a family history of other cancers; BC = breast cancer, OC = ovarian cancer, MBC = male breast cancer.

Among the 20 identified mutations was one CNV, which was a known *BRCA1* exon 13 duplication accounting for 20% of the all the observed mutations in *BRCA1* and 5% of all the observed pathogenic mutations in any gene. In addition to the pathogenic mutations detected in 18 patients, a novel heterozygous *RAD51C* duplication was identified in the CNV analysis. Together, the *BRCA1* and *RAD51C* duplications accounted for 9.5% of all the observed pathogenic or potentially pathogenic mutations. The *RAD51C* duplication was identified in a woman diagnosed with breast cancer at the age of 40 and basal cell carcinoma at the age of 45. She had previously tested negative for *BRCA1/2* mutations. According to the CNV analysis, the duplication starts upstream of the *RAD51C* gene around chromosomal position chr17:56,738,600 and ends in the *RAD51C* intron 7 around position chr17: 56,802,672. With Sanger sequencing the mutation was characterized as a 64 179 base-pair (bp) long duplication (chr17:56,738,493-56,802,671), starting 31 512 bp upstream of the *RAD51C* start codon and extending to *RAD51C* intron 7 with a 10 bp insertion CTTTTGTGAG between the two copies (c.-31512\_965+1210dup{insCTTTTGTGAG}). Thus, there is an extra copy of *RAD51C* exons 1–7 located 31 kb upstream of the full-length gene (Study IV: Figure 1).

### 5.6.2 GENOTYPING OF THE *RAD51C* DUPLICATION

The duplication carrier had three sisters affected with breast cancer. Ovarian cancer as well as various other cancer types, such as Hodgkin lymphoma,

colorectal cancer, and prostate cancer, were observed among distant relatives. Two of the breast-cancer-affected sisters were duplication carriers, whereas no duplications were observed in the three tested healthy women (Figure 3).

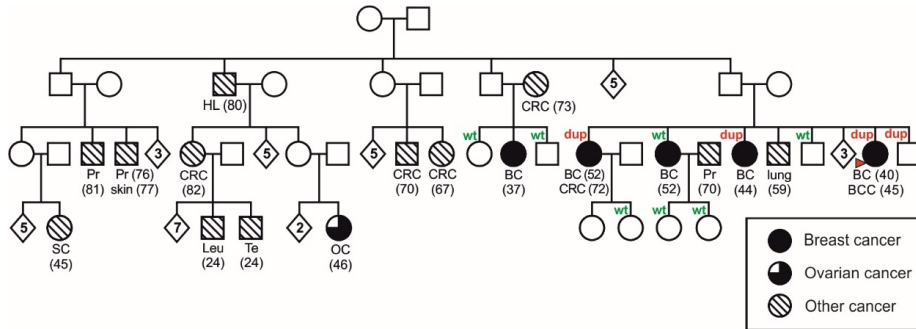

**Figure 3** Pedigree of the *RAD51C* duplication family. The mutation status is denoted above and the type of cancer below each individual with the age at onset in parentheses. Dup = duplication carrier, wt = non-carrier, SC = spinal cord, Pr = prostate cancer, HL = Hodgkin's lymphoma, CRC = colorectal cancer, Leu = leukemia, Te = testicular cancer, OC = ovarian cancer, BC = breast cancer, BCC = basal cell carcinoma, dup = duplication.

Genotyping of the duplication in familial and unselected breast and ovarian cancer patients and population controls revealed seven duplication carriers among cases and none among controls. Three carriers were identified among unselected breast cancer patients, with one of them also affected with ovarian cancer, and two were identified among unselected ovarian cancer patients. No additional carriers were identified among breast-ovarian cancer families, whereas two duplications were observed among breast-cancer-only families. After combining the 46 familial *BRCA1/2*-negative breast or ovarian cancer patients from the gene-panel testing with the genotyped patients, eight duplication carriers were identified and half of them had a personal or family history of ovarian cancer. All the duplication carriers were negative for the *RAD51C* c.93delG and c.837+1G>A mutations. The frequency of the duplication was significantly higher among ovarian cancer cases (0.5%) than among population controls (0.0%) ( $p = 0.032$ ) (Table 12).

Two of the breast tumors from duplication carriers were of ductal histology, two were lobular and two were tubular. Two of the ovarian tumors were of mucinous subtype whereas the third one was endometrioid.

**Table 12.** Frequencies of the *RAD51C* duplication in different patient groups.

Patient group	Total	Wt (%)	Dup (%)	p-value
<b>Population controls</b>	1273	1273 (100.0%)	0 (0.0%)	
<b>All BC</b>	2533	2527 (99.8%)	6 (0.2%)	0.188
Unselected BC	1729	1726 (99.8%)	3 (0.2%) <sup>a</sup>	0.267
Familial BC	973	971 (99.8%)	2 (0.2%)	0.188
Familial BC+OC	214	213 (99.5%)	1 (0.5%)	0.144
<b>All OC<sup>b</sup></b>	590	587 (99.5%)	3 (0.5%) <sup>a</sup>	<b>0.032</b>
Unselected OC	553	551 (99.6%)	2 (0.4%)	0.092
Familial OC	8	8 (100.0%)	0 (0.0%)	1
<b>Any OC<sup>c</sup></b>	782	778 (99.5%)	4 (0.5%)	<b>0.021</b>

<sup>a</sup> One of the duplication-positive unselected breast cancer patients was affected by both breast and ovarian cancer and is also included in the All OC patient group;

<sup>b</sup> Unselected and familial OC patients as well as BC+OC patients from the unselected and familial BC cohorts are included in the All OC patient group; <sup>c</sup> Any OC includes all patients with personal or family history of OC; wt = wild type, dup = duplication carrier, BC = breast cancer, OC = ovarian cancer.

### 5.6.3 *RAD51C* EXPRESSION

The *RAD51C* RNA expression was measured in LCLs of three duplication carriers and two non-carriers in order to study whether the duplication is transcribed into mRNA and whether it affects the expression level of *RAD51C*. When the *RAD51C* expression was measured with a probe binding to the boundary of *RAD51C* exons 1-2 and *ACTB* was used as an endogenous control, two of the carriers showed significantly increased *RAD51C* expression compared to the non-carrier control sample (RQ = 1.52,  $p = 0.020$  and RQ = 1.68,  $p = 0.013$ ) with the third carrier showing a 1.23-fold increase ( $p = 0.141$ ) (Table 13; Study IV: Figure 2). On average, the three carriers showed 1.48-fold increased *RAD51C* expression ( $p = 0.074$  compared to the two non-carriers). When the expression was measured with the *RAD51C* exons 8-9 probe, residing outside of the duplicated area, the expression levels were comparable in the carriers and non-carriers. Finally, when the expression was measured with the *RAD51C* exons 1-2 probe and the exons 8-9 probe was used as a control, the duplication carriers showed 1.21 to 1.66-fold increased expression, one of them with significantly increased expression compared to the control ( $p = 0.006$ ). On average, the three carriers showed 1.42-fold increased expression of the *RAD51C* exons 1-2 ( $p = 0.084$  compared to the two non-carriers). The observed fold-change suggests that a stable aberrant mRNA may be produced and is concordant with the heterozygous carriers having three copies of *RAD51C* exons 1-7 and two copies of exons 8-9 in their genomes.



**Table 13.** Expression of *RAD51C* ex1-2 and ex8-9 normalized to *ACTB* and expression of *RAD51C* ex1-2 normalized to *RAD51c* ex8-9 in three duplication carriers (Dup 1-3) and one non-carrier (wt) compared to a healthy non-carrier (Control).

Samples	RAD51C ex1-2 vs ACTB			RAD51C ex8-9 vs ACTB			RAD51C ex1-2 vs ex8-9		
	RQ	SEM	p-value	RQ	SEM	p-value	RQ	SEM	p-value
Dup 1	1.23	0.09	0.141	0.89	0.16	0.514	1.39	0.16	0.068
Dup 2	1.68	0.15	<b>0.013</b>	1.01	0.15	0.941	1.66	0.10	<b>0.006</b>
Dup 3	1.52	0.11	<b>0.020</b>	1.26	0.17	0.245	1.21	0.10	0.172
wt	1.10	0.16	0.564	1.03	0.16	0.865	1.07	0.07	0.589
Control	1	0.15		1	0.20		1	0.14	

RQ = relative quantification; SEM = standard error of the mean; dup = duplication carrier; wt = wild type

The mRNA produced from the duplication was further characterized in RNA samples of three duplication carrier and two wild-type control LCLs. The duplication spans the first seven exons that encode amino acids 1–322 in the wild-type *RAD51C* protein. If the translation continues into intron 7, a new stop codon would be encountered after 18 amino acids, p.(Phe323SerfsTer18). Consistent with this, PCR using primers in exons 4 and 7 produced an expected 300 bp long product in both the duplication carriers and controls, but primers at the exon 4-5 junction and in intron 7 produced a novel 663 bp long product observed only in the carriers (Study IV: Figure S2).

## 6 DISCUSSION

### 6.1 GERMLINE MUTATIONS IN *RAD51C* AND *RAD51D* INCREASE OVARIAN CANCER RISK

Two pathogenic, recurrent mutations in the *RAD51C* gene and one in the *RAD51D* gene were identified among Finnish breast and ovarian cancer patients in this study, but no *RAD54L* mutations were observed. Although the sample set was small, the results suggest that the *RAD54L* gene does not substantially contribute to breast or ovarian cancer predisposition in the Finnish population. To date, no conflicting reports have been published in the literature. In a targeted sequencing study including 12 DNA repair genes, Dicks *et al.* detected only five *RAD54L* germline mutations among over 4 500 ovarian cancer patients with a mutation frequency similar to that of healthy controls<sup>236</sup>. Taken together, it is unlikely that *RAD54L* plays a significant role in breast or ovarian cancer predisposition, although rare mutations or small risk effects cannot be ruled out.

The *RAD51C* mutations were detected only in patients with personal or family history of ovarian cancer, but not among breast-cancer-only families or unselected breast cancer patients in the Helsinki series. This is consistent with the initial report by Meindl *et al.* where *RAD51C* was proposed as a breast and ovarian cancer susceptibility gene<sup>139</sup>. Our results, however, indicate that *RAD51C* mutations primarily predispose to ovarian cancer, but are not associated with breast cancer in the absence of ovarian cancer family history, suggesting *RAD51C* as the first moderate-penetrance ovarian cancer susceptibility gene. While most of the early papers published before Study I did not identify pathogenic mutations among breast or ovarian cancer patients<sup>147-150</sup>, several studies published since have reported rare *RAD51C* mutations, mainly among breast-ovarian or ovarian-cancer-only families or unselected ovarian cancer patients<sup>121, 237-248</sup>. As the mutations are very rare, only a few studies have been able to estimate the associated cancer risks, whereas the recurrent founder mutations observed in this study allowed us to perform case-control analyses. The OR of 6.3 observed here among unselected ovarian cancer patients suggests a moderate to high risk of ovarian cancer for the mutation carriers. Loveday *et al.* and Song *et al.* later confirmed the association with ovarian cancer, with estimated relative risks between 5.2 and 5.9 (Table 14), in line with our results<sup>121, 247</sup>. For the serous subtype, Song *et al.* estimated a higher OR of 7.4 (95% CI = 1.6-35)<sup>247</sup>.

*RAD51D* was originally established as an ovarian cancer susceptibility gene by Loveday *et al.*, with pathogenic mutations conferring a 6.3-fold relative risk of ovarian cancer, but no significant increase in breast cancer risk<sup>122</sup>. Consistently, we observed an elevated frequency of the *RAD51D* mutation among breast-ovarian cancer families and among patients with personal or family history of ovarian cancer, while the mutation frequency among unselected breast cancer patients was not significantly higher than among population controls. Since then,

rare *RAD51D* mutations have been observed in several follow-up studies among ovarian cancer patients and breast-ovarian cancer families, but not among breast-cancer-only families<sup>246, 247, 249-253</sup>. As with *RAD51C*, only a few studies have estimated the cancer risks associated with *RAD51D* mutations. The OR of 7.2 observed in this study among unselected ovarian cancer patients, although not reaching statistical significance, suggests an increased risk of ovarian cancer and is in line with the risk estimated by Loveday *et al.*<sup>122</sup>. Similar results were obtained by Song *et al.*, albeit with a higher OR of 12 both for all ovarian cancer subtypes (Table 14) and for the serous subtype (OR = 12, 95% CI = 1.5-97)<sup>247</sup>. To date, the study by Song *et al.* remains the largest population-based case-control study on the *RAD51C* and *RAD51D* genes, as it includes 3 429 ovarian cancer cases and 2 772 controls<sup>247</sup>. Both for the *RAD51C* and for the *RAD51D* mutation carriers, they estimated an average cumulative ovarian cancer risk of 1.3% by age 50, whereas the cumulative risk by age 70 was 5.2% for *RAD51C* carriers and 12% for *RAD51D* carriers.

**Table 14.** *Reported ovarian cancer risk estimates for RAD51C and RAD51D mutation carriers.*

Study <sup>ref</sup>	Cases	Controls	<i>RAD51C</i> relative risk	<i>RAD51D</i> relative risk
Loveday <i>et al.</i> 2011 <sup>122</sup>	911	1 060	NA	<b>6.3</b> (95% CI = 2.9-14, $p = 4.8 \times 10^{-6}$ )
Loveday <i>et al.</i> 2012 <sup>121</sup>	1 404	1 156	<b>5.9</b> (95% CI = 2.9-12, $p = 7.65 \times 10^{-7}$ )	NA
Song <i>et al.</i> 2015 <sup>247</sup>	3 429	2 772	<b>5.2</b> (95% CI = 1.1-24, $p = 0.035$ )	<b>12</b> (95% CI = 1.5-90, $p = 0.019$ )
Norquist <i>et al.</i> 2016 <sup>254</sup>	1 915	4 300 <sup>a</sup>	<b>16</b> (95% CI = 1.9-128, $p = 0.002$ )	<b>9</b> (95% CI = 1.9-43, $p = 0.002$ )
		36 276 <sup>b</sup>	<b>3.4</b> (95% CI = 1.5-7.9, $p = 0.005$ )	<b>11</b> (95% CI = 4.6-26, $p < 0.001$ )
Lilyquist <i>et al.</i> 2017 <sup>255</sup>	7 768	~25 000 <sup>c</sup>	<b>5.1</b> (95% CI = 3.7-6.9, $p = 1.1 \times 10^{-16}$ )	<b>6.3</b> (95% CI = 3.2-11, $p = 4.4 \times 10^{-6}$ )

<sup>a</sup> ESP European American reference controls; <sup>b</sup> ExAC reference controls; <sup>c</sup> ExAC non-Finnish European non-TCGA reference controls; ref = reference

The association of *RAD51C* and *RAD51D* germline mutations with ovarian cancer has been further confirmed in two large gene-panel studies where the mutation frequencies in ovarian cancer patients were compared to the frequencies in publicly available reference controls<sup>254, 255</sup>. Norquist *et al.* analyzed 1 915 unselected ovarian cancer patients compared to controls from the NHLBI GO

Exome Sequencing Project (ESP) and from ExAC <sup>254</sup>. The ORs ranged between 3.4 and 16 for *RAD51C* mutations and 9-11 for *RAD51D* mutations (Table 14). Lilyquist *et al.* analyzed 10 203 ovarian cancer cases referred for clinical testing and estimated the risks based on 7 768 patients of European ancestry compared to ExAC non-TCGA controls <sup>255</sup>. *RAD51C* mutations were associated with a 5.1-fold and *RAD51D* mutations with a 6.3-fold increased risk of ovarian cancer. Although the large size of the latter study allows more precise risk estimates, the study population was enriched for patients with a positive family history, which can lead to an overestimation of risk. However, the risk estimates are similar to those obtained by us, Loveday *et al.*, and Song *et al.* <sup>121, 122, 247</sup>.

## 6.2 *RAD51C* AND *RAD51D* MUTATIONS IN BREAST CANCER PREDISPOSITION

While our results together with the data from other studies strongly indicate that pathogenic mutations in *RAD51C* and *RAD51D* increase the risk of ovarian cancer, the association with breast cancer risk has been more controversial. The absence of *RAD51C* mutations among breast-cancer-only families and unselected breast cancer patients from Helsinki indicates that *RAD51C* mutations are not associated with an increased risk of breast cancer. Concordantly, while two *RAD51C* mutations were detected in the Tampere unselected breast cancer series, the frequency did not differ from that among controls. The *RAD51D* mutation was detected once among breast-cancer-only families and once in the Helsinki and Tampere unselected breast cancer series; however, these frequencies were similar to those of the controls. The presence of multiple breast cancer cases in some of the mutation carrier families suggests that other susceptibility alleles may be segregating and confer an increased risk of breast cancer, or potentially modify the effect of the *RAD51C* or *RAD51D* mutations. Consistent with our results, Loveday *et al.* did not observe a significant association with breast cancer for either gene in modified segregation analyses <sup>121, 122</sup>. However, while there was no evidence of association for *RAD51C* with breast cancer (RR = 0.91, 95% CI = 0.45–1.86,  $p = 0.8$ ), the confidence intervals for *RAD51D* were wider (RR = 1.32, 95% CI = 0.59–2.96,  $p = 0.50$ ).

Recently, the breast cancer association of *RAD51C* and *RAD51D* mutations have been studied in large gene-panel studies. Couch *et al.* observed six *RAD51C* and seven *RAD51D* mutations among 1 824 unselected TNBC patients <sup>256</sup>. Interestingly, none of the *RAD51C* mutation carriers and only one *RAD51D* carrier had a family history of ovarian cancer. Buys *et al.* identified 53 *RAD51C* and 19 *RAD51D* mutations among 35 409 breast cancer patients who underwent clinical genetic testing <sup>257</sup>. The *RAD51C* mutations were significantly enriched in women with TNBC compared to women with other breast cancer subtypes (0.4% versus 0.1%;  $p < 0.001$ ). In contrast, only one of the five *RAD51C* breast tumors and one of the four *RAD51D* tumors in our study were triple-negative. Moreover, as

neither of these studies performed case-control comparisons, no conclusions about the associated breast cancer risks can be drawn. In the largest study thus far, Couch *et al.* detected *RAD51C* mutations in 0.09% and *RAD51D* mutations in 0.07% of 38 326 breast cancer patients undergoing clinical genetic testing<sup>258</sup>. Compared to ExAC non-Finnish European controls, the *RAD51C* mutations were not associated with an increased risk of breast cancer (OR = 0.78, 95% CI = 0.47-1.37,  $p = 0.43$ ), but rather were associated with a family history of ovarian cancer (OR = 2.89, 95% CI = 1.26-6.45,  $p = 0.01$ ). Pathogenic variants in *RAD51D*, on the other hand, were associated with a moderate risk of breast cancer (OR = 3.07, 95% CI = 1.21-7.88,  $p = 0.01$ ). Even though the use of non-matched reference controls is not ideal, the very large size of this study allowed estimation of the breast cancer risk associated with these rare mutations. Taken together, our results together with other studies indicate that *RAD51C* mutations do not increase breast cancer risk, although the role of *RAD51C* in specific breast cancer subtypes, such as TNBC, cannot be fully excluded. *RAD51D* mutations, however, may be associated with a moderate risk of breast cancer, but further research is required to confirm and better define the associated risk.

### **6.3 *RAD51C* AND *RAD51D* MUTATION CARRIER FAMILIES AND OVARIAN TUMORS**

The *RAD51C* mutations were significantly more frequent among the familial than unselected ovarian cancer patients, but no *RAD51D* mutations were detected among ovarian-cancer-only families. However, the sample set of ovarian-cancer-only families in this study was very small. Although not statistically significant, Song *et al.* observed that ovarian cancer patients with a mutation in any of the *RAD51B*, *RAD51C*, or *RAD51D* genes were more likely to have ovarian cancer family history (24%) than patients without mutations (14%)<sup>247</sup>. In line with our results, a higher proportion of patients with *RAD51C* mutations had a positive family history (36%,  $p = 0.021$ ), whereas only 10% of patients with *RAD51D* mutations had a family history of ovarian cancer. Consistently, *RAD51C* mutations were also associated with ovarian cancer family history in the gene-panel study of breast cancer patients by Couch *et al.*<sup>258</sup>.

As is typical for moderate-penetrance susceptibility genes<sup>39</sup>, the *RAD51C* and *RAD51D* mutations displayed incomplete segregation with the disease. Concordantly with Meindl *et al.* and Loveday *et al.*<sup>122, 139</sup>, all the tested patients with invasive breast or ovarian cancer in the *RAD51C* and *RAD51D* families were mutation carriers, but mutations were also detected in healthy women. In line with Meindl *et al.*<sup>139</sup>, we observed loss or reduction of the wild type allele in all the studied *RAD51C* and *RAD51D* ovarian tumors. In contrast, Loveday *et al.* observed LOH in one of the two available *RAD51D* ovarian tumors, while the other tumor had lost the mutant allele which is also typical for moderate-penetrance genes<sup>122</sup>.

The mutation carriers were diagnosed with ovarian cancer between 37 and 79 years of age with a slightly younger average age for *RAD51C* carriers (57.7) than for *RAD51D* carriers (59.1). For both genes, the average age at diagnosis was higher for mutation carriers than for non-carriers, but lower than the 62 years previously reported for the general population in Finland<sup>259</sup>. Slightly higher average age at ovarian cancer onset for *RAD51C* carriers was observed by Meindl *et al.* and Gevensleben *et al.*: 60 and 61.3, respectively<sup>139, 260</sup>. In line with our results, Song *et al.* and Lilyquist *et al.* reported an earlier ovarian cancer onset for *RAD51C* carriers than for *RAD51D* carriers<sup>247, 255</sup>. Song *et al.* observed that 64% of *RAD51C* and 58% of *RAD51D* mutation carriers were diagnosed with ovarian cancer at an age younger than 60 compared to 52% of non-carriers diagnosed at this age<sup>247</sup>. Four of the *RAD51C* carriers (29%) were diagnosed at the age of 40-49, whereas only one *RAD51D* carrier (8.3%) was diagnosed at this age. Lilyquist *et al.* observed a higher prevalence of *RAD51D* mutations among patients diagnosed at age 60 or older than among patients younger than that ( $p = 0.03$ ), whereas for *RAD51C* mutations there was no difference between the age groups<sup>255</sup>. In contrast, Norquist *et al.* reported a higher median age for *RAD51C* carriers (64) than for *RAD51D* carriers (54) or for patients with no mutations (62)<sup>254</sup>. However, all these studies, including ours, are based on rather small numbers of mutation carriers and there is a wide range in the age of onset.

The rarity of the mutations and the limited histopathological information makes it difficult to estimate whether *RAD51C* or *RAD51D* mutations are associated with a specific tumor phenotype. The ovarian cancers in *RAD51C* and *RAD51D* mutation carriers in this study were mainly of the most common serous subtype, in line with the initial reports by Meindl *et al.* and Loveday *et al.*<sup>122, 139</sup>. Consistent observations have been made in several follow-up studies with the majority of the ovarian tumors in *RAD51C* and *RAD51D* mutation carriers being HGSCs<sup>247, 254, 255, 260</sup>. Furthermore, Song *et al.* estimated that carriers of *RAD51B*, *RAD51C*, or *RAD51D* mutations are more likely than non-carriers to have a high-grade serous tumor versus other histologic subtypes ( $p = 0.046$ )<sup>247</sup>.

Loveday *et al.* demonstrated that *RAD51D* deficient cells are sensitive to the PARP inhibitor olaparib<sup>122</sup> and later Min *et al.* showed that *RAD51C*-deficient cancer cells are also sensitive to olaparib<sup>261</sup>. Moreover, Somyajit *et al.* discovered that *RAD51C*-deficient cells and cells with hypomorphic *RAD51C* mutations display increased activity of the error-prone repair mechanism NHEJ, and the toxicity of PARP inhibitors can be enhanced synergistically by stimulating NHEJ with a low dose of ionizing radiation in these cells<sup>262</sup>. Thus, like patients with *BRCA1* or *BRCA2* mutations, ovarian cancer patients with *RAD51C* or *RAD51D* mutations could potentially be treated with PARP inhibitors.

## 6.4 *RAD51C* AND *RAD51D* IN PROSTATE AND COLORECTAL CANCER PREDISPOSITION

Germline mutations in some breast and ovarian cancer susceptibility genes predispose to other cancer types as well, for example, *BRCA2* mutations also increase the risk of prostate and pancreatic cancers<sup>171, 175, 263</sup>. As diverse tumor types, such as uterine, prostate, pancreatic, and colorectal cancer, were present in the *RAD51C* and *RAD51D* mutation-positive families, we were prompted to study the role of the mutations in other common cancers. Various cancer types have been observed in mutation-positive families in other studies, as well<sup>121, 122, 139, 237, 239, 240, 242-244, 246, 248, 249, 264</sup>. The recurrent founder mutations identified here enabled a rapid and straightforward screening of extensive sets of prostate and colorectal cancer patients.

The absence of the *RAD51C* and *RAD51D* founder mutations among the prostate and colorectal cancer patients suggests that the mutations do not predispose to these cancer types. Thus, it is unlikely that the *RAD51C* or *RAD51D* genes contribute significantly to prostate or colorectal cancer predisposition in the Finnish population, although rare susceptibility alleles cannot be excluded. Other studies on *RAD51C* and *RAD51D* in prostate or colorectal cancer are very scarce. In a gene-panel study of 692 men with metastatic prostate cancer, Pritchard *et al.* identified one *RAD51C* and three *RAD51D* mutations<sup>176</sup>. The frequency of *RAD51C* mutations did not differ between patients and ExAC controls, whereas the frequency of *RAD51D* mutations was elevated, albeit with a nominal *p*-value of 0.02 that would not survive multiple-testing correction. Rivera *et al.* identified a pathogenic *RAD51D* missense mutation, which was a founder mutation in the French Canadian population and associated with increased risk of ovarian cancer, but was not observed among 154 colorectal cancer patients<sup>253</sup>. In gene-panel studies, Yurgelun *et al.* identified one *RAD51C* and no *RAD51D* mutations among 1 260 patients with suspected Lynch syndrome, and Pearlman *et al.* identified no *RAD51C* or *RAD51D* mutations among 450 patients with early-onset colorectal cancer<sup>265, 266</sup>. To fully establish the role of *RAD51C* and *RAD51D* mutations in prostate and colorectal cancer predisposition, further studies screening the whole coding regions of the genes in large sample-sets and in other populations are warranted.

## 6.5 GENE-PANEL TESTING IDENTIFIES MUTATIONS IN VARIOUS GENES

The gene-panel sequencing of 95 high-risk breast or ovarian cancer patients revealed clearly pathogenic mutations in 18 patients (19%) and a novel *RAD51C* duplication in a further patient (1.1%). The proportion of mutation-positive patients is somewhat higher than in the recent large gene-panel studies of breast cancer patients undergoing clinical genetic testing; Buys *et al.* reported pathogenic variants in 9.3% of 35 409 patients and Couch *et al.* in 10.2% of

41 611 patients<sup>257, 258</sup>. Smaller studies, however, have reported pathogenic mutations in approximately 12–22% of breast or ovarian cancer patients, which is more consistent with our results<sup>267-271</sup>. In our study, *BRCA1* or *BRCA2* mutations were observed in 8.4% of the patients and mutations in other genes in 10.5% of the patients. The most frequently mutated gene was *CHEK2* with 7.4% of the patients carrying at least one mutation in the gene, and the *CHEK2* mutations comprising 45% of all the identified pathogenic mutations. This is not surprising as the *CHEK2* c.1100delC has one of the highest population frequencies in Finland and has been observed in 5.5% of Finnish breast cancer families<sup>168</sup>. Several other gene-panel studies of high-risk breast or ovarian cancer patients have detected mutations in genes other than *BRCA1/2* in approximately 4–7% of patients, which is a smaller proportion than in our study<sup>245, 257, 258, 267, 269-273</sup>. Most of the difference is accounted for by the high prevalence of the *CHEK2* c.1100delC mutation in our study and in the Finnish population. While *CHEK2* was the most commonly mutated gene after *BRCA1* and *BRCA2* in the large gene-panel studies, Buys *et al.* and Couch *et al.* observed *CHEK2* mutations in only 1.1–1.7% of the patients<sup>257, 258</sup>. The genes included in the panels as well as the eligibility criteria for the patients varies between different studies, which likely also contributes to the number of mutation-positive patients reported.

The proportion of mutation-positive patients did not differ much between the patient groups ascertained on the basis of different criteria; mutations were detected in approximately 20% of the patients in most of the subgroups. The mutated genes, however, correlated with clinical and tumor characteristics. Among the ten patients ascertained based on the TNBC criteria, two *BRCA1* mutations were observed consistent with *BRCA1* tumors being often triple-negative<sup>123-125</sup>. The only mutation-positive patient affected with ovarian cancer but not breast cancer carried the *RAD51C* splicing mutation, whereas *BRCA1* and *BRCA2* mutations were observed in patients affected with both breast and ovarian cancer. This is concordant with *RAD51C* mutations increasing the risk of ovarian cancer and not breast cancer, but *BRCA1* and *BRCA2* mutations increasing the risk of both of these cancers<sup>70, 121</sup>. *CHEK2* mutations were observed in six women, all diagnosed with breast cancer before the age 40, and in a man affected with breast and thyroid cancer. All of the tumors with information on hormone receptor status were ER-positive. Consistently, previous studies have indicated an increased risk of ER-positive breast cancer, male breast cancer, and thyroid cancer for *CHEK2* mutation carriers and shown that the relative risk of breast cancer for *CHEK2* c.1100delC carriers decreases with age<sup>118, 144, 274</sup>.

The *PTEN* and *TP53* missense mutations detected in this study have been previously reported in PHTS and LFS families and the *TP53* mutation has been shown to function as a dominant negative allele<sup>275-277</sup>. In this study, however, the mutations were observed in patients who did not present the most typical features of PHTS or LFS. Interestingly, the *PTEN* mutation carrier had features of Li-Fraumeni-like syndrome with an early-onset breast cancer and a family



history of breast cancer and sarcoma although after the genetic test result, she was found to have a fibroma, goiter and trichilemmomas typical for PHTS. The *TP53* mutation carrier did not fulfill the Chompret criteria for *TP53* testing, but she was diagnosed with an early-onset HER2-positive breast cancer consistent with a previously suggested association between germline *TP53* mutations and early-onset HER2-positive breast cancer <sup>133, 278</sup>.

Two of the mutation-positive patients (8.7%) had two different protein-truncating mutations with both patients carrying the *CHEK2* mutations c.1100delC and c.444+1G>A. In addition, three patients had a *BRCA1* or *CHEK2* protein-truncating mutation and the *CHEK2* low-penetrance missense variant c.470T>C (I157T). Individuals with two pathogenic mutations may be at a higher risk than individuals with a single mutation, and low-penetrance variants may modify the risk of high and moderate-penetrance mutations. Previous studies indicate a higher risk of breast cancer for *CHEK2* compound heterozygotes and c.1100delC homozygotes than for *CHEK2* heterozygotes, but an additional *CHEK2* mutation may not further increase the risk of a *BRCA1*-positive woman <sup>279-281</sup>. The common low-risk SNPs, individually and especially in combination, have been shown to modify breast cancer risk in *BRCA1/2* and *CHEK2* mutation carriers <sup>159-161</sup>. Thus, the identification of two different mutations has value for the counselling of the patient as well as in the testing and counselling of family members, when both mutations are segregating in the family. Other breast or ovarian cancer gene-panel studies have also observed individuals with multiple susceptibility alleles, with approximately 1–4% of the mutation-positive patients carrying more than one mutation <sup>238, 254-256, 267</sup>. Gene panels have also uncovered pathogenic mutations in another susceptibility gene in patients who have previously tested negative for *BRCA1/2* mutations <sup>245, 272, 273</sup>. Lincoln *et al.* compared traditional *BRCA1/2* testing with gene-panel testing and observed deleterious mutations in other susceptibility genes in 3.9% of *BRCA1/2*-negative patients <sup>282</sup>. Moreover, additional deleterious mutations in other genes were observed in two *BRCA1/2*-positive patients as well as in two patients previously tested negative for the *BRCA1/2* mutation segregating in the family. In our study, three of the patients who had undergone previous *BRCA1/2* testing were now found to harbor either *CHEK2* or *BRCA1* mutations or the *RAD51C* duplication. Compared to *BRCA1/2* testing, panel testing of *BRCA1*, *BRCA2*, *RAD51C*, *RAD51D*, *BRIP1*, and *PALB2* mutations based on family history or clinical criteria has been shown to be more cost-effective in the UK and US populations <sup>283</sup>.

## 6.6 CNVS IDENTIFIED IN THE GENE-PANEL STUDY

Of note, two CNVs were detected among the patients tested on the gene panel: a known *BRCA1* duplication and a novel *RAD51C* duplication, which together accounted for 9.5% of all the observed pathogenic or potentially pathogenic mutations. Approximately 7% of the mutations detected in other gene-panel studies have also been CNVs and have occurred most commonly in *BRCA1* <sup>238, 254</sup>,

<sup>255, 267, 270</sup>. The high proportion of genomic changes here and in other studies underscores the importance of including a CNV detection method in cancer predisposition testing.

The *RAD51C* duplication was further observed in 0.5% of ovarian cancer patients but was absent among population controls ( $p = 0.032$ ), which suggests an increased risk of ovarian cancer for the carriers, consistent with the results of Study I on the *RAD51C* point mutations and with other published studies on *RAD51C* <sup>121, 247, 254, 255</sup>. Concordantly, the duplication frequency was not significantly elevated in breast cancer patients compared to population controls.

Previous studies have identified a recurrent *RAD51C* exon 5-9 deletion in breast or breast-ovarian cancer families <sup>284, 285</sup>. In ExAC, a duplication covering *RAD51C* exons 1-7 has been observed in 12 of 3 301 Finnish samples <sup>234</sup>. The Finnish samples on ExAC are from diverse population cohorts collected in different parts of the country. If the ExAC CNV represents the same duplication as described here, it may be possible that the duplication is more prevalent in some other parts of Finland. Due to the ancient Finnish population history, the allele frequencies differ between different geographical regions in Finland <sup>169, 170</sup>. This is evident, for example, with *BRCA1/2* founder mutations, which show geographical clustering in Finland <sup>166</sup>. However, limitations of the ExAC CNV data should be noted as it is difficult to make accurate CNV calls from targeted short read sequencing data and to accurately estimate frequencies, especially with rare events.

The duplication may be translated into a truncated protein that lacks the C-terminal amino acids needed for a proper folding of the protein, nuclear localization, and binding to the RAD51 paralogs. Thus, the duplication may disturb the formation of the RAD51C complex. Functional studies are required to further characterize the duplication at the protein level and the ovarian cancer risk association should be validated in larger datasets.

## 6.7 PREVALENCE OF *RAD51C* AND *RAD51D* MUTATIONS

While most studies on *RAD51C* and *RAD51D* have investigated out-bred populations and identified few very rare or unique mutations, the point mutations identified in Studies I and II were recurrent in the Finnish population. The shared common haplotype in the *RAD51C* and *RAD51D* mutation carrier families indicates that the identified mutations represent Finnish founder mutations. This is typical for the isolated Finnish population, where recurrent founder mutations in many disease genes, such as *BRCA1*, *BRCA2*, *PALB2*, and *CHEK2*, account for a majority of all the identified mutations in the genes <sup>166-168</sup>. The 1% *RAD51C* and 0.6% *RAD51D* mutation frequencies observed among unselected ovarian cancer patients are higher than the approximately 0.3-0.6% overall mutation frequencies observed by Song *et al.* and Norquist *et al.* <sup>247, 254</sup>. The 0.4% frequency of the *RAD51C* duplication among unselected ovarian cancer

patients was similar to the 0.5% frequencies of the c.93delG and c.837+1G>A *RAD51C* mutations individually and together they are observed at a combined 1.4% frequency among unselected ovarian cancer patients and at a 2.1% frequency among patients with personal or family history of ovarian cancer. As no other loss-of-function mutations in *RAD51D* and only a few additional singleton mutations in *RAD51C* are reported in the gnomAD database of among over 10 000 Finnish samples<sup>235</sup>, it is unlikely that other major mutations in these genes exist in the Finnish population. No other reports on *RAD51D* mutations in Finnish breast or ovarian cancer patients have been published in the literature, whereas another Finnish study on *RAD51C* was published soon after Study I. Vuorela *et al.* detected one deleterious *RAD51C* mutation (c.-13\_14del27) among 147 familial breast cancer patients from Northern Finland and another mutation (c.774delT) among 208 unselected ovarian cancer patients from Sweden<sup>237</sup>. The c.-13\_14del27 is not present in gnomAD and likely represents a unique mutation, while the Swedish c.774delT mutation is detected only among the non-Finnish Europeans. Thus, it is likely that the recurrent mutations identified in this study account for the majority of all pathogenic *RAD51C* and *RAD51D* mutations in Finns, although other very rare or unique susceptibility alleles in these genes may also exist in the Finnish population.

## 7 SUMMARY AND CONCLUSIONS

In this thesis study, recurrent founder mutations in the *RAD51C* and *RAD51D* genes were identified in Finnish breast and ovarian cancer families. Results from the extensive screening in breast, ovarian, prostate, and colorectal cancer patients suggest that the mutations increase the risk of ovarian cancer. Mutations in both genes were significantly more frequent in patients with a personal or family history of ovarian cancer than in population controls. The *RAD51C* mutation frequency was also significantly increased among familial and unselected ovarian cancer patients. The highest frequency of the *RAD51D* mutation was among breast-ovarian cancer families and it was also enriched in unselected ovarian cancer patients, although not reaching statistical significance. In contrast, mutations in neither gene were enriched in breast cancer patients, suggesting that they do not increase the risk of breast cancer, but rather that other breast cancer susceptibility alleles may be segregating in some of the mutation carrier families. The absence of the mutations among prostate and colorectal cancer patients suggests that *RAD51C* and *RAD51D* mutations do not predispose to these cancers. The *RAD51C* ex1-7 duplication identified in the gene-panel sequencing also associated with ovarian cancer risk and represented a large proportion of all the identified *RAD51C* mutations. Approximately 2% of unselected ovarian cancer patients in Finland are estimated to carry either a truncating *RAD51C* or *RAD51D* point mutation or the *RAD51C* duplication.

Altogether, the gene-panel testing identified pathogenic or potentially pathogenic mutations in approximately 20% of the high-risk breast or ovarian cancer patients, with two patients carrying two different protein-truncating mutations. Notably, more than half of the mutations were observed in genes other than *BRCA1* or *BRCA2*. Our results, together with other studies, highlight the advantage of comprehensive gene-panel testing, including a CNV detection method, as information on different types of mutations in all the relevant genes can in this way be obtained simultaneously.

The role of the *RAD51C* and *RAD51D* genes in breast and ovarian cancer predisposition have been extensively investigated by others, too. The ovarian cancer association for both genes has been confirmed and more precise risk estimates have recently been obtained. The results of other studies also indicate that *RAD51C* mutations do not increase the overall risk of breast cancer, although their role in the triple-negative subtype remains to be determined. Recent gene-panel studies, however, suggest that *RAD51D* mutations may be associated with moderately increased risk of breast cancer. In the future, it would be interesting to study both genes in specific breast cancer subtypes, such as TNBC, as well as in other cancers in large international cohorts. The prognosis and average age at disease onset of ovarian cancer patients with *RAD51C* or *RAD51D* mutations also warrant further research along with other clinical features and tumor phenotypes associated with the mutations.

The results of this thesis study have clinical value for the diagnostic testing of patients and for estimating the cancer risks associated with the *RAD51C* and *RAD51D* mutations in mutation carrier families. Recurrent founder mutations enable a rapid first-phase testing for susceptible carriers, whereas gene panels allow comprehensive and cost-effective screening of multiple genes. The *RAD51C* and *RAD51D* genes are now included in the gene panels used for clinical genetic testing of hereditary ovarian cancer as well as hereditary breast and ovarian cancer in Finland <sup>286, 287</sup> as well as in many commercially available panels <sup>3, 238, 255</sup>.

Multigene-panel testing is typically offered only for women fulfilling certain clinical criteria, such as a positive family history or early-onset disease, but it has been suggested that genetic testing should be offered for all women with invasive ovarian carcinoma <sup>288, 289</sup>. Currently, *BRCA1/2* testing is recommended for all ovarian cancer patients in some countries, although some countries restrict testing to the serous type <sup>288, 290</sup>. This strategy may prevent new ovarian cancers in the mutation carrier families as mutation-positive healthy relatives can be offered preventive measures, and it has also therapeutic implications as *BRCA1/2* mutated ovarian cancers are typically sensitive to platinum treatment and PARP inhibitors. In Finland, FINGOG recommends testing all non-mucinous epithelial ovarian tumors for somatic *BRCA1/2* mutations in order to identify patients eligible for olaparib treatment <sup>291</sup>. Mutation-positive cases are subsequently tested for germline *BRCA1/2* mutations to identify inherited predisposition, but gene-panel testing is restricted to high-risk patients. The UK National Institute for Health and Care Excellence (NICE) guidelines for Familial breast cancer recommends *BRCA1/2* testing for all patients with  $\geq 10\%$  risk of being a mutation carrier, but currently there are no standard guidelines for testing ovarian cancer patients or recommendations for gene-panel testing <sup>292</sup>. The US National Comprehensive Cancer Network (NCCN) guidelines recommend genetic testing for all ovarian cancer patients, either in the context of *BRCA1/2* testing or gene-panel testing <sup>293</sup>.

The estimated up-to-10% penetrance of *RAD51C* and *RAD51D* mutations is likely not enough to result in the clustering of ovarian cancers in families, and thus family-history-based screening would miss most mutation carriers. Likewise, screening all ovarian cancer patients for *RAD51C* and *RAD51D* mutations may not substantially reduce ovarian cancer incidence, but it might have therapeutic implications as *RAD51C* and *RAD51D* deficient cells are also sensitive to PARP inhibitors. To prevent future ovarian cancers in the mutation carriers, testing of *RAD51C* or *RAD51D* mutations in all women in the population would perhaps be the most effective <sup>290</sup>. In fact, population-based panel testing of *BRCA1*, *BRCA2*, *RAD51C*, *RAD51D*, *BRIP1*, and *PALB2* mutations is estimated to be more cost-effective than clinical criteria-based panel and *BRCA1/2* testing <sup>283</sup>, but the acceptability and uptake of such testing has not been evaluated. Thus, if population-based *RAD51C* and *RAD51D* testing is considered, it should be performed in the context of gene-panel testing and the psychological effects of the testing should be carefully evaluated first. Identified carriers of breast-cancer susceptibility alleles may benefit from more careful surveillance, and can opt for

preventive measures such as prophylactic bilateral mastectomy. As there are no effective pre-symptomatic screening methods for ovarian cancer, it is important to identify high-risk women, and preventive measures such as risk-reducing salpingo-oophorectomy can be offered to women carrying germline susceptibility alleles. Although risk-reducing salpingo-oophorectomy is traditionally offered to high-risk women, it may be beneficial also for women with an intermediate >4-5% lifetime risk of ovarian cancer and could thus be offered to *RAD51C* and *RAD51D* mutation carriers<sup>97</sup>.

## ACKNOWLEDGEMENTS

This thesis study was carried out at the Department of Obstetrics and Gynecology, Helsinki University Hospital. I would like to thank the current and former heads of the Department of Obstetrics and Gynecology, professors Juha Tapanainen and Jorma Paavonen for providing excellent research facilities.

I want to express my sincere gratitude to my supervisor, docent Heli Nevanlinna for giving me an opportunity to work on this interesting field of research. I am grateful for the opportunities to take part in various research projects, to take responsibility, and to grow as a scientist.

I am deeply grateful to the official reviewers, docents Sirpa Kivirikko and Csilla Sipeky for their advice and valuable comments that significantly improved this thesis, and to the thesis committee members, professors Aila Tiitinen and Arto Mannermaa for their encouragement and support.

I want to warmly thank all my collaborators and co-authors without whom this work would not have been possible: our senior clinicians Kristiina Aittomäki, Carl Blomqvist, and Päivi Heikkilä, and collaborators Ralf Bützow, Anne Kallioniemi, Johanna Schleutker, and Lauri Aaltonen for sharing their clinical expertise and for providing patient samples and data, as well as co-authors Deborah Thompson, Kaija Holli, Riikka Nurminen, Alexandra Gylfe, Arto Leminen, Fergus Couch, Hermela Shimelis, Heidi Toiminien, Åke Borg, Anders Kvist, and Therese Törngren for successful collaboration. Special thanks go to research nurses Outi Malkavaara, Irja Erkkilä, Virpi Palola, and Hanna Jäntti for their invaluable help with the patient samples and data. I want to thank the FIMM Sequencing Unit for their excellent services.

My sincere thanks go to all the current and former members of our research group. I want to thank Taru Muranen, Johanna Kiiski, Anna Nurmi, Maija Suvanto, Erja Nynäs, Himanshu Chheda, Sini Lehto, Salla Ranta, Sofia Khan, Tuomas Heikkinen, Maral Jamshidi, and Rainer Fagerholm for their help and assistance and for sharing the ups and downs in the office and lab; in particular, Johanna and Taru for peer support and Maija for mentoring and answering my endless questions during the writing process of this thesis, as well as Tuomas, Maral, Johanna, and Sofia for their great company at the conference trips.

I want to warmly thank my colleagues at the neighboring labs from the Departments of Obstetrics and Gynecology and of Clinical Chemistry for creating a pleasant working environment. Special thanks go to Krisse for her invaluable help, guidance, and expertise in the lab.

My warmest thanks go to my wonderful friends Aija, Laura, Lissu, Satu, and Kaisu for their support and friendship. Above all I want to thank my family for their love and support: my parents Marja and Tapani, my siblings Maija and Hannu, and my little niece Erika. My heartfelt thanks go to my dear husband Ben for all his love, encouragement, and support, and for always believing in me.

*Acknowledgements*

I am grateful for the financial support of the Emil Aaltonen Foundation, the Paulo Foundation, the Finnish Cultural Foundation, the Biomedicum Helsinki Foundation, the Oskar Öflund Foundation, the Maud Kuistila Memorial Foundation, the Alfred Kordelin Foundation, the University of Helsinki Fund for Medicine, the Orion Research Foundation, and the Cancer Foundation of Finland as well as the Sigrid Juselius Foundation, the Helsinki University Central Hospital Research Fund, and the Academy of Finland.

Finally, I want to express my gratitude to all the patients and families who volunteered to participate in the study.

Helsinki, June 2018

*Liisa Pelttari*



## REFERENCES

1. Torre LA, Bray F, Siegel RL, Ferlay J, Lortet-Tieulent J, Jemal A: Global cancer statistics, 2012. *CA Cancer J Clin* 2015, **65**:87-108.
2. Nielsen FC, van Overeem Hansen T, Sorensen CS: Hereditary breast and ovarian cancer: new genes in confined pathways. *Nat Rev Cancer* 2016, **16**:599-612.
3. Easton DF, Pharoah PD, Antoniou AC, Tischkowitz M, Tavtigian SV, Nathanson KL, Devilee P, Meindl A, Couch FJ, Southey M, Goldgar DE, Evans DG, Chenevix-Trench G, Rahman N, Robson M, Domchek SM, Foulkes WD: Gene-panel sequencing and the prediction of breast-cancer risk. *N Engl J Med* 2015, **372**:2243-2257.
4. Finnish Cancer Registry, <https://tilastot.syoparekisteri.fi/syovat>, data 29.9.2017 [Accessed May 9, 2018]
5. Hanahan D, Weinberg RA: The hallmarks of cancer. *Cell* 2000, **100**:57-70.
6. Hanahan D, Weinberg RA: Hallmarks of cancer: the next generation. *Cell* 2011, **144**:646-674.
7. Kreso A, Dick JE: Evolution of the cancer stem cell model. *Cell Stem Cell* 2014, **14**:275-291.
8. Nowell PC: The clonal evolution of tumor cell populations. *Science* 1976, **194**:23-28.
9. Stratton MR, Campbell PJ, Futreal PA: The cancer genome. *Nature* 2009, **458**:719-724.
10. Vogelstein B, Kinzler KW: The Path to Cancer --Three Strikes and You're Out. *N Engl J Med* 2015, **373**:1895-1898.
11. Greenman C, Stephens P, Smith R, Dalgliesh GL, Hunter C, Bignell G, Davies H, Teague J, Butler A, Stevens C, Edkins S, O'Meara S, Vastrik I, Schmidt EE, Avis T, Barthorpe S, Bhamra G, Buck G, Choudhury B, Clements J, Cole J, Dicks E, Forbes S, Gray K, Halliday K, Harrison R, Hills K, Hinton J, Jenkinson A, Jones D, Menzies A, Mironenko T, Perry J, Raine K, Richardson D, Shepherd R, Small A, Tofts C, Varian J, Webb T, West S, Widaa S, Yates A, Cahill DP, Louis DN, Goldstraw P, Nicholson AG, Brasseur F, Looijenga L, Weber BL, *et al*: Patterns of somatic mutation in human cancer genomes. *Nature* 2007, **446**:153-158.
12. Jackson SP, Bartek J: The DNA-damage response in human biology and disease. *Nature* 2009, **461**:1071-1078.
13. Lord CJ, Ashworth A: The DNA damage response and cancer therapy. *Nature* 2012, **481**:287-294.
14. Suwaki N, Klare K, Tarsounas M: RAD51 paralogs: roles in DNA damage signalling, recombinational repair and tumorigenesis. *Semin Cell Dev Biol* 2011, **22**:898-905.
15. Ceccaldi R, Sarangi P, D'Andrea AD: The Fanconi anaemia pathway: new players and new functions. *Nat Rev Mol Cell Biol* 2016, **17**:337-349.

16. Lawrence MS, Stojanov P, Mermel CH, Robinson JT, Garraway LA, Golub TR, Meyerson M, Gabriel SB, Lander ES, Getz G: Discovery and saturation analysis of cancer genes across 21 tumour types. *Nature* 2014, **505**:495-501.
17. Vogelstein B, Kinzler KW: Cancer genes and the pathways they control. *Nat Med* 2004, **10**:789-799.
18. Kinzler KW, Vogelstein B: Cancer-susceptibility genes. Gatekeepers and caretakers. *Nature* 1997, **386**:761, 763.
19. Croce CM: Oncogenes and cancer. *N Engl J Med* 2008, **358**:502-511.
20. Davies H, Bignell GR, Cox C, Stephens P, Edkins S, Clegg S, Teague J, Woffendin H, Garnett MJ, Bottomley W, Davis N, Dicks E, Ewing R, Floyd Y, Gray K, Hall S, Hawes R, Hughes J, Kosmidou V, Menzies A, Mould C, Parker A, Stevens C, Watt S, Hooper S, Wilson R, Jayatilake H, Gusterson BA, Cooper C, Shipley J, Hargrave D, Pritchard-Jones K, Maitland N, Chenevix-Trench G, Riggins GJ, Bigner DD, Palmieri G, Cossu A, Flanagan A, Nicholson A, Ho JW, Leung SY, Yuen ST, Weber BL, Seigler HF, Darrow TL, Paterson H, Marais R, Marshall CJ, Wooster R, *et al*: Mutations of the BRAF gene in human cancer. *Nature* 2002, **417**:949-954.
21. Friend SH, Bernards R, Rogelj S, Weinberg RA, Rapaport JM, Albert DM, Dryja TP: A human DNA segment with properties of the gene that predisposes to retinoblastoma and osteosarcoma. *Nature* 1986, **323**:643-646.
22. Knudson AG: Two genetic hits (more or less) to cancer. *Nat Rev Cancer* 2001, **1**:157-162.
23. Kinzler KW, Vogelstein B: Landscaping the cancer terrain. *Science* 1998, **280**:1036-1037.
24. Croce CM: Causes and consequences of microRNA dysregulation in cancer. *Nat Rev Genet* 2009, **10**:704-714.
25. Iorio MV, Croce CM: MicroRNA dysregulation in cancer: diagnostics, monitoring and therapeutics. A comprehensive review. *EMBO Mol Med* 2012, **4**:143-159.
26. Huarte M: The emerging role of lncRNAs in cancer. *Nat Med* 2015, **21**:1253-1261.
27. Calin GA, Dumitru CD, Shimizu M, Bichi R, Zupo S, Noch E, Aldler H, Rattan S, Keating M, Rai K, Rassenti L, Kipps T, Negrini M, Bullrich F, Croce CM: Frequent deletions and down-regulation of micro- RNA genes miR15 and miR16 at 13q14 in chronic lymphocytic leukemia. *Proc Natl Acad Sci U S A* 2002, **99**:15524-15529.
28. Cimmino A, Calin GA, Fabbri M, Iorio MV, Ferracin M, Shimizu M, Wojcik SE, Aqeilan RI, Zupo S, Dono M, Rassenti L, Alder H, Volinia S, Liu CG, Kipps TJ, Negrini M, Croce CM: miR-15 and miR-16 induce apoptosis by targeting BCL2. *Proc Natl Acad Sci U S A* 2005, **102**:13944-13949.
29. Rahman N: Realizing the promise of cancer predisposition genes. *Nature* 2014, **505**:302-308.
30. Miki Y, Swensen J, Shattuck-Eidens D, Futreal PA, Harshman K, Tavtigian S, Liu Q, Cochran C, Bennett LM, Ding W: A strong candidate for the breast and ovarian cancer susceptibility gene BRCA1. *Science* 1994, **266**:66-71.

31. Wooster R, Bignell G, Lancaster J, Swift S, Seal S, Mangion J, Collins N, Gregory S, Gumbs C, Micklem G: Identification of the breast cancer susceptibility gene BRCA2. *Nature* 1995, **378**:789-792.
32. Donis-Keller H, Dou S, Chi D, Carlson KM, Toshima K, Lairmore TC, Howe JR, Moley JF, Goodfellow P, Wells SA, Jr: Mutations in the RET proto-oncogene are associated with MEN 2A and FMTC. *Hum Mol Genet* 1993, **2**:851-856.
33. Mulligan LM, Kwok JB, Healey CS, Elsdon MJ, Eng C, Gardner E, Love DR, Mole SE, Moore JK, Papi L: Germ-line mutations of the RET proto-oncogene in multiple endocrine neoplasia type 2A. *Nature* 1993, **363**:458-460.
34. Schmidt L, Duh FM, Chen F, Kishida T, Glenn G, Choyke P, Scherer SW, Zhuang Z, Lubensky I, Dean M, Allikmets R, Chidambaram A, Bergerheim UR, Feltis JT, Casadevall C, Zamarron A, Bernues M, Richard S, Lips CJ, Walther MM, Tsui LC, Geil L, Orcutt ML, Stackhouse T, Lipan J, Slife L, Brauch H, Decker J, Niehans G, Hughson MD, Moch H, Storkel S, Lerman MI, Linehan WM, Zbar B: Germline and somatic mutations in the tyrosine kinase domain of the MET proto-oncogene in papillary renal carcinomas. *Nat Genet* 1997, **16**:68-73.
35. Fishel R, Lescoe MK, Rao MR, Copeland NG, Jenkins NA, Garber J, Kane M, Kolodner R: The human mutator gene homolog MSH2 and its association with hereditary nonpolyposis colon cancer. *Cell* 1993, **75**:1027-1038.
36. Leach FS, Nicolaides NC, Papadopoulos N, Liu B, Jen J, Parsons R, Peltomaki P, Sistonen P, Aaltonen LA, Nystrom-Lahti M: Mutations of a mutS homolog in hereditary nonpolyposis colorectal cancer. *Cell* 1993, **75**:1215-1225.
37. Nicolaides NC, Papadopoulos N, Liu B, Wei YF, Carter KC, Ruben SM, Rosen CA, Haseltine WA, Fleischmann RD, Fraser CM: Mutations of two PMS homologues in hereditary nonpolyposis colon cancer. *Nature* 1994, **371**:75-80.
38. Lynch HT, de la Chapelle A: Hereditary colorectal cancer. *N Engl J Med* 2003, **348**:919-932.
39. Fletcher O, Houlston RS: Architecture of inherited susceptibility to common cancer. *Nat Rev Cancer* 2010, **10**:353-361.
40. Knudson AG, Jr: Mutation and cancer: statistical study of retinoblastoma. *Proc Natl Acad Sci U S A* 1971, **68**:820-823.
41. Allemani C, Weir HK, Carreira H, Harewood R, Spika D, Wang XS, Bannon F, Ahn JV, Johnson CJ, Bonaventure A, Marcos-Gragera R, Stiller C, Azevedo e Silva G, Chen WQ, Ogunbiyi OJ, Rachet B, Soeberg MJ, You H, Matsuda T, Bielska-Lasota M, Storm H, Tucker TC, Coleman MP, CONCORD Working Group: Global surveillance of cancer survival 1995-2009: analysis of individual data for 25,676,887 patients from 279 population-based registries in 67 countries (CONCORD-2). *Lancet* 2015, **385**:977-1010.
42. Althuis MD, Dozier JM, Anderson WF, Devesa SS, Brinton LA: Global trends in breast cancer incidence and mortality 1973-1997. *Int J Epidemiol* 2005, **34**:405-412.

43. Berry DA, Cronin KA, Plevritis SK, Fryback DG, Clarke L, Zelen M, Mandelblatt JS, Yakovlev AY, Habbema JD, Feuer EJ, Cancer Intervention and Surveillance Modeling Network (CISNET) Collaborators: Effect of screening and adjuvant therapy on mortality from breast cancer. *N Engl J Med* 2005, **353**:1784-1792.
44. Diseases of the Breast. Harris, Lippman, Morrow and Osborne. Wolters Kluwer Health, Philadelphia 2014.
45. WHO Classification of Tumours of the Breast. Lakhani, Ellis and Schnitt. International Agency for Research on Cancer, Lyon 2012.
46. Dieci MV, Orvieto E, Dominici M, Conte P, Guarneri V: Rare breast cancer subtypes: histological, molecular, and clinical peculiarities. *Oncologist* 2014, **19**:805-813.
47. Rakha EA, Reis-Filho JS, Baehner F, Dabbs DJ, Decker T, Eusebi V, Fox SB, Ichihara S, Jacquemier J, Lakhani SR, Palacios J, Richardson AL, Schnitt SJ, Schmitt FC, Tan PH, Tse GM, Badve S, Ellis IO: Breast cancer prognostic classification in the molecular era: the role of histological grade. *Breast Cancer Res* 2010, **12**:207.
48. Cuzick J, Dowsett M, Pineda S, Wale C, Salter J, Quinn E, Zabaglo L, Mallon E, Green AR, Ellis IO, Howell A, Buzdar AU, Forbes JF: Prognostic value of a combined estrogen receptor, progesterone receptor, Ki-67, and human epidermal growth factor receptor 2 immunohistochemical score and comparison with the Genomic Health recurrence score in early breast cancer. *J Clin Oncol* 2011, **29**:4273-4278.
49. Elston CW, Ellis IO: Pathological prognostic factors in breast cancer. I. The value of histological grade in breast cancer: experience from a large study with long-term follow-up. *Histopathology* 1991, **19**:403-410.
50. Sobin LH: TNM: principles, history, and relation to other prognostic factors. *Cancer* 2001, **91**:1589-1592.
51. Perou CM, Sorlie T, Eisen MB, van de Rijn M, Jeffrey SS, Rees CA, Pollack JR, Ross DT, Johnsen H, Akslen LA, Fluge O, Pergamenschikov A, Williams C, Zhu SX, Lonning PE, Borresen-Dale AL, Brown PO, Botstein D: Molecular portraits of human breast tumours. *Nature* 2000, **406**:747-752.
52. Sorlie T, Perou CM, Tibshirani R, Aas T, Geisler S, Johnsen H, Hastie T, Eisen MB, van de Rijn M, Jeffrey SS, Thorsen T, Quist H, Matese JC, Brown PO, Botstein D, Eystein Lonning P, Borresen-Dale AL: Gene expression patterns of breast carcinomas distinguish tumor subclasses with clinical implications. *Proc Natl Acad Sci U S A* 2001, **98**:10869-10874.
53. Parker JS, Mullins M, Cheang MC, Leung S, Voduc D, Vickery T, Davies S, Fauron C, He X, Hu Z, Quackenbush JF, Stijleman IJ, Palazzo J, Marron JS, Nobel AB, Mardis E, Nielsen TO, Ellis MJ, Perou CM, Bernard PS: Supervised risk predictor of breast cancer based on intrinsic subtypes. *J Clin Oncol* 2009, **27**:1160-1167.
54. Cancer Genome Atlas Network: Comprehensive molecular portraits of human breast tumours. *Nature* 2012, **490**:61-70.

55. Russnes HG, Lingjaerde OC, Borresen-Dale AL, Caldas C: Breast Cancer Molecular Stratification: From Intrinsic Subtypes to Integrative Clusters. *Am J Pathol* 2017, **187**:2152-2162.
56. Curtis C, Shah SP, Chin SF, Turashvili G, Rueda OM, Dunning MJ, Speed D, Lynch AG, Samarajiwa S, Yuan Y, Graf S, Ha G, Haffari G, Bashashati A, Russell R, McKinney S, METABRIC Group, Langerod A, Green A, Provenzano E, Wishart G, Pinder S, Watson P, Markowitz F, Murphy L, Ellis I, Purushotham A, Borresen-Dale AL, Brenton JD, Tavare S, Caldas C, Aparicio S: The genomic and transcriptomic architecture of 2,000 breast tumours reveals novel subgroups. *Nature* 2012, **486**:346-352.
57. Key TJ, Verkasalo PK, Banks E: Epidemiology of breast cancer. *Lancet Oncol* 2001, **2**:133-140.
58. Collaborative Group on Hormonal Factors in Breast Cancer: Breast cancer and breastfeeding: collaborative reanalysis of individual data from 47 epidemiological studies in 30 countries, including 50302 women with breast cancer and 96973 women without the disease. *Lancet* 2002, **360**:187-195.
59. Marjoribanks J, Farquhar C, Roberts H, Lethaby A, Lee J: Long-term hormone therapy for perimenopausal and postmenopausal women. *Cochrane Database Syst Rev* 2017, **1**:CD004143.
60. Bassuk SS, Manson JE: Oral contraceptives and menopausal hormone therapy: relative and attributable risks of cardiovascular disease, cancer, and other health outcomes. *Ann Epidemiol* 2015, **25**:193-200.
61. Lahmann PH, Hoffmann K, Allen N, van Gils CH, Khaw KT, Tehard B, Berrino F, Tjonneland A, Bigaard J, Olsen A, Overvad K, Clavel-Chapelon F, Nagel G, Boeing H, Trichopoulos D, Economou G, Bellos G, Palli D, Tumino R, Panico S, Sacerdote C, Krogh V, Peeters PH, Bueno-de-Mesquita HB, Lund E, Ardanaz E, Amiano P, Pera G, Quiros JR, Martinez C, Tormo MJ, Wirfalt E, Berglund G, Hallmans G, Key TJ, Reeves G, Bingham S, Norat T, Biessy C, Kaaks R, Riboli E: Body size and breast cancer risk: findings from the European Prospective Investigation into Cancer And Nutrition (EPIC). *Int J Cancer* 2004, **111**:762-771.
62. Scoccianti C, Lauby-Secretan B, Bello PY, Chajes V, Romieu I: Female breast cancer and alcohol consumption: a review of the literature. *Am J Prev Med* 2014, **46**:S16-25.
63. Wu Y, Zhang D, Kang S: Physical activity and risk of breast cancer: a meta-analysis of prospective studies. *Breast Cancer Res Treat* 2013, **137**:869-882.
64. Ordonez-Mena JM, Schottker B, Mons U, Jenab M, Freisling H, Bueno-de-Mesquita B, O'Doherty MG, Scott A, Kee F, Stricker BH, Hofman A, de Keyser CE, Ruiter R, Soderberg S, Jousilahti P, Kuulasmaa K, Freedman ND, Wilsgaard T, de Groot LC, Kampman E, Hakansson N, Orsini N, Wolk A, Nilsson LM, Tjonneland A, Pajak A, Malyutina S, Kubinova R, Tamosiunas A, Bobak M, Katsoulis M, Orfanos P, Boffetta P, Trichopoulou A, Brenner H, Consortium on Health and Ageing: Network of Cohorts in Europe and the United States (CHANCES): Quantification of the smoking-associated cancer risk with rate

advancement periods: meta-analysis of individual participant data from cohorts of the CHANCES consortium. *BMC Med* 2016, **14**:62-016-0607-5.

65. Carter BD, Abnet CC, Feskanich D, Freedman ND, Hartge P, Lewis CE, Ockene JK, Prentice RL, Speizer FE, Thun MJ, Jacobs EJ: Smoking and mortality--beyond established causes. *N Engl J Med* 2015, **372**:631-640.

66. Collaborative Group on Hormonal Factors in Breast Cancer: Familial breast cancer: collaborative reanalysis of individual data from 52 epidemiological studies including 58,209 women with breast cancer and 101,986 women without the disease. *Lancet* 2001, **358**:1389-1399.

67. Brewer HR, Jones ME, Schoemaker MJ, Ashworth A, Swerdlow AJ: Family history and risk of breast cancer: an analysis accounting for family structure. *Breast Cancer Res Treat* 2017, **165**:193-200.

68. Mucci LA, Hjelmborg JB, Harris JR, Czene K, Havelick DJ, Scheike T, Graff RE, Holst K, Moller S, Unger RH, McIntosh C, Nuttall E, Brandt I, Penney KL, Hartman M, Kraft P, Parmigiani G, Christensen K, Koskenvuo M, Holm NV, Heikkila K, Pukkala E, Skytthe A, Adami HO, Kaprio J, Nordic Twin Study of Cancer (NorTwinCan) Collaboration: Familial Risk and Heritability of Cancer Among Twins in Nordic Countries. *JAMA* 2016, **315**:68-76.

69. Ghossaini M, Pharoah PD, Easton DF: Inherited genetic susceptibility to breast cancer: the beginning of the end or the end of the beginning? *Am J Pathol* 2013, **183**:1038-1051.

70. Kuchenbaecker KB, Hopper JL, Barnes DR, Phillips KA, Mooij TM, Roos-Blom MJ, Jervis S, van Leeuwen FE, Milne RL, Andrieu N, Goldgar DE, Terry MB, Rookus MA, Easton DF, Antoniou AC, BRCA1 and BRCA2 Cohort C, McGuffog L, Evans DG, Barrowdale D, Frost D, Adlard J, Ong KR, Izatt L, Tischkowitz M, Eeles R, Davidson R, Hodgson S, Ellis S, Nogues C, Lasset C, Stoppa-Lyonnet D, Fricker JP, Faivre L, Berthet P, Hooning MJ, van der Kolk LE, Kets CM, Adank MA, John EM, Chung WK, Andrulis IL, Southey M, Daly MB, Buys SS, Osorio A, Engel C, Kast K, Schmutzler RK, Caldes T, Jakubowska A, *et al*: Risks of Breast, Ovarian, and Contralateral Breast Cancer for BRCA1 and BRCA2 Mutation Carriers. *JAMA* 2017, **317**:2402-2416.

71. Sopik V, Iqbal J, Rosen B, Narod SA: Why have ovarian cancer mortality rates declined? Part I. Incidence. *Gynecol Oncol* 2015, **138**:741-749.

72. Prat J, FIGO Committee on Gynecologic Oncology: Staging classification for cancer of the ovary, fallopian tube, and peritoneum. *Int J Gynaecol Obstet* 2014, **124**:1-5.

73. Shih I, Kurman RJ: Ovarian tumorigenesis: a proposed model based on morphological and molecular genetic analysis. *Am J Pathol* 2004, **164**:1511-1518.

74. Kurman RJ, Shih I: The Dualistic Model of Ovarian Carcinogenesis: Revisited, Revised, and Expanded. *Am J Pathol* 2016, **186**:733-747.

75. Meinhold-Heerlein I, Fotopoulou C, Harter P, Kurzeder C, Mustea A, Wimberger P, Hauptmann S, Sehouli J: The new WHO classification of ovarian, fallopian tube, and

- primary peritoneal cancer and its clinical implications. *Arch Gynecol Obstet* 2016, **293**:695-700.
76. Yemelyanova A, Vang R, Kshirsagar M, Lu D, Marks MA, Shih I, Kurman RJ: Immunohistochemical staining patterns of p53 can serve as a surrogate marker for TP53 mutations in ovarian carcinoma: an immunohistochemical and nucleotide sequencing analysis. *Mod Pathol* 2011, **24**:1248-1253.
77. Cancer Genome Atlas Research Network: Integrated genomic analyses of ovarian carcinoma. *Nature* 2011, **474**:609-615.
78. Kindelberger DW, Lee Y, Miron A, Hirsch MS, Feltmate C, Medeiros F, Callahan MJ, Garner EO, Gordon RW, Birch C, Berkowitz RS, Muto MG, Crum CP: Intraepithelial carcinoma of the fimbria and pelvic serous carcinoma: Evidence for a causal relationship. *Am J Surg Pathol* 2007, **31**:161-169.
79. Callahan MJ, Crum CP, Medeiros F, Kindelberger DW, Elvin JA, Garber JE, Feltmate CM, Berkowitz RS, Muto MG: Primary fallopian tube malignancies in BRCA-positive women undergoing surgery for ovarian cancer risk reduction. *J Clin Oncol* 2007, **25**:3985-3990.
80. Karnezis AN, Cho KR, Gilks CB, Pearce CL, Huntsman DG: The disparate origins of ovarian cancers: pathogenesis and prevention strategies. *Nat Rev Cancer* 2017, **17**:65-74.
81. Schuler S, Ponnath M, Engel J, Ortmann O: Ovarian epithelial tumors and reproductive factors: a systematic review. *Arch Gynecol Obstet* 2013, **287**:1187-1204.
82. Collaborative Group on Epidemiological Studies of Ovarian Cancer, Beral V, Doll R, Hermon C, Peto R, Reeves G: Ovarian cancer and oral contraceptives: collaborative reanalysis of data from 45 epidemiological studies including 23,257 women with ovarian cancer and 87,303 controls. *Lancet* 2008, **371**:303-314.
83. Collaborative Group On Epidemiological Studies Of Ovarian Cancer, Beral V, Gaitskell K, Hermon C, Moser K, Reeves G, Peto R: Menopausal hormone use and ovarian cancer risk: individual participant meta-analysis of 52 epidemiological studies. *Lancet* 2015, **385**:1835-1842.
84. Gong TT, Wu QJ, Vogtmann E, Lin B, Wang YL: Age at menarche and risk of ovarian cancer: a meta-analysis of epidemiological studies. *Int J Cancer* 2013, **132**:2894-2900.
85. Tsilidis KK, Allen NE, Key TJ, Dossus L, Lukanova A, Bakken K, Lund E, Fournier A, Overvad K, Hansen L, Tjonneland A, Fedirko V, Rinaldi S, Romieu I, Clavel-Chapelon F, Engel P, Kaaks R, Schutze M, Steffen A, Bamia C, Trichopoulou A, Zylis D, Masala G, Pala V, Galasso R, Tumino R, Sacerdote C, Bueno-de-Mesquita HB, van Duijnhoven FJ, Braem MG, Onland-Moret NC, Gram IT, Rodriguez L, Travier N, Sanchez MJ, Huerta JM, Ardanaz E, Larranaga N, Jirstrom K, Manjer J, Idahl A, Ohlson N, Khaw KT, Wareham N, Mouw T, Norat T, Riboli E: Oral contraceptive use and reproductive factors and risk of ovarian cancer in the European Prospective Investigation into Cancer and Nutrition. *Br J Cancer* 2011, **105**:1436-1442.

86. Collaborative Group on Epidemiological Studies of Ovarian Cancer: Ovarian cancer and body size: individual participant meta-analysis including 25,157 women with ovarian cancer from 47 epidemiological studies. *PLoS Med* 2012, **9**:e1001200.
87. Olsen CM, Nagle CM, Whiteman DC, Ness R, Pearce CL, Pike MC, Rossing MA, Terry KL, Wu AH, Australian Cancer Study (Ovarian Cancer), Australian Ovarian Cancer Study Group, Risch HA, Yu H, Doherty JA, Chang-Claude J, Hein R, Nickels S, Wang-Gohrke S, Goodman MT, Carney ME, Matsuno RK, Lurie G, Moysich K, Kjaer SK, Jensen A, Hogdall E, Goode EL, Fridley BL, Vierkant RA, Larson MC, Schildkraut J, Hoyo C, Moorman P, Weber RP, Cramer DW, Vitonis AF, Bandera EV, Olson SH, Rodriguez-Rodriguez L, King M, Brinton LA, Yang H, Garcia-Closas M, Lissowska J, Anton-Culver H, Ziogas A, Gayther SA, Ramus SJ, Menon U, Gentry-Maharaj A, *et al*: Obesity and risk of ovarian cancer subtypes: evidence from the Ovarian Cancer Association Consortium. *Endocr Relat Cancer* 2013, **20**:251-262.
88. Aune D, Navarro Rosenblatt DA, Chan DS, Abar L, Vingeliene S, Vieira AR, Greenwood DC, Norat T: Anthropometric factors and ovarian cancer risk: a systematic review and nonlinear dose-response meta-analysis of prospective studies. *Int J Cancer* 2015, **136**:1888-1898.
89. Collaborative Group on Epidemiological Studies of Ovarian Cancer, Beral V, Gaitskell K, Hermon C, Moser K, Reeves G, Peto R: Ovarian cancer and smoking: individual participant meta-analysis including 28,114 women with ovarian cancer from 51 epidemiological studies. *Lancet Oncol* 2012, **13**:946-956.
90. Faber MT, Kjaer SK, Dehlendorff C, Chang-Claude J, Andersen KK, Hogdall E, Webb PM, Jordan SJ, Australian Cancer Study (Ovarian Cancer), Australian Ovarian Cancer Study Group, Rossing MA, Doherty JA, Lurie G, Thompson PJ, Carney ME, Goodman MT, Ness RB, Modugno F, Edwards RP, Bunker CH, Goode EL, Fridley BL, Vierkant RA, Larson MC, Schildkraut J, Cramer DW, Terry KL, Vitonis AF, Bandera EV, Olson SH, King M, Chandran U, Kiemeny LA, Massuger LF, van Altena AM, Vermeulen SH, Brinton L, Wentzensen N, Lissowska J, Yang HP, Moysich KB, Odunsi K, Kasza K, Odunsi-Akanji O, Song H, Pharaoh P, Shah M, Whittemore AS, McGuire V, Sieh W, *et al*: Cigarette smoking and risk of ovarian cancer: a pooled analysis of 21 case-control studies. *Cancer Causes Control* 2013, **24**:989-1004.
91. Wentzensen N, Poole EM, Trabert B, White E, Arslan AA, Patel AV, Setiawan VW, Visvanathan K, Weiderpass E, Adami HO, Black A, Bernstein L, Brinton LA, Buring J, Butler LM, Chamosa S, Clendenen TV, Dossus L, Fortner R, Gapstur SM, Gaudet MM, Gram IT, Hartge P, Hoffman-Bolton J, Idahl A, Jones M, Kaaks R, Kirsh V, Koh WP, Lacey JV, Jr, Lee IM, Lundin E, Merritt MA, Onland-Moret NC, Peters U, Poynter JN, Rinaldi S, Robien K, Rohan T, Sandler DP, Schairer C, Schouten LJ, Sjöholm LK, Sieri S, Swerdlow A, Tjønneland A, Travis R, Trichopoulou A, van den Brandt PA, Wilkens L, *et al*: Ovarian Cancer Risk Factors by Histologic Subtype: An Analysis From the Ovarian Cancer Cohort Consortium. *J Clin Oncol* 2016, **34**:2888-2898.
92. Pearce CL, Templeman C, Rossing MA, Lee A, Near AM, Webb PM, Nagle CM, Doherty JA, Cushing-Haugen KL, Wicklund KG, Chang-Claude J, Hein R, Lurie G, Wilkens LR, Carney ME, Goodman MT, Moysich K, Kjaer SK, Hogdall E, Jensen A, Goode EL, Fridley



BL, Larson MC, Schildkraut JM, Palmieri RT, Cramer DW, Terry KL, Vitonis AF, Titus LJ, Ziogas A, Brewster W, Anton-Culver H, Gentry-Maharaj A, Ramus SJ, Anderson AR, Brueggmann D, Fasching PA, Gayther SA, Huntsman DG, Menon U, Ness RB, Pike MC, Risch H, Wu AH, Berchuck A, Ovarian Cancer Association Consortium: Association between endometriosis and risk of histological subtypes of ovarian cancer: a pooled analysis of case-control studies. *Lancet Oncol* 2012, **13**:385-394.

93. Stratton JF, Pharoah P, Smith SK, Easton D, Ponder BA: A systematic review and meta-analysis of family history and risk of ovarian cancer. *Br J Obstet Gynaecol* 1998, **105**:493-499.

94. Jervis S, Song H, Lee A, Dicks E, Tyrer J, Harrington P, Easton DF, Jacobs IJ, Pharoah PP, Antoniou AC: Ovarian cancer familial relative risks by tumour subtypes and by known ovarian cancer genetic susceptibility variants. *J Med Genet* 2014, **51**:108-113.

95. Buys SS, Partridge E, Black A, Johnson CC, Lamerato L, Isaacs C, Reding DJ, Greenlee RT, Yokochi LA, Kessel B, Crawford ED, Church TR, Andriole GL, Weissfeld JL, Fouad MN, Chia D, O'Brien B, Ragard LR, Clapp JD, Rathmell JM, Riley TL, Hartge P, Pinsky PF, Zhu CS, Izmirlian G, Kramer BS, Miller AB, Xu JL, Prorok PC, Gohagan JK, Berg CD, PLCO Project Team: Effect of screening on ovarian cancer mortality: the Prostate, Lung, Colorectal and Ovarian (PLCO) Cancer Screening Randomized Controlled Trial. *JAMA* 2011, **305**:2295-2303.

96. Jacobs IJ, Menon U, Ryan A, Gentry-Maharaj A, Burnell M, Kalsi JK, Amso NN, Apostolidou S, Benjamin E, Cruickshank D, Crump DN, Davies SK, Dawnay A, Dobbs S, Fletcher G, Ford J, Godfrey K, Gunu R, Habib M, Hallett R, Herod J, Jenkins H, Karpinskyj C, Leeson S, Lewis SJ, Liston WR, Lopes A, Mould T, Murdoch J, Oram D, Rabideau DJ, Reynolds K, Scott I, Seif MW, Sharma A, Singh N, Taylor J, Warburton F, Widschwendter M, Williamson K, Woolas R, Fallowfield L, McGuire AJ, Campbell S, Parmar M, Skates SJ: Ovarian cancer screening and mortality in the UK Collaborative Trial of Ovarian Cancer Screening (UKCTOCS): a randomised controlled trial. *Lancet* 2016, **387**:945-956.

97. Manchanda R, Menon U: Setting the Threshold for Surgical Prevention in Women at Increased Risk of Ovarian Cancer. *Int J Gynecol Cancer* 2018, **28**:34-42.

98. Mavaddat N, Pharoah PD, Michailidou K, Tyrer J, Brook MN, Bolla MK, Wang Q, Dennis J, Dunning AM, Shah M, Luben R, Brown J, Bojesen SE, Nordestgaard BG, Nielsen SF, Flyger H, Czene K, Darabi H, Eriksson M, Peto J, Dos-Santos-Silva I, Dudbridge F, Johnson N, Schmidt MK, Brooks A, Verhoef S, Rutgers EJ, Swerdlow A, Ashworth A, Orr N, Schoemaker MJ, Figueroa J, Chanock SJ, Brinton L, Lissowska J, Couch FJ, Olson JE, Vachon C, Pankratz VS, Lambrechts D, Wildiers H, Van Ongeval C, van Limbergen E, Kristensen V, Grenaker Alnaes G, Nord S, Borresen-Dale AL, Nevanlinna H, Muranen TA, Aittomaki K, *et al*: Prediction of breast cancer risk based on profiling with common genetic variants. *J Natl Cancer Inst* 2015, **107**:10.1093/jnci/djv036.

99. Phelan CM, Kuchenbaecker KB, Tyrer JP, Kar SP, Lawrenson K, Winham SJ, Dennis J, Pirie A, Riggan MJ, Chornokur G, Earp MA, Lyra PC, Jr, Lee JM, Coetzee S, Beesley J, McGuffog L, Soucy P, Dicks E, Lee A, Barrowdale D, Lecarpentier J, Leslie G, Aalfs CM, Aben KKH, Adams M, Adlard J, Andrulis IL, Anton-Culver H, Antonenkova N, AOCS study

group, Aravantinos G, Arnold N, Arun BK, Arver B, Azzollini J, Balmana J, Banerjee SN, Barjhoux L, Barkardottir RB, Bean Y, Beckmann MW, Beeghly-Fadiel A, Benitez J, Bermisheva M, Bernardini MQ, Birrer MJ, Bjorge L, Black A, Blankstein K, Blok MJ, *et al*: Identification of 12 new susceptibility loci for different histotypes of epithelial ovarian cancer. *Nat Genet* 2017, **49**:680-691.

100. Michailidou K, Lindstrom S, Dennis J, Beesley J, Hui S, Kar S, Lemacon A, Soucy P, Glubb D, Rostamianfar A, Bolla MK, Wang Q, Tyrer J, Dicks E, Lee A, Wang Z, Allen J, Keeman R, Eilber U, French JD, Qing Chen X, Fachal L, McCue K, McCart Reed AE, Ghossaini M, Carroll JS, Jiang X, Finucane H, Adams M, Adank MA, Ahsan H, Aittomaki K, Anton-Culver H, Antonenkova NN, Arndt V, Aronson KJ, Arun B, Auer PL, Bacot F, Barrdahl M, Baynes C, Beckmann MW, Behrens S, Benitez J, Bermisheva M, Bernstein L, Blomqvist C, Bogdanova NV, Bojesen SE, Bonanni B, *et al*: Association analysis identifies 65 new breast cancer risk loci. *Nature* 2017, **551**:92-94.

101. Antoniou A, Pharoah PD, Narod S, Risch HA, Eyfjord JE, Hopper JL, Loman N, Olsson H, Johannsson O, Borg A, Pasini B, Radice P, Manoukian S, Eccles DM, Tang N, Olah E, Anton-Culver H, Warner E, Lubinski J, Gronwald J, Gorski B, Tulinius H, Thorlacius S, Eerola H, Nevanlinna H, Syrjakoski K, Kallioniemi OP, Thompson D, Evans C, Peto J, Lalloo F, Evans DG, Easton DF: Average risks of breast and ovarian cancer associated with BRCA1 or BRCA2 mutations detected in case Series unselected for family history: a combined analysis of 22 studies. *Am J Hum Genet* 2003, **72**:1117-1130.

102. Chen S, Parmigiani G: Meta-analysis of BRCA1 and BRCA2 penetrance. *J Clin Oncol* 2007, **25**:1329-1333.

103. Kast K, Rhiem K, Wappenschmidt B, Hahnen E, Hauke J, Bluemcke B, Zarghooni V, Herold N, Ditsch N, Kiechle M, Braun M, Fischer C, Dikow N, Schott S, Rahner N, Niederacher D, Fehm T, Gehrig A, Mueller-Reible C, Arnold N, Maass N, Borck G, de Gregorio N, Scholz C, Auber B, Varon-Manteeva R, Speiser D, Horvath J, Lichey N, Wimberger P, Stark S, Faust U, Weber BH, Emons G, Zachariae S, Meindl A, Schmutzler RK, Engel C, German Consortium for Hereditary Breast and Ovarian Cancer (GC-HBOC): Prevalence of BRCA1/2 germline mutations in 21 401 families with breast and ovarian cancer. *J Med Genet* 2016, **53**:465-471.

104. Vehmanen P, Friedman LS, Eerola H, McClure M, Ward B, Sarantaus L, Kainu T, Syrjakoski K, Pyrhonen S, Kallioniemi OP, Muhonen T, Luce M, Frank TS, Nevanlinna H: Low proportion of BRCA1 and BRCA2 mutations in Finnish breast cancer families: evidence for additional susceptibility genes. *Hum Mol Genet* 1997, **6**:2309-2315.

105. Sarantaus L, Auranen A, Nevanlinna H: BRCA1 and BRCA2 mutations among Finnish ovarian carcinoma families. *Int J Oncol* 2001, **18**:831-835.

106. Syrjakoski K, Vahteristo P, Eerola H, Tamminen A, Kivinummi K, Sarantaus L, Holli K, Blomqvist C, Kallioniemi OP, Kainu T, Nevanlinna H: Population-based study of BRCA1 and BRCA2 mutations in 1035 unselected Finnish breast cancer patients. *J Natl Cancer Inst* 2000, **92**:1529-1531.

107. Sarantaus L, Vahteristo P, Bloom E, Tamminen A, Unkila-Kallio L, Butzow R, Nevanlinna H: BRCA1 and BRCA2 mutations among 233 unselected Finnish ovarian carcinoma patients. *Eur J Hum Genet* 2001, **9**:424-430.
108. Tai YC, Domchek S, Parmigiani G, Chen S: Breast cancer risk among male BRCA1 and BRCA2 mutation carriers. *J Natl Cancer Inst* 2007, **99**:1811-1814.
109. Mai PL, Best AF, Peters JA, DeCastro RM, Khincha PP, Loud JT, Bremer RC, Rosenberg PS, Savage SA: Risks of first and subsequent cancers among TP53 mutation carriers in the National Cancer Institute Li-Fraumeni syndrome cohort. *Cancer* 2016, **122**:3673-3681.
110. Ngeow J, Sesock K, Eng C: Breast cancer risk and clinical implications for germline PTEN mutation carriers. *Breast Cancer Res Treat* 2017, **165**:1-8.
111. Beggs AD, Latchford AR, Vasen HF, Moslein G, Alonso A, Aretz S, Bertario L, Blanco I, Bulow S, Burn J, Capella G, Colas C, Friedl W, Moller P, Hes FJ, Jarvinen H, Mecklin JP, Nagengast FM, Parc Y, Phillips RK, Hyer W, Ponz de Leon M, Renkonen-Sinisalo L, Sampson JR, Stormorken A, Tejpar S, Thomas HJ, Wijnen JT, Clark SK, Hodgson SV: Peutz-Jeghers syndrome: a systematic review and recommendations for management. *Gut* 2010, **59**:975-986.
112. Hansford S, Kaurah P, Li-Chang H, Woo M, Senz J, Pinheiro H, Schrader KA, Schaeffer DF, Shumansky K, Zogopoulos G, Santos TA, Claro I, Carvalho J, Nielsen C, Padilla S, Lum A, Talhouk A, Baker-Lange K, Richardson S, Lewis I, Lindor NM, Pennell E, MacMillan A, Fernandez B, Keller G, Lynch H, Shah SP, Guilford P, Gallinger S, Corso G, Roviello F, Caldas C, Oliveira C, Pharoah PD, Huntsman DG: Hereditary Diffuse Gastric Cancer Syndrome: CDH1 Mutations and Beyond. *JAMA Oncol* 2015, **1**:23-32.
113. Seminog OO, Goldacre MJ: Age-specific risk of breast cancer in women with neurofibromatosis type 1. *Br J Cancer* 2015, **112**:1546-1548.
114. Uusitalo E, Rantanen M, Kallionpaa RA, Poyhonen M, Leppavirta J, Yla-Outinen H, Riccardi VM, Pukkala E, Pitkaniemi J, Peltonen S, Peltonen J: Distinctive Cancer Associations in Patients With Neurofibromatosis Type 1. *J Clin Oncol* 2016, **34**:1978-1986.
115. Barrow E, Hill J, Evans DG: Cancer risk in Lynch Syndrome. *Fam Cancer* 2013, **12**:229-240.
116. van Os NJ, Roeleveld N, Weemaes CM, Jongmans MC, Janssens GO, Taylor AM, Hoogerbrugge N, Willemsen MA: Health risks for ataxia-telangiectasia mutated heterozygotes: a systematic review, meta-analysis and evidence-based guideline. *Clin Genet* 2016, **90**:105-117.
117. Weischer M, Bojesen SE, Ellervik C, Tybjaerg-Hansen A, Nordestgaard BG: CHEK2\*1100delC genotyping for clinical assessment of breast cancer risk: meta-analyses of 26,000 patient cases and 27,000 controls. *J Clin Oncol* 2008, **26**:542-548.
118. Schmidt MK, Hogervorst F, van Hien R, Cornelissen S, Broeks A, Adank MA, Meijers H, Waisfisz Q, Hollestelle A, Schutte M, van den Ouweland A, Hooning M, Andrulis IL, Anton-Culver H, Antonenkova NN, Antoniou AC, Arndt V, Bermisheva M, Bogdanova NV, Bolla MK, Brauch H, Brenner H, Bruning T, Burwinkel B, Chang-Claude J, Chenevix-Trench G, Couch FJ, Cox A, Cross SS, Czene K, Dunning AM, Fasching PA, Figueroa J,

Fletcher O, Flyger H, Galle E, Garcia-Closas M, Giles GG, Haeberle L, Hall P, Hillemanns P, Hopper JL, Jakubowska A, John EM, Jones M, Khusnutdinova E, Knight JA, Kosma VM, Kristensen V, Lee A, *et al*: Age- and Tumor Subtype-Specific Breast Cancer Risk Estimates for CHEK2\*1100delC Carriers. *J Clin Oncol* 2016, **34**:2750-2760.

119. Antoniou AC, Casadei S, Heikkinen T, Barrowdale D, Pylkas K, Roberts J, Lee A, Subramanian D, De Leeneer K, Fostira F, Tomiak E, Neuhausen SL, Teo ZL, Khan S, Aittomaki K, Moilanen JS, Turnbull C, Seal S, Mannermaa A, Kallioniemi A, Lindeman GJ, Buys SS, Andrulis IL, Radice P, Tondini C, Manoukian S, Toland AE, Miron P, Weitzel JN, Domchek SM, Poppe B, Claes KB, Yannoukakos D, Concannon P, Bernstein JL, James PA, Easton DF, Goldgar DE, Hopper JL, Rahman N, Peterlongo P, Nevanlinna H, King MC, Couch FJ, Southey MC, Winqvist R, Foulkes WD, Tischkowitz M: Breast-cancer risk in families with mutations in PALB2. *N Engl J Med* 2014, **371**:497-506.

120. Ramus SJ, Song H, Dicks E, Tyrer JP, Rosenthal AN, Intermaggio MP, Fraser L, Gentry-Maharaj A, Hayward J, Philpott S, Anderson C, Edlund CK, Conti D, Harrington P, Barrowdale D, Bowtell DD, Alsop K, Mitchell G, AOC Study Group, Cicek MS, Cunningham JM, Fridley BL, Alsop J, Jimenez-Linan M, Poblete S, Lele S, Sucheston-Campbell L, Moysich KB, Sieh W, McGuire V, Lester J, Bogdanova N, Durst M, Hillemanns P, Ovarian Cancer Association Consortium, Odunsi K, Whittemore AS, Karlan BY, Dork T, Goode EL, Menon U, Jacobs IJ, Antoniou AC, Pharoah PD, Gayther SA: Germline Mutations in the BRIP1, BARD1, PALB2, and NBN Genes in Women With Ovarian Cancer. *J Natl Cancer Inst* 2015, **107**:10.1093/jnci/djv214.

121. Loveday C, Turnbull C, Ruark E, Xicola RM, Ramsay E, Hughes D, Warren-Perry M, Snape K, Breast Cancer Susceptibility Collaboration (BCSC) (UK), Eccles D, Evans DG, Gore M, Renwick A, Seal S, Antoniou AC, Rahman N: Germline RAD51C mutations confer susceptibility to ovarian cancer. *Nat Genet* 2012, **44**:475-476.

122. Loveday C, Turnbull C, Ramsay E, Hughes D, Ruark E, Frankum JR, Bowden G, Kalmyrzaev B, Warren-Perry M, Snape K, Adlard JW, Barwell J, Berg J, Brady AF, Brewer C, Brice G, Chapman C, Cook J, Davidson R, Donaldson A, Douglas F, Greenhalgh L, Henderson A, Izatt L, Kumar A, Laloo F, Miedzybrodzka Z, Morrison PJ, Paterson J, Porteous M, Rogers MT, Shanley S, Walker L, Breast Cancer Susceptibility Collaboration (UK), Eccles D, Evans DG, Renwick A, Seal S, Lord CJ, Ashworth A, Reis-Filho JS, Antoniou AC, Rahman N: Germline mutations in RAD51D confer susceptibility to ovarian cancer. *Nat Genet* 2011, **43**:879-882.

123. Mavaddat N, Barrowdale D, Andrulis IL, Domchek SM, Eccles D, Nevanlinna H, Ramus SJ, Spurdle A, Robson M, Sherman M, Mulligan AM, Couch FJ, Engel C, McGuffog L, Healey S, Sinilnikova OM, Southey MC, Terry MB, Goldgar D, O'Malley F, John EM, Janavicius R, Tihomirova L, Hansen TV, Nielsen FC, Osorio A, Stavropoulou A, Benitez J, Manoukian S, Peissel B, Barile M, Volorio S, Pasini B, Dolcetti R, Putignano AL, Ottini L, Radice P, Hamann U, Rashid MU, Hogervorst FB, Kriege M, van der Luijt RB, HEBON, Peock S, Frost D, Evans DG, Brewer C, Walker L, Rogers MT, Side LE, *et al*: Pathology of breast and ovarian cancers among BRCA1 and BRCA2 mutation carriers: results from the Consortium of Investigators of Modifiers of BRCA1/2 (CIMBA). *Cancer Epidemiol Biomarkers Prev* 2012, **21**:134-147.

124. Spurdle AB, Couch FJ, Parsons MT, McGuffog L, Barrowdale D, Bolla MK, Wang Q, Healey S, Schmutzler R, Wappenschmidt B, Rhiem K, Hahnen E, Engel C, Meindl A, Ditsch N, Arnold N, Plendl H, Niederacher D, Sutter C, Wang-Gohrke S, Steinemann D, Preisler-Adams S, Kast K, Varon-Mateeva R, Ellis S, Frost D, Platte R, Perkins J, Evans DG, Izatt L, Eeles R, Adlard J, Davidson R, Cole T, Scuvera G, Manoukian S, Bonanni B, Mariette F, Fortuzzi S, Viel A, Pasini B, Papi L, Varesco L, Balleine R, Nathanson KL, Domchek SM, Offitt K, Jakubowska A, Lindor N, Thomassen M, *et al*: Refined histopathological predictors of BRCA1 and BRCA2 mutation status: a large-scale analysis of breast cancer characteristics from the BCAC, CIMBA, and ENIGMA consortia. *Breast Cancer Res* 2014, **16**:3419-014-0474-y.
125. Stevens KN, Vachon CM, Couch FJ: Genetic susceptibility to triple-negative breast cancer. *Cancer Res* 2013, **73**:2025-2030.
126. van den Broek AJ, Schmidt MK, van 't Veer LJ, Tollenaar RA, van Leeuwen FE: Worse breast cancer prognosis of BRCA1/BRCA2 mutation carriers: what's the evidence? A systematic review with meta-analysis. *PLoS One* 2015, **10**:e0120189.
127. Candido-dos-Reis FJ, Song H, Goode EL, Cunningham JM, Fridley BL, Larson MC, Alsop K, Dicks E, Harrington P, Ramus SJ, de Fazio A, Mitchell G, Fereday S, Bolton KL, Gourley C, Michie C, Karlan B, Lester J, Walsh C, Cass I, Olsson H, Gore M, Benitez JJ, Garcia MJ, Andrulis I, Mulligan AM, Glendon G, Blanco I, Lazaro C, Whittemore AS, McGuire V, Sieh W, Montagna M, Alducci E, Sadetzki S, Chetrit A, Kwong A, Kjaer SK, Jensen A, Hogdall E, Neuhausen S, Nussbaum R, Daly M, Greene MH, Mai PL, Loud JT, Moysich K, Toland AE, Lambrechts D, Ellis S, *et al*: Germline mutation in BRCA1 or BRCA2 and ten-year survival for women diagnosed with epithelial ovarian cancer. *Clin Cancer Res* 2015, **21**:652-657.
128. Lord CJ, Ashworth A: BRCAness revisited. *Nat Rev Cancer* 2016, **16**:110-120.
129. Farmer H, McCabe N, Lord CJ, Tutt AN, Johnson DA, Richardson TB, Santarosa M, Dillon KJ, Hickson I, Knights C, Martin NM, Jackson SP, Smith GC, Ashworth A: Targeting the DNA repair defect in BRCA mutant cells as a therapeutic strategy. *Nature* 2005, **434**:917-921.
130. Bryant HE, Schultz N, Thomas HD, Parker KM, Flower D, Lopez E, Kyle S, Meuth M, Curtin NJ, Helleday T: Specific killing of BRCA2-deficient tumours with inhibitors of poly(ADP-ribose) polymerase. *Nature* 2005, **434**:913-917.
131. Walsh MF, Chang VY, Kohlmann WK, Scott HS, Cunniff C, Bourdeaut F, Molenaar JJ, Porter CC, Sandlund JT, Plon SE, Wang LL, Savage SA: Recommendations for Childhood Cancer Screening and Surveillance in DNA Repair Disorders. *Clin Cancer Res* 2017, **23**:e23-e31.
132. Malkin D, Li FP, Strong LC, Fraumeni JF, Jr, Nelson CE, Kim DH, Kassel J, Gryka MA, Bischoff FZ, Tainsky MA: Germ line p53 mutations in a familial syndrome of breast cancer, sarcomas, and other neoplasms. *Science* 1990, **250**:1233-1238.

133. McBride KA, Ballinger ML, Killick E, Kirk J, Tattersall MH, Eeles RA, Thomas DM, Mitchell G: Li-Fraumeni syndrome: cancer risk assessment and clinical management. *Nat Rev Clin Oncol* 2014, **11**:260-271.
134. Liaw D, Marsh DJ, Li J, Dahia PL, Wang SI, Zheng Z, Bose S, Call KM, Tsou HC, Peacocke M, Eng C, Parsons R: Germline mutations of the PTEN gene in Cowden disease, an inherited breast and thyroid cancer syndrome. *Nat Genet* 1997, **16**:64-67.
135. Hemminki A, Markie D, Tomlinson I, Avizienyte E, Roth S, Loukola A, Bignell G, Warren W, Aminoff M, Hoglund P, Jarvinen H, Kristo P, Pelin K, Ridanpaa M, Salovaara R, Toro T, Bodmer W, Olschwang S, Olsen AS, Stratton MR, de la Chapelle A, Aaltonen LA: A serine/threonine kinase gene defective in Peutz-Jeghers syndrome. *Nature* 1998, **391**:184-187.
136. Guilford PJ, Hopkins JB, Grady WM, Markowitz SD, Willis J, Lynch H, Rajput A, Wiesner GL, Lindor NM, Burgart LJ, Toro TT, Lee D, Limacher JM, Shaw DW, Findlay MP, Reeve AE: E-cadherin germline mutations define an inherited cancer syndrome dominated by diffuse gastric cancer. *Hum Mutat* 1999, **14**:249-255.
137. Seminog OO, Goldacre MJ: Risk of benign tumours of nervous system, and of malignant neoplasms, in people with neurofibromatosis: population-based record-linkage study. *Br J Cancer* 2013, **108**:193-198.
138. Helder-Woolderink JM, Blok EA, Vasen HF, Hollema H, Mourits MJ, De Bock GH: Ovarian cancer in Lynch syndrome; a systematic review. *Eur J Cancer* 2016, **55**:65-73.
139. Meindl A, Hellebrand H, Wiek C, Erven V, Wappenschmidt B, Niederacher D, Freund M, Lichtner P, Hartmann L, Schaal H, Ramser J, Honisch E, Kubisch C, Wichmann HE, Kast K, Deissler H, Engel C, Muller-Myhsok B, Neveling K, Kiechle M, Mathew CG, Schindler D, Schmutzler RK, Hanenberg H: Germline mutations in breast and ovarian cancer pedigrees establish RAD51C as a human cancer susceptibility gene. *Nat Genet* 2010, **42**:410-414.
140. Rafnar T, Gudbjartsson DF, Sulem P, Jonasdottir A, Sigurdsson A, Jonasdottir A, Besenbacher S, Lundin P, Stacey SN, Gudmundsson J, Magnusson OT, le Roux L, Orlygsdottir G, Helgadóttir HT, Johannsdóttir H, Gylfason A, Tryggvadóttir L, Jonasson JG, de Juan A, Ortega E, Ramon-Cajal JM, Garcia-Prats MD, Mayordomo C, Panadero A, Rivera F, Aben KK, van Altena AM, Massuger LF, Aavikko M, Kujala PM, Staff S, Aaltonen LA, Olafsdóttir K, Bjornsson J, Kong A, Salvarsdóttir A, Saemundsson H, Olafsson K, Benediktsdóttir KR, Gulcher J, Masson G, Kiemeny LA, Mayordomo JI, Thorsteinsdóttir U, Stefansson K: Mutations in BRIP1 confer high risk of ovarian cancer. *Nat Genet* 2011, **43**:1104-1107.
141. Rahman N, Seal S, Thompson D, Kelly P, Renwick A, Elliott A, Reid S, Spanova K, Barfoot R, Chagtai T, Jayatilake H, McGuffog L, Hanks S, Evans DG, Eccles D, Breast Cancer Susceptibility Collaboration (UK), Easton DF, Stratton MR: PALB2, which encodes a BRCA2-interacting protein, is a breast cancer susceptibility gene. *Nat Genet* 2007, **39**:165-167.

142. Meijers-Heijboer H, van den Ouweland A, Klijn J, Wasielewski M, de Snoo A, Oldenburg R, Hollestelle A, Houben M, Crepin E, van Veghel-Plandsoen M, Elstrodt F, van Duijn C, Bartels C, Meijers C, Schutte M, McGuffog L, Thompson D, Easton D, Sodha N, Seal S, Barfoot R, Mangion J, Chang-Claude J, Eccles D, Eeles R, Evans DG, Houlston R, Murday V, Narod S, Peretz T, Peto J, Phelan C, Zhang HX, Szabo C, Devilee P, Goldgar D, Futreal PA, Nathanson KL, Weber B, Rahman N, Stratton MR, CHEK2-Breast Cancer Consortium: Low-penetrance susceptibility to breast cancer due to CHEK2(\*)1100delC in noncarriers of BRCA1 or BRCA2 mutations. *Nat Genet* 2002, **31**:55-59.
143. Renwick A, Thompson D, Seal S, Kelly P, Chagtai T, Ahmed M, North B, Jayatilake H, Barfoot R, Spanova K, McGuffog L, Evans DG, Eccles D, Breast Cancer Susceptibility Collaboration (UK), Easton DF, Stratton MR, Rahman N: ATM mutations that cause ataxia-telangiectasia are breast cancer susceptibility alleles. *Nat Genet* 2006, **38**:873-875.
144. Pritzlaff M, Summerour P, McFarland R, Li S, Reineke P, Dolinsky JS, Goldgar DE, Shimelis H, Couch FJ, Chao EC, LaDuca H: Male breast cancer in a multi-gene panel testing cohort: insights and unexpected results. *Breast Cancer Res Treat* 2017, **161**:575-586.
145. Easton DF, Lesueur F, Decker B, Michailidou K, Li J, Allen J, Luccarini C, Pooley KA, Shah M, Bolla MK, Wang Q, Dennis J, Ahmad J, Thompson ER, Damiola F, Pertesi M, Voegelé C, Mebirouk N, Robinot N, Durand G, Forey N, Luben RN, Ahmed S, Aittomaki K, Anton-Culver H, Arndt V, Australian Ovarian Cancer Study Group, Baynes C, Beckman MW, Benitez J, Van Den Berg D, Blot WJ, Bogdanova NV, Bojesen SE, Brenner H, Chang-Claude J, Chia KS, Choi JY, Conroy DM, Cox A, Cross SS, Czene K, Darabi H, Devilee P, Eriksson M, Fasching PA, Figueroa J, Flyger H, Fostira F, Garcia-Closas M, *et al*: No evidence that protein truncating variants in BRIP1 are associated with breast cancer risk: implications for gene panel testing. *J Med Genet* 2016, **53**:298-309.
146. Vaz F, Hanenberg H, Schuster B, Barker K, Wiek C, Erven V, Neveling K, Endt D, Kesterton I, Autore F, Fraternali F, Freund M, Hartmann L, Grimwade D, Roberts RG, Schaal H, Mohammed S, Rahman N, Schindler D, Mathew CG: Mutation of the RAD51C gene in a Fanconi anemia-like disorder. *Nat Genet* 2010, **42**:406-409.
147. Pang Z, Yao L, Zhang J, Ouyang T, Li J, Wang T, Fan Z, Fan T, Lin B, Xie Y: RAD51C germline mutations in Chinese women with familial breast cancer. *Breast Cancer Res Treat* 2011, **129**:1019-1020.
148. Wong MW, Nordfors C, Mossman D, Pecenetelovska G, Avery-Kiejda KA, Talseth-Palmer B, Bowden NA, Scott RJ: BRIP1, PALB2, and RAD51C mutation analysis reveals their relative importance as genetic susceptibility factors for breast cancer. *Breast Cancer Res Treat* 2011, **127**:853-859.
149. Akbari MR, Tonin P, Foulkes WD, Ghadirian P, Tischkowitz M, Narod SA: RAD51C germline mutations in breast and ovarian cancer patients. *Breast Cancer Res* 2010, **12**:404.
150. Zheng Y, Zhang J, Hope K, Niu Q, Huo D, Olopade OI: Screening RAD51C nucleotide alterations in patients with a family history of breast and ovarian cancer. *Breast Cancer Res Treat* 2010, **124**:857-861.

151. Zhang G, Zeng Y, Liu Z, Wei W: Significant association between Nijmegen breakage syndrome 1 657del5 polymorphism and breast cancer risk. *Tumour Biol* 2013, **34**:2753-2757.
152. Kiiski JI, Pelttari LM, Khan S, Freysteinsdottir ES, Reynisdottir I, Hart SN, Shimelis H, Vilske S, Kallioniemi A, Schleutker J, Leminen A, Butzow R, Blomqvist C, Barkardottir RB, Couch FJ, Aittomaki K, Nevanlinna H: Exome sequencing identifies FANCM as a susceptibility gene for triple-negative breast cancer. *Proc Natl Acad Sci U S A* 2014, **111**:15172-15177.
153. Bogliolo M, Bluteau D, Lespinasse J, Pujol R, Vasquez N, d'Enghien CD, Stoppa-Lyonnet D, Leblanc T, Soulier J, Surrallès J: Biallelic truncating FANCM mutations cause early-onset cancer but not Fanconi anemia. *Genet Med* 2018, **20**:458-463.
154. Neidhardt G, Hauke J, Ramser J, Gross E, Gehrig A, Müller CR, Kahlert AK, Hackmann K, Honisch E, Niederacher D, Heilmann-Heimbach S, Franke A, Lieb W, Thiele H, Altmüller J, Nurnberg P, Klaschik K, Ernst C, Ditsch N, Jessen F, Ramirez A, Wappenschmidt B, Engel C, Rhiem K, Meindl A, Schmutzler RK, Hahnen E: Association Between Loss-of-Function Mutations Within the FANCM Gene and Early-Onset Familial Breast Cancer. *JAMA Oncol* 2017, **3**:1245-1248.
155. Kar SP, Beesley J, Amin Al Olama A, Michailidou K, Tyrer J, Kote-Jarai Z, Lawrenson K, Lindstrom S, Ramus SJ, Thompson DJ, ABCTB Investigators, Kibel AS, Dansonka-Mieszkowska A, Michael A, Dieffenbach AK, Gentry-Maharaj A, Whittemore AS, Wolk A, Monteiro A, Peixoto A, Kierzek A, Cox A, Rudolph A, Gonzalez-Neira A, Wu AH, Lindblom A, Swerdlow A, AOCs Study Group & Australian Cancer Study (Ovarian Cancer), APCB BioResource, Ziogas A, Ekici AB, Burwinkel B, Karlan BY, Nordestgaard BG, Blomqvist C, Phelan C, McLean C, Pearce CL, Vachon C, Cybulski C, Slavov C, Stegmaier C, Maier C, Ambrosone CB, Hogdall CK, Teerlink CC, Kang D, Tessier DC, Schaid DJ, Stram DO, *et al*: Genome-Wide Meta-Analyses of Breast, Ovarian, and Prostate Cancer Association Studies Identify Multiple New Susceptibility Loci Shared by at Least Two Cancer Types. *Cancer Discov* 2016, **6**:1052-1067.
156. Milne RL, Kuchenbaecker KB, Michailidou K, Beesley J, Kar S, Lindstrom S, Hui S, Lemacon A, Soucy P, Dennis J, Jiang X, Rostamianfar A, Finucane H, Bolla MK, McGuffog L, Wang Q, Aalfs CM, ABCTB Investigators, Adams M, Adlard J, Agata S, Ahmed S, Ahsan H, Aittomaki K, Al-Ejeh F, Allen J, Ambrosone CB, Amos CI, Andrulis IL, Anton-Culver H, Antonenkova NN, Arndt V, Arnold N, Aronson KJ, Auber B, Auer PL, Ausems MGEM, Azzollini J, Bacot F, Balmana J, Barile M, Barjhoux L, Barkardottir RB, Barrdahl M, Barnes D, Barrowdale D, Baynes C, Beckmann MW, Benitez J, Bermisheva M, *et al*: Identification of ten variants associated with risk of estrogen-receptor-negative breast cancer. *Nat Genet* 2017, **49**:1767-1778.
157. Shen H, Fridley BL, Song H, Lawrenson K, Cunningham JM, Ramus SJ, Cicek MS, Tyrer J, Stram D, Larson MC, Kobel M, PRACTICAL Consortium, Ziogas A, Zheng W, Yang HP, Wu AH, Wozniak EL, Woo YL, Winterhoff B, Wik E, Whittemore AS, Wentzensen N, Weber RP, Vitonis AF, Vincent D, Vierkant RA, Vergote I, Van Den Berg D, Van Altena AM, Tworoger SS, Thompson PJ, Tessier DC, Terry KL, Teo SH, Templeman C, Stram DO, Southey MC, Sieh W, Siddiqui N, Shvetsov YB, Shu XO, Shridhar V, Wang-Gohrke S, Severi



G, Schwaab I, Salvesen HB, Rzepecka IK, Runnebaum IB, Rossing MA, Rodriguez-Rodriguez L, *et al*: Epigenetic analysis leads to identification of HNF1B as a subtype-specific susceptibility gene for ovarian cancer. *Nat Commun* 2013, **4**:1628.

158. Kelemen LE, Lawrenson K, Tyrer J, Li Q, Lee JM, Seo JH, Phelan CM, Beesley J, Chen X, Spindler TJ, Aben KK, Anton-Culver H, Antonenkova N, Australian Cancer Study, Australian Ovarian Cancer Study Group, Ovarian Cancer Association Consortium: Genome-wide significant risk associations for mucinous ovarian carcinoma. *Nat Genet* 2015, **47**:888-897.

159. Kuchenbaecker KB, Neuhausen SL, Robson M, Barrowdale D, McGuffog L, Mulligan AM, Andrulis IL, Spurdle AB, Schmidt MK, Schmutzler RK, Engel C, Wappenschmidt B, Nevanlinna H, Thomassen M, Southey M, Radice P, Ramus SJ, Domchek SM, Nathanson KL, Lee A, Healey S, Nussbaum RL, Rebbeck TR, Arun BK, James P, Karlan BY, Lester J, Cass I, Breast Cancer Family Registry, Terry MB, Daly MB, Goldgar DE, Buys SS, Janavicius R, Tihomirova L, Tung N, Dorfling CM, van Rensburg EJ, Steele L, v O Hansen T, Ejlertsen B, Gerdes AM, Nielsen FC, Dennis J, Cunningham J, Hart S, Slager S, Osorio A, Benitez J, Duran M, *et al*: Associations of common breast cancer susceptibility alleles with risk of breast cancer subtypes in BRCA1 and BRCA2 mutation carriers. *Breast Cancer Res* 2014, **16**:3416-014-0492-9.

160. Kuchenbaecker KB, McGuffog L, Barrowdale D, Lee A, Soucy P, Dennis J, Domchek SM, Robson M, Spurdle AB, Ramus SJ, Mavaddat N, Terry MB, Neuhausen SL, Schmutzler RK, Simard J, Pharoah PDP, Offit K, Couch FJ, Chenevix-Trench G, Easton DF, Antoniou AC: Evaluation of Polygenic Risk Scores for Breast and Ovarian Cancer Risk Prediction in BRCA1 and BRCA2 Mutation Carriers. *J Natl Cancer Inst* 2017, **109**:10.1093/jnci/djw302.

161. Muranen TA, Greco D, Blomqvist C, Aittomaki K, Khan S, Hogervorst F, Verhoef S, Pharoah PDP, Dunning AM, Shah M, Luben R, Bojesen SE, Nordestgaard BG, Schoemaker M, Swerdlow A, Garcia-Closas M, Figueroa J, Dork T, Bogdanova NV, Hall P, Li J, Khusnutdinova E, Bermisheva M, Kristensen V, Borresen-Dale AL, Investigators N, Peto J, Dos Santos Silva I, Couch FJ, Olson JE, Hillemans P, Park-Simon TW, Brauch H, Hamann U, Burwinkel B, Marme F, Meindl A, Schmutzler RK, Cox A, Cross SS, Sawyer EJ, Tomlinson I, Lambrechts D, Moisse M, Lindblom A, Margolin S, Hollestelle A, Martens JWM, Fasching PA, Beckmann MW, *et al*: Genetic modifiers of CHEK2\*1100delC-associated breast cancer risk. *Genet Med* 2017, **19**:599-603.

162. Jervis S, Song H, Lee A, Dicks E, Harrington P, Baynes C, Manchanda R, Easton DF, Jacobs I, Pharoah PP, Antoniou AC: A risk prediction algorithm for ovarian cancer incorporating BRCA1, BRCA2, common alleles and other familial effects. *J Med Genet* 2015, **52**:465-475.

163. Kaariainen H, Muilu J, Perola M, Kristiansson K: Genetics in an isolated population like Finland: a different basis for genomic medicine? *J Community Genet* 2017, **8**:319-326.

164. Chheda H, Palta P, Pirinen M, McCarthy S, Walter K, Koskinen S, Salomaa V, Daly M, Durbin R, Palotie A, Aittokallio T, Ripatti S: Whole-genome view of the consequences of a population bottleneck using 2926 genome sequences from Finland and United Kingdom. *Eur J Hum Genet* 2017, **25**:477-484.

165. Lim ET, Wurtz P, Havulinna AS, Palta P, Tukiainen T, Rehnstrom K, Esko T, Magi R, Inouye M, Lappalainen T, Chan Y, Salem RM, Lek M, Flannick J, Sim X, Manning A, Ladenvall C, Bumpstead S, Hamalainen E, Aalto K, Maksimow M, Salmi M, Blankenberg S, Ardissino D, Shah S, Horne B, McPherson R, Hovingh GK, Reilly MP, Watkins H, Goel A, Farrall M, Girelli D, Reiner AP, Stitzel NO, Kathiresan S, Gabriel S, Barrett JC, Lehtimäki T, Laakso M, Groop L, Kaprio J, Perola M, McCarthy MI, Boehnke M, Altshuler DM, Lindgren CM, Hirschhorn JN, Metspalu A, Freimer NB, *et al*: Distribution and medical impact of loss-of-function variants in the Finnish founder population. *PLoS Genet* 2014, **10**:e1004494.
166. Sarantaus L, Huusko P, Eerola H, Launonen V, Vehmanen P, Rapakko K, Gillanders E, Syrjäkoski K, Kainu T, Vahteristo P, Krahe R, Paakkonen K, Hartikainen J, Blomqvist C, Loppinen T, Holli K, Ryyänen M, Butzow R, Borg A, Wasteson Arver B, Holmberg E, Mannermaa A, Kere J, Kallioniemi OP, Winqvist R, Nevanlinna H: Multiple founder effects and geographical clustering of BRCA1 and BRCA2 families in Finland. *Eur J Hum Genet* 2000, **8**:757-763.
167. Erkko H, Xia B, Nikkila J, Schleutker J, Syrjäkoski K, Mannermaa A, Kallioniemi A, Pylkas K, Karppinen SM, Rapakko K, Miron A, Sheng Q, Li G, Mattila H, Bell DW, Haber DA, Grip M, Reiman M, Jukkola-Vuorinen A, Mustonen A, Kere J, Aaltonen LA, Kosma VM, Kataja V, Soini Y, Drapkin RI, Livingston DM, Winqvist R: A recurrent mutation in PALB2 in Finnish cancer families. *Nature* 2007, **446**:316-319.
168. Vahteristo P, Bartkova J, Eerola H, Syrjäkoski K, Ojala S, Kilpivaara O, Tamminen A, Kononen J, Aittomäki K, Heikkilä P, Holli K, Blomqvist C, Bartek J, Kallioniemi OP, Nevanlinna H: A CHEK2 genetic variant contributing to a substantial fraction of familial breast cancer. *Am J Hum Genet* 2002, **71**:432-438.
169. Jakkula E, Rehnstrom K, Varilo T, Pietiläinen OP, Paunio T, Pedersen NL, deFaire U, Jarvelin MR, Saharinen J, Freimer N, Ripatti S, Purcell S, Collins A, Daly MJ, Palotie A, Peltonen L: The genome-wide patterns of variation expose significant substructure in a founder population. *Am J Hum Genet* 2008, **83**:787-794.
170. Kerminen S, Havulinna AS, Hellenthal G, Martin AR, Sarin AP, Perola M, Palotie A, Salomaa V, Daly MJ, Ripatti S, Pirinen M: Fine-Scale Genetic Structure in Finland. *G3 (Bethesda)* 2017, **7**:3459-3468.
171. Attard G, Parker C, Eeles RA, Schroder F, Tomlins SA, Tannock I, Drake CG, de Bono JS: Prostate cancer. *Lancet* 2016, **387**:70-82.
172. Eeles R, Goh C, Castro E, Bancroft E, Guy M, Al Olama AA, Easton D, Kote-Jarai Z: The genetic epidemiology of prostate cancer and its clinical implications. *Nat Rev Urol* 2014, **11**:18-31.
173. Ewing CM, Ray AM, Lange EM, Zuhlke KA, Robbins CM, Tembe WD, Wiley KE, Isaacs SD, Johng D, Wang Y, Bizon C, Yan G, Gielzak M, Partin AW, Shanmugam V, Izatt T, Sinari S, Craig DW, Zheng SL, Walsh PC, Montie JE, Xu J, Carpten JD, Isaacs WB, Cooney KA: Germline mutations in HOXB13 and prostate-cancer risk. *N Engl J Med* 2012, **366**:141-149.

174. Laitinen VH, Wahlfors T, Saaristo L, Rantapero T, Pelttari LM, Kilpivaara O, Laasanen SL, Kallioniemi A, Nevanlinna H, Aaltonen L, Vessella RL, Auvinen A, Visakorpi T, Tammela TL, Schleutker J: HOXB13 G84E mutation in Finland: population-based analysis of prostate, breast, and colorectal cancer risk. *Cancer Epidemiol Biomarkers Prev* 2013, **22**:452-460.
175. Kote-Jarai Z, Leongamornlert D, Saunders E, Tymrakiewicz M, Castro E, Mahmud N, Guy M, Edwards S, O'Brien L, Sawyer E, Hall A, Wilkinson R, Dadaev T, Goh C, Easton D, UKGPCS Collaborators, Goldgar D, Eeles R: BRCA2 is a moderate penetrance gene contributing to young-onset prostate cancer: implications for genetic testing in prostate cancer patients. *Br J Cancer* 2011, **105**:1230-1234.
176. Pritchard CC, Mateo J, Walsh MF, De Sarkar N, Abida W, Beltran H, Garofalo A, Gulati R, Carreira S, Eeles R, Elemento O, Rubin MA, Robinson D, Lonigro R, Hussain M, Chinnaiyan A, Vinson J, Filipenko J, Garraway L, Taplin ME, AlDubayan S, Han GC, Beightol M, Morrissey C, Nghiem B, Cheng HH, Montgomery B, Walsh T, Casadei S, Berger M, Zhang L, Zehir A, Vijai J, Scher HI, Sawyers C, Schultz N, Kantoff PW, Solit D, Robson M, Van Allen EM, Offit K, de Bono J, Nelson PS: Inherited DNA-Repair Gene Mutations in Men with Metastatic Prostate Cancer. *N Engl J Med* 2016, **375**:443-453.
177. Leongamornlert D, Mahmud N, Tymrakiewicz M, Saunders E, Dadaev T, Castro E, Goh C, Govindasami K, Guy M, O'Brien L, Sawyer E, Hall A, Wilkinson R, Easton D, UKGPCS Collaborators, Goldgar D, Eeles R, Kote-Jarai Z: Germline BRCA1 mutations increase prostate cancer risk. *Br J Cancer* 2012, **106**:1697-1701.
178. Al Olama AA, Kote-Jarai Z, Berndt SI, Conti DV, Schumacher F, Han Y, Benlloch S, Hazelett DJ, Wang Z, Saunders E, Leongamornlert D, Lindstrom S, Jugurnauth-Little S, Dadaev T, Tymrakiewicz M, Stram DO, Rand K, Wan P, Stram A, Sheng X, Pooler LC, Park K, Xia L, Tyrer J, Kolonel LN, Le Marchand L, Hoover RN, Machiela MJ, Yeager M, Burdette L, Chung CC, Hutchinson A, Yu K, Goh C, Ahmed M, Govindasami K, Guy M, Tammela TL, Auvinen A, Wahlfors T, Schleutker J, Visakorpi T, Leinonen KA, Xu J, Aly M, Donovan J, Travis RC, Key TJ, Siddiq A, Canzian F, *et al*: A meta-analysis of 87,040 individuals identifies 23 new susceptibility loci for prostate cancer. *Nat Genet* 2014, **46**:1103-1109.
179. Amin Al Olama A, Dadaev T, Hazelett DJ, Li Q, Leongamornlert D, Saunders EJ, Stephens S, Cieza-Borrella C, Whitmore I, Benlloch Garcia S, Giles GG, Southey MC, Fitzgerald L, Gronberg H, Wiklund F, Aly M, Henderson BE, Schumacher F, Haiman CA, Schleutker J, Wahlfors T, Tammela TL, Nordestgaard BG, Key TJ, Travis RC, Neal DE, Donovan JL, Hamdy FC, Pharoah P, Pashayan N, Khaw KT, Stanford JL, Thibodeau SN, McDonnell SK, Schaid DJ, Maier C, Vogel W, Luedeke M, Herkommer K, Kibel AS, Cybulski C, Wokolorczyk D, Kluzniak W, Cannon-Albright L, Brenner H, Butterbach K, Arndt V, Park JY, Sellers T, Lin HY, *et al*: Multiple novel prostate cancer susceptibility signals identified by fine-mapping of known risk loci among Europeans. *Hum Mol Genet* 2015, **24**:5589-5602.
180. Brenner H, Kloor M, Pox CP: Colorectal cancer. *Lancet* 2014, **383**:1490-1502.
181. Graff RE, Moller S, Passarelli MN, Witte JS, Skytthe A, Christensen K, Tan Q, Adami HO, Czene K, Harris JR, Pukkala E, Kaprio J, Giovannucci EL, Mucci LA, Hjelmborg JB:

Familial Risk and Heritability of Colorectal Cancer in the Nordic Twin Study of Cancer. *Clin Gastroenterol Hepatol* 2017, **15**:1256-1264.

182. Peters U, Bien S, Zubair N: Genetic architecture of colorectal cancer. *Gut* 2015, **64**:1623-1636.

183. Kinzler KW, Nilbert MC, Su LK, Vogelstein B, Bryan TM, Levy DB, Smith KJ, Preisinger AC, Hedge P, McKechnie D: Identification of FAP locus genes from chromosome 5q21. *Science* 1991, **253**:661-665.

184. Al-Tassan N, Chmiel NH, Maynard J, Fleming N, Livingston AL, Williams GT, Hodges AK, Davies DR, David SS, Sampson JR, Cheadle JP: Inherited variants of MYH associated with somatic G:C-->T:A mutations in colorectal tumors. *Nat Genet* 2002, **30**:227-232.

185. Palles C, Cazier JB, Howarth KM, Domingo E, Jones AM, Broderick P, Kemp Z, Spain SL, Guarino E, Salguero I, Sherborne A, Chubb D, Carvajal-Carmona LG, Ma Y, Kaur K, Dobbins S, Barclay E, Gorman M, Martin L, Kovac MB, Humphray S, CORGI Consortium, WGS500 Consortium, Lucassen A, Holmes CC, Bentley D, Donnelly P, Taylor J, Petridis C, Roylance R, Sawyer EJ, Kerr DJ, Clark S, Grimes J, Kearsey SE, Thomas HJ, McVean G, Houlston RS, Tomlinson I: Germline mutations affecting the proofreading domains of POLE and POLD1 predispose to colorectal adenomas and carcinomas. *Nat Genet* 2013, **45**:136-144.

186. Howe JR, Roth S, Ringold JC, Summers RW, Jarvinen HJ, Sistonen P, Tomlinson IP, Houlston RS, Bevan S, Mitros FA, Stone EM, Aaltonen LA: Mutations in the SMAD4/DPC4 gene in juvenile polyposis. *Science* 1998, **280**:1086-1088.

187. Howe JR, Bair JL, Sayed MG, Anderson ME, Mitros FA, Petersen GM, Velculescu VE, Traverso G, Vogelstein B: Germline mutations of the gene encoding bone morphogenetic protein receptor 1A in juvenile polyposis. *Nat Genet* 2001, **28**:184-187.

188. Chubb D, Broderick P, Frampton M, Kinnersley B, Sherborne A, Penegar S, Lloyd A, Ma YP, Dobbins SE, Houlston RS: Genetic diagnosis of high-penetrance susceptibility for colorectal cancer (CRC) is achievable for a high proportion of familial CRC by exome sequencing. *J Clin Oncol* 2015, **33**:426-432.

189. Zeng C, Matsuda K, Jia WH, Chang J, Kweon SS, Xiang YB, Shin A, Jee SH, Kim DH, Zhang B, Cai Q, Guo X, Long J, Wang N, Courtney R, Pan ZZ, Wu C, Takahashi A, Shin MH, Matsuo K, Matsuda F, Gao YT, Oh JH, Kim S, Jung KJ, Ahn YO, Ren Z, Li HL, Wu J, Shi J, Wen W, Yang G, Li B, Ji BT, Genetics and Epidemiology of Colorectal Cancer Consortium (GECCO), Brenner H, Schoen RE, Kury S, Colorectal Transdisciplinary (CORECT) Study, Gruber SB, Schumacher FR, Stenzel SL, Colon Cancer Family Registry (CCFR), Casey G, Hopper JL, Jenkins MA, Kim HR, Jeong JY, Park JW, Tajima K, *et al*: Identification of Susceptibility Loci and Genes for Colorectal Cancer Risk. *Gastroenterology* 2016, **150**:1633-1645.

190. Takata M, Sasaki MS, Tachiiri S, Fukushima T, Sonoda E, Schild D, Thompson LH, Takeda S: Chromosome instability and defective recombinational repair in knockout mutants of the five Rad51 paralogs. *Mol Cell Biol* 2001, **21**:2858-2866.

191. Masson JY, Tarsounas MC, Stasiak AZ, Stasiak A, Shah R, McIlwraith MJ, Benson FE, West SC: Identification and purification of two distinct complexes containing the five RAD51 paralogs. *Genes Dev* 2001, **15**:3296-3307.
192. Chun J, Buechelmaier ES, Powell SN: Rad51 Paralog Complexes BCDX2 and CX3 Act at Different Stages in the BRCA1-BRCA2-Dependent Homologous Recombination Pathway. *Mol Cell Biol* 2013, **33**:387-395.
193. Lin Z, Kong H, Nei M, Ma H: Origins and evolution of the recA/RAD51 gene family: evidence for ancient gene duplication and endosymbiotic gene transfer. *Proc Natl Acad Sci U S A* 2006, **103**:10328-10333.
194. Miller KA, Sawicka D, Barsky D, Albala JS: Domain mapping of the Rad51 paralog protein complexes. *Nucleic Acids Res* 2004, **32**:169-178.
195. Park JY, Singh TR, Nassar N, Zhang F, Freund M, Hanenberg H, Meetei AR, Andreassen PR: Breast cancer-associated missense mutants of the PALB2 WD40 domain, which directly binds RAD51C, RAD51 and BRCA2, disrupt DNA repair. *Oncogene* 2014, **33**:4803-4812.
196. Dosanjh MK, Collins DW, Fan W, Lennon GG, Albala JS, Shen Z, Schild D: Isolation and characterization of RAD51C, a new human member of the RAD51 family of related genes. *Nucleic Acids Res* 1998, **26**:1179-1184.
197. French CA, Tambini CE, Thacker J: Identification of functional domains in the RAD51L2 (RAD51C) protein and its requirement for gene conversion. *J Biol Chem* 2003, **278**:45445-45450.
198. Huang J, Huen MS, Kim H, Leung CC, Glover JN, Yu X, Chen J: RAD18 transmits DNA damage signalling to elicit homologous recombination repair. *Nat Cell Biol* 2009, **11**:592-603.
199. Badie S, Liao C, Thanasoula M, Barber P, Hill MA, Tarsounas M: RAD51C facilitates checkpoint signaling by promoting CHK2 phosphorylation. *J Cell Biol* 2009, **185**:587-600.
200. Somyajit K, Subramanya S, Nagaraju G: Distinct roles of FANCO/RAD51C protein in DNA damage signaling and repair: implications for Fanconi anemia and breast cancer susceptibility. *J Biol Chem* 2012, **287**:3366-3380.
201. Liu Y, Masson JY, Shah R, O'Regan P, West SC: RAD51C is required for Holliday junction processing in mammalian cells. *Science* 2004, **303**:243-246.
202. Renglin Lindh A, Schultz N, Saleh-Gohari N, Helleday T: RAD51C (RAD51L2) is involved in maintaining centrosome number in mitosis. *Cytogenet Genome Res* 2007, **116**:38-45.
203. Somyajit K, Saxena S, Babu S, Mishra A, Nagaraju G: Mammalian RAD51 paralogs protect nascent DNA at stalled forks and mediate replication restart. *Nucleic Acids Res* 2015, **43**:9835-9855.
204. Kuznetsov SG, Haines DC, Martin BK, Sharan SK: Loss of Rad51c leads to embryonic lethality and modulation of Trp53-dependent tumorigenesis in mice. *Cancer Res* 2009, **69**:863-872.

205. Bric A, Miething C, Bialucha CU, Scuoppo C, Zender L, Krasnitz A, Xuan Z, Zuber J, Wigler M, Hicks J, McCombie RW, Hemann MT, Hannon GJ, Powers S, Lowe SW: Functional identification of tumor-suppressor genes through an in vivo RNA interference screen in a mouse lymphoma model. *Cancer Cell* 2009, **16**:324-335.
206. Tumiati M, Hemmes A, Uusivirta S, Koopal S, Kankainen M, Lehtonen E, Kuznetsov SG: Loss of Rad51c accelerates tumorigenesis in sebaceous glands of Trp53-mutant mice. *J Pathol* 2015, **235**:136-146.
207. Smeenk G, de Groot AJ, Romeijn RJ, van Buul PP, Zdzienicka MZ, Mullenders LH, Pastink A, Godthelp BC: Rad51C is essential for embryonic development and haploinsufficiency causes increased DNA damage sensitivity and genomic instability. *Mutat Res* 2010, **689**:50-58.
208. Alayev A, Salamon RS, Manna S, Schwartz NS, Berman AY, Holz MK: Estrogen induces RAD51C expression and localization to sites of DNA damage. *Cell Cycle* 2016, **15**:3230-3239.
209. Ensembl genome browser, <http://www.ensembl.org/> [Accessed December 15, 2017]
210. Wiese C, Hinz JM, Tebbs RS, Nham PB, Urbin SS, Collins DW, Thompson LH, Schild D: Disparate requirements for the Walker A and B ATPase motifs of human RAD51D in homologous recombination. *Nucleic Acids Res* 2006, **34**:2833-2843.
211. Gruver AM, Miller KA, Rajesh C, Smiraldo PG, Kaliyaperumal S, Balder R, Stiles KM, Albala JS, Pittman DL: The ATPase motif in RAD51D is required for resistance to DNA interstrand crosslinking agents and interaction with RAD51C. *Mutagenesis* 2005, **20**:433-440.
212. Braybrooke JP, Li JL, Wu L, Caple F, Benson FE, Hickson ID: Functional interaction between the Bloom's syndrome helicase and the RAD51 paralog, RAD51L3 (RAD51D). *J Biol Chem* 2003, **278**:48357-48366.
213. Tarsounas M, Munoz P, Claas A, Smiraldo PG, Pittman DL, Blasco MA, West SC: Telomere maintenance requires the RAD51D recombination/repair protein. *Cell* 2004, **117**:337-347.
214. Smiraldo PG, Gruver AM, Osborn JC, Pittman DL: Extensive chromosomal instability in Rad51d-deficient mouse cells. *Cancer Res* 2005, **65**:2089-2096.
215. Ceballos SJ, Heyer WD: Functions of the Snf2/Swi2 family Rad54 motor protein in homologous recombination. *Biochim Biophys Acta* 2011, **1809**:509-523.
216. Mason JM, Dusad K, Wright WD, Grubb J, Budke B, Heyer WD, Connell PP, Weichselbaum RR, Bishop DK: RAD54 family translocases counter genotoxic effects of RAD51 in human tumor cells. *Nucleic Acids Res* 2015, **43**:3180-3196.
217. van Dijk EL, Auger H, Jaszczyszyn Y, Thermes C: Ten years of next-generation sequencing technology. *Trends Genet* 2014, **30**:418-426.
218. Graffeo R, Livraghi L, Pagani O, Goldhirsch A, Partridge AH, Garber JE: Time to incorporate germline multigene panel testing into breast and ovarian cancer patient care. *Breast Cancer Res Treat* 2016, **160**:393-410.

219. Kilpivaara O, Bartkova J, Eerola H, Syrjakoski K, Vahteristo P, Lukas J, Blomqvist C, Holli K, Heikkila P, Sauter G, Kallioniemi OP, Bartek J, Nevanlinna H: Correlation of CHEK2 protein expression and c.1100delC mutation status with tumor characteristics among unselected breast cancer patients. *Int J Cancer* 2005, **113**:575-580.
220. Fagerholm R, Hofstetter B, Tommiska J, Aaltonen K, Vrtel R, Syrjakoski K, Kallioniemi A, Kilpivaara O, Mannermaa A, Kosma VM, Uusitupa M, Eskelinen M, Kataja V, Aittomaki K, von Smitten K, Heikkila P, Lukas J, Holli K, Bartkova J, Blomqvist C, Bartek J, Nevanlinna H: NAD(P)H:quinone oxidoreductase 1 NQO1\*2 genotype (P187S) is a strong prognostic and predictive factor in breast cancer. *Nat Genet* 2008, **40**:844-853.
221. Eerola H, Blomqvist C, Pukkala E, Pyrhonen S, Nevanlinna H: Familial breast cancer in southern Finland: how prevalent are breast cancer families and can we trust the family history reported by patients? *Eur J Cancer* 2000, **36**:1143-1148.
222. Eerola H, Heikkila P, Tamminen A, Aittomaki K, Blomqvist C, Nevanlinna H: Histopathological features of breast tumours in BRCA1, BRCA2 and mutation-negative breast cancer families. *Breast Cancer Res* 2005, **7**:R93-100.
223. Tommiska J, Bartkova J, Heinonen M, Hautala L, Kilpivaara O, Eerola H, Aittomaki K, Hofstetter B, Lukas J, von Smitten K, Blomqvist C, Ristimaki A, Heikkila P, Bartek J, Nevanlinna H: The DNA damage signalling kinase ATM is aberrantly reduced or lost in BRCA1/BRCA2-deficient and ER/PR/ERBB2-triple-negative breast cancer. *Oncogene* 2008, **27**:2501-2506.
224. Matikainen MP, Sankila R, Schleutker J, Kallioniemi OP, Pukkala E: Nationwide cancer family ascertainment using Finnish Cancer Registry data on family names and places of birth for 35,761 prostate cancer patients. *Int J Cancer* 2000, **88**:307-312.
225. Aaltonen LA, Salovaara R, Kristo P, Canzian F, Hemminki A, Peltomaki P, Chadwick RB, Kaariainen H, Eskelinen M, Jarvinen H, Mecklin JP, de la Chapelle A: Incidence of hereditary nonpolyposis colorectal cancer and the feasibility of molecular screening for the disease. *N Engl J Med* 1998, **338**:1481-1487.
226. Salovaara R, Loukola A, Kristo P, Kaariainen H, Ahtola H, Eskelinen M, Harkonen N, Julkunen R, Kangas E, Ojala S, Tulikoura J, Valkamo E, Jarvinen H, Mecklin JP, Aaltonen LA, de la Chapelle A: Population-based molecular detection of hereditary nonpolyposis colorectal cancer. *J Clin Oncol* 2000, **18**:2193-2200.
227. Cingolani P, Platts A, Wang le L, Coon M, Nguyen T, Wang L, Land SJ, Lu X, Ruden DM: A program for annotating and predicting the effects of single nucleotide polymorphisms, SnpEff: SNPs in the genome of *Drosophila melanogaster* strain w1118; iso-2; iso-3. *Fly (Austin)* 2012, **6**:80-92.
228. Wang K, Li M, Hakonarson H: ANNOVAR: functional annotation of genetic variants from high-throughput sequencing data. *Nucleic Acids Res* 2010, **38**:e164.
229. Desmet FO, Hamroun D, Lalande M, Collod-Beroud G, Claustres M, Beroud C: Human Splicing Finder: an online bioinformatics tool to predict splicing signals. *Nucleic Acids Res* 2009, **37**:e67.

230. Yeo G, Burge CB: Maximum entropy modeling of short sequence motifs with applications to RNA splicing signals. *J Comput Biol* 2004, **11**:377-394.
231. Landrum MJ, Lee JM, Benson M, Brown GR, Chao C, Chitipiralla S, Gu B, Hart J, Hoffman D, Jang W, Karapetyan K, Katz K, Liu C, Maddipatla Z, Malheiro A, McDaniel K, Ovetsky M, Riley G, Zhou G, Holmes JB, Kattman BL, Maglott DR: ClinVar: improving access to variant interpretations and supporting evidence. *Nucleic Acids Res* 2018, **46**:D1062-D1067.
232. Stenson PD, Mort M, Ball EV, Evans K, Hayden M, Heywood S, Hussain M, Phillips AD, Cooper DN: The Human Gene Mutation Database: towards a comprehensive repository of inherited mutation data for medical research, genetic diagnosis and next-generation sequencing studies. *Hum Genet* 2017, **136**:665-677.
233. Lek M, Karczewski KJ, Minikel EV, Samocha KE, Banks E, Fennell T, O'Donnell-Luria AH, Ware JS, Hill AJ, Cummings BB, Tukiainen T, Birnbaum DP, Kosmicki JA, Duncan LE, Estrada K, Zhao F, Zou J, Pierce-Hoffman E, Berghout J, Cooper DN, Deflaux N, DePristo M, Do R, Flannick J, Fromer M, Gauthier L, Goldstein J, Gupta N, Howrigan D, Kiezun A, Kurki MI, Moonshine AL, Natarajan P, Orozco L, Peloso GM, Poplin R, Rivas MA, Ruano-Rubio V, Rose SA, Ruderfer DM, Shakir K, Stenson PD, Stevens C, Thomas BP, Tiao G, Tusie-Luna MT, Weisburd B, Won HH, Yu D, Altshuler DM, *et al*: Analysis of protein-coding genetic variation in 60,706 humans. *Nature* 2016, **536**:285-291.
234. The Exome Aggregation Consortium (ExAC), <http://exac.broadinstitute.org/> [Accessed January 1, 2018]
235. The Genome Aggregation Database (gnomAD), <http://gnomad.broadinstitute.org/> [Accessed January 1, 2018]
236. Dicks E, Song H, Ramus SJ, Oudenhove EV, Tyrer JP, Intermaggio MP, Kar S, Harrington P, Bowtell DD, Group AS, Cicek MS, Cunningham JM, Fridley BL, Alsop J, Jimenez-Linan M, Piskorz A, Goranova T, Kent E, Siddiqui N, Paul J, Crawford R, Poblete S, Lele S, Sucheston-Campbell L, Moysich KB, Sieh W, McGuire V, Lester J, Odunsi K, Whittemore AS, Bogdanova N, Durst M, Hillemanns P, Karlan BY, Gentry-Maharaj A, Menon U, Tischkowitz M, Levine D, Brenton JD, Dork T, Goode EL, Gayther SA, Pharoah DPP: Germline whole exome sequencing and large-scale replication identifies FANCM as a likely high grade serous ovarian cancer susceptibility gene. *Oncotarget* 2017, **8**:50930-50940.
237. Vuorela M, Pylkas K, Hartikainen JM, Sundfeldt K, Lindblom A, von Wachenfeldt Wappling A, Haanpaa M, Puistola U, Rosengren A, Anttila M, Kosma VM, Mannermaa A, Winqvist R: Further evidence for the contribution of the RAD51C gene in hereditary breast and ovarian cancer susceptibility. *Breast Cancer Res Treat* 2011, **130**:1003-1010.
238. Walsh T, Casadei S, Lee MK, Pennil CC, Nord AS, Thornton AM, Roeb W, Agnew KJ, Stray SM, Wickramanayake A, Norquist B, Pennington KP, Garcia RL, King MC, Swisher EM: Mutations in 12 genes for inherited ovarian, fallopian tube, and peritoneal carcinoma identified by massively parallel sequencing. *Proc Natl Acad Sci U S A* 2011, **108**:18032-18037.



239. Osorio A, Endt D, Fernandez F, Eirich K, de la Hoya M, Schmutzler R, Caldes T, Meindl A, Schindler D, Benitez J: Predominance of pathogenic missense variants in the RAD51C gene occurring in breast and ovarian cancer families. *Hum Mol Genet* 2012, **21**:2889-2898.
240. Thompson ER, Boyle SE, Johnson J, Ryland GL, Sawyer S, Choong DY, kConFab, Chenevix-Trench G, Trainer AH, Lindeman GJ, Mitchell G, James PA, Campbell IG: Analysis of RAD51C germline mutations in high-risk breast and ovarian cancer families and ovarian cancer patients. *Hum Mutat* 2012, **33**:95-99.
241. Coulet F, Fajac A, Colas C, Eyries M, Dion-Miniere A, Rouzier R, Uzan S, Lefranc JP, Carbonnel M, Cornelis F, Cortez A, Soubrier F: Germline RAD51C mutations in ovarian cancer susceptibility. *Clin Genet* 2013, **83**:332-336.
242. Golmard L, Caux-Moncoutier V, Davy G, Al Ageeli E, Poirot B, Tirapo C, Michaux D, Barbaroux C, d'Enghien CD, Nicolas A, Castera L, Sastre-Garau X, Stern MH, Houdayer C, Stoppa-Lyonnet D: Germline mutation in the RAD51B gene confers predisposition to breast cancer. *BMC Cancer* 2013, **13**:484-2407-13-484.
243. Blanco A, Gutierrez-Enriquez S, Santamarina M, Montalban G, Bonache S, Balmana J, Carracedo A, Diez O, Vega A: RAD51C germline mutations found in Spanish site-specific breast cancer and breast-ovarian cancer families. *Breast Cancer Res Treat* 2014, **147**:133-143.
244. Rashid MU, Muhammad N, Faisal S, Amin A, Hamann U: Deleterious RAD51C germline mutations rarely predispose to breast and ovarian cancer in Pakistan. *Breast Cancer Res Treat* 2014, **145**:775-784.
245. Castera L, Krieger S, Rousselin A, Legros A, Baumann JJ, Bruet O, Brault B, Fouillet R, Goardon N, Letac O, Baert-Desurmont S, Tinat J, Bera O, Dugast C, Berthet P, Polycarpe F, Layet V, Hardouin A, Frebourg T, Vaur D: Next-generation sequencing for the diagnosis of hereditary breast and ovarian cancer using genomic capture targeting multiple candidate genes. *Eur J Hum Genet* 2014, **22**:1305-1313.
246. Janatova M, Soukupova J, Stribrna J, Kleiblova P, Vocka M, Boudova P, Kleibl Z, Pohlreich P: Mutation Analysis of the RAD51C and RAD51D Genes in High-Risk Ovarian Cancer Patients and Families from the Czech Republic. *PLoS One* 2015, **10**:e0127711.
247. Song H, Dicks E, Ramus SJ, Tyrer JP, Intermaggio MP, Hayward J, Edlund CK, Conti D, Harrington P, Fraser L, Philpott S, Anderson C, Rosenthal A, Gentry-Maharaj A, Bowtell DD, Alsop K, Cicek MS, Cunningham JM, Fridley BL, Alsop J, Jimenez-Linan M, Hogdall E, Hogdall CK, Jensen A, Kjaer SK, Lubinski J, Huzarski T, Jakubowska A, Gronwald J, Poblete S, Lele S, Sucheston-Campbell L, Moysich KB, Odunsi K, Goode EL, Menon U, Jacobs IJ, Gayther SA, Pharoah PD: Contribution of Germline Mutations in the RAD51B, RAD51C, and RAD51D Genes to Ovarian Cancer in the Population. *J Clin Oncol* 2015, **33**:2901-2907.
248. Jonson L, Ahlborn LB, Steffensen AY, Djursby M, Ejlersen B, Timshel S, Nielsen FC, Gerdes AM, Hansen TV: Identification of six pathogenic RAD51C mutations via mutational screening of 1228 Danish individuals with increased risk of hereditary breast and/or ovarian cancer. *Breast Cancer Res Treat* 2016, **155**:215-222.

249. Osher DJ, De Leeneer K, Michils G, Hamel N, Tomiak E, Poppe B, Leunen K, Legius E, Shuen A, Smith E, Arseneau J, Tonin P, Matthijs G, Claes K, Tischkowitz MD, Foulkes WD: Mutation analysis of RAD51D in non-BRCA1/2 ovarian and breast cancer families. *Br J Cancer* 2012, **106**:1460-1463.
250. Wickramanayake A, Bernier G, Pennil C, Casadei S, Agnew KJ, Stray SM, Mandell J, Garcia RL, Walsh T, King MC, Swisher EM: Loss of function germline mutations in RAD51D in women with ovarian carcinoma. *Gynecol Oncol* 2012, **127**:552-555.
251. Thompson ER, Rowley SM, Sawyer S, kConfab, Eccles DM, Trainer AH, Mitchell G, James PA, Campbell IG: Analysis of RAD51D in ovarian cancer patients and families with a history of ovarian or breast cancer. *PLoS One* 2013, **8**:e54772.
252. Gutierrez-Enriquez S, Bonache S, de Garibay GR, Osorio A, Santamarina M, Ramon y Cajal T, Esteban-Cardenosa E, Tenes A, Yanowsky K, Barroso A, Montalban G, Blanco A, Cornet M, Gadea N, Infante M, Caldes T, Diaz-Rubio E, Balmana J, Lasa A, Vega A, Benitez J, de la Hoya M, Diez O: About 1% of the breast and ovarian Spanish families testing negative for BRCA1 and BRCA2 are carriers of RAD51D pathogenic variants. *Int J Cancer* 2014, **134**:2088-2097.
253. Rivera B, Di Iorio M, Frankum J, Nadaf J, Fahiminiya S, Arcand SL, Burk DL, Grapton D, Tomiak E, Hastings V, Hamel N, Wagener R, Aleynikova O, Giroux S, Hamdan FF, Dionne-Laporte A, Zogopoulos G, Rousseau F, Berghuis AM, Provencher D, Rouleau GA, Michaud JL, Mes-Masson AM, Majewski J, Bens S, Siebert R, Narod SA, Akbari MR, Lord CJ, Tonin PN, Orthwein A, Foulkes WD: Functionally Null RAD51D Missense Mutation Associates Strongly with Ovarian Carcinoma. *Cancer Res* 2017, **77**:4517-4529.
254. Norquist BM, Harrell MI, Brady MF, Walsh T, Lee MK, Gulsuner S, Bernards SS, Casadei S, Yi Q, Burger RA, Chan JK, Davidson SA, Mannel RS, DiSilvestro PA, Lankes HA, Ramirez NC, King MC, Swisher EM, Birrer MJ: Inherited Mutations in Women With Ovarian Carcinoma. *JAMA Oncol* 2016, **2**:482-490.
255. Lilyquist J, LaDuca H, Polley E, Davis BT, Shimelis H, Hu C, Hart SN, Dolinsky JS, Couch FJ, Goldgar DE: Frequency of mutations in a large series of clinically ascertained ovarian cancer cases tested on multi-gene panels compared to reference controls. *Gynecol Oncol* 2017, **147**:375-380.
256. Couch FJ, Hart SN, Sharma P, Toland AE, Wang X, Miron P, Olson JE, Godwin AK, Pankratz VS, Olswold C, Slettedahl S, Hallberg E, Guidugli L, Davila JI, Beckmann MW, Janni W, Rack B, Ekici AB, Slamon DJ, Konstantopoulou I, Fostira F, Vratimos A, Fountzilas G, Peltari LM, Tapper WJ, Durcan L, Cross SS, Pilarski R, Shapiro CL, Klemp J, Yao S, Garber J, Cox A, Brauch H, Ambrosone C, Nevanlinna H, Yannoukakos D, Slager SL, Vachon CM, Eccles DM, Fasching PA: Inherited mutations in 17 breast cancer susceptibility genes among a large triple-negative breast cancer cohort unselected for family history of breast cancer. *J Clin Oncol* 2015, **33**:304-311.
257. Buys SS, Sandbach JF, Gammon A, Patel G, Kidd J, Brown KL, Sharma L, Saam J, Lancaster J, Daly MB: A study of over 35,000 women with breast cancer tested with a 25-gene panel of hereditary cancer genes. *Cancer* 2017, **123**:1721-1730.

258. Couch FJ, Shimelis H, Hu C, Hart SN, Polley EC, Na J, Hallberg E, Moore R, Thomas A, Lilyquist J, Feng B, McFarland R, Pesaran T, Huether R, LaDuca H, Chao EC, Goldgar DE, Dolinsky JS: Associations Between Cancer Predisposition Testing Panel Genes and Breast Cancer. *JAMA Oncol* 2017, **3**:1190-1196.
259. Auranen A, Grenman S, Makinen J, Pukkala E, Sankila R, Salmi T: Borderline ovarian tumors in Finland: epidemiology and familial occurrence. *Am J Epidemiol* 1996, **144**:548-553.
260. Gevensleben H, Bossung V, Meindl A, Wappenschmidt B, de Gregorio N, Osorio A, Romero A, Buettner R, Markiefka B, Schmutzler RK: Pathological features of breast and ovarian cancers in RAD51C germline mutation carriers. *Virchows Arch* 2014, **465**:365-369.
261. Min A, Im SA, Yoon YK, Song SH, Nam HJ, Hur HS, Kim HP, Lee KH, Han SW, Oh DY, Kim TY, O'Connor MJ, Kim WH, Bang YJ: RAD51C-deficient cancer cells are highly sensitive to the PARP inhibitor olaparib. *Mol Cancer Ther* 2013, **12**:865-877.
262. Somyajit K, Mishra A, Jameei A, Nagaraju G: Enhanced non-homologous end joining contributes toward synthetic lethality of pathological RAD51C mutants with poly (ADP-ribose) polymerase (PARP). *Carcinogenesis* 2015, **36**:13-24.
263. Klein AP: Genetic susceptibility to pancreatic cancer. *Mol Carcinog* 2012, **51**:14-24.
264. Romero A, Perez-Segura P, Tosar A, Garcia-Saenz JA, Diaz-Rubio E, Caldes T, de la Hoya M: A HRM-based screening method detects RAD51C germ-line deleterious mutations in Spanish breast and ovarian cancer families. *Breast Cancer Res Treat* 2011, **129**:939-946.
265. Yurgelun MB, Allen B, Kaldate RR, Bowles KR, Judkins T, Kaushik P, Roa BB, Wenstrup RJ, Hartman AR, Syngal S: Identification of a Variety of Mutations in Cancer Predisposition Genes in Patients With Suspected Lynch Syndrome. *Gastroenterology* 2015, **149**:604-13.e20.
266. Pearlman R, Frankel WL, Swanson B, Zhao W, Yilmaz A, Miller K, Bacher J, Bigley C, Nelsen L, Goodfellow PJ, Goldberg RM, Paskett E, Shields PG, Freudenheim JL, Stanich PP, Lattimer I, Arnold M, Liyanarachchi S, Kalady M, Heald B, Greenwood C, Paquette I, Prues M, Draper DJ, Lindeman C, Kuebler JP, Reynolds K, Brell JM, Shaper AA, Mahesh S, Buie N, Weeman K, Shine K, Haut M, Edwards J, Bastola S, Wickham K, Khanduja KS, Zacks R, Pritchard CC, Shirts BH, Jacobson A, Allen B, de la Chapelle A, Hampel H, Ohio Colorectal Cancer Prevention Initiative Study Group: Prevalence and Spectrum of Germline Cancer Susceptibility Gene Mutations Among Patients With Early-Onset Colorectal Cancer. *JAMA Oncol* 2017, **3**:464-471.
267. Tung N, Battelli C, Allen B, Kaldate R, Bhatnagar S, Bowles K, Timms K, Garber JE, Herold C, Ellisen L, Krejdovsky J, DeLeonardis K, Sedgwick K, Soltis K, Roa B, Wenstrup RJ, Hartman AR: Frequency of mutations in individuals with breast cancer referred for BRCA1 and BRCA2 testing using next-generation sequencing with a 25-gene panel. *Cancer* 2015, **121**:25-33.

268. Yablonski-Peretz T, Paluch-Shimon S, Gutman LS, Kaplan Y, Dvir A, Barnes-Kedar I, Kadouri L, Semenisty V, Efrat N, Neiman V, Glasser Y, Michaelson-Cohen R, Katz L, Kaufman B, Golan T, Reish O, Hubert A, Safra T, Yaron Y, Friedman E: Screening for germline mutations in breast/ovarian cancer susceptibility genes in high-risk families in Israel. *Breast Cancer Res Treat* 2016, **155**:133-138.
269. Lin PH, Kuo WH, Huang AC, Lu YS, Lin CH, Kuo SH, Wang MY, Liu CY, Cheng FT, Yeh MH, Li HY, Yang YH, Hsu YH, Fan SC, Li LY, Yu SL, Chang KJ, Chen PL, Ni YH, Huang CS: Multiple gene sequencing for risk assessment in patients with early-onset or familial breast cancer. *Oncotarget* 2016, **7**:8310-8320.
270. Kraus C, Hoyer J, Vasileiou G, Wunderle M, Lux MP, Fasching PA, Krumbiegel M, Uebe S, Reuter M, Beckmann MW, Reis A: Gene panel sequencing in familial breast/ovarian cancer patients identifies multiple novel mutations also in genes others than BRCA1/2. *Int J Cancer* 2017, **140**:95-102.
271. Tedaldi G, Tebaldi M, Zampiga V, Danesi R, Arcangeli V, Ravegnani M, Cangini I, Pirini F, Petracci E, Rocca A, Falcini F, Amadori D, Calistri D: Multiple-gene panel analysis in a case series of 255 women with hereditary breast and ovarian cancer. *Oncotarget* 2017, **8**:47064-47075.
272. Thompson ER, Rowley SM, Li N, McInerney S, Devereux L, Wong-Brown MW, Trainer AH, Mitchell G, Scott RJ, James PA, Campbell IG: Panel Testing for Familial Breast Cancer: Calibrating the Tension Between Research and Clinical Care. *J Clin Oncol* 2016, **34**:1455-1459.
273. Li J, Meeks H, Feng BJ, Healey S, Thorne H, Makunin I, Ellis J, kConFab Investigators, Campbell I, Southey M, Mitchell G, Clouston D, Kirk J, Goldgar D, Chenevix-Trench G: Targeted massively parallel sequencing of a panel of putative breast cancer susceptibility genes in a large cohort of multiple-case breast and ovarian cancer families. *J Med Genet* 2016, **53**:34-42.
274. Siolek M, Cybulski C, Gasiior-Perczak D, Kowalik A, Kozak-Klonowska B, Kowalska A, Chlopek M, Kluzniak W, Wokolorczyk D, Palyga I, Walczyk A, Lizis-Kolus K, Sun P, Lubinski J, Narod SA, Gozdz S: CHEK2 mutations and the risk of papillary thyroid cancer. *Int J Cancer* 2015, **137**:548-552.
275. Tok Celebi J, Chen FF, Zhang H, Ping XL, Tsou HC, Peacocke M: Identification of PTEN mutations in five families with Bannayan-Zonana syndrome. *Exp Dermatol* 1999, **8**:134-139.
276. Poli T, Lagana F, Caradonna L, Gobbi R, Corradi D, Sesenna E: Primary orbital liposarcoma in Li-Fraumeni cancer family syndrome: a case report. *Tumori* 2005, **91**:96-100.
277. Monti P, Perfumo C, Bisio A, Ciribilli Y, Menichini P, Russo D, Umbach DM, Resnick MA, Inga A, Fronza G: Dominant-negative features of mutant TP53 in germline carriers have limited impact on cancer outcomes. *Mol Cancer Res* 2011, **9**:271-279.

278. Melhem-Bertrandt A, Bojadzieva J, Ready KJ, Obeid E, Liu DD, Gutierrez-Barrera AM, Litton JK, Olopade OI, Hortobagyi GN, Strong LC, Arun BK: Early onset HER2-positive breast cancer is associated with germline TP53 mutations. *Cancer* 2012, **118**:908-913.
279. Cybulski C, Gorski B, Huzarski T, Byrski T, Gronwald J, Debniak T, Wokolorczyk D, Jakubowska A, Serrano-Fernandez P, Dork T, Narod SA, Lubinski J: Effect of CHEK2 missense variant I157T on the risk of breast cancer in carriers of other CHEK2 or BRCA1 mutations. *J Med Genet* 2009, **46**:132-135.
280. Adank MA, Jonker MA, Kluijdt I, van Mil SE, Oldenburg RA, Mooi WJ, Hogervorst FB, van den Ouweland AM, Gille JJ, Schmidt MK, van der Vaart AW, Meijers-Heijboer H, Waisfisz Q: CHEK2\*1100delC homozygosity is associated with a high breast cancer risk in women. *J Med Genet* 2011, **48**:860-863.
281. Turnbull C, Seal S, Renwick A, Warren-Perry M, Hughes D, Elliott A, Pernet D, Peock S, Adlard JW, Barwell J, Berg J, Brady AF, Brewer C, Brice G, Chapman C, Cook J, Davidson R, Donaldson A, Douglas F, Greenhalgh L, Henderson A, Izatt L, Kumar A, Lalloo F, Miedzybrodzka Z, Morrison PJ, Paterson J, Porteous M, Rogers MT, Shanley S, Walker L, Breast Cancer Susceptibility Collaboration (UK), EMBRACE, Ahmed M, Eccles D, Evans DG, Donnelly P, Easton DF, Stratton MR, Rahman N: Gene-gene interactions in breast cancer susceptibility. *Hum Mol Genet* 2012, **21**:958-962.
282. Lincoln SE, Kobayashi Y, Anderson MJ, Yang S, Desmond AJ, Mills MA, Nilsen GB, Jacobs KB, Monzon FA, Kurian AW, Ford JM, Ellisen LW: A Systematic Comparison of Traditional and Multigene Panel Testing for Hereditary Breast and Ovarian Cancer Genes in More Than 1000 Patients. *J Mol Diagn* 2015, **17**:533-544.
283. Manchanda R, Patel S, Gordeev VS, Antoniou AC, Smith S, Lee A, Hopper JL, MacInnis RJ, Turnbull C, Ramus SJ, Gayther SA, Pharoah PDP, Menon U, Jacobs I, Legood R: Cost-effectiveness of Population-Based BRCA1, BRCA2, RAD51C, RAD51D, BRIP1, PALB2 Mutation Testing in Unselected General Population Women. *J Natl Cancer Inst* 2018, doi: 10.1093/jnci/djx265.
284. Hackmann K, Kuhlee F, Betcheva-Krajcir E, Kahlert AK, Mackenroth L, Klink B, Di Donato N, Tzschach A, Kast K, Wimberger P, Schrock E, Rump A: Ready to clone: CNV detection and breakpoint fine-mapping in breast and ovarian cancer susceptibility genes by high-resolution array CGH. *Breast Cancer Res Treat* 2016, **159**:585-590.
285. Schnurbein G, Hauke J, Wappenschmidt B, Weber-Lassalle N, Engert S, Hellebrand H, Garbes L, Becker A, Neidhardt G, Rhiem K, Meindl A, Schmutzler RK, Hahnen E: RAD51C deletion screening identifies a recurrent gross deletion in breast cancer and ovarian cancer families. *Breast Cancer Res* 2013, **15**:R120.
286. HUSLAB Tutkimusohjekirja, Periytyvä munasarjasyöpäalttiis, <https://huslab.fi/ohjekirja/21376.html>, updated 27.11.2017 [Accessed February 12, 2018]
287. HUSLAB Tutkimusohjekirja, Periytyvä rintaja munasarjasyöpäalttiis, <https://huslab.fi/ohjekirja/22059.html>, updated 27.11.2017 [Accessed February 12, 2018]

## References

288. Eccles DM, Balmana J, Clune J, Ehlken B, Gohlke A, Hirst C, Potter D, Schroeder C, Tyczynski JE, Gomez Garcia EB: Selecting Patients with Ovarian Cancer for Germline BRCA Mutation Testing: Findings from Guidelines and a Systematic Literature Review. *Adv Ther* 2016, **33**:129-150.
289. Harter P, Hauke J, Heitz F, Reuss A, Kommos S, Marme F, Heimbach A, Prieske K, Richters L, Burges A, Neidhardt G, de Gregorio N, El-Balat A, Hilpert F, Meier W, Kimmig R, Kast K, Sehouli J, Baumann K, Jackisch C, Park-Simon TW, Hanker L, Krober S, Pfisterer J, Gevensleben H, Schnelzer A, Dietrich D, Neunhoffer T, Krockenberger M, Brucker SY, Nurnberg P, Thiele H, Altmuller J, Lamla J, Elser G, du Bois A, Hahnen E, Schmutzler R: Prevalence of deleterious germline variants in risk genes including BRCA1/2 in consecutive ovarian cancer patients (AGO-TR-1). *PLoS One* 2017, **12**:e0186043.
290. Sopik V, Akbari MR, Narod SA: Genetic testing for RAD51C mutations: in the clinic and community. *Clin Genet* 2015, **88**:303-312.
291. FINGOG: **Gynekologisen syövän kelpohoitosuositus**. 2018.
292. NICE. Clinical Guideline [CG164] - Familial breast cancer, <https://www.nice.org.uk/Guidance/CG164> [Accessed February 20, 2018]
293. National Comprehensive Cancer Network (NCCN) Clinical Practice Guidelines in Oncology: Genetic/familial high-risk assessment: breast and ovarian., <https://www.nccn.org>, updated 3.10.2017 [Accessed February 20, 2018]