

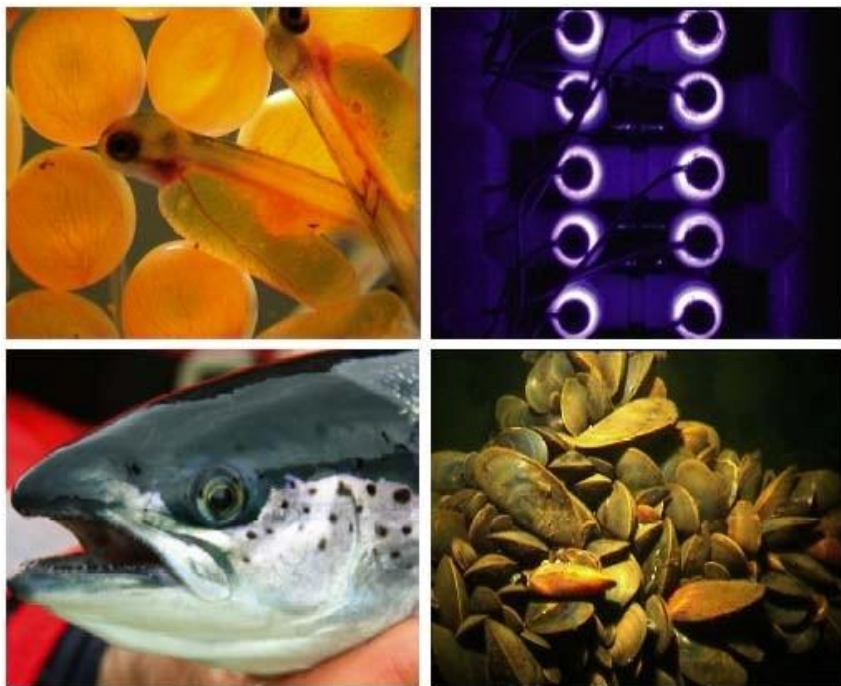

SARFSP011 - Technical Considerations of closed containment sea pen production for some life stages of salmonids



**A REPORT COMMISSIONED BY SARF
AND PREPARED BY**

The Institute of Aquaculture, University of Stirling

Published by the: Scottish Aquaculture Research Forum (SARF)

This report is available at: <http://www.sarf.org.uk>

Dissemination Statement

This publication may be re-used free of charge in any format or medium. It may only be reused accurately and not in a misleading context. All material must be acknowledged as SARF copyright and use of it must give the title of the source publication. Where third party copyright material has been identified, further use of that material requires permission from the copyright holders concerned.

Disclaimer

The opinions expressed in this report do not necessarily reflect the views of SARF and SARF is not liable for the accuracy of the information provided or responsible for any use of the content.

Suggested Citation:

Stirling Aquaculture (2015). Technical Considerations of closed containment sea pen production for some life stages of salmonids. A report produced by the Institute of Aquaculture, University of Stirling for the Scottish Aquaculture Research Forum (SARF) <http://www.sarf.org.uk/>

Title: Technical Considerations of closed containment sea pen production for some life stages of salmonids

ISBN: 978-1-907266-83-6

First published: March 2019

© SARF

SARF SP011 Technical Considerations of closed containment sea pen production for some life stages of salmonids

Scottish Aquaculture Research Forum
December 2018



SARF SP011 Technical Considerations of closed containment sea pen production for some life stages of salmonids

December 2018



Photo source: Cermaq (CCS in Horsvågen, Norway, constructed in partnership with Botngaard AS and Serge Ferrari)

Document Information

Document History and Authorisation		
Title	SARF SP011 Technical Considerations of closed containment sea pen production for some life stages of salmonids	
	[Type the document subtitle]	
Commissioned by	Scottish Aquaculture Research Forum	
Issue date	December 2018	
Document ref		
Project no		
Date	Version	Revision Details
12/12/2018	1	First draft
23/01/2019	2	Update to first draft including minor corrections and addition of missing references
16/02/2019	3	Minor edits to Executive Summary

Prepared (PM)	Approved (QM)	Authorised (PD)
"[Type name]"	"[Type name]"	"[Type name]"
"[Signature Placement]"	"[Signature Placement]"	"[Signature Placement]"

Suggested Citation

Stirling Aquaculture (2015). SARF SP011 Technical Considerations of closed containment sea pen production for some life stages of salmonids. A report produced by the Institute of Aquaculture, University of Stirling for the Scottish Aquaculture Research Forum, December 2018.

Contributing Authors

R Clarke, D Maitland, J Bostock,

Notice

The contents of this report reflect the knowledge and opinions of the report authors at the time of writing. Nothing in the report should be construed to be the official opinion of the University of Stirling or the Scottish Aquaculture Research Forum. The report is intended to be a general review of sea-based closed containment aquaculture system technologies and their potential use in the Scottish salmonid aquaculture sector. No part of the report should be taken as advice either for or against investment in any aspect of the sector. In this case, independent expert advice that examines specific proposals on their own merits is strongly recommended. The report authors, and Scottish Aquaculture Research Forum accept no liability for any use that is made of the information in this report. Whilst due care has been taken in the collation, selection and presentation of information in the report, no warranty is given as to its completeness, accuracy or future validity.

The copyright holder for this report is the Scottish Aquaculture Research Forum other than for photographs or diagrams where copyright may be held by third parties. No use or reproduction for commercial purposes are allowed.

Institute of Aquaculture, University of Stirling

Stirling, FK9 4LA, United Kingdom

T: +44 (0) 1786 467878 W: <http://www.aqua.stir.ac.uk>

Executive Summary

We have investigated the technical and economic use of a closed containment sea pen nursery system for production of larger (*circa* 1 kg) fish for stocking in conventional cage systems with a view to reducing the duration of the marine on-growing phase in conventional open cages. This modified production strategy would reduce the time of exposure to sea lice, allow the capture of some of the solid waste from the culture operation and potentially allow more efficient use of on-growing sites as the rate of throughput in those sites could be substantially increased.

In the last 5 years or so, there has been considerable activity, mainly in Norway, concerning the development of novel marine aquaculture systems with a focus on reducing the environmental impact of marine fish farming and enabling marine aquaculture to move further offshore. We have reviewed activity which has focused on the development of closed containment systems, in particular as may be used as "Nurseries" for the early stages of marine production of salmon and marine trout.

We have identified three closed containment systems which are apparently commercially available and a further ten systems which are at reasonably advanced stages of development and testing. A variety of different materials are used for the containment system including concrete, steel, GRP and flexible fabric. With the notable exception of one system (Lerøy Preline) most developments have adopted a similar design approach in that the CCS is a modified cage system, with the containment structure replacing the conventional open net and oxygen being supplied to the enclosed fish by means of a pumped water supply.

One of the most important potential benefits of the use of CCSs is that the water supply can be pumped from deep water, sufficient to exclude sea lice from the inflow ($\sim > 25\text{m}$). Although there are few objective scientific studies which confirm this, theoretical modelling of potential sea lice distribution gives support to the assumption and the practical experience reported from most commercial-scale trials is very positive, with, in most cases, no evidence of sea lice in the systems.

We have carried out an analysis of the potential cost-savings attributable to fewer lice treatments through the incorporation of a CCS nursery stage in the production cycle, based upon the frequency of treatments reported from Scottish production sites at various times in the production cycle. We have derived a value for cost-saving of between £0.12 and £0.17 per kg of salmon produced.

We have modelled potential operating strategies using floating CCS nurseries and have found that in the extreme case that all current salmon production adopted this strategy, the output from existing on-growing sites could be increased by up to 70%. Implementation of this approach would require suitable sites for the CCS nurseries to be identified and developed. For the theoretical assumption of 100% provision of the existing on-growing sites from nurseries, 35 sites for groups of 10, 80m circular CCSs or equivalent would be needed. By contrast, to achieve the equivalent increase in production from conventional methods would require a further 60 deep and well-flushed sites large enough to accommodate 12 x 120 circular cages or equivalent.

Despite the current progress in the design and testing of CCSs, there is little progress on the development of systems to collect, process and dispose of the waste feed and faeces which can be collected from CCSs. We have proposed a model for a simple system whereby 80% of solid wastes are captured by settling to a sump, then partially de-watered on the floating CCS and then transported to a land-based facility for further drying before disposal by incineration (potentially with energy recovery), composting, anaerobic digestion or landfill.

We have used this model of waste capture and treatment to conduct a financial analysis of the process. We have derived operating costs of the full waste processing and disposal process of £0.11 to £0.15 (depending on the disposal process used) per 1 kg post-smolt produced, including the costs for appropriate regulatory consents. The capital costs of systems were calculated from unit prices supplied by commercial providers. In order to express capital costs in some useful way, that is by relating them to production costs, we used a straight-line depreciation allowance over what was considered to be typically representative period for each component in order to derive an annual depreciation allowance which was then allocated to the system production by expressing it in terms of total depreciation per post-smolt produced. We derived capital costs for waste treatment and disposal of £0.21 to £0.23 per post-smolt, thereby giving a total cost for waste capture, treatment and disposal of £0.32 - £0.36 per post-smolt produced.

We have calculated the operating costs of a CCS unit in terms of the additional costs to be added to the costs of operating a conventional system. As we derived costs for waste capture, treatment and disposal as a separate exercise, the additional CCS operating costs comprise mainly energy costs for pumping the water supply through the CCS. We have also allowed for additional labour, mainly for the maintenance and operation of the increased level of mechanical and electrical equipment compared with a conventional cage system, as well as the cost of an additional well boat transfer (£0.21 per post-smolt). We derived additional operating costs for the CCS system (excluding waste costs but including the additional well boat transfer) of £0.66 per post-smolt produced.

We have used a financial model to express the additional capital costs of a CCS unit, compared with a conventional cage system, in terms of depreciation allowance per post-smolt produced. System costs were derived in two ways; first, for two cases we were able to obtain indicative prices for CCS units from commercial suppliers (Botngaard and Aquafarm) and we adjusted these values *pro rata* to a model standard size unit in order to allow direct comparison between systems. Second, working with a group of Scottish equipment suppliers, we conducted outline design exercises for three different types of CCS system and produced estimates of costs for complete systems (hence a theoretical commercial price for a standardised sized unit). Our derived costs did not include a service barge and feeder system as these were regarded as common to all systems including conventional systems. Allowances were made for additional mooring costs, which varied according to the type of system used, and for up-grading of power supply, distribution and control systems to account for the additional power supply to the CCS systems.

The derived system costs ranged from £530k to £6m for a 6,000m³ system. The two indicative prices from commercial suppliers were adjusted (for the purpose of comparison of the standard unit) to ~£1.4m for the Aquafarm GRP unit and ~£1m for the Botngaard system. When expressed as capital

depreciation allowance per post-smolt produced the derived additional costs were £0.61 (Aquafarm) and £1.44 (Botngaard).

In summary, we used a financial model to express the total additional costs to produce 1,000 g post-smolts which took account of capital depreciation costs and operating costs incurred in addition to the “normal” costs for a conventional system. On this basis, the total derived additional costs per post-smolt were between £1.59 and £2.48 per post –smolt. When expressed as a cost per kg of salmon sold, this is equivalent to an additional production cost of £0.37 to £0.57/kg.

Using values for production costs published by one of the main Scottish production companies for 2018, this is the equivalent of an 8% to 13% increase in production costs. The published EBIT by that company for 2018 was £1.75.

Contents

1	Introduction.....	9
1.1	The size of the farmed salmon and marine trout sectors in Scotland	9
1.2	The value of the sector to the economy of Scotland	10
1.3	Strength of the Industry and Future Prospects.....	11
1.4	Targets and Aspirations.....	12
1.5	The Opportunity for Floating Closed Containment Systems.....	14
2	International developments in CCS	16
2.1	Historical perspective	16
2.2	Current status of sea-based CCS development	17
3	Review of CCS designs and technical considerations and options	19
3.1	Preamble.....	19
3.2	Types of CCS structure.....	19
3.3	Floation systems for CCSs.....	23
3.4	Hydraulic design.....	24
4	CCS and sea lice management	28
4.1	Preamble.....	28
4.2	The impact of sea lice on salmon and marine trout production.....	28
4.3	Treatments.....	28
4.4	The cost of treatments.....	31
4.5	Potential of CCS to reduce sea lice infestation	32
4.6	The potential impact of using CCS nurseries on lice costs in Scotland.....	34
5	CCS and waste management	38
5.1	Preamble.....	38
5.2	Details of waste collection systems used in land-based aquaculture systems	38
5.3	Waste collection systems currently in use in floating CCS aquaculture systems	39
5.4	The use or disposal of concentrated fish waste from floating CCSs	41
5.5	Model System for Analysis	43
5.6	Financial Analysis.....	46
6	Potential deployment strategies for floating CCS nurseries in the Scottish industry	51
6.1	Preamble.....	51
6.2	Current stocking and deployment practices	51
6.3	Current deployment regimes in Scotland	54
6.4	Optimisation of current on-growing sites for improved use of MAB.....	58
6.5	The potential use of nurseries to stock on-growing sites	61
7	Financial analysis.....	64
7.1	Preamble.....	64
7.2	Cost analysis.....	64
8	Discussion.....	69
8.1	Logistical benefits	69
8.2	Logistical Challenges	70
8.3	Reduction in sea lice infestation and losses.....	71

8.4	Reduction in solid waste released to the environment	71
8.5	CCS system availability, development and costs.....	72
8.6	Summary of the Financial Model.....	72
8.7	The potential of the Scottish marine aquaculture industry to sustain the increased costs of CCS.....	73
9	Conclusions.....	75
10	References.....	76
11	Abbreviations/Acronyms	87
	Appendix One - SARF SP011 Terms of Reference	89
	Appendix Two - Summary details of existing CCS design and deployment.....	94
	Appendix Three - Summary details of proposed CCS design	129
	Appendix Four – Norwegian “Green” and “Development” Licences	137
	Appendix Five - Sea lice treatment cost calculations.....	138
	Appendix Six - Wastewater Treatment Equipment Descriptions.....	140
	Appendix Seven – The growth model used for all calculations	144
	Appendix Eight - Sites for disposal of CCS solids	149
	Appendix Nine – Depth of selected licensed but un-used sites.....	150
	Appendix Ten - SEPA licences and associated costs relevant to CCS use.....	153
	Appendix Eleven - Capital Cost (Price) Estimates for System Components	155

Tables

Table 1-1 Employment impact of salmon farming in Scotland (from HIE 2017)	10
Table 2-1: CCS systems tested at significant scale	17
Table 2-2: CCS systems at concept or model scale	18
Table 4-1. Frequency and mass of treatments for various pharmaceutical chemical treatments at Scottish sites with >2,499t MAB	35
Table 4-2. Ratio of mechanical treatments and H2O2 treatments to medicinal treatments in Norwegian sites, 2015-16 (from Hjeltnes et al 2017)	35
Table 4-3. Costs of various treatments	35
Table 4-4. Derived costs of lice treatment for various production scenarios based on 4,000 t production from 1,000,000 stocked fish	36
Table 5-1. Descriptions of waste collection and treatment from various commercial CCS.....	40
Table 5-2. Theoretical performance of CCS waste collection and de-watering system components	44
Table 5-3. Solid waste produced from a single 6,000 m ³ CCS unit, per cycle.....	45
Table 5-4. Options considered form land-based waste processing and disposal.....	46
Table 5-5. The total cost of solid waste capture, treatment and disposal for the various system options expressed as £/Post-Smolt produced.	50
Table 6-1. Equipment specifications on Scottish marine sites (from analysis of data from Scotland's Aquaculture website	58
Table 6-2. Cycle dates for 3 consecutive CCS cycles from 100g to 1,000g with 30 days between cycles.....	61
Table 7-1. Energy costs for water supply per CCS nursery cycle	66
Table 7-2. Costs for waste capture, treatment and disposal from the CCS	66
Table 7-3. Total additional operating costs for CCS nursery system (compared with equivalent conventional system and operating methods)	67
Table 8-1. Summary of the financial model.....	72

Figures

Figure 1-1 Marine aquaculture production of Salmon in Scotland by major producers	9
Figure 1-2 Operating costs, market prices and EBIT for salmon production, adjusted to 2017 values (adapted from Marine Harvest 2018). NB, the cost and price data is for Norwegian production; EBIT for Scotland 2013-17 is derived from Scottish data (not shown).....	11
Figure 1-3. Historic and projected Scottish farmed salmon production (showing 2020 and 2030 targets)	12
Figure 3-1. Planned work packages in the SINTEF project "Safe Operation of Closed Aquaculture Cages in Waves"	21
Figure 3-2. The geometries of the flexible containment systems of Akvadesign/Akvafuture (a), Botngaard (b) and Ecomerden (c)	21
Figure 3-3. Akvadesign-proposed CCS with concrete floatation collars (from Kyst 2018).....	24
Figure 3-4. Detail from picture of Aquafarm CCS under construction possibly showing integrated GRP buoyancy ring.....	24
Figure 3-5. The Preline impellor and flow-through system.....	25
Figure 3-6. The Aquafarm supply pump configuration.....	25
Figure 3-7. The articulating inlet on the Ecomerden CCS	25
Figure 3-8. Head loss in 35m long (deep) pump intake pipe for (typical) flow of 0.6m ³ /sec.....	26

Figure 3-9. Outlet structures visible at the base of the vertical wall of the Aquafarm CCS under construction (from http://aquafarm.no/closed-cage/)	26
Figure 4-1. The mass of chemicals used and the number of treatments for treating sea lice in Scottish marine farms, 2002 – 2017.....	29
Figure 4-2. Mass of fish treated for sea lice with chemical methods and annual production in Norway, 2000 – 2015 (from Nodland 2016).....	30
Figure 4-3: Trend in usage of hydrogen peroxide to treat sea lice (Data obtained on request from SEPA).....	30
Figure 4-4. A typical lice skirt arrangement (from FFE 2018).....	32
Figure 4-5. Concept drawing of full-scale “Snorkel cage” (from https://globalsalmoninitiative.org).....	33
Figure 5-1. Solid waste collection and de-watering on floating CCS.....	44
Figure 5-2. Performance values derived for the on-CCS de-watering process.....	45
Figure 5-3. The capital cost of solid waste capture, treatment and disposal for the various system options expressed as £/Post-Smolt produced.....	48
Figure 5-4. The operating cost of solid waste capture, treatment and disposal for the various system options expressed as £/Post-Smolt produced.....	49
Figure 5-5. The regulatory cost of solid waste capture, treatment and disposal for the various system options expressed as £/Post-Smolt produced.....	49
Figure 5-6. The total cost of solid waste capture, treatment and disposal for the various system options expressed as £/Post-Smolt produced.....	50
Figure 6-1. Trend in smolt size at stocking in Scotland (From Iversen et al 2016).....	53
Figure 6-2. Growth curves for fish stocked at 100g at quarter 1 to Quarter 4 predicted from EWOS Growth Model set as described in Appendix 6.....	54
Figure 6-3. The stocking and harvest routine at a large Scottish site, represented by biomass on site (plotted from data on Scotland’s Aquaculture website).	55
Figure 6-4. Biomass on site at selected sites (>2,000t MAB) from one of the major producers.....	55
Figure 6-5. Biomass on site at remaining sites (>2,000t MAB) from one of the major producers showing “out of phase” production	56
Figure 6-6. Production at Scottish marine trout sites excluding Loch Etive	57
Figure 6-7. Marine trout production cycles at sites in Loch Etive.....	57
Figure 6-8. Actual biomass (blue) and Optimised use of a 2,500 MAB site.....	59
Figure 6-9. Comparison between use of conventional production cycle with stocking with 1,000g post-smolts – with 6 month fallow	59
Figure 6-10. Comparison between use of conventional production cycle with stocking with 1,000g post-smolts – with 4 month fallow	60
Figure 6-11. Impact of deployment date at 100g on the number of days required to reach ~1,000g in sea.....	61
Figure 7-1. Maximum flow rates through cycles stocked by Quarters 1 – 4.....	65
Figure 8-1. Total capital and operating costs for CCS for “low cost” and “high cost” case, expressed as cost per post-smolt.....	73

1 Introduction

1.1 The size of the farmed salmon and marine trout sectors in Scotland

The Scottish salmon farming industry produced 189,707t (live weight) in 2017 (Munro and Wallace 2018). At average market prices of £5.82/kg gutted weight and a gutted weight yield of 0.84 (Marine Harvest 2018), this represents a first sale value of £927m. There were 1,362 full-time staff and 69 part-time staff employed directly in all stages of the production of salmon in 2017, many of whom were employed in the highlands and islands of Scotland.

According to the Scottish Salmon Producers' Organisation (SSPO 2018), exports of farmed salmon from Scotland are now worth over £600m per year. Scotland has the third-largest production of farmed salmon behind Norway (1,294,048t in 2017) and Chile (~620,476t in 2017) (Marine Harvest 2018).

In the same year, 3,759t of farmed rainbow trout were produced in sea cages in Scotland (Munro and Wallace 2017) with a first sale value of approximately £19m.

95% of salmon production in Scotland came from 5 companies as shown below.

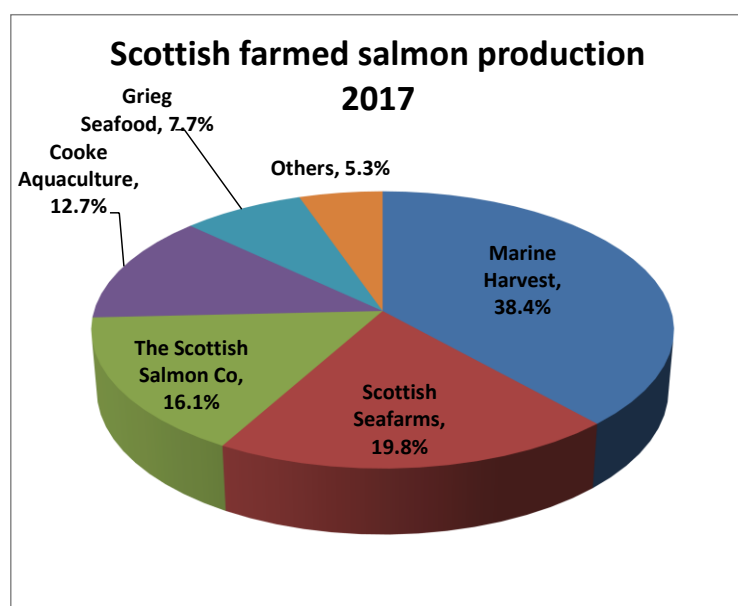

Figure 1-1 Marine aquaculture production of Salmon in Scotland by major producers

Production of trout from marine cages was practised by just two companies, Dawnfresh and Kames Fish Farming. 3,482 t (live weight) was produced by this method in 2017 (Munro and Wallace 2018).

1.2 The value of the sector to the economy of Scotland

In their compiled analysis (HIE 2017) of the economic contribution of the aquaculture sector to the economy of Scotland in 2015, Highlands and Islands Enterprise (HIE) estimated that the salmon farming industry contributed 8,689 full-time equivalent (FTE) jobs from the direct and indirect employment associated with production and a further 1,651 FTEs from “induced employment” (Table 1-1 below):

Table 1-1 Employment impact of salmon farming in Scotland (from HIE 2017)

	Employment (FTEs)	Earnings (£m)
Salmon and smolt production	1,555	46.0
Management and administration	233	8.1
Fish feed supply (incl indirect)	416	10.2
Transport (incl indirect)	534	16.0
Vet services and medications (incl indirect)	596	23.1
Capital investment (incl indirect)	486	14.6
Other purchases by salmon farms	1,530	42.5
Processing - direct	2,854	64.2
Processing - indirect	285	7.1
Transport post-processing (incl indirect)	200	6.0
Total direct plus indirect	8,689	237.8
Induced employment	1,651	33.0
Total employment impact	10,340	270.8

Total Gross Value Added (“GVA”) impact was calculated to be around £540m.

There can be no doubt of the importance of the marine finfish aquaculture sector to the economy of Scotland. Production takes place largely in remote coastal areas of the Highlands and the Northern and Western Isles where the creation and security of jobs is of great value to the maintenance of fragile communities, many of which have experienced long-term economic decline attributable in part to the decline of small-scale fishing and agricultural activity. It is notable that many of the indirect jobs that support the production industry are also located in the highlands and islands – for example, Marine Harvest’s £93m feed plant at Kyleakin will employ 55 people directly in feed production (FFE2017a) and has created 250 jobs during the construction phase (Marine Harvest 2018b) and additional permanent jobs will be created at the associated visitor centre. Similarly, Inverlussa Marine Services on Mull has recently increased its fleet of fish farm workboats by two thereby increasing their fleet to 11 specialised vessels which provide services to major salmon producers including Cooke Aquaculture, Scottish Salmon Company and Grieg Seafoods for contract services such as lice treatments, barge towage, net changing and mooring installation (FFE2017b).

The HIE study (HIE 2017) also provides detailed case studies of many substantial positive social and community impacts of fish farming in rural communities. These include the construction of piers, and marinas with public access at St Margaret’s Hope, the construction of new houses on Muck and the support of 136 charities and community projects with direct financial support (Scottish Sea Farms Heart of the Community Trust).

1.3 Strength of the Industry and Future Prospects

According to Marine Harvest's annual analysis of the salmon industry (Marine Harvest 2018) there is evidence of a continuing strong underlying demand for farmed salmon. Considering world production, the value of salmon in real terms has increased 4.4 times between 2004 and 2017, whereas the production volume has only increased by 91%.

Scottish salmon normally commands a premium compared to Norwegian salmon, though the pricing of Scottish salmon (and Faroese, the next largest supplier to Europe) is tied fairly closely to the Norwegian price.

The national average production costs for farmed salmon and trout tend to be fairly stable though there can be significant site-to-site variations, largely attributable to differences in treatment costs, losses through disease and feed management efficiency. Over the long term, the impact of consolidation of companies and the associated economies of scale, combined with equipment and operational optimisation resulted in a relative reduction in average costs over the main period of world-wide industry growth from 1993 – 2004. Since then however, there has been a steady increase in relative operating costs, attributable to rising feed costs, disease treatment costs and more stringent regulatory compliance procedures (Marine Harvest 2018).

On the other hand, market prices show substantially greater year-on-year fluctuations, reflecting mainly the effect of fluctuating supply and demand but also being influenced by world economic factors such as currency values.

Nevertheless, the production of farmed salmon remains a profitable activity; in their review of group performance, Marine Harvest (Marine Harvest 2018) provides details of profitability expressed as operational earnings before interest and tax ("EBIT"), adjusted through a consumer price index to 2017 figures. This data is reproduced in Figure 1-2 below.

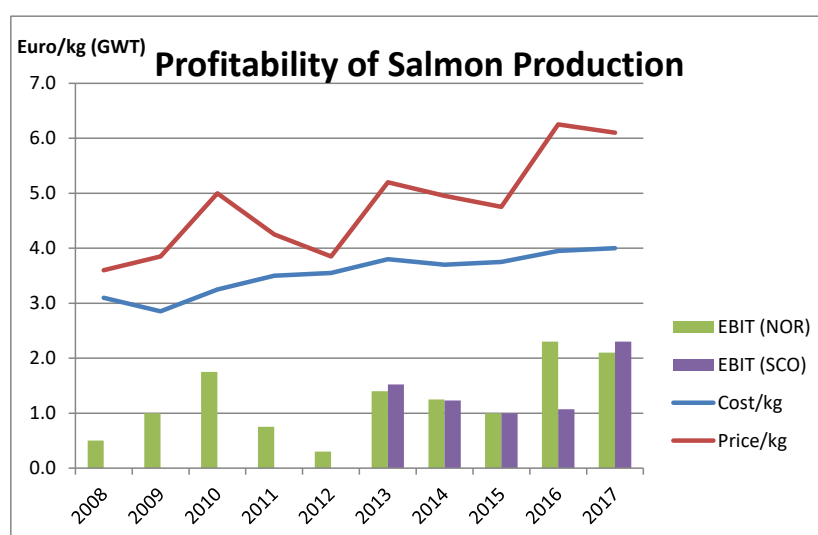

Figure 1-2 Operating costs, market prices and EBIT for salmon production, adjusted to 2017 values (adapted from Marine Harvest 2018). NB, the cost and price data is for Norwegian production; EBIT for Scotland 2013-17 is derived from Scottish data (not shown).

1.4 Targets and Aspirations

It is not surprising that the continuing world-wide growth in demand for farmed salmon and trout and the substantial economic benefits which the industry brings to Scotland, lead both the industry and the Scottish Government to welcome continued expansion of the activity in Scotland. Specifically, the Scottish Government supports the Scottish aquaculture industry's target of an increase in production of marine finfish by 2020 to a total of 210,000t. It also supports the Aquaculture Industry Leadership Group as it seeks to deliver the industry's growth strategy by 2030 (AILG 2016) which sets the aspiration for Scottish production in 2030 to reach "300,000 to 400,000 tonnes per annum". It notes that "To reach this tonnage (of farmed salmon) from current levels would require year-on-year growth of less than 5%".

These targets are shown in Figure 1-3 below which also shows a projection of production to 2020 and 2030 at the current rate of growth.

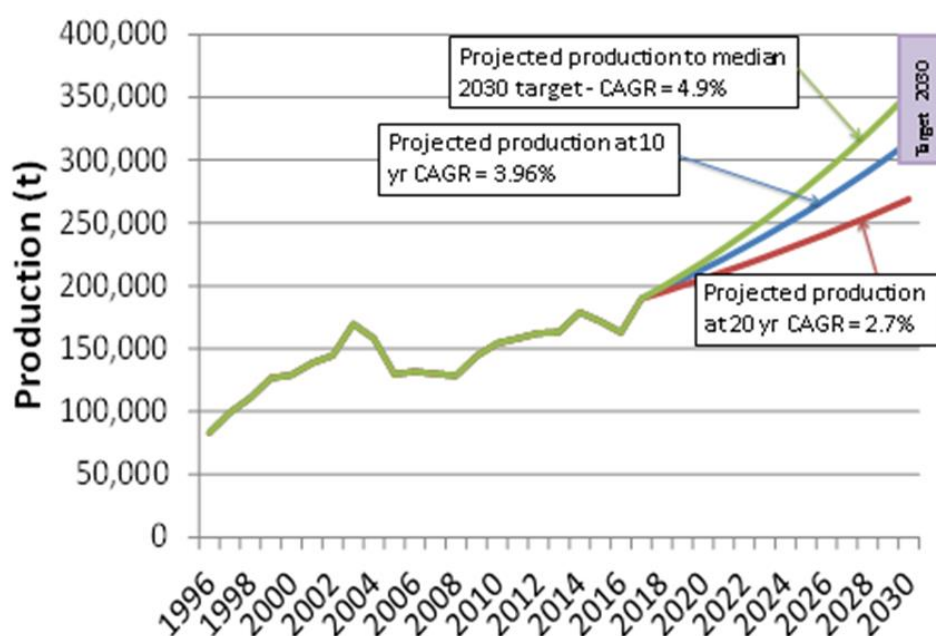

Figure 1-3. Historic and projected Scottish farmed salmon production (showing 2020 and 2030 targets)

Using the compound annual growth rate over the last 10 years of 3.96%, the projected production in 2020 is 213,172t and 302,461t for 2030. However, 2017 saw a sudden "spike" of 16.5% which has substantially increased the CAGR. The industry's own prediction for production in 2018 is actually for a reduction by 20% (Munro and Wallace 2018). Using the more conservative 20 yr CAGR (2.7%) the projected production by 2030 is 269,000t – substantially below the industry target. To achieve the median 2030 production target of 350,000t will require an increase in annual growth to 4.9% - an increase of 23% over the current 10 yr rate. Clearly, a change in approach to increasing production is necessary if targets are to be achieved.

A fundamental requirement for an increase in production is either more sites or more production from existing sites, or both. As noted by Jeffery et al (2015), the rate at which new sites are licensed is slow and the present maximum biomass which is permitted by SEPA on the largest sites is 2,500 t. Whilst there is a perception that access to sites for production is the major restriction to development of the

industry as explored by Jeffery et al (2015), this rather over-simplifies the challenge to production companies. Whilst it is undoubtedly true that securing any new site is a long and complex procedure for which the outcome is never guaranteed, it is becoming increasingly the case that production companies are quite selective about the areas in which they will consider beginning the process for a number of reasons (Alex Adrian, Crown Estates Scotland, pers comm).

In the first place, the challenges of biosecurity and management of sea lice are such that despite the current requirements for collaboration between companies in adjacent sites through Management Area Agreements (see section 4), it is clearly desirable to operate in sites where there is limited, or no potential for biological and environmental interaction with sites operated by other companies. Second, there are areas in which there are active sites with the potential for further expansion, but where experience has shown that conflict with other parties – for example in busy tourist areas – mean that there are likely to be many objections to new applications, making the process long, expensive and unpredictable. Third, production companies will prefer to invest in sites with the potential for efficient use of transport of smolts, feed, equipment and personnel being key considerations, as well as the potential for future expansion in adjacent areas. The strategic choice of potential sites has therefore moved on from targeting, for example, a particular sheltered bay to the identification of a large area containing a number of possible cage locations, allowing progressive expansion, optimal use of inputs and resources and maximum biosecurity.

The other major constraint to the achievements of growth targets is the negative perception of the environmental impact of marine cage aquaculture. Concerns particularly focus upon two areas: first, the role of marine cage aquaculture in the propagation of sea lice and the potential impact on wild salmonid populations and second, the impact on the environment of the solid and soluble fractions from waste feed and faeces released from cages.

These concerns have been prominent as the objects of an Inquiry by the Scottish Parliament through the Rural Economy and Connectivity Committee (“RECC”) into Scottish salmon farming which resulted in part from the submission of a formal Petition to the Parliament by the organisation Salmon and Trout Conservation Scotland. The Inquiry began with an investigation by the Climate Change and Land Reform Committee (ECCLR) into environmental impacts. Their activities included the commissioning of a report from the Scottish Association for Marine Science (“SAMS”) (SAMS 2018) and the hearing of evidence from many interested parties. The ECCLR’s concluding report (ECCLR 2018) main conclusions (brackets added for context) included:

- *“There has been a lack of progress in addressing the environmental impacts of salmon farming since they were last highlighted (at the Scottish Parliament) in 2002.”*
- *“The Committee is deeply concerned that the development and growth of the sector is taking place without a full understanding of the environmental impacts.”*
- *“There need to be changes to current farming practices. The industry needs to demonstrate it can effectively manage and mitigate its impacts.”*
- *“The Committee is supportive of aquaculture, but further development and expansion must be on the basis of the precautionary approach and must be based on resolving the environmental problems. **The status quo is not an option.**”*

The final report of the RECC (RECC 2018) was published in November 2018. It includes 65 recommendations to improve the industry including actions specifically aimed at reducing the potential impact of sea lice on wild salmon and on reducing the impact of fish farm wastes as effluent on the environment. Specifically, these include:

(Recommendation 45): “... the siting of farms in the vicinity of known migratory routes for wild salmon must be avoided”;

(Recommendation 54): “The Committee recommends that work to examine the scope for siting salmon farms in suitable offshore and other locations where there are higher energy water flows should also be treated as a high priority by the industry. It acknowledges that there are significant technological challenges associated with locating farms in these areas, as well as risks in terms of workforce health and safety. However, it also notes the benefits this could bring in terms of addressing fish health issues, reducing the environmental impact of waste and providing scope for the industry to develop higher capacity sites.” ;

(Recommendation 56): “... urgent research on the subject (of closed containment technology) and consideration of ways to incentivise the industry to explore further use of the technology”.

The report also noted that “as the salmon industry in Scotland has evolved in recent decades, farms may have been located in areas which are now recognised as being environmentally sensitive (such as MPAs or PMFs) or are less well-suited to production for a variety of reasons. It welcomes the fact that some operators are already actively looking to relocate poorly sited farms or to consolidate farms in less sensitive areas”, and recommended:

(Recommendation 53): “...the Committee considers that there should be immediate dialogue with the industry to identify scope for moving existing poorly sited farms. It recommends that this should be led by Marine Scotland and encouraged with appropriate incentives for operators, such as giving favourable consideration towards allowing increased capacity at replacement sites that are known not to be environmentally sensitive. ”

Implementation of these recommendations will undoubtedly further reduce the short-term rate of expansion of the marine aquaculture production sector in Scotland.

1.5 The Opportunity for Floating Closed Containment Systems

Floating closed containment systems (“CCS”) as nurseries have been proposed as a means of addressing some of the issues which are constraining growth in Scottish marine aquaculture. The potential benefits include:

- Improved optimisation of biomass limits (thereby increasing production) from existing on-growing sites;
- Shortening the time spent in conventional open-pen systems, thereby reducing the potential exposure to sea lice; and
- The collection, treatment and disposal of a considerable portion of the solid waste feed and faeces from the production process.

The purpose of this study is to investigate the technical and economic feasibility of the incorporation of a closed containment sea pen system nursery phase within the overall production cycle for Atlantic salmon and marine-grown rainbow trout in Scotland.

In section 2 we have reviewed the current status of CCSs throughout the world (we are not aware of any use in Scotland at present) and in section 3 we have identified the essential design requirements of a CCS and considered ways in which these are met by various systems in use or under

development. In order to assist that analysis we have drawn upon the findings of some outline design exercises for various types of CCS which have been carried out by the commercial partners to Stirling Aquaculture, aligned for the purpose of this study, all of whom are commercial suppliers to the Scottish industry.

In section 4 we have considered the potential of the adoption of a production strategy based upon use of a floating CCS nursery to reduce infestation by sea lice throughout the whole growing cycle and we have proposed a financial model which provides a method to calculate the potential financial savings in treatment costs and mortalities achieved with this strategy, compared with a conventional grow out cycle in open pens.

In section 5 we have reviewed the status of waste collection and treatment from cages and proposed a simple process of waste collection and de-watering on the floating structure and considered various options for disposing of the concentrated waste. A methodology has been developed for cost analysis and a range of costs have been derived based on different processing scenarios.

In section 6 we have considered how CCS nurseries could be used to increase the output from existing on-growing sites by improving the efficiency of use of the maximum allowable biomass limit of those sites. Of course, this assumes that suitable sites can be found for floating nursery systems and we note that some licensed but currently unused sites may have potential for this application.

In section 7 we have conducted a financial comparison of the use of floating CCS nurseries in Scotland with conventional production methods. We have used a financial model which considers the additional costs of installing and operating CCS nurseries compared with conventional systems, including the costs of collecting and processing waste.

In section 8, we use the previously-established technical and financial analyses to consider the broader aspects of the potential use of CCS nurseries in Scotland and derive some cost-benefit values.

As much of the technical and financial analysis in this document is speculative, being based upon theoretical assumptions of projected costs and performance, we have, wherever possible and appropriate, stated the assumptions made and provided details of the calculations used in the modelling process so that these may be modified or challenged by others as new information emerges or technical developments are made.

2 International developments in CCS

2.1 Historical perspective

The potential for enclosed floating aquaculture systems has been pursued for over 25 years with designs emerging from the early 1990s onwards. Anon (1991) and Skaar. & Bodvin (1993) report on a Norwegian system trailed in the early 1990s. This was developed by Oppdrett Service A/S in conjunction with SINTEF and utilised a 450m³ PVC bag. Early problems with the design included serious deformation due to currents and a “sloshing” movement of the water which developed as the cage moved up and down in the waves (Solaas et al 1993).

Further development of the concept was through a Canadian company – Future SEA Farms. They utilised bags of 1,450 m³ (15m diameter and 10m depth). The bags were made of PVC coated onto a woven polyester fabric and initially suspended in a conventional cage collar. Subsequent designs involved a reinforced stand-alone structure to cope with the high loading forces from currents and waves (Future SEA Farms, 1997). This system had a pumped inlet with a positive head maintained inside the enclosure in relation to external sea level. This pressure reduced problems with bag deformation although issues were still encountered with differences in seawater salinity and hence density affecting the system. The pump system operated with a total head of around 0.5m at 90% efficiency.

The first large-scale floating rigid systems were also developed in Canada. Mariculture Systems Inc., developed the SARGO closed containment fish rearing facility. This GRP system was designed to produce 500 tonnes from the stocking of 200,000 smolts and was installed at a site near Campbell River in BC in 2003 following initial success with a pilot unit in Washington State. The system employed a pumped water supply without aeration or other treatment but had a double drain system to allow solids capture and on-site settling and storage (DFO, 2008). Another company, AgriMarine Inc, was selected by the government of British Columbia to study the potential for solid-walled, land-based containment systems but concluded from the results of trials at Ceder on Vancouver Island that land-based farming was not financially viable at the scale needed to rear large salmon (Agrimarine 2009). Instead, they turned their attention to the development of a floating concrete system which was also deployed in the Campbell River area of British Columbia. These were up to 5,500 m³ in volume (Agrimarine 2004). In 2009, they secured funding from a Chinese investor to switch their technology to floating GRP tanks (Agrimarine 2009b) and these became the forerunners for the Agrimarine system used for production to this day. Their design also employed both a waste trap and macro screen for removal of larger waste particles, followed by a series of smaller screens (including a fine mesh rotating belt screen) for fine solids removal and dewatering of the waste (Grant et al, 2009).

A range of structural and operational problems were encountered with early designs, as might be expected of prototypes. The main constraint to adoption however has probably been financial. A Canadian Department of Fisheries and Oceans report in 2008 (DFO, 2008) reviewed available closed containment technologies, including on-land recirculated aquaculture systems and concluded that the costs were uncompetitive compared with open sea cage-based farming.

More recently CCS received a major boost with the establishment of the CtrlAQUA project in Norway. This NOK 200 million, 8-year project which started in 2015 brings together four Norwegian research institutions, two others from outside Norway and several industry partners to create a centre for innovation in closed-containment systems (CtrlAQUA 2015). The primary focus is for “Nursery” systems to produce salmon post-smolts up to one kilogram.

2.2 Current status of sea-based CCS development

We have identified at least ten CCS which have been built and tested in recent years and a further four which are at least advanced designs and are in the production and testing pipeline. The emphasis especially in Norway is now towards their use for post-smolts (up to 1 kg) although their use for full grow-out is considered possible and tested in some cases. As a result of the CtrIAQUA project, Norway is now the centre of development, although some activity continues in Canada where there is considerable opposition to open pen farming. The systems are summarised in the following tables with fuller details available in Appendix two and three. Design features are discussed in more detail in the following section.

Table 2-1: CCS systems tested at significant scale

System	Construction	Volume	Status	Notes
AgriMarine (Canada)	Sectional GRP reinforced with steel	3,000-5,500m ³	Trialled in Canada (2009-Pacific Salmon, 2011-trout, 2012-Chinook Salmon) and China (2009-trout).	A winter storm damaged a system, resulting in escapes in Canada, 2012. Systems are outfitted with a proprietary solids capture and concentration system
AkvaDesign (Norway)	concrete collar with hemi-spherical polyester "skirt"	6,000 m ³	Trialled in Brønnøysund, Norway, 2015-present	Designed for wave heights up to 2m. Facilities for sludge removal
AquaDome (Norway)	Composite rigid hemisphere	5,560m ³	First pilot (2014) destroyed in hurricane. Redesign underway, but future of project uncertain.	27 m diameter
Aquafarm Neptun 3 (Norway)	Lightweight GRP with high tensile steel reinforcement	21,000 m ³	Trialled at Molnes, Norway. First system damaged by storm in 2014. Second system restocked in 2016.	Designed for wave heights up to 1.8m and currents to 0.75 m/sec
Botngaard System (Norway)	Fabric system for retrofit on existing cage	2,500 - 8,000 m ³	Successful trials and commercially available	Water turnover time 40 minutes, also uses oxygen injection
Ecomerden Ecocage (Norway)	Double-walled flexible membrane, superstructure and floatation in steel	6,000 m ³ & 12,000 m ³	Trialled in Norway from 100g to market size, 2015 – 2017 commercially available	Water intake with UV treatment and oxygenation. Particle filter and sludge pump for waste.

System	Construction	Volume	Status	Notes
Fishglobe (Norway)	PE globe with reinforced superstructure	3,500 m ³ for postsmolts and 29,000 m ³ for growout	Smaller versions tested in Norway	Technology to completely control internal environment
Lerøy Preline (Norway)	Plastic and steel superstructure supporting horizontal, PE, oval-section tube raceways	2,000 m ³ (pilot) – provision for multiple tubes on commercial system	Trialled in Norway (6 batches of smolts by end of 2017)	Water pumped from 30m and replaced every 6 minutes
Salmon Home No 1 (Norway)	Floating lightweight reinforced concrete tank	Trial unit 1,000 m ³ large 5,000 m ³ unit planned	Pilot system tested since 2016	
Aquatraz (Norway)	A net pen which is semi-enclosed within a steel wall which can be raised and lowered		Pilot system deployed	Only a semi-enclosed system, but combats sea lice and other surface layer planktonic threats

Note: The systems in bold text are reviewed in the following section.

Table 2-2: CCS systems at concept or model scale

System	Construction	Volume	Status	Notes
Egg (Norway)	Composite sandwich formed in a complete seamless double curved surface		Site licence granted	44 m deep and 33 m wide
Salmon Zero (Norway)	Concrete		Concept only	RAS with landbased treatment for floating tanks
FlexiFarm (Norway)	Conical flexible membrane		Not yet tested	Inlet water UV treated; possibility to collect sludge
Hydra Pioneer/Hydra salmon (Norway)	Open steel tank with floatation and mesh grid at bottom	56,000 m ³	40 th scale model tested	Site approval obtained in April 2018

A key factor is that the CtrlAQUA project is providing much higher quality analysis to the performance and operational issues involved with CCS. This includes better monitoring of water quality, health and welfare indicators and further investigation of factors such as lighting and water velocities on fish behaviour and performance. Results to date show that CCS can improve salmon welfare and overall condition (SFI, 2018). This information is feeding back into further refinement of designs and operational management. Progress is also being driven in Norway through the issuing of development licences – where access to sites is conditional on the use of innovative technology that addresses issues of environmental impact and the sharing of developed technology to generate industry wide improvements (Ernst & Young, 2018). Norwegian development licences are considered further in Appendix four.

3 Review of CCS designs and technical considerations and options

3.1 Preamble

This section reviews design principles and options based on the eight systems that are most advanced in terms of development and deployment, as noted in Table 2.1 via the system name in bold text. Consideration of existing approaches enables the identification of critical design features. We have also worked with a group of Scottish commercial aquaculture equipment supply companies jointly to consider some of the issues in more depth and to construct outline design concepts which we have used to carry out an analysis of potential CCS capital and operating costs (reported in later sections).

3.2 Types of CCS structure

Of the eight main systems under consideration, one – Preline – stands out as unique in design and operation. The other seven are broadly similar in their design concept and geometry – being circular or hexagonal in plan, but represent three different points in the continuum of material choices for the containment structure.

3.2.1 Concrete systems

Salmon Home No 1 (SHN1), manufactured from concrete, represents one end of the continuum. The containment system will not deform under current load, the considerable mass of the structure will result in an inertia to wave motion and the structure can be made sufficiently strong to resist impact damage or fracture due to excessive loading from current and wave action. However, the general trend in marine aquaculture has been to use increasingly large culture units and the technology and equipment handling and transport systems required to produce a commercial-scale system would exceed the capabilities used for the largest aquaculture barges and become the domain of oil rig fabrication yards and facilities. The advanced prototype of SHN1 is one of the smallest of the systems under development at 1,000m³, though the companies have stated that at full-scale they will produce 5,000m³ units. According to Roaldseth et al (2016) the 1,000 m³ structure weights 250 tonnes and this indicates one of the characteristics of using a heavy concrete structure in that providing enough floatation to support the structure when full is challenging and can only easily be achieved by building floatation chambers within the walls of the structure itself. Whilst this clearly adds to the complexity of the structure itself, it also offers extremely secure potential for the housing of the associated plant and machinery necessary for operation of the CCS.

One of the commercial partners (Gael Force) in this project has conducted an outline design exercise for a 6,000m³ concrete system. They concluded that a commercial product could be sold for around £6m including all plant and equipment. However, they also noted that the development costs would be substantial, suggesting the engineering design and development exercise could be £1 - £2m and construction of a full-sized prototype would typically cost 2 x the routine manufacturing cost – ie, around £12m.

A second commercial partner in the project (Concrete Marine Solutions, "CMS") proposed a rather different, novel design using a light-weight concrete solution comprising two concentric reinforced concrete walls (using "lytag" lightweight concrete), connected by 12 vertical concrete spacers and transverse galvanised steel pipes. They estimated a cost of construction of the concrete elements alone (ie, no plant) at £850k, though additional costs of £750k for a construction and delivery pontoon and formwork and a dedicated workboat (for the construction) at £650k were noted as essential requirements.

The mass of the Gael Force model 6,000m³ structure (empty) would be >2,000t implying a need for substantially heavier mooring grids and anchor systems with associated higher costs associated with concrete CCSs when compared with conventional open sea pens. A more complete consideration of potential system costs is presented later in section 7.

The mass of the CMS system was estimated at 750t.

The Gael Force analysis noted that modelling the mooring requirements of a concrete CCS of this scale was beyond the parameters of the load modelling software that is used in compliance with the Scottish Technical Standard. However, using the current (static) model the design load on the structure was calculated at 65t – which compared with a conventional net pen was 23 times greater than would normally be expected if an open pen were to be moored independently (which is unlikely). Whilst it is unreasonable to infer too much from this, given the CCS analysis was outside the range of the model, it nevertheless implies a likely order of magnitude difference between the mooring requirements (and potentially the mooring costs) of a concrete CCS and an open pen.

There is no doubt that concrete offers a robust solution for CCSs that could be operated in more extreme current, wind and wave conditions than systems based on other flexible materials. However, further engineering design and analysis is required before reliable conclusions regarding the financial viability can be established.

3.2.2 Fabric systems

At the other end of the material spectrum, flexible membranes are used as the containment structure in three of the systems under development (Ecomerden, Botngaard and Akvadesign/Akvafuture). Fabric structures are likely to offer the least expensive options for CCS and designs based upon fabric containment systems have proved an attractive choice for some of the early experimental programmes. An early multi-partner European project (EU 2009) "CLOSEDFISHCAGE" which was funded under the Seventh Framework Programme investigated the behaviour of a flexible containment system and eventually constructed and tested both the physical performance and the suitability for fish culture of a pilot device of 12m diameter. The project led to an enhanced scientific understanding of the biological, physical, operational and regulatory requirements for sea-based fish farming using the prototype cage. Trials were carried out in a moderately exposed place (according to NS 9415) with a wave height of max. 1 meter and current speed of max. 1 m/sec (Rasmussen and Løvstad 2013).

Although the work in CLOSED FISHCAGE (EU 2009) and subsequent multi-partner projects (for example, CtrlAQUA) included attempts at constructing theoretical models for the performance of flexible containment structures under various loading conditions, these have not resulted in readily-available guidelines for the construction and deployment of equipment. Analyses such as that of Strand et al (2013) have contributed greatly to the development of theoretical methods for analysis of

the forces acting on flexible bag structures under varying loads, operating conditions and mooring systems but have also served to demonstrate the complexity of a theoretical modelling approach.

A new, multiparty project¹ "CCW" – the Safe Operation of Closed Aquaculture Cages in Waves – has recently begun at SINTEF based on the stated premise that, "There are few examples of floating structures with features similar to closed aquaculture cages.... there are no numerical models that can adequately predict response in waves". In particular the project will look at the combined response of closed containment structures to the external forces of currents and waves and the interaction with the water (and fish) within the system as separate work packages as shown below.

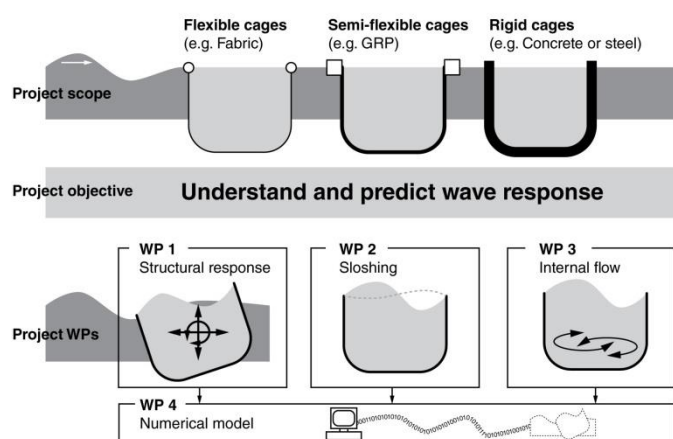

Figure 3-1. Planned work packages in the SINTEF project "Safe Operation of Closed Aquaculture Cages in Waves"

In practice, all systems seem to have been largely developed using an empirical approach based upon practical model testing and prototype trials.

The main disadvantages of flexible closed cages are their susceptibility to deformation under load – with consequences for the fish within – and the risk of mechanical failure under load. The first of these concerns has been addressed in a practical sense by the three example systems in that geometries of containment system have been used which will offer a reasonable containment volume whilst offering a reduced profile to horizontal currents – ie, inverted hemispherical or conical shapes (fig 3.2).

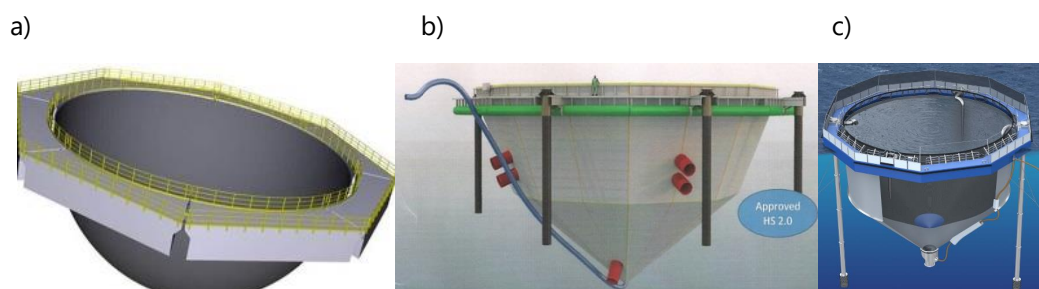

Figure 3-2. The geometries of the flexible containment systems of Akvadesign/Akvafuture (a), Botngaard (b) and Ecomerden (c)

¹ Project description at <https://www.sintef.no/en/projects/safe-operation-of-closed-aquaculture-cages-in-waves-ccw/>

The second main area of concern about flexible structures is the potential for the membrane material to split or tear. Unlike a net in a conventional open pen, a small split or tear in a fabric membrane could propagate quickly with catastrophic consequences. The Ecomerden Ecocage appears to mitigate this risk by having a double-walled structure, with the inner containment system being a net structure and the Akvadesign system is described as having a “Double-layer of safety net” (UCS 2017b). This will add to the cost, both in terms of capital equipment and in operating costs (cleaning and changing nets) so there is a trade-off between cost and risk of mechanical failure.

All three flexible cage structures are certified according to Norwegian Standard NS9415 (2009) with Botngaard quoting a certified significant wave height (“HS”) of 2m for their “Post Smolt 8000” system and HS of 1.5m for their retrofit system for existing circular plastic cages or square steel structures.

An advantage of a flexible containment system is its initial cost. One of the commercial partners in the present study (W & J Knox Ltd) worked with their main material supplier to produce a design concept for a 6,000m³ bag of similar geometry and material specification (2,400g/m² PVC-coated weave) to the Botngaard system. They estimated that this could be manufactured and sold at a price of approximately £145,000. However, as shown in the financial analysis in section 7, if the system capital cost is expressed as a cost per kg of fish produced, by considering annual depreciation charges, the picture is less straightforward; whilst considerably less expensive than a concrete or GRP system, the stronger option for the Botngaard flexible fabric material (2,250g/m²) is stated by them to have a working life of only 5 years (the thinner material is quoted as having a 2 year working life). By contrast, the Aquafarm rigid GRP system (see below) has a working life (according to the supplier’s website) of 25 years.

The price for a complete 8,000m³ Botngaard system was estimated verbally by the company (Roy Clarke, pers comm) as 12m NOK or ~£1.12m. Reduced *pro rata* to a 6,000 m³ capacity for comparison with other system types, this equates to a system purchase price of £837,000.

3.2.3 Lightweight rigid containment systems

The remaining two CCSs in practical use are the Agrimarine system and the Aquafarm Neptun. These have the common origin of Agrimarine’s development programme which was licensed to Akvatech AS (private equity group in Norway) in 2012 (Agrimarine 2012).

The history of the development of Agrimarine’s CCS is presented in section 2. On several occasions their systems have reportedly suffered break-ups through storm damage (Agrimarine 2012a). After several generations of designs the current systems are in regular use (Agrimarine) and under advanced trials by Marine Harvest (Aquafarm Neptun) (Fish Farming Expert 2017).

The structure is built up from modules formed in GRP and reinforced with steel structures. It offers advantages over flexible systems in that it is not susceptible to excessive deformation under load and may be more resistant to physical damage. As a lightweight solid structure, it has advantages over the concrete system in that it requires less buoyancy to maintain its position. On the other hand though, it has less inertia than the concrete system so will tend to respond more directly to wave action.

The design is reportedly certified to NS9415 (2009) with operating conditions of:

- Significant wave height $H_s = 1.0\text{m}$
- Max wave height = 1.8m

- Design wind velocity = 30 m/s
- Current velocity = 0.75 m/s
- (<http://aquafarm.no/closed-cage/>)

The cost of the GRP system appears to sit close to, but slightly more expensive than a fabric system, though its working life is claimed to be considerably longer. According to Aquafarm's website (<http://aquafarm.no/economy/>) the cost of a complete system is between 2,000 and 2,400 NOK per m³ capacity, the equivalent of £1.227m for a 6,000m³ system, and its working life is stated as 25 years.

3.3 Floatation systems for CCSs

As mentioned in section 3.2.1 above, proposed concrete designs have generally included internal buoyancy chambers. For the lighter-weight GRP and flexible systems though, the provision of buoyancy is an important consideration. Unlike an open pen system, the mass of culture water is retained in the culture system, so in the event that some or all of the surface of the culture water is above the surrounding ocean surface level – for example, as a result of the CCS pitching or rolling, the mass of the raised volume needs to be adequately supported by the inherent buoyancy in order to prevent the CCS from “heeling”.

Furthermore, a flexible containment structure with a permanent pumped inflow of water will need to have a permanent positive hydrostatic head in order that the system geometry is maintained (*ie* the containment bag is “fully inflated”) and to maintain the flow balance through the system. According to Botngaard (Pers comm to Roy Clarke) their system should run at “a few cm” positive hydrostatic head. However, for each 1 cm of positive head there would be an additional system mass of 5t so a CCS requires considerably more reserve buoyancy than the equivalent-sized open pen.

The largest HDPE tubes which are used for conventional open pens have an inner diameter of 400mm. According to a commercial partner in the present study (Gael Force) a triple-ring 80m circular pen has a net buoyancy potential of about 18t. Botngaard use a ring of 1,000mm ID which would result in approximately 40t net buoyancy. However, a tube of this diameter would be difficult to engineer for any tighter curve than the circumference of Botngaard's 8,000m system so it may be difficult to use tube systems for smaller (80m) circular CCSs.

The Ecomerden CCS uses rectangular-section metal floats for buoyancy, originally made from steel but now also offered in aluminium. Whilst such a system is relatively easy to design and construct, the fact that it is made from straight elements means that the Ecomerden CCS is octagonal, rather than circular and the relative rigidity of the collar compared with the Botngaard pipe system will result in greater displacement with wave action, potentially resulting in greater loadings on fittings between float units and between the net and bag systems and the deck.

According to Kyst (2018), Akvadesign/Akvafuture will use its development licences to install a raft of flexible CCSs with individual concrete floatation collars (figure 3.3 below):

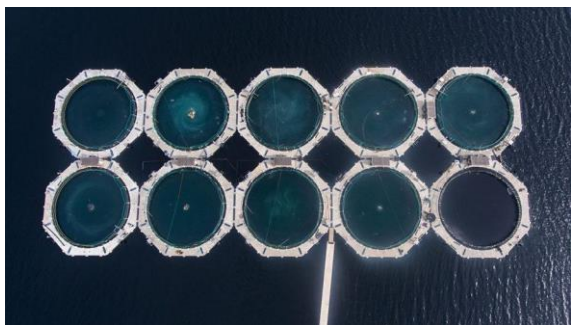

Figure 3-3. Akvadesign-proposed CCS with concrete floatation collars (from Kyst 2018)

We cannot find details of the floatation system for the Agrimarine and Aquafarm CCSs though the latest model of the Aquafarm appears to have an integrated buoyancy collar in the GRP structure (see details in fig 3.4 below).



Figure 3-4. Detail from picture of Aquafarm CCS under construction possibly showing integrated GRP buoyancy ring

3.4 Hydraulic design

After consideration of structural geometry and materials the next major issue is ensuring an adequate water exchange to replenish dissolved oxygen, remove dissolved and solid wastes and provide a suitable flow regime and current velocities for the fish.

3.4.1 Water supply systems for CCSs

The principles of water supply are broadly similar for all of the CCSs considered here. All designs are based upon supplying all of the oxygen requirements of the fish in the system from pumped water exchange, though in most cases it is stated that oxygen injection into the incoming flow is also possible.

An important and potentially advantageous feature of floating CCSs is that the energy for pumping water to supply oxygen for fish respiration is considerably less than that required for pump-ashore systems or even for RAS. This is because the hydrostatic head through which the water needs to be pumped is negligible; it can be pumped from the deep intake to the surface with only friction head losses plus a hydrostatic head of, say, the average height of the inflow jet above the surface (assuming water is injected above the surface) – which may be a few cm. The friction head losses in the system can be minimised by the use of large diameter piping.

The most extreme example of this in the systems under consideration is the Preline system which is essentially using a large impellor to move water longitudinally through the CCS "raceways" beneath the free water surface (Figure 3-5). Similarly, the inflow jets in the Ecomerden system and the pump inlets to the Aquafarm system are shown (in graphics) to enter the CCS beneath the free water surface (Figure 3-6 and Figure 3-7, below).

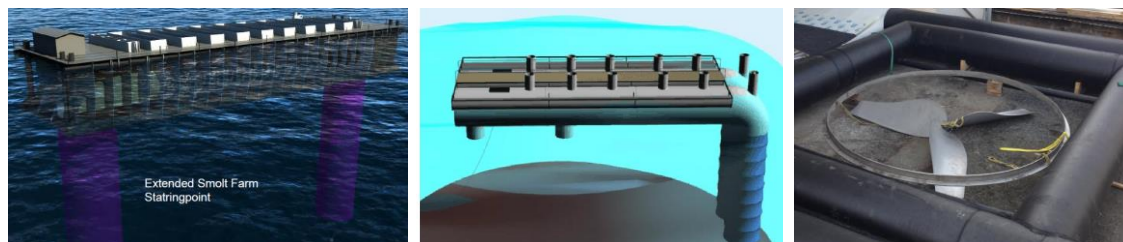

Figure 3-5. The Preline impellor and flow-through system

In all cases, the water intake is through pipes extending to > 20m beneath the surface to avoid sea lice. No system reportedly uses filtration at the intake, other than coarse screening to exclude fish and larger objects. In the case of Salmon Home No 1, the pumps appear to be integrated into voids in the concrete wall structure, as was the case for the concept design exercise produced by Gael Force as project partners to the present study.

The other CCSs under consideration have pumps mounted on the decks or walkways of the floating systems, or (in the case of Aquafarm) on external "satellite" pump stations branching out from the main structure (Figure 3-6).



Figure 3-6. The Aquafarm supply pump configuration

The Ecomerden CCS injects the inflow water throughout much of the depth of the contained system by means of a tapering nozzle with an array of horizontal jets. This can be articulated to raise it above the inner net for net changing (Figure 3-7)



Figure 3-7. The articulating inlet on the Ecomerden CCS

All CCSs under development use large-diameter intake pipes with screened openings at 20-30m below the surface. Typically designs include 4 or 6 pumps, each with its own deep supply pipe. The large diameter is crucial to minimise friction head losses and hence energy requirements. The impact of pipe diameter is shown in Figure 3.8 below,

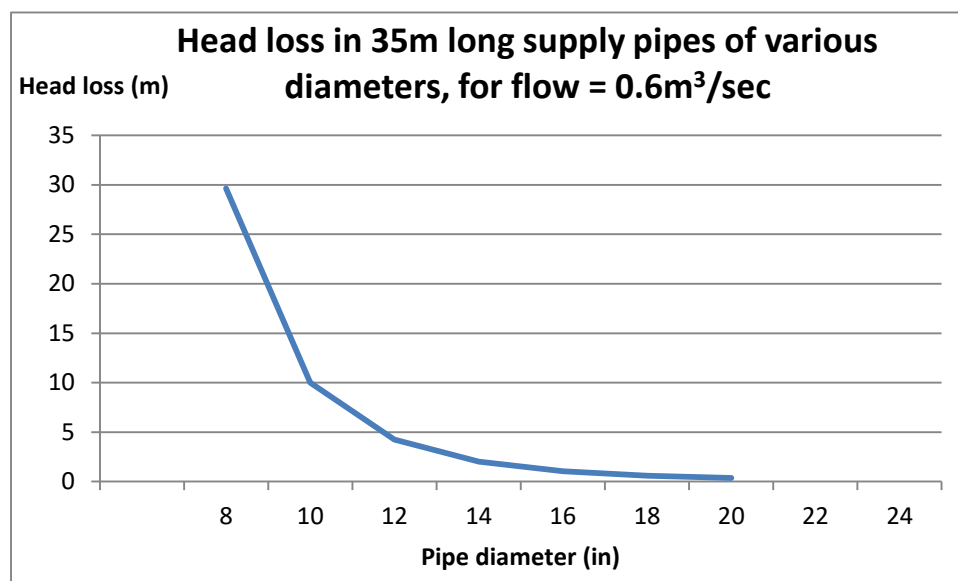

Figure 3-8. Head loss in 35m long (deep) pump intake pipe for (typical) flow of 0.6m³/sec

The importance of using large diameter pipes for the water supply is crucial to minimising energy requirements. Decreasing the pipe diameter from 24" (600mm) to 18" (450mm) increases the head loss (and associated energy cost) 4-fold from 0.15m to 0.59m².

3.4.2 Water outlet system

The water outlet system plays a crucial role in the flow regime within the CCS. The Agrimarine and Aquafarm systems make use of remotely-driven outlet covers positioned around the periphery of the base of the system. They can be seen in the photograph of the Aquafarm CCS under construction in Figure 3.9.

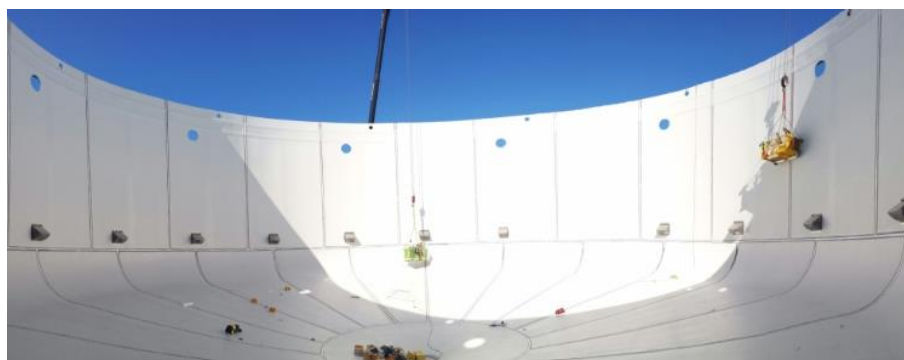

Figure 3-9. Outlet structures visible at the base of the vertical wall of the Aquafarm CCS under construction (from <http://aquafarm.no/closed-cage/>)

² For a flow rate per pump of 2,179 m³/hr

3.4.3 Flow regimes in floating CCS nurseries

In open pen systems, flow regimes and overall water exchange are dictated by tidal currents and other wind- and wave-generated water movements through the net panels. In CCSs the flow regime is determined by the mass flow of pumped water supply, the system geometry and the positioning of inlet and outlet structures.

We have found no specific studies of the flow behaviour within floating CCSs which offer definitive hydraulic principles which can be applied to future CCS design. However, as large vessels, CCSs are to some extent analogous of large tanks used in pump-ashore and RAS systems on land which are becoming larger as technology develops and are now 500 – 3,300m³ per tank (Summerfelt et al, 2016) and flow regimes within these systems have been extensively studied. In a recent study of large RAS tanks on land (Gorle et al 2018), it was noted that water rotational velocities of 25 – 40 cm/sec were typical and that these are in the optimal range for fish growth; velocities tended to be greater at the periphery of the tanks because of the directional flow created by the circumferential water intakes. It was also found that by using intake arrays which distributed incoming water through the depth of the tank, regions of either turbulence or slow velocities were avoided, thereby reducing the potential for regions of low dissolved oxygen. However, the authors also noted the challenges to flow analysis created by the presence of the fish which created the greatest turbulent effect in the tanks.

Most CCSs in use or under development have greater depths than tanks in RAS units which limit the applicability of hydrodynamic models created for tanks to the design or characterisation of CCSs. Furthermore, the fluid dynamics within a flexible CCS will be even more complex than those in a rigid system, because of the changing shape of the CCS wall in response to forces acting upon the system. However, it seems reasonable to conclude that the two key requirements for the flow regime in a CCS are:

- That rotational flow speeds in circular/hexagonal CCSs are in the preferred range for optimal fish growth and performance, and,
- Inlet water is sufficiently distributed across the area and throughout the depth of the CCS to reduce the possibility of stagnant regions being created at certain points in the system.

The potential to pump large volumes of water through a CCS system at relatively low energy cost offers the opportunity to satisfy the first of these criteria and an empirical approach should allow configuration of inflow nozzles in order to address the second.

4 CCS and sea lice management

4.1 Preamble

In this section we consider:

- the current impact of sea lice infestation on marine aquaculture,
- the potential for CCS to reduce the impact of sea lice
- the financial implications of using CCS to ameliorate lice infestation

4.2 The impact of sea lice on salmon and marine trout production

Infection by sea lice (*Lepeophtheirus salmonis* and *Caligus elongatus*) is one of the greatest challenges to the Scottish salmon and marine trout sectors and has been the focus of concern to regulators and the object of considerable attention both by production companies and by the research community in their efforts to develop products, technologies and operating strategies to ameliorate the problems. The problem is ubiquitous throughout the industry and the scale and cost of the impact is considerable, with various recent analyses attributing costs of up to £0.57/kg to the costs of lice treatment and performance losses associated with that treatment (analysed in detail in section 4.4 below).

The challenge of sea lice to the industry is further exacerbated by the fact that it damages the public perception of the industry (Costello 1993) and is one of the main underlying attributes of the current industry status that attracts opposition to further development of marine aquaculture. Despite the lack of definitive scientific evidence on the issue (RECC 2018), the association between salmon farming and the increase in abundance of sea lice and the perceived subsequent infection of wild populations continues to be the aspect of marine cage farming in Scotland that provokes the most controversy and continuing well-publicised claims of the damage caused by salmon farming to wild fisheries has strengthened negative attitudes towards the industry. Indeed, it was the campaigning charity Salmon and Trout Conservation Scotland which successfully petitioned the Scottish Parliament, leading to the extensive 2018 review of salmon farming (see RECC 2018 for the subsequent report).

Evidence of poor management of sea lice infestation is also an easy target for groups which oppose fish farming in general on welfare grounds (for example FFE 2018d).

4.3 Treatments

4.3.1 Non-chemical treatment methods

The magnitude of the challenge of management of sea lice has stimulated a wide-ranging search for solutions by the production industry and substantial investments continue to be made in the development of effective methods to prevent and treat lice infestations. Broadly speaking, treatment

methods can be categorised as chemical treatments (see section 4.3.2 below) and non-chemical methods.

Non-chemical treatment methods in common use include thermal treatments (“thermolicing”), fresh water treatments (“hydrolicing”) and the co-stocking of “cleaner fish” (ballan wrasse and lumpfish) with the farmed salmon which, under certain husbandry conditions, will consume sea lice attached to the salmon.

The Global Salmon Initiative provides a comprehensive report (GSI 2018 on the various methods used for non-chemical treatments and prevention methods for the management of sea lice.

4.3.2 Chemical treatments

Various medicinal chemical reagents for the treatment or prevention of sea lice have been used over the last 20 years, both as bath treatments and as in-feed additives. With the notable exception of hydrogen peroxide, all medicinal treatments applied in Scottish marine farms are reported to Marine Scotland on a monthly and site-by-site basis and data is published on the Scotland’s Aquaculture website <http://aquaculture.scotland.gov.uk/>. The trend in the use of these chemicals from 2002 to 2017 is shown in Figure 4.1 below:

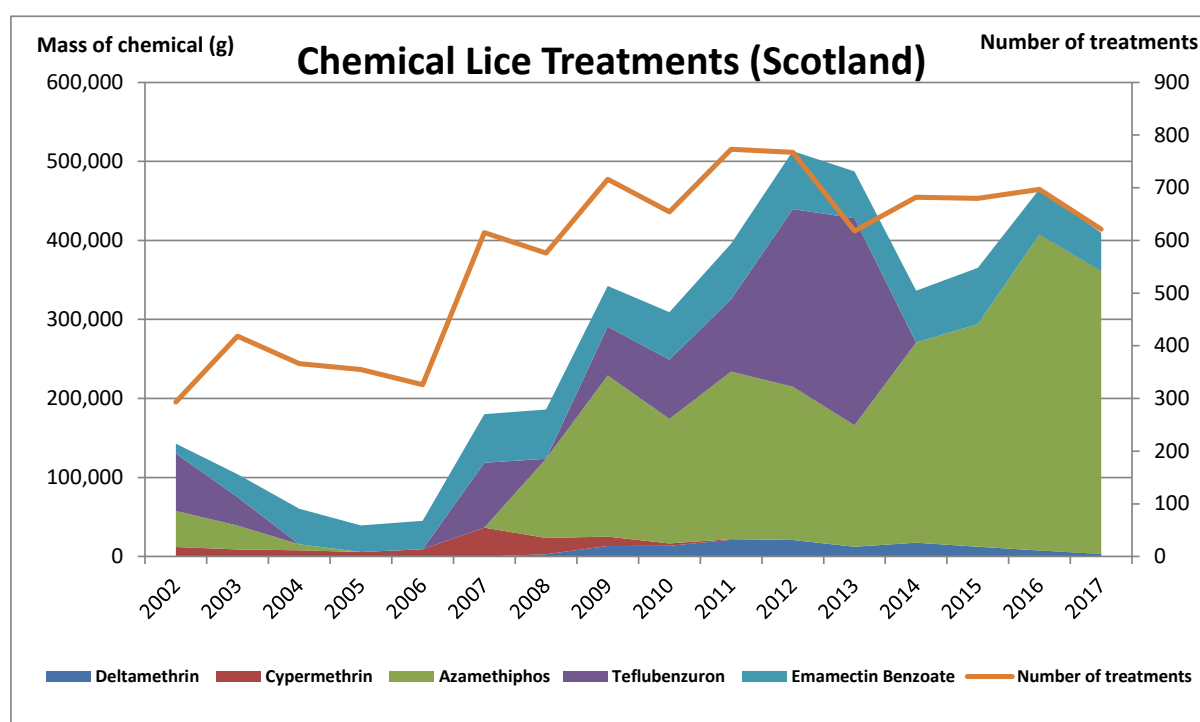

Figure 4-1. The mass of chemicals used and the number of treatments for treating sea lice in Scottish marine farms, 2002 – 2017

There was a 13-fold increase in the combined mass of active reagents used each year between 2005 and 2012 and a corresponding doubling of the number of treatments in that period. There has been a levelling-off of both mass of chemicals used and the number of treatments since a peak in 2012 and this almost certainly reflects the greater reliance upon and effectiveness of non-chemical methods of lice treatment including the use of cleaner fish and hydro- or thermolicing operations. According to EMSP News (2018) the Scottish Salmon Producers’ Organisation figures showed that sea lice levels were at their lowest in July 2018 since July 2013.

A similar pattern has been reported in Norway, with chemical use peaking in 2014; Figure 4.2 below shows the mass of fish treated per year with chemical treatments for sea lice, compared to annual production.

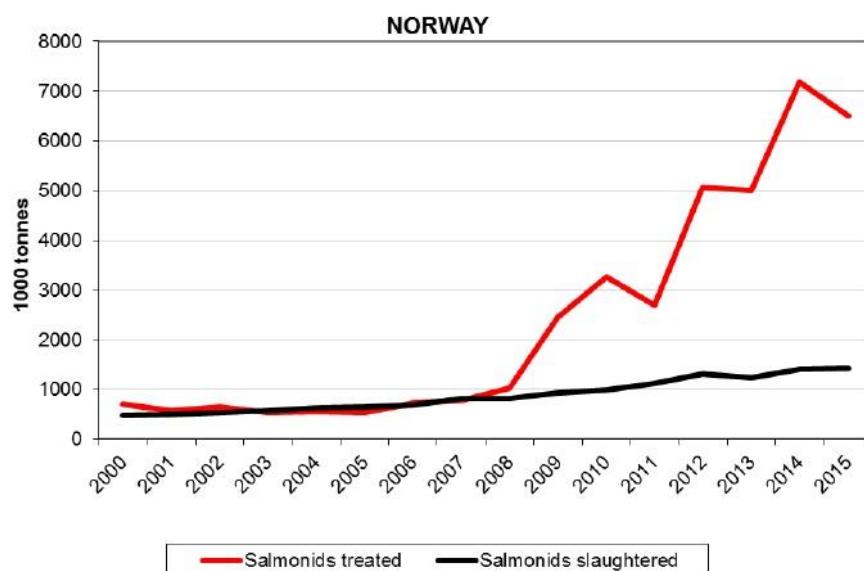

Figure 4-2. Mass of fish treated for sea lice with chemical methods and annual production in Norway, 2000 – 2015 (from Nodland 2016)

The usage of hydrogen peroxide (H₂O₂) for the treatment of sea lice in Scotland has followed a similar trend to that of pharmaceutical products (shown in Figure 4.1). Figure 4.3 shows the number of sites which have used H₂O₂ and the volume used per year.

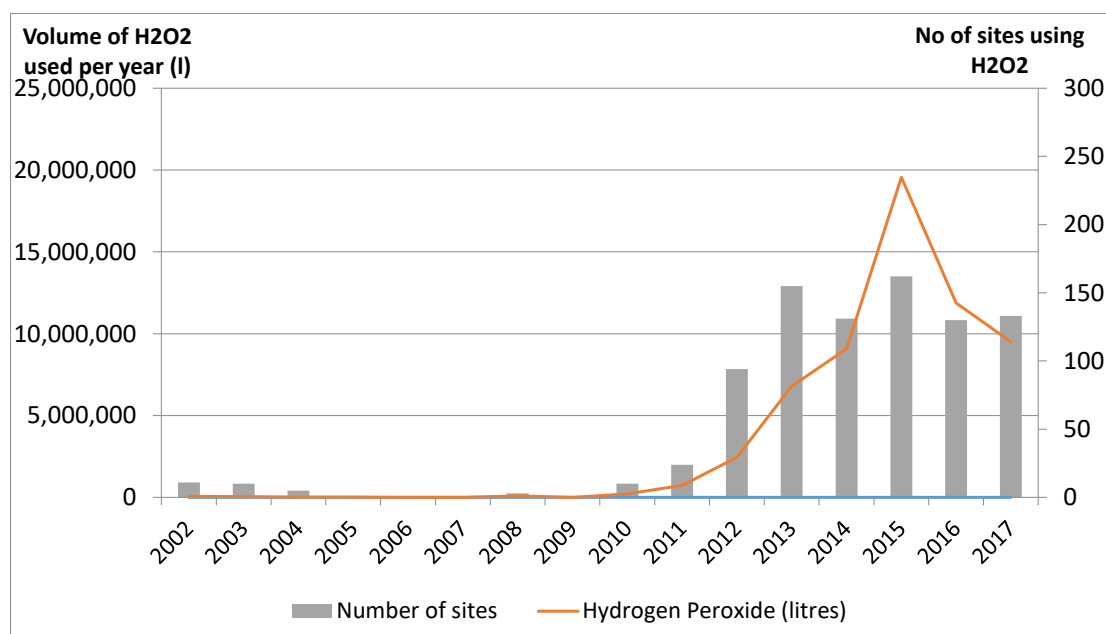

Figure 4-3: Trend in usage of hydrogen peroxide to treat sea lice (Data obtained on request from SEPA)

4.4 The cost of treatments

The derivation of a useful estimate of the cost of treatments for sea lice is complex. For bath treatments, the full economic cost includes not only the cost of the active pharmaceutical but also the labour and equipment (which increasingly utilises well boats) required for applying the treatment. For non-chemical treatments including hydrolicing and thermolicing, the costs comprise the direct operating costs as well as an allowance for depreciation of the capital investment in the specialised equipment used – which can be substantial. The costs of using cleaner fish include not only the purchase cost of the fish but also their on-going husbandry costs including feeding, monitoring, removal, slaughter and disposal.

Analysis of the costs is further complicated by the fact that current practices in sea lice treatment and management are not in a steady state (see section 4.3). Although mortalities from sea lice infestation and the expenditure on chemical treatments used have decreased since 2013, this is attributable to the use of non-chemical treatment methods such as hydrolicing and the deployment of cleaner fish, as well as the increasing use of non-chemical prevention methods such as lice skirts (see section 4.5).

Nevertheless, a number of investigations have been made into the costs of sea lice infestation of salmonid farms. Costello (2009) analysed the findings of 9 separate investigations conducted from 1993 to 2002 and noted the difficulty in making comparisons between studies as some had considered only the direct cost of treatment agents whereas others had estimated full economic costs of treatment and associated losses. More recently, estimates of the costs in Norway have been analysed - Liu and Bjelland (2014) proposed a model for lice treatment costs in Norway, which ranged from £0.21 - 0.47/kg depending on the treatment strategy used. Berle and Rim (2018) calculated the direct cost of lice treatment in Norway as NOK 1.5 (£0.14)/kg in 2011 and NOK 4.0 (£0.37)/kg in 2016. They also produced an estimate of losses attributable to reduced biomass growth as a consequence of sea lice infection and treatment of a further NOK 4.4 (£0.41)/kg.

In a detailed analysis of the costs of farmed Norwegian salmon production, Iversen et al (2015), derived a cost attributable to sea lice infestation in the Norwegian industry in 2014 as >NOK 3.4bn. The total production in that year was 1,272,358t – implying a production cost component attributable to sea lice treatments of NOK 2.67 or £0.24 per kg produced. These figures were updated by Iversen for 2015 (reported in Brooker et al 2018) to NOK 5bn for a production of 1,303,346t (NOK 3.84 or £0.36/kg).

Rødseth (2016) argues that Iversen's estimate should be extended to include lost profits attributable to lost feed and poor feed conversion as a consequence of lice infection and concludes that in 2015 the direct costs and lost profits to the Norwegian industry were between NOK 7bn and 8bn (between £0.50 and £0.57 per kg produced).

Estimating *pro rata* on the basis of the higher estimate, implies a cost to the Scottish industry in 2015 of £85 – 90m and at the lower estimate, excluding lost profits attributable to lost feed and poor feed conversion as a consequence of lice infection, £0.36/kg - a total cost of £61.26m.

4.5 Potential of CCS to reduce sea lice infestation

One of the design features of floating closed containment systems (reviewed in section 3) is that intake water for the system can be pumped from depths below those at which sea lice are typically found.

Ideally then, a novel system design would be based upon a robust scientific understanding of the factors which control the presence of sea lice including knowledge of the production, dispersal and development of the free-swimming non-infective nauplii and infective copepodid larval stages of lice; however, despite more than 30 years of research, knowledge in this area remains extremely poor (Brooker et al 2018). According to Brooker, we do not yet have an adequate model of larval dispersion and infectivity based upon physical processes and biological activity. Nilsen et al (2016) note that the location of the planktonic stages is influenced by diffusion, swimming activity, light and salinity. A model study by Johnsen et al (2014) cited by Nielsen et al (2016) argues that if nauplii and copepodites react first to light and salinity, the “safe” depth for water intake to a CCS would be below 10m in the summer and below 15 to 20m in the winter. However, if temperature is the predominant factor determining vertical movement, the “safe” depth would generally be below 20m but with a risk of nauplii being found as deep as 40m during the winter.

There is an increasing body of applied reports and practical evidence of the reduced incidence of infective lice at deeper levels and of effective husbandry techniques which exploit this characteristic to reduce lice infestations. This has been shown in various studies and trials using “lice skirts” and “snorkel cages”.

Lice skirts are impermeable or semi-permeable fabric cylinders, suspended as concentric barriers outside the net of floating pens and obstructing flow through typically the upper 6m of the cage (Figure 4.4).



Figure 4-4. A typical lice skirt arrangement (from FFE 2018)

The underpinning assumption is that the mobile stages of lice are mostly found near the surface so the skirt will prevent lice in that region from entering the cage and finding a host fish. Water exchange is effected by flow, mixing and diffusion from the lower portion of the cage; some semi-permeable fabrics have been used as lice skirts on the assumption that water and dissolved oxygen can pass through the membrane whilst the passage of lice is blocked (FFE 2018).

Grøntvedt et al (2016) carried out a field study using 6 and 10 meter deep plankton nets (350µm mesh) as lice shields. Significant reduction of lice infestations were found using both 6 and 10 m nets, with the largest effect being obtained from the 10m net. There were no significant effects measured

on oxygen concentrations within the shielded cages or negative health conditions measured in the fish.

Scottish Sea Farms reported the successful use of 6m lice skirts around conventional cages (FFE 2018) which reportedly kept sea lice levels below the treatment thresholds for 9 months with the salmon showing strong growth and biological performance. This was part of an £111.8m drive in 2017 to enhance health and welfare – over 85% of which was to be spent upon non-medicinal approaches.

Snorkel cages are modified conventional net cages fitted with a “ceiling” panel which constrains the fish to the volume of the cage beneath the pre-set depth of the ceiling net panel. The ceiling panel has a “snorkel tube” outlet made of an impermeable material to the surface which allows the fish access to the surface to gulp air to re-fill their swim bladders (Figure 4.5).

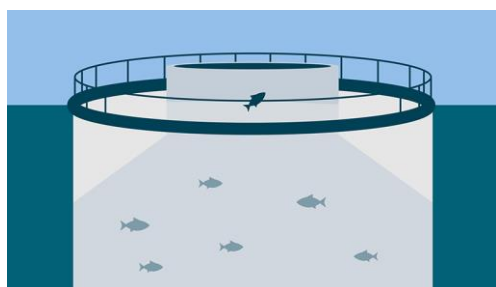

Figure 4-5. Concept drawing of full-scale “Snorkel cage” (from <https://globalsalmoninitiative.org>)

Oppendal et al (2017) studied lice infestation in snorkel cages using snorkels at depths of 4, 8, 12 and 16m and reported that lice infestation decreased exponentially with depth in all time periods. Infection levels in cages with shallow snorkels (0 and 4 m) were consistently 4–10 times higher than those in deep snorkels (12 and 16 m). Key welfare and production performance indices were similar across all snorkel depths.

Whilst lice skirts and snorkel cages can reduce lice infestation through the use of a limited physical barrier, the potential for lice interaction with the fish remains at cage depths not protected by the barrier, or at higher depths through the effect of mixing. The concept of a closed containment system with water intakes positioned below the depth regarded as the maximum at which lice are found offers a more effective means of prevention against lice infestation.

Nilsen et al (2016) conducted long-term experiments to investigate sea lice infestation in floating closed containment systems at pilot scale (3,000m³ cages) at two sites over three years. The water supply was pumped from a depth of 25m. Moderate to high infestation was measured in control cages (non-closed containment), whereas in the closed containment systems sea lice were only recorded after fish had been moved between cages with well boats, or when the cages were stocked with fish transferred from open cages. When fish were exposed to sea lice in the closed cages, the recorded abundance was low and with no signs of sea lice reproduction within the cages.

There are many CCS systems under development and trial, mainly in Norway, and there is much anecdotal evidence of the efficacy of these systems in reducing or preventing lice infestation. Of course, these trials are rarely set up as rigorous scientific experiments with controls as they are typically focused on the performance and operation of the system itself rather than an isolated aspect of fish performance within the system. Also, trial results are usually reported in the aquaculture trade press or on company press releases, rather than in peer-reviewed journals. Nevertheless, there is a compelling picture emerging supporting the efficacy of CCS in the prevention of sea lice infestation.

Almost every trial in pilot CCS systems has reported very positive results with either no lice counted on fish held within CCS systems or, very low numbers. Lerøy has published results on their website of 3 production cycles of post-smolts in trials using the Preline CCS (Lerøy 2018); In 2018, Marine Harvest moved its first batch of 200,000 post-smolts reared in a “Neptun” CCS nursery at Molnes to open sea pens and reported “no problems with sea lice” (FFE 2017c); and Norwegian salmon farmer Sulefisk reported growth of post-smolts to 800g in an Ecomerden system “without seeing any sexually mature female lice and without any kind of lice treatments”(FFE 2017d).

4.6 The potential impact of using CCS nurseries on lice costs in Scotland

The use of lice treatments in conventional systems is carried out as necessary throughout the entire growout cycle, though levels of lice infection tend to increase after 12 months of production. We have attempted to estimate the costs of lice treatment in Scotland which could potentially be saved by the use of floating CCS nursery systems from the frequency and timing of various treatments and from the estimated cost per treatment type.

The frequency of use of various pharmaceutical chemical agent treatment was obtained from data from Scottish sites; the frequency of non-pharmaceutical treatment use in was derived from published work (Hjeltnes et al 2017) which reported the typical ratio of pharmaceutical use to non-chemical treatments and to hydrogen peroxide use by Norwegian farms.

The cost of each treatment type was estimated from the findings of Iversen et al (2015) and Jeffery et al (2014) (for hydrogen peroxide use).

As a condition of their SEPA licence, farms are required to report pharmaceutical treatments by site on a monthly basis. That data is available on line at Scotland’s Aquaculture website http://aquaculture.scotland.gov.uk/data/fish_farms_monthly_biomass_and_treatment_reports.aspx. The use of hydrogen peroxide treatments or non-chemical treatments is not reported.

We have assumed that for the period post-smolts are grown in CCSs, there will be no lice infestation and hence, no need for treatment. We have analysed the recent pattern of lice treatment regimes in Scotland in order to produce an estimate of. A full description of the analytical process is given in Appendix five.

The comparison here is between a conventional sea cage ongrowing site, stocked with ~100g smolts (the “Base case”), and a conventional ongrowing site which is fed by ~1,000g post-smolts from a separate CCS system (the “CCS” option).

The analysis of pharmaceutical chemical treatments is based upon the monthly reports of treatments recorded on the Scotland’s Aquaculture/SEPA web-based data resource for the 22 marine salmon sites in Scotland with an allowable biomass limit of $\geq 2,499t$ which were active with >1 production cycle within the last 5 years. By reviewing monthly biomass data and treatment records it was possible to derive the number of treatments for each pharmaceutical product for two periods – set as the first 7 months in sea cages (this being representative of the likely period of use of CCS) or from month 8 onwards - and the mass of each product used. This data is presented in Table 4-1:

Table 4-1. Frequency and mass of treatments for various pharmaceutical chemical treatments at Scottish sites with >2,499t MAB

Site Status	Total number of treatments	Average treatments per site per month	Mass of active chemical per treatment
Deltamethrin (Alphamax)			
First 7 months in sea cages	18	0.05	96 g
Remaining time spent in sea cages	88	0.14	99 g
Azamethiphos (Salmosan)			
First 7 months in sea cages	16	0.04	1,490 g
Remaining time spent in sea cages	135	0.21	2,124 g
Emamectin Benzoate Used (Slice)			
First 7 months in sea cages	98	0.27	149 g
Remaining time spent in sea cages	64	0.1	421 g

The frequency of hydrogen peroxide, mechanical treatments and cleaner fish treatments was derived from Hjeltnes et al (2017) as follows:

Table 4-2. Ratio of mechanical treatments and H₂O₂ treatments to medicinal treatments in Norwegian sites, 2015-16 (from Hjeltnes et al 2017)

Treatment	Number
For each medicinal treatment including deltamethrin/cypermethrin, emamectin benzoate, azamethiphos and teflubenzuron	1
Hydrogen peroxide treatments	0.56
Mechanical treatments (hydrolicing or thermolicing)	0.49

Values assigned to the costs of various treatments were obtained from Iversen et al (2015) as follows (Table 4-3). These costs were derived from consideration of raw materials, labour and equipment use but not including reduced performance as a consequence of lice infestation and treatment.

Table 4-3. Costs of various treatments

Description	Main Ingredient	Price	Treatment Cost per 1,000,000 fish treated
Chemical bath treatments	(Various e.g deltamethrin, azamethiphos)	0.0552 £/fish	£55,200
Paramove	Hydrogen Peroxide	0.0864 £/fish	£86,400
In-feed**	Emamectin Benzoate	£800/pen	£8,000
Cleaner fish	Wrasse or lumpfish	0.216 £/fish treated	£216,000
Thermolicing/ Hydrolicing	Warm Water/Freshwater	0.11 £/fish treated	£102,600

** Cost estimate from Jeffery et al (2014)

Using these costs, the frequency of the various treatments from the analysis of the Scottish data and the assumptions about the frequency of use on non-chemical treatments from Hjeltnes et al (2017), we have derived costs for the base case and the situation where the CCS nursery is feeding the ongrowing site with 1,000g post-smolts. Based on the available evidence, we have assumed no lice treatment costs for the period in the CCS nursery.

It was assumed that for the base case, treatments were required as reported in Table 4-1 (for 7 months at initial rates, followed by 13 months at the latter treatment rates). For the comparison with the CCS configuration, two cases have been derived; in the first case, it has been assumed that the treatment regime required for 13 months would be similar to those used in the latter part of the base case production cycle – however, it is likely that this would over-estimate the frequency of treatments needed for this stage as infestations are reportedly worse for cages during their second year at sea Lees et al 2009 (which is avoided in this option). In order to account for this, the effect of an arbitrary 20% reduction is also considered in the second CCS case.

The derived costs for lice treatment are shown in

Table 4-4. Derived costs of lice treatment for various production scenarios based on 4,000 t production from 1,000,000 stocked fish. The calculations are based on a cycle in a 2,500t MAB site, producing 4,000t from 1,000,000 stocked fish.

Table 4-4. Derived costs of lice treatment for various production scenarios based on 4,000 t production from 1,000,000 stocked fish

Treatments (Costs) per production cycle			
	Conventional grow-out ("Base case")	If CCS nursery is used	If CCS nursery is used AND there is a 20% reduction in ongrowing treatment costs
Medicinal treatments (Deltamethrin and Azamethiphos)	£285,936	£251,160	200,928
In-feed treatments (Emamectin Benzoate)	£25,520	£10,400	£8,320
Hydrogen Peroxide Treatments Required (0.56 x number of medicinal treatments total @ £86,400/treatment)	£404,974	£283,046	£226,437
Mechanical Treatments required per cycle (0.49 x number of medicinal treatments) @ £102,600/treatment)	£420,793	£294,102	£235,282
Cleaner Fish Utilization Scenario 1 - assuming going from cleaner fish used for Conventional every cycle to no cleaner fish used for CCS)	£216,000	0	0
Cleaner Fish Utilization Scenario 2 - assuming no reduction in cleaner fish used	£216,000	£216,000	£216,000
Total Cost – Scenario 1	£1,353,223	£838,709	£670,967
Total Cost – Scenario 2	£1,353,223	£1,054,709	£886,967

Cost / kg produced – Scenario 1	£0.34	£0.21	£0.17
Cost / kg produced – Scenario 2	£0.34	£0.26	£0.22

Scenario 1 assumes no treatments of any type for the first 7 months (in CCS), followed by treatments reduced by 20% from the conventional pattern of use in conventional growout for all treatments except cleaner fish which are not used. In that case, the saving by using the CCS nursery is £0.17 per kg produced. If the 20% reduction in treatments after transfer is not included, the saving is reduced to £0.13 per kg.

Scenario 2 assumes no treatments of any type for the first 7 months (in CCS), followed by treatments reduced by 20% from the conventional pattern of use in conventional growout for all treatments except for cleaner fish for which there are no reductions in cost. In that case, the saving by using the CCS nursery is £0.12 per kg produced. If the 20% reduction in treatments after transfer is not included, the saving is reduced to £0.08 per kg.

5 CCS and waste management

5.1 Preamble

One of the main benefits associated with the use of CCS is the potential for the collection and treatment of the effluent from the system, thereby potentially reducing the impact of the culture activity on the local environment. The waste from cage fish culture is composed of excreted metabolites in soluble form including ammonia, nitrites, and excess dissolved carbon dioxide and nitrogen and solid wastes including egested faeces and uneaten feed particles.

Most CCSs in use or under development incorporate a waste sump at the lowest point in the system, from which a concentrated stream of waste water with relatively high solids loading can be pumped, either continuously or intermittently. The design aim is that “settleable” particles, generally considered as particles >100µm in size, will collect in the waste sump (Summerfelt 1999), whilst dissolved nutrients and non-settling, supra-colloidal solid particles (1-100µm in size) exit from the system into the environment through the outlet ports which will generally be higher in the system than the solids sump (Boulet et al. 2010; Summerfelt 1999).

The removal of the soluble waste metabolites from culture water can be achieved in land-based recirculating aquaculture systems through the use of biofilters and other physical means. To date though, no floating CCS design has been developed that includes water re-use to any great extent. A common feature of all designs implemented at scale is that the oxygen requirements of the fish are provided entirely through a pumped supply of water. Consequently, there is a high flushing rate of the culture water so the soluble waste metabolites are of little concern in terms of their impact on the health of the fish in the system. Of course, by releasing the culture water through the system outlets into the surrounding ocean there is a potential impact on the environment; however in flushed marine environments, the soluble fraction of fish culture wastes is generally regarded as being of far less concern than the solid fraction. The regulation of the biomass allowed at any licensed site and the use of chemical agents is determined by SEPA using the measured and projected impact of the accumulated solid waste on the benthic environment, with limited regulation of the release of dissolved and non-settling nutrients (SEPA 2017).

This section considers the methods that have been, or could be used to collect the solid waste fraction from CCSs and the options available for the treatment and use or disposal of that waste material. Using a theoretical model study, we derive potential capital and operating costs for the various options and consider the logistical and regulatory limitations to those options in Scotland.

5.2 Details of waste collection systems used in land-based aquaculture systems

NB The principles of operation of waste processing system components (marked thus*) mentioned in this section are explained in Appendix six.

In land-based systems, solids are typically released intermittently as a waste liquid stream (0.5% total solids (“TS”)) to either a settling tank or a separator/filtration unit (e.g. swirl separator* or drum filter*) (Summerfelt and Penne 2007; Summerfelt 1999). In an appropriately-sized settling tank, waste

particles will settle and form a sludge blanket at the bottom of the tank. The clarified water at the top of the tank can be discharged or, in the case of RASs, returned to the system for the removal of soluble metabolites before re-use, whilst the sludge from the settling tank can be regularly removed and further processed (eg, sent to a municipal waste water treatment plant) (Summerfelt and Penne 2007; Summerfelt 1999).

Microscreen filters (e.g. rotary drum filters*) separate particles from the waste stream, producing a “cleaned” effluent stream; solids are removed by scraping and back-washing from the screen and diverted for further treatment intermittently or continuously via hydraulic flushing (which provides a waste stream with 1–6% TS) (Metcalf & Eddy 2004; Summerfelt 1999). Rotary drums are particularly useful in for aquaculture wastes because they can remove solids from large volumes of flow, whilst taking up a small footprint, although they do have associated operating and maintenance costs (Summerfelt 1999). Mesh sizes of 60–100µm are typically used in aquaculture applications. Negligible benefits and higher maintenance have been associated with the use of mesh sizes below 60µm (Cripps and Bergheim 2000).

Once separated by a rotary drum filter, solid waste streams can be transferred to smaller settling tanks than would have been necessary for un-filtered waste streams or can be dewatered using a centrifuge*, belt-dryer or filter press, thereby concentrating the solids into a 15–35% TS cake (Scanship 2018; Summerfelt 1999). This solid cake may then be further processed into a useful product (e.g. compost), utilised for energy generation (e.g. through incineration or anaerobic digestion (AD)) or dried to facilitate easier transport and handling (e.g. transport to landfill).

Summerfelt and Penne (2007) analysed the use of a system to treat solid waste from an RAS farm in which the RAS waste stream was filtered by a 60µm rotary drum, and the collected solids intermittently backwashed into a septic tank. The system had a minimum 24 hour retention time, retained 70% of the total inlet solids, 60% of inlet nitrogen and 40% of inlet phosphorus.

Scanship, a Norwegian company which specialises in the design, manufacture and management of waste handling systems for cruise ships, offers a complete solids handling system designed for RAS solids collection (Rohold 2018). The 0.5% TS influent is put through a belt filter (concentrating the stream to 5–10% TS), dewatered in a decanter centrifuge (25–30% TS), and dried (to 85% TS) in a batch dryer (Scanship 2018a). They suggest the dried solids could be used for soil enhancement, heat and energy recovery (e.g. AD or incineration), or as a feed material for other industrial applications (e.g. phosphorus recovery) (Scanship 2018a). The company has adapted its technology for salt water systems and has recently been awarded a contract with Akvafuture to collect, process and dry sludge from their CCS cages at three testing sites (Scanship 2018b)

5.3 Waste collection systems currently in use in floating CCS aquaculture systems

As can be seen from the review (section 3) of closed containment systems currently under development, most activity is in the commercial domain and the pace of development is quite fast. Consequently, there are few peer-reviewed accounts of design and performance of systems under controlled conditions and most accounts of design and operation can be found in industry news publications and companies’ own publicity material. From our review of floating CCSs under development it is apparent that there are very few details published of waste collection and treatment systems. Whilst many of the currently active companies claim that CCS is more environmentally-

friendly then open net-pens because the solid waste *can* be collected and treated, they provide little to no information on what equipment is used or how this is, or might be accomplished.

Considering the systems below:

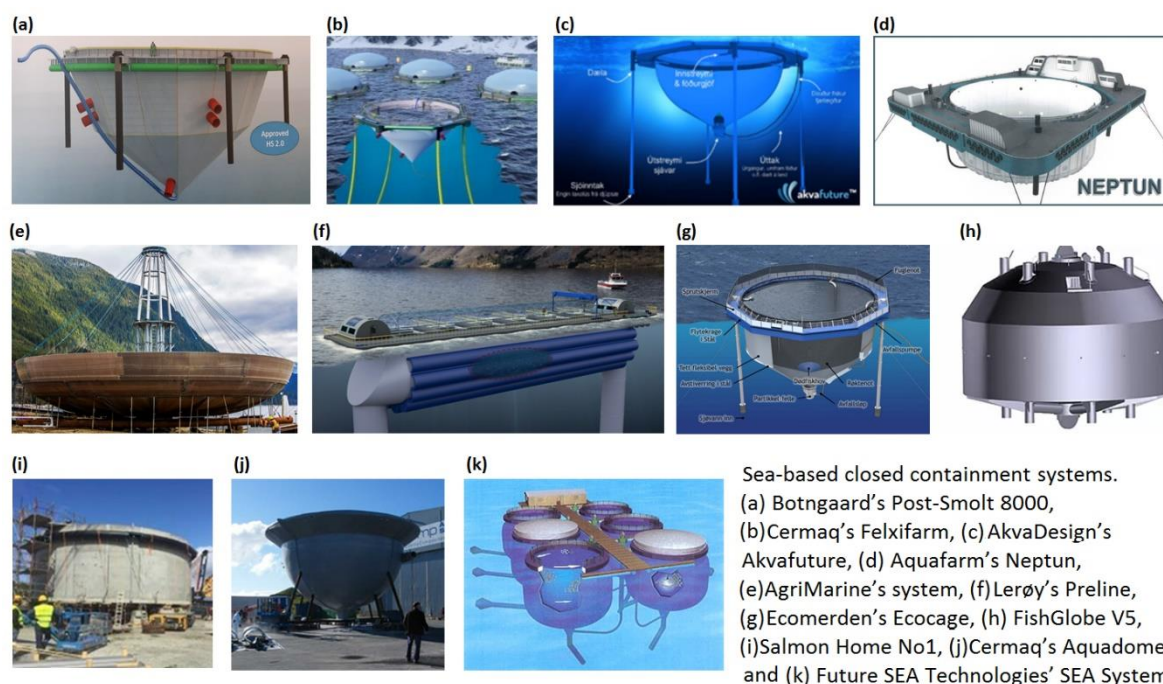

The descriptions of waste collection and treatment are as follows:

Table 5-1. Descriptions of waste collection and treatment from various commercial CCS

System	Description of waste collection and/or treatment from press or company literature	Information sources
a) Botngaard Closed Post-Smolt Cage	Waste is released from the system bottom into the sea. Waste can be collected with a pump and/or collected and dispersed over a wider area through a hose.	Botngaard 2018a; Botngaard 2018b
b) Cermaq Flexifarm	Solids are ground up and dispersed into the ocean to prevent concentration of solids directly beneath the system, or discharge can be passed through a filter, the solids collected and processed further on shore.	Cermaq 2017; Fish Farming Expert 2017
c) AvkaFuture's AkvaDesign	Solids collected from bottom of the cage and used as fertiliser or biofuel. 'Can reduce the fish waste which goes into the water by 70%'	AkvaDesign 2014; Haaland 2017; Ramsden 2017a
d) Aquafarm Neptun	States salmon faeces is not a problem for the seabed, but represents an untapped resource. 60-70% of organic waste produced is collected (goal is to increase to 80-90%). Waste is collected then re-used by other companies, and is suitable for use as a fertiliser, a soil improvement supplement, a bio-gas producer, a concrete additive, or for phosphorus extraction.	Aquafarm Equipment 2017; Aquafarm Equipment 2018; Fish Farming Expert 2017

System	Description of waste collection and/or treatment from press or company literature	Information sources
e) AgriMarine	Systems are fitted with a proprietary solids capture and concentration system ('Nutrient Recovery System') and waste is converted into input for the production of organic fertilizer.	Agrimarine Technologies 2015; Grydland 2012; Haaland 2017; IntraFish 2009; IntraFish 2011; The Fish Site 2009
f) Lerøy Preline	Waste feed and faeces collected as sludge in 'mud traps', first trialled in 2016. "Possible to collect faeces", "Regulation-compliant collection of waste", "Possibility to use sludge as resource", but no specific details. Mud trap design identified as a challenge.	Lerøy Seafood 2017; Preline 2016
g) Ecomerden Ecocage	Labelled diagrams of system show a particle filter (partikkle-felle) and a waste pump (Avfallpumpe), but no details of operation. "mud pump installed in the middle of the cage"	Blaalid 2014; Ecomerden 2016; Ramsden 2017b
h) Fish Globe V5	'You can collect particles such as fish waste' – no further info available.	Fish Globe 2018; Hosteland 2017
i) Salmon Home No1	"Faeces are constantly accumulated in the bottom and taken out of the tank." Fish waste is considered an important resource that can be processed for biogas, fertilizer, phosphorus recycling, or burned in cement kilns in place of coal.	Fish Farming Innovation 2016b; Haaland 2017; Hosteland 2016
j) Cermaq Aquadome		
k) Future SEA Technologies SEA System	NB It is unclear if this was ever done at full scale, but only lab-scale. Solids were collected from a concentric drain at the bottom of the culture bags, and transferred to waste bags which were pumped out by service vessels once per week. Sludge is transferred at dock to a sewage truck which removes sludge for treatment, land application or composting.	Boulet et al. 2010; Chadwick et al. 2010

5.4 The use or disposal of concentrated fish waste from floating CCSs

Once collected, the concentrated solid waste must be utilised or disposed of. Under the present Scottish regulatory system, the waste from a CCS system would not be considered an animal by-product (ABP) because fish faeces and processed animal protein (i.e. the fish meal found in uneaten feed) are excluded from ABP regulations (EU Regulation (EC) No 1069/2009 2009; APHA 2018). This classification increases the options for utilisation and disposal and reduces the potential cost, without

requiring significant amounts of additional treatment and with less strict regulatory requirements as would be necessary for an ABP (EU Regulation (EC) No 1069/2009 2009).

As mentioned above, there is a lack of useful data available on the use or disposal of solid waste from full-scale CCSs; however, there are several potential end-uses and methods of disposal of marine aquaculture solid waste which have been investigated by others at experimental or pilot scale. These include drying, followed by Incineration, disposal in landfill, anaerobic digestion, composting or land application.

Incineration of aquaculture solids could be carried out on land sites adjacent to CCS marine sites, with EU-regulation-compliant incineration units designed for aquaculture applications commercially-available from the UK company Addfield Environmental Systems Ltd (Addfield 2018a). These incinerators can be fitted with waste-to-energy systems which produce thermal and electrical energy that could be used on the CCS site to supplement or replace the process energy requirements (Addfield 2018d).

Dried CCS solid wastes can be transported to and disposed of at landfill sites; however because of the associated transport and gate fee costs, and the lost potential of the waste to be utilised, recycled or recovered, this is generally considered a choice of last-resort (EU Directive 2008/98/EC 2008; SEPA 2015a; Summerfelt 1999).

Many of the other utilisation methods available for solid wastes material of organic origin (e.g. anaerobic digestion, composting or land application) rely upon biological processes, which may be slowed down or damaged by the high salinity levels normally present in CCS solid waste from marine culture systems (Mirzoyan et al. 2010; Yeo et al. 2004; Zhang et al. 2013). This does not mean that CCS solids cannot be used for these processes, but they would either need to be diluted by mixing with other suitable feedstocks for these processes (e.g. by mixing CCS solids with cow manure prior to adding it to an AD), or research, development and monitoring would be required to optimise the processes (e.g. for composting) or to ensure no damage was done (e.g. through land application) (Rohold 2018).

Anaerobic digestion is a process in which microorganisms break down organic waste in the absence of oxygen, producing methane gas and a stabilised sludge product (Metcalf & Eddy Inc. 2004). Fish sludge from freshwater, brackish and marine RAS sites has been used successfully to produce methane gas via AD (Gebauer 2004; Mirzoyan et al. 2010; Zhang et al. 2014). Salinity has been shown to reduce the efficiency of sludge digestion, but dilution (e.g. with fresh water), or the use of high salinity-adapted inoculums for AD have been shown to improve performance (Gebauer 2004; Zhang et al. 2013). Small-scale, on-site biogas production facilities are commercially available, but consideration of the relatively high capital and operating costs and the complex nature of their operation meant that for this study, the transport of waste to centralised AD systems (of which there are many in Scotland) was considered the more realistic option (NNFCC 2018; Sterner 2018b).

In windrow composting, long piles of waste materials are formed and left to breakdown by a thermophilic process in which microorganisms degrade organic components, producing a more stable waste product which has potential use as a soil amendment or plant growth media (SEPA 2015b; Yeo et al. 2004). Composting has been shown to be a viable method of processing freshwater aquaculture manure, but there is little information available in the literature concerning its use for processing marine aquaculture solid wastes (Adler and Sikora 2004). The high maintenance and land requirements associated with composting and the availability of commercial, centralised, off-site composting facilities in Scotland, meant that transporting the waste to off-site facilities was considered for the analysis in this study (SEPA 2015c; WRAP 2016).

In order to accept and process fish wastes, disposal sites must have a pollution prevention and control (PPC) licence (SEPA 2018a). Potential sites for the disposal of solid waste originating from marine CCS operations including landfill, composting, incineration and anaerobic digestion facilities, were identified through consultation with SEPA, and by using SEPA's waste sites and capacity data tool (SEPA 2016b) & NNFC's Biogas Map (2018). These sites are shown in Appendix Eight. In general, these disposal sites are concentrated in the Central Belt and along the east coast, and some disposal locations would be inaccessible except by ship from certain aquaculture sites (eg composting or AD in Shetland). The SEPA tool lists fewer suitable anaerobic digestion sites compared to the biogas map, which includes sites with much lower capacities and also includes information on the type of waste accepted by the sites (27 out of 31 shown accept animal faeces).

Land application of fish solids from freshwater trout and salmon operations has been shown to have ecological and agricultural benefits (Celis and Sandoval 2010; Smith 1985; Yeo et al. 2004) and the application of saline biosolids from shrimp aquaculture has been shown to have value as a fertilizer for bell pepper and broccoli production (Dufault and Korkmaz 2000; Dufault et al. 2001). However, in order to be directly applied to near-by land, CCS solid waste would need to demonstrably result in agricultural benefit or ecological improvement, and long-term monitoring and validation would be required (UK Environment Agency 2010).

5.5 Model System for Analysis

5.5.1 Model development

In order to investigate the potential costs of waste capture and treatment from a post-smolt CCS we have considered a hypothetical CCS of 6,000m³ capacity (we have used the same model throughout this study – eg, for the calculation of production costs, capital costs and so on). This capacity was chosen as typical of systems which are currently at the advanced stages of trialling or are commercially available and are entering use (in Norway).

As this is a theoretical exercise we have used a conceptual physical model of a single CCS with its own waste collection and primary waste processing system. As CCSs become better developed and enter routine use, they are likely to be deployed in groups of, say, 6 CCSs in which case there are likely to be economies of scale realised by sizing waste handling and treatment equipment for larger volumes as well as shared plant for, say, water and electrical energy supply.

In this analysis we are only concerned with the costs associated with waste capture and processing. The other operating and capital costs associated with the system are considered elsewhere in this report.

We have calculated the mass of solid waste and rate of production based on the results of Cripps and Bergheim (2000) and del Campo et al (2010) who found the relationship between the mass of faeces produced and the mass of feed fed to be in the range 15% - 35%. Reid et al. (2009) calculated the rate of feed wasted in marine salmon cages to be 3 - 5%. For the purpose of this study, we used values of 25% and 5% for faeces produced and feed wasted respectively.

Growth rates and feeding rates have been calculated from a growth model which is described in detail in section 6 and Appendix seven.

We have considered a system in which the solid waste fraction settles to a collection sump from which it is pumped to a partial de-watering system incorporated on the floating CCS. The partial de-watering is necessary to avoid the need to transfer large volumes of low-concentration waste to shore for the complete de-watering and treatment process.

The CCS-based waste treatment system is shown as a block diagram below (Figure 5-1):

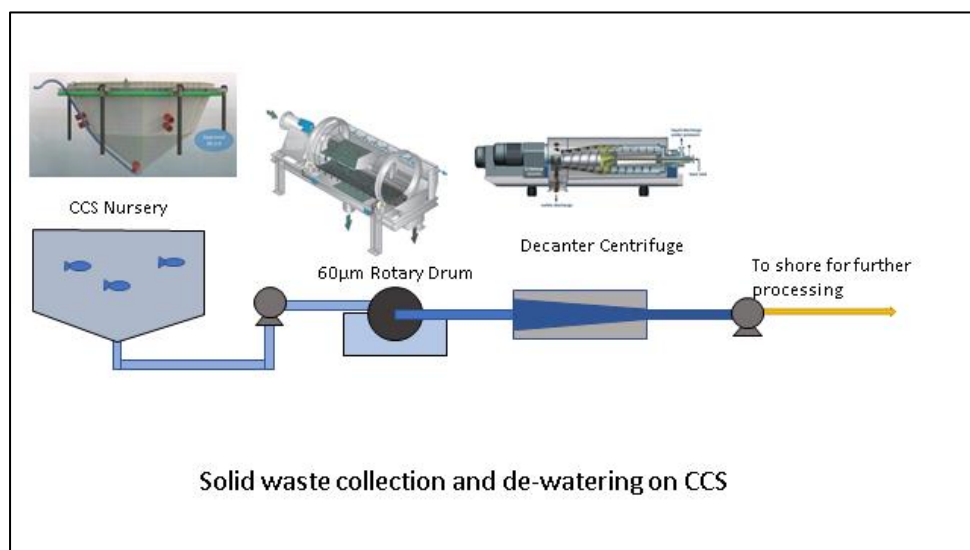

Figure 5-1. Solid waste collection and de-watering on floating CCS

We have investigated the potential performance of each the system components from the literature and the derived performances are listed in Table 5-2 below:

Table 5-2. Theoretical performance of CCS waste collection and de-watering system components

Assumption	Value Used For Calculation	Range	Sources
% of settleable solids > 100µm – in total solid waste reaching the sump	80%	77 – 87%	(Brinker 2007; Cripps and Bergheim 2000; Unger and Brinker 2013)
Concentration of solids pumped from CCS sump	0.5%	0.1 – 0.2% 0.57% 0.5%	(Scanship 2018; Sharrer et al. 2010; Summerfelt and Penne 2007)
Collection efficiency of 60µm rotary drum	95%	67 – 97 %	(Cripps and Bergheim 2000)
Concentration of solids after rotary drum	2%	0.5% (for very dilute RAS streams) 4-5% (based on mass balance /backwash rates) 0.5 – 6%	(Metcalf & Eddy Inc. 2004; Summerfelt 1999; Yeo et al. 2004)
Centrifugation Solids Capture	90%	75-90% >95% (requires chemical addition)	(Metcalf & Eddy Inc. 2004)
Concentration of solids leaving centrifuge (for septic tank)	10%	8 – 12%	(Metcalf & Eddy Inc. 2004; Scanship 2018)

The performance values derived for the on-CCS de-watering process from these assumptions is shown in Figure 5.2 below:

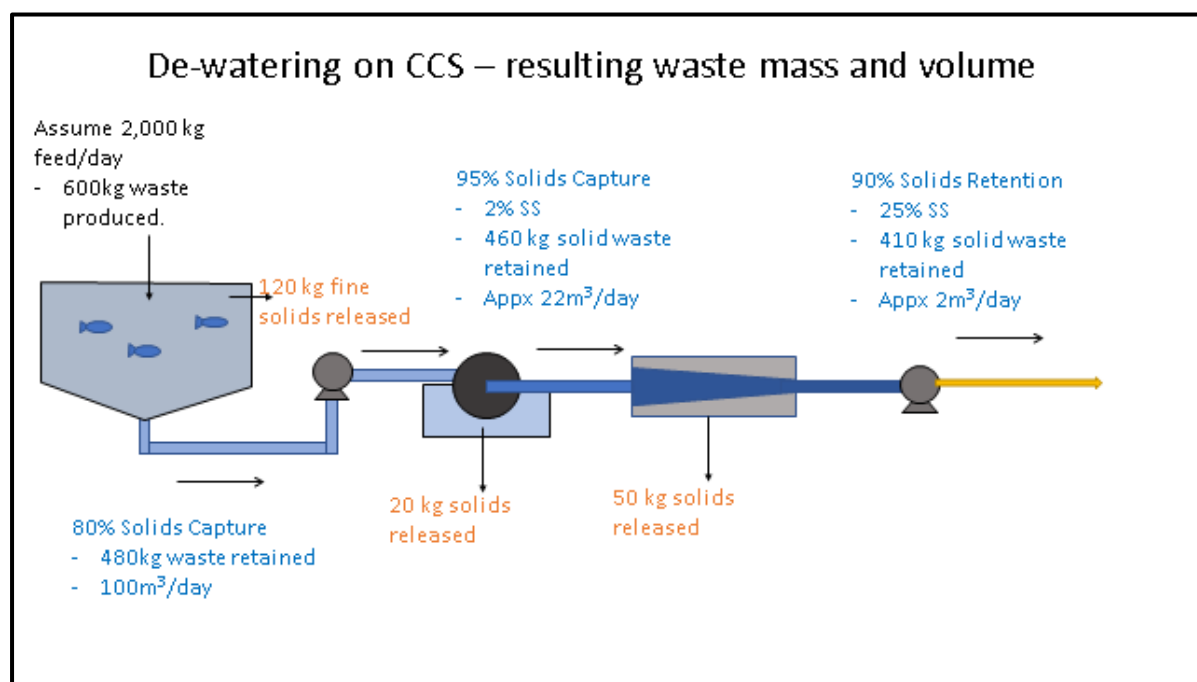

Figure 5-2. Performance values derived for the on-CCS de-watering process

5.5.2 Sizing calculations

It can be seen that from 600 kg/day of solid waste released in the CCS (the approximate maximum load in a cycle), 120 kg is released as non-settleable particles to the environment and 480 kg is retained, eventually as a ~25% SS concentration in ~2m³/day slurry. Depending on site conditions and layout, this could be pumped ashore or transferred in batches to vessels for transport to shore by workboat for further processing.

The total solid waste produced per 6,000 m³ CCS unit per production cycle will vary according to the initial stocking date as the time in the system to achieve the target weight will differ. The shortest cycle will result from a quarter 2 deployment of 100g smolts. The total waste produced per cycle and the total mass of solid waste produced per cycle is shown in Table 5-3 below:

Table 5-3. Solid waste produced from a single 6,000 m³ CCS unit, per cycle

	Q2 Deployment (BL) Apr. 1 st	Q1 Deployment Jan. 1 st	Q3 Deployment July 1 st	Q4 Deployment Oct. 1 st
Days until start of harvest	182	238 (+30.8%)	161 (-11.5%)	245 (+34.6%)
Total waste produced over nursery cycle (kg)	27,100	28,500 (+5.2%)	26,920 (-0.7%)	27,800 (+2.7%)
Processed waste produced (for shore-based treatment) per cycle (kg)	18,518	19,475	18,395	18,997

The further processing options at a land base that have been considered are as follows (Table 5-4):

Table 5-4. Options considered form land-based waste processing and disposal

Shore facility equipment	Operation	Project Code	Cycle details
Batch Dryer	Transport to landfill	MCLF	After drying, solids are stored on site before being transported via large transport truck (10-tonne capacity) and disposed of at the nearest landfill twice per CCS per nursery cycle.
Batch Dryer	Transport to anaerobic digestion	MCAD	After drying, solids are stored on site before being transported via large transport truck to the nearest suitable anaerobic digestion facility twice per CCS per nursery cycle.
Batch Dryer	Transport to composting facility	MCC	After drying, solids are stored on site before being transported via large transport truck to the nearest suitable composting facility twice per CCS per nursery cycle.
Batch dryer and incinerator	Transport to landfill	MCI-NC	After drying, the solids are incinerated in a shore-based incinerator with no heat recovery. The incinerator ash is stored on site before being transported via small truck and disposed of at the nearest landfill.
Batch dryer and incinerator with energy capture	Transport to landfill	MCI-WC	After drying, the solids are incinerated in a shore-based incinerator equipped with an energy capture system. The energy generated is used in place of diesel-generated electricity to operate the solids collection equipment. The incinerator ash is stored on site before being transported via small truck and disposed of at the nearest landfill.

5.6 Financial Analysis

For each of the combinations of waste capture, treatment and disposal considered above we have calculated a capital, operating and regulatory cost.

Capital Cost Analysis Methodology

The capital cost of each waste collection system included the purchase, installation and delivery costs. The purchase, installation and delivery cost estimates were obtained from the project commercial partners, quotes obtained directly from other supply companies or from product catalogues.

The capital cost parameters, representative values, ranges and sources can be found in Appendix Eleven.

The capital cost was depreciated over ten years using straight-line to zero depreciation, assuming £0 salvage value, further divided by 1.5 (the number of nursery cycles per year) and the number of post-smolts produced per cycle in order to allocate the depreciated capital cost to the total cost per post-smolt produced.

Operating Costs Methodology

The operating cost components of each waste collection system included the electricity, fuel, labour, maintenance and material removal and/or disposal costs.

The power required for pumping was calculated using the equation:

$$\text{Pump power (kW)} = \frac{(\text{Head loss} + \text{Friction Loss}) \times \text{WF} \times g \times \rho}{\text{pump efficiency} \times 1000}$$

..where WF is waste flow in m³/s and friction losses in the pipes were calculated using the Hazen-Williams equation, assuming a smooth PVC pipe, in the method described by Metcalf & Eddy, 2004. The contribution of fittings to friction loss were investigated, but deemed to be insignificant.

The electricity required for each component was calculated using the equation:

$$\text{Electricity (kWh)} = \text{component operating time} \times \text{component power requirements}$$

Waste disposal options and travel distances and distances to existing AD facilities have been calculated using SEPA's waste sites and capacity data tools (SEPA 2015c) and NNFCC's Biogas Map (2018). Potential disposal sites in Scotland are shown in Appendix eight. Distances from representative production sites near Ayr, Loch Ewe, Lewis, Lerwick and Fort William have been calculated using Google Maps.

The total operating cost was then divided by the number of post-smolts produced to give the operating cost per post-smolt produced (at mean weight of 1,000 ± 75g).

Regulatory Costs Methodology

The regulatory requirements (one-time applications and yearly costs), monitoring requirements and ease of implementation in Scotland of each solids handling and disposal system were determined by a review of current regulatory frameworks and publications and consultation with the Scottish Environmental Protection Agency (SEPA) and Scottish Animal Health (SAH).

The cost of recurring permit and licence fees were obtained from SEPA's Environmental Regulation (Scotland) Charging Scheme (SEPA 2018c) and by consultation with SEPA (Fiona Donaldson & Douglas Sinclair (SEPA) Pers Comm). The cost of meeting statutory monitoring and testing requirements was determined from Hutton Soils (2018) and consultation with SEPA.

The regulatory costs were treated in the same way as the capital and operating costs in that the one-off costs were amortised over 10 years and the annual costs plus the annual amortised costs were divided by the number of post-smolts produced per year to give a total regulatory cost per post-smolt.

Derived Costs – Capital Costs

The capital cost of solid waste capture, treatment and disposal for the various options, expressed as £/Post-Smolt produced (Capital costs depreciated with straight line to zero over 10 years) is shown in Figure 5.3.

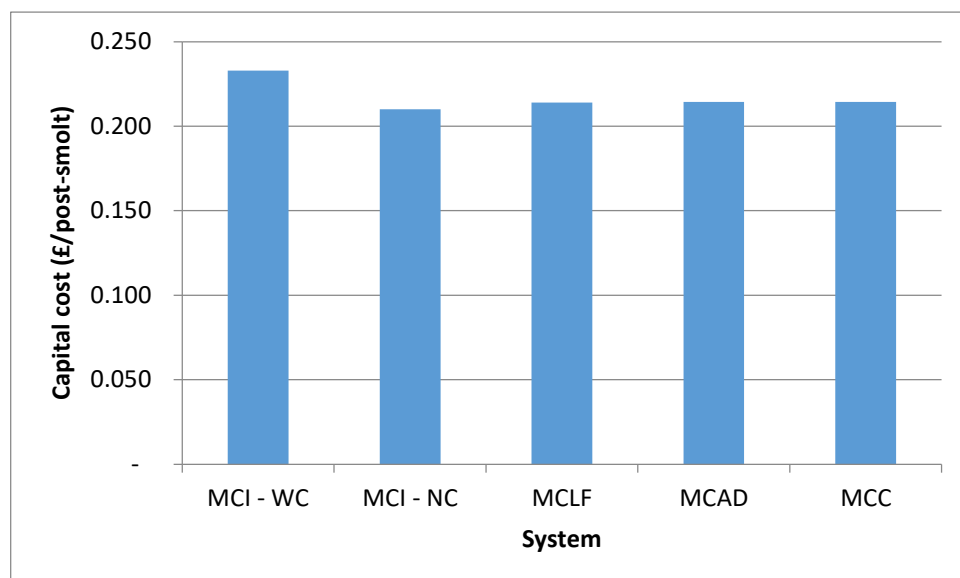

Figure 5-3. The capital cost of solid waste capture, treatment and disposal for the various system options expressed as £/Post-Smolt produced.

NB:

MCI-WC	Maximum waste capture, incineration on-site, with energy recovery
MCI-NC	Maximum waste capture, incineration on-site, no energy recovery
MCLF	Maximum waste capture, landfill
MCAD	Maximum waste capture, transport to anaerobic digestion
MCC	Maximum waste capture, transport to composting facility

Derived Costs – Operating Costs

The operating costs of solid waste capture, treatment and disposal for the various options, expressed as £/Post-Smolt produced are shown in Figure 5.4.

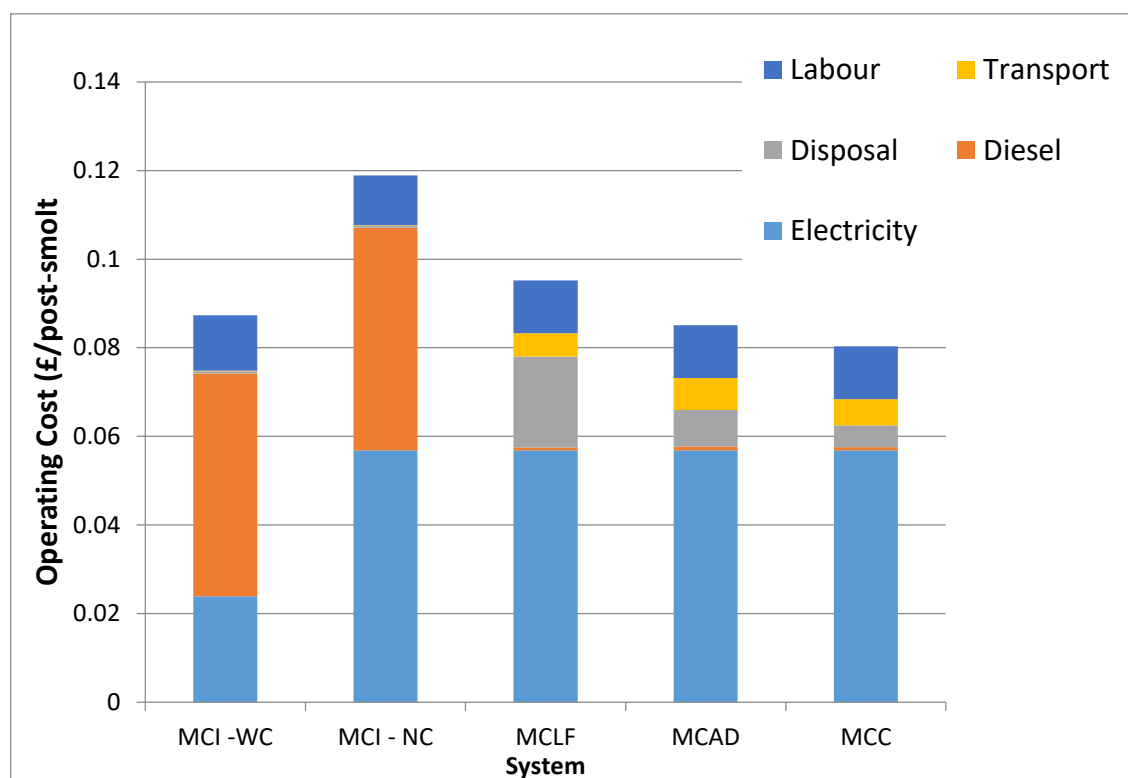

Figure 5-4. The operating cost of solid waste capture, treatment and disposal for the various system options expressed as £/Post-Smolt produced.

Derived Costs – Regulatory Costs

The regulatory cost of solid waste capture, treatment and disposal for the various options, expressed as £/Post-Smolt produced (one-off costs amortised over 10 years, annual costs treated as annual operating) is shown in Figure 5.5.

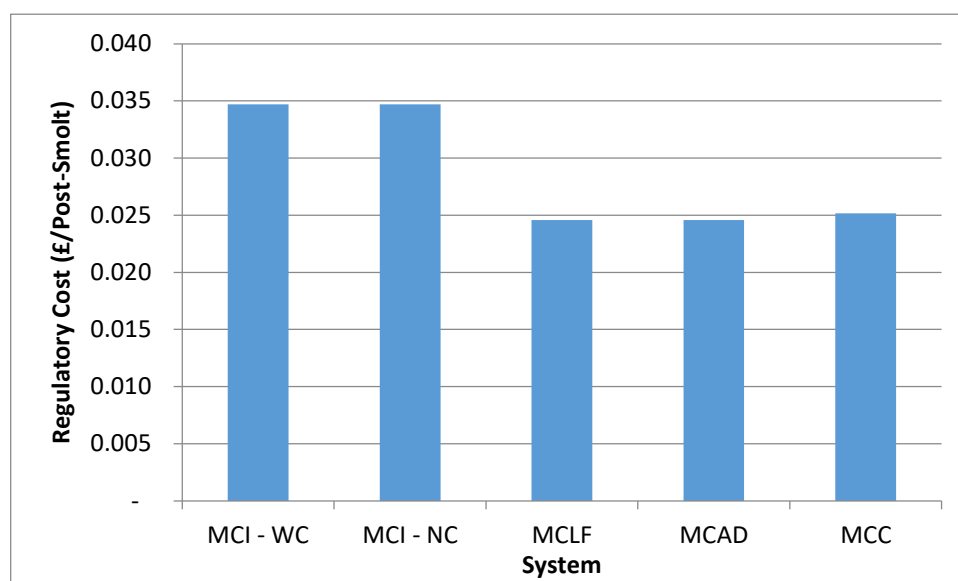

Figure 5-5. The regulatory cost of solid waste capture, treatment and disposal for the various system options expressed as £/Post-Smolt produced.

Derived Costs – Total Costs

The total cost of solid waste capture, treatment and disposal for the various system options from a single 6,000 m³ CCS, expressed as £/Post-smolt produced is shown in Figure 5.6 and Table 5-5 below:

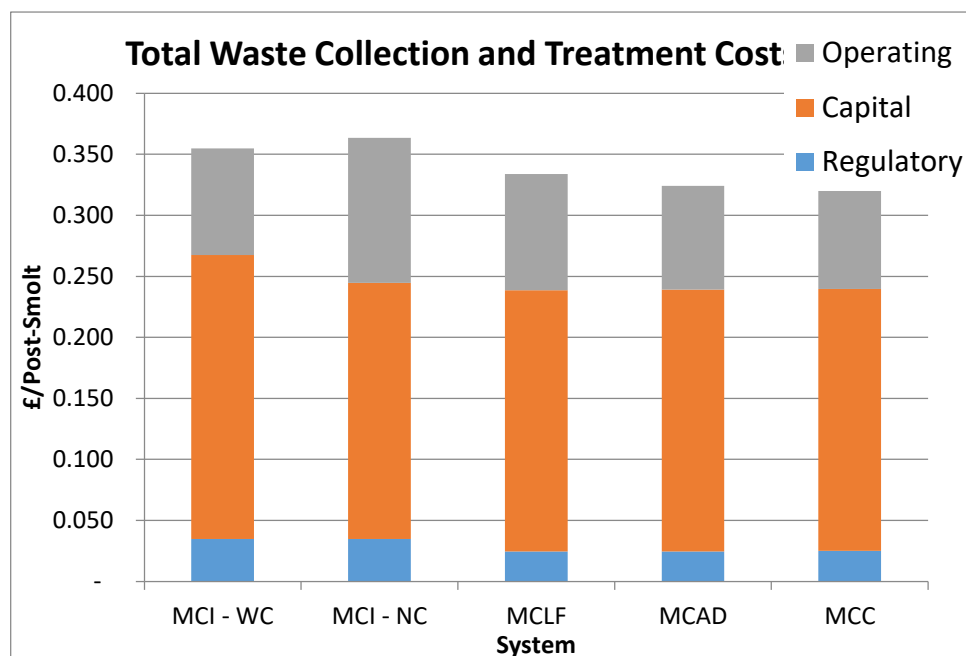

Figure 5-6. The total cost of solid waste capture, treatment and disposal for the various system options expressed as £/Post-Smolt produced.

Table 5-5. The total cost of solid waste capture, treatment and disposal for the various system options expressed as £/Post-Smolt produced.

System	Costs per post-smolt			
	Regulatory	Capital	Operating	Total
Maximum waste capture, incineration on-site, with energy recovery	£0.03	£0.23	£0.09	£0.35
Maximum waste capture, incineration on-site, no energy recovery	£0.03	£0.21	£0.12	£0.36
Maximum waste capture, landfill	£0.02	£0.21	£0.10	£0.33
Maximum waste capture, transport to anaerobic digestion	£0.02	£0.21	£0.09	£0.32
Maximum waste capture, transport to composting facility	£0.03	£0.21	£0.08	£0.32

6 Potential deployment strategies for floating CCS nurseries in the Scottish industry

6.1 Preamble

The purpose of this section is:

- to consider and define the current practices and trends at licensed seawater sites in Scotland
- to explain and quantify how the establishment and use of CCS nurseries offers the potential to increase output from the existing licensed sites.

6.2 Current stocking and deployment practices

Site stocking and deployment practices are determined both by regulation and by operators' strategic objectives for production scheduling and resource use.

6.2.1 Legislative constraints

Marine fish farm sites are operated under Licences issued by SEPA under the Water Environment (Controlled Activities) (Scotland) Regulations 2011. Licences set out the conditions regarding the interaction of the farm with the environment. Amongst these conditions is a definition of the maximum biomass permitted on site, usually referred to as the Maximum Allowable Biomass ("MAB").

The MAB for a site is defined by SEPA based upon analysis using the "Auto Depomod" analytical modelling tool which takes account of the environmental and physical conditions at the site. The various software tools and sampling and analytical procedures used by SEPA are summarised on SEPA's website <https://www.sepa.org.uk/environment/water/aquaculture/modelling/>. At the time of writing, there is also a convention that the highest MAB allowed at any site in Scotland is fixed at 2,500t. However, an aquaculture sector review by SEPA is anticipated for the end of 2018 and it is possible that the software tools and their application may change as a result of that review.

The stocking regimes at marine sites are further regulated with respect to fallowing, allowable rates of application of pharmaceutical agents, disease management areas and area management agreements.

A fallow period follows the complete harvest of a site during which all equipment can be removed and cleaned. This provides a period of relief from discharges to the water column and benthos and is intended to break any cycle of disease. The minimum length of fallow period recommended by SEPA is 6 weeks as this is considered to be the minimum time required to break the cycle of infestation and prevent reinfection by sea lice (SEPA 2016). Although not a statutory requirement of a licence, a minimum 4 week fallow period is a requirement of the Scottish Salmon Producers Organisation Code of Good Practice (SSPO 2015).

The Final Report on Infectious Salmon Anaemia in Scotland (Scottish Executive 2000) recommends a minimum of six weeks of fallow for all farms, three months of fallow for uninfected farms if there is suspected or confirmed ISA in the area, and six months of fallow for confirmed infected farms or those under suspicion. Farms within the same management area must synchronise their fallows (i.e. the whole management zone must be empty for three months beginning as soon as the last farm has been disinfected) if there is suspected ISA in the area (Scottish Government 2000, Scottish Executive 2000).

Management Areas are defined by Marine Scotland and are used for the control of outbreaks of notifiable fish diseases in the marine environment. Area management agreements between site operators within a management area are used to synchronise stocking, fallow and treatment to increase the efficacy of treatment and decrease the rate of lice infestations (Lees et al, 2009).

When one company holds all the licences within one disease management area or is the only aquaculture company involved in an area management agreement, synchronising fallow and treatment periods is relatively straightforward. Complex and detailed negotiations are needed however, when more than one company is operating sites within an area and issues with poor cooperation have resulted in law suits (pers. comm. Crown Estate Scotland).

An inevitable consequence of the fallowing requirement is a need to stock a single year cohort on a site. Whilst not mandatory, this is a recommendation of the SSPO Code of Good Practice (SSPO 2016) "multi-year class farming should only be undertaken following a satisfactory outcome from a documented risk assessment".

6.2.2 Strategic management of stocking and deployment practices

The strategic management of stocking and harvesting of a marine site is a complex affair, influenced by a variety of considerations, the dominant of which are seed fish availability, optimal timing for growth and market requirements for the fish produced. In Scotland, another major determinant of production regimes is the fact that over 95% of production is attributable to just 5 companies (see section1). The fact that a small number of companies each operate a large number of sites means that they are able to take a national, or even international view of harvesting policies in order to best serve their customer needs in terms of quantities, timing and fish size and to co-ordinate the supply of seed fish – from their own hatcheries in most cases - to deliver the desired production schedule.

The "seed fish" of salmon farms have typically been smolts (though the object of this study revolves around the premise that on-growing sites could be stocked with post-smolts from a nursery facility). Smolts are referred to by different class labels based upon the amount of time they have spent in freshwater, and whether they are transferred to sea 'in-season' (January to June - when wild salmon would naturally migrate to sea) or 'out-of-season' (July-December) (Ellis et al 2016):

- S $\frac{1}{2}$ (aka S0) smolts are transferred into sea cages between July and December and are <12 months old when deployed,
- S1 smolts are 12-18 months old at transfer and are deployed between January and June,
- S1 $\frac{1}{2}$ smolts are 19-24 months old at transfer and are deployed between July and December,
- S2 smolts are >24months old at transfer and are deployed between January and June.

S1 $\frac{1}{2}$ and S2 smolts have not been deployed in significant numbers (>1% of deployments) since 2006 and 1995 respectively (Ellis et al 2016; Scottish Government 2017).

The production of S½ smolts began in the early 1990s and they have represented an increasing percentage of smolts deployed since then. The number of S½ smolts deployed overtook the number of S1 smolts deployed in 2015, and 58% of smolts deployed in 2016 were S½ smolts (compared to 42% S1 smolts) (Ellis et al 2016; Scottish Government 2017).

There is an increasing trend towards vertical integration by salmon production companies and the last 10 years have seen substantial investments by the dominant companies in Scotland in large scale hatcheries which make use of recirculation technology (“RAS”), allowing for maximum control over environmental conditions and the optimisation of production parameters. As a result of the increased flexibility and control associated with RAS smolt production and the availability of ‘out-of-season’ eggs, smolts suitable for sea-deployment can now be made available year-round, instead of late Q4/early Q1 when they were typically deployed in the early days of the industry in Scotland (Ellis et al 2016; Jeffery et al, 2015 Lees et al 2009).

Smolt Size at Deployment

In the early days of the development of salmon farming technology, smolts were typically in the 30g – 50g size range at deployment, but thanks to improved husbandry practices, genetics and nutrition and optimized growth conditions (including in RAS hatcheries) the average size of deployed smolts has increased over the years to between 70 and 120 g (Ellis et al 2016).

Iversen et al (2016) have reported the increase in size at stocking of smolts in Scotland as shown in Figure 6.1 below:

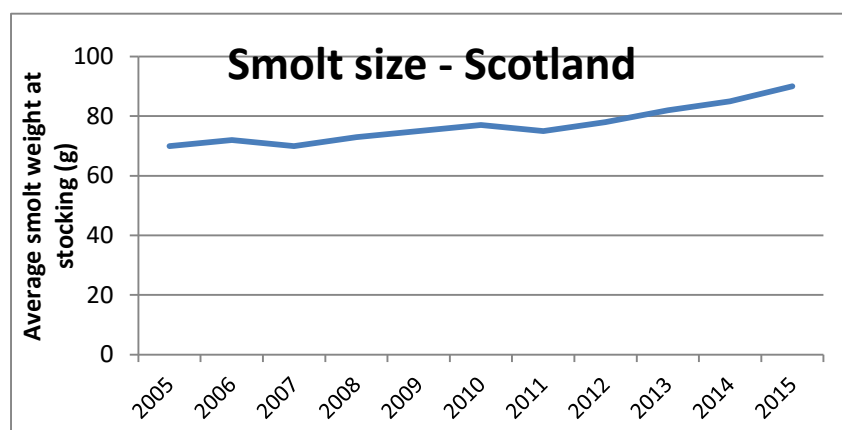

Figure 6-1. Trend in smolt size at stocking in Scotland (From Iversen et al 2016)

The deployment of larger smolts allows for earlier harvests, or the harvest of larger fish, and larger smolts are thought to be more robust and resistant to disease (Ellis et al 2016) although there is some contradictory evidence. It has also been reported that smaller smolts (100g) may have better growth rates than larger (600g) smolts (i.e. grow to the same harvest size same given the same amount time) (Mereghetti 2018, Gonzalez 2018).

With the recent increased use of RAS hatcheries, there is an emerging trend to delay smoltification or to continue to rear post-smolts in seawater RAS systems after smoltification to produce seed fish for ongrowing in the 250g – 500g range, in an attempt to shorten the sea-phase production period and minimize the number of medicinal treatments required (e.g. for sea lice). It is unclear where Iversen et al (2016) obtained their data on Scottish smolt size, but anecdotal evidence based on direct

observation (C Hyde pers comm) suggests that large smolts of ~400g have been routinely used for the past 2 years by some of the major producers and this doesn't seem to be reflected in the data of Iversen et al (2016) (Figure 6-1 above).

Timing of deployment

The growth of salmonids in the sea is heavily dependent upon the sea temperature, so the timing of deployment into the sea will have a considerable influence over the growth rate at various times in the growth cycle. Using the EWOS growth model set to geographical parameters specifically selected for this project (see Appendix Seven), we have plotted growth curves for 100g smolts stocked into sea pens on 1st January (Q1), 1st April (Q2), 1st July (Q3) and 1st October (Q4) using the same site conditions (Figure 6.2). The difference in individual body mass achieved is greatest around the body mass range at which fish are typically harvested (3 – 6kg).

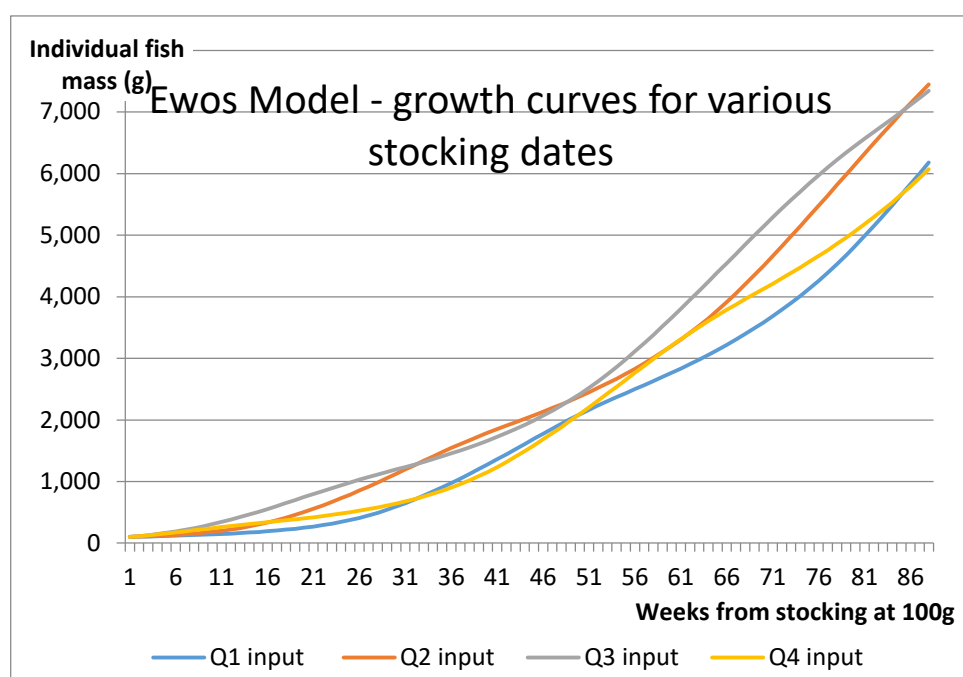

Figure 6-2. Growth curves for fish stocked at 100g at quarter 1 to Quarter 4 predicted from EWOS Growth Model set as described in Appendix 6

It can be seen that a Q3 input 100g smolt has reached > 5 kg after 68 weeks, whereas a Q1-stocked smolt is only 3.3 kg after the same time in the sea.

6.3 Current deployment regimes in Scotland

6.3.1 Salmon data analysis

A conventional deployment timetable typically involves stocking S1 smolts in Q4 of an odd year (or S1½ smolts in Q1 of an even year), and harvesting the fish in the summer/autumn of their second year (odd year Q3-Q4). After harvest, the site is fallowed for several months, until the next Q4/Q1 deployment (Lees 2009). Typically, this allows a regular 2-year cycle including a 2 month fallow period. An example of a biomass cycle at a representative, large (2,500t MAB) Scottish site is plotted below, using data from the Scotland's Aquaculture website.

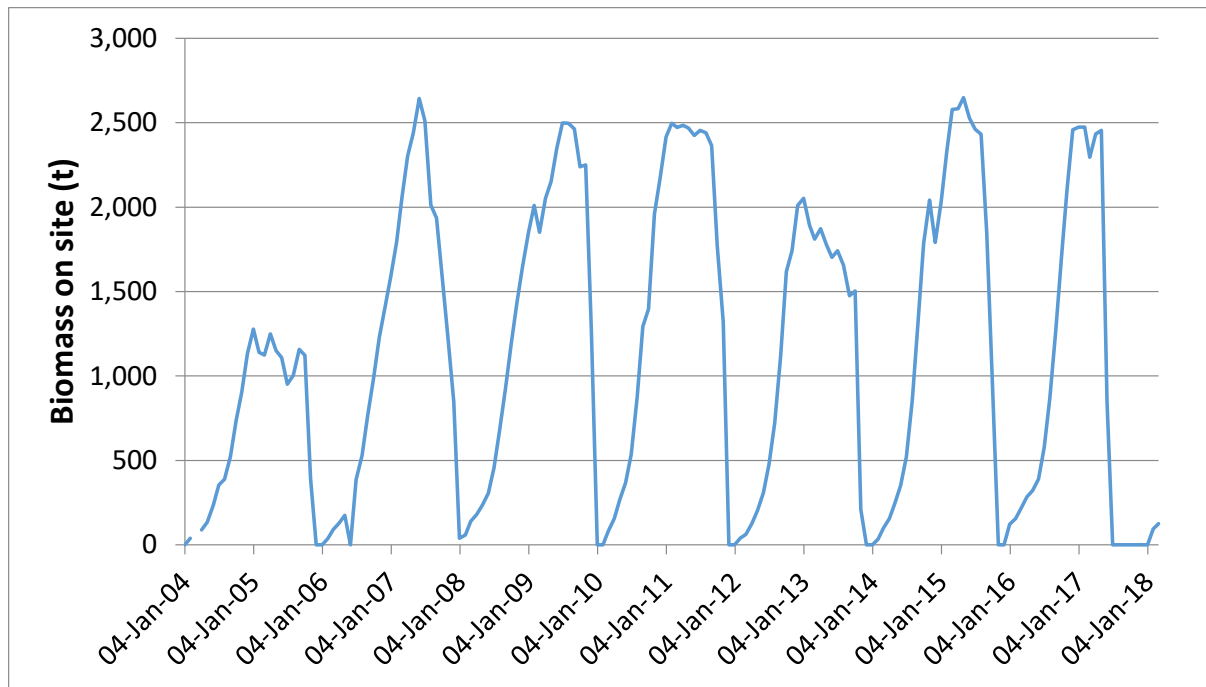

Figure 6-3. The stocking and harvest routine at a large Scottish site, represented by biomass on site (plotted from data on Scotland’s Aquaculture website).

Figure 6-3 shows 7 production cycles at a typical Scottish site (2500 tonne maximum biomass) going back to 2004. The site was stocked between January and March on even years, operated for 19-23 months, harvested-out to zero between July and December and fallowed for between 1 and 7 months (average of 2.5 months). This production cycle has been broadly followed at other 2,500 tonne MAB sites in the past few years (top Figure 6.4 below), whereas other sites are operated in the same way but “out of phase” (lower Figure 6.5).

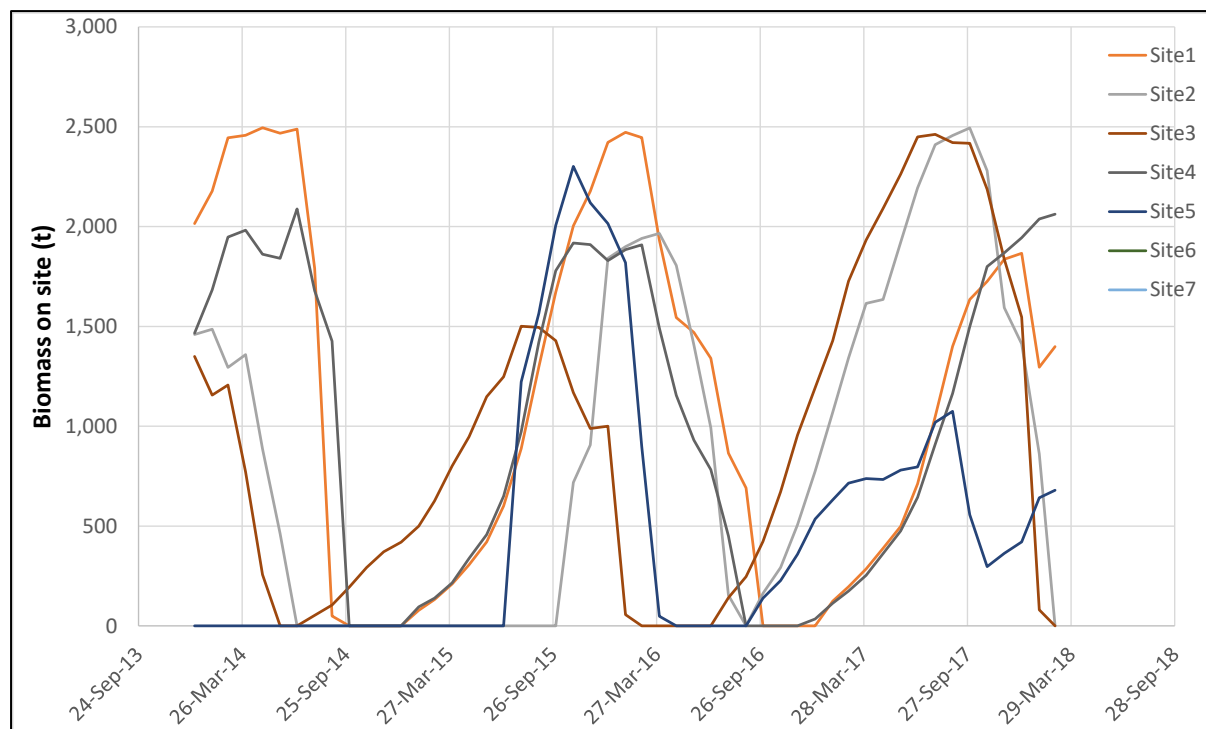

Figure 6-4. Biomass on site at selected sites (>2,000t MAB) from one of the major producers

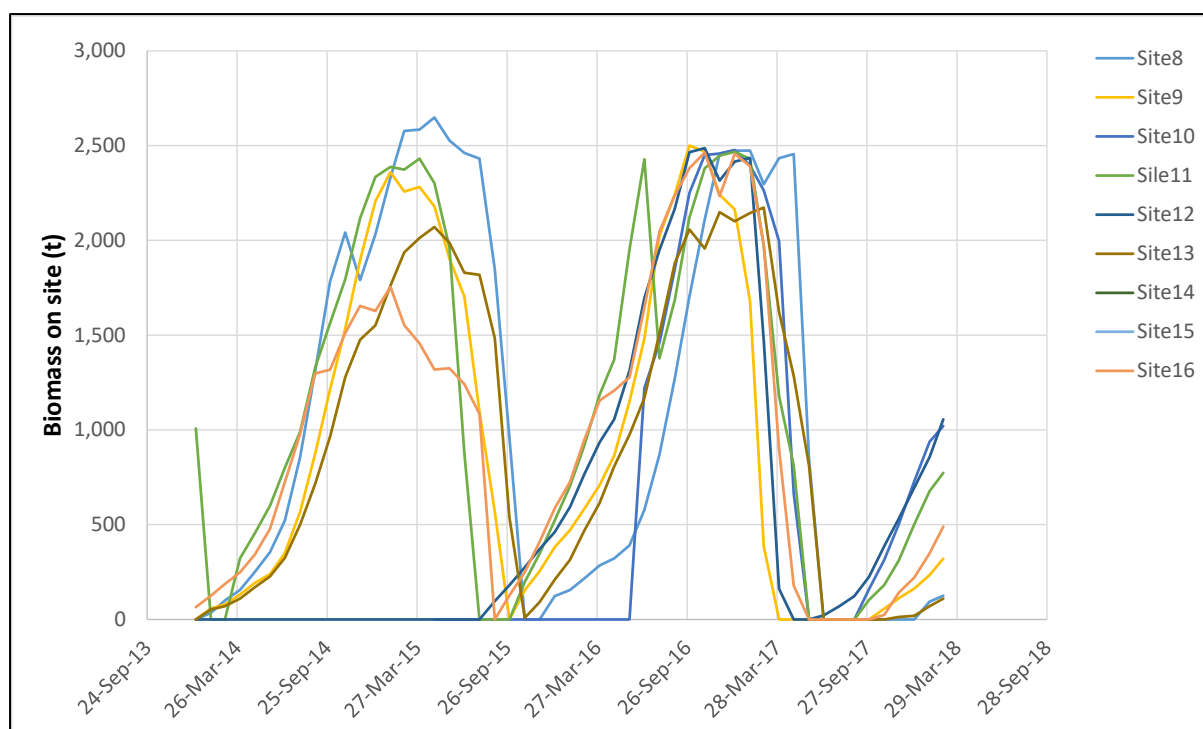

Figure 6-5. Biomass on site at remaining sites (>2,000t MAB) from one of the major producers showing “out of phase” production

We have analysed the biomass and treatment data published by the Scottish Government (http://aquaculture.scotland.gov.uk/data/fish_farms_monthly_biomass_and_treatment_reports.aspx) for all conventional sites with maximum biomass limits of $\geq 2,000$ tonnes and deduced that the average production cycle length is 20.1 (± 2.3) months long, with an average fallow length of 3.3 months.

6.3.2 Trout data analysis

The Scottish marine trout production sector is dominated by two companies – Kames Fish Farming and Dawnfresh, who operate 9 marine sites in total, though just 8 have been active since 2014. 4 sites are in Loch Etive.

The production strategies at sites outside of Loch Etive are similar in many respects to typical salmon production strategies. The Figure below shows that the stocking and harvesting regimes are fairly regular, though the duration of the cycles varies somewhat from site to site. It also appears that at some sites, fallow periods are not used, or they are very short compared with typical salmon sites.

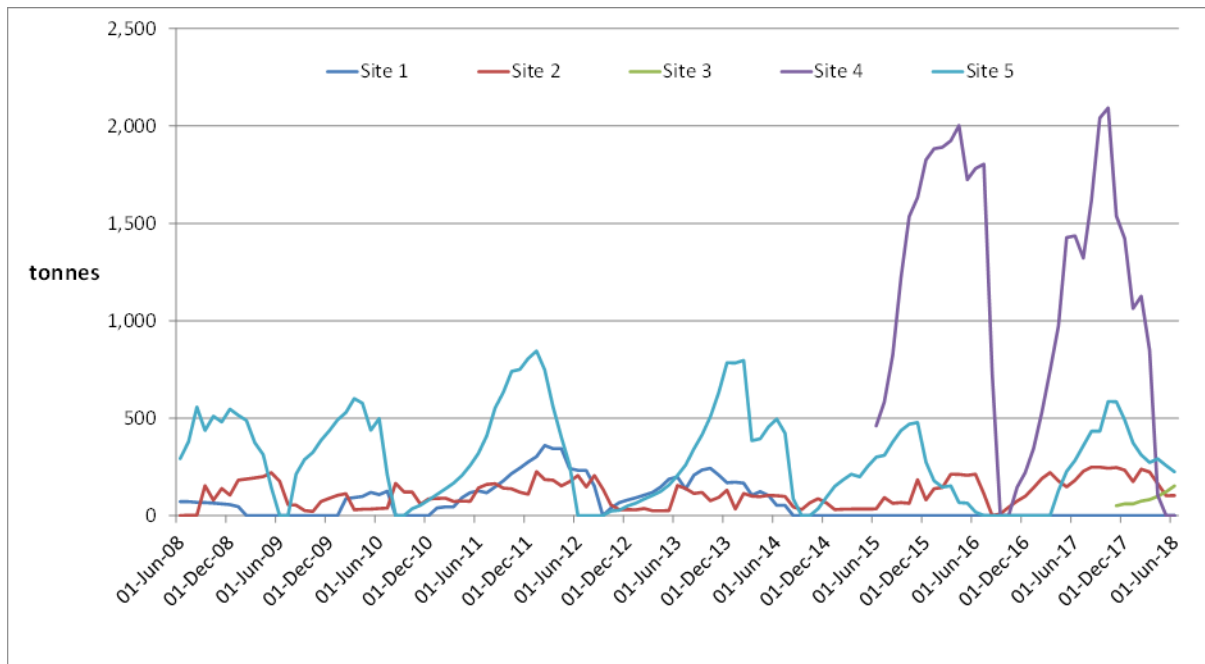

Figure 6-6. Production at Scottish marine trout sites excluding Loch Etive

By contrast, the production cycles at the Loch Etive sites are not operated on such a clearly regular basis. In fact, there is movement of fish between sites notably with (Inverawe) being used as a nursery to part-grow fish which are then transferred to other sites in order to maximise use of the maximum biomass allowance (Dawnfresh Production Director - pers comm...).

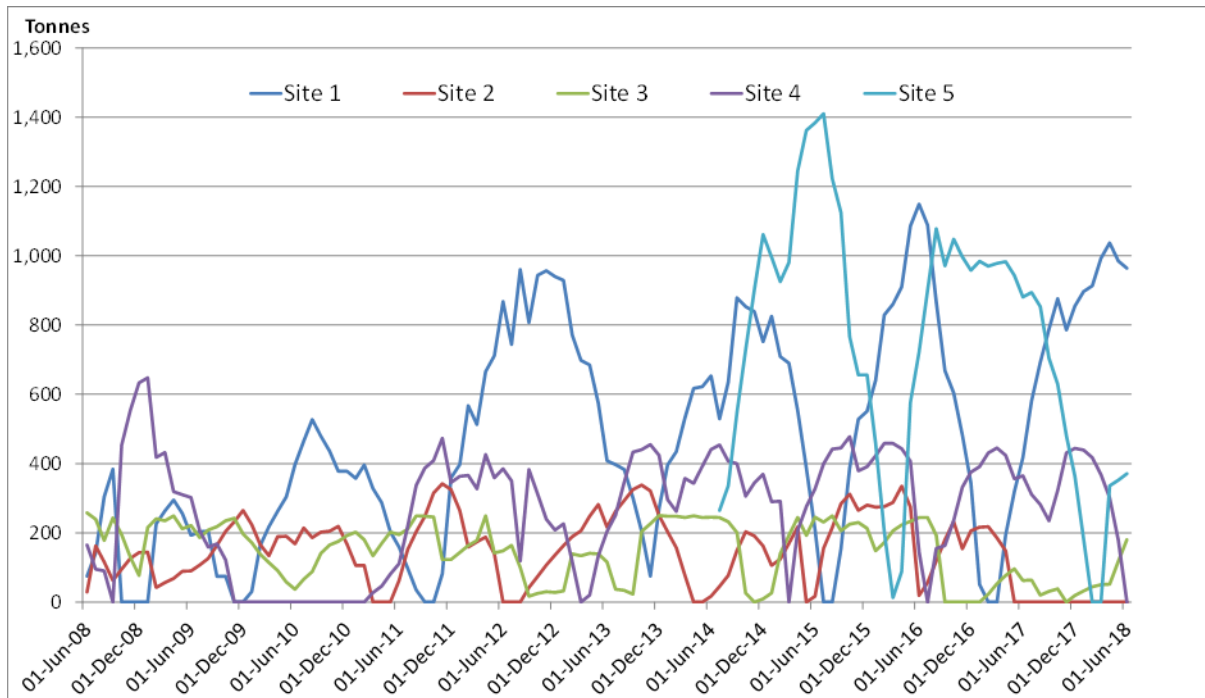

Figure 6-7. Marine trout production cycles at sites in Loch Etive

6.3.3 Stocking practices and the use of cages

The majority of Scottish salmon marine sites (182 sites in the last 3 years) use circular UHD-PE circular cages, with a minority (32 sites in the last 3 years) operating square or rectangular steel cages. The table below (Table 6-1) summarises cage equipment deployed in Scotland in the last 3 years.

Table 6-1. Equipment specifications on Scottish marine sites (from analysis of data from Scotland's Aquaculture website)

Cage Description	Average number of cages per site	As % of all sites
Circular – 70m circumference	11	3.7
Circular – 80m circumference	11	20.3
Circular – 90m circumference	10	17.5
Circular – 100m circumference	12	30.9
Circular – 120m circumference	11	11.1
Circular – 130m circumference	8	0.5
Square - 12mx12m to 24mx24m	23	14.7
Other	28	1.4

Source: http://aquaculture.scotland.gov.uk/data/site_facilities.aspx.

It can be seen that the typical on-growing site (80%) has between 10 and 12, 80 – 120 m circumference circular cages. Upon delivery of smolts to the sea sites, the normal procedure is to stock half the cages, then the fish are graded out into all the cages 6-10 months later as the larger fish approach the minimum size for harvest. There then follows a period of harvest lasting 8-10 months and the production cycle ends 16-24 months after sea deployment (Marine Harvest Handbook 2018; Ellis et al 2016). After harvest, the site is left empty (fallow) for between 4 weeks and 9 months, before the sea cage is supplied with a new batch of smolts.

6.4 Optimisation of current on-growing sites for improved use of MAB

6.4.1 The theoretical optimisation of the salmon grow-out production curve

From first principles it is possible to define the shape of an idealised production curve for a site if maximum use of biomass capacity is the strategic objective; it should have the steepest-possible up-slope – representing the shortest possible time for the stock biomass to increase such that the largest fish are of marketable size; this point should be as close as possible to the point where the maximum allowable biomass is reached; the “top-cropping” harvest should be regular and should match the increased weight of stock during the period – thereby maintaining the crop at maximum allowable biomass for as long as possible whilst feeding to the maximum level at which efficient feed conversion is achieved. Then, as soon as maximum allowable biomass can no longer be efficiently sustained (because harvest exceeds growth) the site should be harvested out as quickly as possible.

The optimised maximum production and actual production from a representative Scottish 2,500 MAB site are shown in Figure 6-8 below:

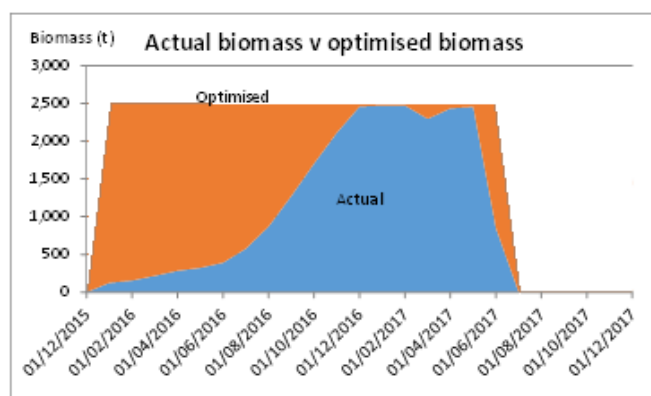

Figure 6-8. Actual biomass (blue) and Optimised use of a 2,500 MAB site

It can be seen that there is a substantial under-utilisation of the allowable biomass whilst the fish, stocked at ~100g individual mass, are growing in half the cages to reach the size when harvest can start. The efficiency of use could be improved by steepening the rate of increase of biomass. This could be achieved by stocking larger post smolts, as shown across two conventional cycles in Figure 6-9 below:

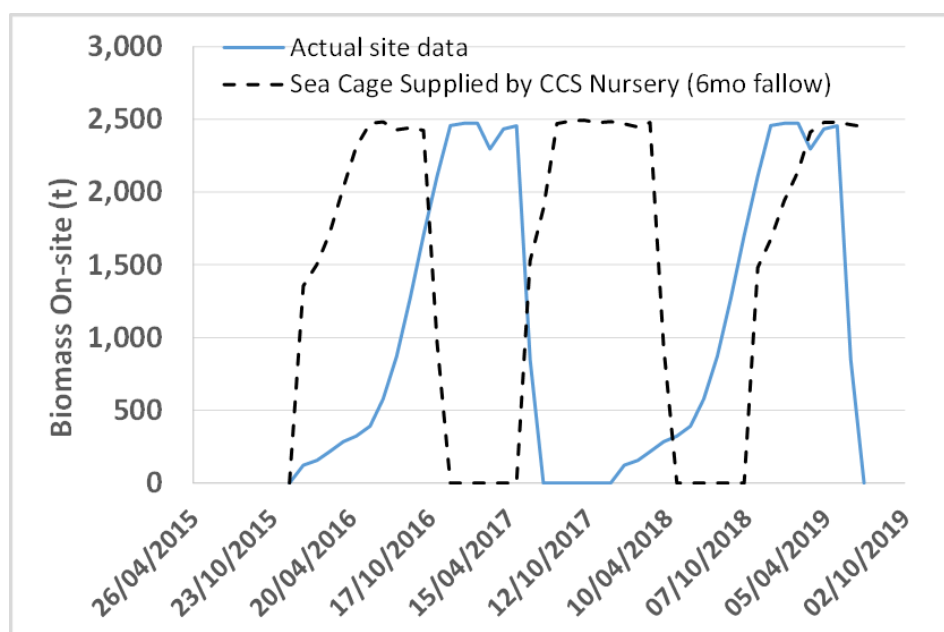

Figure 6-9. Comparison between use of conventional production cycle with stocking with 1,000g post-smolts – with 6 month fallow

The continuous line is the actual growth data projected over two cycles with a 6 month fallow period. The dotted line is the biomass profile when stocked with 1,000g post-smolts, harvested at a similar rate to achieve the same production per cycle and retaining a six-month fallow period. Note that whilst the two conventional cycles are symmetrical (because the cycle length is 24 months, so the smolts are introduced on the same date, two years apart), the theoretical curves calculated for the ex-nursery post-smolts have slightly different curve shapes, reflecting different stocking dates.

It can be seen that there is significantly greater use of the biomass potential with 1,000g post-smolts, with 2.5 complete cycles being completed in the time taken for 2 cycles with conventional stocking.

The length of the fallow period is also a potential factor in determining the efficiency of site use. With a production period of 18 months, the six months fallow may represent a convenient choice in order to maintain a regular two-yearly stocking pattern, rather than a necessity. As described in section 4, the minimum requirement regarded as necessary to break the sea lice cycle, assuming no other disease issue, is 6 weeks. The ability to use shorter production cycles will alter the strategy for fallowing and could allow for shorter fallow periods. In view of the reduced cycle time, it would also be anticipated that there would be less lice infestation than for conventional cycles so the actual need may also be reduced.

Figure 6-10 below shows the effect of stocking the same site as shown in Figure 6-9 stocked with 1,000g post-smolts, rather than 100g smolts, and reducing the fallow period to 4 months.

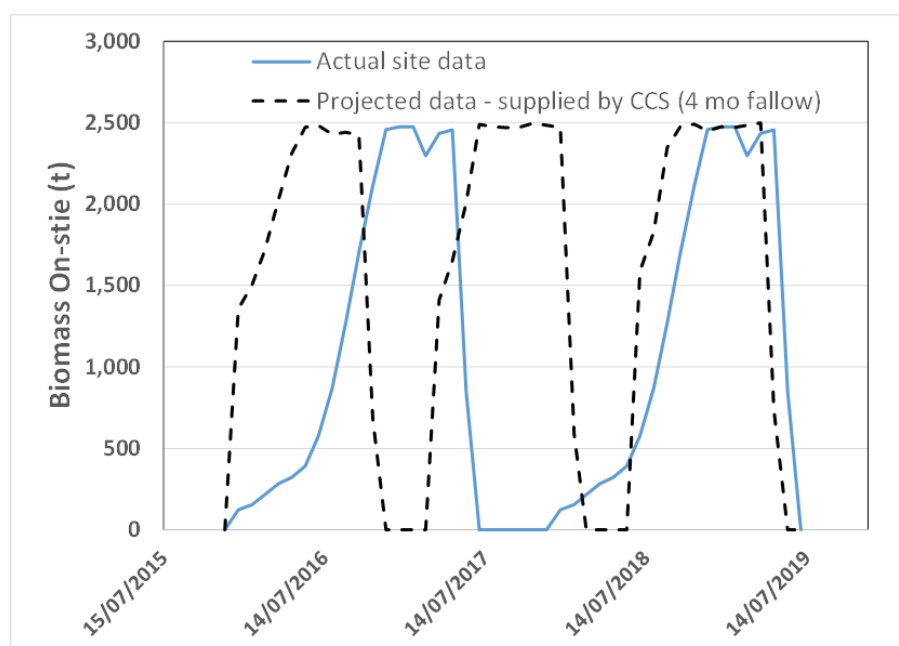

Figure 6-10. Comparison between use of conventional production cycle with stocking with 1,000g post-smolts – with 4 month fallow

It can be seen that with a 4 month fallow period it is possible to complete 3 production stocked with 1,000g post-smolts in slightly less than the time it takes to complete 2 cycles using conventional stocking of smolts at 100g, thereby increasing the production per period of time by over 50%.

This strategy requires a supply of 1,000g post smolts at the various start points – determined by the selected size of post-smolt and the chosen fallow period.

6.4.2 Applicability to marine trout production

Uniquely, because a) trout producers are not limited to single year cohorts on a site (either by SEPA licence conditions or as salmon producers are through the COGP) and b) they can move stock on a month-by-month basis between sites (they are not limited by the physiology of the smoltification process), there is a relatively smaller opportunity to utilise the nursery concept to increase the efficiency of use of biomass allowances on grow—out sites. However, other attributes of CCS such as

the ability to increase production with reduced effluent may stand further examination. This is considered further in section 8.

6.5 The potential use of nurseries to stock on-growing sites

6.5.1 Theoretical model

We have used the theoretical assumption that nursery cages are stocked with 100g smolts and grown to 1,000g. The harvest and system clean-out time between cycles would be about 2 weeks, following which the CCS nursery would be re-stocked with 100g smolts.

The time for growth of smolts from 100g to 1,000g would vary, depending upon the date of stocking of the smolts. We have used the EWOS model set to the project conditions (see Appendix seven) to calculate the growth period. Figure 6-11 below illustrates the variation:

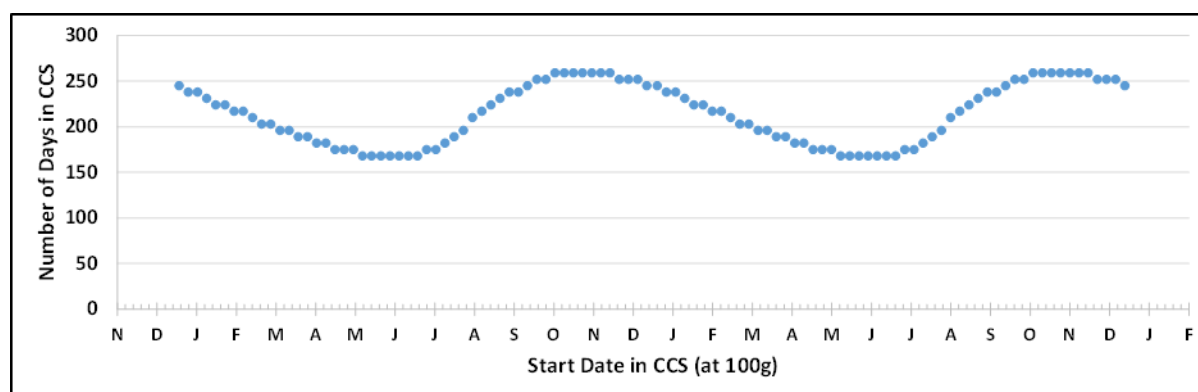

Figure 6-11. Impact of deployment date at 100g on the number of days required to reach ~1,000g in sea

In order to calculate the output from a CCS nursery we have run the EWOS growth model with the project parameters running consecutive cycles. By allowing 30 days between cycles for harvest, cleaning and disinfecting equipment and for any delays in availability of the next batch of smolts, we found that 3 cycles could be completed in precisely 2 years (Table 6-2).

Table 6-2. Cycle dates for 3 consecutive CCS cycles from 100g to 1,000g with 30 days between cycles.

Cycle	Year	Start Date	End Date	Number of days
Growth Cycle 1	1	April 1 st , 2019	Sept 30 th , 2019	182
Fallow 1	1	Oct 1 st , 2019	Oct 31 th , 2019	30
Growth Cycle 2	1	Nov 1 st , 2019	July 11 th , 2020	252
Fallow 2	2	July 12 th , 2020	Aug 10 th , 2020	30
Growth Cycle 3	2	Aug 11 th , 2020	March 1 st , 2021	203
Fallow 3	2	March 2 nd , 2021	March 31 st , 2021	30

The model predicts precisely 3 batches per 2 years or an average of 1.5 batches per year.

6.5.2 Model CCS system

For the purpose of modelling the potential application of CCS nursery sites being used to enhance the efficiency of use of grow-out sites in Scotland, we have based our calculations on a model 6,000m³ nursery unit with a maximum allowable stocking density of 15 kg/m³. If operated according to the model strategy described in 6.4.1 (above), each CCS unit would have a batch output of 90,000 post-smolts of 1,000g.

In order to evaluate the potential for the use of CCS nurseries to enable an increase in production from grow-out sites which are presently in use in Scotland we have made the simplifying assumption that typical sites are presently stocked with 100g smolts at various times of the year. We have analysed the monthly biomass returns (on Scotland's Aquaculture website) from all active sites having MABs of >1,999t for the last 10 years and calculated the average grow-out cycle length and the average length of fallow periods.

We have analysed the stocking cycles of all the sites in Scotland with maximum biomass consents > 1,999 kg and found that the average production cycle length is 20.1 (±2.3) months long, with an average fallow length of 3.3 months.

We have also calculated the total harvest per cycle from each site with a MAB >2,499t. We obtained a Figure of 1.72 (ie, ~4,300t harvested per cycle from a 2,500t MAB site). This is slightly lower than the average factor value (1.9) stated by Marine Harvest (2018); however, we have used the conservative value of 1.7.

Of course, an under-pinning assumption for the use of CCS to supply on-growing sites, thereby shortening the cycle length and increasing the rate of output from the on-growing site, is that 1,000g post-smolts will be available from the CCS nurseries throughout the year. Assuming that is the case, for the same site conditions (principally day length and sea temperature), full cycles will inevitably vary in length, depending upon the starting date. We have therefore based our analysis on production projected over 10 years, in order to even out the cycle-by-cycle differences.

We have compared the production over 10 years (including incomplete cycles as *pro rata*) of the average production cycle under *status quo* conditions (101.4 weeks) with the same conditions without the average time required for post-smolts to grow from 100g to 1,000g. As a further comparison, noting the reduced load on the environment from the shorter cycle, we have also made a comparison with the reduced cycle further modified to have only a 6 week fallow period.

The production from the existing site capacity under these conditions has been calculated for various degrees of uptake of the CCS post-smolt-based strategy from 0% (no uptake) to 100% uptake.

The results are as follows:

Table 6-3. Projected production for various levels of uptake of CCS-based strategy (6 months fallow)

	Sea Cages	CCS Nursery (6 months fallow)			
		10%	25%	50%	100%
% production supplied by CCS:	0%	10%	25%	50%	100%
Average per year production, from 10 year cycle (t)	174,076	179,879	188,583	203,089	232,102
% Increase	NA	3.33%	8.33%	16.67%	33.33%

Table 6-4. Projected production for various levels of uptake of CCS-based strategy (2 months fallow)

	Sea Cages	CCS Nursery (2 months fallow)			
% production supplied by CCS:	0%	10%	25%	50%	100%
Average per year production, from 10 year cycle (t)	174,076	186,511	205,162	236,247	298,417
% Increase	NA	7%	18%	36%	71%

We have calculated the number of 6,000m³ CCS units that would be required to achieve these increases in production as follows:

Table 6-5. CCS units and sites required for various levels of uptake of CCS-based strategy (6 months fallow)

	Sea Cages	CCS Nursery (6 months fallow)			
% production supplied by CCS:	0%	10%	25%	50%	100%
Average per year production, from 10 year cycle (t)	174,076	179,879	188,583	203,089	232,102
No of 80m circle CCS units needed:	0	27	67	134	268
No of nursery sites (10 units)	0	3	7	14	27
No of nursery sites (6 units)	0	5	12	23	45

Table 6-6. CCS units and sites required for various levels of uptake of CCS-based strategy (2 months fallow)

	Sea Cages	CCS Nursery (2 months fallow)			
% production supplied by CCS:	0%	10%	25%	50%	100%
Average per year production, from 10 year cycle (t)	174,076.60	186,511	205,162	236,247	298,417
No of 80m circle CCS units needed:	0	34	86	172	344
No of nursery sites (10 units)	0	4	9	18	35
No of nursery sites (6 units)	0	6	15	29	58

7 Financial analysis

7.1 Preamble

We have defined a model of a CCS nursery to investigate technical and financial aspects of the use of floating CCSs to increase production from existing marine aquaculture sites.

We have assumed the maximum stocking density of a marine CCS under current guidelines will be limited to 15 kg/m³, the current RSPCA welfare standard requirement for seawater cage sites (RSPCA 2018). We have selected a system volume of 6,000 m³ for a single unit as this is a typical size of systems under development (see section 3). The output from a single cohort of average 1kg fish if the system were operated to the maximum usage within the stocking density constraint would be 9,000 post-smolts.

A site with six of the model units would have an output per cycle of 54,000 post-smolts which is approximately the number required to stock a 1,500t MAB site (based upon a production to MAB ratio of 1.7 – see section 6) and a harvest weight of 4.5 – 5kg and a 10-unit site would stock a 2,500 MAB site.

7.2 Cost analysis

Wherever possible we have calculated values for additional capital and operating costs. If useful cost data was not available we have estimated values.

The additional operating costs for production of post-smolts in floating CCS include:

- Energy costs to pump water through the CCS
- Costs for collecting, treating and disposing of solid waste
- Extra labour to manage the CCS plant and equipment
- An extra transport step to transfer post-smolts to the ongrowing site

We have also calculated the net capital costs of various CCS and expressed the depreciated values of the capital costs as equivalent to additional production costs.

7.2.1 Energy costs for pumping

We have calculated the flow requirements on the basis that all the oxygen needs are supplied by the incoming water. Daily oxygen consumption was calculated from feeding rate using the multiplier determined experimentally by Thorarensen and Farrell (2011) who determined a range of oxygen:feed consumption ratios of 0.25 – 0.45. As a conservative estimate we have used the higher value of oxygen consumption rate = 0.45 x feed rate. The allowable minimum value of dissolved oxygen was set at 60% of the saturated value at each day's temperature on that basis that this has been defined as the lower limit of the optimal oxygen level for growth and feeding behaviour for salmon in cages by Stehfast et al (2017). We have then built in a safety factor of +50% to the flow requirement.

The growth model (see Appendix 6) set to the appropriate project parameters, was used to calculate daily feeding rates, based upon fish size and water temperature and by setting various start dates for model CCS production cycles, oxygen consumption rates and hence water flow rates were calculated as daily values for each cycle as shown in Figure 7.1 below:

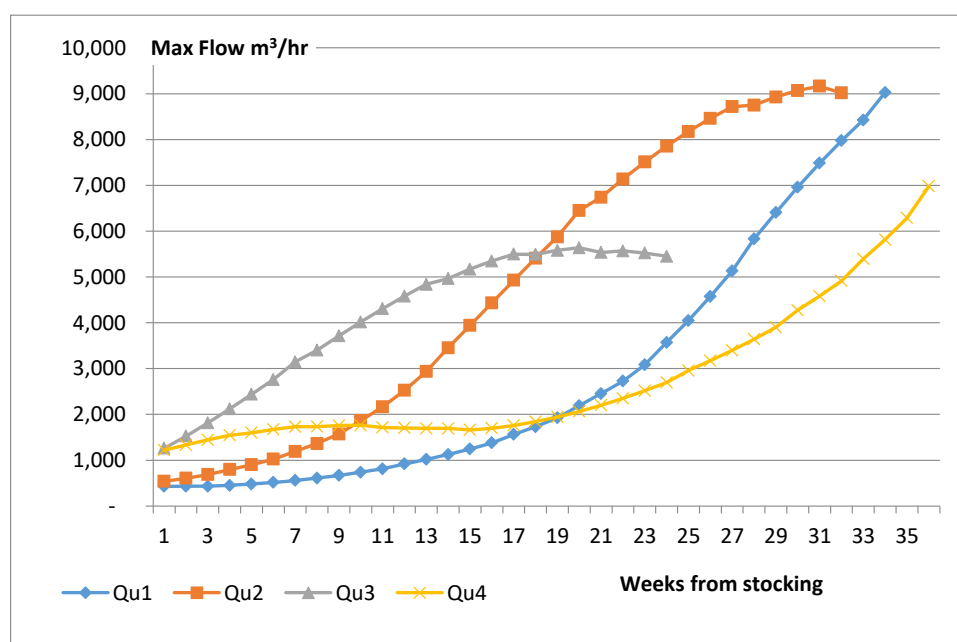

Figure 7-1. Maximum flow rates through cycles stocked by Quarters 1 – 4

Pump power and energy for the water supply were calculated using the following equations:

$$\text{Pump power (kW)} = \frac{(\text{Hydrostatic head} + \text{Friction Loss}) \times Q \times g \times \rho}{\text{pump efficiency} \times 1,000} \quad \text{and}$$

$$\text{Pump Energy (kWh)} = \text{pump operating time} \times \text{pump power requirements}$$

Where Q is water flow in m³/s and ρ is the density of seawater. A pump efficiency of 65% was assumed (probably conservative).

The total head (hydrostatic head + friction loss) will be determined on a case-by-case basis from a specific system design but for the model it was assumed to be constant at 1.5 m. Friction losses in the intake pipes were calculated using the Hazen-Williams equation, assuming a smooth 35m PVC pipe, in the method described by Metcalf & Eddy (2004), and for an 18" (450mm) pipe with a flow of 0.6m³/s was found to be <0.6m and if the pipe size was increased to 600mm the head loss was 0.15m.

The cost of energy was assumed to be £0.4 per kW hr based on supply from a diesel generator. Weekly costs were calculated for each week in each cycle and summed to give the pumping cost per cycle.

The energy cost for pumping water per cycle was as follows:

Table 7-1. Energy costs for water supply per CCS nursery cycle

	Energy cost for water supply per cycle	Energy cost per Post-Smolt
Qu1 stocking	£42,062	£0.47
Qu 2 stocking	£34,911	£0.39
Qu 3 stocking	£32,453	£0.36
Qu 4 stocking	£42,816	£0.48
Average	£38,061	£0.42

Costs for collection, treatment and disposal of waste were calculated in section 5.6. In summary, they were (expressed per post-smolt produced):

Table 7-2. Costs for waste capture, treatment and disposal from the CCS

System	Costs per post-smolt			
	Regulatory	Capital	Operating	Total
Maximum waste capture, incineration on-site, with energy recovery	£0.03	£0.23	£0.09	£0.35
Maximum waste capture, incineration on-site, no energy recovery	£0.03	£0.21	£0.12	£0.36
Maximum waste capture, landfill	£0.02	£0.21	£0.10	£0.33
Maximum waste capture, transport to anaerobic digestion	£0.02	£0.21	£0.09	£0.32
Maximum waste capture, transport to composting facility	£0.03	£0.21	£0.08	£0.32

The total cost per post-smolt for the four viable options is £0.32 - £0.36, average £0.34 per post smolt produced. This can be broken down as £0.12 as average operating costs (including all regulatory costs) and £0.21 average capital costs.

Labour costs

Additional labour costs will be required for the maintenance and servicing of water pumps. Activities associated with waste collection and treatment were included in the costs in Table 7.2. For a site of 6 CCSs with 24 pumps, we estimate a need for 0.75 full-time equivalent engineers at an annual cost of £35,000.

With a post-smolt output of 1.5 cycles per year and 90,000 post-smolts per cycle this equates to £0.032 per post-smolt produced.

7.2.2 Additional transport costs

If a CCS nursery site is not co-located with either the hatchery supplying it or the on-growing site it supplies, there will be a need for additional well-boat transport of large (1kg) fish to on-growing sites.

Based upon the estimated cost of a single well boat transfer from Jeffery et al (2014) (stocking density of 37.5 kg/m³ in 1,000m³ well boat at a cost of £8,000 per journey), we have calculated the cost of well boat transfer as £0.21/kg/transfer.

ie, £0.213 per post-smolt/transfer.

7.2.3 Other operating costs

All other operating costs are considered to be the same as would be incurred in growing the fish from 100g smolts to 1kg in the conventional open pen system with the exception of the reduced lice treatment costs which are calculated in section 4.

The total additional operating costs are as follows:

Table 7-3. Total additional operating costs for CCS nursery system (compared with equivalent conventional system and operating methods)

Operating cost item	Additional cost per post-smolt
Pumping water into CCS	£0.42
Waste collection, treatment and disposal	£0.12
Additional labour	£0.03
Additional well boat	£0.21
Total Operating costs	£0.78

7.2.4 Capital costs

The capital costs for the waste collection, treatment and disposal systems were calculated above and expressed as £0.22 per post-smolt produced by allocating the annual depreciation amount to the number of post-smolts produced per year.

Capital costs for 5 system types have been calculated based on outline commercial quotations or estimates and re-calculated pro-rata for 6,000m³ capacity systems.

Table 7-4. Summary of the model systems

System	Detail	Total capital cost including additional shared services
1	Self-assembled, flexible Based on assembly of individual components sourced in Scotland. Bespoke fabric container sourced in India.	£529,136
2	GRP system complete Commercially-available system supplied by Aquafarm	£1,419,000
3	Flexible system complete Commercially-available system supplied by Botngaard	£975,000
4	Heavyweight concrete Based on concept design by Scottish supplier	£6,075,000
5	Lightweight concrete Based on concrete design by Scottish supplier	£1,297,500

For all systems, costs have included the container, floatation, controllable valve system, emergency oxygen system, 4 x axial water supply pumps all based on a single 6,000m³ system. A contribution has been added to each for a 1/6 share of additional mooring costs and additional generator capacity and

electrical distribution capacity on the basis that these would be added to central (barge) services for a system comprising 6 units.

In order to compare these prices a depreciation period has been estimated for the various components and an annual straight-line-to-zero depreciation cost has been calculated as follows:

Table 7-5. Depreciated capital costs of the model systems

	System	Detail	Annual depreciated costs
1	Self-assembled, flexible	Based on assembly of individual components sourced in Scotland. Bespoke fabric container sourced in India.	£105,827
2	GRP system complete	Commercially-available system supplied by Aquafarm	£82,200
3	Flexible system complete	Commercially-available system supplied by Botngaard	£195,000
4	Heavyweight concrete	Based on concept design by Scottish supplier	£328,200
5	Lightweight concrete	Based on concrete design by Scottish supplier	£114,330

Table 7-6. Depreciated capital costs of the model systems expressed per post-smolt produced

	System	Detail	Depreciation allocated as cost per post-smolt
1	Self-assembled, flexible	Based on assembly of individual components sourced in Scotland. Bespoke fabric container sourced in India.	£0.78
2	GRP system complete	Commercially-available system supplied by Aquafarm	£0.61
3	Flexible system complete	Commercially-available system supplied by Botngaard	£1.44
4	Heavyweight concrete	Based on concept design by Scottish supplier	£2.43
5	Lightweight concrete	Based on concrete design by Scottish supplier	£0.85

By taking the allocated depreciation cost of the lowest-cost commercially-available systems (Aquafarm) and adding the allocated depreciation cost of the waste capture and treatment system (£0.22) to the sum of the additional operating costs associated with CCS we derive a total of additional costs (compared with open pen) of producing a 1,000g post-smolt in CCS of £1.61.

8 Discussion

8.1 Logistical benefits

In our analysis in section 6 we have shown that the use of floating CCS as nurseries to supply existing on-growing sites will undoubtedly offer a means of increasing the production from those sites. Under conventional stocking and harvesting regimes the potential capacity of on-growing sites is limited by the necessity to stock single year classes and the length of the production cycle which is currently about 24 months. As a consequence, the stock at a typical site will only reach the maximum permitted biomass for about 3 months during a 24 month cycle. The use of nursery sites would allow larger post-smolts to be stocked, thereby reducing the overall production cycle length and increasing the relative proportion of the production cycle at which the biomass is close to the permitted maximum.

We have shown that it would be possible to increase the output from existing sites by up to a maximum of about 70% - this maximum being the theoretical situation where 100% of the stock for on-growing is produced by nurseries and where the average duration of fallow periods is reduced to 2 months.

In order to implement this revised stocking and harvesting strategy, a number of changes would need to be made to the *status quo*. First, and most obviously, sites would need to be identified in which to locate the nurseries and sites established. According to SEPA (2018b), 36% of licensed sites are currently un-used. It is likely that in many cases, sites are unused because they are simply not large enough – either physically or in terms of the potential maximum allowable biomass - to accommodate a conventional on-growing site of the size which is typical of the industry today and which consequently has the potential to be financially competitive. Although a survey of potential sites for CCS nurseries is beyond the scope of this project, we have carried out a superficial exercise to investigate the nature of 111 unused sites (see appendix 10). We have found that 42 (38%) of unused sites have a depth of over 20m [with 30% being > 25m] and as such, meet at least one criteria for suitability for the siting of CCSs.

Another important consideration in the potential use of nursery sites to supply growout sites is that the resulting extended portion of the production cycle at which the system is close to maximum allowable biomass may create environmental conditions associated with solid waste deposition and dispersal that are in excess of existing licensed conditions. The current model (DEPOMOD) used to define licence conditions for a site is based upon the scenario that the peak feed input is sustained for a three month period (SEPA, pers comm Nov 2018); although current licences might allow a longer period of maximum feeding, the potential for modification would need to be considered on a site-by-site basis. The draft aquaculture sector plan³ released by SEPA on 7th November 2018 suggests that the proposed revised regulatory regime will allow increased outputs in deeper, well-flushed sites, but this will not be the case in shallower slow-flowing sites. The revised modelling regime will consider sites on a case-by-case basis with advanced, evidence-based analysis and modelling (SEPA 2018b).

Of course, it is entirely possible to implement a production regime which includes a nursery stage without using CCS technology. Conventional cage technology could be used in new or existing licensed but unused (possibly smaller) sites to produce post-smolts for transfer to growout sites – thereby gaining the efficiency of site usage described above; indeed to some extent this practice is already used at trout sites in Loch Etive (see section 6). Similarly, the improved efficiency could also be achieved by using large smolts or post-smolts from land-based RAS hatcheries.

³ <http://media.sepa.org.uk/media-releases/2018/aquaculture-sector-plan/>

However, there are strong arguments against developing nursery sites based upon conventional technology from both the producers' and the regulators' points of view. From a producer's perspective, whilst the efficiency of use of an ongrowing site could be substantially increased by using a nursery site to supply larger post-smolts to the ongrowing site, in most cases this would also necessitate an additional transport process for the fish. Jeffery et al (2014) derived a cost for transport of 1,000g post-smolts by well boat at £0.21 each; furthermore, there is a risk that well-boats can act as vectors for the spread of infections or the water exchanged during the journey could bring in or spread infection along the route (Turnbull 2014). The combination of additional transport costs and increased health risks associated with the transport and transfer processes would mitigate strongly against this strategy (using conventional cage systems).

For the regulator (local authorities and SEPA) there is little incentive to support the use of nursery systems based upon conventional technology. Although there is increased efficiency of use of the existing ongrowing sites, the "cost" would be the development of the nursery sites and the associated environmental consequences. As noted above, a specific statement from SEPA's draft sector plan for aquaculture (SEPA 2018b) signals an intention to reduce or remove cage farms from sites which are either shallow, have poor flushing rates or both in favour of development in large, deep, well-flushed locations. Such sites could only be approved for new nursery developments provided the activity included substantive changes in operating practices which might reduce environmental impact such as the collection and disposal of waste through the use of CCSs. The draft plan specifically notes the anticipation that it will "encourage the adoption of new technologies such as partial and full containment to capture organic waste and any remaining medical residues."

8.2 Logistical Challenges

One of the key challenges to adopting a "floating CCS nursery" strategy will be the identification and development of appropriate nursery sites. As well as having adequate depth (see 8.1 above) sites would need to be very sheltered in order that the wind, wave and current forces on the containment system are minimised.

Also, the CCS system has a high power requirement, mainly for pumping, and ideally this would be obtained through a national grid; however, the availability of 3-phase capacity in rural locations of low population is very scarce in Scotland. However, this does raise the possibility that CCS nurseries could be located in more industrial landscapes than is typically the case for conventional cage systems.

It would also be beneficial if CCS nurseries could be sited very close to shore in order to reduce the challenge and costs of shipping batches of partially de-watered solid waste to a land base for final processing.

Perhaps the least attractive attribute of using CCS nurseries is the need for an additional transport step as discussed in 8.1. An ideal situation would be one where the CCS nursery could be co-located with the ongrowing site, but given the specific need of a CCS system for a combination of depth with significant shelter and low exposure to wind and currents it seems unlikely that many suitable locations for co-located CCS nurseries and ongrowing systems can be found.

8.3 Reduction in sea lice infestation and losses

We have shown in section 4 that the use of CCSs to produce post-smolts could reduce sea lice infestation and associated losses through the simple mechanism of abstracting water for the CCS from depths below which lice typically occur. Whilst there are, at the moment, only a few objective scientific studies to support this claim, there is a compelling body of anecdotal supporting evidence from reports of pilot studies in CCS systems as well as from the increasingly common use of lice skirts to reduce infestation losses.

We have analysed the frequency of use of various lice treatments at Scottish sites for the first 7 months of the marine phase of ongrowing in cages and we have extrapolated the potential cost of these treatments, based upon published data and analysis of costs. This analysis suggests that savings of up to £0.17 per kg of harvested fish could be achieved if there were no lice treatments used in the nursery CCS.

Whilst we go on to show that this potential cost saving from reduced lice treatment could partially justify the added costs that would be incurred by using CCS, the production companies will weigh this argument alongside their ongoing investments in other non-chemical means of lice treatment such as hydrolicing.

8.4 Reduction in solid waste released to the environment

The use of CCS technology offers a clear potential advantage over conventional floating systems in that the collection of 85% of settleable solid waste (68% of total solid waste) at the CCS nursery site will reduce the environmental impact of the nursery site. In the absence of widely-used established technology for use specifically in association with CCS, in section 5 we have proposed a physical model of a settling zone in the CCS from which a concentrated suspension of solids can be pumped, either continuously or intermittently (depending on loading) to a de-watering system comprising a rotating screen filter and a centrifuge which could be mounted on a floating deck alongside, or integrated with the CCS. This approach is broadly based upon similar systems used for sewage treatment on board cruise liners. The de-watered sludge can be transported or pumped (depending on site features) to a land base where it can be further dried with the final concentrated solid cake disposed of by one of various processes including on-site or off-site incineration or transport to off-site anaerobic digesters, composting facilities or landfill.

Our financial model of waste capture and treatment takes account of typical transport distances to disposal sites in the main aquaculture areas in Scotland, as well as all regulatory costs, depreciating capital costs and operating costs. On this basis, we have derived total costs of £0.32 – £0.35 per post-smolt produced. This does not include the costs of the CCS and its operation. We would caution though, that there could be wide variation between sites in these potential costs attributable to the distribution of current centralised facilities for disposal of the potential final product (composting, landfill or anaerobic digestion). The potential for collaboration between operations on a regional basis could improve both the financial and the logistical aspects of waste treatment.

We have derived capital costs for a single 6,000 m³ CCS unit and the associated shore-based waste treatment. This is because we have made the assumption that the initial de-watering of the solid waste will be carried out on the floating CCS unit and at the present state of development of commercial CCSs it seems more likely that commercial producers will evaluate their use on a unit-by-unit basis. Clearly, given further development of technologies and methods of operation, there could

be centralised de-watering systems serving several CCSs but for the simplicity of the model that has not been done in this study.

Similarly, the size and capacity of the land-based waste processing equipment has been calculated and costed for a single 6,000 m³ CCS unit. However, in the case of the land-based equipment this could potentially treat batches rather than working continuously so economies of scale could be realised. Again though, for simplicity and consistency we have derived the costs for the equipment required to service a single CCS unit as this probably represents the most expensive case.

8.5 CCS system availability, development and costs

We have reviewed the current status of CCSs in section 2 and proposed a financial model for their operation in section 7. Whilst there is clearly considerable interest in the concept of CCS as a nursery system for marine farmed fish, there is not yet wide-spread adoption of any particular CCS technology into routine operation. Nevertheless, commercial systems are apparently available from at least three manufacturers (Botngaard, Ecomerden and Aquafarm Neptun). All three manufacturers state compliance with Norwegian Standard NS9415 (2009) and certified operating capabilities including significant wave height (Hs) between 1 and 2m, design wind velocity of 30 m/s and current velocities of 0.75 m/s.

An analysis of the additional capital and operating costs for CCSs compared with conventional open systems (section 7) derived total operating costs (based on a system of 6 x 6,000m³ units with a supporting service raft) including the waste capture and processing costs (described above) of ~£0.77 - £0.81 per 1,000g post-smolt produced. Expressing the capital costs of the CCS and waste capture and processing equipment in terms of annual depreciation costs allocated per post-smolt produced per year, with depreciation periods based upon the manufacturers' own recommendations we derived a capital cost allocation equivalent to between £0.82 and £1.67 per post-smolt produced over the anticipated lifetime of the CCS equipment.

8.6 Summary of the Financial Model

Table 8-1. Summary of the financial model

	Additional capital costs per post-smolt	Additional operating cost per post-smolt including regulatory charges	Total additional costs per post-smolt, capital depreciation added
Waste treatment	£0.21 - £0.23	£0.11 - £0.15	£0.32 - £0.38
CCS system and operation	£0.61 - £1.44	£0.66	£1.27 - £2.10
Total CCS operation and waste collection and treatment additional costs:			£1.59 - £2.48

For a 4.75kg average weight fish at harvest (and assuming 10% post-smolt mortality to harvest) this represents a production cost of between £0.37 and £0.57/kg fish produced. On the basis of production costs of £4.37/kg (based on The Scottish Salmon Company's financial report for the first 9 months of 2018 – (Intrafish 2018)) this represents an 8% to 13% increase in costs.

The distribution of the components of the total cost can best be viewed by comparing the pie charts in Figure 8.1 below:

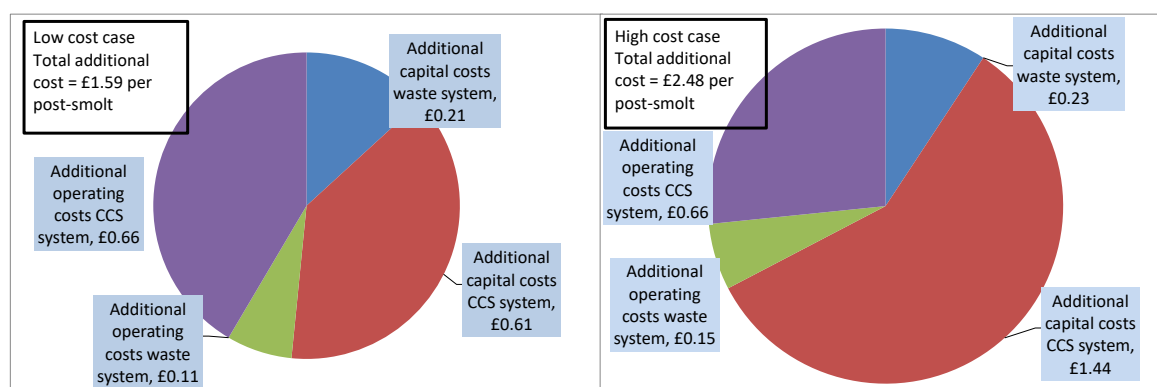

Figure 8-1. Total capital and operating costs for CCS for “low cost” and “high cost” case, expressed as cost per post-smolt

For the low-cost case (left), the additional capital costs attributable to using the CCS nursery expressed as a cost per post smolt (by depreciating the cost and allocating it to production) represents 51.6% of the total costs; for the high-cost case, the equivalent value is 67.3%.

The significance of the capital cost as a proportion of the derived total cost, particularly in the high-cost situation, demonstrates a weakness of this financial analysis. The “capital cost per post-smolt” figure is derived from the system capital cost and the assumed depreciation period – about which there is inevitably a degree of uncertainty, given the lack of experience from deployment of the range of systems available under various site conditions. So, a variation in the assumption of the life of the equipment will have a substantial effect on the projected cost per post-smolt.

Of course, the additional capital cost per post-smolt produced would be significantly reduced if stocking densities could be increased. We have assumed that under the current RSPCA welfare standards for farmed Atlantic salmon (RSPCA 2018) the site maximum stocking density of 15 kg/m³ would apply but a compelling argument could be made that a CCS is more equivalent to a land-based fresh water tank for smolts (>50g) for which the RSPCA stipulates a maximum stocking density of 60 kg/m³. If that were regarded as acceptable, it would result in a reduction of the allocated capital cost for the containment system being reduced by 75%.

8.7 The potential of the Scottish marine aquaculture industry to sustain the increased costs of CCS

An 8% to 13% rise in production costs is clearly undesirable. However, the prospects of additional costs must be seen in the context of the prevailing demand for change in the industry. Any alteration to the *status quo* which is made to reduce the impact of marine aquaculture on the environment is likely to have an associated cost; moving to offshore, deep, well-flushed sites as demanded by the most recent SEPA sector plan will have associated costs of operation as well as demanding more substantial production systems with higher costs than is currently the case for conventional systems.

The use of CCS could be viewed both as a means to reduce the environmental impact as well as improving fish health and increasing the efficiency of use of ongrowing sites. If more expensive,

offshore sites are developed it is in producers' interests to maximise the efficiency of use of those sites and an integration of CCS nurseries with such sites should offer a means to achieve those efficiencies.

Finally, the derived additional costs of using CCS nurseries should be considered in the context of the overall financial status of the industry. It can be argued that an increase in overall production costs of between 37p and 57p/kg is sustainable with current margins. However, the salmon market price and operating costs are susceptible to quite large fluctuations - for example, The Scottish Salmon Company reported EBIT per kg of £0.95 for the third quarter of 2018, whilst the average EBIT for the first three quarters was £1.75 (Intrafish 2018).

9 Conclusions

We have conducted a technical and financial analysis of the potential use of floating CCS nurseries to provide 1kg post-smolts for ongrowing in conventional systems in Scotland. Much of our analysis is based upon assumptions about costs of system elements and technical performance of systems which could be challenged or found to be inappropriate in the context of experience from future trials with CCSs. We have attempted to describe our methodology and the assumptions made in sufficient detail that others can make use of the approach, whilst adjusting values as they feel fit.

We have derived total additional costs of production of salmon, including an allowance for CCS capital depreciation, of £0.37 to £0.57/kg. In the context of published current EBITs for the major production companies in Scotland of £1 – 2 per kg, the additional cost of using CCS nurseries would not seem to be sufficiently great as to be a “show-stopper”. Whilst any increase in production costs is undesirable, the industry is facing challenges summarised by the statement from the ECCLR’s report to the Scottish Government’s investigation into the environmental impact of salmon farming, that “The *status quo* is not an option”. Any new developments which will enable sustainable growth in the industry must show new approaches to the control of environmental impact and will inevitably come at some cost.

The additional costs should always be judged in the context of the benefits of the use of CCS nurseries. We have shown potential financial savings of £0.12 to £0.17 per kg from reduced sea lice treatment costs. There would also undoubtedly be a wider benefit in terms of consequential losses and reduced performance from lice infestation.

The removal of 80% of the solid wastes from the environment for the nursery stage is clearly a further benefit but which is not reflected in a financial cost saving.

As yet, there is no accepted best approach to the design of CCSs. Those which use flexible membranes offer the lowest capital cost but when the depreciation rate was considered in our analysis, the commercially-available Botngaard flexible system proved to be more than twice as expensive as the GRP system of Aquafarm. Our design exercise for a maximum strength concrete system produced such high capital costs as to make that approach unrealistic. Lightweight concrete may offer possibilities for a more robust rigid system but further development and testing would be required.

The observation above, exposes a weakness in our analysis in that the total costs derived comprise a minimum of 52% capital costs, so the assumption of depreciation period allowed for each component has a substantial effect on the overall cost derivation.

Each type of system requires different consideration of the issues of mooring strengths, resistance to wind, waves and currents and the fluid dynamics of flow regimes within the system. The issues are complex and there is little useful theoretical background to draw upon. The present empirical approach is likely to continue supported by specific programmes of applied analysis.

Nevertheless, complete CCS nursery systems are commercially available today and it would seem that their use could successfully be applied to novel production strategies in Scotland which could lead to more efficient use of existing ongrowing sites, reduced lice infestation and collection of 80% of solid waste from the nursery systems. Adoption of their use in certain circumstances could be considered one means of increasing the rate of growth of the marine aquaculture sector which is necessary if industry targets are to be realised.

10 References

Addfield (2018a). Aqua and Thunder Series Product Specification Sheets. Online: Addfield. Available: <https://addfield.com/machine-categories/aquaculture-incinerators/>

Addfield (2018b). Conversation regarding S-CCS waste disposal at Aviemore UK Aquaculture Conference. [D. Maitland] Personal communication, 24/05/2018.

Addfield (2018c). Phone conversation with Addfield sales representative regarding incinerator equipment capacity and pricing. [D. Maitland] Personal communication, 24/07/2018.

Addfield (2018d). *Thermal & electrical energy recovery*. Online: Addfield. Available: <https://addfield.com/machines/thermal-electrical-energy-recovery-unit/>

Adler, P. and Sikora, L. (2004). Composting fish manure from aquaculture operations. *Biocycle*, 62-66

Agrimarine (2004). Intrafish 6/4/2004. Novel floating concrete salmon farm close to a reality. <https://www.intrafish.com/news/612922/novel-floating-concrete-salmon-farm-close-to-a-reality>

Agrimarine (2009). Intrafish 11/6/2009. AgriMarine testing sea-based closed containment sites in China, Canada. <https://www.intrafish.com/news/628729/agrimarine-testing-sea-based-closed-containment-sites-in-china-canada>

Agrimarine (2009b). The Tye blog 9/9/2009. China scoops BC fish farm technology <https://thetyee.ca/Blogs/TheHook/Environment/2009/09/09/ChinaScoopsFish/>

Agrimarine (2012a). Intrafish 15/3/2012. Storm damages Agrimarine tank. <https://www.intrafish.com/news/490239/storm-damages-agrimarine-tank>

Agrimarine (2012b). Agreement provides entry of the Agrimarine system into the world's largest salmon producing nation. News release on Agrimarine website. <http://agrimarine.com/agrimarine-signs-purchase-and-licensing-agreement-with-norwegian-group/>

Agrimarine Technologies (2015). Agrimarine System™. Online: Agrimarine Technologies. Available: <http://agrimarinetechnologies.com/agrimarine-system/>

AILG (2016). Aquaculture growth to 2030. <http://scottishsalmon.co.uk/wp-content/uploads/2016/10/aquaculture-growth-to-2030.pdf>

AkvaDesign (2014). A sustainable approach to salmon farming. Online: Force Technology. Available: <https://forcetechnology.com/no/aquaculture/cage-farming/akvadesign>

APHA (2018) Closed-containment aquaculture waste and animal by-product regulations. [F. Donaldson, SEPA] Personal communication, 02/07/2018.

Anon (1991). Closed systems floats in fjord. *Fish Farming International* 18: 52.

Aquafarm Equipment (2017). Sustainable, cost-effective fish farming. Brochure: Aquafarm Equipment. <http://aquafarm.no/environment/>.

Aquafarm Equipment (2018). Environment: The Challenges. Online: Aquafarm Equipment. Available: <http://aquafarm.no/environment/>

Berle, H. and Rim, S. (2018). The cost of sea lice and its implications for the future of the Norwegian Aquaculture Industry. MSc Thesis Norwegian School of Economics, Bergen. Available: <https://brage.bibsys.no/xmlui/bitstream/handle/11250/2560665/masterthesis.PDF?sequence=1&isAllowed=y> [Accessed: 17/09/2018].

Blaalid, G. (2014). Sea-based closed containment launch. Fish Farming Expert. Available: <https://www.fishfarmingexpert.com/article/sea-based-closed-containment-launched/>

Botngaard (2018a). Closed Cage Systems - The Future of Salmon Farming. Product Manual, Online: Botngaard. Available: <http://www.botngaard.no/en/products+and+services/closed+technology>

Botngaard (2018b). Conversation between Roy Clarke (Stirling Aquaculture) and Botngaard Representatives at 2018 UK Aquaculture Conference, Aviemore.

Boulet, D., Struthers, A. and Gilbert, E. (2010). Feasibility Study of Closed-Containment Options for the British Columbia Aquaculture Industry. Online: Department of Fisheries and Oceans Canada

Brinker, A. (2007) Guar gum in rainbow trout (*Oncorhynchus mykiss*) feed: The influence of quality and dose on stabilisation of faecal solids. *Aquaculture*, 267, pp. 315-327.

Brooker, A.J., Skern-Mauritzen, R. and Bron, J.E. (2018). Production, mortality and infectivity of planktonic larval sea lice, *Lepeophtheirus salmonis* Krøyer, 1837): current knowledge and implications for epidemiological modelling. *ICES Journal of Marine Science* (2018), 75(4), 1214-1234.

Brown, N., Eddy, S. and Plaud, S. (2011). Utilisation of waste from a marine recirculating fish culture system as a feed source for the polychaete worm, *Nereis virens*. *Aquaculture*, 322-323, pp. 177-183

Calabrese, S. (2017). Environmental and biological requirements of post-smolt Atlantic salmon (*Salmo salar* L.) in closed-containment aquaculture systems. PhD thesis, University of Bergen.

Celis, J. and Sandoval, M. (2010). Agricultural potential of salmon wastes used as organic fertilizer on two Chilean degraded soils. *Soil Solutions for a Changing World*. Brisbane, Australia, August 1-6, 2010. DVD: World Congress of Soil Science, pp. 17-20. Available: <https://www.iuss.org/19th%20WCSS/Symposium/pdf/0574.pdf>

Cermaq (2017). Cermaq applies for 13 development licences for FlexiFarm - closed containment with water treatment against infections. Online: Cermaq. Available: <https://www.cermaq.com/wps/wcm/connect/cermaq/news/mynewsdesk-press-release-2254335/mynewsdesk-press-release-2254335>

Chadwick, E., Parsons, G. and Sayavong, B. eds. (2010). Evaluation of Closed-containment Technologies for Saltwater Salmon Aquaculture. Ottawa, Canada: National Research Council of Canada

Costello M.J. (1993) Review of methods to control sea lice (Caligidae: Crustacea) infestations on salmon (*Salmo salar*) farms. In: *Pathogens of Wild and Farmed Fish: Sea Lice* (ed. By G.A. Boxshall & D. Defaye), pp. 219–252. Ellis Horwood, Chichester - Cited by (Costello 2009)

- Costello (2009).** The global economic cost of sea lice to the salmonid farming industry. *J Fish Diseases*, 32.1 pp 115-118. Available at <https://onlinelibrary.wiley.com/doi/full/10.1111/j.1365-2761.2008.01011.x>
- Cripps, S. and Bergheim, A. (2000).** Solids management and removal for intensive land-based aquaculture production systems. *Aquacultural Engineering*, 22, pp. 33-56
- (CtrlAQUA 2015).** Research centre on closed-containment systems for Atlantic salmon opened. CtrlAQUA press release 28/5/2015. <https://ctrlaqua.no/news/2015/05/28/forskning-pa-lukkede-anlegg-i-gang/>
- del Campo, L., Ibarra, P., Gutierrez, X. and Takle, H. (2010).** Utilisation of sludge from recirculation aquaculture systems. 9/2010. Online: Nofima
- DFO (2008).** Potential Technologies for Closed Containment Saltwater Salmon Aquaculture. DFO Can. Sci. Advis. Sec. Sci. Advis. Rept. 2008/001. Retrieved from: http://www.dfo-mpo.gc.ca/csas-sccs/publications/sar-as/2008/2008_001-eng.htm
- Dufault, R. and Korkmaz, A. (2000).** Potential of biosolids from shrimp aquaculture as a fertilizer in bell pepper production. *Compost Science and Utilisation*, 8 (4), pp. 310-319.
- Dufault, R., Korkmaz, A. and Ward, B. (2001).** Potential of biosolids from shrimp aquaculture as a fertilizer for broccoli production. *Compost Science and Utilisation*, 9 (2), pp. 107-114
- ECCLR (2018).** Environment, Climate Change and Land Reform (ECCLR) Committee report on the environmental impacts of salmon farming. http://www.parliament.scot/S5_Environment/Inquiries/20180305_GD_to_Rec_salmon_farming.pdf
- Ecomerden (2016).** The Cage. Online: Ecomerden. Available: <http://www.ecomerden.com/the-cage.html>
- Ellis T., Turnbull J.F., Knowles T.G., Lines J.A. and Auchterlonie N.A. (2016).** Trends during development of Scottish salmon farming: an example of sustainable intensification. *Aquaculture*, Volume 458, 1 May 2016, Pages 82-99. <https://www.sciencedirect.com/science/article/pii/S0044848616300618>
- EMSP News (2018).** Salmon farmers' investment in fish health delivering results. *European Marine Science Park News* 21/6/2018. <http://www.europeanmarinesciencepark.co.uk/news-events/2018/salmon-farmers-investment-in-fish-health-delivering-results/>
- Ernst & Young (2018).** The Norwegian aquaculture analysis: An overview. Ernst & Young AS. 40pp. [https://www.ey.com/Publication/vwLUAssets/EY_-_The_Norwegian_Aquaculture_Analysis_2017/\\$FILE/EY-Norwegian-Aquaculture-Analysis-2017.pdf](https://www.ey.com/Publication/vwLUAssets/EY_-_The_Norwegian_Aquaculture_Analysis_2017/$FILE/EY-Norwegian-Aquaculture-Analysis-2017.pdf)
- EU (2009).** CLOSEDFISHCAGE (Development of an innovative, cost-effective environmentally friendly closed cage for sea-based fish farming). Project no 232513 funded under the Seventh Framework Programme. Project website https://cordis.europa.eu/result/rcn/92470_en.html
- EU Directive 2008/98/EC 2008,** Waste Framework Directive 2008/98/EC. Available: <https://eur-lex.europa.eu/legal-content/EN/TXT/?uri=CELEX:32008L0098>
- EU Regulation (EC) No 1069/2009 2009,** Animal by-products Regulation 1069. Available: <https://eur-lex.europa.eu/LexUriServ/LexUriServ.do?uri=OJ:L:2009:300:0001:0033:EN:PDF> [Accessed: 08/07/2018]

Fish Farming Expert. (2017). FlexiFarm promises fewer losses, lower costs. Fish Farming Expert. Available: <https://www.fishfarmingexpert.com/article/flexifarm-promises-fewer-losses-lower-costs/> [Accessed: 06/07/2018].

FFE (2017a). Marine Harvest feed plant from high in the Skye. Gareth Moore, Fish Farming Expert 1/11/17 (updated 24/2/18). <https://www.fishfarmingexpert.com/article/marine-harvest-feed-plant-from-high-in-the-skye/>

FFE (2017b). Inverlussa picks up latest and greatest workboat. Gareth Moore and Gustav-Erik Blaallid 24/5/17. <https://www.fishfarmingexpert.com/article/inverlussa-picks-up-latest-and-greatest-workboat/>

FFE (2017c). Marine Harvest makes first transfer from giant fish tank. Fish Farming Expert. Available: <https://www.fishfarmingexpert.com/article/marine-harvest-makes-first-transfer-from-giant-tank/>

FFE (2017d). Fish Farming Expert. 22/12/17. Closed-cage smolt experiment pays off <https://www.fishfarmingexpert.com/article/closed-cage-smolt-experiment-pays-off/>

FFE (2018). SSF rolls out lice skirts after Shetland success. Fish Farming Expert 20/2/18 <https://www.fishfarmingexpert.com/article/ssf-rolls-out-lice-skirts-after-shetland-success/>

FFE (2018b). "Snorkel" cage cuts lice numbers by 80% in trials. Fish Farming Expert 11/4/2018 <https://www.fishfarmingexpert.com/article/snorkel-cage-cuts-lice-numbers-by-80-in-trials/>

FFE (2018d). Salmon farming critic films injured fish in cage at Lewis, Fish Farming Expert 4/9/18 by Gareth Moore. Fish Farming Expert. 4/9/2018. <https://www.fishfarmingexpert.com/article/salmon-farming-critic-films-injured-fish-in-cage-at-lewis/>

Fish Farming Innovation (2016). New generation farms are developed (translated Norwegian -> English using Google Translate). Online: Fish Farming Innovation. Available: <https://www.fishfarminginnovation.com/projects>

Fish Globe (2018). FishGLOBE - better for the farmer - better for the fish. Online: FishGLOBE AS. Available: <https://www.fishglobe.no/home-more>

Forsberg O. (1997). The impact of varying feeding regimes on oxygen consumption and excretion of carbon dioxide and nitrogen in post-smolt Atlantic salmon *Salmo salar* L. *Aquaculture Research* 28 pp29-41, 1997. <https://onlinelibrary-wiley-com.ezproxy.stir.ac.uk/doi/pdf/10.1046/j.1365-2109.1997.00826.x>

Future SEA Farms (1997). The SEA (Sustained Environment Aquaculture) System. Namaimo, B.C., Canada. Future SEA Farms Inc.

Gebauer, R. (2004). Mesophilic anaerobic treatment of sludge from saline fish farm effluents with biogas production. *Bioresource Technology*, 93, pp. 155-167

Gonzalez, R. (2018). Norwegian study shows smaller salmon smolt grow faster in seawater grow-out. Hatchery International. Available: <https://www.hatcheryinternational.com/research/norwegian-study-shows-smaller-salmon-smolt-grow-faster-in-seawater-grow-out-3128>.

Gorle J., Terjesen B., Mota V and Summerfelt S (2018). Water velocity in commercial RAS culture tanks for Atlantic salmon smolts. *Aquaculture Engineering* 81. (2018) 89 – 100

Grant, A., Bostock, J & Muir, J. (2009). Closed containment systems for farmed Atlantic salmon in Scotland: An Appraisal. Report Commissioned by the Scottish Salmon Producers' Organisation. AquaVet Scotland & Institute of Aquaculture, University of Stirling. 36pp.

Grøntvedt R.N., Næs M.B., Kristoffersen A.B. and Johansen B. (2016). Plankton nets as a preventive tool to reduce sea lice (*Lepeophtheirus salmonis*) infestations in salmon farming. Abstracts of Sea Lice 2016

Grydeland, O. (2012). Salmon escape from "closed containment" facility. Fish Farming Expert 20/04/2012. Available: <https://www.fishfarmingexpert.com/article/salmon-escape-from-ldquo-closed-containment-rdquo-facility/>

GSI (2018). Non-medicinal approaches to sea lice management. Review by Global Salmon Initiative <https://globalsalmoninitiative.org/en/what-is-the-gsi-working-on/biosecurity/non-medicinal-approaches-to-sea-lice-management/>

Haaland, S. (2017). Semi-closed containment systems in Atlantic salmon production: Comparative analysis of production strategies. MSc, Norwegian University of Science and Technology.

HIE (2017). The Value of Aquaculture to Scotland – a report for Highlands and Islands Enterprise and Marine Scotland June 2017. Imani Development/Steve Westbrook Economist. <http://www.hie.co.uk/regional-information/economic-reports-and-research/archive/value-of-aquaculture-2017.html>

Hjeltnes B, Bornø, G, Jansen, M D, Haukaas, A, Walde, C (Eds.) (2017), The Health Situation in Norwegian Aquaculture 2016 – Rapport 4b - Norwegian Veterinary Institute 2017. Available at https://www.vetinst.no/...og...health...2017/.../2018_1b_Fish_Health_Report.pdf

Hosteland, L. (2016). Closed-containment proves effective. Fish Farming Expert. Available: <https://www.fishfarmingexpert.com/article/closed-containment-proves-effective/> [Accessed: 06/07/2018].

Hosteland, L. (2016b). Seeds "Salmon Home no 1" (translated with Google Translate). Kyst 10/6/2016. Available: <https://www.kyst.no/article/sjoesetter-salmon-home-no-1/>

Hutton Soils (2018). *Soil analysis service*. Online: The James Hutton Institute. Available: <http://www.huttonsoils.com/>

IntraFish (2009). AgriMarine testing sea-based closed containment sites in China, Canada. IntraFish Media 11/6/2009. Available: <http://www.intrafish.com/news/628729/agrimarine-testing-sea-based-closed-containment-sites-in-china-canada>.

IntraFish (2011). AgriMarine expands closed-containment technology. IntraFish Media 16/3/2011. Available: <http://www.intrafish.com/news/632660/agrimarine-expands-closed-containment-technology>

Intrafish (2018). Lower costs boost Scottish Salmon Company's Q3 earnings. Intrafish 21/11/2018 <https://www.intrafish.com/finance/1637938/lower-costs-boost-scottish-salmon-companys-q3-earnings>

Iversen A., Hermansen, Ø., Andreassen, O., Brandvik, R.K., Marthinussen, A and Nystøyl, R. (2016). Kostnader for lakseoppdrett i konkurrentland Drivkrefter og betydning for

konkurransesituasjonen (Cost drivers in salmon farming...), translated with Google Translate). Report no 40/2016, Nofima. <https://brage.bibsys.no/xmlui/bitstream/id/456026/Rapport+40-2016.pdf>

Jeffery, K.R., McPherson, N., Verner-Jeffreys, D., Taylor, N. and Auchterlonie, N. (2015). Modelling of the potential for shortening the pen-based phase of the salmon on-growing cycle. SARFSP008. www.SARF.org: Scottish Aquaculture Research Forum.

Joestring, H., Blaylock, R., Biber, P. and Ray, A. (2016). The use of marine aquaculture solid waste for nursery production of the salt marsh plants *Spartina alterniflora* and *Juncus roemerianus*. Aquaculture Reports, 3, pp. 108-114

Kyst (2018a). Slik vil AkvaDesign drifte sine utviklingstillatelse (This is how Aquadesign will operate its development licences, translated with Google Translate). Article on kyst.no by Therese Soltveit 12/4/2018. <https://www.kyst.no/article/slik-vil-akvadesign-drifte-sine-utviklingstillatelse/>

Lees, F., Baillie, M., Gettinby, G., and Revie, C. (2009). Strategic Sea Lice Control – Implementation and Impact within Scottish Tripartite Working Group Area Management Agreements. Scottish Government. Available: <https://www.gov.scot/Topics/marine/Fish-Shellfish/TWG/Publications/Other>

Lerøy Seafood (2017). Preline. Online: Leroy Seafood. Available: <https://www.leroyseafood.com/en/sustainability/innovation/preline/>

Lerøy (2018). <https://www.leroyseafood.com/en/sustainability/innovation/preline/>

Liu Y. and Bjelland H.V. (2014). Estimating costs of sea lice control in Norway. Preventive Veterinary Medicine 117 (2014) 469- 477.

Marine Harvest (2018). Marine Harvest Salmon Farming Industry Handbook 2018. http://marineharvest.com/about/news-and-media/news_new2/marine-harvest-osemhg-2018-salmon-industry-handbook/

Marine Harvest (2018b). Marine Harvest feed plant website report. <https://www.mhsfeedplant.co.uk/community/>

Marine Scotland (2013). Monthly average temperatures and salinity at 5 long term monitoring sites. doi:10.7489/1881-1. Online: Government of Scotland. Available: <https://data.marine.gov.scot/dataset/scottish-coastal-observatory-data/resource/e2cffdec-45cb-45a7-a5c2-a985e2051436>

Mereghetti, M. (2018). Salmon giants think big on land-based smolt production. Undercurrent News 18/4/2018. Available: <https://www.undercurrentnews.com/2018/04/18/push-towards-larger-salmon-smolts-the-ultimate-race-of-investments/>

Metcalf & Eddy (2004). *Wastewater Engineering: Treatment and Reuse*. 4th ed. Boston: McGraw-Hill.

Mirzoyan, N., Tal, Y. and Gross, A. (2010). Anaerobic digestion of sludge from intensive recirculating aquaculture systems: Review. Aquaculture, 306, pp. 1-6

Munro L A and Wallace I S, (2018). Scottish Fish Farm Production Survey 2017, Marine Science Scotland. <https://www.gov.scot/publications/scottish-fish-farm-production-survey-2017/>

Nilsen A., Nielsen, K.V., Biering, E. and Bergheim, A. (2016). Effective protection against sea lice during the production of Atlantic salmon in floating enclosures. *Aquaculture*, 466, pp 41-50 (2017)

NNFCC (2018). Biogas Map. Online: NNFCC. Available: <http://www.biogas-info.co.uk/resources/biogas-map/>

Nodland E., (2016). "The number of treatment doses against lice decreases by close to ten percent". News from Elisabeth Nodland - March 2, 2016 (translated with Google Translate) <https://ilaks.no/antall-behandlingsdoser-med-lusemiddel-ned-med-naer-ti-prosent/>

Norwayexports.no, (2016). New development licences spur ocean farming. Article on norwayexports.no 2/5/2016. <https://www.norwayexports.no/new-development-licenses-spur-ocean-farming/>

NS9415 (2009). Norsk Standard revised 2009. Flytende oppdrettsanlegg - Krav til lokalitetsundersøkelse, risikoanalyse, utforming, dimensjonering, utførelse, montering og drift (Marine fish farms - Requirements for site survey, risk analyses, design, dimensioning, production, installation and operation) <http://www.standard.no/en/nyheter/news-in-english/2012/marine-fish-farms/> (English summary and information)

Oppedal F., Samsing F., Dempster T., Wright D.W., Bui S and Stien L.H. (2017). Sea lice infestation levels decrease with deeper 'snorkel' barriers in Atlantic salmon sea-cage *Pest Management Science* 73 Issue 9 Sept 2017 pp 1935-1943 First published: 01 March 2017 <https://onlinelibrary.wiley.com/doi/pdf/10.1002/ps.4560>

Preline (2016). Extended smolt farm is a raceway creating optimal water flow. Online: Preline. Available: <http://www.preline.no/en/extended-smolt-farm>

Ramsden, N. (2017a). Norwegian closed-containment specialist applies for 20,000t salmon licence in Iceland. Undercurrent News, . Available: <https://www.undercurrentnews.com/2017/10/26/norwegian-closed-containment-specialist-applies-for-20000t-salmon-license-in-iceland/>

Ramsden, N. (2017b) AquaNor 2017 - The semi-closed cage that shaves NOK 5/kg off costs. Undercurrent News 15/8/2017. Available: <https://www.undercurrentnews.com/2017/08/15/aquanor-2017-three-firms-up-for-innovation-award/>

Rasmussen R S and Løvstad S.H. (2013). Bat for fiskeopdræt i Norden. Beste tilgjengelige teknologier for Akvakulturi Norden. Jesper Heldbo (Ed). Published by TemaNord. Chapter 12. Open and closed installations in aquaculture (translated with Google Translate). Available at: <https://books.google.co.uk/books?id=8IfRcZSbAcC>

RECC (2018). Salmon Farming in Scotland. Report of the Rural Economy and Connectivity Committee of the Scottish Parliament, published November 2018. Available at <https://digitalpublications.parliament.scot/Committees/Report/REC/2018/11/27/Salmon-farming-in-Scotland#>

Reid, G., Liutkus, M., Robinson, S., Chopin, T., Blair, T., Lander, T., Mullen, J., Page, F. and Moccia, R. (2009) A review of the biophysical properties of salmonid faeces: implications for aquaculture waste dispersal models and integrated multi-trophic aquaculture. *Aquaculture Research*, 40, pp. 257-273

Remen M (2012). PhD thesis, Institute of Biology, University of Bergen. Available at http://bora.uib.no/bitstream/handle/1956/9535/dr.thesis_Mette_Remen_30102012.pdf;sequence=3

Roalseth S.L., Haukenes E and Flatset A-M. (2016). Dette kan revolusjonere havbruksnæringen ("This can revolutionise the aquaculture industry"). Article from Norwegian state broadcaster ("NRK") news website, Publisert 13. juni 2016 kl. 19:00. Translated with Google Translate; available at: https://www.nrk.no/mr/_-dette-kan-revolusjonere-havbruksnaeringen-1.12996161

Rødseth, G.I., (2016). Article in iLaks.no. Beregninger på fem milliarder lusekostnader er bare deler av sannheten and reproduced in LinkedIn: <https://ilaks.no/beregninger-pa-fem-milliarder-i-lusekostnader-er-bare-deler-av-sannheten/>
<https://www.linkedin.com/pulse/behandling-mot-lakselus-kan-ha-kostet-7-8-milliarder-kroner-r%C3%B8dseth?published=u>

Rohold, L. (2018). Will dried sludge from fish farming become a contributor or competitor to the utilisation of municipal sludge. *Aquaculture UK Academic Sessions*. Aviemore, Scotland, 24/05/2018. Presentation: Scanship [Accessed: 24/05/2018]

RSPCA (2018). RSPCA welfare standards for farmed Atlantic salmon. Available online at: <https://science.rspca.org.uk/sciencegroup/farmanimals/standards/salmon>

SAMS (2018). Review of the environmental impacts of salmon farming in Scotland. A consortium led by SAMS Research Services Ltd. January 2018. <https://www.sams.ac.uk/science/research-papers/name-238744-en.html>

Scanship (2018a). The Scanship Process. Online: Scanship. Available: <https://www.scanship.no/marine/aquaculture/>

Scanship (2018b). Scanship wins first in world sludge treatment contracts for sea based closed cage fish farms. Online: Scanship. Available: <https://www.scanship.no/scanship-wins-first-in-world-sludge-treatment-contracts-for-sea-based-closed-cage-fish-farms/>

Scottish Executive (2000). Final Report of the Joint Government/Industry Working Group on Infectious Salmon Anaemia (ISA) in Scotland. Published by the Scottish Executive <https://www.gov.scot/Uploads/Documents/JGIWGRReport.pdf>

Scottish Government (2000). A Code of Practice to Avoid and Minimise the Impact of Infectious Salmon Anemia (ISA) <https://www.gov.scot/Uploads/Documents/ISACodeofPractice.pdf>

Scottish Government (2017). Scottish Fish Farm Production Survey 2016. Scottish Government. Available: <http://www.gov.scot/Publications/2017/09/5208>

SEPA (2015b). SEPA Technical Guidance: Best available technologies for composting. Online: SEPA

SEPA (2015c). Waste sites and capacity information excel. Online: Available: <https://www.sepa.org.uk/environment/waste/waste-data/waste-data-reporting/waste-site-information/waste-sites-and-capacity-excel/>

SEPA (2016). Regulation and monitoring of marine cage fish farming in Scotland - a procedures manual. Attachment I: Guidance on drafting a Marine Cage Fish Farm Licence. Version 5 September 2016 <https://www.sepa.org.uk/media/219167/wat-sg-49.pdf>

SEPA (2017). A framework for a sustainable future for finfish aquaculture in Scotland. Online: SEPAView. Available: <https://www.sepaview.com/2017/06/a-framework-for-a-sustainable-future-for-finfish-aquaculture-in-scotland/> [Accessed: 06/07/2018].

SEPA (2018). The Water Environment (Controlled Activities) (Scotland) Regulations 2011 (as amended) - A Practical Guide. SEPA publication version 8.2, February 2018.

https://www.sepa.org.uk/media/34761/car_a_practical_guide.pdf

SEPA (2018b). Finfish Aquaculture Sector Plan. Draft release for consultation, Nov 7th 2018.

https://consultation.sepa.org.uk/sector-plan/finfishaquaculture/consult_view/

SFI (2018). CtrlAQUA Annual Report 2017. Centre for Research Based Innovation. The Norwegian Research Council. 56pp. <http://ctrlaqua.no/?publication=ctrlaqua-annual-report-2017>

Sharrer, M., Rishel, K., Taylor, A., Vinci, B. and Summerfelt, S. (2010) The cost and effectiveness of solids thickening technologies for treating backwash and recovering nutrients from intensive aquaculture systems. *Bioresource Technology*, 101, pp. 6630-6641.

Skaar, A. & Bodvin, T. (1993). Full-scale production of salmon in floating, enclosed systems. *Fish Farming Technology*. Rotterdam. Balkema. 325-328.

Smith, J. (1985). Fertilizing agricultural land with rainbow trout manure for growing silage corn. *Soil Science Society of America Journal*, 49 (1), pp. 131-134

Solaas, F. Rudi, H., Berg, A. & Tvinnereim, K. (1993). Floating fish farms with bag pens. *Fish Farming Technology*. Rotterdam. Balkema. 317-323.

Solstorm D., Oldham T., Solstorm F., Klebert P., Stien L., Vågseth T and Oppedal F (2018). Dissolved oxygen variability in a commercial sea cage exposes farmed Atlantic salmon to growth limiting conditions. *Aquaculture* 486 (2018) pp 122-129

SSPO (2015). Scottish Salmon Producers' Code of Good Practice

<http://thecodeofgoodpractice.co.uk/wp-content/uploads/2015/02/cogp-chapter-4-seawater-lochs2.pdf>

SSPO (2018). Salmon exports reach record £600m. News item, 9th February 2018.

<http://scottishsalmon.co.uk/salmon-exports-reach-record-600m/>

Stehfest, K. M., Carter, C. G., McAllister, J. D., Ross, J. D., & Semmens, J. M. (2017). Response of Atlantic salmon *Salmo salar* to temperature and dissolved oxygen extremes established using animal-borne environmental sensors. *Scientific Reports*, 7(1), 4545.

<http://doi.org/10.1038/s41598-017-04806-2>

Sterner (2018a). Phone conversation with Willie Campbell (Projects Manager -Sterner) regarding capital costs for waste processing equipment. [D. Maitland] Personal communication, 07/20/2018.

Sterner (2018b). Sterner's fish sludge treatment and gas production. Sterner Promotional Pamphlet,

Strand I.M., Sørensen A.J., Lade P. and Volent Z. (2013). Modelling of drag forces on a closed flexible fish cage. Proceedings of the 9th IFAC conference on control applications in marine systems. Volume 46, Issue 33, pp 340-345. The International Federation of Automatic Control. September 17-20 2013, Osaka. <https://www.sciencedirect.com/science/article/pii/S147466701646180X>

Summerfelt, R. and Penne, C. (2007). Septic tank treatment of the effluent from a small-scale commercial recycle aquaculture system. *North American Journal of Aquaculture*, 69, pp. 59-68

Summerfelt, S. (1999). Waste handling systems. In book: CIGR Handbook of Agricultural Engineering, Volume II: Animal Production and Aquacultural Engineering, Chapter: Chapter 13. Waste handling systems, Publisher: American Society of Agricultural Engineers, Editors: E.H. Bartali, F.W. Wheaton , pp. 309-350. https://www.researchgate.net/publication/281346782_Waste_handling_systems

Summerfelt S., Mathisen F., Holan, A. and Terjesen B. (2016). Survey of large circular and octagonal tanks operated at Norwegian commercial smolt and post-smolt sites. Aquaculture Engineering 74 105-110

The Fish Site (2009). China Scoops BC Fish Farm Technology. The Fish Site, 11/9/2009. Available at: <https://thefishsite.com/articles/china-scoops-bc-fish-farm-technology>

Thorarensen, H. and Farrell, A. (2011). The biological requirements for post-smolt Atlantic salmon in closed-containment systems. Aquaculture, 312, pp. 1-14.

UCN (2017b). Norwegian closed containment specialist applies for 20,000t salmon licence in Iceland. Undercurrent news 26/10/2017. <https://www.undercurrentnews.com/2017/10/26/norwegian-closed-containment-specialist-applies-for-20000t-salmon-license-in-iceland/>

UK Environment Agency (2010) Standard rules SR2010No4 Mobile plant for landspreading (land treatment resulting in benefit to agriculture or ecological improvement). The Environmental Permitting (England and Wales) Regulations 2016. SR2010No4. Online: UK Government. Available at: <https://www.gov.uk/government/publications/sr2010-no4-mobile-plant-for-land-spreading>

Undercurrent News (2012). Norway suggests handing out 45 "green" licences. Undercurrent News 12/11/2012. <https://www.undercurrentnews.com/2012/11/09/norway-suggests-handing-out-45-green-salmon-licenses/>

Undercurrent News (2014). Salmar to appeal green licences rejection. Undercurrent News 22/5/2014. <https://www.undercurrentnews.com/2014/05/22/salmar-to-appeal-green-licenses-rejection/>

Unger, J. and Brinker, A. (2013) Feed and treat: What to expect from commercial diets. Aquacultural Engineering, 53, pp. 19-29.

World Sea Temperatures (2018). United Kingdom Sea Temperatures. Online: WorldSeaTemperature.org. Available: <https://www.seatemperature.org/europe/united-kingdom/>

WRAP (2016). Comparing the costs of alternative waste treatment options -WRAP gate fees report 2015. Wrap Gate Fees Report. Online: Waste and Resources Action Program. Available at: <http://www.wrap.org.uk/content/wrap-gate-fees-report-2015-download-summary-report>

Yeo, S., Binkowski, F. and Morris, J. (2004). Aquaculture effluents and waste by-products characteristics, potential recovery and beneficial reuse. NCRAC Technical Bulletins. 6 North Central Regional Aquaculture Center. Digital Repository: Iowa State University. Available at: http://lib.dr.iastate.edu/ncrac_techbulletins/6

Zhang, X., Spanjers, H. and van Lier, J. (2013). Potential and limitations of biomethane and phosphorus recovery from sludges of brackish/marine aquaculture recirculation systems: A review. Journal of Environmental Management, 131, pp. 44-54

Zhang, X., Ferreira, R., Hu, J., Spanjers, H. and Lier, J. (2014). Improving methane production and phosphorus release in anaerobic digestion of particulate saline sludge from a brackish aquaculture recirculation system. *Bioresource Technology*, 162, pp. 384-38

Zugarramurdi, A., Parin, M. and Lupin, H. (1995) Economic engineering applied to the fishery industry. *FAO Fisheries Technical Paper*. 351. Online: FAO. Available: <http://www.fao.org/docrep/003/v8490e/V8490E00.HTM#Contents>

11 Abbreviations/Acronyms

Cardinal points/directions are used unless otherwise stated.

SI units are used unless otherwise stated.

CCS	Closed Containment System
CCSs	Closed Containment Systems
g	Acceleration attributable to gravity
GRP	Glass-Reinforced Plastic (fibre glass)
ISA	Infectious Salmon Anaemia
MAB	Maximum Allowable Biomass
MPA	Marine Protection Area
PMF	Priority Marine Features
ρ	Density of seawater
RAS	Recirculated Aquaculture System
RSPCA	Royal Society for Prevention of Cruelty to Animals
SAH	Scottish Animal Health
SEPA	Scottish Environmental Protection Agency
SHN1	Salmon Home No 1
SS	Suspended Solids
SSPO	Scottish Salmon Producers' Organisation
TS	Total Solids
UHD-PE	Ultra-High Density Polyethylene

Appendices

Appendix One - SARF SP011 Terms of Reference

CALL FOR PROPOSALS



RESEARCH REQUIREMENT

PROJECT	SARFSP011	Technical Considerations of Closed Containment Sea Pen Production for some life stages of salmonids
----------------	-----------	--

Context:

1. Sea Lice Management

Research and more applied efforts to address sea-lice infestation of farmed Atlantic salmon, and rainbow trout in the marine environment continue to focus chiefly on minimising and controlling infestations and associated impacts for what might be considered to be the existing or common marine production method, namely single generation stocking of smolt into open pens at discrete locations and their subsequent on-growing to harvest.

However means of reducing sea-lice impacts through utilisation of **alternative production scenarios** have also been considered, looking to reduce exposure to infestation and similarly reduce associated veterinary treatment frequency and potential for deleterious interactions. These look to offer additional prospects for dealing with (living with) the presence of sea-lice alongside the currently available suite of veterinary and now increasingly-used biological controls such as cleaner fish.

Recently published research supports industry's long-known experience of the significant positive effect on lice infestation of **fallowing** sites for a period that exceeds the infective cycle of the parasite, synchronously over multiple sites within discrete biological areas, particularly compared to the effects of veterinary treatments. Current open sea pen farming practice means fallowing is carried out after each production cycle, essentially once every second year. An economically viable production strategy that can minimise the exposure of farmed fish to sea-lice during the seawater production phase should remain an ambition for producers, particularly in areas already heavily reliant on veterinary intervention.

In essence, there is a need to consider practical approaches to shortening the final marine open pen growout stage of salmonid production to less than 12 months, with a view to allowing longer or more effective fallowing of sites.

2. Improved Production Economics

Whilst sealice control is the primary context for this SARF research project, it is also possible that the approaches considered below could result in some overall reduction in production costs for the species concerned.

Background:

A recent SARF project (SARFSP008) investigated the technical and economic use of sea-water RAS for land-based production of larger (circa 1kg) fish for sea-pen stocking with a view to reducing the marine open-pen on-growing period to achieve the reductions in exposure/treatments and provided an economic model to allow the costs of production for such a split sea-water phase system to be evaluated by businesses. From a terminology point of view, such a facility could be described as a **nursery** unit, producing larger juvenile fish, ready to be stocked into open sea pens for a final sub-12 month growout phase.

While land-based seawater RAS offers flexibility, security, control and the ability to utilise coastal areas that would not for exposure/environmental or other reasons accommodate sea-pens, this comes at a cost and as a result may be restrictive in its ability to produce high volumes of larger fish required for expanding production. Certain remoter areas may also lack infrastructure of the nature required for larger RAS systems: road access; availability of sufficient electricity; staff accommodation issues.

An alternative to land-based (RAS or more traditional) is to consider a **closed containment sea pen nursery system**. Some of the outputs of the SARF project above might be appropriate when assessing the potential contribution of closed containment sea pen use. Such a study would complete 'the SARF set' of alternatives for closed seawater containment production, but it should be stressed that SARF anticipates investigation of closed sea pen use for only part of the marine farming cycle, such that whatever systems are used, their benefits are maximised and their drawbacks minimised. Fully contained enclosed pen production of fish up to market-harvestable size is not an objective of this research proposal.

Many companies have invested in freshwater RAS and some of these have the reported ability to produce large, or very large, S1/S0 smolt. Utilising closed containment pens in the sea for part of the marine on-growing phase for such smolt could allow for volumes to be accommodated, in the absence of the premium on space utilisation/cost that may occur on land. In addition, closed containment sea-pen use might offer, for example:

1. Reduced energy/cost required for pumping seawater compared with land-based RAS
2. Bio-secure water input in terms of infective planktonic stages of sea lice, by way of abstraction from deeper water or through other forms of intervention – filtration, disinfection
3. Inherent natural water temperature control: seasonal temperature control can be a cost factor in land based RAS
4. Utilisation of (some existing) sheltered, near-shore locations since untreated wastes will not be released directly to the environment, and exchange will be provided by pumping rather than relying on natural water flows.

5. Consequent access, shore connection and servicing ability advantage over 'normal' sea pen sites to maximise security and production efficiency, where cage systems could incorporate weather-related shielding/mitigation design free of its impacts on water exchange.

There are several areas of uncertainty about the technical and economic viability of closed containment sea pen nursery systems, and this Call for Proposals is intended to address these.

Outline Research Requirement:

SARF requires theoretical but well-evidenced research that investigates the technical and economic feasibility of incorporating fully closed containment sea pen systems within the overall production process for Atlantic salmon and marine-grown rainbow trout in Scotland.

Impact:

All SARF applied research projects must consider the opportunity for project outcomes to contribute to further activities that might, in due course, lead to measurable positive impacts on Scottish aquaculture production. Scottish aquaculture products are now traded around the world, and salmon farming is currently the highest-value single food product export from Scotland, bringing positive benefits in terms of economic activity and social cohesion in some of our most remote coastal areas. Atlantic salmon farming is contributing greatly to 'seafood security' for Scotland and more widely for the UK. The opportunities for large marine grown rainbow trout are also compelling.

The overarching goal of this research is to ascertain whether partial closed containment marine production, in conjunction with larger smolts / juveniles from freshwater, could lead to a situation where open pen marine final on-growing can be undertaken on sites with an ability to have a 6 to 8 week fallow period **every** calendar year. In effect reducing open pen use to circa 10 months per generation stocked, grown and harvested. This would allow the period of greatest fish weight production to be on open-pen sites with the necessary flushing and exchange to accommodate it, but able to fallow more frequently. This could maximise the gains from non-pharmacological sea-lice controls, while helping retain their efficacy if and when required. Reduced reliance will also allow more confident exploitation of modelled biomass limits.

Objectives:

The setting of clearly defined and measurable project objectives is a matter for applicants to suggest to SARF. The overarching goal of the research has been covered above, and several distinct components have been identified. The specific research objectives are:

1. Provide at least **two** design detail and operating models for enclosed marine pen nursery units, itemising:
 - a. Dimensions
 - b. Materials
 - c. mooring options
 - d. water exchange rates

- e. supplementary aeration/oxygenation
 - f. filtration options
 - g. Energy consumption
 - h. siting preferences
 - i. shore facility requirements
2. For a) Atlantic salmon and b) rainbow trout, develop biological crop models, showing rate of growth to target final size (1000g), starting with different assumptions of juvenile fish input size and time of year for stocking. Include feed conversion and feed consumption components.
 3. Develop a detailed proposal for the technicalities and economics of managing the waste stream from these units. Consider the exit solids-capture structures, taking into account constant flow conditions but also infrequent 'flushing' of sumps and pipes. How will the solids be captured at the surface of the structure. How will they then be subsequently treated (dewatered, stored, transported, disposed of). In general, consider any environmental impact aspects of the proposed designs.
 4. Develop full financial models for each design option:
 - a. Detailed fixed asset costs including installation
 - b. Full operating costs, culminating in final cost of production per 1000g fish
 5. Consider the positive or negative effects of utilising an enclosed pen nursery phase in the overall production cycle for both species, including:
 - a. Overall production economics
 - b. Integration into production continuity for a large-scale aquaculture business, especially with regard to meeting market demands

Approach:

It is likely that a successful project could not be undertaken without extensive consultation with the aquaculture industry in Scotland, as well as with other experts in different technical fields. In order to partially fulfil this need, successful applicants will be expected to **incorporate the British Trout Association (BTA) and the Scottish Salmon Producers Organisation (SSPO) within their project 'team'**. Costs incurred by these organisations will be reimbursed directly by SARF, and are not included in the indicative budget below. There is no stipulation that applicants should discuss their proposals with BTA or SSPO before submitting the final application, but that option remains available.

With the assistance of the BTA and SSPO, it is likely that wider consultation with aquaculture companies will also be required.

It is likely that the project would include a comprehensive review of all previous efforts to raise salmon (or trout if applicable) in closed containment pens, together with more recent advances in general aspects of contained aquaculture. It should be noted that:

- Previous attempts to raise salmon in such systems were predicated on basing the full production cycle in them, **rather than on shorter-term utilisation as suggested in this project**
- Whilst advances in techniques used in RAS are of interest, it is likely that an economically



and technically optimal closed containment pen system only requires certain aspects of the techniques associated with RAS.
Project Management: There will be a SARF Steering Group assigned to this project. (Applicants should factor the cost of attending 3 steering group meetings, possibly in Edinburgh, into their applications.)
Deliverables: A Draft and then Final Report

Anticipated Duration:	9 months
Maximum Cost:	£70,000 including VAT
Proposed Start Date:	January 2018
Commissioning Mode:	Open Competition
Deadline for Applications:	Friday 20 th October 2017
Application Forms:	Application forms together with SARF's standard terms and conditions of contract are available at: http://www.sarf.org.uk/downloads.html
Contact:	Richard Slaski – email: r.slaski@sarf.org.uk Tel: 01387 740098
NOTE	This is a SARF Special Project, co-funded by Marine Scotland and The Crown Estate

Appendix Two - Summary details of existing CCS design and deployment

This appendix provides details of floating closed containment systems which are at a significant level of development – either in production and commercial use or at an advanced evaluations stage in reasonable scale. Most information has been obtained from fish farming press publications.

System common name:	AgriMarine System Version [1 & 2]
Company and associated companies:	(Currently) AgriMarine Holdings Inc (Canada), Agrimarine Technologies Inc , AgriMarine Norway AS ("AgriNor")
History of company involvement in CCS:	<p>Long involvement in aquaculture in Canada, initially as producers and hatchery operators and more recently, in addition, technology developers. Corporate structure has changed over time.</p> <p>In 2004, reported (Agrimarine2004) development of "floating closed-containment concrete salmon farm with its own waste collection system".</p> <p>In 2009 AgriMarine established (Agrimarine2009b) a production business in China, with Chinese investment, for trout production using their sectional GRP floating tanks. This remains in operation.</p> <p>In 2011, AgriMarine established (Agrimarine2011a) a joint venture company AgriMarine Norway AS (which appears no longer to exist) to establish a closed-containment demonstration site for their proprietary technology.</p> <p>In 2012, one of their systems suffered substantial storm damage (Agrimarine2012a)</p> <p>In 2012, AgriMarine sold two tanks to Akvatch AS for a demonstration project to be part-funded by Innovation Norway. The deal also included a transfer of certain IP rights to Akvatech ASA (Agrimarine2012b).</p> <p>In 2013, the agreement with Akvatech was terminated (Agrimarine2013) and the company went through a major re-financing and re-structuring with major investment from Dundee Corporation, and in 2015 became amalgamated (Agrimarine2015) as a private company within the Dundee group..</p>
Useful websites:	Agrimarine Technologies Inc (Canada) ,
Development company/partners	AgriMarine, Agrimarine Technologies Inc (Canada),
Closed containment technology:	Sectional GRP reinforced with steel (video of construction process).
Technical details:	Version 1 construction can be seen in the video up to 2m 23s. In the second half of the video (from 2m 35s) Version 2 is shown which is very different and appears to depend upon a central steel scaffold for rigidity.

	<p>Water supply from pumps incorporated in GRP collar (see picture opposite). It's not clear what happens to the water supply system in version 2.</p>	
<p>Images:</p>	<p>Version 1</p>  <p>Version 2</p> 	

	
Any performance data:	None found
Status/licences:	
Other:	<p>AgriMarine System Version 1 appears to be identical to the design of Aquafarm Equipment “Neptun” Possibly linked through this news report reporting the sale of assets and intellectual property rights to Akvatech, a Norwegian private equity group. This supposition appears to be supported by a presentation by Akvatech (Akvatech2017) which links the technologies of AgriMarine and Aquafarm Equipment.</p>
Associated IP	<p>Espacenet search found two patents/patent applications (AgrimarineEspacenet):</p> <ul style="list-style-type: none"> <input type="checkbox"/> 1. AQUACULTURE REARING ENCLOSURE AND CIRCULATION INDUCTION SYSTEM <input type="checkbox"/> 2. SOLID WALL CLOSED CONTAINMENT AQUACULTURE SYSTEM

System Name:	AkvaDesign
Company:	AkvaDesign AS (Norway), AkvaFuture
Company details:	<p>Akvafuture was established in 2014.</p> <p>AkvaDesign AS, and its subsidiaries AkvaFuture AS and AkvaDesign Systems AS, are registered and based in Brønnøysund in northern Norway. AkvaFuture AS operates farms; AkvaDesign Systems manufactures the systems and provides service and maintenance.</p> <p>AkvaFuture aims to harvest 6,000t within 2 years at its site near Brønnøysund AkvaFuture ehf is engaged in developing fish farming activities in Iceland and has applied for licences in Eyjafjordur.</p>
Useful websites:	AkvaFuture , Force Technology
Development company/partners	Force Technology (technology consultancy company)
Closed containment technology:	Design specifications were for cages which could be grouped together and could withstand 2m waves.
Technical details:	<p>Wide floating collar in concrete with polyester "skirt" containment system – appears to be hemi-spherical. Cage diameter 30m⁴ and has volume of 6,000m³. Inflow pumped from -25m. Sludge removed from bottom of "cage" and "used as fertiliser or biofuel". Also has "double layer of safety net and "strong-fiber cloth" (AkvaDesign2017b). Floatation appears to be plastic floats on individual pens. The decks (concrete?) for the individual pens are octagonal, allowing pens to be nested with square spaces between.</p> <p>Pumps appear to be located on individual pens, near surface, (see pictures)</p> 

⁴ NB diameter reported as 90m(!) but must be ~28 from back-calculation

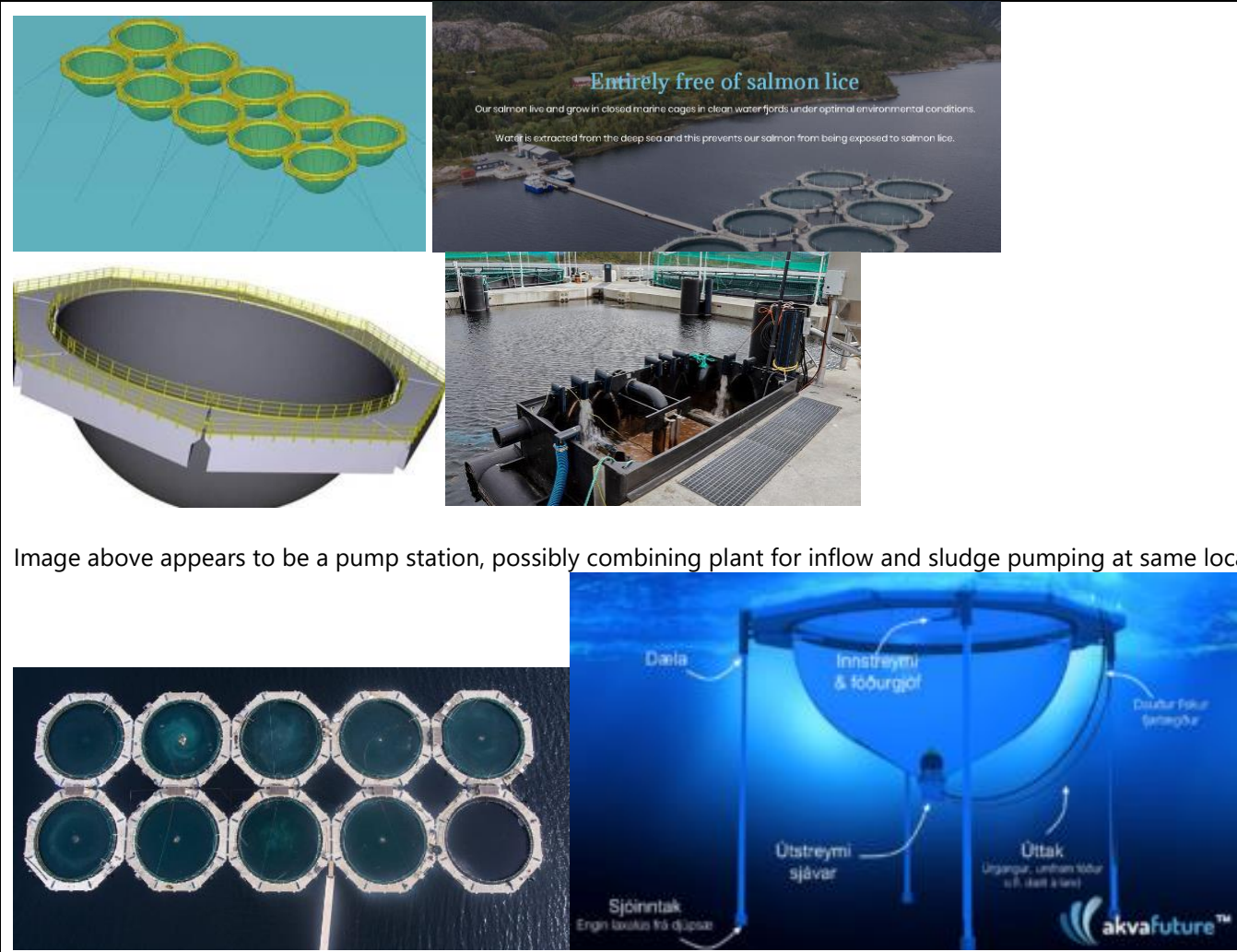
<p>Images:</p>	 <p>Image above appears to be a pump station, possibly combining plant for inflow and sludge pumping at same location</p>
<p>Technology/Project history:</p>	<p>AkvaDesign has designed a new closed offshore system. Hired Force Design to complete design.</p>
<p>Any performance data:</p>	<p>Very few details available, though it is clear they have produced post-smolts in the 10-cage unit shown in the</p>

	photographs – probably at Brønnøysund.
Status/licences:	Was turned down for (10) development licences in July 2016 (AkvaDesign2016). On appeal, a revised 2-concession licence was granted in April 2018 (AkvaDesign2018)
Other:	NB around 30/4/18 Force Technology dropped aquaculture as a strategic sector and all details of AkvaFuture from their website
IP	<p>A patent search on Espacenet identifies 7 patents/patent applications assigned to AkvaDesign (AkvaDesignEspacenet). They include:</p> <ul style="list-style-type: none"> <input type="checkbox"/> 1. OUTLET BASIN FOR A FISH PEN <input type="checkbox"/> 2. FLOATING ELEMENT AND METHOD OF FORMING A BUOYANCY SYSTEM <input type="checkbox"/> 3. MODULAR BUOYANCY SYSTEM AND FLOTATION ELEMENT FOR NET CAGE <input type="checkbox"/> 4. Kobling med koblingsorgan for fastgjøring av en innhegning til et oppdriftslegeme i en merd <input type="checkbox"/> 5. BUOYANCY SYSTEM FOR A FISH PEN <input type="checkbox"/> 6. Kobling for fastgjøring av en innhegning til et oppdriftslegeme i en merd <input type="checkbox"/> 7. Sikkerhetsnett for en lukket merd

System:	AquaDome
Company:	Cermaq
Company details:	Cermaq Group AS is a Norwegian company with subsidiaries in Canada, Norway and Chile. It is a major salmon producer, 100% owned by Mitsubishi Corporation
Useful websites:	https://www.cermaq.com/wps/wcm/connect/cermaq/cermaq/our-sustainable-choice/sustainability-16/projects-and-initiatives/projects-and-initiatives
Development company/partners	In 2012, Cermaq published a fact sheet (AquaDome2012) on the theme of closed containment salmon farm systems. In this, they reported that Developed with manufacturer Maloy-Selskapet MSC AS. Model AquaDome tested at Ewos Innovation site in Dirdal (2012 cermaq fact sheet). .
Closed containment technology:	Was Norway's first certified closed containment system for use at sea. Composite rigid hemisphere, 27m diameter
Technical details:	
Images:	

	
<p>Other:</p>	<p>The development project had cost NOK 26m in May 2014. (AquaDome2014a)</p> <p>First pilot launched late 2014 and destroyed in Hurricane Ole in Feb 2015 (AquaDome2016). Cermaq undertook to have a strengthened design developed (AquaDome2016), but it was reported (AquaDome2017) that there were doubts over its development.</p> <p>Commitment to the AquaDome concept now appears to have been abandoned by Cermaq in favour of FlexiFarm.</p>
<p>IP</p>	<p>No relevant Norway patents registered to Cermaq or any patents from Espacenet</p>

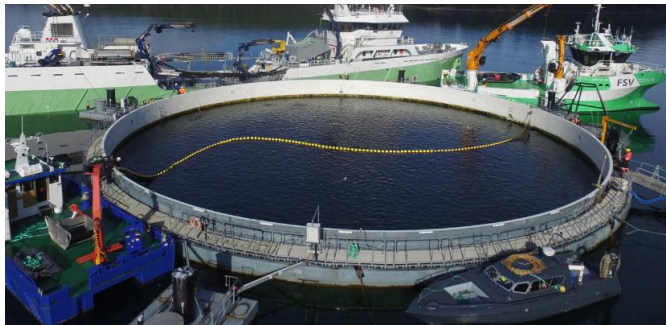
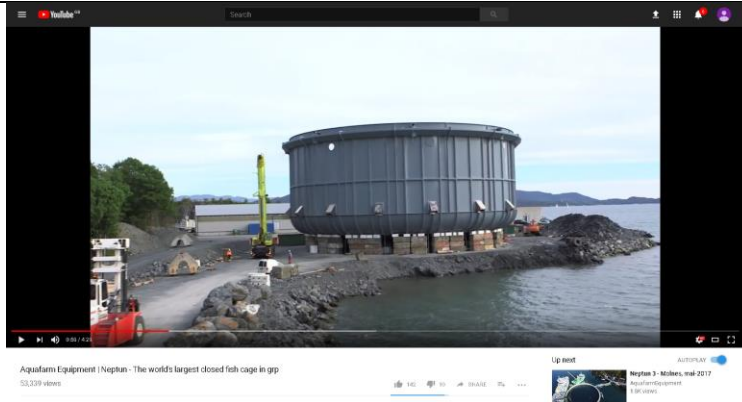
System:	Aquafarm Neptun, Neptun 3
Company:	Aquafarm Equipment AS
Useful websites:	Aquafarm Equipment AS
Development company/partners	Developed in collaboration with Marintek (part of SINTEF)
Closed containment technology:	Lightweight GRP with local reinforcement of high-tensile steel . First pilot system damaged by storm "Nina". Described http://aquafarm.no/closed-cage/ as built from GRP elements and reinforced with steel in areas that endure the most stress.
Technical details:	<p>Second version, 22m deep with 2m freeboard; 40m diameter</p> <p>Pump systems are mounted on linked floating stations. Water enters the pens about 2m below top of freeboard. Outlets (~14 in pen in photos below) are located around the periphery about 1.5m above the base and the outlet flaps can be controlled and their design and function are the object of one of the patents.</p>
Images:	 

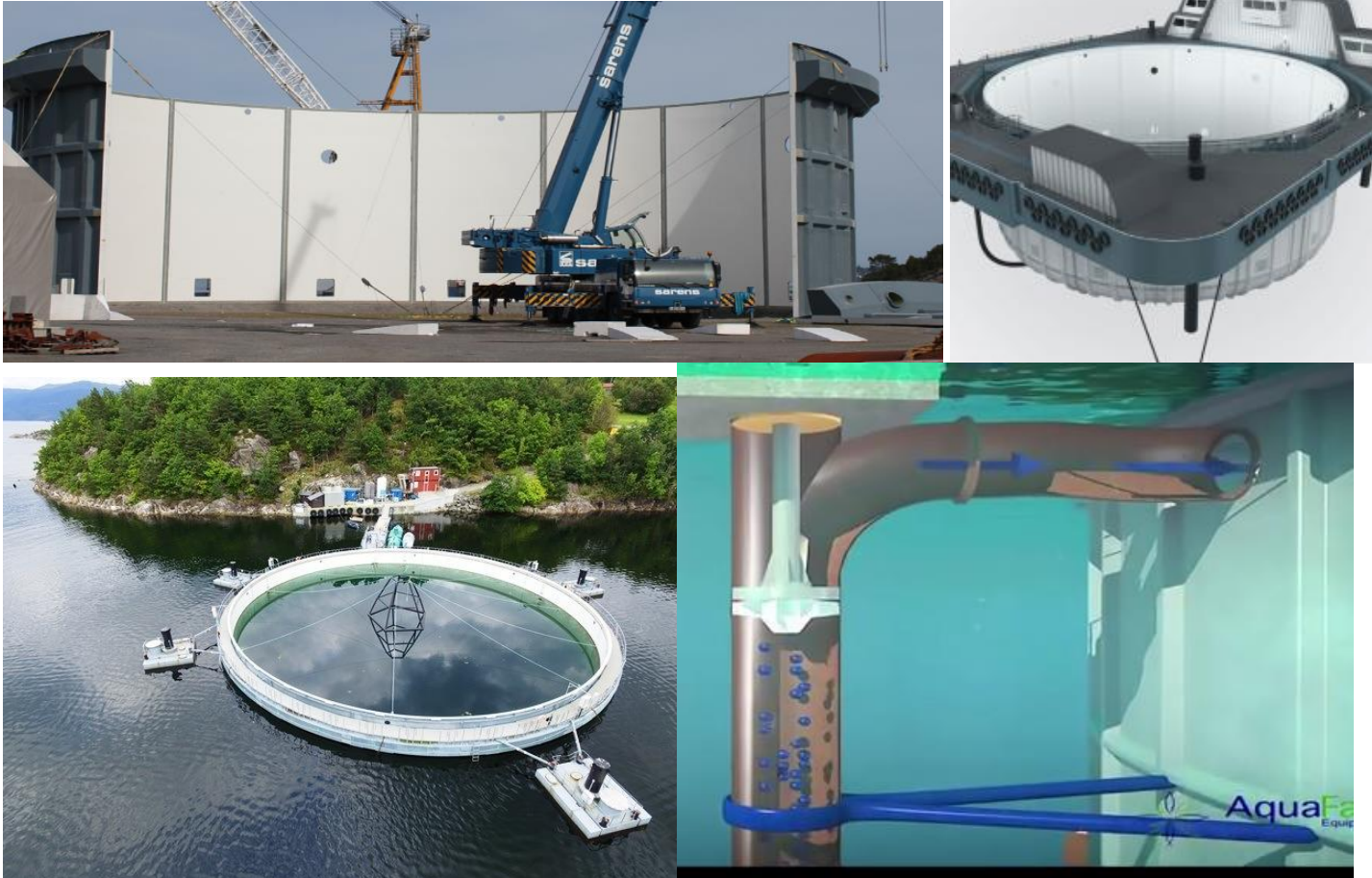
	
<p>Technology/Project history:</p>	<p>The first system was tested by Marine Harvest; stocked in 2014 and damaged by the storm "Nina". In October 2016 the second system was launched for Marine Harvest at its Molnes site (Aquafarm2015)</p>
<p>Any performance data:</p>	<p>The Published performance from Aquafarm's website: Significant Wave Height 1.0m; Maximum wave height 1.8m; Design wind = 30m/s; current 0.75m/s; lifetime = 25 yrs. Certified design and construction to NS9415:2009 and NYTEK</p>

	<p>The first batch of post-smolts was transferred to open cages after six months in CCS. "The tank was stocked with 200,000 fish in the autumn and in six months the salmon have grown from 118 grams to 1.2 kilograms, the company said in a statement." (Aquafarm2017)</p>  <p>(transferring 1kg fish)</p> <p>No useful information on waste handling: "Figures show that salmon faeces is not a problem for the seabed, yet we believe there is an untapped resource. On Molnes, waste is collected and re-used by other companies," (Aquafarm2015)</p>
<p>Other:</p>	<p>Neptun3 MHG trials in Molnes: stocked with 169,000 smolts in Nov 2016. Made of fibreglass and has a 40m diameter on the inside, and a circumference of 126m. 22m deep; 21,000 m3 (~1,000t @50kg/m³) capacity</p> <p>(from catalogue http://aquafarm.no/wp-content/uploads/2017/08/Brosjyre_Aquafarm_eng.pdf) The promising results of Marine Harvest's tests of our post-smolt facility speaks for themselves:</p> <ul style="list-style-type: none"> • Feed factor: 0.85 • Low mortality: < 0.5 % • No need for de-lousing • Zero escapees • No disease registered • Growth: 118 g – 1.2 kg in 6 months • Organic waste: 60–70 % is collected <p>"Low investment cost compared to land based (2000 – 2400 NOK/m3)." So, 42 – 50.4 m NOK</p>

Received [EU development funding](#) under H2020
Aquafarm Equipment AS is a partner in cntrIAQUA

AgriMarine System Version 1 appears to be identical to the design of Aquafarm Equipment "Neptun".
Probably linked through this [news report](#) reporting the sale of assets and intellectual property rights to Akvatech, a Norwegian private equity group. This supposition appears to be supported by a [presentation](#) by Akvatech ([Akvatech2017](#)) which links the technologies of AgriMarine and Aquafarm Equipment.

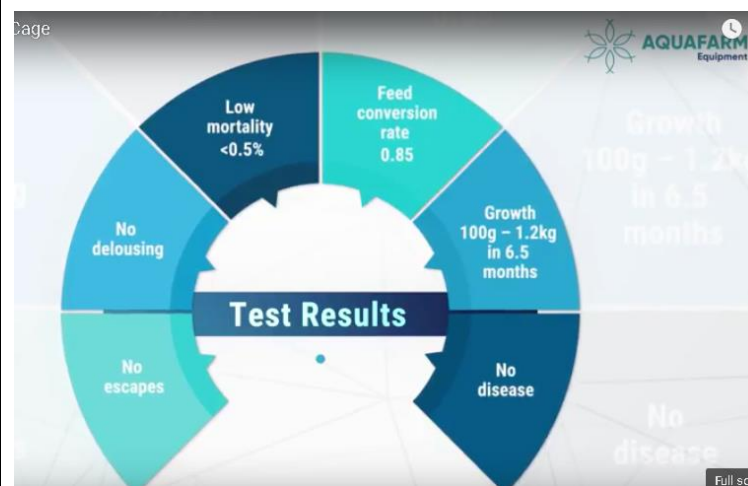

(Video of [launch and operating principles](#))

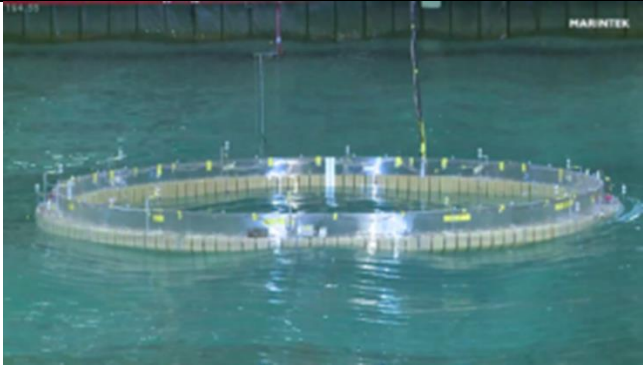
	 <p>Technical data:</p> <ul style="list-style-type: none"> • Inside diameter: \varnothing40 m • Circumference: 126 m • Cage Depth: 22 m • Gross Volume: 21.000 m³ • Significant Wave Height: H_s = 1,0 m • Max Wave Height: H_{Max} = 1,8 m • Design Wind : v = 30 m/s (Severe Storm) • Current: 0,75 m/s • Lifetime: 25 years • Certified design and construction according to NS9415:2009 and NYTEK
Associated IP	<p>An Espacenet search found 5 patents/patent applications by Aquafarm Equipment (AquafarmEspacenet)</p> <ul style="list-style-type: none"> <input type="checkbox"/> 1. FISH CAGE <input type="checkbox"/> 2. WALL PANEL FOR A FISH CAGE <input type="checkbox"/> 3. BOTTOM CENTRAL ELEMENT FOR A FISH CAGE <input type="checkbox"/> 4. BOTTOM PANEL ELEMENT FOR A FISH CAGE <input type="checkbox"/> 5. Luke for merd

System:	Botngaard System
Company:	Botngaard AS
Useful websites:	http://www.botngaard.no/en/products+and+services/closed+technology
Development company/partners	Botngaard's primary focus is the supply of tarpaulins for Aquaculture. However, they appear to be working closely with both R&D partners and producers to develop a range of closed technologies. Development of the technology has included collaboration with Xylem, VARD aqua and SINTEF through three major programmes in 2012 - 15 and sold systems to Bolaks AS and Måsøval AS (broodstock/smolt/egg producers), and Cermaq (ongrowing)
Closed containment technology:	<p>Botngaard's primary focus is the supply of tarpaulins for Aquaculture. They have applied this expertise to closed systems for fresh water storage, containment systems for treatment, broodstock maintenance, harvest systems and latterly for dedicated nursery systems.</p> <p>Uniquely, Botngaard offers a retro-fit service where they offer fabric containment systems to be retrofitted on existing systems. The service includes analysis and upgrading of existing mooring hardware based on the increased demands of the CCS.</p> <p>The main bespoke nursery system is an octagonal fabric pen with floatation provided by a 1.22m diameter pipe. A choice of fabrics can be used – either a “Dynema” fabric with gauge 205 g/m² or the heavier gauge Polyester/PVC composite of 2,250 g/m². The suggested life of the heavier gauge material is 5 years, with the lighter material being 2 years.</p> <p>Depending on size, it has 4 – 6 independent water pumps located around the circumference, pumping from deep intakes to minimise sea lice. Outlets are independently controllable and are positioned at various levels. All pumps are equipped with oxygen injection which is activated on low O₂ levels. The pen is equipped with an array of sensors for O₂, temperature, pH, salinity, turbidity and water level.</p> <p>There is a waste collection sump and outlet pipe which can be used to pump solid waste to collection or discharge at a distance from the site.</p>
Technical details:	<p>For the 8,000m³ system:</p> <ul style="list-style-type: none"> • Diameter 39.2m. float tube diameter = 1.22m, volume = approximately 8,000 m³. Maximum depth of bag

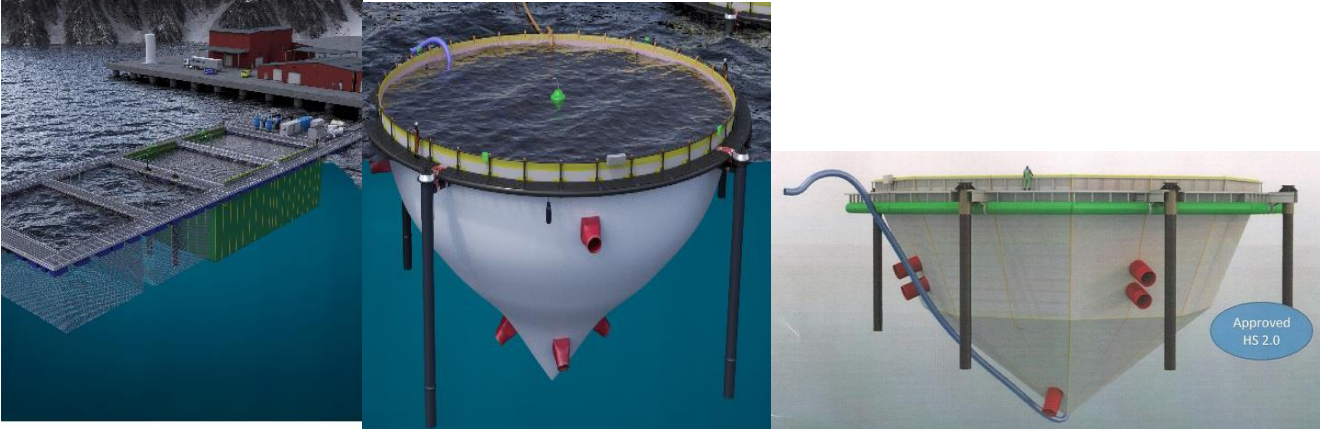
	<p>= 18m</p> <ul style="list-style-type: none">• Pumps = 4 to 6 of ~ 10kW each; rising tubes = 13m long, 800 mm diameter; intake pipes – diameter = 500 mm. Flow capacity = <= 200 m³/min, theoretical total exchange rate = 40minutes.• Automated O₂ injection through "VitaDi diffusor tubes. 40 kg O₂/hr
Images	 <p>The images show three different containment systems. The first image on the left is a 'Retrofit' system, showing a large circular tank with a concrete base and a metal frame. The middle image is a 'Bespoke closed containment system Post Smolt 8000', showing a large circular tank with a white hull and a metal frame, supported by four legs. The right image is another view of the 'Bespoke closed containment system Post Smolt 8000', showing a large circular tank with a white hull and a metal frame, supported by four legs, with a blue pipe connected to the side. A blue circular stamp in the bottom right corner of the right image reads 'Approved H5 2.0'.</p> <p>Retrofit Bespoke closed containment system Post Smolt 8000</p>

Technology/Project history:	Concept	R & D Project	Partners	Period
	Delousing tarp	Delousing with the use of a closed tarp & medicin	SINTEF, FHF, complementary suppliers and fish farming companies	2010-2014
	Perma skirt	Permanent lice skirt to prevent sea lice entering the cage	Sinkaberg-Hansen, SalmoNor, Ellingsen Seafood, Lingalaks, Aqualine, Storvik Aqua, Xylem, Yara, Sintef, Veterinarian Institute (N) and Marine Research Institute (N)	2012-2014
	Fresh water basin	Holding fresh water for treatment	NRS Feøy, Harald Tronstad (PhD), Studsgaard	2015
	Closed holding cage	Seabased closed containment for Kråkøy salmon slaughterery	Xylem, Storvik Aqua, Aquastructures, Sintef, Kråkøy salmon slaughterery	2013-2015
	Closed cage for post-smolt	Seabased closed containment	Smøla hatchery, Sintef, Aqualine, Xylem	2012-2015
Performance data:	As a broodstock system (for Bolaks AS): 80 tonnes of brood fish stocked into CCS with average weight 7 kg. After 6 months, the average weight of females was 13.5 kg and 16.5 kg for males. No treatments or handling were necessary.			
Cost information -	(Verbal) estimate for 8,000 m ³ CCS – approximately £1.2m			
Approvals	Certification to HS = 2m (Significant wave height)			
Intellectual Property	No patents or patent applications assigned to Botngaard were identified in searches of Espacenet or the Norwegian patent office.			

System:	Ecomerden/Ecocage
Company:	Ecomerden
Company details:	Incorporated in 2010 specifically to produce floating closed containment solution.
Useful websites:	http://www.ecomerden.com/
Development company/partners	Serge Ferrari (membranes), Sterner, Xylem
Closed containment technology:	Double-walled flexible membrane ⁵ ; superstructure and floatation in steel. Offered in 2 standard sizes: 6,000m ³ and 12,000m ³ . The membrane is described as dense, flexible, smooth and elastic with a breaking strength of 30 tonnes per metre.
Technical details:	Inflow water is pumped by 4 pump stations and directed tangentially at some depth below the surface to create circular flow. In the 6,000 m ³ system, each pump has a capacity of 700l/s. All inflow pipes are also equipped with oxygen injection.
Images:	

⁵ It's not clear (from Google translate and news articles) whether the inner containment material is a membrane or a conventional net

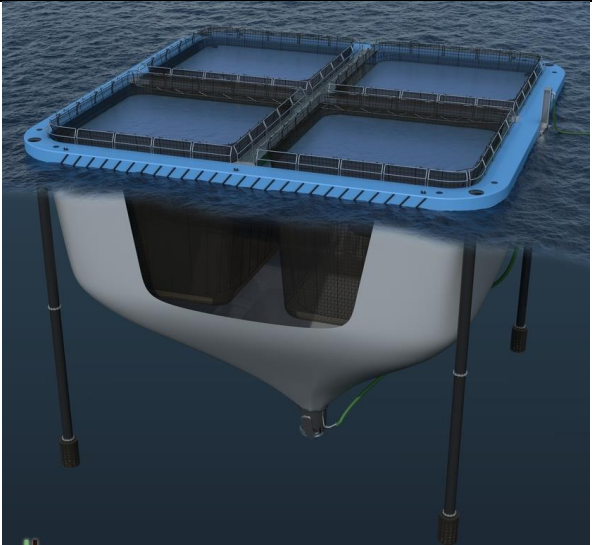
	 <p>They also have promoted a concept design (for ongrowing/processing? Harvest?) (Ecomerden 2017b, in Norwegian, and Ecomerden 2017c, rough translation)</p>
<p>Status/licences:</p>	
<p>Other:</p>	<p>After five years of development the first pilot cage was completed and stocked in 2015 with 200,000 smolts from Sulefisk (Ecomerden2015a).</p> <p>The pilot cage was 6,000m³ with the capacity to produce 1 million salmon per year. The float collar is sinking secure with a reserve buoyancy of 27 tonnes. The bottom ring is “made of the most robust fabric ever made in the marine sector and acts as a stiffener, ensuring that it does not collapse”.</p> <p>In 2016, the design was modified (Ecomerden2016) to include UV filtration in both the intake and the discharge system.</p>

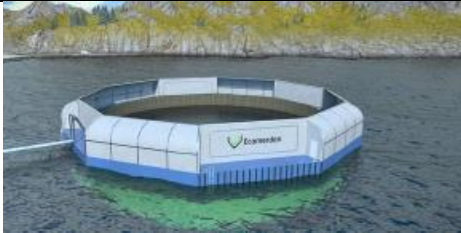
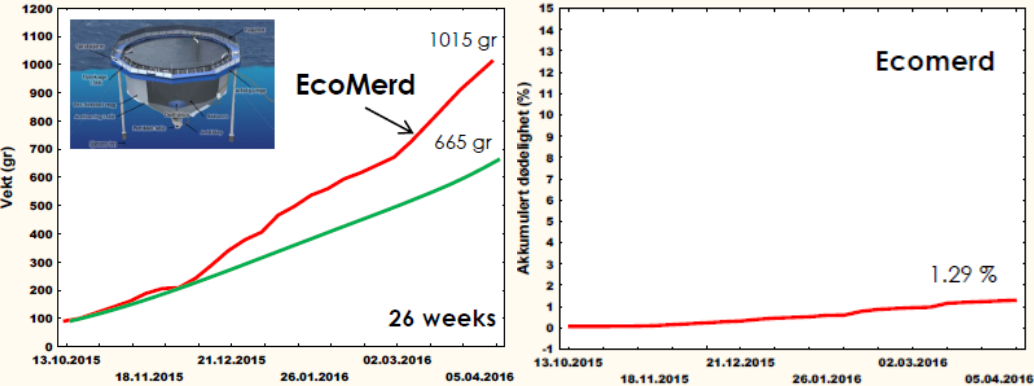
	<p>The floating collar can be constructed in steel or aluminium.</p>  <p>The new design includes raised superstructure to close off the entire system</p>												
<p>Certification:</p>	<p>Ecomerden certificated according to NS9415</p>												
<p>Performance data</p>	 <p>Growth and mortality data from Sigurd Handeland PowerpointPresentation (Eco1)</p>												
	<table border="1"> <thead> <tr> <th colspan="3">Performance data from Ecomerden 2017</th> </tr> <tr> <th></th> <th>Control, open cage</th> <th>Ecomerden Ecocage</th> </tr> </thead> <tbody> <tr> <td>Harvested after week</td> <td>79</td> <td>62</td> </tr> <tr> <td>No of fish harvested (from 1,000,000 input)</td> <td>814,336</td> <td>979,980</td> </tr> </tbody> </table>	Performance data from Ecomerden 2017				Control, open cage	Ecomerden Ecocage	Harvested after week	79	62	No of fish harvested (from 1,000,000 input)	814,336	979,980
Performance data from Ecomerden 2017													
	Control, open cage	Ecomerden Ecocage											
Harvested after week	79	62											
No of fish harvested (from 1,000,000 input)	814,336	979,980											

	Survival rate	81.4%	98%
	Cost NOK/kg live	25.96	20.14
	No generations per 10 year cycle	5.91	7.54
IP	Norway Patent Application 20110254 (Granted) "Merdkonstruksjon" – A closed containment structure for fish farming...		
	Norway Patent Application 20161461 (Pending) "Inntaksfilter" – intake filter		

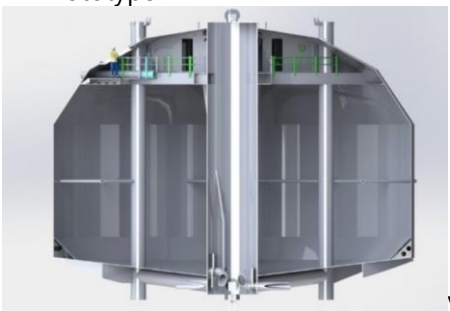
System:	Fishglobe	
Company:	Fishglobe AS	
Company details:	Formed in 2013 specifically to develop and exploit FishGlobe technology, but had roots in 1980s with experimental concrete closed containment system.	
Development company/partners	Main partner of cntrlAQUA	
Closed containment technology:	<p>PE globe with a strong and stiffened structure. The concept is a robust system with a totally controlled internal environment and flexibility of operation and application. The company consider that their globes may replace many functions of well boats for treatments as well as providing culture volume.</p> <p>The dome of the spherical structure includes room for all the technical equipment, separate feed storage and the potential for emergency power for pumps.</p>	
Images:	<div style="display: flex; justify-content: space-around; align-items: flex-start;"> <div style="text-align: center;">  <p>V2 Prototype</p> </div> <div style="text-align: center;">  <p>V3 R&D</p> </div> <div style="text-align: center;">  <p>V5 postsmolt</p> </div> </div> <div style="text-align: center; margin-top: 20px;">  <p>V5 section</p> </div>	

<p>Proposed Product Range</p>	<p>Products</p> <div style="display: flex; justify-content: space-around; align-items: flex-start;"> <div style="text-align: center;">  <p>FishGLOBE V3 R & D</p> <p>Size: 80 cbm Capacity: 5 tons of fish Diameter / height: 5 m</p> <p>Usage: R & D location, seawater Broodstock, freshwater Fingerlings, freshwater Cleaner-fish</p> </div> <div style="text-align: center;">  <p>FishGLOBE V4 Fingerlings</p> <p>Size: 600 cbm Capacity: 50 tons of fish Diameter / height: 11 m</p> <p>Usage: R & D location, seawater Broodstock, freshwater Fingerlings, freshwater Fingerlings, seawater Cleaner-fish</p> </div> <div style="text-align: center;">  <p>FishGLOBE V5 Postsmolt</p> <p>Size: 3 500 cbm Capacity: 250 tons of fish Diameter / height: 19 m Hs > 1,7 m / >1,25 m/s</p> <p>Usage: Postsmolt Treatment Freshwater Treatment Slaughter cage</p> </div> <div style="text-align: center;">  <p>FishGLOBE V6 Fish farming</p> <p>Size: 29 000 cbm Capacity: 2 000 tons of fish Diameter / height: 35 m Hs > 1,5 m / >0,85 m/s</p> <p>Usage: Fish farming</p> </div> </div> <p>V3 and V4 have been extensively tested. V5 is ready for use. The proposition is that even the smaller units may have useful applications.</p>
<p>Operation details:</p>	<p>V5 is proposed for financially-viable rearing of post smolts to 1,000g. It has a volume of 3,500m³, and a diameter of 19m. It is claimed it will accommodate 250t of fish.</p>
<p>Performance data:</p>	<p>Little data is available. According to the company "The FishGLOBE V4, which has a capacity of 70 m³, has been tested with good results. "It shows itself to be very robust, can withstand waves and currents very well. The patents have been tested in practice and work as expected. The results showed that it needed some design work to improve ballasting. Those improvements have now been completed for FishGLOBE.5".</p>

Intellectual Property/other	<p>2 Patents have been found in Espacenet (possibly the same):</p> <ul style="list-style-type: none"> <input type="checkbox"/> 1. Fremgangsmåte ved transport av fisk inn i og ut av lukket tank <input type="checkbox"/> 2. CLOSED TANK FOR FISH FARMING AND METHOD FOR TRANSPORTING FISH INTO AND OUT FROM SUCH TANK
Other	<p>From the company website:</p> <p>"Testing</p> <p>Our sister company RyFish has been assigned a FOU license of 1 MTB (780 tons) for a period of five years. This means that we can produce 1,500 tons a year in 3 of our FishGLOBE V5, size 3000 m3. This will give us the opportunity to test out full scale production in the FishGLOBE. We are grateful to Fiskeridirektoratet who after their assessment has concluded that we meet the terms and conditions for an aquaculture license for research purposes."</p>

System:	Lerøy Preline
Company:	Preline Fishfarming System AS, Lerøy Seafood Group
Company details:	Preline Fishfarming System AS is 91% owned by Lerøy Seafood Group Lerøy Seafood is a co-owner of Scottish Sea Farms
Useful websites:	Lerøy Preline , Preline
Development company/partners	
Closed containment technology:	<p>A plastic and steel superstructure supporting (eventually multiple) horizontal, PE, oval-section tube raceways in which the salmon are contained. A laminar water flow of relatively high velocity is maintained along the length of the tube with "propellers/current creators".</p> <p>The entire system is intended to be movable, so that if solid waste is discharged directly, the impact can be reduced by moving the system.</p> <p>The principle is radical in that flow velocity through the system – and hence, exercise conditions for the fish – has been a fundamental consideration of the Preline concept.</p> <p>The pilot system details are explained in detail on the Preline website (Preline3)</p>
Images:	<p>First test in small pilot</p>  <p>Superstructure - concept</p>



Concept

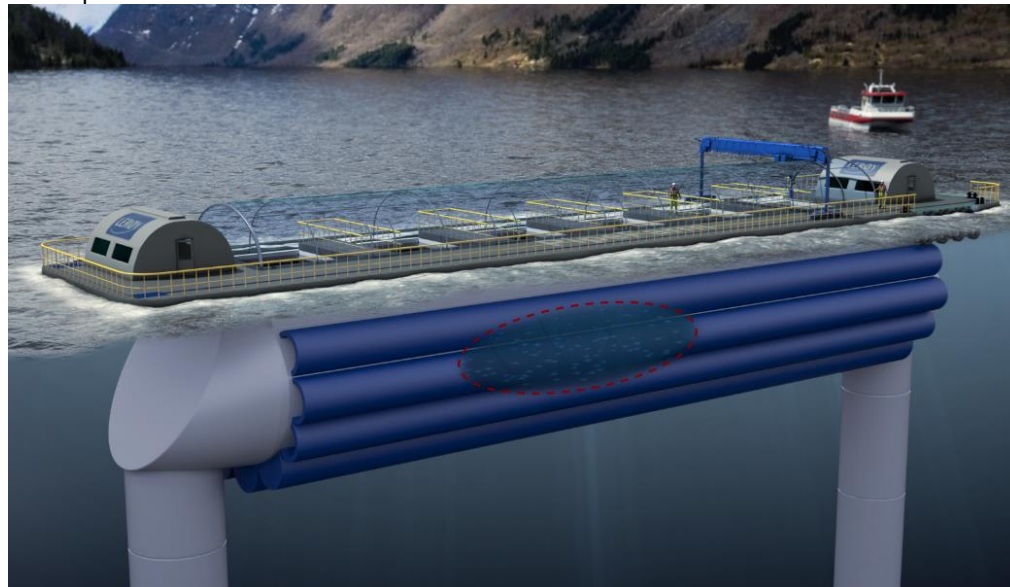

Pilot plant:



Tube:

	
<p>Operation details:</p>	<p>Volume of single raceway (pilot) – 2,000m³ Water extracted from 30m depth Water flow = 400m³/min Water current = 0.15m/s Water exchange rate = /6 min</p>
<p>Development</p>	<p>The pilot facility, launched in 2015, in Samnanger municipality (see photographs) included a single “Pipe” has a volume of 2,000 m³. By the end of 2017, six batches of smolts had been produced in the system.</p> <p>The second phase will incorporate many modifications, based on the experience of the initial pilot, and will have double the culture volume.</p> <p>In January 2018, Lerøy Seafood was granted only one of the nine development licences it had applied for (Preline2018)</p>
<p>Performance data:</p>	<p>The pilot has been seeded with batches of ~160,000 smolts. Mortality and lice infestation have been significantly better than controls. Growth rates have also exceeded controls on two occasions – in the third, the effect of temperature differences between the surface (control) and intake depth led to no significant growth improvement.</p>
<p>Cost data (from Preline2018)</p>	<p>Originally Lerøy wanted to develop and test the Pipe Farm in three different locality types - sheltered fjords, open coastal waters and the Arctic. The nine licences applied for were to be divided evenly between locality types. Because of the different degree of exposure to environmental loads, the Pipe Farms planned for the different areas are not identical.</p>

	<p>From an economic point of view, it would according to the calculations cost between NOK 77 million and NOK 91.4m to build two units in one locality. By building just one device, the cost will be NOK50-60m. This is for a 450t biomass system.</p>
<p>Intellectual Property/other</p>	<p>Norway Patent Application 20111316. Granted.</p> <p>WO 2013048259 (A1) – Fish farming plant, module, method and use. The present invention relates to a fish farming plant (1) adapted for floating in free water. The plant comprises a substantially vertical inlet pipe (3) and a corresponding outlet pipe (4) for taking in and discharging water, respectively, at a water depth having the desired water quality at a depth (h). A substantially horizontal residential compartment (30) of an accommodation assembly (2) has an inlet end and an outlet end. Lattices (7, 8) are provided at these ends. Also provided at said ends are angled end sections for connecting the inlet pipe (3), outlet pipe (4), and residential compartment (30). The plant also comprises at least one means for providing water flow through the residential compartment (30). The invention further includes a module for a residential compartment of a fish farming plant, a method for manufacturing an accommodation assembly (2), use of such a fish farming plant (1) for smolt, as well as a method for emptying such a fish farming plant (1).</p>

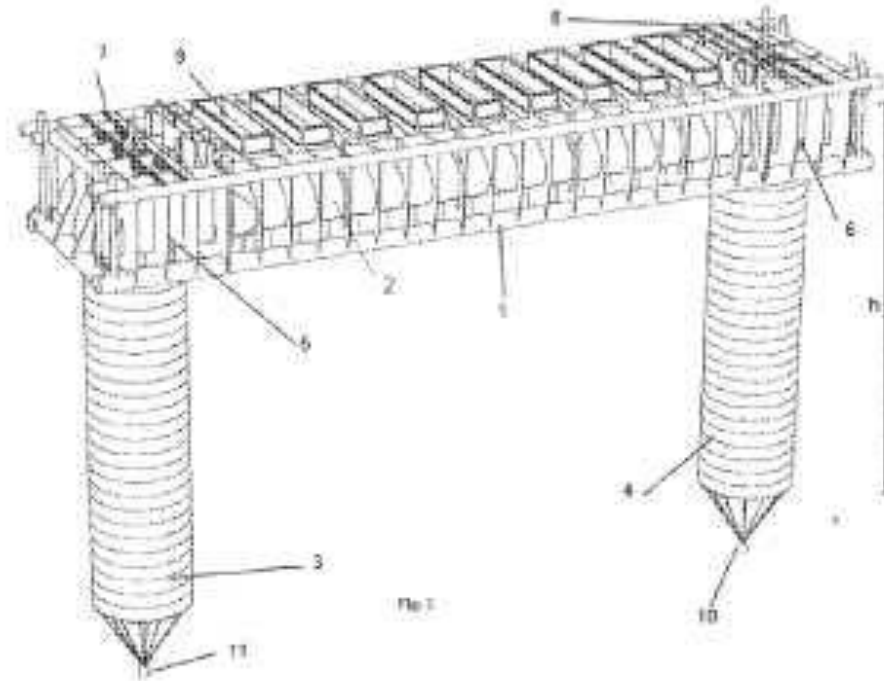

From an Espacenet patent search ([PrelineEspacenet](#)), three patents/patent applications were found:

- 1. **FISH FARMING PLANT, MODULE, METHOD AND USE**
- 2. **CONTAINER FOR FISHFARMING**
- 2. **CONTAINER FOR FISHFARMING**

System:	Salmon Home No 1
Company:	PHP Innovation (Per Helge Pedersen), Fishfarm Innovation , Nekton Havbruk AS (wholly owned by Smølen Handelskompani AS)
Company details:	Not entirely clear. PHP and Fishfarm Innovation are both small technology companies; Nekton Havbruk was originally engaged in cod farming but in the last 6 years has been involved in various closed containment projects with multiple partners.
Useful websites:	
Development company/partners	Betonmast (major engineering company) – manufactured concrete structures.
Closed containment technology:	<p>Floating lightweight reinforced concrete tank. The trial tank has a volume of 1,000m³ and was stocked with 60,000 smolts to be grown to 500g. The intended full scale unit will be 5,000 m³ and will be arranged in a concrete deck Video of trial system launch. The walls contain voids in which plant and pipes can be located.</p> <p>The total wall thickness is 800mm including a 500mm wide void. (Translation from the website): “We have considered both using concrete injection technology and a more traditional formwork method. We have chosen to produce the pilot tank by pouring the bottom of the tank first to build a circular screed for the walls. The thickness of each of the walls is only 15 cm! There is thus a double wall of fluid in the middle. Total wall width will be 80 cm! This means that we get a solid walkway on top of the tank. Inside the walls there are pipes, pumps and tanks. With the help of SKB concrete and fiber we will get the strength we need. To ensure sufficient buoyancy we put in liquid substances (isopropanol). We also build reinforcements in mind in relation to anchoring. There are six concrete pillars in the tank that tie the two walls together.”</p> <p>According to this report the gross weight of the tank is 250t.</p> <p>Trial tank appears to be ~ 8m deep and 12m diameter. Implied stocking density at 500g = 30kg/m³.</p> <p>The tank appears to have in-built vertical channels and pumps contained within the wall voids which</p>

Images:





Constructing the 'Salmon Home No1'.

Image: Fishfarming Innovation

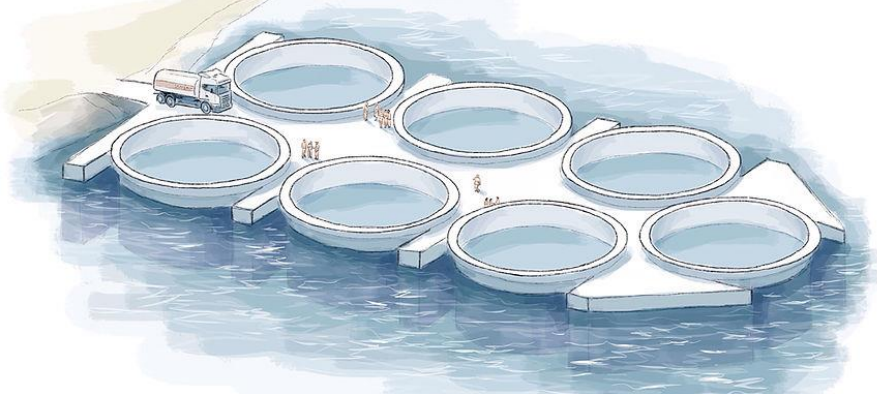

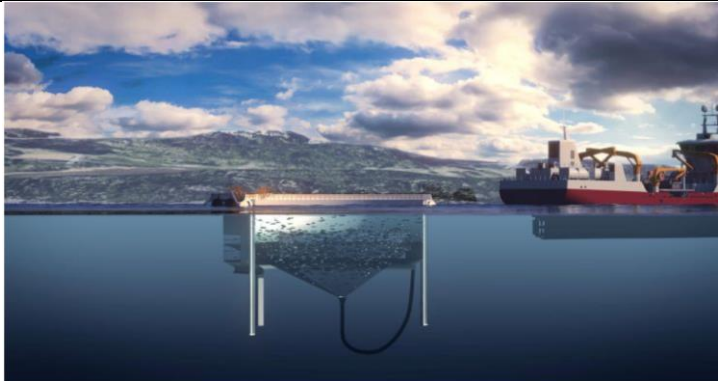
	
Status/licences:	Trial system launched June 2016.
Other:	Origins in 2010 at a seminar under auspices of Norwegian Concrete Association.
IP	No patents found

System:	Aquatraz
Company:	The cage has been designed by the firm Seafarming Systems Ltd and is owned and operated by Midt-Norsk Havbruk
Company details:	
Associated Company	Seafarming Systems AS is part of a regional aquaculture cluster "Aqua Technology" in the Stavanger area. The cage is built at the Fosen shipyard at Kvithylla in Trøndelag
Useful websites:	http://aqua-technology.no/projects/aquatraz/ https://www.seafarmingsystems.com/ https://www.fishfarmingexpert.com/article/180000-fish-placed-in-first-aquatraz/ https://mnh.no/
Development company/partners	
Closed containment technology:	A net pen which is semi-enclosed within a steel wall which can be raised and lowered as needed for operational purposes.
Images:	

	
<p>Development</p>	<p>Pilot cage system has been installed at the Eiterfjord site in Nærøy municipality and was stocked with 180,000 fish weighing just under 1.5 kg.</p>
<p>IP</p>	<p>Seafarming Systems Ltd, have been granted three patents (Norway, Canada) (Seafarming Systems - Espacenet)</p> <ul style="list-style-type: none"> <input type="checkbox"/> 1. A FLOATING FISH FARMING PLANT AND ASSEMBLY OF PLANTS <input type="checkbox"/> 2. A FLOATING FISH FARMING PLANT AND ASSEMBLY OF PLANTS <input type="checkbox"/> 3. CONTAINER FOR USE IN WATER AND A METHOD FOR CONSTRUCTION OF SUCH CONTAINERS

Appendix Three - Summary details of proposed CCS design

This appendix provides details of floating closed containment systems which are under development, but not yet tested at realistic scale. Most information has been obtained from fish farming press publications.

System:	Egg
Company:	Hauge Aqua/ Marine Harvest
Company details:	Hauge Aqua is a small aquaculture-focused consulting engineering development company. Its activities are underpinned by the "Haugian heritage" (Christian religious principles)
Useful websites:	http://www.haugeaqua.com/ Egg Video: http://www.haugeaqua.com/Technology/
Development company/partners	Marine Harvest. "Marine Harvest has an exclusive agreement with Hauge Aqua, and the rights to the products, meanwhile Hauge Aqua owns the rights to the technology" according to MH CEO (Feb 2016)
Closed containment technology:	
Images:	
Technology:	<p>Details: 44m high, 33m wide 90% under water. Each egg will contain 1,000 tonnes</p> <p>Construction material is a composite sandwich formed in a complete seamless double curved surface. Ninety percent of the tank is submersed at all times. A central stiffens the structure vertically.</p> <p>It requires an external power supply and feed source. Inlet water is separated from the outlet; the inlets are located in the bottom of the egg; two main pumps introduce water from 20m below the egg. It flows in a circular movement to the top where it exits the tank 4 meters below surface. Water quality and volume can be controlled, ensuring steady oxygen levels and also de-gassing of carbon dioxide. The bottom entry makes sure that lice larvae do not enter the pen since salmon lice larvae natural habitat predominantly is in the top layer. The water inlet and outlet is double-secured so that escape is not possible.</p>

	The feed is from an automated system on a barge. Internal feeding automation distributes the feed at various levels in the water body. The upflowing stream allows for retention of pellets, improving availability.
Status/licences:	Marine Harvest stated (Egg2016) it was planning to invest NOK 600m in testing and developing HA's closed containment "Egg" cages (Feb 2016). It applied for 14 development licences but was awarded 4 (Egg2017). This was increased to 6, with a biomass of 4,680t (Egg2018) but delays mean that the planned construction may be delayed until 2019 (Egg2018).
Intellectual Property:	<p>NO Patent Application 20151019. Floating and submersible closed contained aquaculture farming invention. Granted 12/8/15. WO 2017026899A1 (Patent see https://patents.google.com/patent/WO2017026899A1/en)</p> <p>NO Patent Application 20170300, Floating and submersible closed contained aquaculture farming invention. Pending</p> <p>Espacenet search ("Hauge Aqua"):</p> <ul style="list-style-type: none"> <input type="checkbox"/> 1. Floating and submersible closed-contained aquaculture farming, and method of rearing fish <input type="checkbox"/> 2. Floating and submersible closed-contained aquaculture farming invention

<p>System:</p>	<p>Salmon Zero</p>
<p>Company:</p>	<p>Eide Fjordbruk</p>
<p>Company details:</p>	<p>Eide Fjordbruk is a long-established fish production company.</p>
<p>Concept:</p>	<p>Salmon Zero was the brainchild of Erland Eide, developed in a master's thesis. The concept is a land-based RAS with floating concrete tanks.</p>
<p>Images</p>	
<p>Video</p>	<p>Concept Video (in English)</p>
<p>Other</p>	<p>SalmonZero2017a – (translated as) SalmonZero2017b</p>
<p>IP</p>	<p>None found</p>

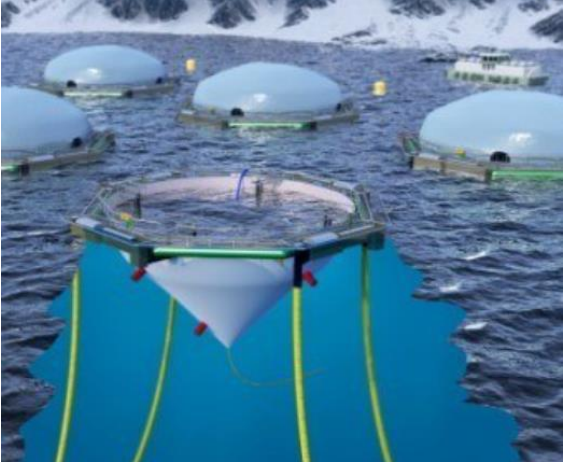
System:	FlexiFarm
Company:	Flexifarm appears to be a project, rather than a corporate body, and partners on the project are Cermaq Group AS , Botngaard System , Xylem and Serge Ferrari
Company details:	HQ Oslo. In 2014 acquired by Mitsubishi Corp, delisted from OSE; 2013 sold Ewos
Useful websites:	Company Press release 11/17
Development company/partners	Developed by Cermaq together with Botngaard System , Xylem and Serge Ferrari
Closed containment technology:	Conical flexible membrane. Also, treatment of all inlet water. "In FlexiFarm, the inflow of water will first be filtered and then treated by UV-light to prevent intake of lice, algae, bacteria, and virus." (Flexifarm2017b).
Images:	
Technology:	Flexible membrane, 4 deep pumped inlets. UV treatment of inflow. Can grind and spread sludge to avoid point loads underneath sites. Discharge of organic material can be adapted to the capacity of the area Also has possibility to collect the sludge. Discharge passed through a filter where sludge is collected and transported to shore for further processing.
Status/licences:	Reported 11/2017 "Cermaq seeking 13 Flexifarm development licences"
Other:	"It is a major goal for the development of FlexiFarm that investment and operation cost will remain low, and that the

	anticipated effect will ensure that production cost per kg salmon is reduced," Magnus Stendal, GM Botngaard System AS. NB this seems to be Cermaq's system of choice following long development process with AquaDome.
Intellectual Property	None found

System:	Hydra Pioneer/Hydra salmon
Company:	Hydra Pioneer AS
Company details:	Hydra Pioneer AS is a wholly owned subsidiary of Hydra Salmon AS
Associated Company	Kvarv AS (financial backer)
Useful websites:	No company websites
Development company/partners	
Closed containment technology:	It is an open steel tank which is 20 metres deep and has a diameter of 60 metres. The top part of the cylinder is fitted with a lid and attached to a floating ring which keeps the construction protruding slightly out of the water. The bottom of the cylinder will be made of a metal mesh or plastic grid, allowing water to be replaced naturally. Beneath the lower cylinder a sub-section fitted with blade-like vanes naturally circulate water in the tank. It is designed to withstand wave heights of up to 3-4 metres.
Images:	 <p>Hydra Pioneer's new design. Image: Hydra Pioneer.</p>
Development	According to this report (HydraPioneer2017) the concept was developed with a 1/40 model at SINTEF which

	<p>showed good results in strong currents. It is designed to withstand wave heights of 3-4m. The company applied for 4 development licences with a total capacity of 3,120 of salmon. According to this report (HydraPioneer2018) the company's application was approved in April 2018 and the company intend to go ahead with the first tank at a cost of EUR31.2m. The Fisheries Directorate stated that, "it has no reason to doubt Kvarv's ability to finance the project's earmarked investments".</p>
IP	<p>Hydra Pioneer AS has been granted a Norwegian patent:</p> <ul style="list-style-type: none"> <input type="checkbox"/> 1. PRODUCTION-TANK

Appendix Four – Norwegian “Green” and “Development” Licences

In November 2012, the Norwegian government announced a novel system of allocating 45 new licences representing additional biomass of about 55,000t. According to Government Minister Lisbeth Berg-Hansen, the aim was to stimulate the development of technical solutions to drive positive change in the industry (Undercurrent News 2012). Applications were judged on the basis that proposals for the licence needed to demonstrate significant changes in farming systems or practices in order to address the challenges of sea lice and escapes. 35 of the licences were offered with the condition that an existing licence would also be converted to the proposed “green” technology with the net result that there would be 80 new green licences.

Production companies typically paid about NOK60m for each licence (undercurrent News 2014).

The scheme was followed in 2016 with a new Norwegian Government initiative referred to as “Development licences”. The scheme was designed to address the growth limitations of the Norwegian industry – namely sea lice, fish escapes and shortage of coastal acreage (Norwayexports.no 2016). In November 2015, the Norwegian Ministry of Fisheries and Coastal Affairs announced it would grant free development concessions for up to 15 years for projects promoting technology that can solve the environmental and acreage challenges facing the aquaculture sector. If the project fulfils a set of fixed criteria, the licence could be converted into commercial licenses at a cost of NOK 10 million, significantly below the typical commercial rate of NOK 50-60 million.

Applications for development licences were open for the two years to November 2017. 104 applications have been made for 898 licences. A single licence would represent 780t of allowable biomass. The applications are taking some time to consider but represent the full range of novel systems including open-ocean systems and closed containment nursery systems.

Appendix Five - Sea lice treatment cost calculations

Calculations for Emamectin Benzoate Active Ingredient Cost:

First seven months cost per treatment = 0.246 £/g x 149 g/treatment = £36.6/treatment

Remaining time cost per treatment = 0.246 £/g x 421 g/treatment = £103.4/treatment

Calculation of Deltamethrin Active Ingredient Cost:

$$22 \frac{\text{NOK}}{\text{mL}} \times 0.092 \frac{\text{£}}{\text{NOK}} \times \frac{\text{mL}}{10 \text{ mg}} \times 1000 \frac{\text{mg}}{\text{g}} = 202.4 \frac{\text{£}}{\text{g}}$$

First seven months cost per treatment = 202.4£/g x 96 g/treatment = £19,445.6/treatment

Remaining time cost per treatment = 0.246 £/g x 99 g/treatment = £20,134.6/treatment

Calculation of Azamethiphos Active Ingredient Cost:

First seven months cost per treatment = 1.75 £/g x 1490 g/treatment = £2603.6/treatment

Remaining time cost per treatment = 0.246 £/g x 2124 g/treatment = £3711.3/treatment

Calculation of Hydrogen Peroxide Active Ingredient Cost:

1500ppm/L -> 0.0015 L H₂O₂ per L treatment volume.

100m circumference cage cinched to 2.5 m deep (SSF Treatment Protocols) = treatment volume of appx 2,000 m³ (2,000,000L)

2,984L H₂O₂ required @ 6.164 £/L = £18,395/treatment

Example Calculation: Number of Treatments Required (e.g. Emamectin Benzoate)

Emamectin Treatments Required (Conventional Cycle)

= 7 months x Treatment frequency (first 7 months)

+ 13 months x Treatment frequency (remaining culture time)

= 7 months x $\frac{0.27 \text{ treatments}}{\text{month}}$ + 13 months x $\frac{0.10 \text{ treatments}}{\text{month}}$

= 3.18 treatments in one traditional cycle

Emamectin Treatments Required (Nursery Cycle)

= 13(remaining culture time) months x Treatment frequency

= 13 months x $\frac{0.10 \text{ treatments}}{\text{month}}$ = 1.3 treatments in one nursery cycle

Emamectin Treatments Required (Nursery Cycle with 20% reduction in lice)

= 13(remaining culture time) months x Treatment frequency x 0.8

= 13 months x $\frac{0.10 \text{ treatments}}{\text{month}}$ x 0.8 = 1.04 treatments in one nursery cycle

Example Calculation: Total Cost of Medicinal Treatments (e.g. Conventional Cycle)

Total Cost of Medicinal Treatments

$$\begin{aligned}
&= \text{Cost per medicinal treatment} \times \sum \text{Chemical Treatments Required} \\
&= £55,200 \times (\text{Deltamethrin Treatments} + \text{Azamethiphos Treatments} \\
&\quad + \text{Emamectin Treatments}) = £55,200 \times (2.17 + 3.01 + 3.19) = £55,200 \times 8.38 \\
&= £462,800
\end{aligned}$$

Cost of Medicinal Treatments per kg (e.g. Conventional Cycle)

$$= \frac{\text{Medicine treatment cost per cycle}}{\text{Total production per cycle from 2500 tonne site}} = \frac{£462,800}{4,000,000 \text{ kg}} = 0.11 \text{ £/kg}$$

Example Calculation: Cost of Non-medicinal Treatments Required (e.g. Conventional Cycle)*Cost of Hydrogen Peroxide Treatments*

$$\begin{aligned}
&= \text{Number of Hydrogen Peroxide Treatments} \times \text{Cost per treatment} \\
&= 0.56 \times \text{Number of Medicinal Treatments Required} \times £86,400 \\
&= 0.56 \times 8.38 \times £86,400 = £405,655
\end{aligned}$$

Cost of Mechanical Treatments = Number of Mechanical Treatments x Cost per treatment

$$\begin{aligned}
&= 0.49 \times \text{Number of Medicinal Treatments Required} \times £102,600 \\
&= 0.49 \times 8.38 \times £102,600 = £421,500
\end{aligned}$$

Cost of Cleaner Fish Treatment

$$\begin{aligned}
&= \text{Total Salmon Cultured} \times \% \text{ Of Cleaner Fisher Required} \times \text{Cost per cleanerfish} \\
&= 1,000,000 \times 10\% \times £2.16/\text{fish} = £216,000
\end{aligned}$$

Example Calculation: Total Treatment Cost and Total Cost/kg (e.g. Conventional Cycle)**Total Cost of Medicinal Treatments per cycle**

$$\begin{aligned}
&= \text{Medicinal Treatment Cost} + \text{Hydrogen Peroxide Treatment Cost} \\
&\quad + \text{Mechanical Treatment Cost} + \text{CleanerFish Cost} \\
&= £462,800 + £405,655 + £421,500 + £216,000 = £1,505,955
\end{aligned}$$

Total Cost of Treatments per kg (e.g. Conventional Cycle)

$$= \frac{\text{Total Cost of Medicinal Treatments per cycle}}{\text{Total production per cycle from 2500 tonne site}} = \frac{£1,505,955}{4,000,000 \text{ kg}} = 0.38 \text{ £/kg}$$

Appendix Six - Wastewater Treatment Equipment Descriptions

Rotary Drum

Rotary drum filters are rotating drums equipped with a fine mesh screen which sieve particles larger than their screen size out of the waste stream. Screened water exits the drum and solids are retained on the screen until they are removed intermittently or continuously via hydraulic flushing and sent on for further treatment (which provides a waste stream with 1-6% TS) (Metcalf & Eddy Inc. 2004; Summerfelt 1999). In aquaculture, rotary drums are attractive because they can remove solids from large volumes of flow while taking up a small footprint, although they do have associated operating and maintenance costs (Summerfelt 1999). Sieve sizes of 60-100 μ m are typically used in aquaculture applications, with negligible benefits and higher maintenance costs being associated with sieves below 60 μ m (Cripps and Bergheim 2000). The RD considered for this application would have a max flow capacity of 52m³/day (average flow of 25 m³/day), use 1.0 kW for the pump and drive motor, and have an intermittent backwash flow rate of 0.9 m³/hr (NP drum filter tech specs).

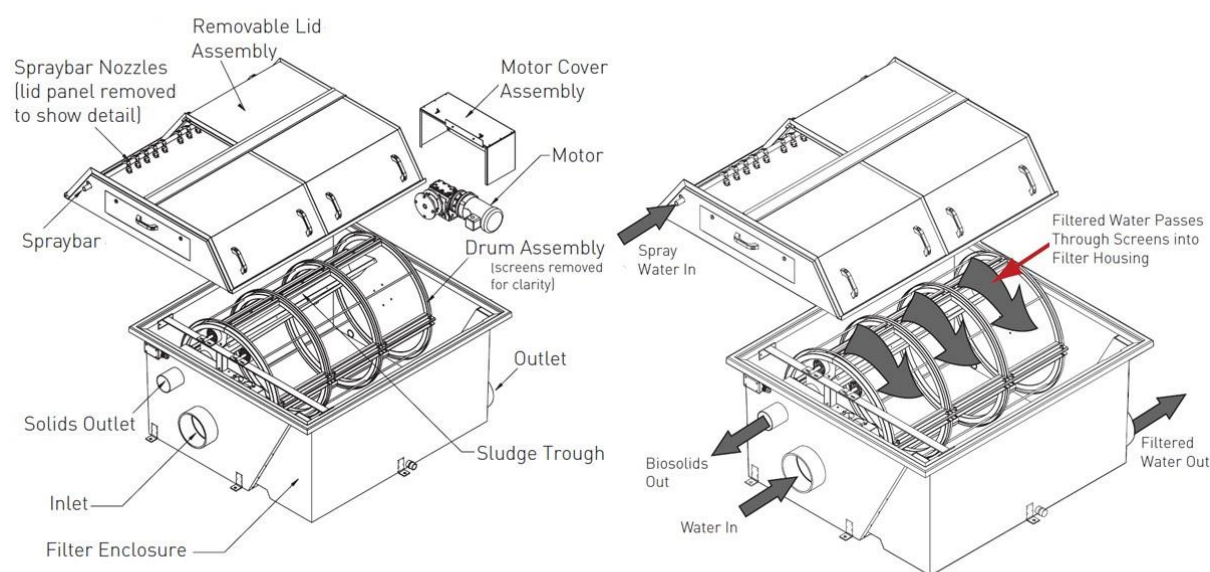

Figure A5.1: Diagram of the components and operation of a rotary drum filter. Source: Pentair 2018 (<http://paeswater.com/pr-aqua-drum-filter.html>).

Swirl Separator

In swirl filters (aka hydrocyclone, vortex separator, see Figure A2) water is injected at the side of a cone-shaped or cylindrical tank to create a flow which spins around the centre of the tank. This flow creates a centrifugal force which concentrates larger, denser particles to the bottom of the tank while clarified water leaves from outlets near the top (Metcalf & Eddy Inc. 2004; Summerfelt 1999). In aquaculture, swirl filters have the benefit of being easy to operate (i.e. no moving parts, no additional

operating cost), but their efficacy is limited attributable to the low specific gravity of aquaculture solid wastes (Summerfelt 1999).

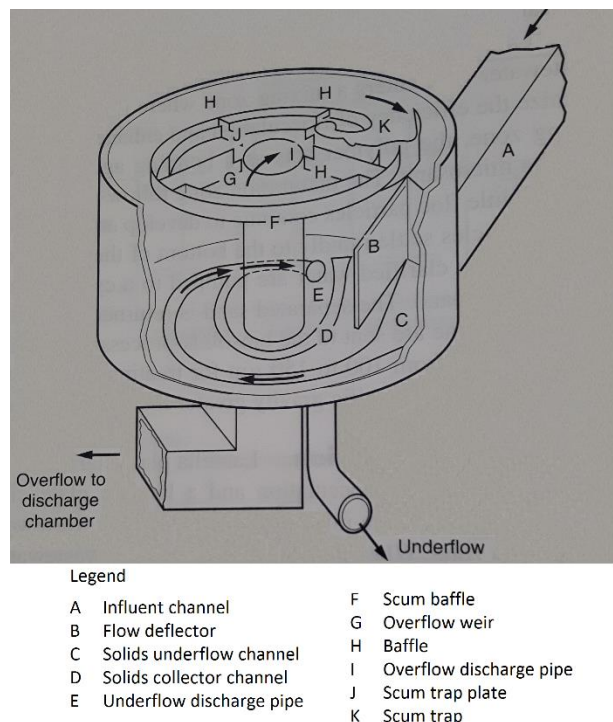

Figure A5.2: Diagram of swirl separator (aka vortex separator aka hydrocyclone) operation. Source: (Metcalf & Eddy Inc. 2004).

Decanter Centrifuge

In a decanter centrifuge slurry is fed into the rotating bowl of the centrifuge, which separates the sludge into a dense 'cake' of 10 to 30% solids and a dilute liquid 'centrate' stream which contains fine or low-density solids particles (Metcalf & Eddy Inc. 2004). The amount of solids in the centrate stream can be reduced through the addition of polymer conditioners which help the solids particles in the sludge aggregate, improving the capture percentage and removal efficiency of the centrifuge (Metcalf & Eddy Inc. 2004). The consistency of the solids cake can vary in consistency from that of custard to that of a moist soil, with higher solids percentages (>25%) being easier to handle and transport, and lower solids percentages (<15%) being transportable by pump (Metcalf & Eddy Inc. 2004; US EPA 2000a).

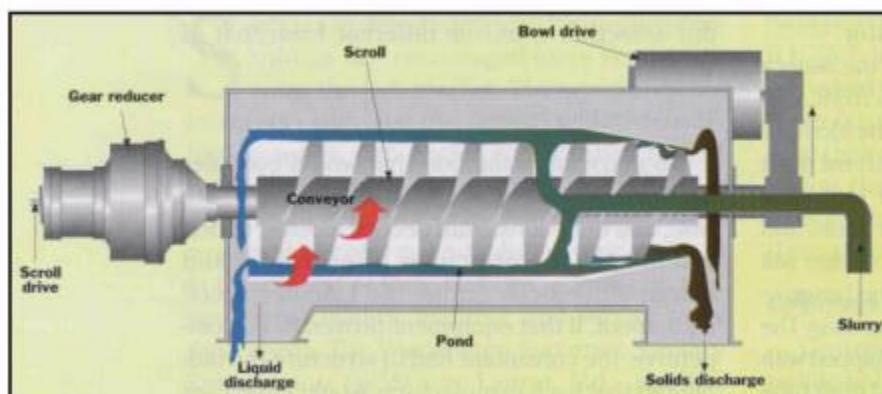

Figure A5.3: Diagram of decanter centrifuge operation. Source: (US EPA 2000a).

Septic Tank

In a septic tank (Figure A4), aquaculture waste are pumped ashore into the septic tank vessel, which would be partially buried, with only the access ports above ground (Summerfelt and Penne 2007; US EPA 2000b). The solid particles settle and form a sludge blanket at the bottom of the tank, and a scum layer (composed of low density solids, oils and grease) forms at the top of the tank (US EPA 2000b). The clarified water from near the top of the tank is discharged through a network of pipes into what is called a leaching field (aka soakaway field) and the contents of the tank are pumped out and transported via tanker to a municipal waste water treatment plant twice per year (Summerfelt and Penne 2007; Summerfelt 1999). High flow rates into the settling tanks and decomposition of solids can result in the resuspension of solids and nutrients into the clarified water of the settling tanks, which limits their treatment efficacy (Summerfelt and Penne 2007; Summerfelt 1999).

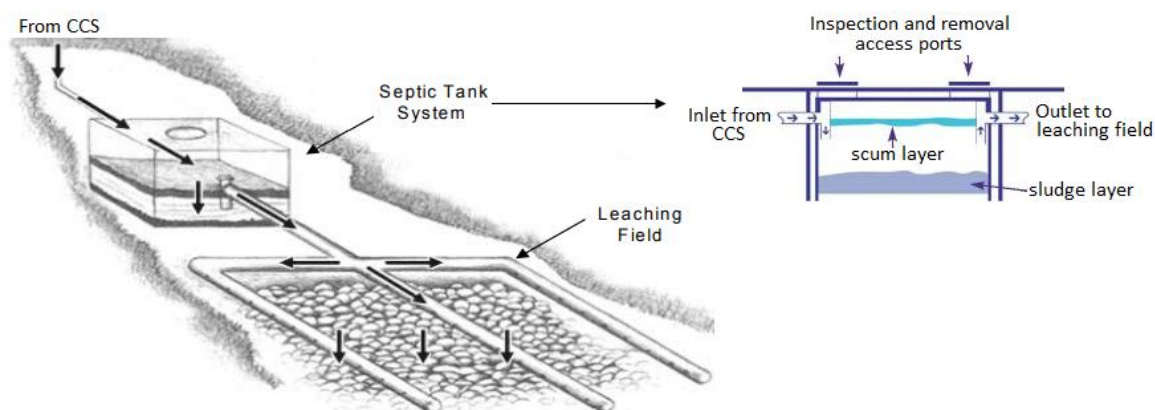

Figure A5.4: Diagram of septic tank system operation. Sources: EPA 2000b (https://www3.epa.gov/npdes/pubs/septic_system_tank.pdf) and Scottish Water 2015 (<http://www.scottishwater.co.uk/you-and-your-home/septic-tank-emptying/your-questions-answered>).

Batch Dryer

Dried solid 'cake' (20 to 30% solids) is fed into batch dryers (Figure A5), where the solids are contacted with hot, dry air. Water evaporates from the wastewater solids, creating a >80% solids product, which is transferred into the solids hopper (Watropur 2017, EPA 2006). The dried solids have a reduced volume and weight and improved stability (i.e. they can be stored for long periods of time)(Rohold 2018; US EPA 2006; Watropur 2017).



Figure A5.5: Image of Watropur Inc.'s Watromat standard batch sludge dryer. Source: <http://www.watropur.com/products/standard-sludge-dryer.html>.

Waste Incinerators

For on-site incineration, solids are top-loaded into a waste incinerator (Figure A6), and burned with a direct flame created but the burning of diesel (Addfield 2018a). Incinerators can be equipped with energy recovery systems which can capture electrical or thermal energy from the combustion of diesel and waste solids, which is then utilised on-site (Addfield 2018c).

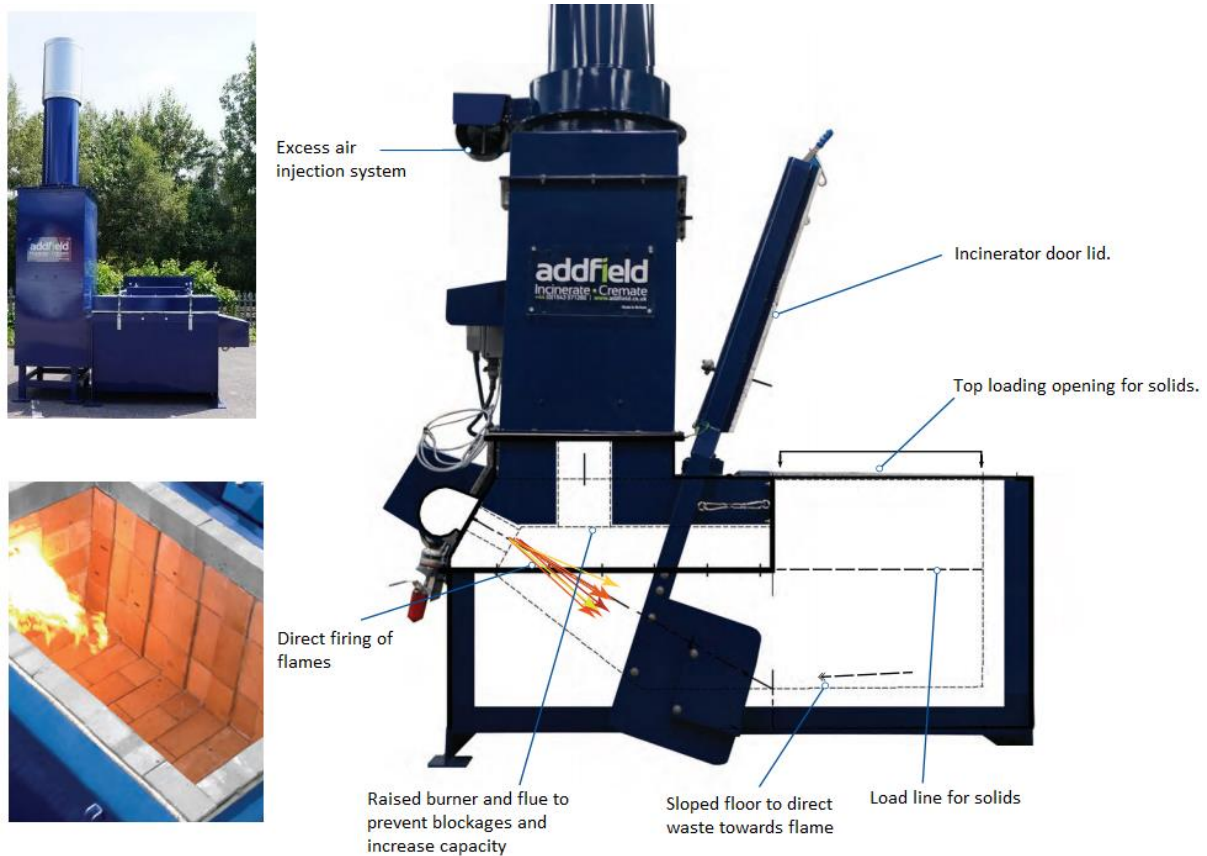

Figure A5.6: Diagram of Addfield's aquaculture waste incinerators. Modified from: <https://addfield.com/wp-content/uploads/2017/10/Thunder-500-Large-Fish-and-Aquatic-waste-incinerator-datasheet.pdf> and <https://addfield.com/machines/fish-incinerator-machine-mini-ab-aqua/>.

Appendix Seven – The growth model used for all calculations

A deterministic model was developed to predict the growth and waste production in a sea-based CCS nursery system for post-smolts grown from 100g to approximately 1,000g, as production statistics (i.e. detailed S-CCS nursery growth studies) were not available.

The capacity and operating specifications of appropriate waste-handling equipment were inferred from the waste volume production rate predicted by the growth model. Appropriate commercial units were identified, an LCA was completed and models were developed to determine operating and capital costs and to assess environmental impact. Through consultation with SEPA, regulatory costs and requirements were determined. A conceptual diagram of the model is shown in Figure A6.1.

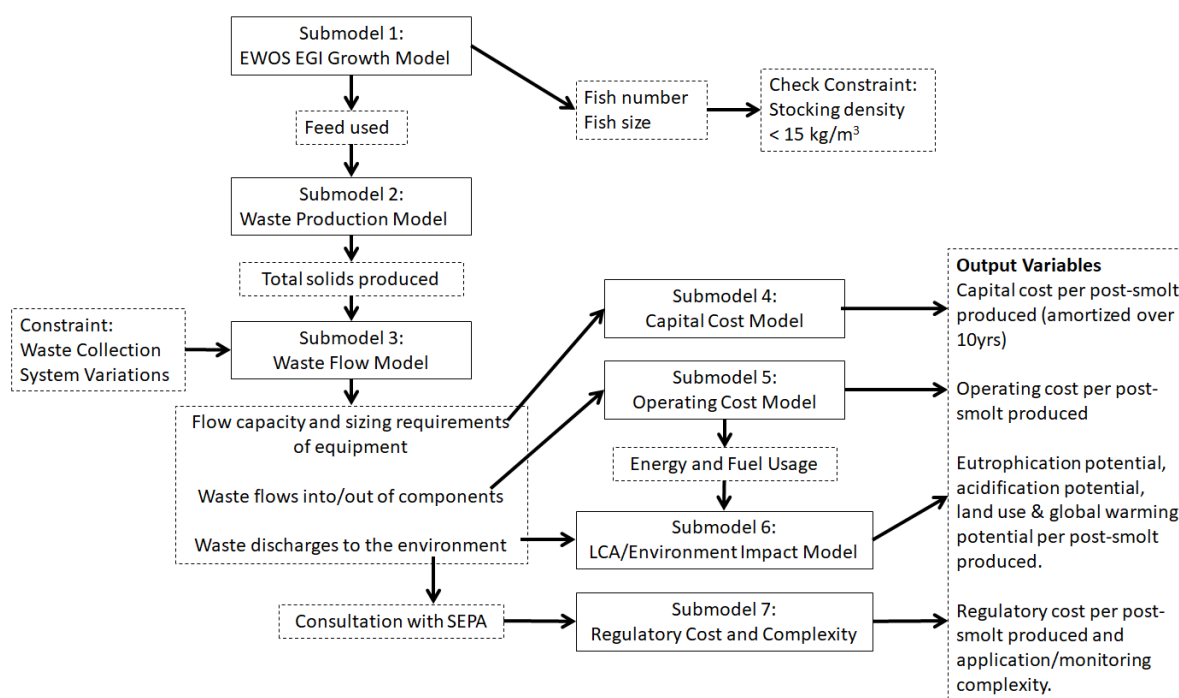

Fig A6.1 : Conceptual diagram of submodels used to determine the capital cost, operating cost and environmental impact of waste collection and disposal for one CCS nursery cycle. NB Submodel 6 is not included in this study.

The baseline (BL) case for the model was a 6,000m³ system with a maximum allowable stocking density of 15 kg/m³, operating at a latitude of 56.82 (eg Fort William) for one nursery cycle stocked with 100g smolts on April 1st (Q2 deployment). It was assumed that harvesting began once the smolts reached a mean weight of 1,000 ± 75g, and took one week to complete.

The EWOS EGI Model was used to determine fish growth rate (hence average body weight at weekly intervals throughout the cycle) and feed required over the course of the nursery cycle. All further modelling (other growth models, waste production and collection models, operating and capital cost models and LCA) and analysis were completed using Microsoft Excel 2013. Using the average monthly temperature data for depths <math>< 30\text{m}</math> obtained from a long-term monitoring centre at Loch

Ewe (Marine Scotland 2013), three different growth models were used to estimate the time and feed required for post-smolts to grow from 100g to 1000g in a CCS nursery. The growth model parameters, representative values, ranges and sources can be found in Table A6.1.

Table A6.1: Growth model parameters, representative values, ranges and sources.

Assumption	Baseline value	Range	Sources
Nursery phase input size	100g*	50 – 150g **	*(Jeffery et al. 2015) **author's assumptions
Nursery phase output size (final goal weight)	1000g ± 75g*	500 – 1500 g	(Botngaard 2018a; Jeffery et al. 2015) *author's assumptions
FCR _b for 100g – 1000g	1.05	1.00 – 1.10	(Jeffery et al. 2015)
Min/Max/Avg Temps	7.6°C 13°C 10.2°C	6.6-7.6°C 13-15.6°C 10.2-11°C	(Marine Scotland 2013; World Sea Temperatures 2018)
Thermal Growth Coefficient	2.4	2.4 – 2.7	(Thorarensen and Farrell 2011)
Mortality	4%	2 – 8%	(Ecomerden 2016; Jeffery et al. 2015; Ramsden 2017a)
Stocking density (smolt input #)	15kg/m ³ (94,000)	10 – 75 kg/m ³ (62,600 – 467,750)	(Calabrese 2017; Jeffery et al. 2015; RSPCA 2018)
CCS Unit Size	6000m ³	3500 – 21000m ³	(AkvaDesign 2014; Aquafarm Equipment 2018; Ecomerden 2016; Fish Globe 2018)
CCS Fallow Time	1 month	NA	(Ramsden 2017)

For the thermal growth coefficient model (Equations 2 and 3) and the specific growth rate model (Equations 4, 5 and 6) W_2 is fish weight (in g) at time = t_2 , W_1 is fish weight (in g) at time = t_1 , TGC is the thermal growth coefficient, Δt is time interval between t_1 and t_2 (in days), T is the temperature (in °C), FR is the feed rate (in kg feed/fish/day), FCR_b is the biological feed conversion ratio (in kg feed/kg growth), and SGR is the specific growth rate (in kg fish weight increase/fish/day) (Jobling 2003; Thorarensen and Farrell 2011).

Thermal Growth Coefficient Model

$$W_2 = \left(\sqrt[3]{W_1} + \left[\left(\frac{TGC}{1000} \right) \times (T \times \Delta t) \right] \right)^3 \quad (1)$$

$$FR = \frac{(W_2 - W_1) \times FCR_b}{1000} \quad (2)$$

Specific Growth Rate Model

$$W_2 = \exp \left[\frac{SGR}{100} \Delta t + \ln W_1 \right] \quad (3)$$

$$SGR = 0.9 T^{0.97} W_1^{-0.34} \quad (4)$$

$$FR = \frac{SGR}{100} \times FCR_b \times \frac{W_1}{1000} \quad (5)$$

The parameter entry interface for the EWOS EGI model, with baseline parameters entered, is shown in Figure 3a. For the baseline model, the city selected was Fort William (Latitude 56.82), the start date was 01/04/2002 (Q2 deployment), the start number was 94,000, mean start weight (in g) was 100, mortalities % was set to 5 (which gave a cumulative mortality of 4.15% up to 1000g), EGI was 100, ETI was 128 (giving an $FCR_b = 1.05$ up to 1000g), the minimum temperature was 7.6°C, maximum temperature was 13.0°C, and the average temperature was 10.2°C.

(a)

(b)

Company Name		Farm Name		Origin		Date									
University of Stirling		BL CCS-6000m3		NA		04/07/2018									
Temperature			Latitude	Start Date	Start		NOTE: Light blue cells should not be changed. If they need to be updated press the 'New Plan' button								
Min	Average	Max			Number	Meanw.									
7.6	10.2	13.0	56.82	#####	94,000	100.0									
New Plan				EGI	EFI	Total Morts									
				100	128	5%									
Date	Week no.	Number	Meanw.	Temp.	Growth	EFI	SGR	SFR	TGC	FCR	Feed (Kg)	Acc.Feed	# Morts	Bm. Morts	FeedType
01/04/2002	14	94,000	100.0	8.4	5.72	128	0.80	0.73	1.43	0.92	492	492	94	9.4	EWOS
08/04/2002	15	93,906	105.7	8.7	6.42	128	0.85	0.78	1.50	0.92	556	1,048	94	9.9	EWOS
15/04/2002	16	93,812	112.1	8.9	7.21	128	0.89	0.83	1.57	0.93	628	1,676	94	10.5	EWOS
22/04/2002	17	93,716	119.4	9.2	8.10	128	0.94	0.86	1.64	0.94	710	2,386	94	11.2	EWOS
29/04/2002	18	93,624	127.5	9.5	9.12	128	0.99	0.94	1.71	0.94	805	3,191	262	35.9	EWOS

The model generates weekly outputs of various parameters (e.g. SGR, TGC, FCR), the most relevant to this application being the fish number, mean weight, and mass of feed used (see Figure 3b). EWOS EGI models were run with a range of parameters in order to evaluate the model's sensitivity and to determine the differences in growth outcomes and waste generation for a variety of possible scenarios (varying FCR, mortality, start weight, deployment date, stocking density, water temperature and deployment environment). The entry values for these models are listed in Table A6.2.

Table A6.2: Parameter inputs for different EWOS EGI growth models.

Model ID	Temperatures °C			Model Starting Values						
	Min	Average	Max	Latitude	Start Date	Number	Mean Wt	Mortality	EFI	EGI
FCR = 1.05	7.6	10.2	13	56.82	Q2 – Apr 1	94,000	100	5%	128	100
EWOS EGI BL	7.6	10.2	13	56.82	Q2 – Apr 1	94,000	100	5%	110	100
FCR = 1	7.6	10.2	13	56.82	Q2 – Apr 1	94,000	100	5%	121	100
FCR = 1.1	7.6	10.2	13	56.82	Q2 – Apr 1	94,000	100	5%	134	100
2% Morts	7.6	10.2	13	56.82	Q2 – Apr 1	94,000	100	2.5%	128	100
8% Morts	7.6	10.2	13	56.82	Q2 – Apr 1	94,000	100	10%	128	100
50g start wt	7.6	10.2	13	56.82	Q2 – Apr 1	94,000	50	5%	128	100
125g start wt	7.6	10.2	13	56.82	Q2 – Apr 1	94,000	125	5%	128	100
Q1 Start	7.6	10.2	13	56.82	Q1 – Jan 1	94,000	100	5%	128	100
Q3 Start	7.6	10.2	13	56.82	Q3 – July 1	94,000	100	5%	128	100
Q4 Start	7.6	10.2	13	56.82	Q4 – Oct 1	94,000	100	5%	128	100
SD 10 kg/m ³	7.6	10.2	13	56.82	Q2 – Apr 1	62,600	100	5%	128	100
SD 25 kg/m ³	7.6	10.2	13	56.82	Q2 – Apr 1	156,250	100	5%	128	100
SD 50 kg/m ³	7.6	10.2	13	56.82	Q2 – Apr 1	313,000	100	5%	128	100
SD 75 kg/m ³	7.6	10.2	13	56.82	Q2 – Apr 1	468,750	100	5%	128	100
Loch Ewe –Surface	7.4	10.2	13.5	56.82	Q2 – Apr 1	94,000	100	5%	128	100
Loch Ewe – Stable	8	10.2	12.4	56.82	Q2 – Apr 1	94,000	100	5%	128	100
Shetland –Surface	6.8	10.2	14.8	60.15	Q2 – Apr 1	94,000	100	5%	128	100
Ayr –Surface	6.6	11.0	15.6	55.45	Q2 – Apr 1	94,000	100	5%	128	100
Lewis –Surface	6.7	10.4	14.3	58.21	Q2 – Apr 1	94,000	100	5%	128	100
Latitude Only +	7.6	10.2	13	60.15	Q2 – Apr 1	94,000	100	5%	128	100
Latitude Only -	7.6	10.2	13	55.45	Q2 – Apr 1	94,000	100	5%	128	100
Average Temp +	8	10.6	13.4	56.82	Q2 – Apr 1	94,000	100	5%	128	100
Average Temp -	7.0	9.8	12.6	56.82	Q2 – Apr 1	94,000	100	5%	128	100
10yr model	7.6	10.2	13	56.82	Apr 1, Nov 1, 13 Aug (Repeat)	94,000	100	5%	128	100

A sequence of EWOS models was also run, assuming a 1-month fallow period between nursery cycles and covering a 10-year period, in order to predict the production capability of a sea-based CCS system over 10 years.

Appendix Eight - Sites for disposal of CCS solids

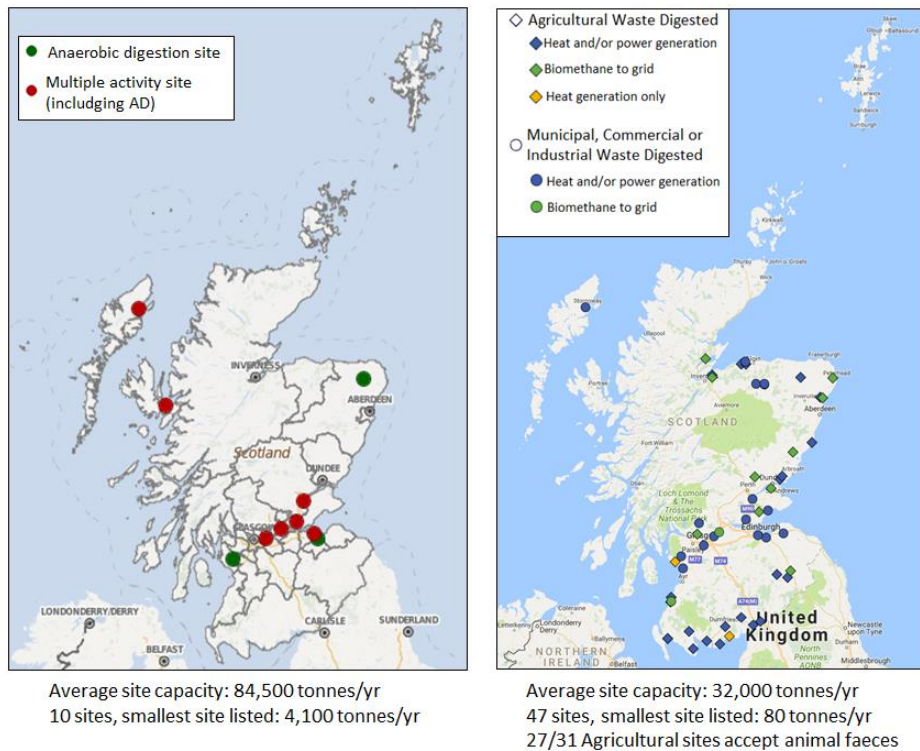
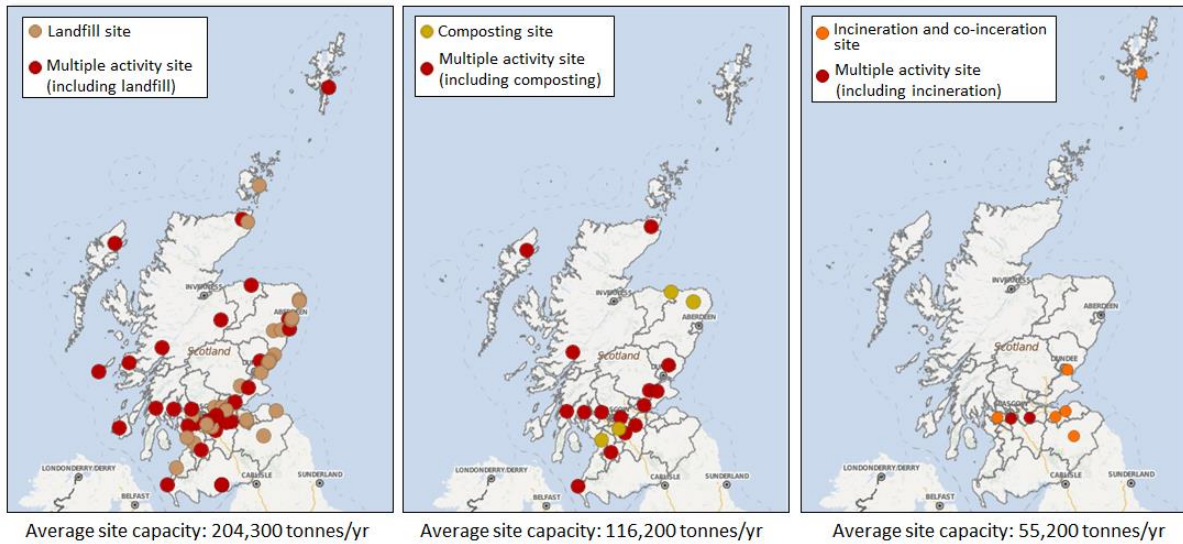

Viable sites for the disposal of CCS solids including landfill (top left), composting (top centre), incineration (top right) and anaerobic digestion facilities (bottom) from SEPA’s waste sites and capacity data tool, 2015 & NNFFC’s Biogas Map (2018). The SEPA tool lists fewer suitable anaerobic digestion sites (bottom left), compared to the biogas map (bottom right) which includes sites with much lower capacities.

Appendix Nine – Depth of selected licensed but un-used sites

We have conducted a superficial investigation into the potential suitability of sites which are licensed for production, but which are currently un-used, as CCS nursery sites based only on site depth.

By filtering the site details data

(http://aquaculture.scotland.gov.uk/data/site_details.aspx?ctl00_ctl00_ContentPlaceholder1_ContentPlaceholder2_ctl00_gvResultsChangePage=63_15), for (1) sites which list Atlantic Salmon under species, (2) sites which have not been producing in the last 3 years, we get a list of 116 'empty' sites which could have potential as S-CCS sites.

The national grid reference given by the site details was converted to longitude/latitude using <https://gridreferencefinder.com>. This site was also used to produce the maps.

The depth of each site was determined using the longitude/latitude data and the SonarChart option on the Navionics Boating UK&Holland Version 9.1.1 app. Of those sites,

- 69 are <20m deep (red on the maps)
- 9 are between 20 and 25m (orange on the maps)
- 22 are between 25 and 75m (green on the maps)
- 11 are >75m deep (yellow on the maps)

and 5 of the listed GPS coordinates came up as being on-land (not shown on the map).

The maps are shown below:







Appendix Ten - SEPA licences and associated costs relevant to CCS use

Regulatory requirements and costs for the MC-incinerator systems, with and without energy capture, based on consultation with SEPA.

	Licenses and Permits	One-time application fees	Annual Charges (Activity Component)	Monitoring, Testing and Disposal Requirements
CCS Activities	CAR Licence – discharge from a marine cage fish farm (<50 tonnes biomass)	£3,152	£2,388 ¹	Video benthic survey once every 2 years (£500)
OR:	CAR Licence Discharge from a marine cage fish farm (>50 tonnes biomass)	£4,202	£3,592 ¹	Once yearly full benthic survey (£3,000)
Land-based Activities	Waste-Biomass or Animal Incinerator Licence	£2,101	£1,104	NA

¹If SEPA monitoring is required, this would increase the annual cost to £4,584.

Regulatory requirements and costs for the solids handling systems which store dried solids before transporting them off-site for disposal (MCLF, MCAD, MCC & MCLA), based on consultation with SEPA

	Licenses and Permits	One-time application fees	Annual Charges (Activity Component)	Monitoring, Testing and Disposal Requirements
CCS Activities	CAR Licence – discharge from a marine cage fish farm (<50 tonnes biomass)	£3,152	£2,388 ¹	Video benthic survey once every 2 years (£500)
OR:	CAR Licence Discharge from a marine cage fish farm (>50 tonnes biomass)	£4,202	£3,592 ¹	Once yearly full benthic survey (£3,000)
Land-based Activities	On-land solids storage ²	£0	£515	SEPA will need to determine the activity is a micro-scale activity and is of low environmental hazard ² .
AD-specific	Waste management licence for on-site AD	£2,101	£1,579	NA
	Solids composition testing for off-site AD	NA	NA	£82 for composition testing (annual)
	Disposal site requirements for off-site AD	NA	NA	AD site must have a PPC licence to accept fish waste.

	Licenses and Permits	One-time application fees	Annual Charges (Activity Component)	Monitoring, Testing and Disposal Requirements
Compost-specific	Solids composition testing for off-site composting	NA	NA	£82 for composition testing (annual)
	Disposal site requirements for off-site AD	NA	NA	Compost site must have a PPC licence to accept fish waste.
Land-Application Specific	Land application registration and approval by SEPA ³	£630	£488	Review of supporting information (£0) ³
	Solids composition for land application.	NA	NA	£82 for composition testing (annual).
	Before and after testing of agricultural/ecological soil.	NA	NA	£164 for composition testing (annual).
	Disposal site requirements for land application	NA	NA	Land application cannot take place within 10m of any watercourse, or within 50m of any well, spring or borehole used to supply water intended for human consumption. (SR2010)

¹ If SEPA monitoring is required, this would increase the annual cost to £4,584.

² If the activity is deemed not to be a micro-scale activity, or of high environmental hazard, there would be a £2,101 application fee and a £1,579 annual fee.

³ For land application approval, there must be a demonstrated ecological or agricultural benefit.

Appendix Eleven - Capital Cost (Price) Estimates for System Components

Table A11.1 Components for waste capture and treatment

Item	Baseline price (£) used in cost model	Sources	Depreciation period (years) used in cost model
0.5% Submersible Sump-pump	3,000	(Sterner 2018a)	5
2% Pump (peristaltic)	1,500	(Sterner 2018a)	5
10% Pump	1,500	(Sterner 2018a)	5
Grinder	5,000	(Sterner 2018a)	5
8in sump piping (/m)	27	(Plastic Pipe Shop 2018; Sterner 2018a)	5
6in to-shore piping (/m)	15	(Sterner 2018a)	5
Decanter Centrifuge	51,900	(Watropur 2017)	5
Rotary Drum	8,000	(Sterner 2018a)	5
On-CCS IBC Storage Containers	200	(Sterner 2018; Tanks Direct 2018)	5
Batch Dryer	65,200	(Watropur 2017)	10
Incinerator Cost with Energy capture	40,400	(Addfield 2018c) Author's assumption (3x price without energy capture)	10
Incinerator Cost without Energy capture	13,445	(Addfield 2018c)	10
Control and Monitoring System	40,000	(Sterner 2018a)	5
Waste System Installation Cost (%)	36%	(Sterner 2018; Zugarramurdi et al. 1995)	5 or 10
Contingency Factor	1.15	(Boulet et al. 2010; Zugarramurdi et al. 1995)	5 or 10

Notes:

All waste collection and treatment costs were derived for a single 6,000 m³ CCS – ie, no economies of scale are considered.

Table A11.2 Component prices for 6,000 m³ Aquafarm System (GRP)

Item	Total price (£)	unit price (£)	Note	unit	no	Source of price data	Depreciation (yrs)
GRP containment system minus cost of associated plant ⁷	1,196,740	217.79	Specified as 2,000 – 2,400 NOK/m ³ (£181.50 - £217.79)	m ³	6,000	http://aquafarm.no/economy/	25
Plant:							
Axial pumps x4 X 20 kVA	60,000	15,000	4 x 20 kVA		4	Estimate	5
Intake screens and mountings x 4	2,000	500			4	Estimate	5
Controllable outlet valves x 8	8,000	1,000			8	Estimate	5
Emergency oxygen system	30,000	30,000			1	Estimate	5
Additional monitoring and control	10,000	10,000			1	Estimate	5
Additional platform for waste treatment:							
Raft for plant	40,000	40,000	for screen filter, sludge pump, centrifuge		1	Gael Force Triton 450 raft 12m x 6m steel top, 12 - 14t net buoyancy	5
Modification of raft - eg weatherproofing	10,000	10,000			1	Estimate	5
Total:	1,356,740						
Share of system upgrade costs							
Moorings	42,000	140,000	nb £100 - 180k		3	Commercial quote from Gael Force 2018	5
Additional generator capacity and electrical distribution	30,000	300,000			1		5

⁷ NB, cost of plant subtracted in order to adjust for various depreciation rates)

Table A11.3
Component prices for 6,000 m³ Botngaard system (flexible fabric)

Item	Total price (£)	unit price (£)	Note	unit	no	Source of price data	Depreciation (yrs)	
Flexible containment system complete	900,000	150		/m ³	6,000	Quote from Botngaard system £1.2m for 8,000m ³	5	
Raft for plant	40,000	40,000	for screen filter, sludge pump, centrifuge		1	Gael Force Triton 450 raft 12m x 6m steel top, 12 - 14t net buoyancy	5	
Modification of raft - eg weatherproofing	10,000	10,000			1	Estimate	5	
Total:	950,000							
Share of system upgrade costs								
Moorings	28,000	140,000		0	2	Commercial quote from Gael Force 2018 (nb range £100 - 180k)	5	
Additional generator capacity and electrical distribution	30,000	300,000		0	0	1	Estimate	5

Table A11.4
Component prices for 6,000 m³ flexible fabric system (design exercise by project partners)

Item	Total price (£)	unit price (£)	Note	unit	no	Source of price data	Depreciation (yrs)
3 ring 400mm 80m floatation collar	35,000	35,000	per 3 ring collar		1	Gael Force 2018 quote for Triton superstructure	5
Additional buoyancy	23,310	35,000	pro rata on collar price		0.666	Gael Force quote 2018	5
Modification of superstructure for fittings for fabric	10,000	10,000			1	Estimate	5
Sinker tube	12,000	150	For 50kg/m ring.	per m	80	Gael Force 2018	5
Sinker tube		300	for 100kg/m	per m	80	Gael Force 2019	5
Raft for plant	40,000	40,000	for screen filter, sludge pump, centrifuge		1	Gael Force Triton 450 raft 12m x 6m steel top, 12 - 14t net buoyancy	5
Modification of raft - eg weatherproofing	10,000	10,000			1	Estimate	5
Pump stations x 4	20,000	20,000			1	Estimate	5
Axial pumps	60,000	15,000	4 x 20 kVA		4	Estimate	5
400mm (352mm ID) Intake pipes		57		per m			5
500mm (441 id) intake pipes	12,401	89	4 x 35m for 1 unit	per m	140	Gael Force 2018 SDR 17 pipe 10 bar	5
630mm (555mm id) intake pipes		141		per m			5
Intake screens and mountings x 4	2,000	500			4	Estimate	5
Controllable outlet valves x 8	8,000	1,000			8	Estimate	5
Emergency oxygen system	30,000	30,000	system for a single unit		1	Estimate	5

Item	Total price (£)	unit price (£)	Note	unit	no	Source of price data	Depreciation (yrs)
Additional monitoring and control	10,000	10,000	system for a single unit		1	Estimate	5
Fabric bag	145,000	145,000			1	Knox (project partner design exercise) 2018	5
Contingency	62,657				15.0%		5
Total:	480,368						
Share of system upgrade costs							
Moorings	42,000	140,000			0.3		5
Additional generator capacity and electrical distribution	30,000	300,000			0.1		5

Table A11.5
Component prices for 6,000 m³ heavyweight concrete system (design exercise by project partners)

Item	Total price (£)	unit price (£)	Note	unit	no	Source of price data	Depreciation (yrs)
Heavyweight Concrete	5,890,000	5,890,000			1	Design exercise by project partners	25
Intake screens and mountings	2,000	500			4	Estimate	5
Controllable outlet valves x 8	8,000	1,000			8	Estimate	5
Emergency oxygen system	30,000	30,000			1	Estimate	5
Additional monitoring and control	10,000	10,000			1	Estimate	5
Axial pumps x4 X 20 kVA	60,000	15,000	4 x 20 kVA		4	Estimate	5
Raft for plant	40,000	40,000	for screen filter, sludge pump, centrifuge		1	Gael Force Triton 450 raft 12m x 6m steel top, 12 - 14t net buoyancy	5
Modification of raft - eg weatherproofing	10,000	10,000			1	Estimate	5
Total:	6,050,000						
Share of system upgrade costs							
Moorings	168,000	140000		nb £100 -	12	Commercial quote from Gael Force 2018	5
Additional generator capacity and electrical distribution	30,000	300,000			1		5

Table A11.6
Component prices for 6,000 m³ lightweight concrete system (design exercise by project partners)

Item	Total price (£)	unit price (£)	Note	unit	no	Source of price data	Depreciation (yrs)
Lightweight Concrete	850,000	850,000	Shell only; plant specs used as for other systems		1	Estimate from concept design study from CMS	20
Raft for plant	40,000	40,000	for screen filter, sludge pump, centrifuge		1	Gael Force Triton 450 raft 12m x 6m steel top, 12 - 14t net buoyancy	5
Modification of raft - eg weatherproofing	10,000	10,000			1	Estimate	5
Pump stations x 4	20,000	20,000			1	Estimate	5
Axial pumps	60,000	15,000	4 x 20 kVA		4	Estimate	5
500mm (441 id) intake pipes	12,401	89	4 x 35m for 1 unit	per m	140	Gael Force 2018 SDR 17 pipe 10 bar	5
Intake screens and mountings x 4	2,000	500			4	Estimate	5
Controllable outlet valves x 8	8,000	1,000			8	Estimate	5
Emergency oxygen system	30,000	30,000			1	Estimate	5
Additional monitoring and control	10,000	10,000			1	Estimate	5
Compressor	20,000	20,000			1	Estimate	5
Contingency	159,360				0.15		5
Total:	1,221,761						

Item	Total price (£)	unit price (£)	Note	unit	no	Source of price data	Depreciation (yrs)
Share of system upgrade costs							
				nb £100			
Moorings	112,000	140,000		-	8	Commercial quote from Gael Force 2018	5
Additional generator capacity and electrical distribution	30,000	300,000			1		5

Institute of **Aquaculture**



www.aqua.stir.ac.uk



Charity Registration: SC035745
 Company Registration: SC267177

SARF - Member Organisations

Industry



Government and Regulators



Non-Governmental Organisations

