

## The LED and fiber based calibration system for the photomultiplier array of SNO+

This content has been downloaded from IOPscience. Please scroll down to see the full text.

2015 J. Phys.: Conf. Ser. 587 012031

(<http://iopscience.iop.org/1742-6596/587/1/012031>)

View [the table of contents for this issue](#), or go to the [journal homepage](#) for more

### Download details:

IP Address: 188.184.3.52

This content was downloaded on 24/06/2015 at 12:16

Please note that [terms and conditions apply](#).

# The LED and fiber based calibration system for the photomultiplier array of SNO+

L. Seabra<sup>a</sup>, R. Alves<sup>b</sup>, S. Andringa<sup>a</sup>, S. Bradbury<sup>c</sup>, J. Carvalho<sup>b</sup>, K. Clark<sup>d</sup>, I. Coulter<sup>e</sup>, F. Descamps<sup>f</sup>, L. Falk<sup>d</sup>, L. Gurriana<sup>a</sup>, C. Kraus<sup>g</sup>, G. Lefevre<sup>d</sup>, A. Maio<sup>ahj</sup>, J. Maneira<sup>ah</sup>, M. Mottram<sup>d</sup>, S. Peeters<sup>d</sup>, J. Rose<sup>i</sup>, J. Sinclair<sup>d</sup>, P. Skensved<sup>k</sup>, J. Waterfield<sup>d</sup>, R. White<sup>d</sup>, J. Wilson<sup>l</sup>, for the SNO+ collaboration

<sup>a</sup>Laboratório de Instrumentação e Física Experimental de Partículas (LIP), Av. Elias Garcia, 14, 1,1000-149 Lisboa, Portugal,

<sup>b</sup>Laboratório de Instrumentação e Física Experimental de Partículas and Departamento de Física, Universidade de Coimbra, 3004-516 Coimbra, Portugal,

<sup>c</sup>School of Physics and Astronomy, University of Leeds, Leeds LS2 9JT, United Kingdom,

<sup>d</sup>Dept. of Physics and Astronomy, University of Sussex, Falmer Campus, Brighton BN1 9QH, United Kingdom,

<sup>e</sup>Dept. of Physics, Oxford University, Denys Wilkinson Building, Keble Road, Oxford, OX1 3RH, United Kingdom,

<sup>f</sup>Nuclear Science Division, Lawrence Berkeley National Laboratory, Berkeley, California 94720, USA,

<sup>g</sup>Dept. of Physics and Astronomy, Laurentian University, Sudbury, Ontario P3E 2C6, Canada,

<sup>h</sup>Departamento de Física, Faculdade de Ciências da Universidade de Lisboa, Campo Grande, Edifício C8, 1749-016 Lisboa, Portugal,

<sup>i</sup>Dept. of Physics, University of Liverpool, Liverpool L69 7ZE, United Kingdom,

<sup>j</sup>Centro de Física Nuclear da Universidade de Lisboa, Av. Prof. Gama Pinto, 2, 1649-003 Lisboa, Portugal,

<sup>k</sup>Queen's University, Physics Dept., Kingston, Ontario K7L 3N6, Canada,

<sup>l</sup>School of Physics and Astronomy, Queen Mary, University of London, 327 Mile End Road, London, E1 4NS, United Kingdom.

E-mail: lseabra@lip.pt

## Abstract.

A new external LED/fiber light injection calibration system was designed for the calibration and monitoring of the photomultiplier array of the SNO+ experiment at SNOLAB. The goal of the calibration system is to allow an accurate and regular measurement of the photomultiplier array's performance, while minimizing the risk of radioactivity ingress. The choice in SNO+ was to use a set of optical fiber cables to convey into the detector the light pulses produced by external LEDs. The quality control was carried out using a modified test bench that was used in QC of optical fibers for TileCal/ATLAS. The optical fibers were characterized for transmission, timing and angular dispersions. This article describes the setups used for the characterization and quality control of the system based on LEDs and optical fibers and their results.

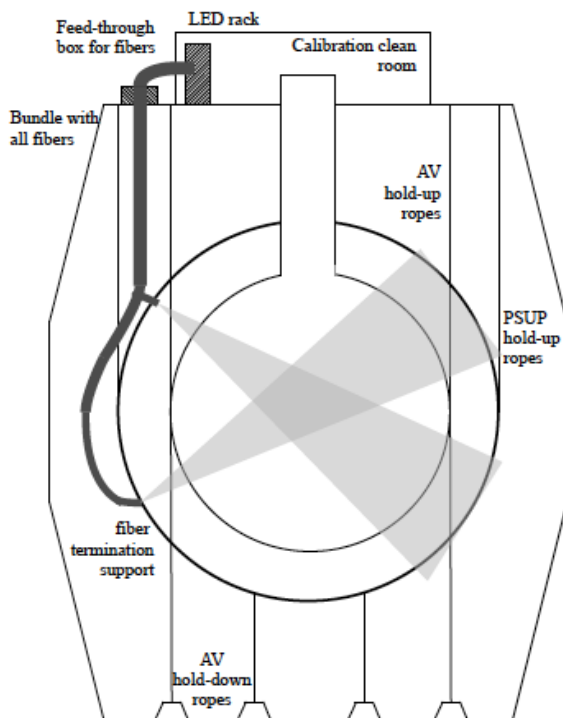


## 1. Introduction

The SNO+ (Sudbury Neutrino Observatory) detector has many Physics goals including the search for neutrinoless double beta decay, the detection of pep and CNO solar neutrinos, the detection of geo-neutrinos and the study of reactor neutrino oscillations [1](see talk of A. Maio in these proceedings [2]).

The detector, installed in the Creighton mine near Sudbury, Canada at a depth of 2000 meters, was previously used with heavy water as active element (for the detection of solar neutrinos) and will now use liquid scintillator (LAB, PPO and  $^{130}\text{Te}$ ). The detector is composed by a 12 m diameter spherical acrylic vessel with 5 cm thickness that will be filled with 780 tons of active material. Around the vessel there is a geodesic structure with  $\sim 9000$  PMTs. The cavern where the detector is installed will be filled with purified water and, because the density of the liquid scintillator is lower than the heavy water, the acrylic vessel will have a rope basket attached to the cavern floor. The detector depth serves as a barrier to cosmic rays but the detector is still not free from unwanted radiation. Radioactive decays of residual impurities present in the scintillator and detector materials constitute an important background. The radiopurity requirements are very high for the liquid scintillator ( $1 \times 10^{-17} \text{g/g}$ ) and progressively relaxed for more external materials like acrylic, water and PMTs. The events originated by gammas from external materials concentrate in the most external layers of the scintillator volume and can be removed with a position selection of the events. The position measurement is based on time information given by PMTs and therefore the precision depends on the quality of the synchronization between PMTs.

In the calibration system (Figure 1), optical fibers, placed in the PMTs support structure, emit cones of light that will pass through the whole detector and will illuminate one group of PMTs on the opposite side of the detector. The principal requirements on this light cone are the time and angular dispersion. The time dispersion of light at the fiber exit should not be much higher than the resolution in time of the SNO+ components. The irreducible components are PMTs jitter (1.6 ns) and scintillator decay time (5 ns) so the desired time dispersion is of the order of a few ns [3].



**Figure 1.** Schematics of the detector calibration system where the light produced by LEDs travel through optical fibers into several points in the PMT structure. Each optical fiber emits a cone of light that will pass through the whole detector and will illuminate one group of PMTs on the opposite side of the detector.

The angular dispersion of the optical fibers is an important parameter on the global system project because the total number of fibers is dependent of the cone aperture. For redundancy reasons, and to account for possible fiber failure, all the  $\sim 9000$  PMTs must be illuminated, at least, by two light cones. Furthermore, this redundancy allows for cross-synchronization between the PMT regions illuminated by different fibers. For installation reasons the number of fibers should not be higher than strictly necessary. 96 double optical fibers plus spares were installed in the PMT structure, each of them connected to one LED placed outside the detector cavern.

## 2. System Components

### 2.1. Optical fibers

The optical fibers are 45 meters long with single cladding with a numerical aperture of 0.51 and a refractive index of 1.49. The core with 1 mm of diameter is composed by polymethyl methacrylate (PMMA) and the cladding by a fluorinated polymer. Each fiber cable has two optical fibers (one as spare) coated with black polymer. The wet-end connector is a duplex latching and the dry-end connector is a ST. Each optical fiber is connected to a custom made support plate that is attached to the side of a PMT in one of the geodesic nodes in the PMT structure. This choice ensures a uniform coverage of all PMTs.

### 2.2. LED

The selected LED has the highest possible peak wavelength in order to achieve the optimal direct transmission. The limiting factor is the quantum efficiency of the SNO photomultiplier tubes and the absorption probability in the scintillator mixture. The optimal peak wavelength was found to be  $505.6 \pm 2.6$  nm. The chosen LED has a low differential resistance in the near linear region which allows for a pulse width of the same order as the Transit Time Spread of the SNO PMTs.

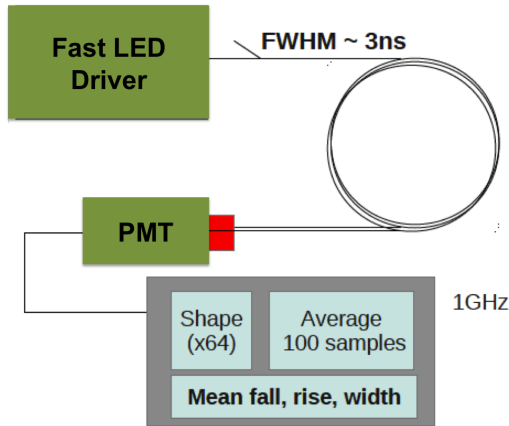
### 2.3. Driver

The driver circuit is capable of operating with a dynamic range of frequencies, between 10 Hz and 10 kHz, in order to perform monitoring at low frequencies and calibrations at high frequencies. It can generate pulses with a full width half maximum (FWHM) of the order of 4 ns.

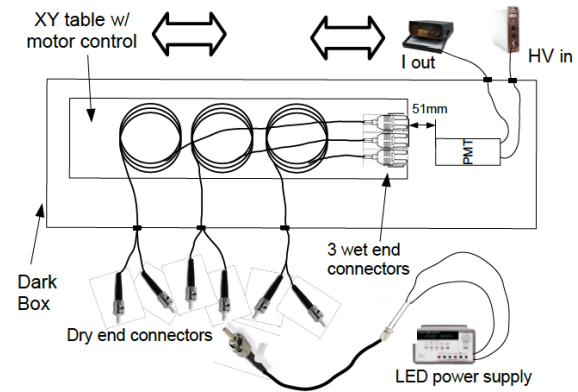
## 3. Characterization of optical fibers and Quality Control

All the 110 optical fibers were subject to characterization and quality control measurements for transmission, timing and angular dispersions. For the time dispersion the measurements were made using a LED driver that gives a signal in the order of 3 ns of FWHM. The signal travels through the optical fiber into a PMT where it is read by an oscilloscope (Figure 2). From the measurements a low time dispersion was obtained with a FWHM of the order of 4 ns (Figure 4).

For angular dispersion a two-dimensional scan of one optical fiber was done using a PMT in single photo-electron mode with a very low LED intensity and a neutral density filter on the duplex connector. Quality control was carried out using a test bench that was used in QC of optical fibers for TileCal/ATLAS [4][5]. This base automated test-bench was adapted to check the light output at different angles in a transverse scan, in order to cross-check the variation of the angular opening between fibers. The peak value and the integration of the angular scan gave also the variability in terms of light transmission. Figure 3 shows the interior of the dark-box, adapted for this test. Three duplex fibers, being illuminated independently from outside the dark-box, could be checked in each single run. The edges of some of the angular distributions were cut for some of the fibers and showed some distortions, but the central part was consistent for all the six tested positions, with the variations in between the 220 fibers

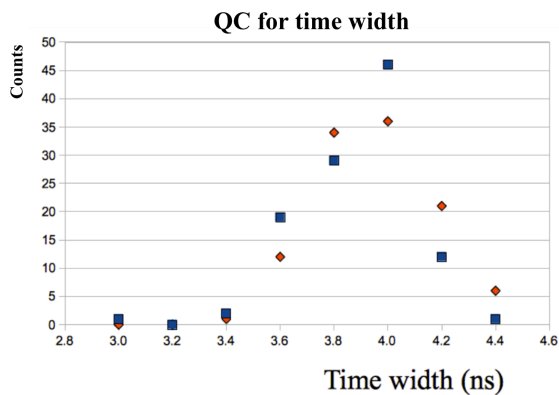


**Figure 2.** Set-up for the time dispersion measurements.

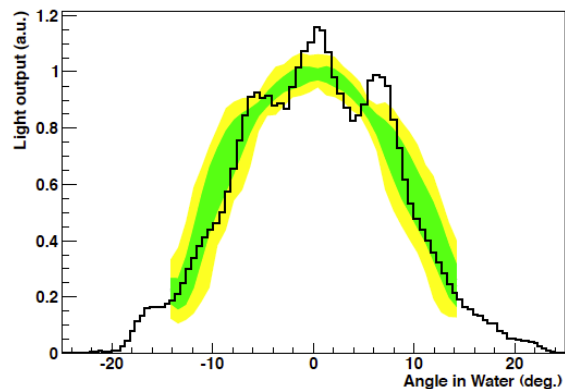


**Figure 3.** The interior of the dark-box, showing the mounting of three 45 m duplex fiber cables in front of the PMT.

shown in Figure 5, where they are compared with the higher resolution test of a single fibre in the two-dimensional scan given an aperture angle of 14.5 degrees. Taking in consideration the results in QC for transmission, timing and angular dispersions some optical fibers were selected as spares. Nevertheless these results reveal a good uniformity between optical fibers.



**Figure 4.** Time width dispersion of all 110 duplex fibers with an injected signal of 3 ns. The blue dots and the red are for different fibers from the duplex latching connector.

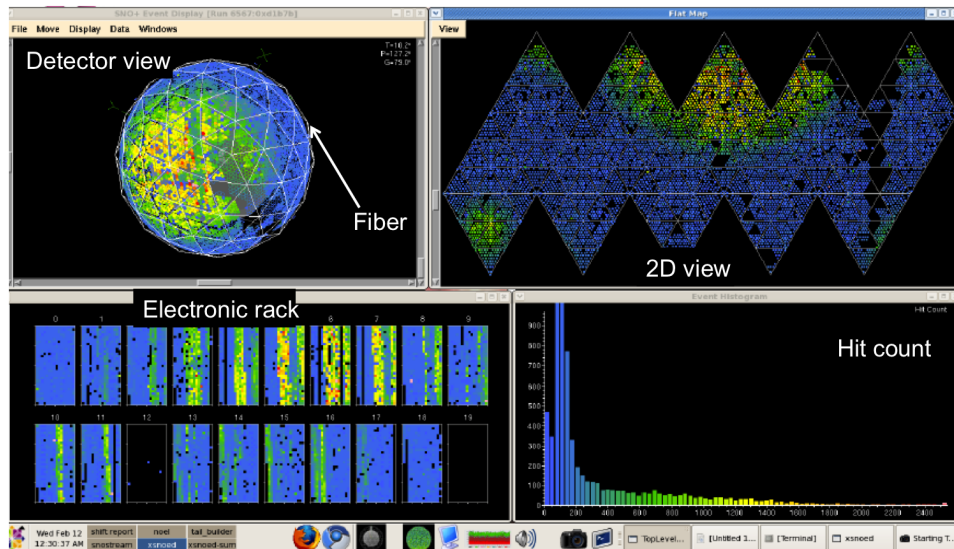


**Figure 5.** The black histogram is the profile of the detailed 2D measurement. The bands summarize the stability measurements of the 110 duplex cables: the yellow band shows the overall spread, the green band represents the measurement uncertainty.

#### 4. Commissioning

The installation of the new calibration system is in progress: 36 of 96 light injection fibers are already fully installed and have been tested in commissioning runs of SNO+ electronics, with the full dark detector and the scintillator and water regions filled with air. On the 2D view of Figure 6 is possible to see a spot far from the main charge collection that corresponds to the light reflections in the acrylic vessel near the fiber injection. In order to validate the measured angular distribution, the commissioning results were compared to simulations that used the

existing measurements as input. A good match was obtained for the distribution of intensity versus angle, confirming that the system will have enough coverage for all PMTs.



**Figure 6.** Display of a commissioning dry run with a single fiber injection where 11.2 Million triggers were obtained. Each dot corresponds to a PMT where the color indicates the collected charge.

## 5. Summary

The calibration of  $\sim 9000$  PMTs can be done with the external LED/fibers system using only 96 optical fibers, with aperture angles 14.5 degrees in water, which guarantees a full detector coverage. The calibration signal created by the Driver+LED+fiber has a time width of  $\sim 4$  ns, sufficient for the synchronization and time versus charge calibration. The new calibration system is under installation and the first commissioning shows promising results.

## 6. Acknowledgments

Research supported by EU FEDER funds through the COMPETE program 674 (Operational Program for Competitiveness Factors) and by national funds from Portugal through 675 FCT (Fundação para a Ciência e a Tecnologia) within the project PTDC/FIS/115281/2009.

## 7. References

- [1] Chen, M.C. "The SNO+ Experiment" 2008 *Proceedings of the 34th International Conference on High Energy Physics*.
- [2] A. Maio "Search for Neutrino Double Beta Decay with SNO+" 2014 *Proceedings of the CALOR 2014*.
- [3] B. Caccianiga, D. Franco, D. Giugni, P. Lombardi, S. Malvezzi, J. Maneira, G. Manusardi, L. Miramonti, G. Ranucci, O. Smirnov, "A multiplexed optical-fiber system for the PMT calibration of the Borexino experiment" 2003 *Nuclear Instruments and Methods in Physics Research A* **496** 353-36
- [4] J.Santos, A. Maio, J.G.Saraiva, J. Silva and L. Gurriana 2007 *Characterization of plastic optical fibers with pulsed LEDs*, in *Nuclear Instruments and Methods in Physics Research A* **580** 306-309
- [5] M. David et al 1998 *Tilecal-pub-2008-003*