

## **Fuzzy Logic Traction Control —Visual block diagram approach—**

**Kazuyuki Kobayashi\*, Kajiro Watanabe\* and Ka C. Cheok\*\***

### **Abstract**

In this paper, we describe the effective procedures in designing and implementing a fuzzy logic traction control system to the actual test truck by using a PC-based computer was used for on-line data acquisition and decision control and actual implementation of the traction control scheme algorithm. To describe the traction the tractin control scheme, visual block approach is employed by using SIMULINK® block. In order to accomplish the real-time control, we utilize real-time workshop which is provided by Mathworks that can automatically generated C-code from SIMULINK block. By using this, it makes possible the quick development and debugging and simulation through the actual experments. This approach other advanced control algorithms.

### **1. Introduction**

The prevalence of microprocessor-based controllers in moden automotive systems has greatly increased need for tools which can used to validate and test these control systems over their full range of operation. However it is very difficult and time consuming to acquire data from vehicle and to turn the parameters of the vehicle. One methodology which is particularly well suited to this task is that of DSP based approach is popular, however in order to tune the parameter and/or algorithms.

PC-based computer approach can solve the most of the problems. Especially, available fast processor which usually including math coprocessor such as Pentium-based and /or PowerPC-based computer can achieve the enough speed for real-time control like as DSPbased Computer even if the program is written by the high level language. The advantage of PC-based computer approach enables quick development and debugging and modification and simulation on the same machine. Which meansit can greatly reduce the developing and debugging and modiffication time in comparison with DSP approach.

This paper describes our efforts at designing and implementing a practical fuzzylogic traction control system for the quick development by using the SIMLINK with RealTime woekshop. To

---

\*System and Control Engineering\*\*, Oakland Univ.  
Department of Electrical and Systems Engineering.

apply complicated algorithm such as fuzzy logic, Simulink is employed for visual based programming approach make possible the quick development and intuitive implementation and verification through the actual experiments and simulation. The controller is designed based on the basic control concept which come up with the expert knowledge of the traction control with understanding of the vehicle mechanism. To implement the expert knowledge, fuzzy logic is applied and fine-tuned based on expert driver's feeling.

## 2. Simulink Real Time Workshop

SIMULINK is a tool for modeling, analyzing, and simulating a wide variety of physical and mathematical systems as well as engineering problems, including those with nonlinear elements and those which make use of continuous and discrete time by using visualized block diagram. The SIMULINK Real-Time Workshop can generate C code directly from SIMULINK visual block diagram. Figure 1 shows the overview of the structure of Real Time Development system.

This allows the execution of continuous, discrete-time, and hybrid system models on a wide range of computer platforms, including real-time hardware. Real-Time Workshop can be used as a rapid prototyping tool which enables to implement designs quickly without lengthy hand coding and debugging. Control, signal processing, and dynamic system algorithms can be implemented by developing graphical SIMULINK block diagrams and automatically generating C code with embedded Real-Time Control. Once a system has been designed with SIMULINK, code for real-time can be generated, compiled, linked, and executed on target machine processor. It can

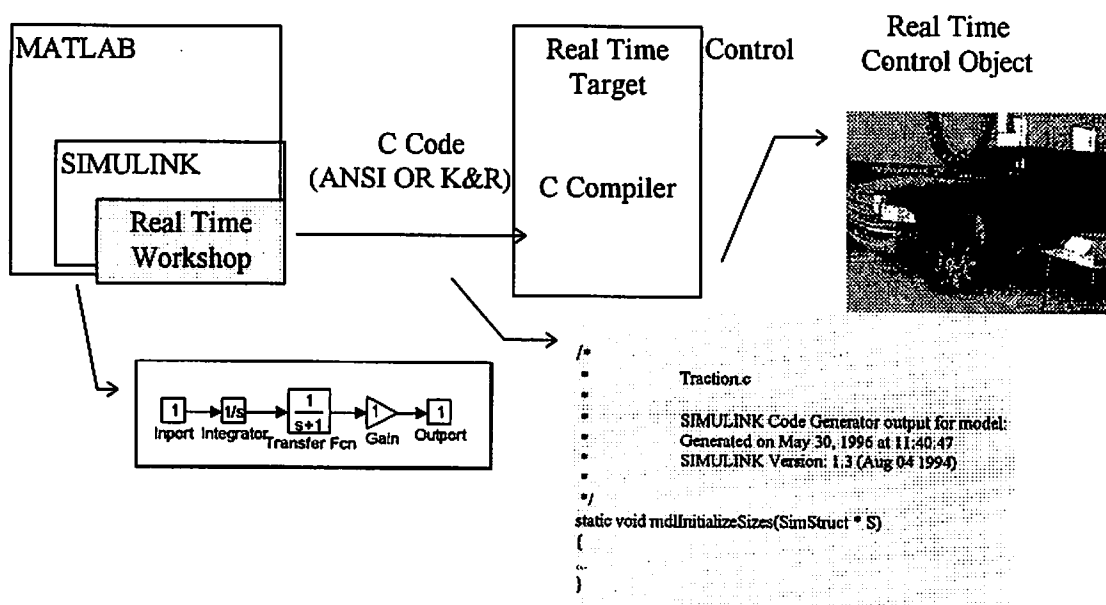

Figure 1. Real Time Control Scheme

create and execute code for an entire system or specified subsystems for hardware-in-the-loop simulations. Time histories can be saved in MATLAB (binary or ASCII files), they can be easily loaded into MATLAB for additional analysis or graphic display. Real-Time Workshop provides a comprehensive set of features and capabilities that provide the flexibility to address a broad range of applications. Automatic code generation handles continuous-time, discrete-time, and hybrid systems. Optimized code guarantees fast execution. The SIMULINK Real-Time Workshop automatically translates a SIMULINK model into commented ANSI or K&R style C code for real-time applications.

Detail of Real-Time code generation is described in [1].

### 3. Traction Control Background

Traction Control System (TCS) or Acceleration Slip Reduction (ASR) is one of complex computer control techniques which is designed to prevent the drive wheels from spinning in response to application of excessive throttling. The goal of Traction Control System is to generate in real time the largest possible traction force while keeping the vehicle maneuverable and avoiding excessive wheel slippage. The absence of sensors capable of detecting on-line measurement variables, such as tire slip ratio and road condition, forces the TCS system designer to seek means to infer the road condition from the few available sensory data. The most important process parameters affecting the quality of control are the coefficient of friction between tire and road, the tire slip ratio, and the vertical force on between tire and road surface. The plant to be controlled comprises significant transportation delays which limit the frequency responses of the controller.

Commercial TCS systems have been on the market around 10 years [2, 3, 4, 5]. A discussion of customary TCS systems is found in [6]. Because of availability of high performance microprocessor, a digital based controller is necessary to implement control scheme. Although an improvement over controller designs, the digital controller must sample a sufficient set of new data points after each change of plant parameters before it can compute the poles and zeros of the new controller. This requirement introduces a significant additional delay of several sampling periods each time a new control law is computed. Fuzzy controllers, on the other hand, have an inherently parallel structure, which allows the controller to respond immediately once a new situation has been identified.

Detailed discussions of fuzzy control theory, its advantage, and theoretical foundations is found, among others, in [7]. Fuzzy controllers differ from model-based controllers in that they encode heuristic knowledge. When properly designed, the performance of fuzzy controllers compare

favorably with that of advanced model-based digital controllers. Despite the absence of analytical modeling information, systems governed by fuzzy controllers are often highly robust. Learning fuzzy controllers are described by [8].

Fuzzy logic good application of traction control scheme. However in order to implement information and test the fuzzy logic controller for real vehicle in actual environment, it is required some sophisticated data acquiring and algorithm developing tools. Therefore we utilize SIMULINK and Real Time workshop as the tool for development and analysis.

#### 4. Fuzzy Logic scheme

The Fuzzy logic takes into account the expert knowledge and understanding of the sensor and actuator capabilities and limitations. The fuzzy logic scheme employed is a two-tier logic shown in Table 1. Table 1 (1) shows the fuzzy logic rules for activation of individual brakes (Front Right, Front Rear Right, Rear Left). Table 1 (b) uses the consequence of Table 1 (a) to actuate the throttle relaxer and gear upshift. The ground speed of the vehicle in four-wheel drive (4WD) is estimated the minimum value of the four wheel speed. This assumption is justified by the argument that the truck is equipped with front and rear differentials. The Fuzzy set membership for Slip is labeled as fuzzy values, S and L for small and large, respectively. Trspd and Throt are transmission speed and throttle position information supplied by the transmission control unit. They are similarly categorized by the fuzzy label S and L, for representing small and large memberships. We should emphasize that the S's and L's associated with Slip, Trspd and Throt are entirely different for each association. Trapezoidal functions were used to define these memberships. The parameters for the above fuzzy values S and L were determined by optimization through a series of experiments. Pressure in the brake hydraulic unit for each wheel is controlled by a motor/pump and a set of three solenoid valves. The vehicle configuration allows the brake pressure to be regulated at a 0 percent, 50 percent or 100 percent duty cycle. S, M and L are used to describe the fuzzy values values Brake. Braking logic is a three antecedent/one consequence fuzzy logic. The first fuzzy rule says that if the inputs Trspd, Throt and Slip are all L (in their respective definitions of L), then the brake application should be L (again large in the definition of braking action). The rest of the rules specified in the rows of Table 1 (a) are interpreted in the same way. The results of the brake logic are monitored and used in the second set of fuzzy logic to actuate the throttle relaxer and upshift the Table 1 (b), therefore, is a four input/antecedent (Brake) and two output/consequence (Throttle and Upshift). Each wheel brakes FR, FL, RR, RL are the commands issued by the first control logic, Throttle and Upshift are the control actions for relaxing the throttle and shifting the gears. The approach for determining the parameters for

Table 1. Two-Tire Fuzzy logic rules for TCS

(a) Fuzzy rules for individual brake actuation (FR, FL, RR, RL) (b) Fuzzy rules for throttle relaxer and gear upshift actuation

Throt	S	L	S	L
Slip	S	S	L	L
Trspd	S	S	M	L
	L	S	L	L

FR	S	S	M	S	M	L	L	M	L
FL	S	M	S	L	M	S	M	L	L
RR									
RL									
S	S		S			S		S	L
S	M								
M	S		S			S		L	L
S	L								
M	M								
L	S		S					L	L
L	M								
M	L		S					L	L
L	L		L					L	L

parameters for the memberships for the fuzzy values is similarly carried out using experimental optimization.

We note that each control action, such as Brake (FR, FL, RR, RL), Throttle and Upshift, is a software class function that does a sequence of steps to properly acutate the respective hardware. Similarly, each sensing information, such as Slip, Trspd and Throt, represents a software class function that information from the sensors and the transmission controller class module.

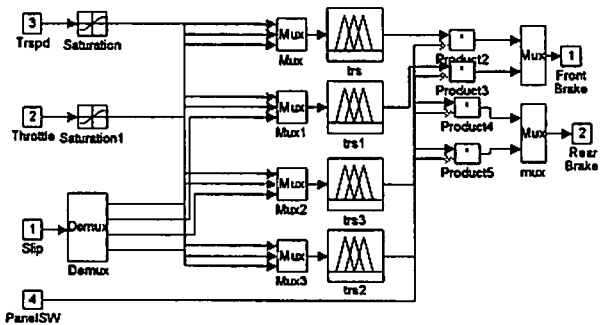
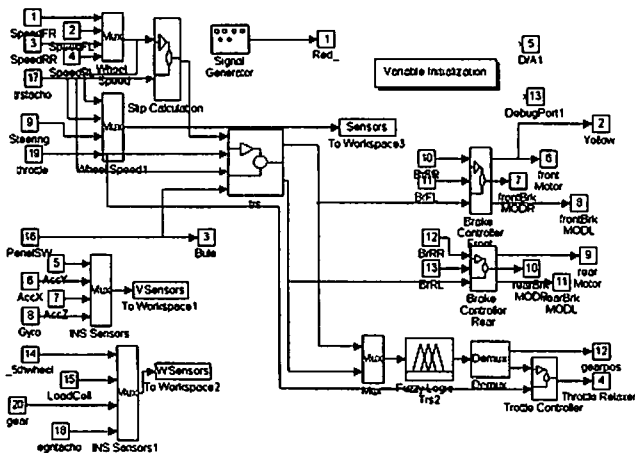
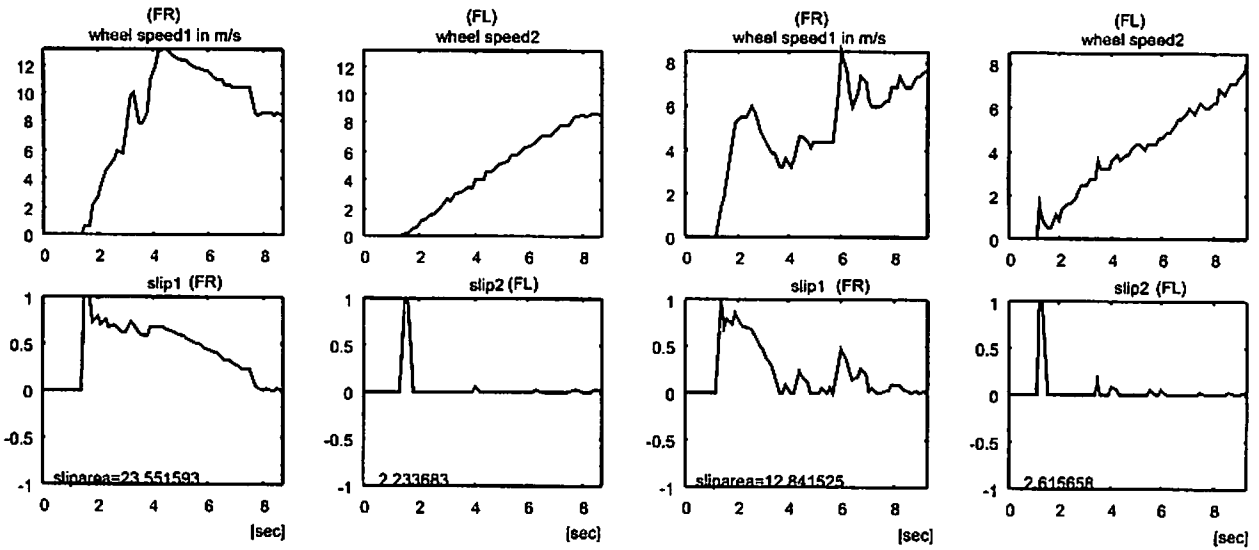

Figure 3(a). Actual diagram for FLTCS by SIMULINK Figure 3(b). Actual diagram for FLTCS in Fuzzy logic block



(a) without traction control      (b) with traction control

Figure 4. Experimental test results

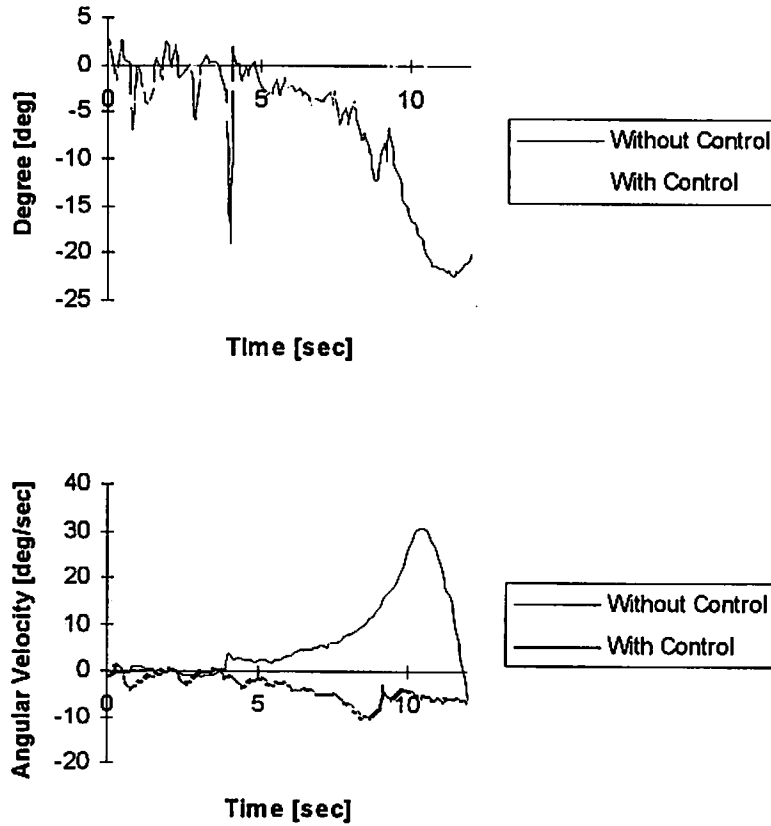

Figure 5. (a) Steering wheel angle in packed snow with full throttle  
(b) Gyro output in packed snow with full throttle

## 5. Actual implementation and Experiments

Figure 3 (a), (b) show the actual developed diagram by using SIMULINK in while we tuned parameters. Extensive experiments have been carried out the performance of the fuzzylogic based TCS. Successful satisfactory performance were achieved after several fine tuning of the TCS. Samples of the TCS performance are shown in Figs. 4 and 5. Fig. 4 compares the individual wheel speed of the truck accelerating over split adhesion surface under full throttle, without the TCS (Fig. 4a) and with TCS (Fig. 4b). The figures demonstrate regulation of the wheel slips by the FLTCS. Fig. 5 shows the yaw stability of the vehicle acceleration over packed snow surface with no driver's assistance on steering with and without the TCS. The comparison clearly shows that the vehicle without the TCS become unstable or spun out of control after about 7 secs, while the one with the TCS held its stability under similar acceleration condition.

## 6. Conclusion

In this paper, we describe the visual block based development approach for quick automotive control applications. In order to overcome the problem of complexity, we utilize the fuzzy logic controller in which parameters are easily tuned by using visual block based approach. As a result, rapid and error-less modification and development are achieved. This approach has potentially to use other advanced control technique such as neural network as well as robust control schemes.

## References

1. Mathworks, Inc, "www. mathworks. com/pub/tech-support/library/ttw/mi"
2. G P Farr, "A simple traction control", C371 IMechE, 1998
3. Tadao Tanaka and Kenji Isoda, "Traction Control System, "JSME International Journal Series III, Vol. 35, No. 1, 1992
4. E Petersen, J Rothen "ABS with integrated drive slip control (ASR) for air-braked commercial vehicles modular concept, function principles, performance, "C374, IMechE, 1988
5. B.G Schulze, E Lissel "Anti-slip-regulator system (ASR) with high performance and confort, "C367, Imech, 1988
6. Frances B. Hoogterp, Ka C. Cheok, Kazuyuki Kobayashi, Walter K. Fales, Sandro Scaccia, "Fuzzy Logic Approach to Traction Control Design", SAE96 (960957), 1996 Feb, Detroit, USA
7. H.R. Berenji, "Fuzzy Logic Comtrollers, "An introduction to Fuzzy Logic Applications in

Intelligent Systems, Kluwer Academic Publishers, pp. 69-96, 1992

8. J.R. Layne, M. Passion and Yurkovich, "Fuzzy Learning Control for Antiskid Braking Systems," IEEE Trans. Control Systems, Vol. 1 June pp. 122-129, 1993