

Green Chemistry

Cutting-edge research for a greener sustainable future

www.rsc.org/greenchem

Volume 13 | Number 4 | April 2011 | Pages 725–1040

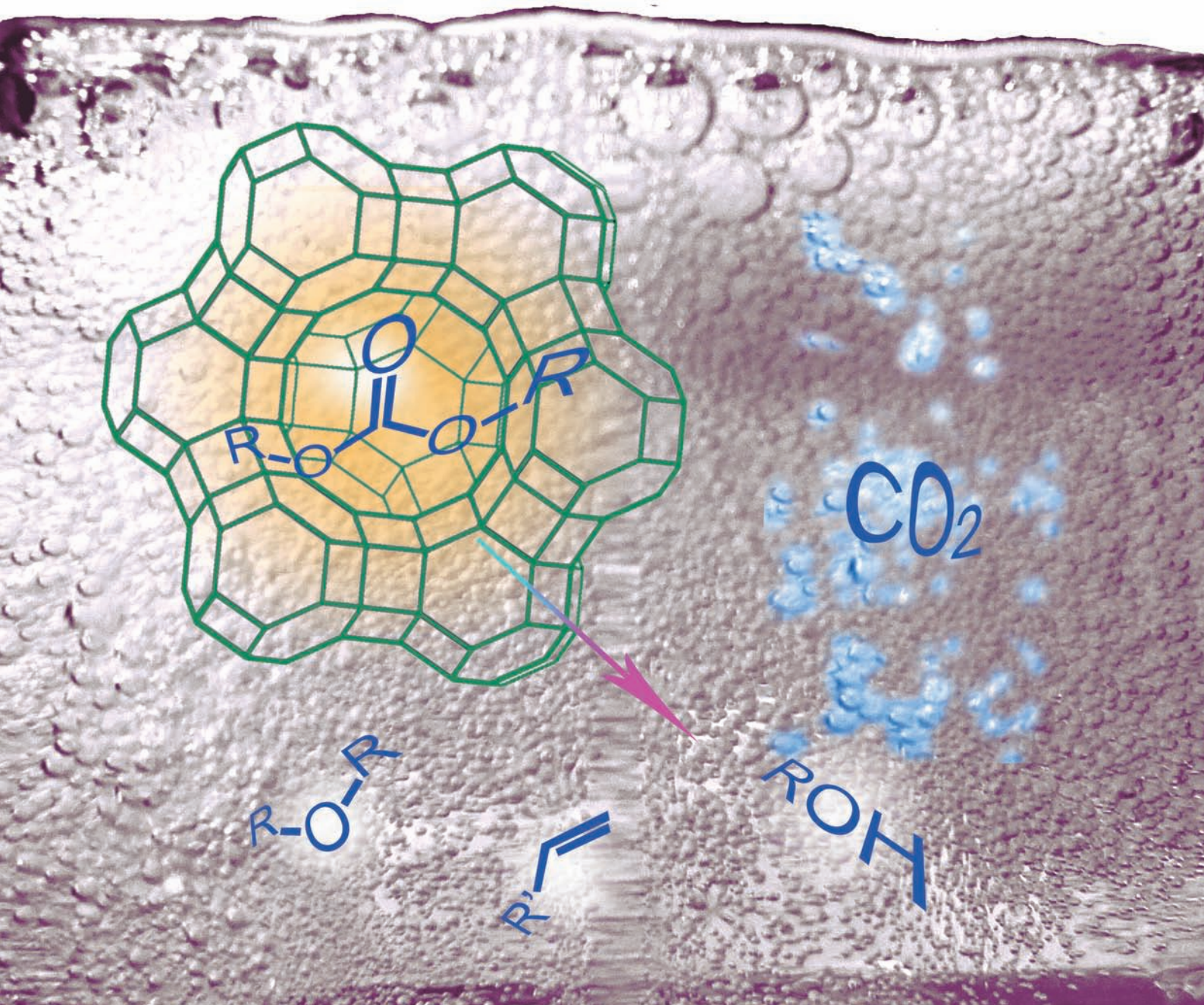

ISSN 1463-9262

RSC Publishing

COVER ARTICLE

Selva *et al.*
Decarboxylation of dialkyl
carbonates to dialkyl ethers over
alkali metal-exchanged faujasites



International Year of
CHEMISTRY
2011



1463-9262(2011)13:4;1-V

Cite this: *Green Chem.*, 2011, **13**, 863

www.rsc.org/greenchem

PAPER

Decarboxylation of dialkyl carbonates to dialkyl ethers over alkali metal-exchanged faujasites†

Maurizio Selva,* Massimo Fabris and Alvise Perosa

Received 10th September 2010, Accepted 8th December 2010

DOI: 10.1039/c0gc00536c

Non-toxic DAICs, especially lighter dimethyl- and diethyl-carbonate, are regarded as very green alkylating reagents, particularly when coupled with metal-exchanged Y- and X-faujasites as catalysts. These reactions are selective, free from wastes or byproducts, and often require no additional solvent other than the carbonate. Nonetheless, this paper demonstrates that the operating temperature and the nature of the faujasite must be carefully chosen in order to avoid DAIC decomposition. In fact, at temperatures ranging from 150 to 240 °C, faujasites can promote decarboxylation of light DAICs to the corresponding ethers CH₃OCH₃ and CH₃CH₂OCH₂CH₃ plus CO₂. Heavier DAICs (dipropyl- and dioctyl-carbonate) undergo a similar decomposition pathway, followed by further reactions to the corresponding alcohols (*n*-propanol and *n*-octanol) and alkenes [propylene and octene(s)]. These transformations not only consume DAICs, but also give rise to dangerously flammable ethers, as well as undesirable alcohols, alkenes and CO₂. The present work reports an original investigation of the decarboxylation of DAICs on faujasites with the aim of providing operative boundaries to the experimental conditions to minimise unwanted decomposition. The reaction is strongly affected by the nature of the catalyst: the more basic zeolites, NaX and CsY, are by far more active systems than NaY and LiY. However, solid K₂CO₃ proves to be rather inefficient. The temperature also plays a crucial role: for example, the onset of the decarboxylation of DMC requires a temperature of ~30 °C lower than that for DEC and DPrC. Overall, awareness that certain zeolites cause decomposition of DAICs under conditions similar to the ones used for DAIC-promoted alkylations allows determination of the correct experimental boundaries for a safer and more productive use of DAICs as alkylating agents.

Introduction

Light dialkyl carbonates (ROCO₂R, DAICs, R = C₁–C₃), especially dimethyl carbonate (DMC), are excellent green substitutes of toxic reagents and solvents.¹ Thanks to their dual electrophilic reactivity at both the carbonyl and the alkyl carbons, they find major applications in organic synthesis as safe building blocks for the replacement of phosgene and alkyl halides in carboxyalkylation and alkylation processes.^{1,2} In addition, their solvency properties – recently reviewed by Börner *et al.*³ – clearly indicate that DAICs should always be taken into consideration as alternative media for new transformations. In this context,

the combination of DAICs with a class of zeolites, namely alkali metal exchanged faujasites as catalysts,⁴ has proven to be successful to improve the outcome of several *O*- and *N*-alkylation reactions of different nucleophiles.⁵ As an example, Scheme 1 details some DMC-mediated methylations carried out in the presence of NaY or NaX faujasites. Two significant aspects emerge: (i) The use of zeolites steers the reaction towards an exclusive methylation process, for example eqn (a) and (b) show that both anilines and benzyl-type alcohols, even when deactivated by steric or electronic effects, yield only the corresponding *N*- and *O*-methyl derivatives.

An added value for amines is the very high selectivity (up to 98% at complete conversion) towards mono-*N*-methyl anilines, which cannot be otherwise achieved using conventional alkylation methods. (ii) Faujasite catalysts allow an excellent chemoselectivity in the methylation of ambident nucleophiles. Scheme 1 (left) exemplifies the case of aminophenols, aminobenzoic acids, hydroxybenzyl alcohols, and hydroxythiophenols [eqn (c)–(f), respectively], whose reactions with DMC proceed *via* a complete discrimination between the two nucleophilic terms of the substrates: methylation reactions take place at

Dipartimento di Scienze Molecolari e Nanosistemi dell'Università Ca' Foscari Venezia, Calle Larga S. Marta, 2137–30123, Venezia, Italy.
E-mail: selva@unive.it

† Electronic supplementary information (ESI) available: (i) A synopsis of MS signals for major gaseous and liquid products, including DME, CO₂, propylene, diethyl ether, dipropyl ether, isomeric octenes, and glycidol; (ii) an IR spectrum for a reaction mixture from the decarboxylation of DMC, including dimethyl ether, CO₂, and DMC. See DOI: 10.1039/c0gc00536c

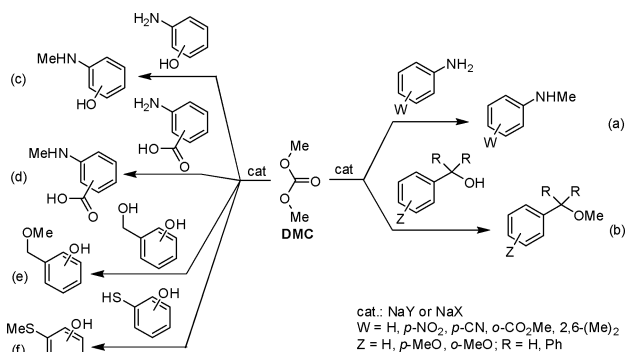

Scheme 1 DMC-mediated methylations in the presence of faujasite catalysts.

the amine, alcohol, or thiol groups, while the aromatic OH substituents as well as the acid functions are fully preserved from possible alkylation or transesterification processes. Although these transformations are relatively energy intensive (they usually occur at 150–200 °C), DMC acts not only as a safe alkylating agent, but also as a reaction solvent, and no by products except for MeOH and CO₂ are obtained.

The investigation of these reactions indicates that the formation of the desired alkylation products may take place through two concurrent mechanisms. This is especially true for alcohols whose etherification with DAICs over faujasites, proceeds through a sequence of tetrahedral and S_N2-type processes followed by a decarboxylation reaction.^{5d} Scheme 2 describes the reaction of benzyl alcohol with DMC.

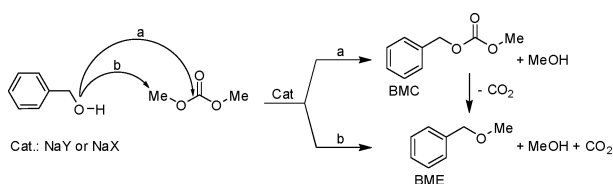

Scheme 2

Initially, benzyl methyl carbonate (BMC) and benzyl methyl ether (BME) originate from the attack of benzyl alcohol at both the carbonyl and methyl carbons of DMC [paths a and b, respectively]. Then, if the mixture is allowed to react further, BMC undergoes a quantitative decarboxylation and BME is obtained as a sole product in isolated yields up to 96%.

An intriguing question arises from this example: if reaction conditions allow BMC to lose CO₂, then would the decarboxylation of DMC be possible as well? If so, this raises a rather detrimental issue: an undesired consumption of the alkylating agent/solvent (DMC) would take place along with the co-generation of CO₂ in addition to that formed by the alkylation reaction (Scheme 2, path b). Moreover, this behavior would also open a more general window on the scope and limitations of the combined use of dialkyl carbonates and faujasites; in fact, higher homologues such as DEC and DPrC, would be expected to react similarly to DMC. One concludes that for a more productive use of light DAICs as alkylating agents, their decarboxylation – if occurring – should be avoided or minimized as much as possible.

Table 1 Faujasite catalysts used in the reaction of DMC

Starting zeolite (Na %) ^a	Product	Ionic exchange (%) ^b
NaY (8)	LiY	67
NaY (8)	CsY	56

^a The Na content was evaluated through atomic adsorption (AA). ^b The percentage of ionic exchange (from NaY) was evaluated by atomic adsorption (Na) and emission (Li and Cs).

It should be noted that the decarboxylation of organic carbonates is documented in the literature: for example, Pd-complexes catalyze the transformation of allyl alkyl carbonates to unsaturated esters and ketones,⁶ thermal treatment and/or basic/radical initiators induce the loss of CO₂ from carbonate polymers and alkyl aryl carbonates to produce mixtures of olefins, alcohols and polyether diols,^{14,7} hydrotalcite or alumina catalysts allow the synthesis of dialkyl ethers from heavy (C₁₀–C₂₁) dialkyl carbonates.⁸ However, to the best of our knowledge, an investigation of the behavior of light dialkyl carbonates with respect to the decarboxylation reaction has never been reported particularly in the presence of zeolite systems. This paper clearly demonstrates that such a reaction can proceed extensively when dimethyl-, diethyl-, and dipropyl-carbonates (DMC, DEC, and DPrC, respectively) are the substrates and alkali metal-exchanged Y and X faujasites (NaY and NaX) are the catalysts. The corresponding ethers have been observed in all cases though the onset of the decarboxylation is affected by the structure of carbonate and the nature of the zeolites. For a more complete comparison, also different catalysts such as hydrotalcite and K₂CO₃, and reagents such as dioctyl- and glycerol-carbonates have been examined. A mechanistic hypotheses is formulated on the basis of the adsorption of DMC over the NaY surface. Overall, this systematic study of the experimental conditions for the decarboxylation of light DAICs provides accurate boundaries to circumvent the reaction, and as a consequence, to improve substantially the outcome of DAICs-mediated alkylations.

Results

Catalysts

Four different faujasites, namely MY (M = Li, Na, Cs) and NaX were used as catalysts. Two of them, NaY and NaX, were commercially available samples. LiY and CsY were prepared through conventional ionic exchange reactions, starting from NaY and LiCl or CsCl as precursors.⁹ The metal content of the catalysts was determined by atomic adsorption (Na) and emission (Li, Cs), performed according to known procedures¹⁰ (Table 1). Hydrotalcite (HT: KW2000, Mg_{0.7}Al_{0.3}O_{1.15}) and K₂CO₃ were also from commercial suppliers.

Reaction of dimethyl carbonate over faujasites, hydrotalcite, and K₂CO₃

DMC was used as a model substrate to begin the investigation. Before each reaction, the catalysts (faujasites, hydrotalcite, and K₂CO₃) were dehydrated under vacuum (8 mbar) at 70 °C overnight. Initial experiments were carried out in a 120 mL

autoclave charged with a mixture of DMC (10 mL, 119 mmol) and the faujasite (0.6 g of NaY or NaX; the weight ratio, Q , catalyst : DMC was 0.056), and heated under stirring for 6 h at different temperatures of 150–220 °C.¹¹ Under these conditions, hydrotalcite (HT: 0.6 g) was also tested as a catalyst.¹² Once cooled to rt, a residual pressure up to 20 bar was measured inside the reactor. In order to recover the gaseous products of the reaction, a dedicated experimental setup was arranged: the autoclave was purged by a low temperature trap-to-trap apparatus (see Experimental for further details). The gaseous mixture was collected in an air-tight Drechsel bottle (200 mL) and weighed. Both the gas phase and residual liquid in the autoclave were analysed by GC-MS. In the first one (gas), only two products, CO₂ and dimethyl ether (DME), were observed.¹³ This unambiguously proved that the DMC underwent a decarboxylation reaction (Scheme 3).

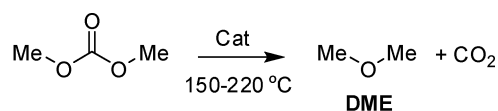

Cat.: NaY or NaX

Scheme 3

The progress of such a reaction was evaluated from the total (weighed) amounts of CO₂ and DME: this allowed to calculate the conversion of DMC in each experiment. The results are reported in Fig. 1.

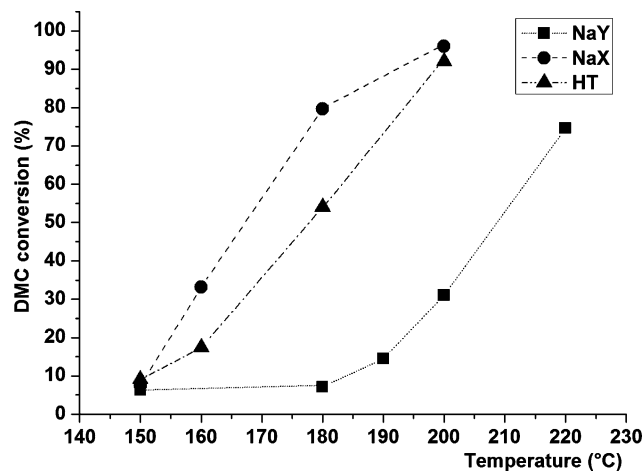

Fig. 1 Decarboxylation of DMC over sodium faujasites (NaY and NaX) and hydrotalcite (HT) at different temperatures and after 6 h.

Although the three catalysts were all effective for the decarboxylation of DMC, their performance was quite different. For example, at 180 °C, the reaction conversion was of 80%, 54%, and 7%, over NaX, HT, and NaY, respectively. In the same order, at 200 °C, the unreacted DMC was 4%, 8%, and 31%. These results indicated a preliminary trend of catalytic activity: NaX > HT > NaY.

The GC-MS analysis of the residual DMC in the autoclave showed traces of methanol whose amount did not exceed 3% even at high conversions (up to 90%). The presence of the alcohol was ascribed to hydrolysis of the starting carbonate, due to water adsorbed on the catalysts.⁸

Fig. 1 indicated that NaY faujasite allowed sufficiently slow reactions with well distributed conversions (6–75%) over a broad range of temperature (150–220 °C). Therefore, the results with NaY seemed a convenient choice to compare the activity of different catalysts. The investigation was extended to Li- and Cs-exchanged Y faujasites and K₂CO₃.¹⁴ Under the conditions above described (DMC: 10 mL; weight ratio Q = cat/DMC = 0.056), reactions were performed at 200 °C for 6 h. An additional experiment was carried out in the absence of any catalyst. The results are reported in Fig. 2, where for a more complete view the cases of NaY, NaX and HT are also included.

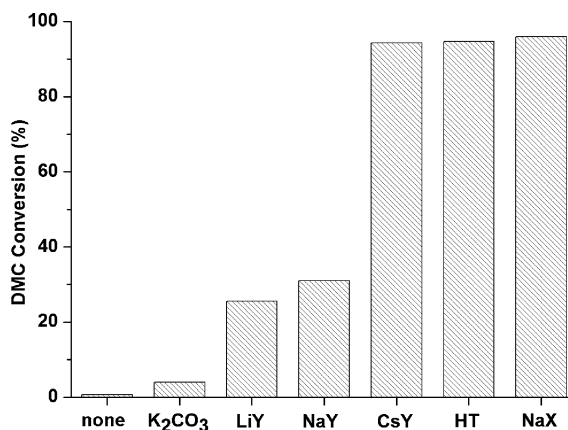

Fig. 2 Decarboxylation of DMC over different catalysts at 200 °C.

DMC by itself was rather stable to the decarboxylation. The reaction was observed only in the presence of a catalyst, and in all experiments CO₂ and dimethyl ether were the sole detected products (Scheme 3). However, the outcome was greatly affected by the nature of the added solid: the conversion of DMC was very modest (4%) on K₂CO₃, while it progressively raised from 26% to 94% with the increase of the basic character of Y-faujasites, *i.e.* from LiY to NaY and to CsY, respectively. This latter (CsY) offered an activity comparable to that of NaX and HT.

Importantly, results of both Fig. 1 and 2 also provided an indicative threshold temperature, below that the decarboxylation of DMC was negligible over different catalysts. This marked operative limits where DMC can be safely and efficiently used as an alkylating agent without significant decomposition and without formation of CO₂.

Effect of the faujasite amount and of the reaction time on the decarboxylation of DMC

Commercial NaY and NaX catalysts were chosen to continue the investigation. Two sets of experiments [(a) and (b)] were carried out: (a) at 200 °C and for 6 h, DMC (10 mL, 119 mmol) was set to react with increasing quantities of both NaY and NaX, by varying the weight ratio Q = cat : DMC from 0.015 to 0.084; (b) at 200 °C, a mixture of DMC (10 mL, 119 mmol) and the catalyst (NaY or NaX; Q ratio = 0.056), was set to react at different times, from 1 to 18 h, respectively. The results are shown in Fig. 3(a) and (b), respectively. Both sets of reactions confirmed that NaX was by far, a more active catalyst than NaY.

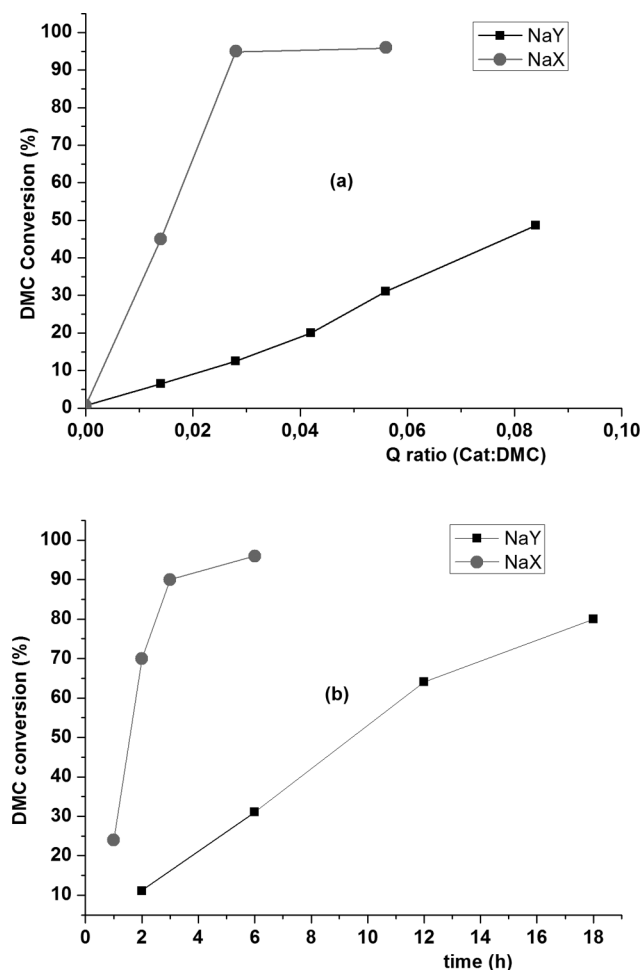

Fig. 3 The decarboxylation of DMC carried out at 200 °C, over NaY and NaX. (a) effect of the catalyst amount; (b) effect of the reaction time ($Q = 0.056$).

Fig. 3a [top; set (a)] proved that the decarboxylation of DMC was a truly catalytic process affected by the zeolite loading: the reaction conversion smoothly increased from 7 to ~50% as the NaY amount was augmented by a factor of 6 ($Q = 0.084$). By contrast, even with a modest Q ratio of 0.028, the use of NaX allowed a substantially quantitative conversion.

Fig. 3b [bottom; set (b)] showed the effect of the reaction time: at a Q ratio of 0.056, the decarboxylation process was complete in ~3 h in the presence of NaX (gray profile), while even after 18 h, 20% of the initial DMC was still unreacted when NaY was the catalyst (black profile).

The conversion of DMC was always determined by the weighed amounts of the reaction products (CO_2 and DME).

In order to test whether the thermal activation of faujasites affected their performance, two aliquots of NaY were heated in a stream of dry air (10 mL min^{-1}), at 200 and 400 °C, respectively, for 4 h. Then, these samples were used as catalysts to carry out two additional reactions with DMC at 200 °C, for 6 h. The weight ratio $Q = \text{NaY:DMC}$ was set to 0.056. In both cases, the reaction conversion (~30%) did not appreciably differ from that evaluated when the catalyst was simply dried at 70 °C (compare Fig. 1, 2, and 3a).

Competitive methylation and decarboxylation reactions over NaX

Fig. 1–3 and Table 1 proved that extensive decarboxylation of DMC took place under the same conditions used to carry out several methylation reactions mediated by DMC and catalyzed by faujasites (Scheme 2). This led to the plausible hypothesis that dimethyl carbonate could exhibit its methylating activity while, simultaneously, it underwent a decarboxylation reaction. An experiment was performed to verify such an aspect. A mixture of benzyl alcohol (5.0 mL, 48.4 mmol), DMC (15.0 mL, 178.2 mmol), and NaX (0.52 g; $Q = \text{cat} : \text{DMC} = 0.032$) was set to react at 200 °C, in a 120 mL autoclave, for 12 h. Once cooled to rt, the reactor was purged according to the procedure above mentioned (Fig. 1): a mixture of gaseous products (13.3 g) composed of CO_2 and DME, was recovered. The GC-MS analysis of the residual slurry content of the reactor revealed that the starting benzyl alcohol was totally converted as shown in Scheme 2.¹⁵ These results confirmed the competitive occurrence of the decarboxylation of DMC and the *O*-methylation of the alcohol: the two processes consumed ~70% and 25%, respectively, of the initial DMC amount.

Reaction of diethyl- and dipropyl-carbonates over Na-faujasites

The reactions of higher homologues of DMC such as diethyl- and dipropyl-carbonates (DEC and DPRC, respectively), were investigated in the presence of NaX and NaY faujasites. Before each run, both catalysts were carefully dehydrated under vacuum (8 mbar) at 70 °C, overnight. Experiments were carried out in the same 120 mL autoclave used for DMC.

In the case of DEC, a mixture of the carbonate (10 mL, 83 mmol) and the faujasite (0.55 g of NaY or NaX; the weight ratio, Q , catalyst : DEC was 0.056), was set to react for 6 h at different temperatures of 180–240 °C. Once cooled to rt, the reactor was dipped in a cooling bath at –55 °C, and vented. A GC-MS analysis of the released gas showed the sole presence of CO_2 . The autoclave was allowed to return gradually to ambient temperature, and the reaction mixture was analyzed by GC-MS. Diethyl ether (DEE) was observed as the main product (90–93%), confirming that also the decarboxylation of DEC took place over Na-faujasites (Scheme 4).

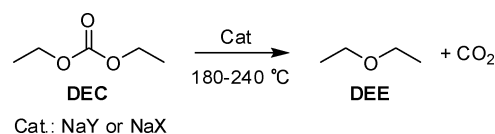

Scheme 4

Minor amounts (3–5%) of ethanol were detected as a by-product. Fig. 4 reports the conversion of DEC and the selectivity towards the formation of DEE (both parameters evaluated by GC-MS) vs. the reaction temperature.

Two aspects emerged: (i) the performance of the two faujasites resembled that shown for DMC. At comparable conditions, the DEC conversion was always higher over NaX with respect to NaY (black profiles); (ii) the onset of the decarboxylation of DEC required a temperature ~30 °C higher than that for DMC (compare Fig. 1). In other words, diethyl carbonate appeared

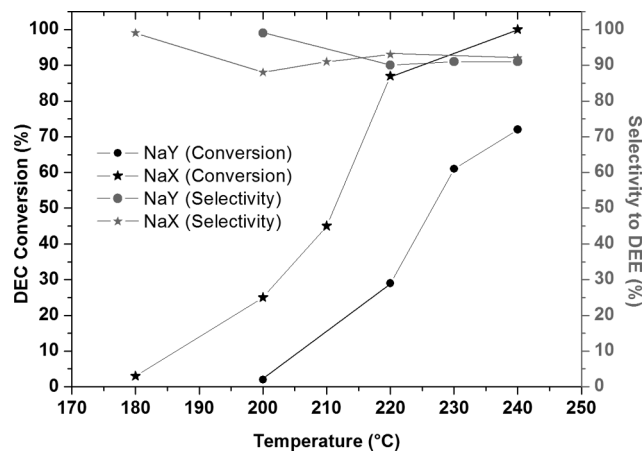
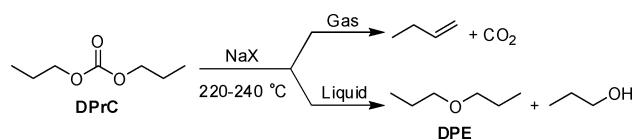

Fig. 4 Decarboxylation of DEC over NaY and NaX faujasites.

less prone than DMC to the loss of CO₂. The selectivity to DEE was, on average, very high (>90%, gray profiles); though, as for DMC, a minor hydrolysis of DEC due to water adsorbed on the faujasites yielded ethanol as a co-product.

Dipropyl carbonate (DPrC) was prepared by adjusting a general procedure reported for the synthesis of dialkyl carbonates.¹⁶ The reaction of DPrC was carried out using the procedure above described for DEC, only in the presence of the more active NaX as the catalyst: the carbonate (8.8 mL, 56 mmol) and the faujasite (0.3 g of NaX; the weight ratio, *Q*, catalyst : DPrC was 0.036), was set to react at temperatures of 220 and 240 °C for 6 and 12 h, respectively. The GC-MS analysis of the reaction products showed that the outcome of these experiments was remarkably different from that of DMC and DEC. DPrC underwent the expected decarboxylation reaction, though the process was no longer selective on formation of the corresponding ether. Regardless of the conversion of DPrC, the gas vented from the autoclave was a mixture of CO₂ and propylene, while liquid products were *n*-propanol and di-n-propyl ether (DPE) (Scheme 5).



Scheme 5

At 220 °C, after 6 h, the liquid phase contained unreacted DPrC (61%) along with comparable amounts of *n*-PrOH and DPE (22 and 17%, respectively). The gas phase (2.0 g) was composed by CO₂ and propylene.¹⁷ Both propylene and *n*-PrOH formed even at a moderate conversion of the starting carbonate.

At 240 °C, the conversion of DPrC was complete after 12 h: a gaseous mixture (3.70 g) of propylene and CO₂, and a liquid mixture of *n*-propanol (62%) and DPE (38%) were recovered. A first observation was that the presence of such a remarkable amount *n*-propanol hardly derived from the hydrolysis of DPrC. If so, the required quantity of water (0.31 g, 17 mmol) adsorbed on the catalyst would have been comparable to the weight of the catalyst itself. A plausible explanation for

the formation of both propanol and propylene was instead, the cracking of DPE according to Scheme 6:¹⁸

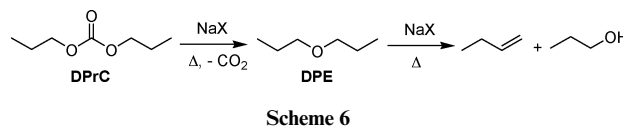

Scheme 6

This hypothesis was substantiated by the following considerations. The full decarboxylation of DPrC corresponded to the release of 56 mmol (2.45 g) of CO₂ which, from the total weight of gaseous products, allowed to calculate the formation of 30 mmol (1.25 g) of propylene. The stoichiometry of Scheme 6 indicated that the same molar amount (30 mmol) of *n*-propanol had to be present in the liquid products, thereby implying a residual (liquid) DPE quantity of 26 mmol. Accordingly, a propanol:DPE ratio of 65 : 35 was obtained in good agreement with the GC ratio (62 : 38) observed for these two compounds.

Other dialkyl carbonates

To verify whether the decarboxylation over Na-faujasites held true also for high molecular weight and/or viscous organic carbonates, two model compounds such as dioctyl carbonate (DOC) and glycerine carbonate (GlyC) were chosen.¹⁹ The reactions of DOC (2.0 g, 10.8 mmol) and GlyC (2.0 g, 17.0 mmol) were explored at 200 °C for 6 h, in the presence of NaX faujasite (the weight ratio, *Q*, catalyst : carbonate, was 0.06). In both cases, the viscosity of the reagents required the use of a solvent: cyclohexane (9 mL) and dimethoxyethane (9 mL) were used for DOC and GlyC, respectively. Experiments were carried out according to the procedure detailed for DEC.

In the case of DOC, the GC-MS analysis of the reaction mixture showed the presence of unreacted carbonate (42%), dioctyl ether (7%) and comparable amounts of *n*-octanol and isomeric octenes (28 and 23%, respectively,²⁰) (Scheme 7).

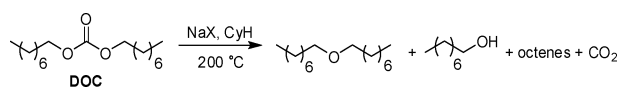

Scheme 7

The good analogy with the behavior of DPrC (Scheme 5) indicated that also the decarboxylation of DOC took place along with the plausible decomposition of the corresponding dioctyl ether to octanol and octenes. The reaction of GlyC instead, did not offer any clear interpretation: a complex mixture of several products was observed, most of them remained unidentified compounds. However, glycerol and trace amounts (5%) of glycidol were detected (Scheme 8).

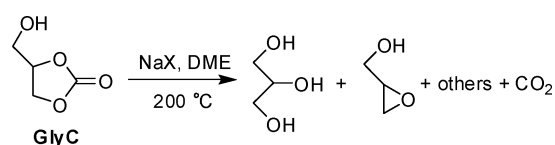

Scheme 8

Discussion

The decarboxylation of DMC and the nature of the catalyst

The formation of gaseous products during the decarboxylation of DAICs, particularly of DMC, requires a non-conventional experimental setup. In order to provide a complete reaction analysis, including conversions and yields, the whole apparatus must be designed not only to characterize final products, but also to recover them quantitatively. An accurate tuning/calibration of the system is required, especially for the balance between the scale of the reaction, the size of trapping bottles for gases, and vacuum cycles to be applied (details are given in the Experimental section). This technical barrier is perhaps one of the limitations why a detailed investigation for such a reaction was never previously reported for these substrates.

As far as the role of the catalyst, the adsorption phenomena of DMC over zeolites should be examined. Na-faujasites are often described as amphoteric catalysts due to the presence of basic oxygen atoms of aluminosilicate framework and weak Lewis acid metal cations.²¹ The latter in particular, are considered to be responsible for the interaction of dimethyl carbonate with the zeolite surface: according to IR and Raman investigations reported by us and by others,²² the adsorption of DMC over Na-faujasites takes place as shown in Scheme 9.

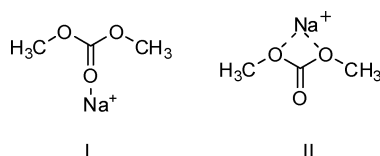

Scheme 9

DMC acts as a base to form acid–base complexes (I and II) with the Lewis acidic sites (Na⁺) of the catalyst. In both I and II species, the O–CH₃ and C–OCH₃ bonds are weakened. This fact implies an electrophilic activation of DMC after adsorption over faujasites, and in the last instance it can explain the catalytic activity of such solids in methylation/carboxymethylation reactions (Scheme 2).

The occurrence of adducts I and II also offers an interpretation for the decarboxylation reaction examined in this paper. Scheme 10 shows a plausible mechanistic hypothesis *via* a polar intra- and inter-molecular reactions (left and right, respectively). For simplicity only compound I is considered. The elongation of both O–CH₃ and C–OCH₃ bonds in the adsorbed DMC favours their cleavage with the extrusion of CO₂; the recombination (through a nucleophilic attack) of [−]OCH₃ and ⁺δCH₃ groups produces dimethyl ether. Whatever the mechanism, results of Fig. 1–3 leave no doubts about the superior catalytic efficiency of NaX with respect to NaY, for the decarboxylation of DMC.

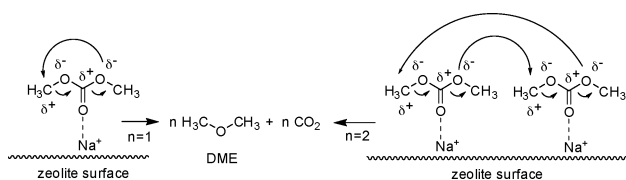

Scheme 10

More specifically, according to the acid–base scale proposed by Barthomeuf *et al.*,^{21,23} Fig. 2 shows that the increase of the reaction conversion is in good agreement with the trend of basic strength of faujasites: the more basic the zeolite (NaX ~ CsY > NaY ≥ LiY), the higher its decarboxylating activity. An hypothesis for this behaviour is based on the following reasoning. Alkali metal-exchanged faujasites, particularly the cheap and safe NaX and NaY, are claimed as some of the most effective adsorbents for CO₂ capture/storage:²⁴ they have an excellent potential reaching an adsorption efficiency up to 5.5 mmol of CO₂ per g of solid. Moreover, the affinity for carbon dioxide (under moderate pressures) has been demonstrated to increase with the basicity of the faujasites.^{24,25} In our case, this feature is expected to produce two opposite effects: (i) it plausibly facilitates the initial breakdown of DMC (DAIC) on NaX with respect to NaY (Scheme 3); (ii) it may determine a preferred saturation of the surface of more basic faujasites by CO₂ released from the decarboxylation reaction, which would lead to a drop of the catalyst activity. It should be noted, however, that CO₂ adsorption on zeolites is highly reversible (>90%) and the adsorption capacity decreases with a rise of temperature.²⁴ Under the investigated conditions (at around 200 °C), the dynamic of the adsorption process is likely to inhibit the saturation of the catalytic surface by CO₂, thus leaving a sufficient solid basicity to discriminate the activity of different faujasites.

It should be noted however, that the basicity *per se* is not a sufficient requisite for a rapid decarboxylation reaction. Solid K₂CO₃, in fact, is a rather poor catalyst (Fig. 2) probably because of its inefficiency in the adsorption of DMC. By contrast, the high conversion with hydrotalcite (HT, Fig. 2) is ascribable to the moderate amphoteric properties exhibited by this material.²⁶

The decarboxylation of higher dialkyl carbonates

In the case of diethyl- and dipropyl-carbonate, their adsorption over faujasites, their decarboxylation mechanism, as well as the relative catalytic activity of NaX and NaY (Fig. 4 for DEC), can be explained according to the discussion proposed for DMC.²⁷ The same holds for the selectivity in the reactions of DMC and DEC: the presence of alcohols (MeOH and EtOH) is compatible with minor hydrolysis of the two carbonates due to residual water adsorbed on the catalysts.²⁸ Major differences concern two aspects. (i) The loss of CO₂ from both DEC and DPnC is more energy intensive than for DMC. The corresponding decarboxylation reactions take place at 240 and 200 °C, respectively (compare Fig. 1a and 4). This result is consistent with the general trend observed for a number of alkylation and carboxyalkylation processes mediated by dialkyl carbonates, where a dramatic drop of reactivity always occurs if DMC is replaced with heavier DAICs (except for dibenzyl carbonate).^{1,2} An increase of the steric hindrance around both alkyl and carbonyl carbons of the reacting carbonates accounts for this behavior. (ii) The decarboxylation of DPnC is not a selective process. The expected product, dipropyl ether (DPE), forms along with two side compounds such as *n*-propanol and propylene (Scheme 5). Although some hydrolysis of DPnC is possible, this reaction hardly accounts for the sizable amount of the alcohol (up to 62%) detected in the liquid mixture.

Instead, the cracking of DPE catalyzed by NaX offers the most reasonable pathway to explain the presence of both *n*-propanol and propylene (Scheme 5). It should be noted that the conversion of dialkyl ethers to the corresponding olefins has been claimed in the literature, by using alkali and alkali earth metal-exchanged faujasites.¹⁷

In line with previous investigations,^{1,2,5} these results clearly exemplify how the reactivity of light DAICs, particularly DMC, can be remarkably different from that of their heavier homologues. A difference that may be determined also by the nature of the catalysts used. These considerations are further corroborated by the behavior of dioctyl-carbonate (DOC). Although the presence of a reaction solvent (CyH) does not allow a direct comparison with DPrC, the reaction of DOC catalyzed by NaX shows a product distribution quite similar to DPrC, yielding dioctyl ether, *n*-octanol and isomeric octenes (Scheme 7). At 180–250 °C, the decarboxylation of DOC has been described also with a hydrotalcite catalyst.⁸ In this case however, reaction products were only dioctyl ether and *n*-octanol: the authors did not observe octene(s) and the formation of the alcohol (up to 20% at complete conversion) was attributed to the hydrolysis of the reactant carbonate.

Dimethyl ether (DME) – due to its structure – generated in the reaction of DMC, cannot decompose according to the cracking reaction of Scheme 6. Also the hydrolysis of DME to MeOH is not a plausible process: this requires a very high temperature (usually ≥ 300 °C), strongly acid catalysts and a water(steam)/DME ratio > 2.5 ,²⁹ clearly not compatible with conditions here investigated. Therefore, the presence of water adsorbed on the catalyst is unlikely to alter the product distribution in the reaction of DMC. In this respect, it should also be noted that the conversion of DMC is not affected by different thermal treatments (at 70, 200, and 400 °C, respectively) used for NaY catalyst: from the mechanistic standpoint, this suggests that (different) amounts of water adsorbed by the faujasite do not enter the decarboxylation step of DMC.

In the reaction of DEC, not even trace amounts of ethylene are observed, meaning that diethyl ether (DEE) does not decompose over the catalyst. No clear reasons account for this behavior, though the trend of alkene stability ($\text{RCH}=\text{CHR} > \text{CH}_2=\text{CHR} > \text{CH}_2=\text{CH}_2$) can play a role.³⁰ Alike to DME, also the hydrolysis of DEE to EtOH should not occur under the examined conditions.

Conclusions

The combined use of dialkyl carbonates (DAICs) and alkali metal exchanged faujasites is a powerful synthetic tool to promote the alkylation of a number of *N*-, *O*-, and *S*-nucleophiles with excellent selectivities, above 95%, at quantitative conversions. However, this paper demonstrates that the experimental conditions, especially the high temperature often required for such processes, may also trigger important side reactions: in the range of 150–240 °C, a decarboxylation of the reactant dialkyl carbonates may take place concurrently to the desired alkylation reactions. Furthermore, the decarboxylation of DAICs may be followed by other processes whose occurrence is strictly dependent on the nature of DAICs. In particular, dimethyl- and diethyl-carbonate undergo the loss of CO₂ to produce the

corresponding dimethyl and diethyl ethers in a very high yield. Heavier carbonates instead, give different products: dipropyl carbonate provides a mixture of dipropyl ether, *n*-propanol and propylene; likewise, dioctyl carbonate provides dioctyl ether, *n*-octanol, and octene(s), respectively. The mechanism of adsorption of DMC over Na-faujasites, offers a rationale to discuss the onset of the decarboxylation reaction, while the acid–base properties of zeolites allow an interpretation for the catalytic activity of the tested catalysts: the more basic the faujasite, the better its capability to favor the release of CO₂ during the reaction, the better its performance. In the case of dipropyl- and dioctyl-carbonate, once decarboxylation takes place, cracking of the corresponding dialkyl ethers catalysed by Na-faujasites is a plausible pathway to explain the presence of alcohols and alkenes as co-products.

Overall, the results reported in this work, highlight two significant aspects: they elucidate the possible limitations of the use of dialkyl carbonates in the presence of faujasite catalysts and they offer boundaries to the reaction conditions, *i.e.* temperature and nature of the catalysts, in order to avoid side reactions by which an extensive consumption of DAICs may take place along with the formation of highly flammable ethers such as DME and DEE, and the co-generation of undesired CO₂. In order to control the efficiency and safety of DAICs-promoted alkylations, one must be aware that a threshold temperature for decomposition of organic carbonates should be established case by case for any given catalytic system.

Finally, water adsorbed on faujasites does not seem to have a role on the decarboxylation of DAICs.

Experimental

General

All reagents used [K₂CO₃, dimethylcarbonate (DMC), diethylcarbonate (DEC), glycerine carbonate (GlyC), dimethoxyethane (DME), cyclohexane, *n*-propanol, propyl chloroformate, and *n*-octanol] were ACS grade and were employed without further purification. GlyC was a generous gift from Huntsman Corporation. Faujasites NaY and NaX were commercial samples from Aldrich (art. # 334448 and 28,359-2); LiY and CsY were synthesized from NaY by an ion exchange using LiCl and CsCl precursors.^{9a} The percentage of ion exchange was determined according to a method previously reported by us:^{9b} based on the initial Na content, the % exchange was 67% and 56%, for Li and Cs, respectively. Hydrotalcite KW2000 was from Kyowa Chemical Industry Co. Tokyo, (Mg_{0.7}Al_{0.3}O_{1.15}) with a specific surface area 202 m² g⁻¹. The catalysts (faujasites, hydrotalcite, and K₂CO₃) were stored under vacuum (8 mbar) at 70 °C. In two additional experiments, two samples of NaY were activated in a stream of dry air (10 mL min⁻¹), at 200 and 400 °C, respectively. GC-MS (EI, 70 eV) analysis were run using a HP5/MS capillary column (30 m). The infrared spectra have been recorded on the Bruker Vertex 70 FTIR spectrometer equipped with a Ge/KBr beamsplitter, a Global source, and a DTGS detector.

Dipropyl carbonate (DPrC)

DPrC was prepared by adjusting a general method for the synthesis of dialkyl carbonates:¹⁵ a 250 mL 2-necked flask

equipped with a condenser and a dropping funnel, was charged with a mixture of *n*-propanol (0.33 mmol, 20 g) and pyridine (0.34 mmol, 27 g). The flask was cooled at 0 °C and propyl chloroformate (0.31 mmol, 38 g) was added dropwise under vigorous stirring. The mixture was allowed to reach rt. Then, aq. HCl (5%, 30 mL) was added. The organic phase was extracted with diethyl ether (2 × 120 mL), and dried over Na₂SO₄. The product DPrC was distilled (bp = 83 °C/86 mbar; Y = 35 g, 77%) and characterized by GC-MS and ¹H NMR.

¹H NMR (CDCl₃, 400 MHz) δ (ppm): 4.07 (t, 4H, *J* = 6.7 Hz), 1.68 (m, 4H), 0.95 (t, 6H, *J* = 7.4 Hz). GC-MS (EI, 70 eV), *m/z*: 146 ([M]⁺, <1%), 63 (42), 59 (27), 43 (100), 42 (16), 41 (28). Spectroscopic properties were in agreement with those of an authentic commercial sample of DPrC.

Diocylcarbonate (DOC)

DOC was prepared by the transesterification reaction of *n*-octyl alcohol with DMC, accordingly to a procedure already reported.⁸ Starting from 26 g (0.2 mol) of *n*-octanol, DOC was isolated in a 68% yield (20 g) and characterized by GC-MS and ¹H NMR.

¹H NMR (CDCl₃, 400 MHz) δ (ppm): 4.11 (t, 4H, *J* = 6.7 Hz), 1.65 (m, 4H), 1.33 (m, 20H), 0.87 (t, 6H, *J* = 6.8 Hz). GC-MS (EI, 70 eV), *m/z*: 286 ([M]⁺, <1%), 113 (32), 84 (22), 83 (26), 71 (100), 70 (33), 69 (37), 57 (74), 56 (35), 55 (46), 43 (49), 42 (24), 41 (64). Spectroscopic properties were in agreement with those reported in the literature.⁸

The decarboxylation of DMC: general procedure

A 120 mL stainless steel autoclave fitted with two valves, a pressure gauge and a thermocouple for temperature control, was charged with DMC and the catalyst. The autoclave was closed and, after a careful air removal by 3 vacuum/N₂ cycles, it was electrically heated at the desired temperature. The reaction mixture was kept under magnetic stirring throughout the experiments. The following conditions and amounts of DMC/catalyst were used.

Figure 1: 10 mL (10.7 g, 119 mmol) of DMC and 600 mg of the catalyst (weight ratio, *Q*, catalyst : DMC = 0.056). Catalysts were NaX and NaY faujasites, and hydrotalcite (HT: KW2000). The reaction temperature was in the range of 150–220 °C, and the reaction time was 6 h.

Figure 2: 10 mL (10.7 g, 119 mmol) of DMC and 600 mg of the catalyst (weight ratio, *Q*, catalyst : DMC = 0.056). Six catalysts were used: LiY, NaY, CsY and NaX faujasites, hydrotalcite (HT: KW2000), and K₂CO₃. The reaction temperature was 200 °C and the reaction time was 6 h.

Figure 3a: 10 mL (10.7 g, 119 mmol) of DMC were set to react with increasing quantities of both NaY and NaY. The weight ratio, *Q*, catalyst : DMC was varied from 0.015 to 0.084. The reaction temperature was 200 °C and the reaction time was 6 h.

Figure 3b: 10 mL (10.7 g, 119 mmol) of DMC and 600 mg of the catalyst (weight ratio, *Q*, catalyst : DMC = 0.056). Catalysts were NaY or NaX faujasites. The reaction temperature was 200 °C, and the reaction time was in the range of 1–18 h.

At the end of each experiment, the autoclave was cooled at room temperature. In order to recover the gaseous products of the reaction, CO₂ and dimethyl ether (DME), the autoclave was

purged by a low temperature trap-to-trap apparatus. The system is outlined in Fig. 5.

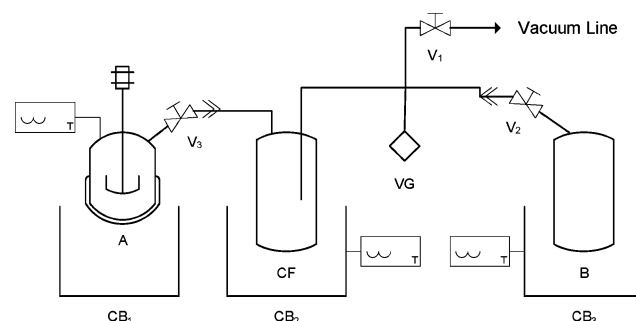

Fig. 5 The apparatus used for the recovery of gaseous CO₂ and dimethyl ether. A: autoclave; CB: cooling bath; CF: cold finger; B: air-tight Drechsel bottle; V: valve; VG: vacuum gauge; T: temperature control.

A vacuum line was equipped with a cold finger (250 mL, CF) and a Drechsel bottle (250 mL, B). By valves V₁–V₂, the whole system was set to a pressure ≤1 Torr. This was continuously monitored by a vacuum gauge (VG). Then, the autoclave (A) containing the reaction mixture, the finger CF, and the bottle B were simultaneously dipped in three cooling baths (CB₁, CB₂, and CB₃) set at –60 °C, –196 °C, and –196 °C, respectively. The valves V₁–V₂ were closed and the autoclave was connected to CF by opening V₃; once the pressure of the system reached a constant value (~150 Torr), V₁ was opened to vent N₂ charged in the reactor at the beginning of the experiment. Then, V₁ was closed and the bath CB₁ was brought to –20 °C. At this temperature, V₃ allowed to purge the reaction products, CO₂ and DME, from the autoclave. Both compounds were condensed in CF along with a very small fraction (≤0.5 mL) of the residual DMC. V₃ was closed and acetone was added to the bath CB₂ until it reached –50 °C. Then, V₂ was opened to convey selectively CO₂ and DME from CF to the bottle B, while DMC remained in CF. Eventually, V₃ was closed. The bottle B was disconnected from the vacuum line, allowed to return gradually to ambient temperature, and weighed. The gaseous mixture in the bottle was then analysed by GC-MS.

The conversion of DMC reported in Fig. 1–3 was calculated by the total mass (and molar) amounts of CO₂ and DME, according to the stoichiometry given in Scheme 3. MS spectra of both CO₂ and DME gave a match quality higher than 97% when compared to standard products of the Wiley-MS database.³¹ The structure of DME was further confirmed by the comparison of the IR spectrum of the reaction mixture with that of an authentic sample of DME (details are given in the ESI†).

The decarboxylation of DEC and DPrC

The decarboxylation of both DEC and DPrC were carried out according to the procedure described for DMC. The following conditions and amounts of dialkyl carbonate/catalyst were used.

DEC, Figure 4: 10 mL (83 mmol) of DEC and 550 mg of the catalyst (weight ratio, *Q*, catalyst : DEC = 0.056). Catalysts were NaX and NaY faujasites. The reaction temperature was in the range of 180–240 °C, and the reaction time was 6 h. The GC-MS

analysis of the gas phase showed the presence of CO₂ as a sole product: its (weighted) mass amount allowed calculation of the conversion of DEC.

The GC-MS analysis of the residual liquid mixture in the autoclave showed two products: diethyl ether (major, >90% at complete conversion) and ethanol (trace amounts, 3–5%). The analysis of the liquid phase also offered the possibility to determine the conversion of DEC whose values matched (within ±3%) those calculated from the weight of CO₂. The structure of diethyl ether and ethanol were confirmed by their mass spectra and by comparison with authentic commercial samples.

DPrC, Scheme 5: 8.8 mL (56 mmol) of DPrC and 300 mg of the faujasite (the weight ratio, *Q*, catalyst : DPrC = 0.036). The temperature was set at 220 and 240 °C for 6 and 12 h, respectively. CO₂ and propylene were detected as gaseous products. MS spectra of both compounds gave a match quality higher than 95% when compared to standard products of the Wiley-MS database.³¹ However, the conversion of DPrC could not be estimated from the weighted amounts of CO₂ and propene.¹⁷

The GC-MS analysis of the residual liquid mixture in the autoclave showed two products: dipropyl ether (17–40%) and *n*-propanol (23–60%). The structure of dipropyl ether and *n*-propanol were confirmed by their mass spectra and by comparison with authentic commercial samples.

The reaction of dioctyl carbonate (DOC) and glycerol carbonate (GlyC)

The reaction of both DOC and GlyC were carried out with the same procedure used for DMC. However, due to the viscosity of the starting carbonates, a solvent was necessary. The following conditions and amounts of dialkyl carbonate/catalyst were used.

DOC, Scheme 7: 2.0 g (10.8 mmol) of DOC, 120 mg of NaX faujasite (the weight ratio, *Q*, catalyst : carbonate, was 0.06), and cyclohexane (9 mL) as solvent. The reaction temperature was set at 240 °C, and the reaction time was 6 h.

The GC-MS analysis of the gas phase showed CO₂ as a sole product. The GC-MS analysis of the residual liquid mixture in the autoclave showed the presence of unreacted DOC (42%), dioctyl ether (7%), *n*-octanol (28%), and isomeric octenes (mixture of 1-octene, 2-octene and other octenes: total of 23%). The structure of dioctyl ether, *n*-octanol, 1-octene and 2-octene was confirmed by their mass spectra and by comparison with authentic commercial samples.

GlyC, Scheme 8: 2.0 g (17 mmol) of GlyC, 120 mg of NaX faujasite (the weight ratio, *Q*, catalyst : carbonate, was 0.06), and dimethoxyethane (9 mL) as solvent. The reaction temperature was set at 240 °C, and the reaction time was 6 h.

The GC-MS analysis of the residual liquid mixture in the autoclave showed the formation of several products. Among them, glycerol (10–12%) and glycidol (3–5%) were detected. The structure of both compounds were confirmed by their mass spectra and by comparison with authentic commercial samples.

Acknowledgements

MIUR (Italian Ministry for Education, University and Research) is gratefully acknowledged for the financial support of

this work. Mr. Alessandro Baldan is also acknowledged for his support in IR spectra.

Notes and references

- (a) A.-A. Shaik and S. Sivaram, *Chem. Rev.*, 1996, **96**, 951–976; (b) P. Tundo and M. Selva, *Acc. Chem. Res.*, 2002, **35**, 706–716; (c) V. K. Ahluwalia, and M. Kidwai, In *New Trends in Green Chemistry*, Kluwer Academic and Anamaya Pub., New Delhi, India, 2004; (d) *Carbon Dioxide as Chemical Feedstock*, M. Aresta, Ed.; Wiley VCH, Weinheim, 2010, Ch. 7.
- (a) M. Selva, P. Tundo, A. Perosa and S. Memoli, *J. Org. Chem.*, 2002, **67**, 1071–1077; (b) A. Loris, A. Perosa, M. Selva and P. Tundo, *J. Org. Chem.*, 2004, **69**, 3953–3956; (c) M. Selva, P. Tundo, A. Perosa and F. Dall'Acqua, *J. Org. Chem.*, 2005, **70**, 2771–2777; (d) M. Selva, A. Perosa, P. Tundo and D. Brunelli, *J. Org. Chem.*, 2006, **71**, 5770–5773; (e) M. Selva and A. Perosa, *Green Chem.*, 2008, **10**, 457–464.
- B. Schaffner, F. Schaffner, S. P. Verevkin and A. Borner, *Chem. Rev.*, 2010, **110**, 4554–4581.
- Alkali metal exchanged Y- and X-faujasites are a class of zeolites in which the negative charge of the aluminosilicate framework is counterbalanced by an alkali metal cation. For example, NaY and NaX faujasites possess the same 3D-structure, but they differ for the Si/Al content. Their general formulas are Na₅₆[(AlO₂)₅₆(SiO₂)₁₃₆]-250H₂O and Na₈₆[(AlO₂)₈₆(SiO₂)₁₀₆]-264H₂O, respectively. For morphological details and other properties, see: (a) F. Schwochow and L. Puppe, *Angew. Chem., Int. Ed. Engl.*, 1975, **14**, 620–628; (b) G. C. Bond, in *Heterogeneous Catalysis Principles and Applications*, Oxford University Press, New York, USA, 2nd edn, 1987, pp. 104–110.
- (a) M. Selva, A. Bomben and P. Tundo, *J. Chem. Soc., Perkin Trans. 1*, 1997, 1041–1045; (b) M. Selva, P. Tundo and A. Perosa, *J. Org. Chem.*, 2003, **68**, 7374–7378; (c) M. Selva, P. Tundo and T. Foccardi, *J. Org. Chem.*, 2005, **70**, 2476–2485; (d) M. Selva and P. Tundo, *J. Org. Chem.*, 2006, **71**, 1464–1470; (e) M. Selva, E. Militello and M. Fabris, *Green Chem.*, 2008, **10**, 73–79; (f) M. Selva, A. Perosa and M. Fabris, *Green Chem.*, 2008, **10**, 1068–1077; M. Selva and M. Fabris, *Green Chem.*, 2009, **11**, 1161–1172.
- (a) J. Tsuji, K. Sato and H. Okumoto, *J. Org. Chem.*, 1984, **49**, 1341–1344; (b) J. Tsuji and I. Minami, *Acc. Chem. Res.*, 1987, **20**, 140–145.
- (a) D. A. Loy, J. V. Beach, B. M. Baugher, R. A. Assink, K. J. Shea, J. Tran and J. H. Small, *Chem. Mater.*, 1999, **11**, 3333–3341; (b) M. Wu, J. Guo and H. Jing, *Catal. Commun.*, 2008, **9**, 120–125; (c) Y. S. Park and W. K. Lee, *Bull. Korean Chem. Soc.*, 1997, **18**(4), 360–361.
- P. Tundo, F. Aricò, A. E. Rosamilia and S. Memoli, *Green Chem.*, 2008, **10**, 1182–1189.
- The ion exchange reaction was carried out as described by: (a) M. Onaka, K. Ishikawa and Y. Izumi, *Chem. Lett.*, 1982, 1783; (b) M. Selva, P. Tundo and A. Perosa, *J. Org. Chem.*, 2002, **67**, 9238–9247.
- Analytical Methods Manual*, Varian Inc., 1989.
- The temperature range (150–200 °C) was chosen according to the operating conditions usually employed for DMC-mediated methylation reactions.
- Hydrotalcite is an aluminium-magnesium hydroxycarbonate. Natural hydrotalcite possesses the general formula Mg₆Al₂(OH)₁₆CO₃·4H₂O. However, both Mg²⁺ and Al³⁺ can be isomorphously substituted by other metal ions, forming new hydrotalcite-like materials of general formula [M_{1-x}²⁺M_x³⁺(OH)₂]⁺A_{x/n}ⁿ⁻·mH₂O, where M denotes metal ions, A denotes exchangeable anions with valence *n*, and *x* is within 0.17–0.33. See, for example: A. Bhattacharyya, V. W. Chang and D. J. Schumacher, *Appl. Clay Sci.*, 1998, **13**, 317–328.
- It should be noted for clarity that at rt, a refluxing liquid was visible at the bottom of the Drechsel bottle. Once the bottle was opened, its content was completely released to the atmosphere. The liquid was compressed dimethyl ether (bp = 24.8 °C), as confirmed by the GC-MS analysis. In addition, this also explained why the GC response of the gaseous mixture showed a slight excess of CO₂: the ratio of CO₂/DME signals was, on average, 1.2.
- K₂CO₃ was reported as a catalyst for a number of DMC-mediated alkylations (see refs. 1–2). Therefore, the knowledge of the behavior of K₂CO₃ as a catalyst for the decarboxylation of DMC was rather important.
- A 9 : 1 mixture of benzyl methyl ether and dibenzyl ether [(PhCH₂)₂O; DBE] was obtained. The small amount (10%) of dibenzyl ether

- plausibly derived from two reactions, both catalyzed by the NaX faujasite: the dehydration of benzyl alcohol (see ref. 5d), and/or the transesterification of benzyl alcohol to dibenzylcarbonate (PhCH₂OCO₂CH₂Ph) followed by a decarboxylation process. In our case, the presence of DBE as a side-product left a minor uncertainty on the final conversion of DMC.
- 16 M. Matzner, R. P. Kurkij and R. J. Cotter, *Chem. Rev.*, 1964, **64**, 645–687.
- 17 Unfortunately, the GC signals of CO₂ and propylene could not be perfectly resolved and an estimation of the CO₂ amount was not possible. As a consequence, the conversion of DPrC could not be calculated from the weight of gaseous products.
- 18 (a) D. D. Rosenfeld, D. D. Pete, L. L. Iaccino, and B. Hammond, Exxon Chemical Company, WO/1993/025504 (December 23, 1993); (b) G. I. Cox, D. D. Pete, and D. D. Rosenfeld, Exxon Chemical Company, WO/1995/011209 (April 27, 1995).
- 19 (a) J. A. Kenar, G. Knothe, R. O. Dunn, T. W. Ryan III and A. Matheaus, *J. Am. Oil Chem. Soc.*, 2005, **82**(3), 201–205; (b) Huntsman, *Technical Bulletin* (http://193.221.91.170/performance_products/Media/JEFFSOL%20%AE_Glycerine_Carbonate.pdf).
- 20 Faujasites have been reported to catalyse the isomerization of olefins, see for example: Y. Ono and T. Baba, *Catal. Today*, 1997, **38**, 321–337.
- 21 (a) D. Barthomeuf, *J. Phys. Chem.*, 1984, **88**, 42–45; (b) D. Barthomeuf, *Catal. Rev.*, 1996, **38**(4), 521–612.
- 22 (a) T. Beutel, *J. Chem. Soc., Faraday Trans.*, 1998, **94**, 985–993; (b) F. Bonino, A. Damin, S. Bordiga, M. Selva, P. Tundo and A. Zecchina, *Angew. Chem., Int. Ed.*, 2005, **44**, 4774–4777.
- 23 B. Su and D. Barthomeuf, *Stud. Surf. Sci. Catal.*, 1995, **94**, 598–603.
- 24 (a) G. Maurin, P. L. Llewellyn and R. G. Bell, *J. Phys. Chem. B*, 2005, **109**, 16084–16091; (b) D. Bonenfant, M. Kharoune, P. Niquette, M. Mimeault and R. Hausler, *Sci. Technol. Adv. Mater.*, 2008, **9**, 013007.
- 25 S. V. Bordawekar and R. J. Davis, *J. Catal.*, 2000, **189**, 79–90.
- 26 (a) J. Shen, J. M. Kobe, Y. Chen and J. A. Dumesic, *Langmuir*, 1994, **10**, 3902–3908; (b) J. Shen, M. Tu and C. Hu, *J. Solid State Chem.*, 1998, **137**, 295–301.
- 27 To the best of our knowledge, the interactions of faujasites with dialkyl carbonates other than DMC have not been investigated so far. However, the adsorption of DEC, DPrC, and DOC on such catalysts is expected to proceed as for DMC, via the formation of acid–base complexes similar to those shown in Scheme 9.
- 28 Alkali metal faujasites of both X- and Y-type are hygroscopic solids, see: *Organic Solid State Reactions*, ed. F. Toda, Kluwer Academic Publishers, Dordrecht, The Netherlands, 2002, pp. 160–161.
- 29 (a) K. Faungnawakij, Y. Tanaka, N. Shimoda, T. Fukunaga, S. Kawashima, R. Kikuchi and K. Eguchi, *Appl. Catal., A*, 2006, **304**, 40–48; (b) K. Faungnawakij, R. Kikuchi, T. Fukunaga and K. Eguchi, *J. Phys. Chem. C*, 2009, **113**(43), 18455–18458.
- 30 J. McMurry, In *Organic Chemistry*, 6th Ed., Brooks Cole, Pub, 2003.
- 31 Wiley Library of Mass Spectral Data, 2002: software of the GC-MS instrument.