

Available online at [www.sciencedirect.com](http://www.sciencedirect.com)

SCIENCE @ DIRECT®

Catalysis Today 104 (2005) 323–328

[www.elsevier.com/locate/cattod](http://www.elsevier.com/locate/cattod)

# Preparation, performances and reaction mechanism for the synthesis of H<sub>2</sub>O<sub>2</sub> from H<sub>2</sub> and O<sub>2</sub> based on palladium membranes

S. Abate<sup>a</sup>, G. Centi<sup>a,\*</sup>, S. Melada<sup>b</sup>, S. Perathoner<sup>a</sup>, F. Pinna<sup>b</sup>, G. Strukul<sup>b,\*</sup><sup>a</sup> *Dipartimento di Chimica Industriale ed Ingegneria dei Materiali, University of Messina, Salita Sperone 31, 98166 Messina and INSTM Firenze, Italy*<sup>b</sup> *Dipartimento di Chimica, University of Venezia, Dorsoduro 213, 30123 Venezia and INTSM Firenze, Italy*

Available online 9 April 2005

## Abstract

A series of new tubular catalytic membranes (TCM's) have been prepared and tested in the direct synthesis of H<sub>2</sub>O<sub>2</sub>. Such TCM's are asymmetric  $\alpha$ -alumina mesoporous membranes supported on macroporous  $\alpha$ -alumina, either with a subsequent carbon coating (CAM) or without (AAM). Pd was introduced by two different impregnation techniques. Deposition–precipitation (DP) was applied to CAM's to obtain an even Pd particles distribution inside the membrane pore network, whereas electroless plating deposition (EPD) was successfully applied to AAM's to give a 1–10  $\mu$ m thick nearly-dense Pd layer. Both type of membranes were active in the direct synthesis of H<sub>2</sub>O<sub>2</sub>. Catalytic tests were carried out in a semi-batch re-circulating reactor under very mild conditions. Concentrations as high as 250–300 ppm H<sub>2</sub>O<sub>2</sub> were commonly achieved with both CAM's and AAM's after 6–7 h time on stream, whereas the decomposition rate was particularly high in the presence of H<sub>2</sub>. Important features are the temperature control and pre-activation. In order to slow down the decomposition and favor the synthesis of H<sub>2</sub>O<sub>2</sub> a smooth metal surface is needed.

© 2005 Elsevier B.V. All rights reserved.

**Keywords:** Hydrogen peroxide; Direct synthesis; Membrane; CMR; Palladium; Catalysis

## 1. Introduction

Hydrogen peroxide is a commodity which, today, is almost exclusively produced by the anthraquinone process [1]. This process is economically feasible only on large-scale plants. Additionally, the final price of H<sub>2</sub>O<sub>2</sub> produced is deeply influenced by the complexity of the process and by the costly separation and concentration steps needed. Direct synthesis, which could be a more economic and “green” alternative, has been known since the beginning of the XXth century [2] and many patents have been filed even during the last 30 years [3–11], however only a few scientific papers have been published in the open literature [12].

To date, no industrial application has ever been accomplished, even if some successful attempts have been

realized at DuPont during 1980's [3]. This is because two severe drawbacks have to be overcome: (i) the formation of explosive H<sub>2</sub>/O<sub>2</sub> mixtures that should be avoided and (ii) the selectivity of the reaction (whose main product is water) that should be improved. Recently, the use of especially designed catalytic membranes could have been suggested to overcome both problems [10–12].

## 2. Experimental

Two types of tubular membranes have been prepared, loaded with Pd and tested in the direct synthesis of H<sub>2</sub>O<sub>2</sub>.

### 2.1. $\alpha$ -Alumina asymmetric membranes (AAM)

These were supplied by Hermsdörfer Institut für Technische Keramik (HITK, Hermsdorf, Germany) and

\* Corresponding authors. Tel.: +39 090 39 3134; fax: +39 090 39 1518; mobile: 39 3921 992182.

E-mail addresses: [centi@unime.it](mailto:centi@unime.it) (G. Centi), [strukul@unive.it](mailto:strukul@unive.it) (G. Strukul).

consist of an  $\alpha$ -alumina macroporous support (3  $\mu\text{m}$  pore size) with a  $\alpha$ -alumina external mesoporous layer (pore size 50–100 nm). Pd was deposited on these membranes as a thin layer (1–10  $\mu\text{m}$  thick) by electroless plating deposition. This technique consists in subsequent steps of  $\text{Sn}^{2+}$  sensitizing and  $\text{Pd}^{2+}$  activations in order to form on the  $\alpha\text{-Al}_2\text{O}_3$  membrane surface Pd seeds active in the surface formation of  $\text{Pd}(\text{NH}_3)_4^{2+}$  complexes, which could be subsequently decomposed by chemical reduction in order to form on the membrane a homogeneous Pd film. After that, a thermal treatment at 500 or 800  $^\circ\text{C}$  in inert atmosphere gave the final membrane.

## 2.2. Carbon coated alumina membranes (CAM)

The second type of membrane was a carbon coated  $\alpha$ -alumina membrane (CAM) which was impregnated by a deposition–precipitation method (a classical method to obtain egg-shell type catalysts) [13–15]. Carbon coating was accomplished by MAST Carbon Ltd. (Guildford, UK) on the same asymmetric  $\alpha\text{-Al}_2\text{O}_3$  membrane used for AAM's preparation. This technique consisted in making the membrane surface alkaline with a NaOH solution (0.1 M) prior to putting in contact with an acidic  $\text{PdCl}_4^{2-}$  solution (40 ppm  $\text{Pd}^{\text{II}}$ , pH 0.7). During impregnation  $\text{Pd}(\text{OH})_2$  deposited into the pore network of the carbon layer. After Pd deposition, membranes were dried at room temperature, reduced in  $\text{H}_2$  flow and washed with distilled water to remove the chloride ions. Pd loading was between 1 and 2 wt.% with respect to the total carbon amount.

## 2.3. Characterization

Both types of membranes were characterized by electron microscopy, physisorption and chemisorption methods either after reduction or subsequent  $\text{H}_2\text{O}_2$  oxidation treatment. Carbon coated membranes have been broken into small pieces (5–10 mm) before  $\text{N}_2$  physisorption. Pre-

treatment was carried out in rotative pump vacuum level by heating at 150  $^\circ\text{C}$  for 2 h.

## 2.4. Catalytic tests

These were carried out in a semi-batch recirculation reactor (Fig. 1), where the membrane was sealed in a tubular holder. From the inner side  $\text{H}_2$  was fed at constant pressure (2–3 bar) whereas an oxygen-saturated acidic solution continuously circulated (25 ml/min, 1 bar) on the outer side of the membrane (where Pd was deposited). The circulating solution was 100 ml of 0.03 M  $\text{H}_2\text{SO}_4$  containing 6 ppm NaBr as a promoter.  $\text{H}_2\text{O}_2$  concentration was determined by permanganometric titration.

## 3. Results and discussion

### 3.1. $\alpha$ -Alumina asymmetric membranes (AAM)

A dense Pd film was deposited on such supports by EPD, as stated in the Section 2.

After thermal treatment in inert atmosphere at different temperatures, two kind of surfaces could be obtained: (i) a rough and disordered surface after a thermal treatment in inert gas at 800  $^\circ\text{C}$ , as shown in Fig. 2(a) and (ii) a surface formed of well developed crystallites after a thermal treatment at 500  $^\circ\text{C}$  (Fig. 2(b)). A notable difference in reactivity was observed for these two different surfaces (Fig. 3): large, ordered crystallites on the surface showed a very high ability to produce  $\text{H}_2\text{O}_2$  compared to the disordered, microcrystalline surface. The presence of regular metal surfaces seems therefore to be mandatory to obtain a high rate of reaction in  $\text{H}_2\text{O}_2$  synthesis and a low decomposition rate.

### 3.2. Carbon coated alumina membranes (CAM)

The carbon layer of these membranes possesses a high surface area as shown by  $\text{N}_2$  physisorption measurements, summarized in Table 1, and are micro- to meso-porous. HRTEM analysis shows that the Pd particles deposited are evenly distributed and the dimensions range is between 5 and 10 nm (Fig. 4) for almost all the membranes prepared. Most of them possess 7–8 nm-sized Pd particles. Correlation between catalytic activity and average particle diameter determined by CO chemisorption shows that 8 nm-sized particles are more active than smaller ones. These membranes were highly reproducible and fairly active.

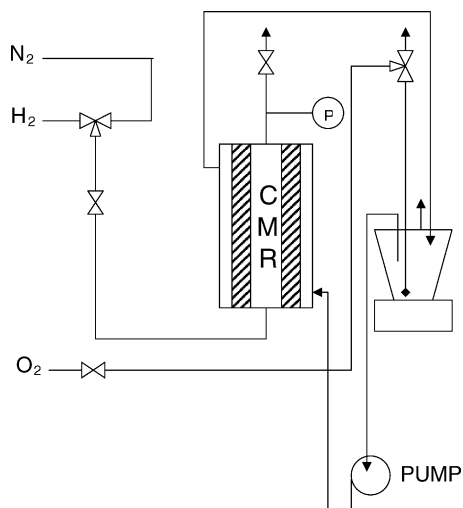


Fig. 1. Scheme of the experimental apparatus used for the catalytic tests.

Table 1  
Surface characterization data on support, CAM and AAM

Membrane	Specific surface area ( $\text{m}^2/\text{g}$ )	Pore size range
Bare $\alpha$ -alumina support	<1	3 $\mu\text{m}$
AAM's	<1	50–100 nm
CAM's	700–800	1–3 nm

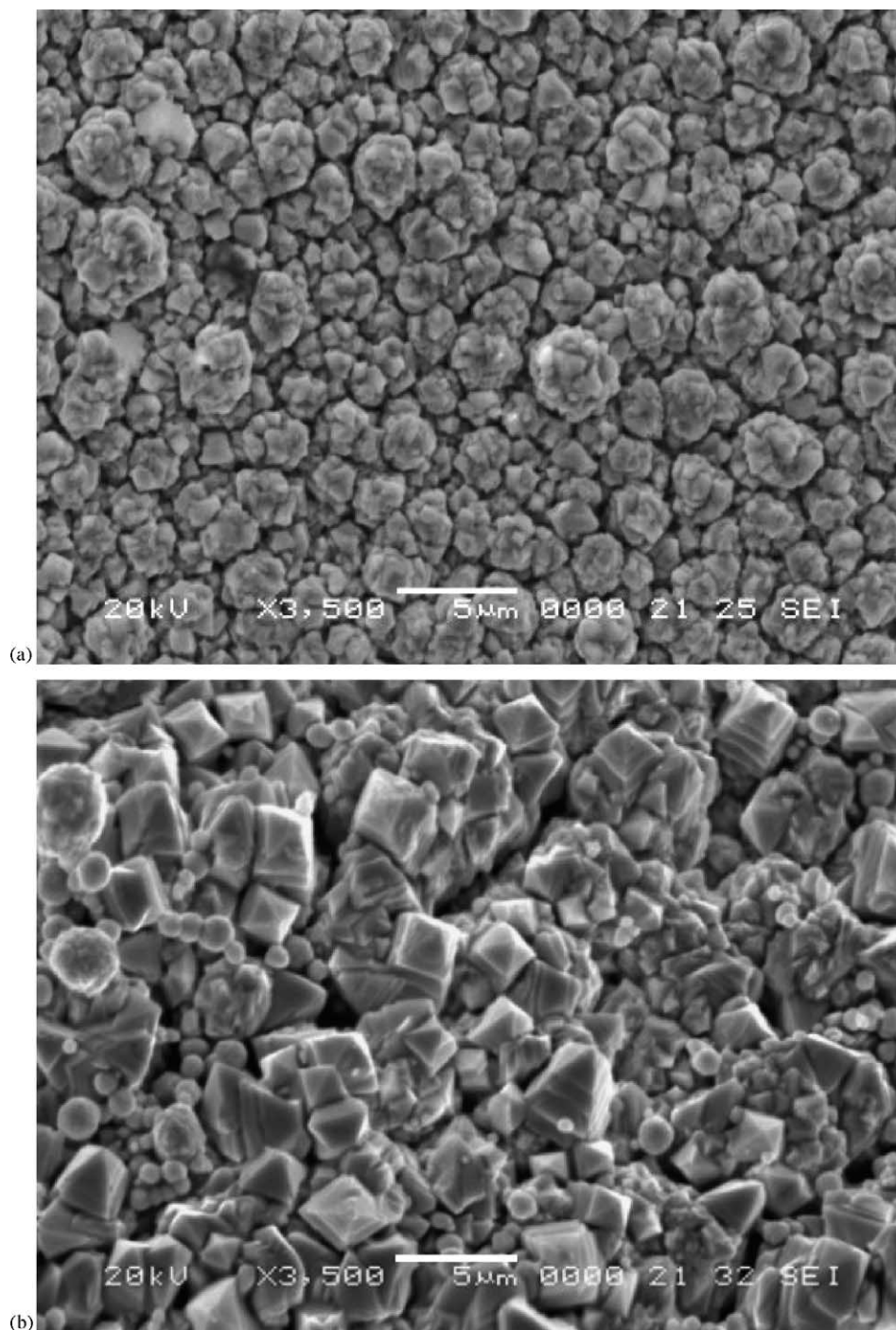


Fig. 2. (a and b) SEM cross-section and surface images of the nearly-dense Pd film on an AAM.

### 3.3. Catalytic activity

The following features are described for CAM's, but similar results were obtained also for AAM's.

An important observation was that a preliminary oxidation treatment is mandatory for the membrane to be catalytically efficient. Non-oxidized membranes show lower catalytic activity than oxidized ones (Fig. 5). Oxidation pre-

treatment was carried out either by soaking the membrane in a concentrated  $\text{H}_2\text{O}_2$  solution (AAM's), or by circulating an oxygen-saturated solution on the membrane (CAM's) which is mounted in the CMR holder and pressurized with  $\text{N}_2$  from the inner side (Fig. 1). Similar results were obtained with both activations.

$\text{H}_2\text{O}_2$  decomposition tests were carried out by circulating a solution containing 2000 ppm  $\text{H}_2\text{O}_2$ . Either pure  $\text{H}_2$  or

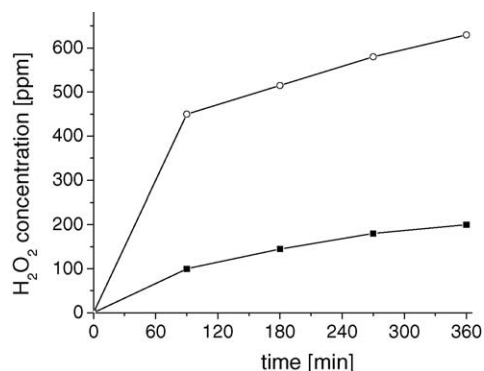


Fig. 3. Comparison between catalytic activity of commonly encountered disordered Pd film (black squares) surface and well-developed Pd crystallites (hollow circles).

pure N<sub>2</sub> were fed inside the membrane at constant pressure in order to evaluate the effect on the decomposition rate. The presence of H<sub>2</sub> improves the ability of the membrane to decompose H<sub>2</sub>O<sub>2</sub> as evidenced in Fig. 6, whereas in the absence of H<sub>2</sub> only a small amount of H<sub>2</sub>O<sub>2</sub> was decomposed. This seems to indicate that the preferential

decomposition pathway was the reduction of H<sub>2</sub>O<sub>2</sub> by H<sub>2</sub> and that an oxygen-saturated acidic solution (from H<sub>2</sub>SO<sub>4</sub>) prevents spontaneous H<sub>2</sub>O<sub>2</sub> disproportionation. Therefore the presence of surface oxygen on Pd seems to be necessary to promote the synthesis of H<sub>2</sub>O<sub>2</sub> and minimize its decomposition.

The catalytic activity of the membranes depends on the reaction temperature, due to the different solubilities of the reactant gases (bottom of Fig. 7): lower temperatures tests (5 °C) showed a higher H<sub>2</sub>O<sub>2</sub> overall production rate with respect to those performed at room temperature (25 °C). In fact, with reference to Fig. 7, it is clear that at 25 °C the decomposition rate is higher than the synthesis rate. On the contrary, if the temperature is reduced to 5 °C, all the kinetics are slowed down, but to a larger extent that of H<sub>2</sub>O<sub>2</sub> decomposition. The final effect is an increase in the overall selectivity towards H<sub>2</sub>O<sub>2</sub>.

On the basis of the results observed with both types of catalytic membranes, we suggest the following possible reaction pathway (see Scheme 1) for the formation of hydrogen peroxide: O<sub>2</sub> chemisorbs on large, non defective (and hence less energetic) Pd particles without dissociation,

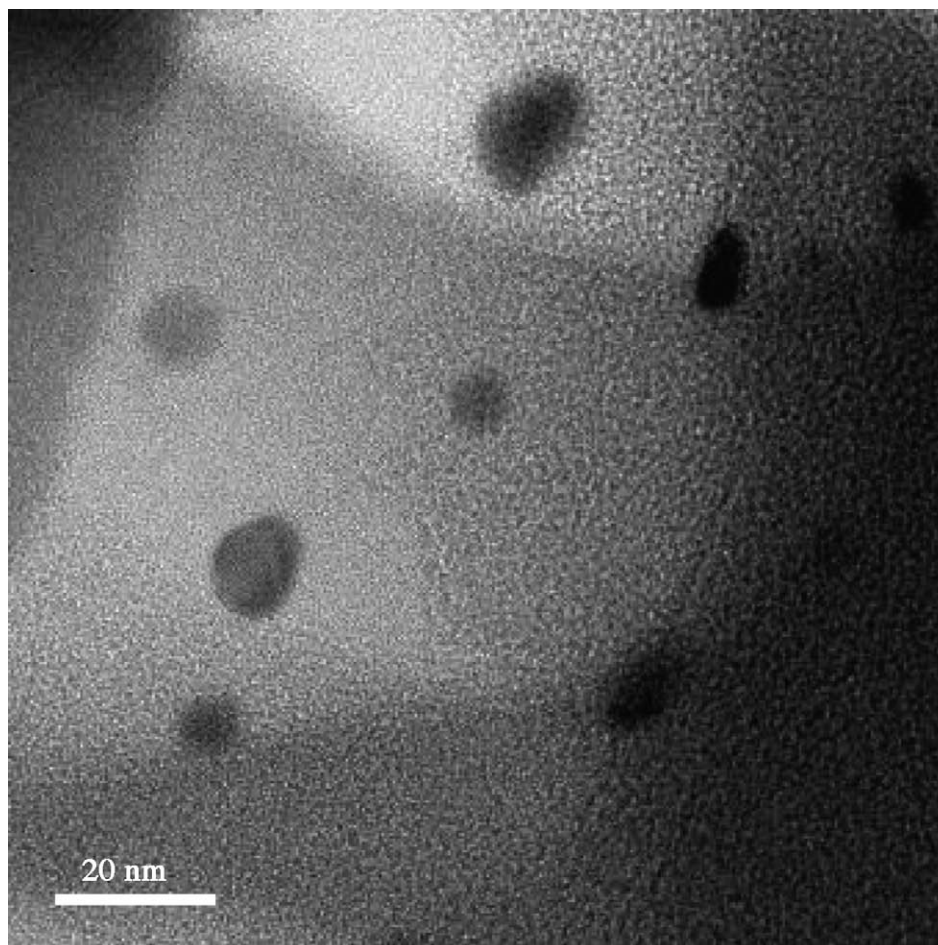


Fig. 4. HRTEM images of Pd particles on a CAM.

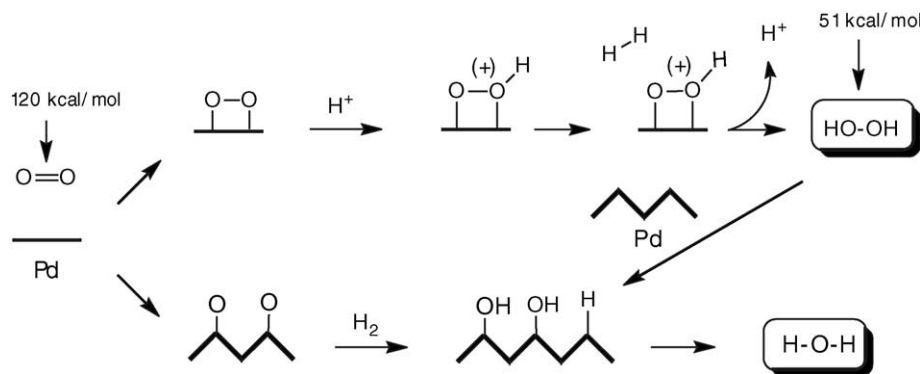
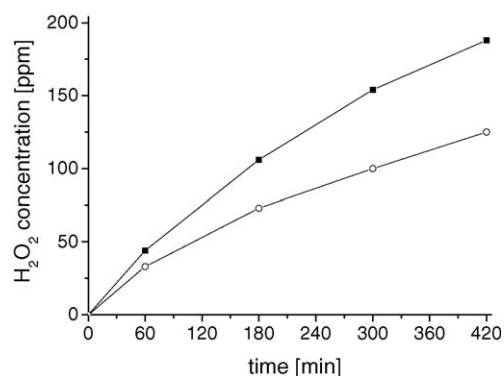
Scheme 1. Probable pathway for the synthesis of  $\text{H}_2\text{O}_2$  on Pd catalysts.

Fig. 5. Effect of the oxidation treatment on catalytic activity for CAM's. Legend – black square: pre-oxidized sample, hollow circle: non-oxidized sample.

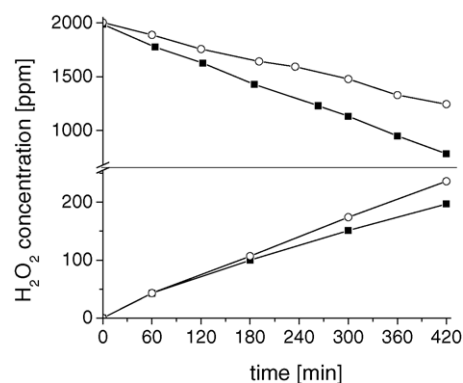
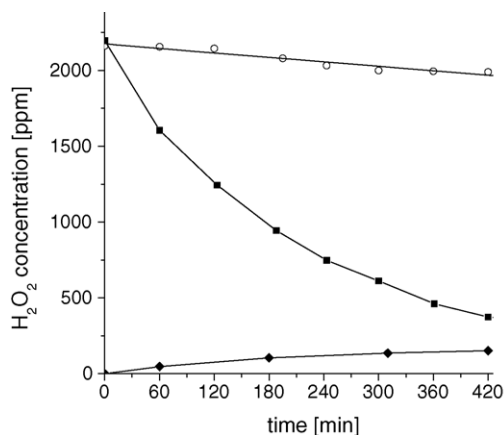


Fig. 7. Catalytic tests at different temperatures (5 and 25 °C) for CAM's. Legend – black square: test at 25 °C, hollow circle: test at 5 °C.

a necessary condition to give the desired  $\text{H}_2\text{O}_2$  product. Then, protonation from external  $\text{H}^+$  takes place, followed by reaction with non-chemisorbed  $\text{H}_2$  which leads to the formation of  $\text{H}_2\text{O}_2$  and restores  $\text{H}^+$ . This is in agreement with the observation that a fully oxidized surface maximizes  $\text{H}_2\text{O}_2$  formation. At the same time, more energetic sites

(defects, edges, corners, etc.) will dissociatively chemisorb  $\text{O}_2$  (or readsorb  $\text{H}_2\text{O}_2$ ). The presence of chemisorbed hydrogen will lead to the formation of water either directly by reaction with oxygen atoms or by reaction with OH fragments coming from  $\text{H}_2\text{O}_2$ . The need for promoters like  $\text{Br}^-$ , which can act as electron scavenger, will inhibit radical-type decomposition pathways.

Fig. 6. Decomposition of  $\text{H}_2\text{O}_2$  in presence and in absence of  $\text{H}_2$ . Legend – black square: decomposition test in the presence of  $\text{H}_2$ , hollow circle: decomposition test in the absence of  $\text{H}_2$ , diamond: synthesis test at 25 °C.

#### 4. Conclusions

Tubular catalytic membranes are able to catalyze  $\text{H}_2\text{O}_2$  synthesis under mild conditions (2–3 bar  $\text{H}_2$ , 5–25 °C) with a fair productivity ( $\sim 2 \text{ mmol H}_2\text{O}_2 \text{ g}_{\text{Pd}}^{-1} \text{ min}^{-1}$ ). Regardless of the type of membrane, catalytic activity depends on: (i) the oxidation state of surface Pd atoms (a pre-oxidation step is needed); (ii) the temperature (temperatures as low as 2–5 °C favor  $\text{H}_2\text{O}_2$  synthesis over decomposition). In addition, the decomposition of  $\text{H}_2\text{O}_2$  on tested catalysts mainly proceeds via its reduction by  $\text{H}_2$ .

Specific features were observed for the two different types of membrane:

CAM's catalytic activity depended strongly on the Pd particle size, whereas well developed crystallites was necessary to improve catalytic activity of AAM's. These

features seem to indicate that a smooth metallic surface was necessary to improve catalytic activity.

### Acknowledgements

Financial support from EU (contract No. G5RD-CT2002-00678) is gratefully acknowledged. The authors are indebted to HITK e.V. and Mast Carbon Ltd. for kindly providing the  $\alpha$ -alumina tubular membranes and the carbon coating. Finally the authors thank Dr. Ing. Roland Dittmeyer and Mr. Karel Svajda from DECHEMA e.V. for useful discussions.

### References

- [1] H.-J. Riedl, G. Pfeleiderer, US Patent No. 2,215,883 (1940).
- [2] H. Henkel, W. Weber (Henkel & Cie), US Patent No. 1,108,752 (1914).
- [3] L.W. Gosser (Du Pont), US Patent 4,681,751 (1987).
- [4] L. Kim, G.W. Schoenthal (Shell Oil), US Patent No.4,007,256 (1977).
- [5] J. Van Weynbergh, J.-P. Schoebrechts, J.-C. Colery (Solvay Interlox), PCT Patent No. WO92/15520 (1992).
- [6] G. Paparatto, R. D'Aloisio, G. De Alberti, R. Buzzoni (Eni), European Patent No. EP 1 160 196 A1 (2001).
- [7] B. Zhou, L.-K. Lee (Hydrocarbon Technologies), US Patent No. 6,168,775 B1 (2001).
- [8] F. Moseley, P.N. Dyer (Air Product), US Patent No. 4,336,240 (1982).
- [9] F. Klemens, K. Gerd, S. Achim, F. Martin, H. Wolfgang, Q. Stefan, M. Klemens (BASF), PCT Patent No. WO98/16463 (1998).
- [10] J.A. McIntyre, S.P. Webb (Dow Chemical), PCT Patent No. WO95/30474 (1995).
- [11] V.R. Choudary, S.D. Sansare, A.G. Gaiwad (Council of Scientific and Industrial Research – India), US Patent No. 6,448,199 B1 (2002).
- [12] (a) V.R. Choudary, A.G. Gaiwad, S.D. Sansare, *Angew. Chem. Int. Ed.* 40 (2001) 1776;  
(b) G. Centi, R. Dittmeyer, S. Perathoner, M. Reif, *Catal. Today* 79–80 (2003) 139.
- [13] L.A.M. Hermans, J.W. Geus, *Stud. Surf. Sci. Catal.* 3 (1979) 113.
- [14] A.J. van Dillen, J.W. Geus, L.A.M. Hermans, J.v.d. Meijden, in: G.C. Bond, et al. (Eds.), *Proceedings of the Sixth International Congress Conference on Catalysis*, London, 1976, p. 677.
- [15] K.P. de Jong, *Stud. Surf. Sci. Catal.* 63 (1991) 19.