

6-2019

Microfluidic Chip for High Efficiency Microinjection of *Caenorhabditis elegans*

Delaney Gray

Alex Hadsell

Jessica Talamantes

Follow this and additional works at: https://scholarcommons.scu.edu/bioe_senior



Part of the [Biomedical Engineering and Bioengineering Commons](#)

Recommended Citation

Gray, Delaney; Hadsell, Alex; and Talamantes, Jessica, "Microfluidic Chip for High Efficiency Microinjection of *Caenorhabditis elegans*" (2019). *Bioengineering Senior Theses*. 87.
https://scholarcommons.scu.edu/bioe_senior/87

This Thesis is brought to you for free and open access by the Engineering Senior Theses at Scholar Commons. It has been accepted for inclusion in Bioengineering Senior Theses by an authorized administrator of Scholar Commons. For more information, please contact rsroggin@scu.edu.

SANTA CLARA UNIVERSITY

Department of Bioengineering

I HEREBY RECOMMEND THAT THE THESIS PREPARED UNDER MY SUPERVISION
BY



Delaney Gray, Alex Hadsell, Jessica Talamantes

ENTITLED

**MICROFLUIDIC CHIP FOR HIGH EFFICIENCY
MICROINJECTION OF CAENORHABDITIS ELEGANS**

BE ACCEPTED IN PARTIAL FULFILLMENT OF THE REQUIREMENTS FOR THE
DEGREE OF

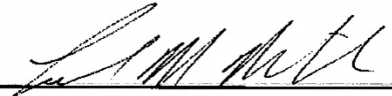
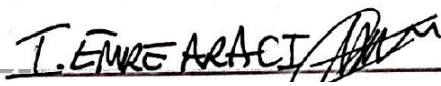
**BACHELOR OF SCIENCE
IN
BIOENGINEERING**

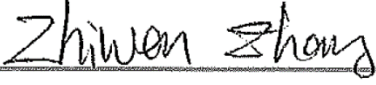
 _____ Advisor: Dr. Leilani Miller – SCU Biology Department	6/6/19 _____ Date
 _____ Advisor: Dr. Emre Araci – SCU Bioengineering Department	6/7/19 _____ Date
 _____ Advisor: Dr. Donald Riccomini – SCU English Department	6/5/2019 _____ Date
 _____ Bioengineering Department Chair	6/7/19 _____ Date

MICROFLUIDIC CHIP FOR HIGH EFFICIENCY MICROINJECTION OF CAENORHABDITIS ELEGANS

By
Delaney Gray, Alex Hadsell, and Jessica Talamantes

SENIOR DESIGN PROJECT REPORT

Submitted to
the Department of Bioengineering

of

SANTA CLARA UNIVERSITY

in Partial Fulfillment of the Requirements for the degree of Bachelor of Science in
Bioengineering

Santa Clara, California

June 2019

Abstract

The terrestrial nematode, *Caenorhabditis elegans*, is an invaluable model organism for the study of molecular and cellular processes due to their small size, rapid generation time, easy cultivation, and invariant cell number. Additionally, 40% of genes known to be associated with human disease have clear orthologs in the *C. elegans* genome. In *C. elegans* genetics research, microinjection of genetic material into the worms is critical. Although an established technique, manual microinjection is tedious, low-throughput, and requires an expert researcher. This thesis details a novel microfluidic device designed to perform high-throughput microinjection. This two-layer, PDMS-based chip integrates microfluidic elements to control worm sorting, reduction of immobilization time and stress, and novel on-chip microinjection using only a positive pressure source. Our project aim is to increase microinjection efficiency, consistency, and accessibility to researchers of all experience levels in order to advance genetics research and genetic engineering technology in *C. elegans*. Preliminary results are promising, as our on-chip microinjection device has been able to successfully inject dye into *C. elegans* animals.

Keywords: C. elegans, Microinjection, Microfluidics, On-chip Microinjection, Genetics

Acknowledgements

We would like to thank Dr. Emre Araci for his constant support, invaluable advice, infectious enthusiasm and for always encouraging us try something new.

We would also like to thank Dr. Leilani Miller for inspiring our project as well as providing the supplies and guidance necessary to help us succeed.

A special thanks to Dr. Don Riccomini for serving as our Honors Thesis reader. We are so grateful for all the time and energy that he has invested into our thesis and project presentation.

We would also like to thank Daryn Baker and Dan Levy for supporting our work in the Biology and Bioengineering departments. They never found any request too frivolous or any question too simple.

We would like to recognize Santa Clara University's Engineering Department for providing the funding, incredible faculty and staff, and high-quality research labs that made this project possible.

Finally, we would like to thank our friends and family who have supported us throughout our academic careers. This would not have been possible without you.

Table of Contents

Signature page.....	i
Title page	ii
Abstract.....	iii
Acknowledgements.....	iv
Table of Contents.....	v
List of Figures.....	x
List of Tables	xii
List of Abbreviations	xiii
Chapter 1: Introduction	1
1.1. Motivation	1
1.2. <i>C. elegans</i> background and basics.....	1
1.3. Creation of transgenic <i>C. elegans</i> animals using microinjection	2
1.4. Limitations of manual microinjection	2
1.5. Critical elements for a successful microinjection	3
1.6. A primer on microfluidic technology.....	5
1.6.1. Fluid properties.....	5
1.6.2. Material properties.....	5
1.6.3. Application of microfluidics to <i>C. elegans</i> research	5
1.7. Existing microfluidic microinjection technology.....	6
1.7.1. Microfluidic alignment of <i>C. elegans</i>	6
1.7.2. Microfluidic immobilization of <i>C. elegans</i>	7
1.7.3. Microfluidic microinjection of <i>C. elegans</i>	8
1.8. Critique of current technologies	10
1.9. Project goal.....	11
1.10. Back-up plan	11
1.11. Project significance	12
Chapter 2: Microfluidic Chip Design and Fabrication	13
2.1. Introduction	13
2.2. Key constraints.....	13
2.2.1. Microfluidic lab vacuum system control.....	13

2.2.2. Flow channel width versus worm mobility	13
2.2.3. Microinjector membrane thickness	14
2.3. Detailed design description	14
2.3.1. Chip input	15
2.3.2. Micropillar array.....	15
2.3.3. Immobilization channel	16
2.3.4. Microinjection region	16
2.3.5. Offloading area	17
2.4. Expected results.....	18
2.5. Materials and methods	18
2.5.1. Photolithography masks	19
2.5.2. Photolithography procedure	19
2.5.2.1. Control layer	19
2.5.2.2. Flow layer	19
2.5.3. Soft lithography procedure	20
2.5.3.1. Control layer	20
2.5.3.2. Flow layer	20
2.5.4. Plasma bonding treatment	21
2.5.5. Microfluidic multiplexer	21
2.6. Results and discussion.....	21
2.6.1. Layer alignment.....	21
2.6.2. Sensitive features.....	22
2.6.3. Channel collapse.....	22
Chapter 3: <i>C. elegans</i> preparation and loading	24
3.1. Introduction	24
3.2. Key constraints	24
3.2.1. Constraint: Synchronized <i>C. elegans</i> population	24
3.2.2. Constraint: Maintaining <i>C. elegans</i> inside the chip	26
3.2.3. Constraint: Loading worms at an acceptable concentration.....	26
3.3. Detailed design description	27
3.3.1. <i>C. elegans</i> maintenance	27
3.3.2. <i>C. elegans</i> age synchronization	27

3.3.3. Loading <i>C. elegans</i> into chip.....	28
3.4. Results and discussion.....	28
Chapter 4: <i>C. elegans</i> Immobilization.....	30
4.1. Introduction	30
4.2. Key constraints	30
4.2.1. Cannot use negative pressure system controls	30
4.2.2. Only using positive pressure system controls	30
4.3. Proposed analysis and expected results.....	31
4.3.1. Immobilized worm motion measurements	31
4.3.2. Anticipated results	31
4.4. Back-up plan	31
4.5. Materials and methods	31
4.6. Results	32
4.7. Discussion	33
Chapter 5: Microfluidic Microinjection of <i>C. elegans</i>	34
5.1. Introduction	34
5.2. Key constraints.....	35
5.3. Detailed design description	35
5.3.1. Needle preparation and insertion into membrane.....	35
5.3.1.1. Pulling microneedles from glass capillaries	35
5.3.1.2. Breaking sealed needle tip	36
5.3.1.3. Cutting needle tip fragments for on-chip injection	37
5.3.1.4. Embedding needle fragments into membrane of microinjector chamber	39
5.3.1.5. Needle tip flow testing	40
5.4. Results	41
5.5. Discussion	42
Chapter 6: Chip Validation – COMSOL Simulation of Microinjector Region.....	44
6.1. Introduction	44
6.2. Key constraints.....	44
6.3. Detailed design description	44
6.3.1. Microinjection region for membrane deflection simulation.....	44
6.3.2. Embedded needle for needle movement simulation.....	46

6.4. Simulation methods.....	47
6.4.1. Membrane deflection simulation.....	47
6.4.2. Needle movement simulation.....	47
6.5. Results and discussion.....	47
6.5.1. Membrane deflection.....	47
6.5.2. Needle movement.....	49
6.5.3. Discrepancies between simulation and observation.....	49
Chapter 7: Summary and Conclusion.....	50
7.1. Restatement of project objective.....	50
7.2. Project accomplishments.....	50
7.2.1. 100% microfluidic device.....	50
7.2.2. Design novelty.....	50
7.3. Future work.....	51
7.3.1. Complete characterization of novel, on-chip microinjector.....	51
7.3.2. Injection of genetic construct.....	51
7.3.3. Post-injection analysis.....	52
7.4. Engineering standards.....	52
7.4.1. Health and safety.....	52
7.4.2. Manufacturability.....	54
7.4.3. Usability.....	55
7.4.4. Science, technology, and society.....	56
7.4.5. Economic.....	56
7.4.6. Environmental impact.....	57
7.4.7. Civic engagement.....	57
7.4.8. Sustainability.....	57
7.5. Team and management.....	58
7.6. Budget.....	58
7.7. Project timeline.....	59
Bibliography.....	60
Appendices.....	A1
A. Manual microinjection procedure.....	A1
B. Ordering and maintaining <i>C. elegans</i> N2 strain.....	A2

C. Preparation of Nematode Growth Medium (NGM) agar plates	A2
D. Magnetic density-based sorting of <i>C. elegans</i>	A4
E. Ethical Analysis of Microfluidic Chip for Microinjection of <i>C. Elegans</i>	A10

List of Figures

1. Injection of genetic material into distal tip of <i>C. elegans</i> gonad	4
2. Schematic representation of a microfluidic chip that uses a glass actuator to rotate a single worm	6
3. Microfluidic immobilization of worm head and tail using suction.....	7
4. Microinjection of <i>C. elegans</i> animals within a microfluidic chip	9
5. Example AutoCAD design of full microfluidic microinjection chip.....	14
6. AutoCAD design of micropillar array within microfluidic microinjection chip	15
7. AutoCAD design of immobilization region of microfluidic microinjection chip	16
8. AutoCAD design of microinjector region of microfluidic microinjection chip.	17
9. AutoCAD design of offloading region of microfluidic microinjection chip	17
10. Overview of photolithography and soft lithography procedures.	18
11. Flow and control layer microinjector region alignment	21
12. Test-filling flow layer of microinjector region with red dye	22
13. Image depicting extreme collapse of microinjector control valve.....	23
14. Reversibility of collapsed microinjection control valves under extreme pressure	23
15. Life cycle of <i>C. elegans</i>	25
16. <i>C. elegans</i> inside of microfluidic chip tubing.....	27
17. AutoCAD schematic showing flow and control layer design in immobilization region.....	32
18. Immobilization of <i>C. elegans</i> worms utilizing actuated control valve	33
19. Concept design for novel, on-chip microinjection chamber.....	34
20. Brown Micropipette Puller pulling two glass microinjection needles.....	36
21. Breaking of glass microinjection tip to allow fluid flow	37
22. Cutting needle tip fragments used for on-chip microinjection	38
23. Embedding needle tip fragment into thin membrane of microinjector region.....	40
24. Ejection of red food dye through embedded microneedle tip.....	41
25. Injection of red dye into <i>C. elegans</i> using novel on-chip microinjector.....	42
26. COMSOL model of microfluidic microinjection region based on a glass model	45
27. COMSOL model of microinjection region chamber	45
28. COMSOL model showing effect of control valve on embedded needle movement	46
29. COMSOL model depicting the membrane stress that results from applying a boundary load to microinjection chamber	48

30. Graph comparing applied pressure to thin membrane deflection based on COMSOL simulation.....	48
31. Schematic of manual microinjection procedure	A1
32. Live, unanesthetized worms levitating in LeviCell instrument	A8
33. Live, anesthetized worms levitating in LeviCell instrument	A9

List of Tables

1. Team member specialties and contact information	58
2. Project budget breakdown.....	58
3. Project timeline	59

List of Abbreviations

C. elegans - *Caenorhabditis elegans*

Cas 9 – CRISPR associated protein 9

CNS - Center for Nanostructures (located at SCU)

CRISPR - Clustered Regularly Interspaced Short Palindromic Repeats

L1 - 1st larval stage in *C. elegans* development

L4 - 4th larval stage in *C. elegans* development

N2 - wild-type worm strain

NGM agar plates - Nematode growth medium agar plates

PDMS - Polydimethylsiloxane

RPM – rotations per minute

SCU - Santa Clara University

SPR - Type of positive photoresist used in microfabrication

SU-8 2050 - Type of negative photoresist in microfabrication

TMCS - Trimethylchlorosilane

WT - wild type

Chapter 1: Introduction

1.1. Motivation

The terrestrial nematode, *Caenorhabditis elegans*, is an invaluable model organism for the study of molecular and cellular processes due to its small size, rapid generation time, easy cultivation, sequenced genome, and invariant cell number. Additionally, 40% of genes known to be associated with human disease have clear orthologs in the *C. elegans* genome. In *C. elegans* genetics research, microinjection of genetic material into the worms is critical to the creation of transgenic animals. Although an established technique, manual microinjection is tedious, low-throughput and requires an expert, making it a major rate limiting step in *C. elegans* genetic research. Our project goal was to utilize microfluidic technology to increase microinjection efficiency, consistency, and accessibility to researchers of all experience levels in order to advance genetics research and genetic engineering technology in *C. elegans*.

1.2. *C. elegans* background and basics

C. elegans is a type of terrestrial, transparent nematode that grows to be about 1 mm in length and 30-45 μ m in width. While generally found in temperate soil environments, these worms can be easily cultivated and studied in the lab.

C. elegans has served as an invaluable genetics model organism since the 1970's due to the high degree of similarity found between its cellular and molecular processes (i.e. morphogenesis, biochemical signaling pathways, protein coding genes) and those found in humans. The *C. elegans* genome contains orthologs for 60-80% of human genes, 40% of which are related to human disease states such as cancer¹. *C. elegans* has also served as an excellent medium for optimizing

¹ Corsi et al. "A transparent window into biology: a primer on *Caenorhabditis elegans*." *Genetics*, (2015).

genetic engineering technologies (i.e. CRISPR/Cas 9) as genetics research has been conducted on them for decades and knowledge of their genome is well established.

In addition to its value as a genetics model organism, *C. elegans* possess a number of favorable properties making it an excellent research subject. Some of these characteristics include:

- Optical transparency
- Small size
- Simple anatomy with fully mapped cell lineages
- Easy cultivation (grown in petri dishes)
- Quick generation time (3 days at 23°C)
- Hermaphroditic (self-fertilization useful in genetics research)
- Completely sequenced genome

1.3. Creation of transgenic *C. elegans* animals using microinjection

In many *C. elegans* genetics labs, researchers attempt to alter, disrupt, or replace genes in order to study their function. One way to alter the *C. elegans* genome for research purposes is to manually microinject genetic material into a worm's newly forming oocytes. The genetic material can range from simple plasmids to genetic engineering constructs and proteins such as CRISPR/Cas 9. For example, in Dr. Leilani Miller's lab at Santa Clara University (SCU), certain sequences of the *C. elegans* genome are edited by injecting plasmids coding for a guided CRISPR/Cas 9 construct. This CRISPR/Cas 9 complex cuts and edits certain sequences in the worm genome to disrupt the phosphorylation sites of a particular transcription factor. This allows her to study the role that phosphorylation of that particular protein plays in a biochemical signaling pathway.

1.4. Limitations of manual microinjection

To emphasize the tedious nature of manual microinjection, we have outlined the key steps of this process below:

- Pull a very small glass capillary (external diameter = 1 mm, internal diameter = 0.58 mm) into an even smaller glass microinjection needle (tip diameter ~ 1 μ m)
- Load the needle with injection mix
- Transfer worm to drop of injection oil on a desiccated agarose pad
- Manually rotate wriggling 1mm x 40 μ m worm into the correct orientation for injection
- Manually press the worm against the agarose injection pad so that it will adhere and hold still (without popping the worm)
- Manually puncture the worm's gonad and flood its distal tip with injection mix
- Remove the worm before it desiccates on the injection pad and proceed with recovery process

Although this is an abbreviated list of the microinjection procedure, we hope that it is now apparent how delicate and labor intensive this process can be and why many researchers spend years mastering this technique. To see a visual depiction of the manual microinjection process, see Appendix A.

1.5. Critical elements for a successful microinjection

To properly inject genetic material into a worm, a researcher must insert the needle into the worm at the correct angle, on the correct side of their body, and apply the perfect amount of force to barely puncture the cuticle of the worm and flood its gonad with injection mixture. With this delicate procedure, it is easy for a researcher to accidentally kill the animal by pushing too hard, inserting the needle at the wrong angle, or by using a blunt needle

To successfully create transformants, the injected worms must be healthy young adult hermaphrodites with plenty of developing oocytes in their gonad². An

² Evans et al. "Transformation and microinjection." *WormBook*, (2006).

optimal injection will puncture and flood the distal tip of one or both of the worm's gonads with the desired genetic construct (Figure 1)³.

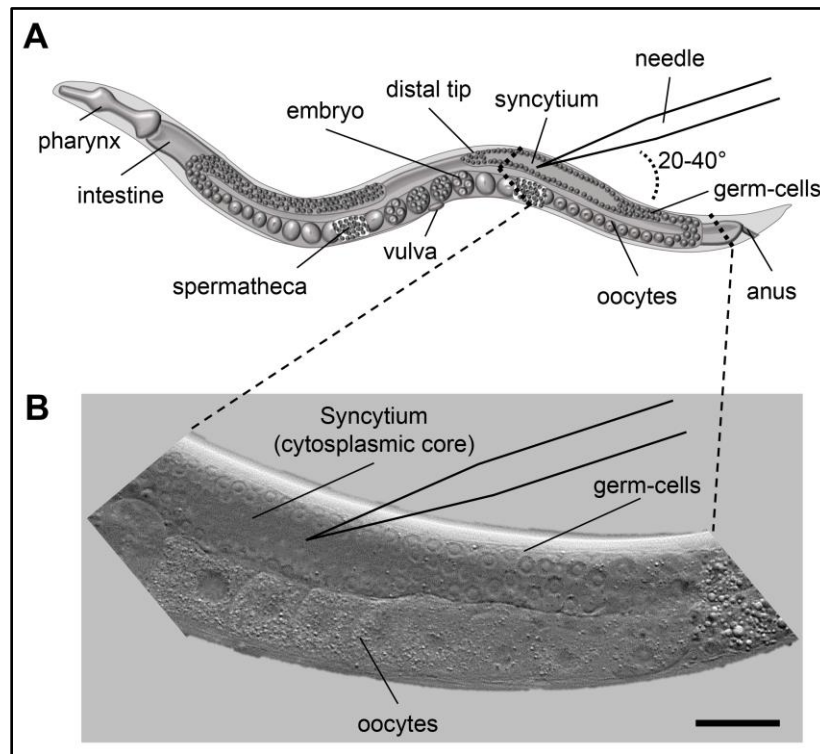

Figure 1. Injection of genetic material into distal tip of *C. elegans* gonad. (A) Schematic showing proper microneedle angle and insertion point into worm gonad for a successful microinjection of genetic material. (B) Close-up of worm gonad showing insertion of microneedle tip into the syncytium of the distal tip of the gonadal arm. Image adapted from Rieckher et al (2017)³.

Successful transformation of germ-line cells is dependent on injection of genetic material into the cytoplasmic core of the syncytium located at the distal tip of the hermaphrodite's gonad⁴ (Figure 1B). This allows the injected genetic material to become incorporated into the new eggs as their newly forming plasma membranes encapsulate both the oocyte nuclei and the cytoplasm containing the injected genetic material. Incorporation of genetic material into the newly formed oocytes produces successful genetic transformants.

³ Rieckher et al. "Generation of *C. elegans* Transgenic Animals by DNA Microinjection." *Bio-protocol* (2017).

⁴ Evans et al. "Transformation and microinjection." *WormBook*, (2006).

Given the detailed nature of the microinjection procedure coupled with the microscopic size of the target injection site, microinjection is a major rate limiting step in *C. elegans* genetics labs around the world.

1.6. A primer on microfluidic technology

Microfluidic technology allows the user to interact with various systems at a micron scale. Microfluidic chips have four main advantages: miniaturization, increased throughput, low-cost, and potential for automation. Channel dimensions are typically <100 μm , providing working volumes within the nanoliter range—well within the dimensions of *C. elegans*.

1.6.1. Fluid properties

Using an array of channels and valves, users can direct the way that fluid flows through microfluidic chips. The primary advantage of working with fluids on the micron scale is that the fluids experience laminar flow, this means that its fluid dynamics are more easily controlled and understood. Additionally, at this scale, researchers are able to use reduced reagent volumes which yields a lower overall cost.

1.6.2. Material properties

Microfluidic chips are primarily made of polydimethylsiloxane (PDMS), an optically clear rubber. Some of the advantages of utilizing PDMS are its flexibility (Young's modulus can be modified by altering the mixture of crosslinker to prepolymer), optical transparency, gas permeability, biocompatibility, and relatively low cost.

1.6.3. Application of microfluidics to *C. elegans* research

Made from PDMS, microfluidic devices are transparent, permeable to gas, non-toxic, and inert; therefore, they are appropriate for biological research. Microfluidic devices maintain controlled flows and allow for easy

handling and manipulation of *C. elegans* animals⁵, making some techniques more accessible and previously impossible ones possible.

1.7. Existing microfluidic microinjection technology

Before embarking on our design project, we isolated three critical components for successful *C. elegans* microinjection: alignment, immobilization, and lastly, microinjection. We conducted a literature review of current microfluidic technologies that address these steps and their application in *C. elegans* research.

1.7.1. Microfluidic alignment of *C. elegans*

In 2016, researchers from York University and Mount Sinai Hospital in Canada created a device for orientation and multidirectional imaging of *C. elegans*. Ultimately, they sought to provide lateral and longitudinal control. In order to achieve this, they incorporated electrotaxis technology into their chip with a rotatable glass capillary that controlled radial alignment⁶. As shown in Figure 2, the worm first experiences the electric field that orients it head-to-tail. Using a direct current, they oriented *C. elegans* locomotion towards the cathode. Then, using fluid flow, a single *C. elegans* animal enters the imaging channel where suction immobilizes the worm from above and the capillary attaches to its head⁷.



Figure 2. Schematic representation of a microfluidic chip that uses a glass actuator to rotate a single worm⁷.

⁵ San-Miguel et al. "Microfluidics as a Tool for *C. elegans* Research." *WormBook*, (2013).

⁶ Ardeshiri et al. "A Hybrid Microfluidic Device for On-demand Orientation and Multidirectional Imaging of *C. elegans* Organs and Neurons." *Biomicrofluidics*, (2016).

⁷ Ardeshiri et al. "A Hybrid Microfluidic Device for On-demand Orientation and Multidirectional Imaging of *C. elegans* Organs and Neurons." *Biomicrofluidics*, (2016).

This novel control technique allows for multidirectional manipulation of *C. elegans* animals. While the research with this microfluidic device focuses on imaging of organs and neurons, the control method demonstrates great potential for aligning and directing microinjector needles into the gonad of a worm.

1.7.2. Microfluidic immobilization of *C. elegans*

There are multiple existing microfluidic technologies that can effectively immobilize *C. elegans*. As seen in the microfluidic chip from Figure 2, one method for immobilization is suction. In that chip, once the worm was in the correct region, suction across the top of the channel would keep the worm in place. Researchers from Wuhan National Laboratory used a slightly different method for immobilization that also utilizes suction. However, this method, depicted in Figure 3, makes use of a supplementary suction in an open chamber⁸.

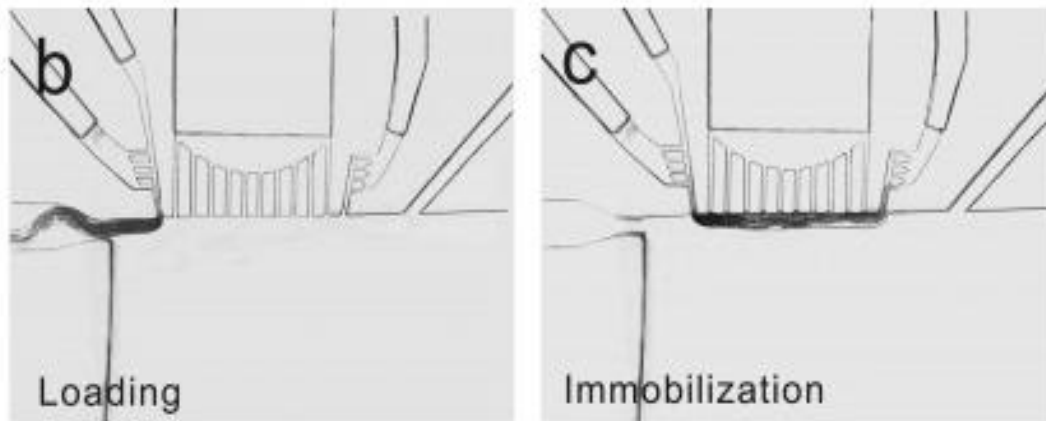

Figure 3. Microfluidic immobilization of worm head and tail using suction. (B) Worm is loaded into immobilization region as its head is suctioned into the first inlet. (C) The worm is immobilized when the flailing tail is caught in the second suction chamber. The suction applied to the worm's head and tail pulls it taut for injection. Image adapted from [8].

⁸ Zhao et al. "Microfluidic Chip-Based *C. elegans* Microinjection System for Investigating Cell-Cell Communication In Vivo." *Biosensors and Bioinformatics*, (2013).

As the worm reaches the end of the flow channel, its end is caught by the supplementary suction in Figure 3b. Then, after the worm is pushed out of the flow channel into the open chamber, the body of the worm is immobilized by the main suction and the other end is caught by the second supplementary suction as seen in Figure 3c. This suction method effectively immobilizes the worm for an external microinjection system to inject the worm.

1.7.3. Microfluidic microinjection of *C. elegans*

Also, in 2016, three researchers from the Department of Mechanical Engineering at McGill University in Canada developed a microfluidic chip that could perform high-speed, automated microinjection of *C. elegans*. This novel device used pneumatic valves to control loading, immobilization, and injection. Figure 4 below shows the microinjection region of the chip—laminar fluid flow transports a single worm across the injection channel, a pneumatic valve pins the worm in place, a needle enters through the injection channel, the needle injects the worm, and then the immobilization valve is released, allowing fluid flow to transport the worm out of the microinjection region.

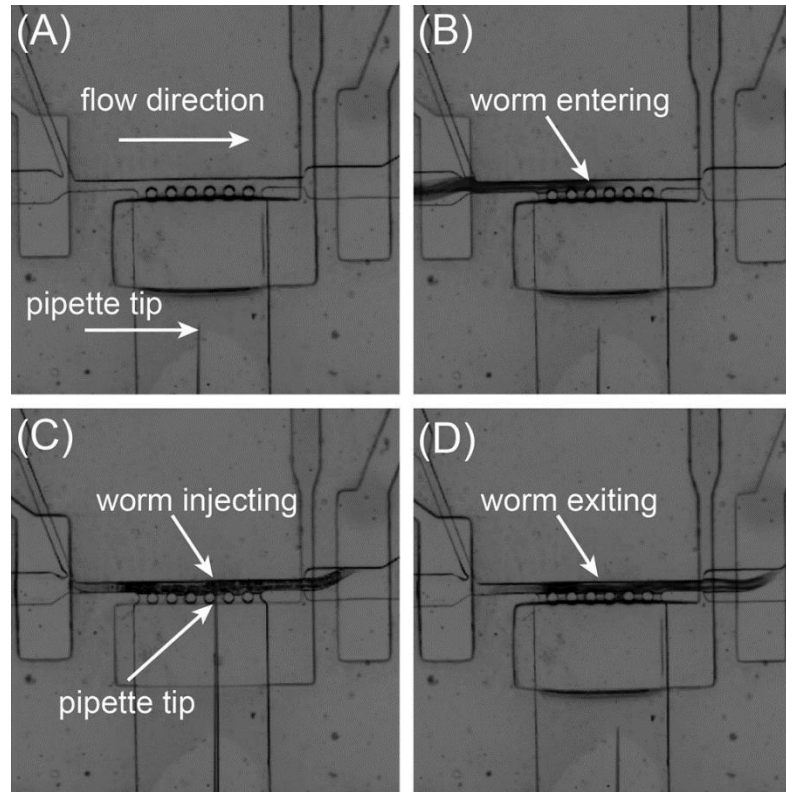

Figure 4. Microinjection of *C. elegans* animals within a microfluidic chip. (A) Worm brought into microinjection chamber utilized positive pressure flow through the flow channel. (B) Worm reaches microinjection region and is immobilized against PDMS teeth using a control valve located on top of the animal. (C) Microinjection needle (labelled as “pipette tip”) brought into microinjection chamber alongside worm. External micromanipulator controls needle tip, targets gonad, and injects worm with desired genetic construct. (D) Once injected, worm is released from the immobilizing control valve and moved forward due to positive pressure from fluid flow.

In a proof of concept experiment, researchers injected 200 *C. elegans* animals, obtaining an average injection rate of 6.6 worms per minute. They obtained a pre-sorting success rate of 77.5% (successfully injected worms compared to total number of injected worms). A successful injection was obtained if they loaded a single worm into the injection chamber and then witnessed the worm body expand with the injection itself⁹. Additionally, they found no statistical difference in lifespan between a control population and the injected worm population. However,

⁹ Song et al. “A Microfluidic Device for Automated, High-Speed Microinjection of *Caenorhabditis elegans*.” *Biomicrofluidics*, (2016)

this device lacked any type of worm orientation and they did not inject genetic material to test for a successful transformation rate.

1.8. Critique of current technologies

In evaluating the state of current microfluidic technology and its applications in manipulating and injecting *C. elegans*, we identified three critical design elements we could address with our device: (1) orientation, (2) immobilization, and (3) microinjection.

The first design element we identified was *orientation* of the worms for microinjection. However, we decided not to pursue this area of design development for two reasons: (1) many well-developed, microfluidic orientation elements already exist and could be easily integrated into any *C. elegans* microfluidic chip, and (2) we intend to create a chip whose high-throughput nature could overcome the barrier of only obtaining a successful injection 33.33% of the time (the gonad comprises ~33% of the worm's body cross-section so even without orientation, the worm would be in the correct orientation $\frac{1}{3}$ of the time).

The second design element we identified was worm *immobilization*. We found that most microinjection chips utilize immobilization methods that place the worms under prolonged and extreme stress. Applying continued stress to the worms increases the probability that they die during injection, decreasing transformation efficiency. Similarly, complex immobilization strategies decrease the throughput of these chips, further decreasing injection efficiency. Therefore, we wanted to design an immobilization element that would reduce the amount of time the worm was subjected to immobilization stress.

The third design element that we identified was *microinjection* itself. The majority of microinjector chips utilized external microinjector elements. That is, they used a microfluidic chip in conjunction with standard microinjector equipment like an inverted microscope, micromanipulator, and injection regulator. While these systems were efficient and consistent in their injections, we believed that they missed the point of microfluidic technology. Microfluidic

technology revolutionizes standard laboratory experiments via miniaturization, integration, automation, and its high-throughput nature. Shrinking down the scale can vastly increase the experiment rate and decrease costs. We believe that previous research missed the mark by simply integrating a microfluidic chip with a standard microinjection set-up. Instead, the goal should be to create a microfluidic device that can conduct orientation, immobilization, and microinjection all on-chip without any external (and expensive) instruments.

1.9. Project goal

With our objective to design improved immobilization and microinjection elements identified, we formulated our project objective:

Design a microfluidic device to conduct on-chip immobilization and microinjection of *C. elegans* without the aid of any external elements. Our chip will increase microinjection efficiency, consistency, and accessibility to researchers of all experience levels to advance genetics research and genetic engineering technology in *C. elegans*.

1.10. Back-up plan

In the event that we were unable to complete our project by the end of the year, we developed a number of back-up plans.

- (1) If we were unable to produce and test a chip that could inject worms, we would at least create a novel design for an on-chip microinjector that could be easily integrated with existing immobilization and orientation elements from other devices.
- (2) If we were unable to complete back-up plan (1), we would at least attempt microinjection using the external microinjection elements that we possessed in Dr. Leilani Miller's *C. elegans* lab at SCU.

1.11. Project significance

In the rapidly expanding field of genetics and genetic engineering research, the manual microinjection process presents a significant rate limiting step. Compared to manual microinjection, a high-throughput, self-contained microfluidic chip could increase the rate of successful *C. elegans* microinjections, increase the number of researchers able to conduct injections, and reduce the cost of injections (fewer startup costs for inverted microscopes, micromanipulators, etc). This technology has the potential to dramatically empower *C. elegans* laboratories around the world to conduct human-relevant genetics research and optimization of genetic engineering technologies.

Chapter 2: Microfluidic Chip Design and Fabrication

2.1. Introduction

The goal of the microfluidic chip is to assist in the microinjection process by immobilizing and orienting worms prior to microinjection. The chip accomplishes this goal using a variety of regions and microfluidic valves.

2.2. Key constraints

Constraints were introduced in two forms: those from the utilized lab spaces, and those imposed by the microfluidic chip itself. Two main lab spaces were used, the Center for Nanostructures (CNS) and Dr. Emre Araci's microfluidics lab at SCU. Regarding the CNS, the primary constraint was a 2:1 resolution ratio of feature height to feature width. The height of the primary flow layer needed to be 40 μm to allow for the worms, so features could not be less than 20 μm wide.

2.2.1. Microfluidic lab vacuum system control

The main constraint of the microfluidic lab was the lack of controllable vacuum system. Many chips that were investigated required the use of a vacuum system to immobilize worms prior to injection. Therefore, it was not possible to use these designs to achieve the immobilization objective.

Similarly, many chip designs utilized a vacuum system to alter the pressure of the channels the worms flow through. In creating negative pressure on one side of the worm, the worms would be sucked into smaller channel widths than their body dimensions normally allow without causing blockages in the chip.

2.2.2. Flow channel width versus worm mobility

Flow channel width versus worm mobility needed to be optimized. Narrow channels would need to afford very little mobility, ensuring that the worms are held in place properly for injection. However, if the

channels became too narrow, without the assistance of a vacuum system, the worms may get stuck in the chip.

2.2.3. Microinjector membrane thickness

The microinjector membrane is optimized to give acceptable levels of deflection when under pressure while retaining its ability to grip an embedded needle. Current designs afford little membrane deflection in favor of holding the needle in the membrane. Making the membrane too thick decreases membrane deflection (See Chapter 6) but increases grip strength on the needle. Decreasing membrane thickness allows for more deflection but less grip of the needle, potentially allowing the needle to fall out during injections.

2.3. Detailed design description

The microfluidic chip has two layers: a control layer and a flow layer. Worms occupy the flow layer, and the control layer determines how fluid flows through the chip.

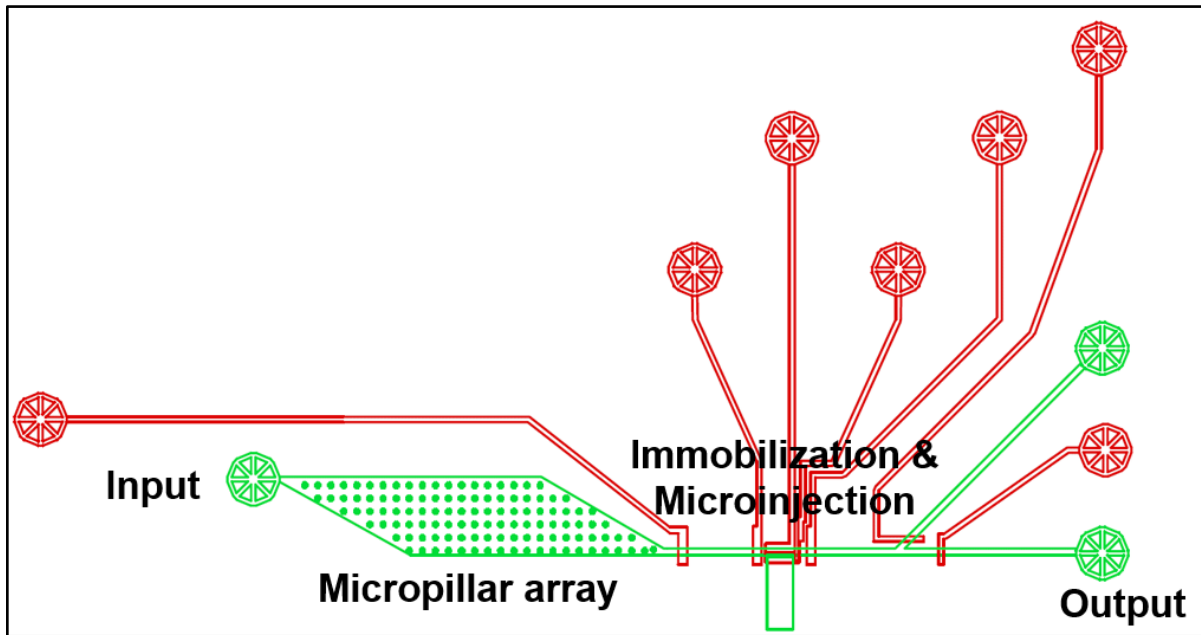

Figure 5. Example AutoCAD design of full microfluidic microinjection chip. Green regions are the flow layer of the chip. Red regions are control valves in the control layer of the chip

The chip can be broken down into four main regions: the input, the micropillar array, the immobilization and injection region, and the outputs.

2.3.1. Chip input

Worms are loaded into the chip at the input by drawing them into a small plastic tube (200 μm diameter). This tube is then connected to the output of a microfluidic cryo tube. The pressure applied to the tube is controlled either manually or by using an external pressure source. Input pressure determines the flow rate through the chip.

2.3.2. Micropillar array

The next region is the micropillar array. The array is designed to separate clumps of worms, as well as filter out any debris that may have been generated by the worms or transferred from the worm plates.



Figure 6. AutoCAD design of micropillar array within microfluidic microinjection chip. Micropillars are utilized to (1) redistribute entering worms and prevent animal clustering, and (2) filter debris to prevent clogging of upcoming narrow flow channels.

Worms enter the micropillar array in the upper left and exit through the lower right. Pillars are 100 μm by 100 μm . The design for the micropillar array is loosely based off an existing design by Song et al. (2016), though all dimensions were approximated, as we were unable to find exact micropillar arrays specified in the source papers¹⁰. The entrance to the micropillar array is 120 μm wide, whereas the exit is either 100 μm wide.

¹⁰ Song et al. "A Microfluidic Device for Automated, High-Speed Microinjection of *Caenorhabditis elegans*." *Biomicrofluidics*, (2016)

We optimized this width so that worms will only load into the primary flow channel one at a time, making orienting and injecting the worms later in the chip easier.

2.3.3. Immobilization channel

The third region of the chip is the immobilization section.

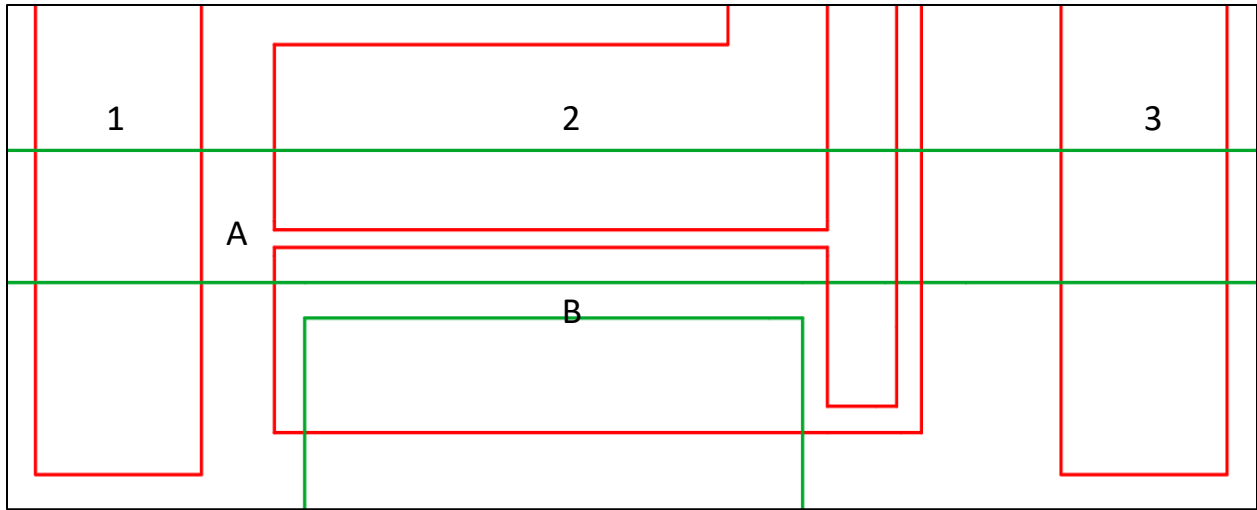

Figure 7. AutoCAD design of immobilization region of microfluidic microinjection chip. The red numerically labeled features are in the control layer. The green alphabetically labeled features are in the flow layer.

The section has five main components: the left flow control valve (1), the upper immobilization valve (2), the right flow control valve (3), the flow channel (A), and the microinjector membrane (B). Details on how this section operates can be found in Section 4.3.

2.3.4. Microinjection region

The microinjection region is located just below the immobilization region of the chip.

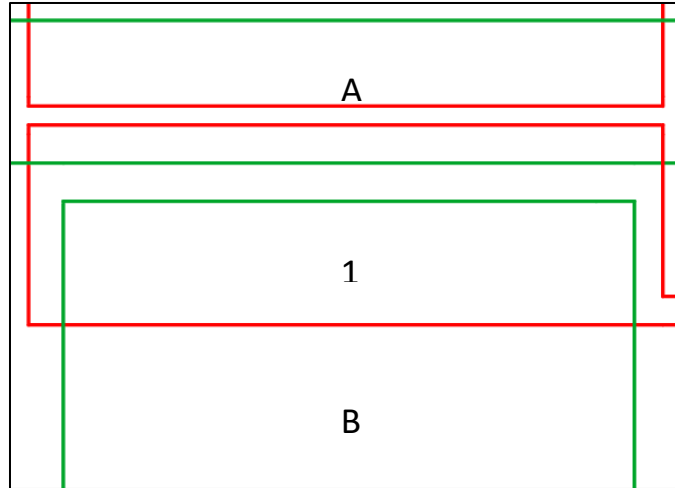

Figure 8. AutoCAD design of microinjector region of microfluidic microinjection chip. The red numerically labeled features are in the control layer. The green alphabetically labeled features are in the flow layer.

The microinjector region has two main features: the microinjector channel (B) and the microinjector valve (1). The flow channel is section A.

2.3.5. Offloading area

There are two output valves from the offloading area.

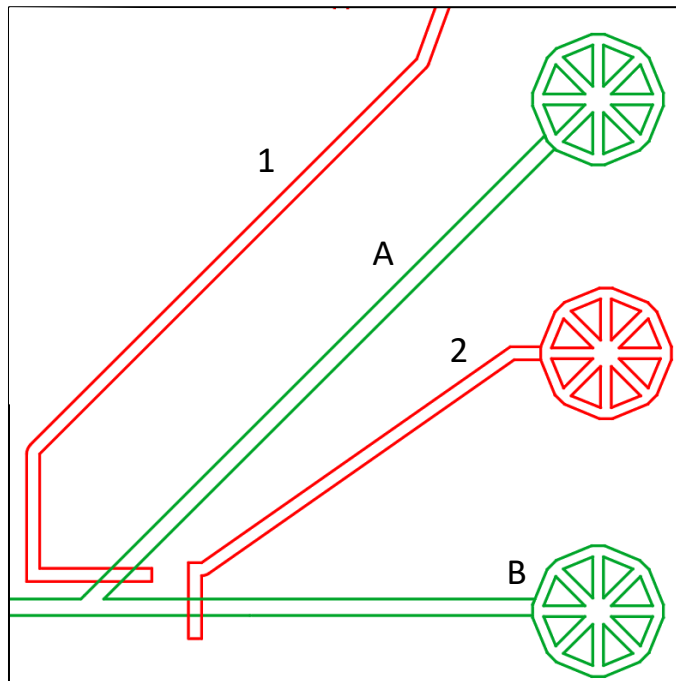

Figure 9. AutoCAD design of offloading region of microfluidic microinjection chip. The red numerically labeled features are in the control layer. The green alphabetically labeled features are in the flow layer. The input of valve A is not shown.

By turning Valve 2 on and Valve 1 off, flow is directed towards Channel A. By turning Valve 1 on and valve 2 off flow is directed towards Channel B. Depending on the predicted success of the microinjection, the worms can be either directed towards one output or another. At the end of the outputs for A and B, worms are then collected in tubes outside of the chip.

2.4. Expected results

Protocols for mask creation, photolithography, and soft lithography are very well established. Masks are created and printed using a user provided AutoCAD file. Photolithography results are detailed in all photolithography chemicals' respective data sheets. Soft lithography expected results are largely based off Dr. Araci's extensive knowledge of soft lithography.

2.5. Materials and methods

Chips are created via photolithography and soft lithography, and then tested using a microfluidic multiplexer.

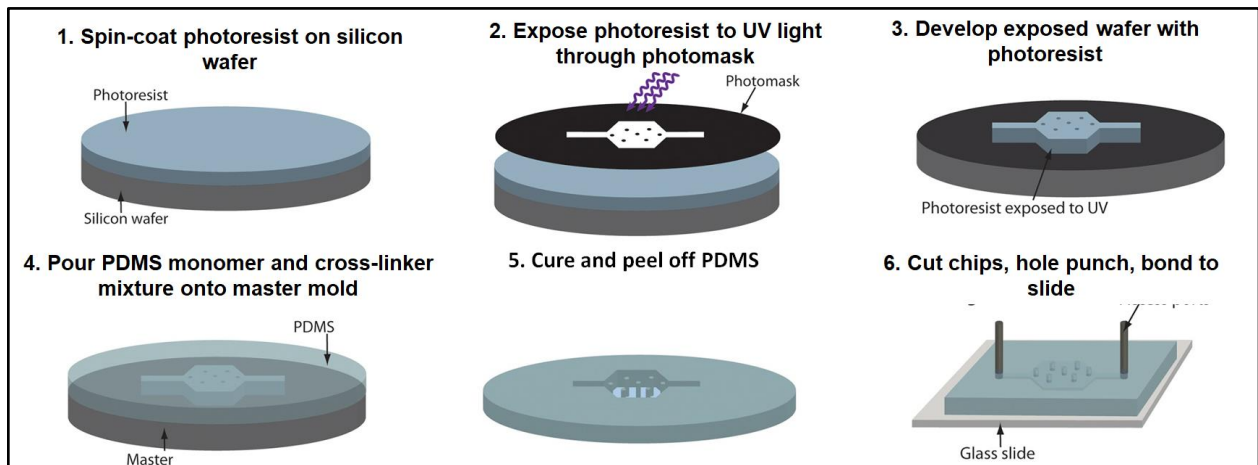

Figure 10. Overview of photolithography and soft lithography procedures.¹¹ Image adapted from [12].

¹¹ San-Miguel et al. "Microfluidics as a tool for *C. elegans* research." *WormBook* (2013).

Figure above shows the relationship between molds created via photolithography (1-3) and chips created from soft lithography (4-6). The processes depicted differ from our own in that they lack a control layer, thus only one photomask is used instead of our two.

2.5.1. Photolithography masks

Mask designs are created using Autodesk's AutoCAD software. The chips were designed to have two layers: flow and control. Masks had space for 10 total designs, some unique and some identical.

2.5.2. Photolithography procedure

Photolithography is completed using SU8-2050 for both the control and flow layers.

2.5.2.1. Control layer

Control layers are made to be 50 μm tall using the following procedure:

1. Spin SU8-2050 at 3100 RPM for 30 seconds
2. Soft bake for 3 minutes at 95°C
3. Expose for 15 seconds
4. Post-exposure bake at 95°C for 4 minutes
5. Develop for 2 minutes 30 seconds in SU8 developer
6. Hard bake using the following parameters: start at 65°C, end at 160°C, ramp up temperature at 120°C/hour, stop after 2 hours

2.5.2.2. Flow layer

Flow layers are 30 μm tall and manufactured via the following protocol:

1. Spin SU8-2050 at 5000 RPM for 45 seconds

2. Soft bake for 5 minutes at 95°C
3. Expose for 11 seconds
4. Post-exposure bake at 95°C for 3 minutes
5. Develop for 2 minutes 30 seconds in SU8 developer
6. Hard bake using the following parameters: start at 65°C, end at 160°C, ramp up temperature at 120°C/hour, stop after 2 hours

2.5.3. Soft lithography procedure

Soft lithography is created using PDMS.

2.5.3.1. Control layer

The control layer is made of 5:1 PDMS to curing agent. PDMS is poured over the control mold and then degassed. After curing for 1 hour at 80°C, PDMS is separated from the control mold, cut into individual chips, and hole punched in appropriate locations.

2.5.3.2. Flow layer

The flow layer is made of 20:1 PDMS to curing agent. The flow layer mold is placed in the spin coater, PDMS is poured onto the center of the wafer and spun at 1400 RPM for 1 minute and 15 seconds. PDMS height should be 50 μm . The mold is cured for one hour at 80°C.

After preparing the layers, the control layer chips are aligned over the flow layer mold using a microscope. Control channels must be facing down towards the PDMS of the flow layer. The final assembly is then put back in the oven to cure for 2+ hours at 80°C. The final chip assembly is then cut from flow mold, hole punched, and can be stored for later usage.

2.5.4. Plasma bonding treatment

Aligned chips must be plasma bonded to a glass substrate prior to testing. Using a plasma machine, chips and glass substrate are exposed to plasma for 30 seconds, and then treated surfaces are immediately sandwiched together. Successful bonding results in an inability to separate the PDMS chips from glass substrate.

2.5.5. Microfluidic multiplexer

Microfluidic function is controlled using a Microfluidic Multiplexer linked to Elveflow software.

2.6. Results and discussion

Successful completion of chip fabrication is evaluated using three main criteria: layer alignment, presence of sensitive features, and presence of channel collapse. Successfully created chips are properly aligned, have all the required sensitive features, and no channel collapse. Evaluations of this criteria is done using qualitative observations.

2.6.1. Layer alignment

Alignment is primarily judged off how the microinjector region valves overlay on the microinjector flow channel.

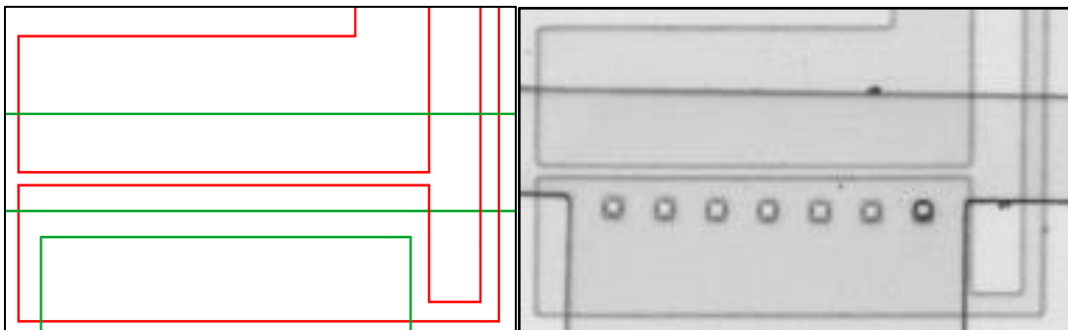

Figure 11. Flow and control layer microinjector region alignment. (Left) AutoCAD design showing proposed alignment of control layer (red) on top of flow layer (green) within the chip microinjector region. (Right) Actual alignment of control and flow layers within chip.

Figure 11 shows an example of successful alignment. Valves are below center of flow region (green), and lowermost completely covers thin membrane / teeth.

2.6.2. Sensitive features

The microinjector teeth / membrane area of our chips is the most sensitive in that they are the most difficult to fabricate. Due to constraints of photolithography, feature dimensions with an aspect ratio greater than 2 (feature height to feature width) are difficult to fabricate. Current protocols call for teeth dimensions that are 35 micron tall by 20 micron wide (aspect ratio of 1.75), which is at the limit of our aspect ratio (2).

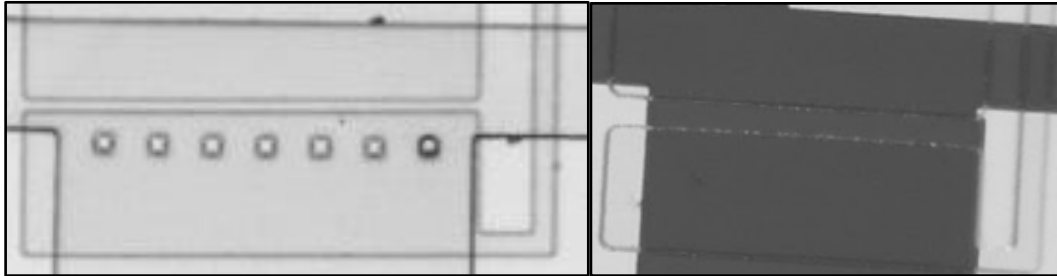

Figure 12. Test-filling flow layer of microinjector region with red dye. (Left) Flow layer of microinjector region prior to filling with fluid. (Right) Microinjector region filled with red dye (shown in grayscale).

Figure 12 shows an instance of failed photolithography. The teeth appear to present on the left, but fluid reveals that it can flow right over them. The likely cause is that the developer did not wash all unexposed SU8 out of the teeth holes, reducing their height and preventing the teeth from plasma bonding to glass substrate. Chips with thin, continuous membranes do not see this failure, as it is easier to wash out undeveloped SU8. In our final design, only chips with thin membranes are used.

2.6.3. Channel collapse

Channel collapse results in the permanent sealing or collapsing of a control valve, negatively impacting microfluidic behavior and controllability.

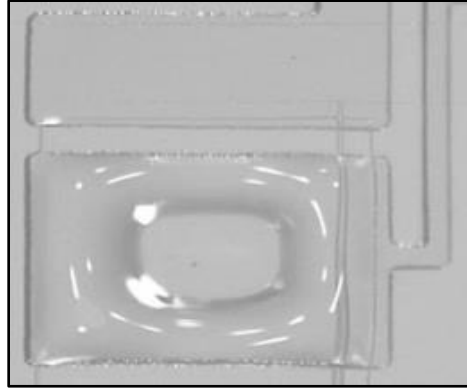

Figure 13. Image depicting extreme collapse of microinjector control valve. Valve is collapsed on top of needle tip embedded in membrane located between microinjection region and worm flow channel. Valve is collapsed as it is permanently plasma bonded to the floor of the flow layer.

Figure 13 shown above depicts an extreme case of microinjector valve collapse. Valve collapse can result from a valve being too large to support. The valve is 1000 μm wide but only 30 μm tall, with no support in the middle to keep the “roof” from falling down. Collapse may also result from pressing on the control channels during plasma bonding, resulting in their collapse and bonding to the glass substrate.

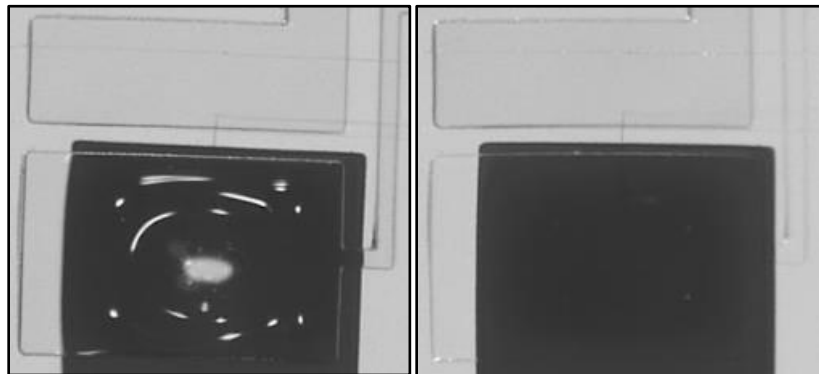

Figure 14. Reversibility of collapsed microinjection control valves under extreme pressure. (Left) Collapsed microinjector valve before application of pressure. (Right) Restored, non-collapsed microinjector valve after extreme pressure was applied to flow layer of microinjection region.

Figure 14 above indicates that in some cases, valve collapse can be reversed by applying extreme pressure to the collapsed valve from the flow layer. Collapse is seen in the left image and eventually removed, as evidenced by the right image. Despite collapse, all chips were found to function.

Chapter 3: *C. elegans* preparation and loading

3.1. Introduction

In order to test the functionality of the microfluidic microinjection chip, a synchronized population of *C. elegans* is necessary for testing. Worms must be at the young adult stage (between L4 and adult) for successful microinjection of genetic material¹². These worms are then prepared and loaded into the microfluidic chip at an acceptable concentration to ensure an even distribution throughout the chip.

3.2. Key constraints

Key constraints include:

1. maintaining a population of synchronized *C. elegans* hermaphrodites at the young adult stage,
2. using the correct buffer solution (M9) to ensure that worms survive moving through the microfluidic chip, and
3. loading the worms into the chip at an acceptable concentration to prevent clogging.

3.2.1. Constraint: Synchronized *C. elegans* population

A synchronized population of N2 hermaphrodites was needed for microinjection to ensure:

- (1) worms were the optimal stage for effective microinjection of genetic material, and
- (2) there was consistency of worm length and diameter for optimizing chip dimensions.

¹² Evans et al. "Transformation and microinjection." *WormBook*, (2006).

(1) For optimal microinjection and creation of a successful transformant, worms must be healthy, young adult hermaphrodites with a limited number of eggs¹³. See Figure 15 below for details regarding the relative ages and reproductive stages of the *C. elegans* life cycle. At this age, the worms are at the right reproductive stage for an injection to puncture and flood the distal tip of the worm gonad with the desired genetic construct (See Section 1.5: Figure 1 for more detail). This generates transformants when the newly forming oocytes encapsulate the injected genetic material.

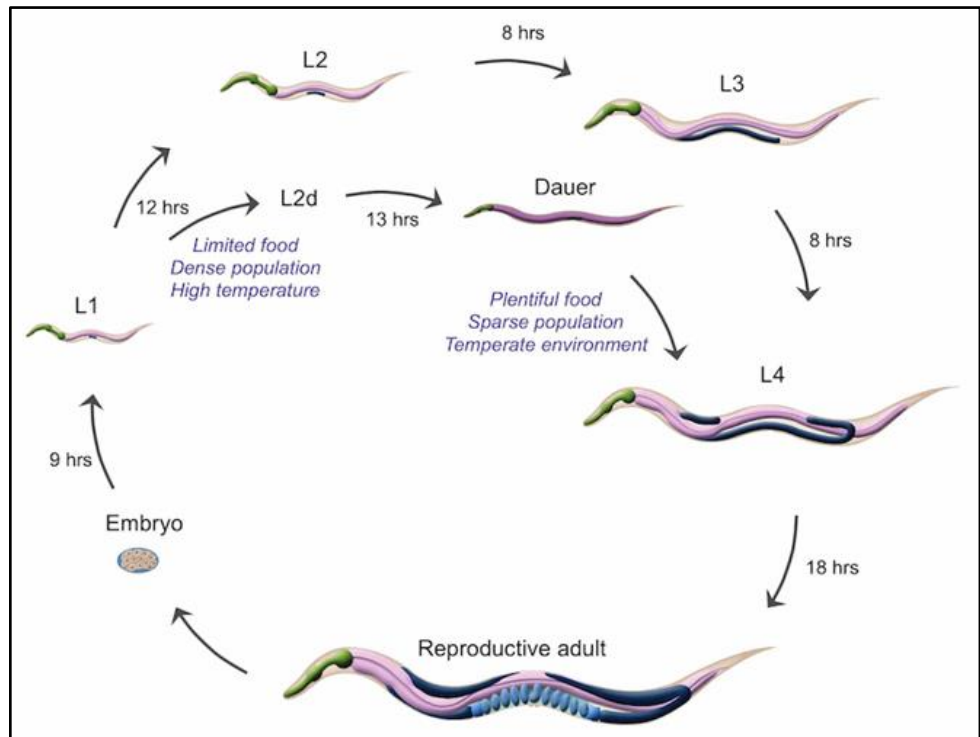

Figure 15. Life cycle of *C. elegans*. Life cycle schematic shows four larval stages of *C. elegans* (L1-L4), the temporary, hibernative-like dauer stage, and the reproductive adult stage. Time between life cycle stages at 23°C is listed adjacent to transition arrows. Diagram depicts relative sizes of each worm stage with young adults reaching a length of 1 mm and a width of 35-50µm. Reproductive adults are at the correct stage for microinjection. Image from Wolkow et al (2015)¹⁴.

¹³ Evans et al. "Transformation and microinjection." *WormBook*, (2006).

¹⁴ Wolkow et al. "Introduction to the Dauer Larva, Overview." *WormAtlas* (2015).

(2) Creation of a population of synchronized worms ensures that all worms in the chip have relatively consistent dimensions. This consistency is critical to optimize the microfluidic chip channel dimensions to allow for: (i) smooth worm flow through channels, and (ii) effective worm immobilization. For example, utilizing younger, and thus smaller, worms like L1 larvae (see Figure 15) could prevent control valves from effectively pinning down the worms for immobilization. The control valves might also be unable to prevent worms from escaping under actuated control valves. Additionally, older and larger worms might clog the chip channels.

3.2.2. Constraint: Maintaining *C. elegans* inside the chip

The worms must be suspended in a fluid to be loaded into the microfluidic chip and pushed through the chip's channels. In the lab, the worms are generally grown on Nematode Growth Medium (NGM) agar plates covered in a lawn of *E. coli* (OP50) bacteria¹⁵. The worms must be washed off these plates and into an M9 buffer solution before they can be inserted into the chip. Although the M9 solution does not contain a food source, the worms can survive in solution for a few hours while the experiment is in progress.

3.2.3. Constraint: Loading worms at acceptable concentration

When preparing to load the chip for microinjection, the worms must be washed off of their NGM agar plate and into a 1.5 ml tube. The number of worms per plate is fairly consistent within each population, therefore it is important to wash off the worms in the same amount of M9 buffer to ensure a relatively consistent concentration of worms. If the concentration of worms gets too high, the worms will flood the micropillar array and

¹⁵ Stiernagle et al. "Maintenance of *C. elegans*." *WormBook*, (2006).

clog the chip's channels. See Figure 16 below for an example of an acceptable worm concentration within the chip tubing.

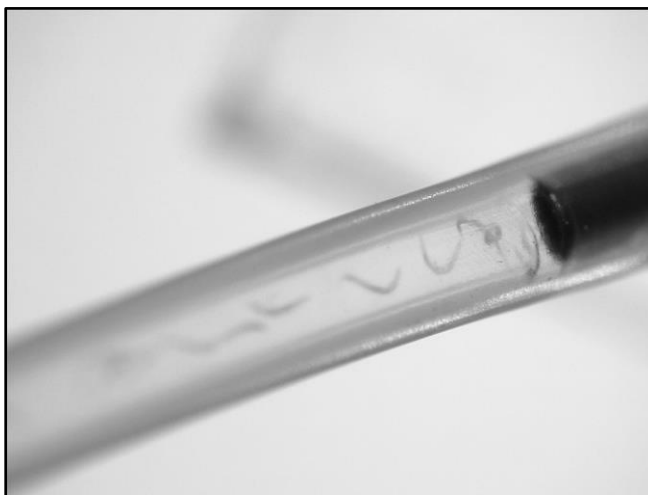

Figure 16. *C. elegans* inside of microfluidic chip tubing. Worms are at the young adult stage and are suspended in M9 buffer solution. Loaded into 200 μm diameter plastic tubing for insertion into microfluidic inlet ports.

3.3. Detailed design description

3.3.1. *C. elegans* maintenance

For our experiments, we used a strain of wild type *C. elegans* worms called N2¹⁶ (see Appendix B for details), as they are a common strain that is both easy to maintain and fairly robust for chip tests. They have a generation time of roughly 3 days at room temperature (23°C) and a brood size of around 350. Worms were grown at room temperature on Nematode Growth Media (NGM) agar plates spread with a lawn of OP50 *E. coli* (See Appendix C for NGM plate protocol details).

3.3.2. *C. elegans* age synchronization

As stated in Section “3.2.1 Synchronizing *C. elegans*,” a synchronized population on N2 hermaphrodite worms is needed for microinjection because (1) it ensures consistency of worm length and diameter for

¹⁶ <https://cgc.umn.edu/strain/N2>

optimal chip performance, and (2) worms must be at the young adult stage for microinjection of genetic material to be effective. The worms were synchronized using a hypochlorite solution procedure. The procedure takes gravid N2 hermaphrodites and immerses them in a hypochlorite solution to kill the adults while leaving behind the eggs (which are bleach resistant). These eggs are allowed to hatch in media without food. Starved L1 larvae will arrest until fed. Upon introduction of food, these larvae will resume development from the same point, resulting in a synchronized worm population. This process was repeated prior to each chip test to ensure consistency of worm age and size. Waiting 3 days after synchronization yielded worms at the desired young adult stage.

3.3.3. Loading *C. elegans* into chip

When an NGM agar plate covered in young adult hermaphrodite worms is ready for injection, the plate is washed with 1.0 mL of a worm-compatible solution called M9 buffer (an anesthetic such as levamisole can be added to M9 buffer if desired). Using the same 1.0 mL of fluid, the plate is rinsed 3-4 times before transferring the worm-containing solution into a 1.5 mL centrifuge tube. To load the worms into the chip itself, the inlet tubing is attached to a syringe and first filled with the worm-containing solution, then loaded with pure M9 buffer. When the inlet tubing is connected to the chip, this allows the pure M9 buffer to flush the channels before the worms begin to enter.

3.4. Results and discussion

For all chip tests, worms were maintained in large, synchronized populations. Chip tests were conducted using young adult hermaphrodites. To load the worms into the chip, they were washed off their NGM plates in M9 buffer, pulled into microfluidic tubing using a syringe, and then inserted into the chip via its inlet ports. Analogous to this loading procedure, the worms must be removed from the chip post-injection. (See Appendix D for a subset of experiments that attempted to

utilize a magnetic levitating cell-sorter by LevitasBio to sort living versus dead worms exiting the chip outlet). Outlet tubing was allowed to drip M9 buffer + worm solution freely onto NGM plates (without *E. coli* food source). The liquid was allowed to dry before the live worms were picked and moved to a new NGM plate with *E. coli* food.

Chapter 4: *C. elegans* Immobilization

4.1. Introduction

Prior to microinjection, the worm must be properly immobilized. Failure to properly immobilize the worm makes targeting the gonad nearly impossible. Additionally, improper immobilization increases the probability that the microinjection needle will tear and kill the worm. Thus, it is paramount that the worm's motion through the chip is highly controlled and that it is completely immobilized for injection.

4.2. Key constraints

4.2.1. Cannot use negative pressure system controls

Our chip does not use negative pressure system controls. Most microfluidic chips achieve microinjection through negative control systems to immobilize worms. Negative control systems allow worms to get sucked into smaller channels or get stuck against walls with gaps to immobilize the worms. The microfluidic lab that we worked in did not have these control systems. Therefore, in an effort to keep our project accessible to as many labs as possible, we avoided using such systems.

4.2.2. Only using positive pressure system controls

Positive pressure controls are the most widely available pressure control systems in microfluidics. Our project therefore aims to achieve immobilization using only positive pressure control valves. Enough pressure on a control valve should be sufficient to immobilize a worm on or against a microinjection needle¹⁷.

¹⁷Ardeshiri et al. "A hybrid microfluidic device for on-demand orientation and multidirectional imaging of *C. elegans* organs and neurons." *Biomicrofluidics* (2016).

4.3. Proposed analysis and expected results

4.3.1. Immobilized worm motion measurements

Success of immobilization is frequently measured by examining how much motion is seen in the worm. Measurements are frequently taken in the x-axis (how much the worm moves left and right in the above image), and the y-axis (how much the worm moves up and down in the above image). Measurements magnitudes are taken in the micron scale.

4.3.2. Anticipated results

Current chip design only immobilizes the mid-section of the worm, where the gonad is located. The immobilization valve (2) is not the entire length of the worm. We therefore expect to see significant movement around the head and tail region of the worm, and hopefully very little movement in the middle of the worm while it is pressed against the membrane.

4.4. Back-up plan

Failure to immobilize will result in fewer successful transformants. If immobilization fails, microinjection can still be performed, but the ability to hit the gonad with a ~30% success rate will be diminished. As such, researchers will spend more time attempting to get a successful injection, though even with a reduced success rate throughput should still allow for more successful injections per unit time than traditional methods.

4.5. Materials and methods

The immobilization section of the chip has two main units, the left, upper, and right control valves, and the flow channel and membrane of the fluid layer.

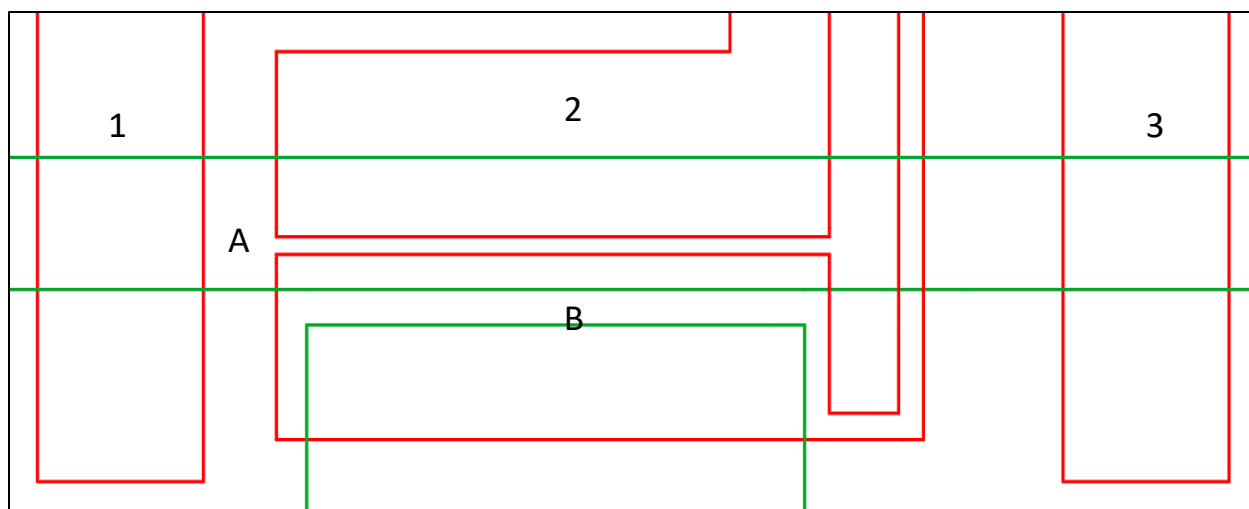

Figure 17. AutoCAD schematic showing flow and control layer design in immobilization region. The red numerically labeled features are in the control layer. The green alphabetically labeled features are in the flow layer. The immobilization section has five main components: the left flow control valve (1), the upper immobilization valve (2), the right flow control valve (3), the flow channel (A), and the microinjector membrane (B).

The rightmost valve (3) is pressurized so that liquid can flow past the valve, but the worm cannot. Once a worm has reached this valve, the leftmost valve (1) is sealed to prevent an additional worm from entering the area. The upper valve (2) is then used to immobilize the worm by pressing it against the membrane (B). At this point, the worm is at its most immobilized, and is ready for injection. After injection, the upper immobilization valve (2) releases the worm from the membrane, and the rightmost valve (3) releases to let the worm exit the chip. The leftmost valve (1) is then opened again to allow for a new worm to enter the chip.

4.6. Results

Figure 18 below shows an adult worm before and after actuation of the upper immobilization valve. These results suggest that immobilization using positive pressure is relatively successful—post-valve actuation, the worm’s body is completely straight and pinned. The worm is incapable of any significant body movement. However, immobilization using this method did show considerable movement in the head (right) region of the worm. This method also showed that the worm could be effectively immobilized between just two valves. In the above

figure, the teeth are not functioning. As discussed in Section 2.6.2, improper photolithography made the teeth shorter and failed to plasma bond.

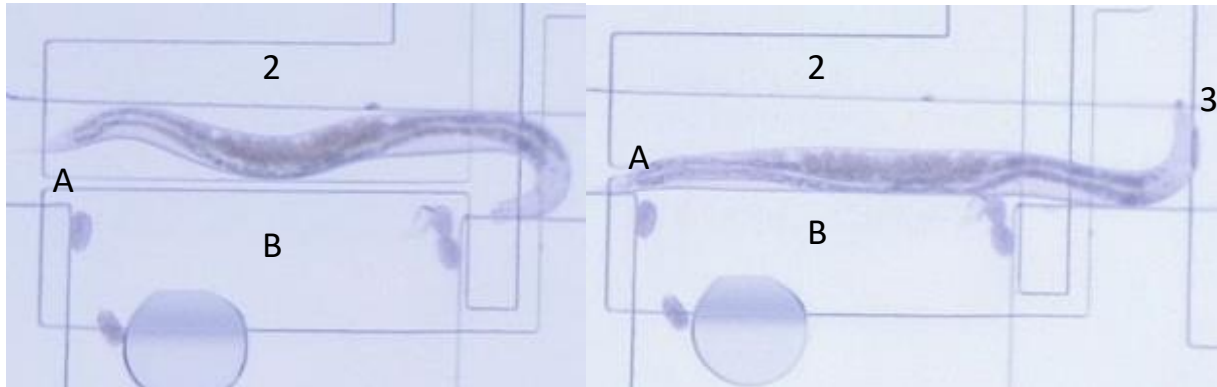

Figure 18. Immobilization of *C. elegans* worms utilizing actuated control valve. (Left) Worm pre-immobilization shown locked into microinjection region of chip. Control valves on either end of the worm (valves 1 and 3 are out of view) are actuated to keep worm floating within microinjection region. (Right) Worm post-immobilization. Worm is pressed against PDMS teeth (B) separating the worm flow channel from the microinjection region chamber. An actuated control valve located directly on top of the worm (valve 2) is actuated to press the worm down and into the teeth. Lower microinjector valve (See Section 2.3.4) also actuated. Numbers and letters correspond to AutoCAD drawing shown in Figure 17.

4.7. Discussion

Qualitative observations of immobilization suggest success regardless of teeth presence. Immobilization was seen along the body of the worm, and not in areas unaffected by valve actuation. Current observations are not conducive to gathering quantitative data. Generating data about average movement ability is made more difficult with the low resolution of microfluidic microscopes. Data may be changed into qualitative movement data (did the worm move enough to be seen or not), and then analyzed appropriately.

Chapter 5: Microfluidic Microinjection of *C. elegans*

5.1. Introduction

To design a microfluidic microinjection device without external components, we needed to develop a novel, on-chip microinjection apparatus. To do this we embedded a portion of a microinjection needle into a PDMS membrane within the chip (Figure 19) that could inject an immobilized worm within the chip's flow channel (Figure 19C). By filling the microinjection region with a genetic construct and then pressurizing the chamber, the needle + membrane would deflect into the worm and fluid would be injected into the worm. Additionally, by pressurizing the control valve located directly above the worm, the worm would be simultaneously immobilized against the thin membrane and pushed into the fluid-ejecting needle. See Figure 19 below for the concept schematic of our novel, on-chip microinjector.

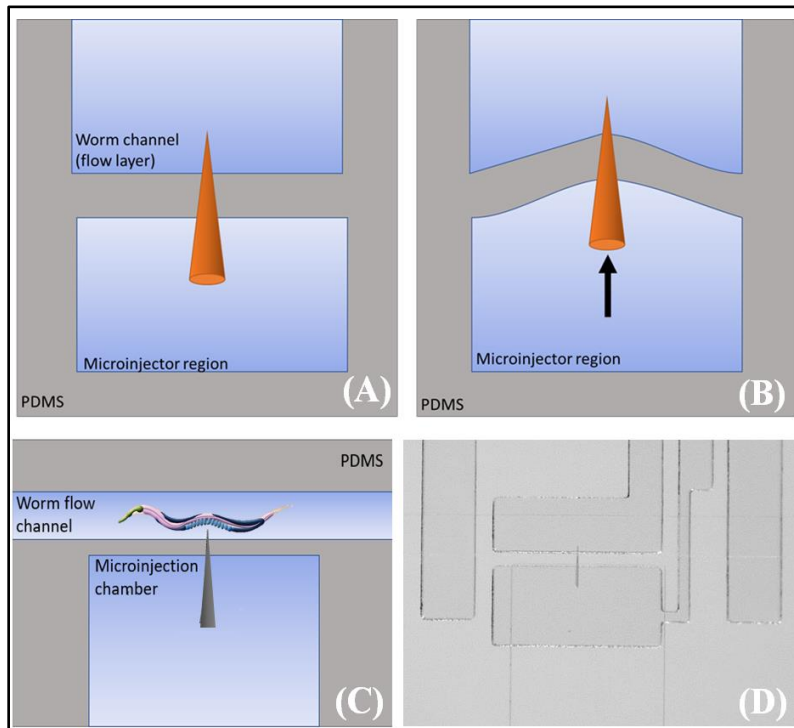

Figure 19. Concept design for novel, on-chip microinjection chamber. (A) Embedded needle tip in membrane separating microinjection region (filled with genetic construct) and worm channel. (B) Microinjection region pressurized to deflect needle and expel fluid. (C) Schematic showing embedded needle alongside worm. (D) Actual image of embedded needle tip.

We were able to establish proof of concept for our novel microinjection chamber by successfully injecting red dye into a worm.

5.2. Key constraints

In order to create a novel, optimized microinjection apparatus, we needed to address the following six constraints:

1. Needle tips must be pulled consistently.
2. Needle tips must be broken correctly and consistently prior to embedding.
3. Needles must be inserted deeply enough into the PDMS membrane to ensure needle security but not so deeply that worms are accidentally impaled in the flow channel.
4. PDMS membrane thickness must be optimized to ensure good needle security and stability without compromising membrane deflection.
5. Pressure optimization in the microinjector chamber must ensure that the correct volume of liquid (and eventually DNA reagent) is expelled from the needle in the correct amount of time.
6. The immobilization valves must be able to hold the worm in place while needle is deflected into the gonad.

5.3. Detailed design description

5.3.1. Needle preparation and insertion into membrane

5.3.1.1. Pulling microneedles from glass capillaries

Two microneedles are pulled from one 1 mm diameter borosilicate glass capillaries (Kwik-Fil Item#1B100F-4). Two microneedles are made using the Flaming / Brown Micropipette Puller Model P-87 and the following parameters: Heat: 600, Pull: 40, Velocity: 55, Time: 130, Pressure: 500. See below for image of Micropipette Puller pulling 2 microinjection needles from a single capillary.

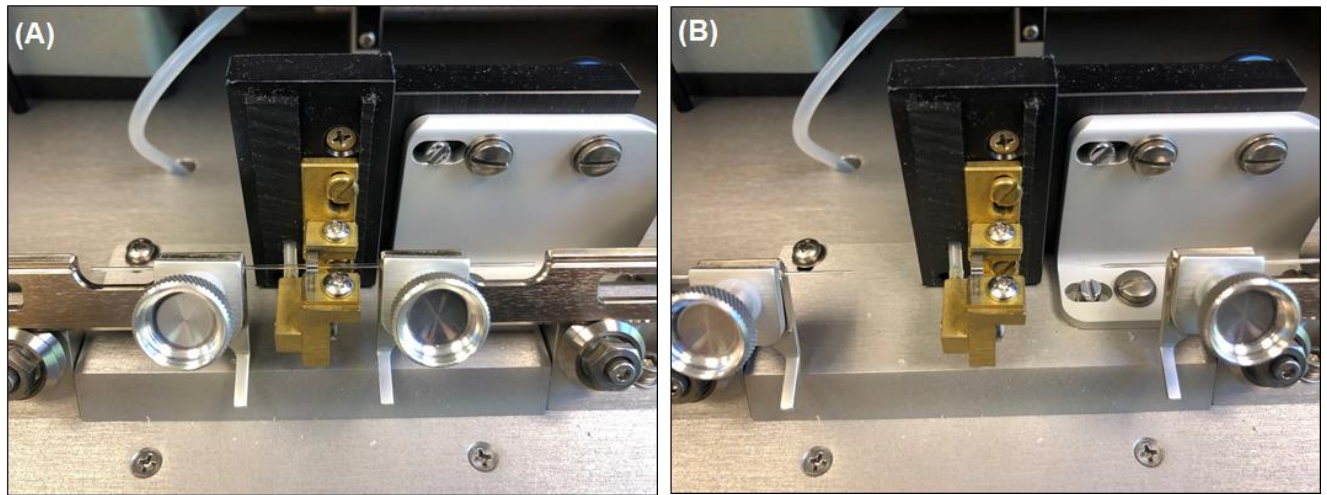

Figure 20. Brown Micropipette Puller pulling two glass microinjection needles. (A) Heating element glowing orange as it heats the glass borosilicate capillary pre-pull. (B) Post-pull microinjection needles.

To ensure that the needle tips are identical, the glass borosilicate capillary must be carefully centered in the micropipette puller and secured using the knobs shown in Figure 20 shown above. If done correctly, one glass capillary will yield two virtually identical microinjection needle tips. Note that glass pulling generally produces needles whose tips are sealed or melted shut. The tips must be broken before being used for microinjection.

5.3.1.2. Breaking sealed needle tip

Sealed microneedle tips must be broken prior to insertion in the chip or they will not be able to inject fluid into the worms.

1. Place a drop of halocarbon oil on a glass microscope slide.
2. Place a coverslip over the drop of oil and allow oil to spread past the edge of the coverslip.
3. Place prepared slide on microscope stage.
4. Attach microneedle to micromanipulator.
5. Drag needle tip along the edge of the coverslip until the needle breaks. The user should see oil flow into the needle tip. Alternatively, the needle can be preloaded with fluid

and the user can test whether the needle is appropriately broken by attempting to eject liquid (this is the method utilized in standard, manual microinjection). This is shown in below in Figure 21D.

6. Remove needle from the micromanipulator and store.

See Figure 21 below for visual depiction of tip breaking procedure.

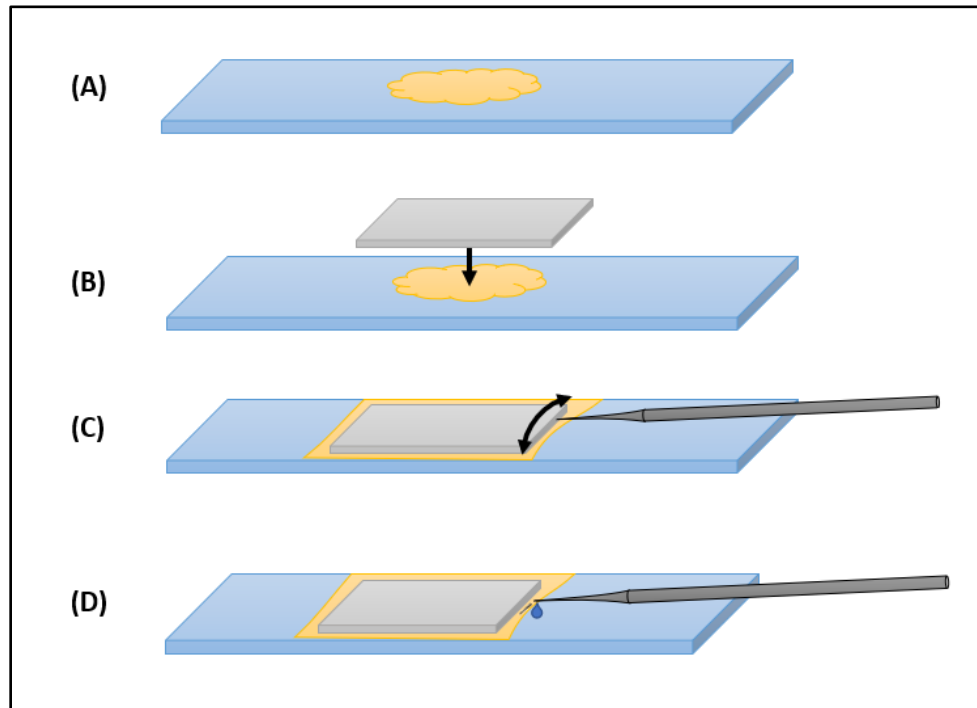

Figure 21. Breaking of glass microinjection tip to allow fluid flow. (A) Halocarbon oil drop on glass slide. (B) Place coverslip over oil droplet. (C) Lightly drag the sealed glass needle tip against the coverslip edge. (D) Barely break the needle tip to allow fluid flow.

5.3.1.3. Cutting needle tip fragments for on-chip injection

Unsealed needle tips must be broken (see section 5.3.1.2 above) so that embedded needle tips can eject liquid inside of the chip.

1. Place 0.5" by 0.5" chunk of 5:1 (pre-polymer: crosslinker) fully cured PDMS on a glass slide.
2. Set freshly broken needle with tip resting on PDMS chunk and tape down base-end of needle to slide (Figure 22 A, B).

3. Overlay 0.5" by 0.5" chunk of fully cured, 300 μm thick, 10:1 (pre-polymer: crosslinker) PDMS on top of the 5:1 PDMS chunk. Gently tamp down 10:1 PDMS layer to ensure contact on either side of needle tip (Figure 22 C).
4. Cut microneedle tip to desired size using a razor blade. Cut perpendicular to the needle all the way through both PDMS layers to ensure needle fragment remains intact (Figure 22 D, E).
5. Using tweezers, remove the top 10:1 layer of PDMS, checking carefully to see which layer of PDMS the needle fragment has adhered to. Move the PDMS chunk + needle fragment to a scope with needle/micromanipulator attachment.
6. Attach a fresh, unbroken "guide" needle to the micromanipulator. Guide the fresh needle into the back of the needle fragment to pick it up.

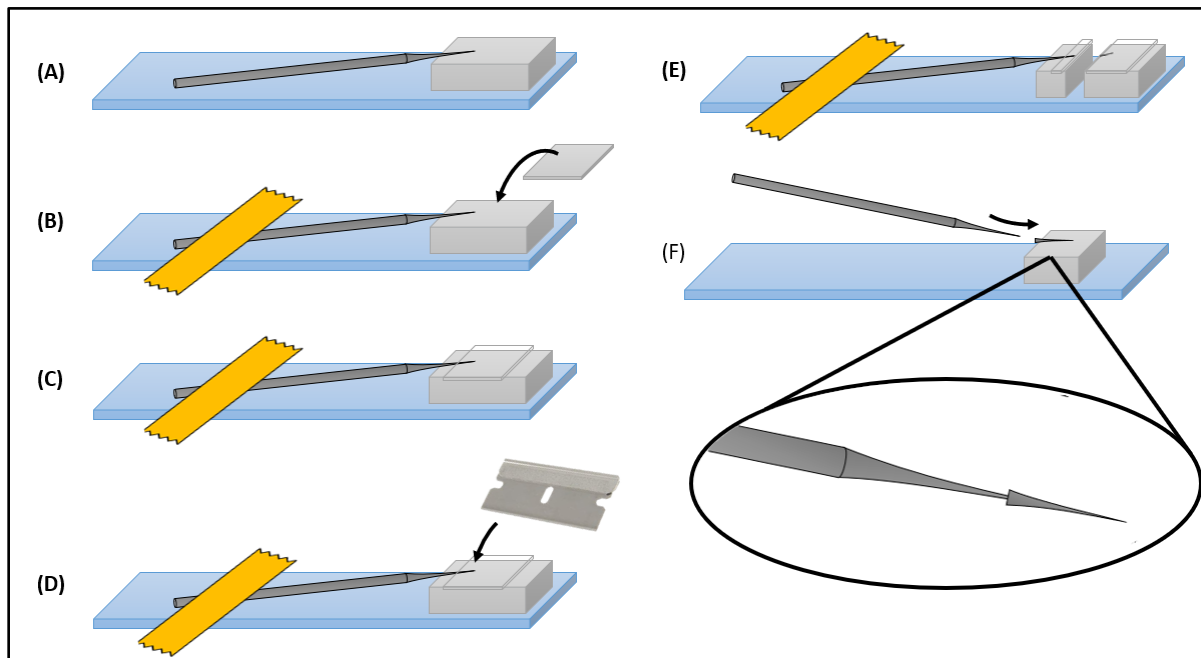

Figure 22. Cutting needle tip fragments used for on-chip microinjection. (A) Place freshly broken needle with tip resting on 1:5 chunk of PDMS. (B-C) Tape down needle base and place thin (300 μm) layer of 10:1 PDMS on top of needle tip. (D) Use a razor blade to manually cut straight down (perpendicular to the needle tip) through both PDMS layers to break off desired needle tip length. (E-F) Separate PDMS chunks containing needle fragment, peel off 10:1 PDMS layer to reveal tip fragment, and insert fresh "guide" needle into base of needle fragment to pick it up.

5.3.1.4. Embedding needle fragments into membrane of microinjector chamber

With the broken needle tip securely resting on the guide needle tip, the guide needle can be used to bury the broken needle tip into the PDMS membrane separating the microinjector chamber and the worm flow channel (Figure 23). To do this, the PDMS chip (flow + control layer) must be placed upside down so that the needle pair can reach inside the chip to the membrane of interest.

Once the needle tip has been embedded in the membrane, tension must be placed on the tip so that the guide needle can slide out and be removed. This is accomplished by laying a ~100 um protective piece of 10:1 PDMS on top of the microinjector region and then pressing down gently on the needle tip through the protective PDMS. (Note: Without the protective PDMS layer, pressing on the needle tip will either shatter the glass or slide the tip out of the membrane.) While pressing down gently on the needle tip, the guide needle can be retracted and then the protective PDMS layer can be removed. Note that it is easier to slide out the guide needle if you take care not to jam the guide needle into the broken tip when you first pick it up. To finalize the chip, the PDMS chip + embedded needle must be plasma bonded to a glass slide to seal the microinjection chamber. See figure below for a visual description of the needle embedding process.

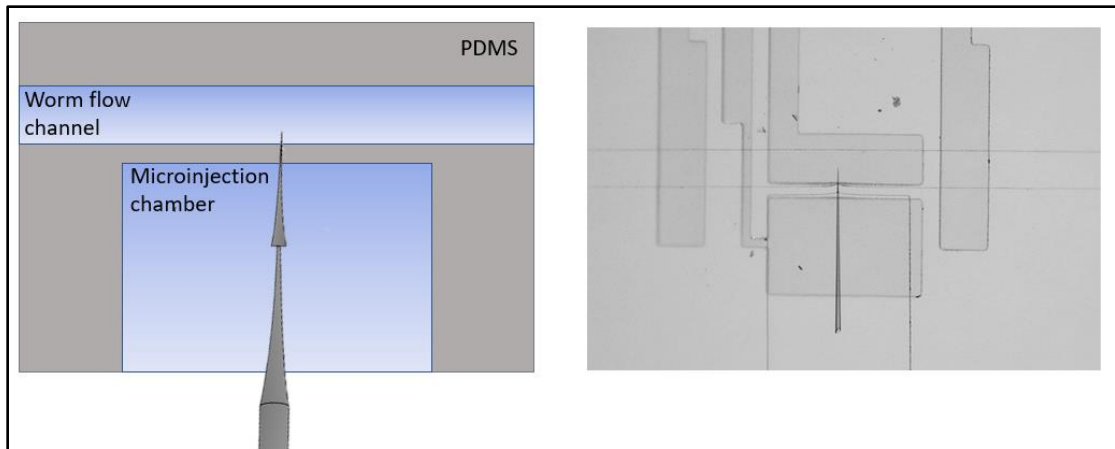

Figure 23. Embedding needle tip fragment into thin membrane of microinjector region. (Left) Schematic of using “guide” needle to insert needle fragment into thin membrane. (Right) Top-down view of microinjector region with embedded needle fragment after the guide needle has been retracted.

5.3.1.5. Needle tip flow testing

With the needle tip firmly lodged in the membrane separating the microinjection region and the worm’s flow channel, we needed to test whether pressurizing the microinjection region would eject fluid from the needle. Preliminary results showed that red food dye can be successfully expelled through the needle at a pressure range of 15-30 psi. Additionally, even at very high pressures, the dye was ejected only through the needle tip and did not leak around the base of the needle tip. See Figure 24 below to see ejection of red food dye through the needle at 20 psi.

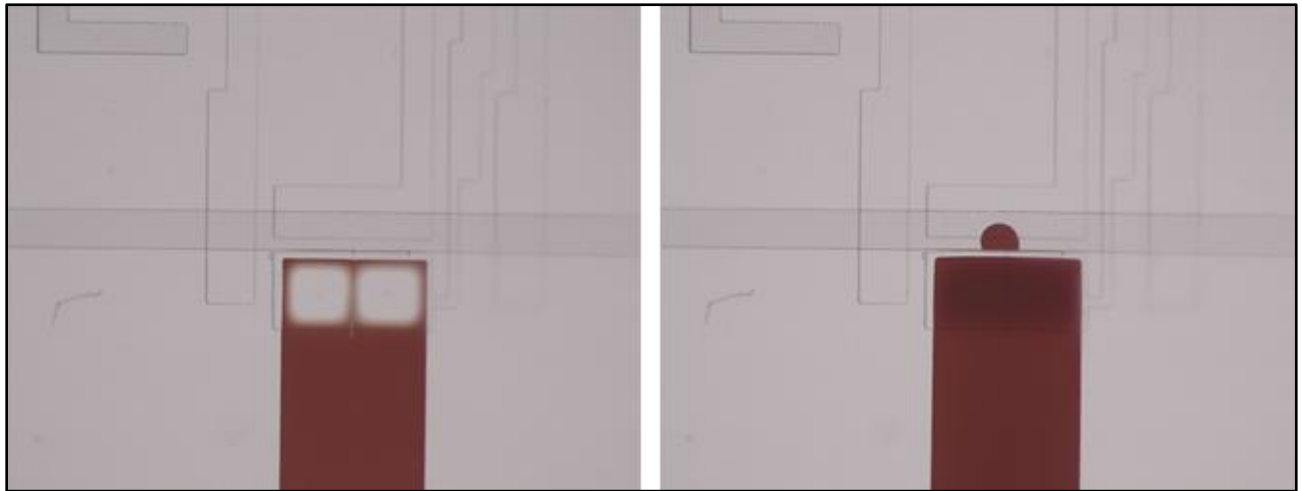

Figure 24. Ejection of red food dye through embedded microneedle tip. (Left) Image taken prior to pressurization of the microinjection region. White area around needle indicates that the control valve located on top of the microinjection region is actuated. (Right) Post-pressurization of the microinjection region at 20 psi. Control valve on top of microinjection region is no longer deflected because of the equal pressure between the microinjection region and control valve.

5.4. Results

With needle tips firmly embedded in the microinjector membrane and proof that liquid ejection was possible, we attempted preliminary microinjection attempts with a synchronized worm population. Unfortunately, our worm population was too old (worms had fully developed oocytes), however, we were able to successfully inject 10 worms with red food dye using our novel microinjection apparatus. See Figure 25 below to see the before and after of a successful injection of an older adult worm.

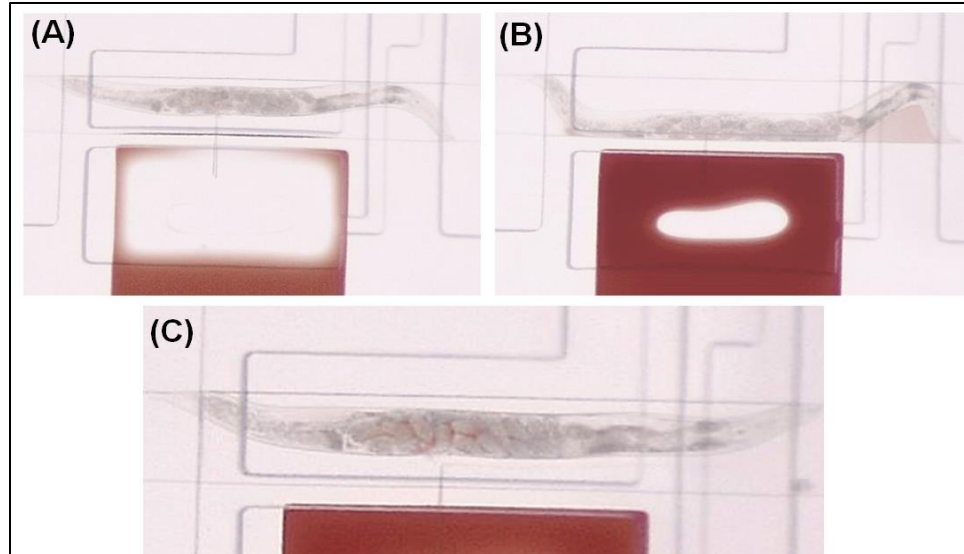

Figure 25. Injection of red dye into *C. elegans* using novel on-chip microinjector. (A) Pre-injection. Adult worm trapped in microinjector region with valves on either side actuated. (B) Mid-Injection. Control valve located directly on top of worm is actuated to immobilize and press worm into the fluid-ejecting needle tip. (C) Post-injection. Red dye can be seen inside of worm body surrounding the developed oocytes.

To inject, we used the following procedure:

1. Load worm into microinjector chamber and trap it by actuating the control valves located near its head and tail.
2. Test the microinjector by pressurizing the microinjection region until a red plume appears beneath the worm.
3. While ejecting dye, actuate the control valve located on top of the worm in the flow channel to immobilize and press the worm into the fluid-ejecting needle tip.
4. While still ejecting fluid, de-pressurize the control valve that is immobilizing the worm to allow the worm to slide off the needle.
5. As the worm slides off the needle, red dye seeps into its body, likely due to the slight negative pressure created inside the worm during the injection procedure.

5.5. Discussion

Preliminary injection results are promising and serve as a proof of concept for our novel, on-chip microinjector. However, the system we have designed is quite

complex and it requires additional validation steps. Some of the aspects of our design that require further optimization and analysis are:

- (1) Pressurization of the microinjection region and how it affects membrane deflection versus fluid ejection. By coupling the processes of needle deflection and fluid ejection, we have created a mathematically complex problem to solve.
- (2) Actuation of the control valve located on top of the microinjection region. It has the potential to alter the angle as well as the fluid-ejection capacity of the needle that protrudes into the worm flow channel.
- (3) Worm survival rate post-injection. We need to analyze how this immobilization + compression-injection affects worm lifespan.
- (4) Injection of actual genetic construct (not food dye) to generate successful transformants.

Chapter 6: Chip Validation - COMSOL Simulation of Microinjector Region

6.1. Introduction

To predict whether the thin membrane + embedded microneedle would be able to deflect enough to microinject and to visualize the effect of a pressurized valve on embedded needle movement, we needed to conduct simulations using COMSOL.

COMSOL, a multiphysics software, uses finite element analysis to provide a model and simulation system. To obtain a range of membrane deflection values, the microinjection region was modeled in COMSOL. In COMSOL, parameters such as pressure and membrane thickness, can be swept over a range to predict the resultant deflection outputs. Then, in order to visualize the embedded needle movement, a side-view cross section of the chip was modeled in COMSOL. Varying the pressure of surrounding chambers can provide valuable insight as to how the needle will react when we pressurize the chambers in our chip.

6.2. Key constraints

The membrane deflection range and behavior of the embedded needle are constrained to the multiphysics software of COMSOL. While COMSOL provides the tools to model the deflections associated with the microinjection region of the chip and the pressurized chambers effect on the movement of an embedded needle, it is only a theoretical simulation. The physical microinjection chamber and embedded needle will not necessarily behave according to the ideal conditions of the simulation. Additionally, the movements and reactions of *C. elegans* animals are not fully predictable.

6.3. Detailed design description

6.3.1. Microinjection region for membrane deflection simulation

The microinjection region of the chip can be modeled simply by using an assortment of blocks with dimensions matching the chip. The model, as

seen in Figure 26, consists of six total blocks to create a glass base, walls surrounding an open chamber, and a thin membrane to top the chamber. In the physical chip, however, there is no glass base backing the chamber, so the sturdy properties of glass are used to mimic the thick PDMS base relative to the thin membrane.

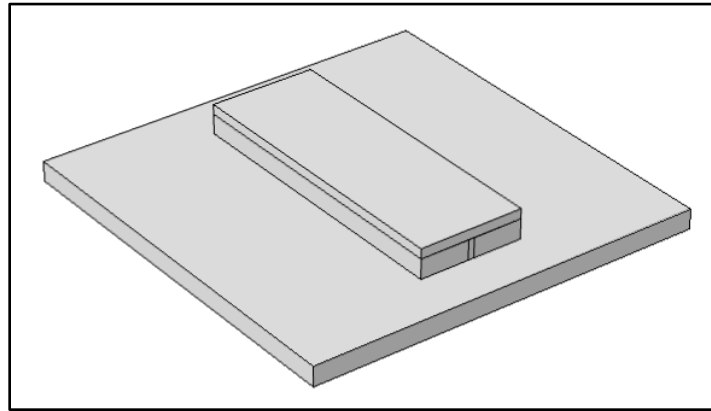

Figure 26. COMSOL model of microfluidic microinjection region based on a glass model. The fully constructed COMSOL model of the microinjection region for our chip. The top-most surface is the thin membrane between the microinjection chamber and the worm flow channel.

COMSOL allows model parts to be hidden to show interior structures. Figure 27 shows the highlighted chamber once the glass base has been hidden.

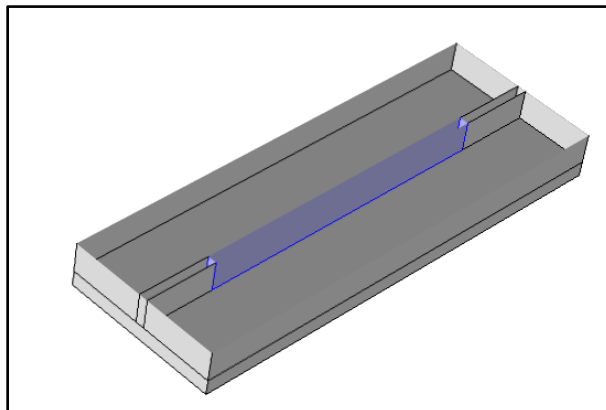

Figure 27. COMSOL model of microinjection region chamber. Inner chamber of the microinjection region after the glass had been “hidden” in COMSOL and the chamber surfaces had been selected.

To simulate the bonded nature of the chip, once created, the blocks were mated. This mating was important to simulate the fully bonded chip. The model now functions as a single unit. To distinguish the glass base from the PDMS, materials were assigned to blocks. The PDMS has a Young's modulus of 1000 kPa, a Poisson's ratio equal to 0.49, and a density of 1000 kg/m³. The glass only increases in the Young's modulus value from 1000 kPa to 1000 MPa.

6.3.2. Embedded needle for needle movement simulation

To simplify the model of needle movement, COMSOL was used to model the side-view cross-section of the chip. As shown in Figure 28, the model uses an assortment of rectangles that resemble the chip dimensions.

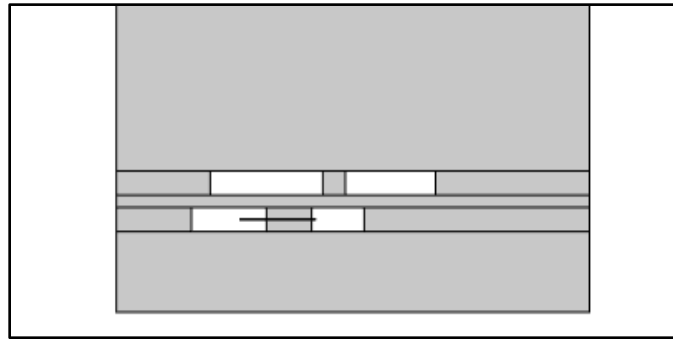

Figure 28. COMSOL model showing effect of control valve on embedded needle movement. Two-dimensional model of the chip used for studying the movement of the needle embedded in the thin membrane.

Similar to the microinjection region, these rectangles were mated to mimic the bonding of the layers. Then, assigning materials helps to distinguish the rectangles so that each contributes to a model that more closely resembles the true nature of the chip. Using the same material properties for the glass and PDMS materials as the three-dimensional microinjection chamber model, the base rectangle and the thin rectangle, that appears to be a line through another rectangle, are glass. The base rectangle is the glass base, and the thin rectangle represents the embedded needle. The remaining rectangles are PDMS.

6.4. Simulation methods

6.4.1. Membrane deflection simulation

Deflection values for the membrane were obtained while varying the chamber pressure and the membrane thickness. COMSOL contains a function called “parametric sweep” that computes simulations for a range of desired values. To use this function, the variables or parameters must first be defined. Under the global definitions, we defined pressure and membrane thickness as parameters. Then, the set value for these parameters must be changed to the parameter name. Once set up, we computed the parametric sweep then we evaluated the results for maximum deflection. This was done for three models with differing membrane thicknesses—1 μm , 50 μm , and 1000 μm .

6.4.2. Needle movement simulation

The needle movement simulation is more ambiguous. In theory, the microinjection chamber and the valve above this chamber will be pressurized over a range of pressure inputs to study the reaction of the needle. However, because COMSOL is a multi-physics simulation software, certain interactions must be more explicitly defined. At high enough pressures in the top chamber, deflection of the membrane will touch the needle. This interaction is not defined in COMSOL. Yet, COMSOL contains a function called “contact pairing” that can resolve the interaction problem between the membrane and the needle. Once the surfaces are paired, then the pressure values can be swept to evaluate the needle movement.

6.5. Results and discussion

6.5.1. Membrane deflection

When we computed the parametric sweep that simulated the pressurization of the microinjection chamber, we saw clear deflection across the thin membrane. This deflection simulation is pictured in Figure 29.

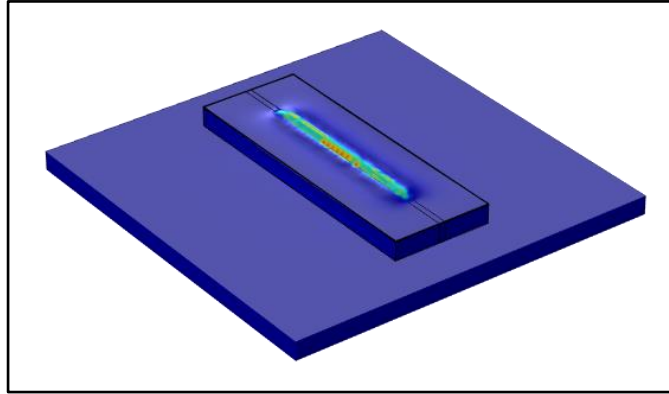

Figure 29. COMSOL model depicting the membrane stress that results from applying a boundary load to microinjection chamber. The dark blue areas of the model are not stressed. The light blue and orange areas show stress and deflection of the thin membrane. The orange indicates increased stress, revealing maximal stress located in the center of the thin membrane

Once deflection was observed in the model, the simulation was evaluated for maximal membrane deflection. For the three different models with varying membrane thickness, the maximal deflection was plotted against the input boundary load as shown in Figure 30.

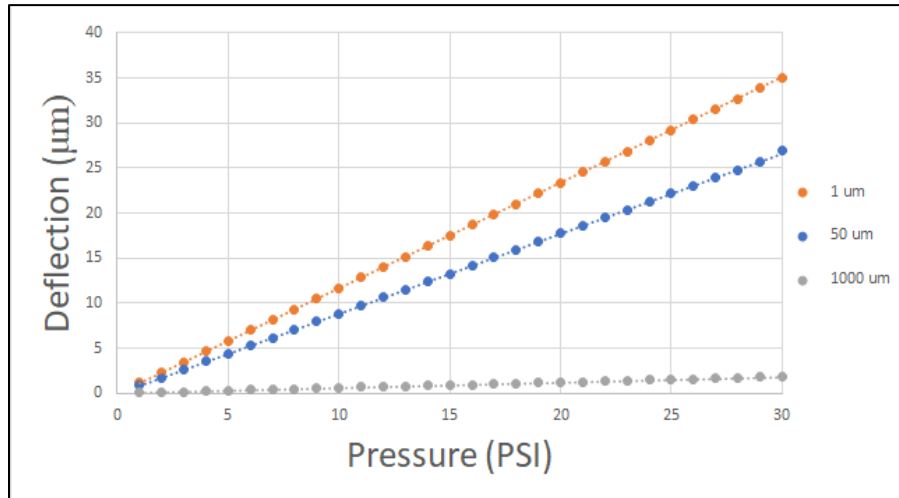

Figure 30. Graph comparing applied pressure to thin membrane deflection based on COMSOL simulation. The maximal deflection of the thin membrane is computed and graphed according to the pressure of the chamber. This was computed for models with membranes of varying thickness—1 µm, 50 µm, and 1000 µm.

These results gave valuable insight to our observations as we pressurized the microinjection region of our chip. Because the source of the behavior of the membrane was unclear, isolating the deflection without liquid ejection in a simulation allowed us to see the deflection of the membrane only as a product of pressurization with no confounding variables.

6.5.2. Needle movement

Due to the complexity of simulating the movement of the needle, this is an ongoing simulation project. Ideally, these results will give us greater insight as to how the pressurization of these chambers affects the behavior of the needle in the membrane.

6.5.3. Discrepancies between simulation and observation

The results of the simulation are not similar to observations of the system. Upon pressurizing the microinjection chamber, very little to no deflection is seen, in contrast to the approximately 20 micron deflection that is expected, this is likely because this simulation is coupled with a fluid ejection model, and the two systems have not been reconciled. Future work will need to create a system with both of these elements.

Chapter 7: Summary and Conclusion

7.1. Restatement of project objective

Our objective was to design a microfluidic device that could conduct on-chip immobilization and microinjection of *C. elegans* without the aid of any external elements. Our chip aimed to increase microinjection efficiency, consistency, and accessibility to researchers of all experience levels in order to advance genetics research and genetic engineering technology in *C. elegans*.

7.2. Project accomplishments

7.2.1. 100% microfluidic device

Our final device is completely microfluidic. There are no external components beyond those required to operate a microfluidic device. Our chip can be operated using multiple microscopes such as a basic dissecting scope (not just an inverted). The compatibility of our chip allows for future full automation via computer vision and programming. Overall, our chip is cheap, and easy to use regardless of your experience level.

7.2.2. Design novelty

Our chip novelty is the on-chip microinjection apparatus. Without cumbersome external elements, our chip is easier to setup and use. Additionally, our chip has the potential to unclog clogged needle tips. If the worm flow channel is pressurized, fluid is forced backward through the needle, expelling clogging debris. The ability to unclog needles saves researchers from wasting valuable time and reagents.

Another novel aspect of our design is its brief worm-immobilization time. Compared to other chips and methods, our design immobilizes worms for a fraction of the time, reducing unnecessary strain on the worm's body. Worms spend a maximum of 1 second immobilized before being allowed to float off the needle and into the channel again. By reducing the total

stress exerted on the worm, we increase the likelihood of their survival. This increases the number of successful injections and ensures that valuable worm strains are not wasted.

7.3. Future work

7.3.1. Complete characterization of novel, on-chip microinjector

The physical properties of the novel, on-chip microinjection apparatus is not yet fully understood. Currently, our design utilizes two integrated systems, (1) a physical deformation system, and (2) a fluid ejection system. This poses a challenging math and physics problem as the relationship between chamber pressurization is confounded with both membrane deflection and fluid ejection. We are currently conducting ejection rate experiments to characterize the needle tips. We are also exploring further COMSOL simulations to try to better understand the discrepancy between our COMSOL simulation results (see Chapter 6) and our failure to observe membrane deflection in our experiments.

In addition to the issue of the coupled deflection-ejection system, we need to fully characterize the effect of actuation of the control valve located directly above the microinjection chamber (see Figure 7, red valve below valve 2) on the angle of the needle. It is unclear how dramatically the valve actuation affects needle angle and whether it has the ability to fully stop needle fluid flow when actuated.

7.3.2. Injection of genetic construct

Currently, we have been injecting red food dye into the worms to better visualize the injection process. Moving forward, we will be injecting a clear solution containing our genetic construct. We will be injecting a plasmid (rol-6[su1006]) that confers a “roller” phenotype to the worms. This means that we will be able to determine transformation efficiency by scoring the number of “roller” worms generated by our injections.

7.3.3. Post-injection analysis

Finally, to evaluate the effectiveness of our chip as a tool for *C. elegans* microinjection, we will need to determine (1) transformation efficiency, (2) the rate at which worms survive the injection procedure, and (3), the effect of our injection technique on worm lifespan. All three of these statistics will be obtained once we start regularly injecting synchronized populations of young adult worms with our rol-6 plasmid.

7.4. Engineering standards

This project addresses multiple engineering concerns: ethics; health and safety; manufacturability; usability; science, technology, and society; economic; environmental impact; civic engagement; and sustainability. The ethics of this project will be examined throughout each subsequent engineering standard. For a more thorough and ethics-specific analysis, see Appendix E.

7.4.1. Health and safety

All users have a right to their own safety and a similar duty to maintain their own and the safety of others. Our product both introduces and mitigates risks in comparison to traditional microinjection. While mitigation of existing risks is beneficial to all, the introduction of some new risks may outweigh whatever mitigation is introduced. The danger that any of these risks pose is entirely based on user expertise and experience.

The majority of the new risks that we introduce are the result of the additional facilities and equipment that our project requires for fabrication (See Section 3.1). Our project calls for the use of chemicals that are known to be hazardous (toxic, flammable), and uses a machine that requires UV light. Exposure to chemicals can be mitigated by wearing proper protective equipment (PPE) and following lab safety protocols, and eyes can be protected from UV exposure. However, other exposed areas of

the skin (mouth, neck, etc.), cannot be protected from the UV light, and it is recommended that the user face away from the machine during exposure times.

Our product fabrication also requires that some microinjection equipment be used in untraditional ways. The micromanipulator and inverted microscope are used to break micron scale glass needle tips from traditional microinjection needles. While protocols have been created to diminish the risks and handling of these micron size needle fragments, always consult with the owner of the equipment before using it as our product requires. PPE should always be worn to avoid fragment contact with the skin, and eyewear is essential to avoid getting fragments in the user's eyes.

No injuries have occurred over the course of this project while completing any procedures. Despite the risks introduced, current safety protocols in most lab spaces should be sufficient to mitigate risks and potential harm. Overall, the biggest potential risk to a user's safety is introduced by the user alone if she chooses not to follow appropriate PPE guidelines and safety training.

Our product eliminates multiple dangerous elements required by traditional microinjection. It no longer requires the user to directly interact with glass with molten sections, and our product decreases the need for exposed flames in lab. Our product eliminates the requirement of mouth-pipetting to load genetic material into microinjection needles. While most of these genetic materials have little immediate risk to a user's health, mouth pipetting should always be avoided. Our product also reduces the probability that a user impales their hand on a needle when loading genetic material into a microinjection needle.

Traditional methods have higher hazard risk than our final solution. Our solution introduces new hazards with known safety procedures. Our

solution does not require that any used chemicals come into even remote contact with the mouth. Traditional microinjection also has a high probability of physical injury, via either puncture wounds or burns. It is hard to mitigate the probability of these risks, as they are necessarily introduced for the sake of traditional microinjection.

7.4.2. Manufacturability

Our product requires multiple facilities and a variety of equipment: research location determines feasibility of use. If one is already capable of conducting *C. elegans* microinjections, the individual would still require a significant amount of resources to be capable of using our product.

The microfluidics side of our product requires a cleanroom, a microfluidic laboratory, and lots of equipment (spin coaters, a mask aligner, volatile chemicals, etc.). The product also requires a microfluidic multiplexer, multiple air and vacuum sources, and the accompanying software to make the multiplexer work.

Santa Clara University is fortunate to already have all of these facilities and materials, no new equipment was purchased to make our device work. If a *C. elegans* researcher find themselves in a similar position, then our product will work for them. Current prototypes are capable of injecting over twelve worms per use, compared to three injections for traditional methods. Our chip also has the unique ability to unclog its needles, saving more genetic reagent in comparison to traditional methods. Finally, our product can be used under any microscope, freeing microinjection from the inverted microscope. Our product saves time, allowing for more injections, more experiments, and more research.

However, while other facilities and universities have access to the required spaces, many *C. elegans* researchers do not. This is a violation of fairness; our product can only be used in higher-end research settings. Deciding

reparations for this violation is difficult, the common-good approach would imply that those with access to our product have a duty to share their findings to those without access. In the *C. elegans* research community, people are much more forthcoming with their findings, but our product does not diminish the barrier between *C. elegans* researchers with access to higher-end facilities versus those with access to lower-end facilities. It is possible that our product could be commercially built, but then it would still require a microfluidic multiplexer and software to function, neither of which are cheap.

7.4.3. Usability

As mentioned in Section 1.2, microinjection is a linchpin to *C. elegans* genetics research. Assuming a researcher can access and use our product, she will find this is no longer the case: microinjections can be performed by anyone with our product, and they can be performed quickly. Hence, we anticipate more publications pertaining to *C. elegans* and microinjection, potentially to the chagrin of established microinjection researchers. Overall, though, our product long term benefits outweigh its immediate consequences.

Our product requires one person for complete fabrication. It does not require someone with a doctorate, but fabrication of the product relies on someone having basic knowledge about microfluidics. Hence, the knowledge required to complete microinjection is less severe, but may not be found in a traditional *C. elegans* research laboratory.

Our product requires two people to operate. Operation of this device is very difficult without two people, primarily due to the software that interacts with our chip. On a per capita basis, our product requires more than traditional methods; however, it also increases opportunities for a workforce of undergraduate research students looking for work in labs. Allowing undergraduates to participate in the research and assist in

operations would also afford the PI more time to examine topics that are less familiar to other students. In general, despite the increase in personnel, the project as a whole is more accessible to everyone; allowing for better division of labor and more rapid progress.

7.4.4. Science, technology, and society

Our product is designed to support research in the field of genetic engineering, particularly within *C. elegans*. *C. elegans* is studied due to the high amount of overlap between their genome and humans. Ultimately, researchers hope to apply their findings to humans. Genetic engineering in humans is a controversial topic: it holds the potential to cure many diseases, but at the most extreme of ends could result in the creation of “designer babies.” Our product has the potential to bring about either one of these ends - society and genetic engineers will have to choose which ones we achieve. In order to reach the most desirable of ends, it is essential that we continue to talk about genetic engineering, its potential impacts, and how we wish to use the technology. This is the best way to ensure that our product does not help realize an undesirable future.

7.4.5. Economic

The cost of our product is low. Based on raw materials alone, an individual chip costs no more than five dollars (PDMS, *C. elegans* maintenance supplies, etc.). It is difficult to account for the costs that our equipment incurs, though. We are fortunate in that no additional equipment needed to be purchased for our project. The most expensive of items (inverted microscope, mask aligner, micromanipulator, clean room) already existed on SCU’s campus. If we were to secure our own facilities, costs for our product would go up exponentially. Finally, as students, we do not charge for labor. In total, about ten hours are required to make a chip from scratch (no mold), if a mold is present, six hours are required (mold casting and needle embedding). Lots of this labor requires skilled

technicians and would drastically increase the cost of our chip. For our purposes, our chip is cheap - this may not be the case outside of SCU.

7.4.6. Environmental impact

Our product has two primary wastes: sharps and chemicals. Sharps are convenient enough to dispose of, our chemical waste is another story. All chemicals pertaining to mold fabrication (See Section 2.5) are hazardous (toxic, flammable), and require care to be disposed of properly. PDMS becomes far less toxic as it cures, eventually becoming biocompatible. However, chip fabrication wastes a lot of PDMS. While we have attempted to mitigate PDMS waste throughout our project (some is reused for the needle cutting procedure), there is still inevitable waste, which must be taken into consideration.

7.4.7. Civic engagement

There is potential for a patent in our product. Approval for a patent will need to be filed through the US patent office. In order to receive a patent, we will need to prove that our product does not infringe upon any other patents. Similarly, we will need to prove that our product is novel enough to warrant receiving its own patent.

7.4.8. Sustainability

Our product is more sustainable than traditional methods, though microfluidic chips are inherently disposable. Needles clog frequently in microinjection due to their small size, but our chip does allow them to be unclogged. Therefore, we can get needles to last longer than usual. Chips should not be used for multiple genetic constructs, as microinjection chambers are nearly impossible to wash out.

7.5. Team and management

For more detailed information related to our project, see Table 1 below for relevant contact information.

Table 1. Team member specialties and contact information.

	Name	Email	Discipline	Project Expertise
Team	Delaney Gray	drgray@scu.edu	Bioengineering	<i>C. elegans</i> , needle embedding, microfluidics/fabrication
	Alex Hadsell	ahadsell@scu.edu	Bioengineering	Microfluidics/fabrication, AutoCAD, stats
	Jessica Talamantes	jtalamantes@scu.edu	Bioengineering	COMSOL simulations, LeviCell
Advisor	Dr. Emre Araci	iaraci@scu.edu	Bioengineering	Microfluidics, microfabrication
Advisor	Dr. Leilani Miller	lmiller@scu.edu	Biology	<i>C. elegans</i> , manual microinjection

7.6. Budget

For general budget information, see Table 2 below. All funds were provided by the Santa Clara University School of Engineering. All supplies not listed were generously provided by Dr. Emre Araci (SCU Bioengineering Department) and Dr. Leilani Miller (SCU Biology Department).

Table 2. Project budget breakdown.

Category	Item	Number	Unit Cost (\$)	Total (\$)
Photolithography supplies	Silicon wafers (10 cm)	10 wafers	10.00	100.00
	SU-8 2050	1 (500 mL)	650.00	650.00
	SU-8 Developer	1 (4L)	172.90	172.89
	SPR	1 (500 mL)	700.00	700.00
	SPR Developer	1 (1 gallon)	48.75	48.75
Soft lithography supplies	PDMS	1 gallon	700.00	700.00
	TMCS	50 ml	120.00	120.00
<i>C. Elegans</i> supplies	Bactopectone	1 (500g)	133.57	133.57
	Agar	1 (500g)	181.98	181.98
	60 mm worm plates	1 case (500)	52.97	52.97
	Glass capillaries	1 box (500)	57.00	57.00
			Total cost:	\$2,917.16

7.7. Project timeline

Our project was broken down in four main phases which loosely corresponded to the four quarters we spent working on this project. We spent the Spring (2018) of junior year conducting background research on our project and formulating our initial microfluidic chip design. The following three quarters in our senior year were spent designing, manufacturing, and testing three different iterations of our chip design. For a general overview of our project timeline, see Table 3 below.

Table 3. Project timeline.

	Spring Quarter 2018			Fall Quarter 2018				Winter Quarter 2019			Spring Quarter 2019		
	Apr	May	Jun	Sep	Oct	Nov	Dec	Jan	Feb	Mar	Apr	May	Jun
Phase 1: Team formation and Project Selection													
Formation of senior design team	■												
Needs finding and background research	■	■	■										
Preliminary concept of microfluidic chip design		■	■										
AutoCAD for design iteration #1		■	■										
Ordered photomask for design iteration #1			■										
Phase 2: Chip Iteration #1 Design and Prototyping													
Microfabrication of chip iteration #1				■	■								
Flow testing of chip iteration #1				■	■	■							
Worm testing of chip iteration #1					■	■	■						
Design review and modification						■	■						
BIOE 194: Conceptual Design Review (CDR) presentation							■						
Phase 3: Chip Iteration #2 Design and Prototyping													
AutoCAD for design iteration #2								■					
Ordered photomask for design iteration #2								■					
Microfabrication of chip iteration #2									■	■			
Flow testing of chip iteration #2									■	■	■		
Worm testing of chip iteration #2									■	■	■		
Preliminary design of microfluidic microinjector										■	■		
Design review and modification										■	■		
Phase 4: Final Chip Iteration #3 Design and Prototyping													
Creation of specialty mold from photomask #2											■		
Microfabrication of chip iteration #3											■	■	
Flow testing of chip iteration #3											■	■	■
Worm testing of chip iteration #3											■	■	■
Successful microinjection!											■	■	■
Senior Design Conference											■	■	■
Senior design thesis							■	■	■	■	■	■	■

Bibliography

1. Corsi, Ann K., et al. "A Transparent Window into Biology: A Primer on *Caenorhabditis Elegans*." *Genetics*, Genetics, 1 June 2015, www.genetics.org/content/200/2/387.
2. Evans, Thomas C. "Transformation and Microinjection*." *WormBook* Header Image, 6 Apr. 2006, www.wormbook.org/chapters/www_transformationmicroinjection/transformation_microinjection.html.
3. Rieckher, Matthias, and Nektarios Tavernarakis. "Caenorhabditis Elegans Microinjection." *Bio-Protocol*, U.S. National Library of Medicine, 5 Oct. 2017, www.ncbi.nlm.nih.gov/pmc/articles/PMC5734614/.
4. Evans et al, (2006).
5. San-Miguel, Adriana, and Hang Lu. "Microfluidics as a Tool for *C. Elegans* Research*." *WormBook* Header Image, 24 Sept. 2013, www.wormbook.org/chapters/www_microfluidics/microfluidics.html.
6. Ardeshiri, Ramtin, et al. "A hybrid microfluidic device for on-demand orientation and multidirectional imaging of *C. elegans* organs and neurons." *Biomicrofluidics* 10.6 (2016): 064111.
7. Ardeshiri et al, (2016).
8. Zhao, Xingfu, et al. "Microfluidic Chip-Based *C. Elegans* Microinjection System for Investigating Cell–Cell Communication in Vivo." *Biosensors and Bioelectronics*, Elsevier, 22 June 2013, www.sciencedirect.com/science/article/pii/S0956566313004211
9. Song, Pengfei, et al. "A Microfluidic Device for Automated, High-Speed Microinjection of *Caenorhabditis Elegans*." *Biomicrofluidics*, AIP Publishing LLC, 26 Feb. 2016, www.ncbi.nlm.nih.gov/pubmed/26958099.
10. Song et al, (2016).
11. Song et al, (2016).

12. San-Miguel et al, (2013).
13. Evans et al, (2006).
14. Evans et al, (2006).
15. Wolkow, C. A., and D. H. Hall. "Introduction to the dauer larva, Overview."
WormAtlas, 2015.
16. Stiernagle, Theresa. "Maintenance of *C. elegans*. WormBook. The *C. elegans*
research community." *WormBook* (2006).
17. <https://cgc.umn.edu/strain/N2>
18. Ardeshiri et al, (2016).
19. Evans et al, (2006).
20. <https://cgc.umn.edu/>
21. Corsi et al, (2015).
22. <http://www.tritechresearch.com/petri.html>
23. <http://www.tritechresearch.com/pourboy.html>
24. https://catalog.hardydiagnostics.com/cp_prod/product/c5001-agar-bacteriological-grade-criterion-dehydrated-culture-media-500gm-wide-mouth-bottle-by-hardy-diagnostics-dehydrated-media---criterion
25. <https://us.vwr.com/store/product/16078369/bd-bacto-peptone-bd-biosciences>
26. Stiernagle et al, (2006).

Appendices

Appendix A: Manual microinjection procedure

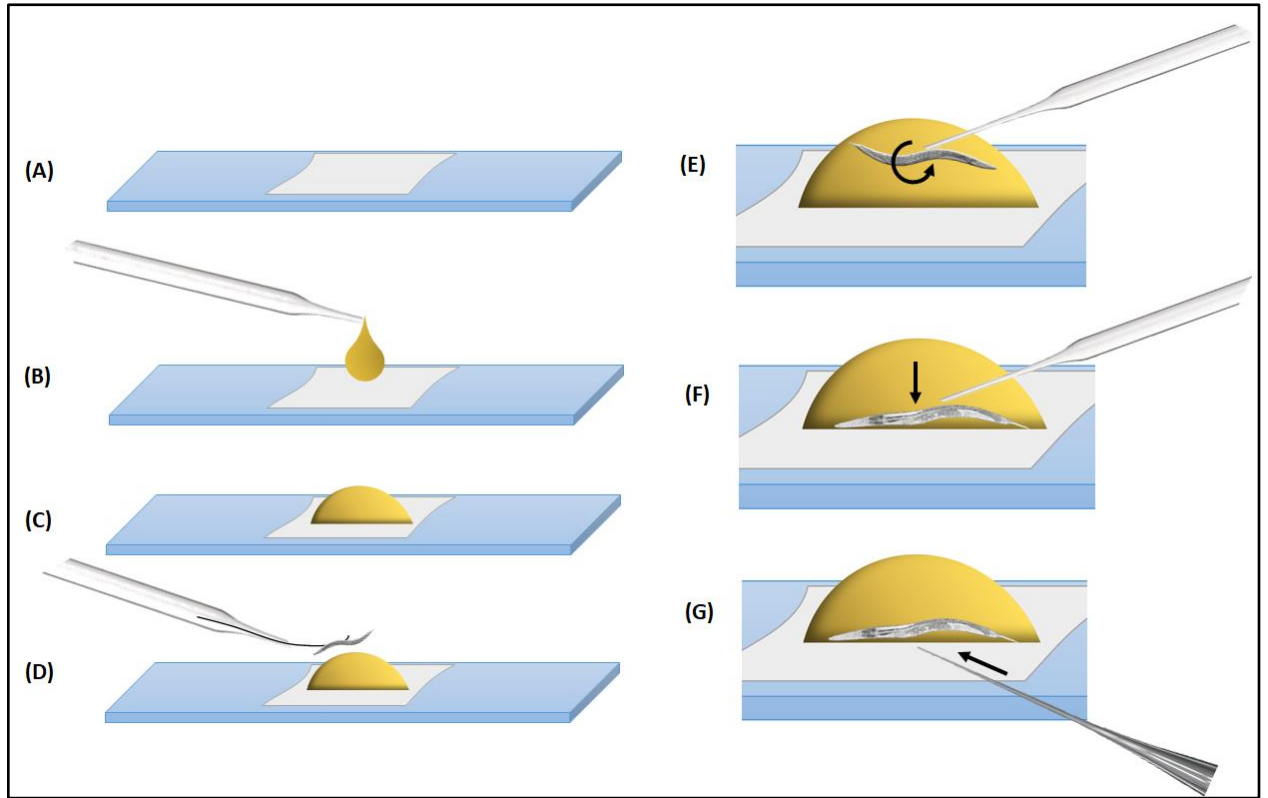

Figure 31. Schematic of manual microinjection procedure. (A) Glass slide (light blue) with agarose injection pad (gray). (B) Drop of halocarbon oil (yellow) placed on injection pad to act as temporary buffer between worm and sticky injection pad. (C-D) Worm manually placed in oil droplet for maneuvering. (E) Worm is manually oriented using a modified (heat-blunted) glass Pasteur pipette. Worm is rolled until gonad is in proper position for a successful injection. (G) Once aligned, worm is pressed down through the oil to contact the adhesive injection pad. (F) With worm securely adhered, a microinjection needle can be brought alongside the worm and the worm is injected. See Evans et al (2006) for detailed instructions regarding manual microinjection¹.

¹ Evans et al. "Transformation and microinjection." *WormBook*, (2006).

Appendix B: Ordering and maintaining *C. elegans* N2 strain

C. elegans strains can be ordered from the Caenorhabditis Genetics Center². The *C. elegans* wild isolate N2 strain was utilized for all chip experiments. *C. elegans* animals are hermaphroditic (although males arise at a rate of < 0.2%) and can self-fertilize a brood size of about 350³. Their generation time is temperature-dependent; At 23°C, their generation time is about 3 days from egg to egg-laying adult. At 20°C, their generation time is about 4 days. At 15°C, their generation time is about 7 days. The N2, wild type worms used in these experiments were maintained at 23°C and allowed to self-fertilize.

Appendix C: Preparation of Nematode Growth Medium (NGM) agar plates

Materials

- 60 mm non-vented sharp edge petri dishes⁴
- PourBoy Sterile Media Dispenser⁵
- Magnetic stir bar
- Magnetic stir plate
- 2L Erlenmeyer flask
- Aluminum Foil
- Autoclave tape
- Deionized water (Barnstead 10 megaohm)
- NaCl salt
- Bacteriological Grade Agar⁶
- BD Bacto™ Peptone⁷
- 5 mg/ml cholesterol in ethanol
- 1 M CaCl₂
- 1 M KPO₄
- 1M MgSO₄

² <https://cgc.umn.edu/>

³ Corsi et al. "A transparent window into biology: a primer on *Caenorhabditis elegans*." *Genetics*, (2015).

⁴ <http://www.tritechresearch.com/petri.html>

⁵ <http://www.tritechresearch.com/pourboy.html>

⁶ https://catalog.hardydiagnostics.com/cp_prod/product/c5001-agar-bacteriological-grade-criterion-dehydrated-culture-media-500gm-wide-mouth-bottle-by-hardy-diagnostics-dehydrated-media---criterion

⁷ <https://us.vwr.com/store/product/16078369/bd-bacto-peptone-bd-biosciences>

- Cholesterol (5mg/ml)

Methods

- In the 2L Erlenmeyer flask combine:
 - 1450 ml diH₂O (Barnstead 10 megaohm)
 - 30g Bacteriological Grade Agar
 - 3.75g BD Bacto™ Peptone
 - 4.5g NaCl salt
- Mix with magnetic stir bar.
- Cover mouth of flask with foil, mark with autoclave tape, autoclave on liquid cycle (20 minutes).
- Autoclave PourBoy tubing on gravity cycle (10 minutes).
- Place media flask into 65 centigrade water bath and allow to cool for 1 hour.
- While cooling, prepare plate pouring workspace:
 - Clean counters with lysol.
 - 1 flask of media should fill 6-7 sleeves of petri dishes (20 per sleeve). Set up petri dishes in stacks of 5.
 - Set up PourBoy sterile media dispenser and spray ethanol on the bracket area to sterilize.
 - Set PourBoy to dispense 11-12ml of media per plate.
- Once cooled, add the following salts in order to the autoclaved media:
 - 1.5ml 1 M CaCl₂
 - 1.5ml 1M MgSO₄
 - 37.5ml 1 M KPO₄
 - 1ml Cholesterol (5mg/ml)
- Pouring NGM agar plates:
 - Run one bottle of 50/50 autoclaved diH₂O followed by one bottle of autoclaved diH₂O through the pump system.
 - Carefully place tube into media flask and pump until air bubbles clear and NGM agar is flowing smoothly.
 - Pour 11-12 ml of NGM agar into each plate (one pump per plate).
 - Once done, immediately rinse 2L flask and PourBoy tubing with hot water to prevent solidification of agar inside.
- Allow NGM agar plates to dry for 3-4 days before spreading.

- Spreading NGM agar plates with *E. coli* OP50 bacteria food source
- *C. elegans* animals are generally maintained monoxenically with an *E. coli* (OP50) bacterial food source. *E. coli* OP50 is an uracil auxotroph that is growth-restricted by the lack of uracil found in NGM agar plate media⁸. It is spread manually on NGM agar plates and grown as a restricted lawn.

Appendix D: Magnetic density-based sorting of *C. elegans*

Introduction

LevitasBio, a local bioengineering company in the Bay Area, created a “Magnetic Levitation Technology,” and implemented this novel technology into their device, LeviCell. LeviCell consists of two permanent magnets on either side of a flow channel. Previously, this device has been used for cell analysis and sorting. When cells flow through the channel, the magnet technology generates separation, provoking the cells to levitate based on cell type. This observable separation is dependent primarily on cell density and is supplemented by the magnetic properties of the cells. Further separation occurs as the sample flows into a bifurcated tube, allowing for collection of the separated samples. The device allows for flow control so, in addition to controlling flow rate, the sample in the channel can be held for levitation analysis.

One of our senior design advisors, Dr. Emre Araci, had been in contact with LevitasBio about installing LeviCell on Santa Clara University campus and potential research opportunities with the technology. With the novel separation technology, we were curious of the potential application in *C. elegans* sorting—whether that is sorting worms of different sizes, sorting live worms versus dead worms, or some other type of sorting—, rather than cell sorting.

⁸ Stiernagle et al. “Maintenance of *C. elegans*.” *WormBook*, (2006).

Detailed design description

With no prior *C. elegans* exploration in LeviCell, we approached the technology from a discovery-based standpoint. We were interested in whether the levitation technology would affect *C. elegans* worms.

LeviCell viability

The LeviCell technology does not rely solely on the permanent magnets surrounding the flow channel. Instead, the sample of interest must be suspended in a levitation reagent. So, we decided to first test whether the *C. elegans* worms tolerate the reagent. We created two solutions, the first using DI water. DI water is commonly used as a buffer solution when using LeviCell. However, DI water is known to aggravate *C. elegans* worms. So, we made the other solution using the known worm-compatible buffer, M9. Diluting the levitation reagent to a 1X concentration, we suspended the *C. elegans* worms and observed the worms over increments of a two-hour time period to assess viability.

Preliminary Tests

Once we proved that the Levitas levitation reagent was not toxic for *C. elegans*, we decided to observe how the LeviCell device affected the worms. A few plates of live *C. elegans* were washed using the M9 buffer, and this worm solution was then combined with the levitation reagent to create a 1X concentration just as in the viability test. Then, after properly preparing and priming the LeviCell device, the sample of worms was flowed through the device.

Control Tests

After confirming that the LeviCell device affects *C. elegans* worms, the question became whether there were noticeable levitation differences between any variation of the worms. For this reason, the worm samples for the control tests were more precise. We prepared three worm samples in a

1X concentration solution of levitation reagent and M9 buffer. The first sample was a live sample, similar to those from the preliminary tests. The second sample consisted of anesthetized worms. The worms were anesthetized using the same methods described in Chapter 3 of this paper. For the third and final sample, the worms were killed in bleach. This process followed the same bleaching process used in the worm synchronization described in Chapter 3. Then, after preparing and priming the LeviCell device, each sample was again flowed through the device.

Expected Results

While cells are relatively small and immobile, adult *C. elegans* used for genetics research are approximately 1 millimeter in length and 40 μm at their largest diameter—significantly larger than individual cells. In addition to their size, *C. elegans* animals are extremely mobile and tend to swim against the current of the flow. Due to these characteristic differences, we were not sure what to expect when introducing *C. elegans* to LeviCell. We were expecting the magnetic levitation technology to affect the *C. elegans*, but we were not sure to what extent. Additionally, the densities of *C. elegans* worms are unknown, and thus, there was a potential for variations in levitation height resulting from any number of variables. We considered age as a potential factor. Whether or not the worms were alive, dead, or anesthetized was another potential factor. Ultimately, however, we did not anticipate significant levitation height differences as there does not appear to be a significant difference in worm densities considering the controlled variables.

- **Materials and Methods**

- **Materials**

- Maintained *C. elegans* plates
- M9 Buffer
- Materials for anesthetizing and bleaching the worms
- 20X Levitation Reagent

- **Preparing the Live Sample**
 - Wash the worm plate using 1 mL M9.
 - Transfer 50 μ L 20X Levitation reagent into a clean, labeled 1.5 mL centrifuge tube.
 - Transfer all the M9 solution containing the *C. elegans* worms into the same tube and add M9 until the total volume is 1 mL (some M9 was lost while washing the plate).

- **Preparing the Anesthetized Sample**
 - Follow the method for anesthetizing the *C. elegans*
 - Transfer 50 μ L 20X Levitation reagent into a clean, labeled 1.5 mL centrifuge tube.
 - Transfer the *C. elegans* solution to the same tube.
 - Add M9 until the total volume is 1 mL.

- **Preparing the Dead Sample**
 - Follow the method for synchronizing the worms.
 - Resuspend the dead worms in 0.5 mL M9.
 - Transfer 50 μ L 20X Levitation reagent into a clean, labeled 1.5 mL centrifuge tube.
 - Transfer the resuspended *C. elegans* to the same tube.
 - Add M9 until the total volume is 1 mL.

Results

The initial viability tests revealed that the levitation buffer is not toxic to *C. elegans*. Additionally, those initial tests confirmed the well-established knowledge that a *C. elegans* prefers M9 buffer to water.

The preliminary attempt to insert a live, unanesthetized sample into the LeviCell device showed that the magnetic levitation technology does, in fact, affect *C. elegans*. As shown in Figure 32, the *C. elegans* animals are seen levitating in a confined band within the flow channel of the LeviCell device. With this preliminary test, there was no clear pattern to the outliers. There were occasional

eggs flowing outside the band, and there were occasional *C. elegans*, either developing or developed, that were not constrained to the band pictured in the figure. However, the live *C. elegans* were seen beyond the band more frequently than the eggs.



Figure 32. Live, unanesthetized worms levitating in LeviCell instrument. The agar plate washed for this experiment was not synchronized, thus providing the observable age variety from eggs to adults.

The control tests featured the three sample environments—live, unanesthetized *C. elegans*, live, anesthetized *C. elegans*, and dead worms. The live, unanesthetized sample did not deviate from the preliminary test. The live, anesthetized sample, seen in Figure 33, showed a similar result. Eggs and anesthetized worms alike flowed through the channel in a relatively confined band. The outliers appeared less frequently compared to the unanesthetized sample, yet, there were still occasional outliers. Notably, the live, anesthetized *C. elegans* sample band appeared to levitate at a lower channel height.

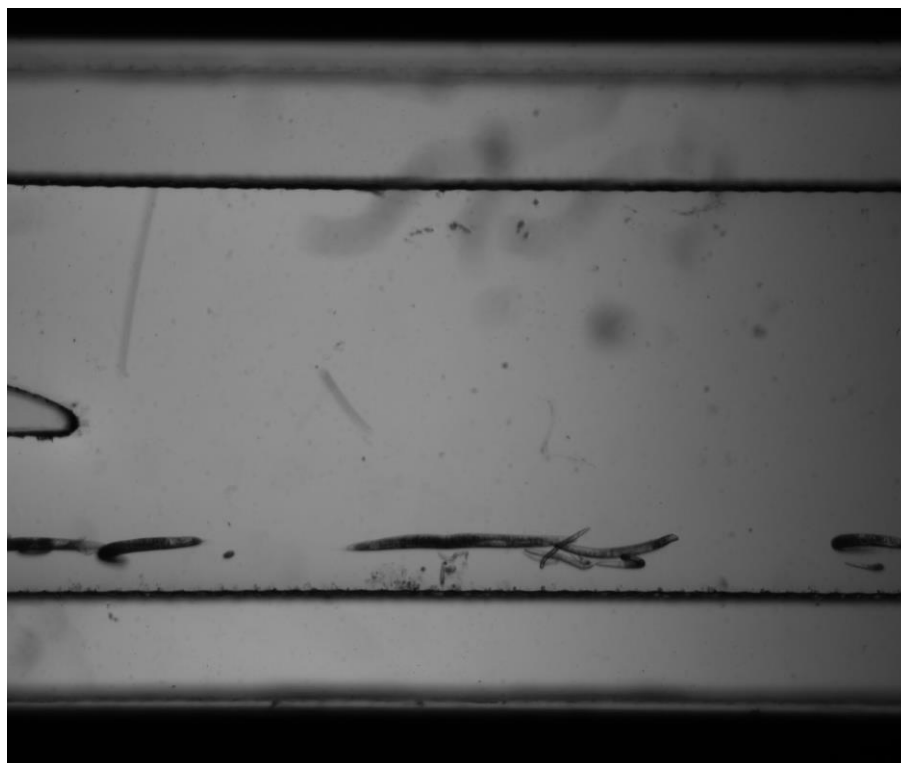

Figure 33. Live, anesthetized worms levitating in LeviCell instrument.

Not surprisingly, the final test, featuring the sample of dead *C. elegans* showed minimal results. Due to the rapid decay of the *C. elegans*' organism following a bleach treatment, the sample did not contain enough matter for observation.

Discussion

Because there is minimal research relating LeviCell use and *C. elegans*, there are many potential avenues for future research. It is known that varying the levitation reagent can increase the separation between matters of different densities. Additionally, it would be interesting to test the effect of injection on the levitation height, and the crossover of the magnetic levitation technology and *C. elegans* needs to be explored. Therefore, because we have proven that the technology affects the organism, there is enormous capacity for future research.

Appendix E: Ethical Analysis of Microfluidic Chip for Microinjection of *C. Elegans*

1. Introduction

For our Senior Design Project, we designed a microfluidic device to perform microinjection of genetic material into *C. elegans*, an invaluable model organism. Our project objective was to increase microinjection efficiency, consistency, and accessibility to researchers of all experience levels in order to advance genetics research and genetic engineering technology in *C. elegans*.

1.1 *Caenorhabditis elegans* is an invaluable model organism

C. elegans is a terrestrial soil nematode that has served as a model system for human disease and genetics research since the 1970's. The worm is an invaluable model organism for the study of molecular and cellular processes in humans due to their small size, rapid generation time, easy cultivation, and invariant cell number. Additionally, 40% of genes known to be associated with human disease have clear orthologs in the *C. elegans* genome.

1.2 Limitations of traditional microinjection methods

In *C. elegans* genetics research, microinjection of genetic material into the worms is critical. Although an established technique, manual microinjection is tedious, error-prone, low-throughput, and requires an expert researcher. From start to finish, the process takes about four hours and can result in many failed injections even with an experienced researcher. As a result, microinjection has a bottleneck effect on genetics research in *C. elegans*, greatly restricting the field.

2. Primary Ethical Considerations of Project

Our project has three primary ethical concerns all related to accessibility: whether our solution is indeed more accessible than traditional microinjections, how we might be negatively impacting the researchers that can already perform microinjections, how increased accessibility may result in abuse of our product and the science around it, and the product's overall safety.

2.1 Accessibility of our solution

If our final solution is more complicated than existing technologies, then it's worth must be called into question. If our project replaces the need for someone with a doctorate in genetics with someone with a doctorate in microfluidics, then we have not made microinjections more accessible.

2.2 Consequences of making research more accessible

If our product is accessible to a researcher, they will find that *C. elegans* genetics research is also more accessible. Our project may deprive some *C. elegans* researchers that are capable of microinjection from future papers. In academia, success is frequently measured by an author's publications. Current researchers may find that papers they planned on researching will now be addressed sooner by other labs.

2.3 Potential abuse of our product as a result of accessibility

Along with increased accessibility will come increased use. As with any product, it is essential to consider how this product could be misused, particularly in the laboratory setting.

2.5 Safety

It is important to consider all safety concerns that our product contains. Our product uses a variety of facilities and chemicals that are hazardous to one's health. Some portions of the project also contain physical hazards.

2.4 The ethics of genetic engineering

The field of genetic engineering is full of ethical questions that merit entire essays, these questions are not the focus of our ethical discussion. While genetic engineering is surely a consideration of our project, we intend to focus on the accessibility of a technology primarily and acknowledge that many discussions must continue to be had about the ethics of genetic engineering in general. Failure

to consider the long-term consequences of our technology is of course problematic, but for brevity and to avoid the sometimes-infinite consequences of our decisions, this discussion must be omitted from this paper.

3. Is our product more accessible?

Currently, based on the resources that Santa Clara University can provide, our product does make microinjection more accessible. However, increased accessibility and usage allows for potential misuse. Similarly, our product comes with multiple tradeoffs, revealing that a researcher's location impacts accessibility more than anything else.

3.1 Required facilities and equipment

Our product requires multiple facilities and a variety of equipment: research location determines feasibility of use. If one already can conduct *C. elegans* microinjections, the individual would still require a significant amount of resources to be capable of using our product.

The microfluidics side of our product requires a cleanroom, and lots of equipment to accompany it (spin coaters, a mask aligner, volatile chemicals, etc.). The product also requires a microfluidic multiplexer, multiple air and vacuum sources, and the accompanying software to make the multiplexer work.

Santa Clara University is fortunate to already have all of these facilities and materials, no new equipment has needed to be purchased to make our device work. If a *C. elegans* researcher find themselves in a similar position, then this product will work for them. Current prototypes are capable of injecting over twelve worms per use, compared to three for traditional methods. Our chip also has the unique ability to unclog its needles, saving more genetic reagent in comparison to traditional methods. Finally, our product can be used under any microscope, freeing microinjection from the inverted microscope. Our product save time, allowing for more injections, more experiments, and more research.

However, while other facilities and universities have access to the required spaces, many *C. elegans* researchers do not. This is a violation of fairness; our product can only be used in higher-end research settings. Deciding reparations for this violation is difficult, the common-good approach would imply that those with access to our product have a duty to share their findings to those without access. In the *C. elegans* research community, people are much more forthcoming with their findings, but our product does not diminish the barrier between *C. elegans* researchers with access to higher end facilities versus those with access to lower end facilities.

3.2 Required personnel

Our product requires one person for complete fabrication. It does not require someone with a doctorate, but fabrication of the product relies on someone having basic knowledge of microfluidics. Hence, the knowledge required to complete microinjection is less severe.

Our product requires two people to operate. Operation of this device is very difficult without two people, primarily due to the software that interacts with this chip. On a per capita basis, our product requires more than traditional methods; however, it also increases opportunities for a workforce of undergraduate research students looking for work in labs. Allowing undergraduates to participate in the research and assist in operations would also afford the PI more time to examine topics that are less familiar to other students. In general, despite the increase in personnel, the project as a whole is more accessible to everyone; allowing for better division of labor and more rapid progress.

3.3 People with unsteady hands

Compared to traditional methods, our product is easier to use for people with unsteady hands. Operation of the chip requires basic microscopy skills and the ability to use a computer mouse to interact with the microfluidic software. Traditional microinjection requires aligning objects on the micron scale and then

lightly tapping on the back of a needle to perform microinjection. Twitchy motions on the micromanipulator will prevent alignment of the needle with the worm's body, too hard of a tap may result in the development of sepsis in a worm.

4. Impact of more accessible research

As mentioned in Section 1.2, microinjection is a major rate limiting step for *C. elegans* genetics research. Assuming a researcher can access and use our product, they will find this is no longer then case: microinjections can be performed by anyone, and they can be performed quickly. Hence pros and cons must be weighed, particularly as it pertains to the ensuing publications. Overall, our product long term benefits outweigh its immediate consequences.

4.1 Increased competition

A person capable of performing microinjection already will find more competition in a field she was previously isolated in. Immediately, this will have a negative impact to said researcher. Papers and topics that the researcher had “stored,” awaiting until the researcher had time to address them, may sooner be addressed by other researchers. This will result in the researcher capable of microinjection losing a potential paper, while the researchers with new access to microinjection will gain a paper.

However, this paper would be going from someone with a PhD's worth of experience to someone with potentially much less experience. Initial publications are crucial to an early researcher's career, but publishable topics are hard to come by. Thus, a publication from our product could help someone with a master's or bachelor's degree more than someone with a doctorate. While the person with the doctorate would surely benefit from a publication, she would only be adding to a presumably impressive resume. Therefore, increased competition as a result of our product may help lower tiers of researchers and allow papers to have more impact on a person's career.

4.2 Increased field advancement

The doctor that lost a paper to competition can still benefit from our product: more genetics research in *C. elegans* will be conducted. The fields of biology and bioengineering benefit from the idea that research ultimately asks more questions than it answers. For every newfound understanding of *C. elegans* genetics as a result of our product, more questions can be asked, and the understanding of the model organism increases. Hence, one initial paper lost might be multiple papers gained. In general, as our understanding of *C. elegans* genetics increases, so too will the public's ability to use this knowledge.

5. Acceptable Use of our Product

As with all products, the usage of our product in a lab requires ethical considerations. The usage of the product will vary by experience level, and it is essential to recall that all use impacts the health of living animals. The user is strongly encouraged to consult the Biomedical Engineering Society's (BMES) Code of Ethics prior to using our product.

5.1 Use by an experienced doctor

A primary investigator with experience in microinjection that chooses to use our product may find the product is more time consuming to use initially. Both the PI and any students involved will need some familiarity with microfluidics. However, such education would serve to further the education of everyone. Education would also prevent any research assistants from being used as mere operators of a product they do not understand. Usage without teaching stands in direct conflict with a biomedical engineer's obligation "to train biomedical engineering students in proper professional conduct" according to the BMES Code of Ethics.

5.2 Use by a graduate or undergraduate

Our product increases the genetic engineering accessibility to graduates and undergraduates; it makes room for people with less experience in the field. There

are consequences to this reduced knowledge, though, such as sympathy for any *C. elegans* animals used in this product may be less for a graduate or undergraduate in comparison to someone with a doctorate. This lack of sympathy is the result of presumably less interaction with the animals and may result in mistreatment of the animals (See Section 5.3).

5.3 Animal rights

Our chip can inject more worms per unit of time, and thus it is also capable of hurting more worms per unit of time. Though *C. elegans* populations are easy to maintain, biomedical engineers “[respect] the rights of [...] animal subjects” per the BMES Code of Ethics. Although the animals are easy to raise, they have a universal right to not be recklessly hurt and killed. Users of our product have a duty to uphold this right in the course of their research.

Our product does kill more animals per unit of time, but the procedure that it conducts kills a smaller proportion of animals in comparison to traditional methods. The success rate of microinjections is higher, but the user may decide that the overall losses the product causes are unacceptable.

6. Product Safety

All users have a right to their own safety and a similar duty to maintain their own and the safety of others. Our product both introduces and mitigates risks in comparison to traditional microinjection. While mitigation of existing risks is beneficial to all, the introduction of some new risks may outweigh whatever mitigation is introduced. The danger that any of these risks pose is entirely based on user expertise and experience.

6.1 Risks introduced

The majority of the new risks that we introduce are the result of the additional facilities and equipment that our project requires for fabrication (See Section 3.1). Our project calls for the use of chemicals that are known to be hazardous (toxic, flammable), and uses a machine that requires UV light. Exposure to chemicals

can be mitigated by wearing proper protective equipment (PPE) and following lab safety protocols, and eyes can be protected from UV exposure. However, other exposed areas of the skin (mouth, neck, etc.), cannot be protected from the UV light, and it is recommended that the user face away from the machine during exposure times.

Our product fabrication also requires that some microinjection equipment be used in untraditional ways. The micromanipulator and inverted microscope are used to break micron scale needle tips from traditional microinjection needles. While protocols have been created to mitigate the risks and handling of these micron size needle fragments, always consult with the owner of the equipment before using it as our product directs. PPE should always be worn to avoid fragment contact with the skin, and eyewear is essential to avoid getting fragments in the user's eyes.

No injuries have occurred over the course of this project while completing any procedures. Despite the risks introduced, current safety protocols in most lab spaces should be enough to mitigate risks and potential harm.

6.2 Risks mitigated

Our product eliminates multiple dangerous elements required by traditional microinjection. It no longer requires the user to directly glass with molten sections and decreases the need for exposed flames in lab. Our product eliminates the requirement of mouth-pipetting to load genetic material into microinjection needles. While most of these genetic materials have little immediate risk to a user's health, mouth pipetting should always be avoided. Our product also diminishes the probability that a user impales their hand on a needle when loading genetic material into a microinjection needle.

6.3 Overall

Traditional methods have higher hazard risk than our final solution. Our solution introduces new hazards with known safety procedures. Our solution does not

require that any used chemicals come into even remote contact with the mouth. Traditional microinjection also has a high probability of physical injury, via either puncture wounds or burns. It is hard to mitigate the probability of these risks, as they are necessarily introduced for the sake of traditional microinjection.