

University of Northern Iowa
UNI ScholarWorks

Electronic Theses and Dissertations

Graduate College

2017

Smartphone based ubiquitous sensing platform leveraging audio jack for power and communication

Ranjana Joshi
University of Northern Iowa

Copyright ©2017 Ranjana Joshi

Follow this and additional works at: <https://scholarworks.uni.edu/etd>

 Part of the [Electrical and Computer Engineering Commons](#)

Let us know how access to this document benefits you

Recommended Citation

Joshi, Ranjana, "Smartphone based ubiquitous sensing platform leveraging audio jack for power and communication" (2017).
Electronic Theses and Dissertations. 474.
<https://scholarworks.uni.edu/etd/474>

This Open Access Dissertation is brought to you for free and open access by the Graduate College at UNI ScholarWorks. It has been accepted for inclusion in Electronic Theses and Dissertations by an authorized administrator of UNI ScholarWorks. For more information, please contact scholarworks@uni.edu.

Copyright by
RANJANA JOSHI
2017
All Rights Reserved

SMARTPHONE BASED UBIQUITOUS SENSING PLATFORM LEVERAGING
AUDIO JACK FOR POWER AND COMMUNICATION

An Abstract of a Dissertation
Submitted
in Partial Fulfillment
of the Requirements for the Degree
Doctor of Industrial Technology

Approved:

Dr. Hong Nie, Committee Chair

Dr. Patrick Pease
Interim Dean of the Graduate College

Ranjana Joshi
University of Northern Iowa
December, 2017

ABSTRACT

With the popularization of smartphones, various smartphone centric ubiquitous sensing applications, which use a smartphone in conjunction with external sensors for data acquisition, processing, display, communication, and storage, have emerged. Because smartphones do not have a universal data interfaces, many ubiquitous sensing applications use the earphone and the microphone channels of the 3.5mm audio interface for data communications so that they can work with various types of smartphones. The earphone channels of the 3.5mm audio interface can only send AC signal out of a smartphone, hence DC power needs to be harvested from the earphone channels.

In this research, based on frequency shift keying (FSK) modulation scheme, we have proposed a joint power harvesting and communication technology that can simultaneously harvest power and transfer data using the same earphone channels. The joint power harvesting and communication technology is demonstrated with a prototype system, which can power an external microcontroller and sensors through the 3.5mm audio interface of a smartphone, display sensor measurement results on a smartphone, and control the outputs of the microcontroller from a smartphone. The newly proposed smartphone sensing platform is expected to harvest double or more power from both earphone channels in comparison to single channel harvesting designs and hence has the potential to support more smartphone powered sensing applications.

Furthermore, the sensing platform is expected to support a reliable communication with much higher data rate from a smartphone to external sensors than existing designs.

SMARTPHONE BASED UBIQUITOUS SENSING PLATFORM LEVERAGING
AUDIO JACK FOR POWER AND COMMUNICATION

A Dissertation

Submitted

in Partial Fulfillment

of the Requirements for the Degree

Doctor of Industrial Technology

Approved:

Dr. Hong Nie, Committee Chair

Dr. Jin Zhu, Co-Chair

Dr. Nageswara Rao Posinasetti, Committee Member

Dr. Mark Ecker, Committee Member

Dr. Karthik Iyer, Committee Member

Ranjana Joshi

University of Northern Iowa

December, 2017

ACKNOWLEDGEMENT

I have spent nearly 5 years completing my education at the University of Northern Iowa and I have many people to thank for their support and guidance. It is my great pleasure to acknowledge people who have given me guidance, help and encouragement. This dissertation would not have been possible without the financial support from the Department of Technology and the head of the department, professors and staff who always work hard to support as many students as they can.

While writing this acknowledgement, I am thinking of the very first person I met during my education, my co-advisor and one of my committee members, Dr. Jin Zhu. At the beginning of my studies at UNI, she offered me a research project which not only exposed me to a new work culture, but also helped me gain more confidence as a researcher. Since then, she has always closely monitored my research and projects at UNI. I would like to take this opportunity to thank her for being a great support and mentor.

Each of the members of my Dissertation Committee has provided me with extensive personal and professional guidance and taught me a great deal about both scientific research and life in general.

I would especially like to thank Dr. Hong Nie, the chairman of my committee. As my teacher and mentor, he has taught me more than I can ever give him credit for. He has always been a tremendous support in providing resources for the success of this research. He is professional and, an excellent researcher who is always excited about his work and

helps others have the joy of thinking out of the box. I would like to thank him for his valuable time and effort towards my dissertation and my career.

I would like to thank my other committee members Dr. Rao, Dr. Karthik Iyer and Dr. Mark Ecker for closely reviewing my progress and helping me finish my dissertation. I have learned a lot while working with each of you and because you are not closely related to my field, you raised important questions which I would have overlooked. Thanks for your efforts and valuable input in completion of this dissertation.

I am especially indebted to Dr. Mohammed Fahmy as my professor. He was very motivating and the best critic I have ever met. The writing and presentation for his classes prepared me well to participate and excel in college and international conferences.

I owe special thanks to Dr. Julie Zhang for being the key motivator to my participation in the graduate symposium where I invested much time in studying and presenting the related work of my research.

The research and writing related courses I took from Dr. Salim and Dr. VarzaVand were extremely helpful for my research. They showed excitement in my work and shared their ideas, suggestions, and experience, which further helped me to refine my research study.

I also would like to thank the head of the department Dr. Lisa Riddle for her flexibility and effort in guiding me through various situations and her understanding of the difficulty of being both a doctoral student and a part time student employee in John Deere.

My deep appreciation goes out to Ziyang Li, my research team member for his invaluable contribution towards my PhD. There are other non-technical aspects of finishing this work and I would like to sincerely thank the staff of the Department of Technology Vickie Turner and Susan Quam for their immense support in keeping the semester smooth for students.

Nobody has been more important to me in the pursuit of this project than the members of my family. I would express my gratitude to my parents, my parents-in-law, my host family and my brother, whose support and constant encouragement helped me through the hard times of this program. My deepest appreciation is expressed to them for their love, understanding, and inspiration. Without their blessings and encouragement, I would not have been able to finish this work. Most importantly, I wish to thank my loving and supportive husband, Gopal, and my beloved daughter Smera, who were very supportive and invested their time in pursuit of my dream.

TABLE OF CONTENTS

	PAGE
LIST OF TABLES	viii
LIST OF FIGURES	ix
LIST OF EQUATIONS	xi
CHAPTER 1. INTRODUCTION	1
Background.....	1
Statement of Problem	4
Purpose of the Study	5
Need for the Study	6
Assumptions of the Study.....	7
Research Question.....	8
Delimitations of the Study.....	8
Limitations of the Study	8
Definition of Terms.....	9
CHAPTER 2. LITERATURE REVIEW	11
Smartphones Sensing	11
Peripheral Devices for Smartphone Sensing	12
3.5mm Audio Interfaced Power Harvesting and Communication Technologies	18
Double Audio Channel Power Harvesting.....	18
Single Audio Channel Power Harvesting	22
Microphone Bias Power Harvesting.....	26

Summary.....	29
CHAPTER 3. METHODOLOGY.....	31
Audio Output Power Investigation	32
Mono Channel Configuration	32
Stereo Channel Configuration.....	32
Power Harvester Design.....	33
Power Harvester Design 1	33
Power Harvester Design 2	35
Microcontroller Sensing Circuit	36
Specifications for Microcontroller Transmitter	36
Joint Power Harvesting and Data Communication Technology.....	39
Specifications for Microcontroller Receiver.....	40
Sensing Prototype	44
CHAPTER 4. RESULTS AND DISCUSSIONS.....	46
Audio Output Power Investigations.....	46
Power Harvester Performance Evaluation.....	48
Power Harvester Design 1	50
Power Harvester Design 2	53
Sensing Prototype	55
Joint Power Harvesting and Communication Technology.....	57
Communication Protocol.....	59
Power Harvesting	59

Discussion.....	62
CHAPTER 5. CONCLUSION AND FUTURE RECOMMENDATIONS	64
Conclusion.....	65
Future Recommendation	66
REFERENCES.....	68
APPENDIX. TI-MSP430 F1611 DATASHEET	71

LIST OF TABLES

TABLE	PAGE
1 Comparison of Different Smartphones Interfaces to Connect External Sensors.....	3
2 Specification and Differences Between 3 Versions of Windoo Device	19
3 Manchester and Differential Manchester Communication Code	37
4 Example Settings for the FSK Communication System	42
5 Experimental Settings for Measuring the Power Output with Mono and Stereo Channel Configurations	46
6 Maximum Power Output and the Correspondence Voltage, Current and Load for the Mono and Stereo Channel Configurations.....	48
7 Experimental Settings for Performance Evaluation of Power Harvesting Design 1 and FSK Communication.....	49
8 Measurement Results for the Power Harvesting Circuit using Stereo Channel Configuration with Different Types of AC Signals	52
9 Measurement Results for Novel Power Harvesting Circuit	60

LIST OF FIGURES

FIGURE	PAGE
1. Market Share of Different Operating System in 2017	1
2. USB interfaced Smartphone Sensing Platform Architecture	14
3. Structure of the 3.5mm Audio Interface for Smartphones.	18
4. Block Diagram Windoo Smartphone Sensing Platform	20
5. Block Diagram Hijack Smartphone Sensing Platform.....	22
6. Power Harvester Circuit for Hijack Smartphone Sensing Platform	23
7. Data Communication Technology for Hijack Smartphone Sensing Platform ...	24
8. Block Diagram AudioDAQ Smartphone Sensing Platform.....	26
9. Power Harvester Circuit for AudioDAQ Smartphone Sensing Platform 1	28
10. A) Mono Channel Configuration B) Stereo Channel Configuration	33
11. Proposed Power Harvester Circuit 1 for Smartphone Sensing Platform	34
12. Proposed Power Harvester Circuit 2 for Smartphone Sensing Platform	35
13. Example Frame Structure for Transmitting 3 Bytes from Microcontroller	38
14. Block Diagram of the Joint Power Harvesting and Communication Technology	39
15. Midpoint Setting Circuit for Microcontroller Receiver	40
16. Microcontroller Demodulation Approach	43
17. Sensing Prototype Architecture	44
18. Output Voltage, Current, and Power of the 3.5mm Audio Interface using the Mono and the Stereo Channel Configurations	47
19. Power Harvester Performance Evaluation using stereo channel configuration.....	49

20.	Testing Circuit for Power Harvesting: (A) Step-up Transformer, (B) FET-based Bridge Rectifier, (C) Schottky Diode and Filtering Capacitors.....	50
21.	Voltages of the Power Harvesting Circuit using the Mono Channel Configuration with a Load of 500 ohm. AC Signal Type: (A) 16 kHz (B) 20 kHz (C) FSK. Channel 1 (orange): Input of Step-up Transformer. Channel 2 (green): Output of Rectifier. Channel 3 (blue): DC output	51
22.	DC Power Output vs. Frequency of the Sinusoidal Signal	54
23.	Experimental Setup for the Sensing Platform	56
24.	DC Power Output for the FSK Signal.....	59
25.	FSK Signal Obtained between the Left Earphone Channel	61

LIST OF EQUATIONS

EQUATION		PAGE
1	FSK Frequency f_0	41
2	FSK Frequency f_1	41
3	FSK Symbol duration T_{b0}	41
4	FSK Symbol duration T_{b1}	41
5	Averaging bit duration R_b	42
6	Estimate FSK Frequency f_0	57
7	Estimate FSK Frequency f_0	57
8	Estimate FSK Symbol duration T_{b0}	58
9	Estimate FSK Symbol duration T_{b1}	58
10	Estimate Averaging bit duration R_b	58

CHAPTER 1

INTRODUCTION

Background

The smartphone seems to be an emerging tool having solutions for the field of ubiquitous sensing and this has significantly changed the way smartphone resources are used. Smartphones as the devices provide not only mobile communications, but also powerful information processing, connectivity to internet, user interface, and storage abilities (Smartphone Users, 2014).

Smartphones are equipped with powerful processors and a multitude of built in sensors, which make them a promising tool to support various sensing applications. Smartphones can further be utilized to address a wide range of sensing applications by interfacing the external sensors to them. In 2014 the recorded number of smartphone users were 2.6 billion and this is expected to reach 6.1 billion by 2020 (Boxall, 2015). In Figure 1, the market share of different smartphones is categorized based on mobile operating system (Mobile/Tablet Operating System Market Share, 2017).

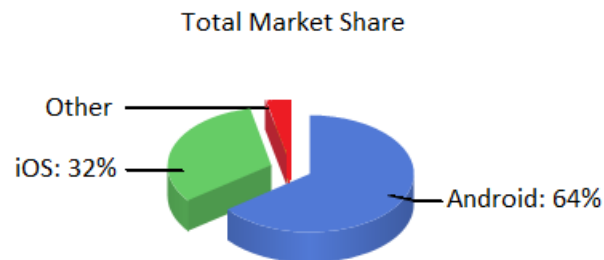

Figure 1. Market Share of Different Operating System in 2017

The wide applicability and popularity of smartphones opened a whole new area of research for smartphone peripherals to facilitate more sensing applications. Health care is one sector with huge need for a smartphone sensing platform. The low cost and mobility provided by a smartphone sensing platform make them useful for addressing critical health needs of people living in rural and undeveloped countries (Black et al., 2009). Such smartphone based sensing platforms are desirable in applications where low power sensors are interfaced to smartphones to attain low cost, flexibility and mobility and tradeoff the speed and security to some extent.

To implement a smartphone-powered sensing peripheral, the hardware and software interface need to be designed to supply the power to the external sensors and establish data communication between external sensors and a smartphone. Smartphones can connect to a variety of external sensors over wired and wireless channels. There are three available interfaces to connect smartphones to external sensors; Bluetooth, USB and Audio jack. These three interfaces are compared in Table 1.

Table 1

Comparison of Different Smartphones Interfaces to Connect External Sensors

Smartphone Interface/ Features	Bluetooth (Mint, n.d.)	USB (Black et al., 2009)	3.5mm Audio Interface
Type	Wireless	Wired	Wired
Data Communication	Yes	Yes	Yes
Power Output	No	DC	AC
Power to External Sensing Platform	External Battery Powered	USB Powered	External Battery Powered (Breathometer, 2017; Mint, n.d.; Nanobionics, 2017)
			Audio Power Harvesting Circuits (Kuo, Schmid, & Dutta, 2010)
Limitations	External Battery Cost.	Physically Non- Universal Hardware Interface	External Battery Cost Harvesters Designs supports iPhone only (Kuo et al., 2010) Harvester Designs limited to some Sensors only (Windoo, 2017)

Among various analog interfaces of smartphones, the 3.5mm audio interface is truly open to provide wide enough bandwidth to support the communication between external sensors and smartphones. The earphone channels in the 3.5mm audio interface only allow

alternative current (AC) signal being sent out from a smartphone; the interface cannot provide direct current (DC) power to external sensors. Thus, to address the power requirement of an external sensing platform, the peripheral devices need to use an external battery or a power harvesting circuit. This smartphone interface works with a broad range of headsets and hands free devices and is physically standardized across many smartphones (Verma, Robinson, & Dutta, 2012). The current research studies show various limitations because of electrical variations in the 3.5mm audio interface across different smartphones. This research explores the feasibility of audio interface to support various smartphone powered ubiquitous sensing applications across different smartphones. The purpose of this study is to analyze, design and build a smartphone powered external sensing platform. The main building blocks of the design are a power harvester circuit, a microcontroller based sensing platform, and Android smartphone and external sensors.

Statement of Problem

The problem of this research study is to build an Android smartphone-powered sensing platform that leverages the audio jack of Android smartphones to be powered and to establish data communication. Smartphones have become powerful computing platforms, which if used with external sensors can be converted to anything from educational tools to health monitoring devices. There has been considerable research to develop a 3.5mm audio interface smartphone powered sensing platform that can work with different types of smartphones. The maximum available power from the audio port of a smartphone is highly dependent on the output driver of the smartphone, therefore it

varies a lot between different manufacturers and even between models from the same manufacturer (Silicon Labs, 2017). The audio power output for Android is considerably low in comparison to iPhone and hence the existing 3.5mm audio interface technology works with iPhone only.

This research will address the problem by designing a new power harvester that can harvest enough power to support Android smartphones as well as iPhone. The data communication technology needs to be designed in adherence to support the maximum power harvesting with higher data rate using Android smartphones. The performance of the new power harvester design should be tested for efficiency to achieve at least the same, if not better performance with Android powered sensing platform in comparison to existing iPhone powered sensing platform.

Purpose of the Study

The purpose of this study is to design a sensing platform for Android smartphones, which can harvest power through the 3.5mm audio interface of the smartphone, receive measurement results from external sensors, and send control information from a smartphone to an external device. The objectives of this study are:

1. To design and develop a power harvesting circuit to power the microcontroller circuit on external sensing platform using the 3.5mm audio interface of the Android smartphone.
2. To design and develop the microcontroller circuit and hardware interfaces for external sensing platform.

3. To develop and integrate the prototype board consisting of 3.5mm audio interface, Microcontroller circuit and power harvesting circuit.
4. To define and develop the data communication protocol to establish two-way communications between Android smartphone and external sensing platform.
5. To test and analyze the performance of Android smartphone centric sensing platform based on the harvested power and the error free communication with smartphone.

Need for the Study

Smartphones OS market is shared among different smartphones as illustrated in Figure 1 (Mobile/Tablet Operating System Market Share, 2017). The three available interfaces to connect smartphones to external sensors are Bluetooth, USB and Audio jack. Only USB interface has the inherent capability to power and communicate with external sensors but not all smartphones have the same USB interface.

The need of this study is to address the lack of universal data interface in smartphones: Android phones use the micro-USB or USB Type-C interface and iPhones use a 30-pin dock connector or a Lightning connector, which are proprietary data interfaces. It means that the external sensing hardware designed for iPhones and iPads may not work with other types of smartphones and vice versa. This limits the market value of smartphone dependent smartphone sensing platforms and increases the production cost. To address this issue, existing smartphone based ubiquitous sensing platforms use 3.5 mm audio interface and get power either from smartphone battery or from external battery. The external battery powered sensing platforms not only increase

the size and cost of external sensing platform but also hurt user experience as the battery must be switched periodically. To avoid additional external battery, power needs to be harvested from an earphone channel. This issue was addressed in a previous study, where researchers built a hardware platform, which harvests power using one earphone channel of the smartphone and establishes two-way data communications using the other earphone channel and microphone (Kuo et al., 2010). However, the hardware platform cannot harvest enough power to support external sensors using smartphones other than iPhone.

Considering the analysis of 2017 market share, the Android operating system (OS) is the most popular OS holding 64% of the total share in smartphone industry (Mobile/Tablet, 2017). Hence, there is a need to address the lack of universal smartphone powered sensing platform that supports the huge market of Android phones.

Assumptions of the Study

For this research, certain assumptions are made that will serve as the basis for the calculations and measurements ensuring the performance of the design. These assumptions are:

1. The resistance values used for load calculations are relatively accurate.
2. The readings recorded from multi-meter and Oscilloscope are accurate.
3. The smartphones used for measurement and testing have uniform behavior for the same model.

Research Question

The goal of this research is to develop the Android smartphone sensing platform and evaluate its performance in sensing. The research questions for this study were:

1. Would the Android smartphones harvest enough power for the external sensing platform to support sensing applications?
2. What is the data communication technology between smartphone and sensing platform using Audio interface?
3. Would the joint power harvesting and communication technology achieve a reliable data communication?

Delimitations of the Study

This study is delimited to:

1. The Android smartphone model: ZTE Awe N800
2. The MSP430 Microcontroller on external Sensing platform

Limitations of the Study

The following limitations are to be applied to this study:

1. The developed prototype can be used with most Android smartphones and iPhones.
2. The developed prototype supports only low power sensors with operating voltage less than 2V.
3. The study is performed and tested with a few available Android smartphones.
4. The study is not analyzing the power dissipation of smartphone battery while attached to external sensing platform.

Definition of Terms

Sensors: A sensor is an electrical transducer that translates the physical properties into the electrical signals (Intro to Sensors, 2017). In various sensing applications, a sensor helps to decode the physical parameters from the environment or objects and provide it to the computing unit to make decisions and perform tasks.

Smartphone: The mobile phones today are known as smartphones as they can provide more than communication by rapidly replacing other gadgets, such as watches, cameras, video cameras, etc. (Smartphone Users, 2014)

Ubiquitous Sensing: Ubiquitous sensing is to embed the sensing invisibly into people's lives. Ubiquitous Sensing involves a sensor network with user interface that allows the sensing of people, the sensing of environment and the networking to other similar devices (Biru, Rotondi, & Minerva, 2015).

Microcontroller: A microcontroller contains a processor, memory and programmable input/output peripherals on a single chip. It can be programmed to perform specific tasks. Microcontrollers are present in smartphones, cameras, microwave ovens, washing machines, etc. (Future Electronics, 2017)

Sensing Platform: Sensing platform is the hardware platform that has sensor and its interface circuit to transfer the information to a processing unit or have on board a processor.

Sampling frequency: The sampling frequency can also be expressed as sample rate being the number of samples per second in an audio signal (Smith, 1997). Most Smartphones

have a sampling frequency of 44100 hertz implies a recording with a duration of 1 minute (60 seconds) will contain 2,646,000 samples (Sampling Frequency, 2004).

FSK: Frequency shift keyed is a modulation scheme where the carrier frequency is frequency shifted by the message bits. An FSK waveform, derived from a binary message consists of two frequencies f_0 and f_1 to represent bit '0' and '1' respectively (Middlestead, 2017).

Operating system: An operating system is a System Software for Smartphone phones that is responsible for the overall performance of the smartphone and can be used for classification and comparison of smartphones available in the market (Beal, 2011).

CHAPTER 2

LITERATURE REVIEW

Smartphones Sensing

Smartphone sensing requires a user Application (App; Beal, 2011) running on the smartphone phone operating system, a sensor internally (Sensor Overview, 2017) or a sensor externally attached to the smartphone and data logging of sensed data. The phone operating system offers an Application Programming Interface (API) for building software applications to make smartphones a user interface in sensing applications. In 2005, Nokia workshop had a discussion focused on smartphones as a user interface for existing sensor networks which then led to the start of Nokia SensorPlanet project with an aim to explore the future of smartphone sensing (Campbell & Choudhury, 2012). In 2007 Nokia released the smartphone N95 with an embedded accelerometer for video stabilization and photo orientation. The API for accelerometer was released later in that year and this launch immediately led researchers to study and develop new phone-based sensing applications.

We do not realize how sensing is making our daily life easy and productive as we are surrounded by a multitude of sensors in the form of appliances and equipment at our home and work. In various sensing applications, a sensor helps to decode the physical parameters from the environment or objects and provide it to the computing unit to make decisions and perform tasks. With advancement in computing technology, we are surrounded by computers of different sizes, and the emergence of smartphones led to a new era for ubiquitous sensing. Most smartphones have built-in sensors like-

accelerometers, barometers and magnetometers (Sensor Overview, 2017). Smartphones API is used to read raw data from sensors to control other features on the phone and to provide user interface. Smartphone sensing using inbuilt sensors has various useful applications like, in gaming applications where you want to monitor device movement or positioning, or in weather applications where you want to monitor changes in the ambient environment near smartphones (Sensor Overview, 2017). Modern smartphones have a large set of inbuilt sensors, which support social, educational, entertainment, environmental, and health related sensing applications. These sensing features can be easily accessed by downloading different smartphone apps.

To increase the usability of smartphones and to broaden the range of sensing applications, the researchers integrated external sensors to the smartphones. The use of smartphone for sensing applications is convenient and shows great demand for Smartphone sensing platforms in consumer applications.

Peripheral Devices for Smartphone Sensing

There are a variety of sensors available in the market to apply control and decision making to almost any process. In the past few years various smartphone centric ubiquitous sensing applications have emerged, which jointly use a smartphone with external sensors for sensing applications (Breathometer, 2017; Black et al., 2009; Mint, n.d.; Nanobionics, n.d.; Square, n.d.; Verma et al., 2012; Windoo, 2017; Kuo et al., 2010). Smartphones can connect to a variety of external sensors over wired and wireless channels. To make external sensors work the hardware and software interface needs to be

designed to supply the power to the external sensors and establish data communication between external sensors and a smartphone.

The Breathometer Mint is a wireless sensing device that users can connect to their smartphone and perform breath analysis to understand their oral health. Mint device supports Android and iOS smartphone devices and uses Bluetooth LE technology for connection. Mint device measures volatile sulfur compounds (VSCs) in the mouth, which helps the smartphone user to plan a dental visit to treat poor oral health (Mint, n.d.). The iDevices Thermostat from Apple allows you to control the temperature of your home using iPhone; or Siri voice commands. The iDevices Connected app and Apple HomeKit technology makes it easy to control iDevices Thermostat based on your daily routine (iDevices Thermostat, 2017). Although, wireless technology in smartphones supports the data communication with external sensing platform, the power requirements of external sensing platform need an external battery between smartphone and external sensing platform.

The research in (Black et al., 2009) proposed the prototype for smartphone based health devices and mobile phone applications called mHealth to aid health workers in remote and underserved areas. The proposed architecture for health devices is shown in Figure 2, which uses USB interface of a smartphone to establish the connection with the microcontroller as well as provide power to the microcontroller, and the external medical sensors are attached to the analog or digital ports of the microcontroller. The mHealth applications support Java Micro Edition programming language and operating systems such as Nokia OS and Symbian OS, iPhone OS, Android, and others.

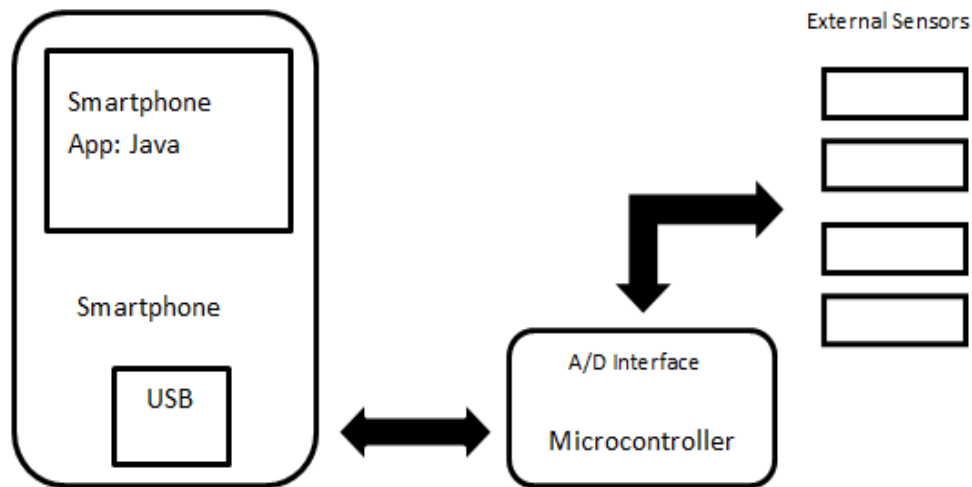

Figure 2. USB Interfaced Smartphone Sensing Platform Architecture

The research proposed five mHealth applications; a respiratory and pulse rate calculator, a gestational date calculator, a formulary/drug dose calculator, a drip rate calculator, and a drug reminder alarm. The researchers developed a low-cost Nossal Oximeter device, a microcontroller attached to an oximeter probe to leverage smartphone's processing and interface capabilities. Nossal Oximeter device is tested with the mHealth application and is useful for the diagnosis and assessment of severity of respiratory disease.

Although, USB interface supports the data communication and power requirements with external sensing platform, it is not a universal hardware interface since physically the USB interface varies (Verma et al., 2012). The demand to build a universal external sensing platform has led researchers to search for a universal peripheral interface port. This is how 3.5 mm audio interfaced peripherals gained attention.

In (Square, 2017) Square Inc. developed a device which converts a smartphone into a mobile point of sale machine and allows everyone to accept credit card payment. The device acts as a small magnetic reader that plugs into the headphone jack of a smartphone. The swiped credit or debit card information is converted to an audio signal and is fed into the microphone input of a smartphone. The smartphone processor then routes this information to Square's software application on the smartphone. Smartphone application encrypts the data for security purpose and transmits it using either Wi-Fi or a 3G Internet connection to back-end servers, where a connection is established with the payment networks to complete the transactions. The Square inc CEO Jack Dorsey states what accounted for invention and popularity of Square card reader: the smartphones are ubiquitous with low-cost and have powerful processors to conduct complex tasks and increase the use of electronic payment using credit or debit cards (Malik, 2009).

Breathometer is an audio/headphone jack interfaced device used in conjunction with a mobile application to transform a smartphone into a breathalyzer to estimate your Blood Alcohol Content; BAC (Breathometer, 2017). The Breathometer device supports iPhones and Android 2.3 or above and the free mobile application (App) is available for downloads from the iTunes or Google Play store respectively (Breathometer review , 2014).

In (Nanobionics, 2017), MoboSens is a smartphone based sensing platform for accurate nitrate concentration measurements in water. MoboSens is developed by a research group at University of Illinois to allow citizens to conveniently monitor water quality. MoboSens Application on smartphone uses GPS and mobile broadband to collect

and share environmental data to spread awareness. The information generated using the MoboSens device is shared on social media, and Nitrate Sensing Maps are available on both phone and internet.

The square card reader, breathometer device and Mobosens device are battery powered, not only increasing the size and cost of these devices, but also hurting user experience as the battery must be renewed periodically. Recent studies used energy harvesting techniques to implement smartphone powered sensing platforms. Power harvester circuit is present on the external sensing platform and harvest DC power from the Audio channel interface of the smartphone.

In (JDC Electronics, 2016; Windoo, 2017) JDC Electronic SA developed Skywatch Windoo, a weather station for your smartphone. The Skywatch Windoo device is attached to a smartphone using a headphone jack and is compatible with ios and Android smartphones. Skywatch Windoo 3 allows one to monitor wind speed, temperature, humidity and pressure for any outdoor activities, and measured data can be stored and shared on Facebook, twitter or Windoo.ch.

The researchers at University of Michigan developed an efficient power harvesting design called Hijack to drive external sensing platforms without giving up on communication from the smartphone to sensing platform (Kuo et al., 2010). The external hardware design consists of the microcontroller based sensing platform and the 3.5mm audio interfaced energy harvesting circuit. This architecture supports the power harvesting and communication technology for smartphone sensing platforms. An oscilloscope application is used by the researchers to demonstrate the functions of the

developed sensing platform. The device is small enough to carry along with the smartphone, so it can be used as a portable oscilloscope for engineering students.

After the Hijack design, the researchers at University of Michigan presented a new platform, called AudioDAQ, which harvests energy from the microphone bias signal of a smartphone and provides both power and communication to external sensor (Verma et al., 2012). The AudioDAQ design is universal across different smartphones for limited sensing applications. The AudioDAQ platform supports a broad range of smartphones for data acquisition from analog peripherals without using a microcontroller. The AudioDAQ architecture is demonstrated by low-power EKG monitors that capture cardiac signals and store this data on Cloud.

Recent research has used the power harvester techniques in place of the external battery to reduce the cost of the design and to improve the user experience. These studies show that the existing power harvesting techniques are still not meeting the requirements for a universal sensing platform as the 3.5mm audio interface is universal physically but not electrically. The electrical characteristic of audio interface limits the compatibility of sensing platforms with different smartphones and sensors. Windoo device, Hijack device and AudioDAQ device are three existing power harvesting designs that are discussed in detail in the next section of this literature review with focus on the limitations of harvesting techniques and data communication technologies.

3.5mm Audio Interfaced Power Harvesting and Communication Technologies

The structure of the 3.5mm audio interface is shown in Figure 3. We can see that the audio interface for smartphones has four connectors: the connectors A and B are respectively the left and the right earphone channels, which send audio signal out from a smartphone; the connector C is the common/ground; and the connector D is the microphone channel, which sends audio signal into a smartphone (Kuo et al., 2010).

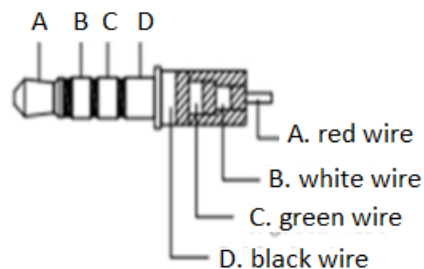

Figure 3. Structure of the 3.5mm Audio Interface for Smartphones.

To implement smartphone powered ubiquitous sensing applications using the 3.5mm audio interface Windoo, Hijack and AudoDaq device implemented different power harvesting and data communication technologies, which are studied in detail under this section.

Double Audio Channel Power Harvesting

Double channel power harvesting (DCPH) technology uses both left and right earphone channels for power harvesting. Windoo device is based on DCPH technology and has three versions; Windoo 1, Windoo 2 and Windoo 3 (JDC Electronics, 2016).

These devices can be useful for environmental monitoring during outdoor recreational services. The specifications and features of three versions are compared under Table 2 (JDC Electronics, 2016).

Table 2

Specifications and Differences Between 3 Versions of Windoo Device

Features	Specifications	Windoo 1	Windoo 2	Windoo 3
Wind Speed	Resolution: ± 0.1 km/h Min: 3km/h; Max: 150km/h Accuracy $\pm 2\%$	✓	✓	✓
Temperature	Resolution: 0,1 units Min: -25 °C; Max: 60 °C Accuracy ± 0.3 °C	✓	✓	✓
Humidity	Resolution: 0,1 units Accuracy ± 4 %RH Min: 5 %RH; Max: 95 %RH	X	✓	✓
Pressure	Resolution: 0,1 units Accuracy ± 0.2 hPa Min: 300 hPa; Max: 1100 hPa	X	X	✓
Dimensions	20 mm, length 52 mm			
Weight	38 g			

(Table continues)

Smartphones	<p>Apple: iPhone (4S, 5, 5C, 5 S), iPad mini(2, 3), iPod touch</p> <p>Samsung: Galaxy (S3, S4, S4 mini), Galaxy Tab 10.1, Galaxy Note</p> <p>2 Others: Nexus 4, HTC One S</p>
Software OS	<p>Software iOS 6.0 or newer</p> <p>Android Ice Cream Sandwich (4.0) or newer</p>

Sensing platform. The Windoo Smartphone Sensing platform block diagram representation is shown in Figure 4. The device consists of 3.5mm audio interface plug, a power harvester circuit and a Swiss-made sensor set. All components are enclosed in tiny aluminum housing with multidirectional propeller spin on top of the device to measure wind speed and direction. The Swiss-made sensor set can measure temperature (and wind chill), humidity and pressure. The device sends all the weather information to the accompanying smartphone app, where it can be viewed and stored/shared on Facebook, Twitter and Windoo's websites. The app can also graph and map the data (JDC Electronics, 2016; Windoo, 2017).

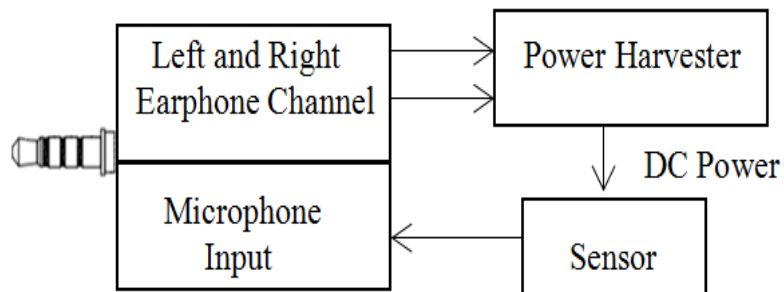

Figure 4. Block Diagram Windoo Smartphone Sensing Platform

Power harvester and data communication technology. The Windoo devices, use both left and right earphone channels to harvest power from the smartphone and supply it to external sensors. The sensor on external Windoo devices continuously sends information to the smartphone by establishing one-way communication from an external sensor to the smartphone. To get more power from smartphones, researchers harvest power using both earphone channels. The harvester shorts the left and the right earphone channels to increase the signal amplitude (JDC Electronics, 2016; Windoo, 2017).

Smartphone firmware. A specific smartphone App is required to be downloaded and installed on smartphones to support Windoo devices power harvesting and data communication architecture. Windoo devices supports Android and iPhones and the respective Apps can be found in App Store (iTunes, 2017) or the Google Play Store (Skywatch Windoo, 2017).

Limitations. Windoo.ch app generates identical in phase AC signals on left and right earphone channels to harvest power for an externally attached Windoo device (JDC Electronics, 2016). The approach gives up the communication from the smartphone to the Windoo device. This design is not applicable to the wide variety of sensors or microcontroller based sensor platforms where control is needed from the smartphone user interface. Windoo technology can only handle simple sensors because the only control from the smartphone is disconnecting the power, and the external sensor sends information to the smartphone in a repeat pattern.

Single Audio Channel Power Harvesting

Single channel power harvesting (SCPH) technology uses one earphone channel for power harvesting. Hijack device is a microcontroller based sensing platform which uses SCPH technology. The sensing platform with a microcontroller has several benefits; it allows multiplexing of inputs, and it allows interfacing of different sensors by supporting interfaces like ADC, GPIO, I2C, SPI, UART, or other (Kuo et al., 2010).

Sensing platform. The Hijack device consists of 3.5mm audio interface plug, a power harvester circuit and a microcontroller based sensing circuit. The block diagram representation for Hijack device is shown in Figure 5.

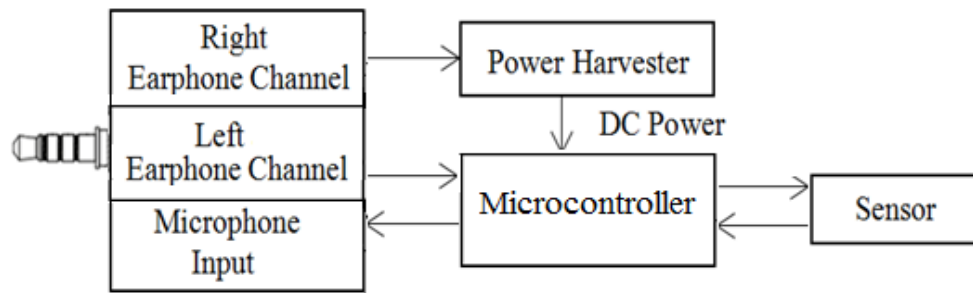

Figure 5. Block Diagram Hijack Smartphone Sensing Platform

Hijack device in conjunction with iPhone is used to demonstrate different sensing applications. The designed application runs partly on the iPhone and partly on Hijack sensing platform. The research demonstrated how the Hijack device when attached to an iPhone turns an iPhone into an inexpensive oscilloscope, EKG monitor, and soil moisture sensor.

Power harvester and data communication technology. The Hijack device uses the right earphone channel output for energy harvesting to power the external sensing platform. The left earphone channel and microphone are used to establish two-way communications between the smartphone and sensing platform.

Power Harvester. The Hijack power harvester circuit as shown in Figure 6 aims to harvest energy from an iPhone Audio channel to power the microcontroller and sensors on external sensing platform.

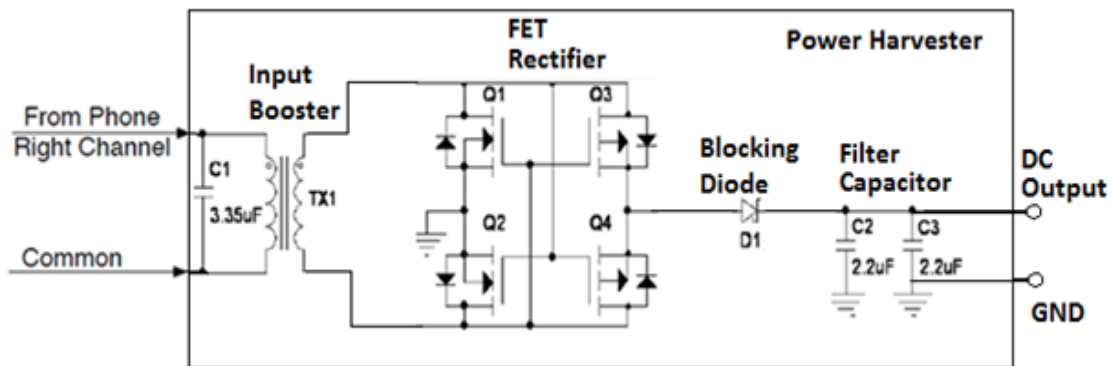

Figure 6. Power Harvester Circuit for Hijack Smartphone Sensing Platform

The power harvester circuit sidesteps the two engineering challenges (Kuo et al., 2010):

- Increase the signal amplitude, and
- Convert the AC signal into a DC signal

The low voltage sinusoidal signal output from right audio channel is first boosted using 1:20 micro transformer circuit. The boosted AC signal output is then rectified to DC signal using the FET rectifier bridge (Q1, Q2, Q3, Q4). The Schottky diode (D1) is

used to block the filter capacitor (C2, C3) discharge through the FET bridge. The DC output of the harvester circuit is further used to power the microcontroller circuit and external sensors on the sensing platform.

Data Communication. This technology supports two-way communication between the smartphone and sensing platform; the left audio channel sends a data stream coded with Manchester code to the microcontroller (on the smartphone sensing platform), and the microphone input (on the smartphone) receives a data stream coded with Manchester code from the microcontroller. Both the phone and the microcontroller implement Manchester decoding to recover the data (Kuo et al., 2010). The bi-directional communication between the phone and microcontroller supports 8.82 kbps data rate. The data communication technology illustrated in Figure 7 uses several hardware features on microcontroller to efficiently modulate and demodulate FSK signals.

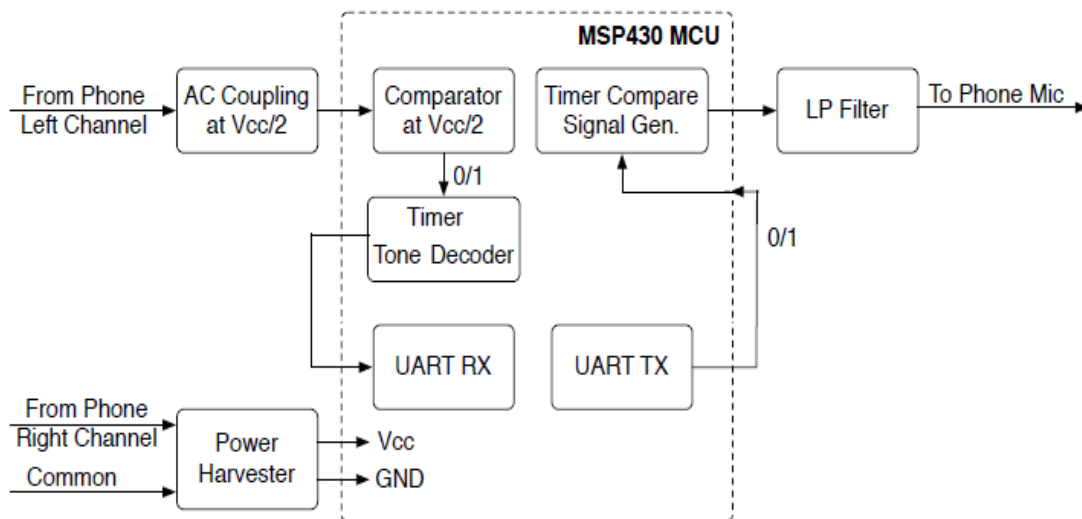

Figure 7. Data Communication Technology for Hijack Smartphone Sensing Platform

Microcontroller Decoder: The comparator, timer capture and UART receiver peripherals are used to detect the incoming data stream from the left audio channel of the smartphone. The comparator at $V_{cc}/2$ is used to interpret the incoming Manchester encoded signal into ones and zeros. The output of the comparator is driving the timer capture unit sensitive on both rising and falling edges. The timer unit captures the time between successive samples and estimates the symbol width. The output of timer decision is then externally connected back into the receiver port of the UART peripheral. The UART receiver is then responsible for decoding the frame.

Microcontroller Encoder: The timer capture and UART transmitter peripherals are used to transmit data stream into the microphone input of the smartphone. The UART transmitter first generates the output data bits at 300 baud. The generated bits are fed back into a microcontroller interrupt line and a timer compare unit is used to correct the frequency. The square wave output of the timer compare is then filtered and fed into the microphone input of the smartphone.

Smartphone Firmware. A specific smartphone App is used to support Hijack device power harvesting and data communication architecture. Hijack device supports iPhones and the respective Apps can be found in App Store (iTunes, 2017). The application running on iPhone generates a 22 kHz tone on the right audio channel to power the microcontroller using the power harvester circuit.

Limitations. The study shows that the energy harvesting hardware delivers 7.4 mW to a load using the iPhone's headset port. But for many other smartphones, like Android,

this hardware platform cannot harvest enough power to support various ubiquitous sensing applications (Kuo et al., 2010).

Microphone Bias Power Harvesting

Microphone bias power harvesting (MBPH) technology uses microphone bias voltage for power harvesting. AudioDAQ is an audio interfaced data acquisition platform which uses the MBPH technology to power external sensors. The design interfaces the simple analog peripherals directly to the smartphone without using a microcontroller (Verma et al., 2012).

Sensing Platform. AudioDAQ device leverages the smartphone resources for capturing, storing and processing analog sensor data. The block diagram representation for AudioDAQ device is shown in Figure 8. The external sensors get powered using the microphone bias voltage through a linear regulator. The external sensor data is encoded as analog audio using the phone's built-in voice memo application or any custom created App. This design is more universal as it works across a broad range of phones.

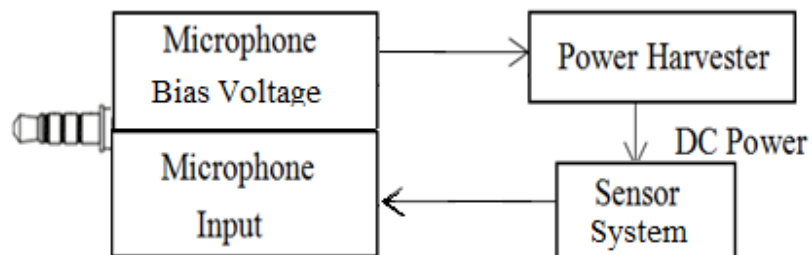

Figure 8. Block Diagram AudioDAQ Smartphone Sensing Platform

The AudioDAQ device consists of 3.5mm audio interface plug, a linear regulator circuit and a sensor circuit. The research demonstrated a data acquisition platform that captures EKG signal continuously and stores it on Cloud for further processing, and visualization.

Power harvesting and data communication technology. The microphone channel is used both to power external sensors and to input sensor data into the smartphone. The design needs to consider that the power supply and data transfer characteristics are deeply coupled. The Microphone harvester design includes three important blocks: internal microphone circuit, microphone power harvester and sensor communication interface shown in Figure 9.

Power harvester. The AudioDAQ power harvesting design uses the microphone bias voltage to power external sensor with an aim to address the issue with Hijack design which was not able to work with different smartphones. This design circuit is universal enough to work across many smartphones for data acquisition using simple analog sensors.

The AudioDAQ requires 1.8 V open-circuit voltage of the microphone bias line to make it compatible with nearly all the smartphones. The microphone bias voltage acts as a high-impedance voltage source with its current limiting resistance $R1$. A microphone harvester circuit uses a linear regulator to provide stable supply to the external sensor. The RC filter at input of a regulator stabilizes the linear regulator and prevents regulator control loop noise.

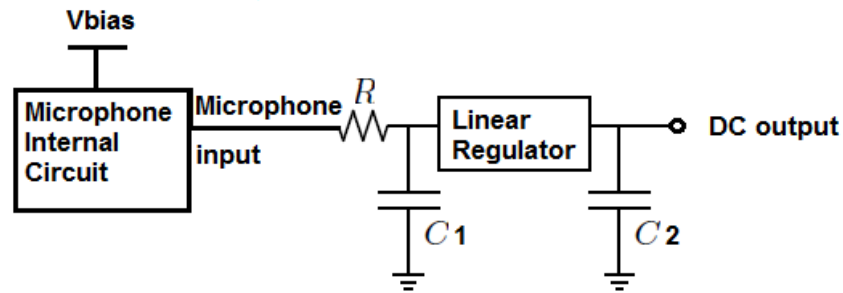

Figure 9. Power Harvester Circuit for AudioDAQ Smartphone Sensing Platform 1

Data communication. The Microphone input of the smartphone is band limited to amplitudes around 10 mV peak-to-peak, and audio frequencies in the 20 Hz to 20 kHz range. To pass signals which are below 20 Hz or are DC in nature, the design modulates the analog signal into the audio passband using an analog multiplexer. The analog multiplexer is driven from a counter and is clocked with an RC oscillator at 1.2 kHz to produce an analog signal from the sensors to a voltage anywhere between system ground and the reference voltage of 1.8 V. To limit the input voltage range, a scaling resistor R4 is used between the output of the multiplexer and the microphone bias line. The raw signal captured by the phone's microphone line is recorded and can be transmitted to a computer for further processing and decoding.

Limitations. The AudioDAQ design is useful for data acquisition applications where low power sensors are used for continuous monitoring for long time periods. The sensing platform using a microphone line is not capable of supporting an arbitrary hardware peripheral. The range of sensors it supports is still limited and hence it can't be used as a universal sensing platform.

Summary

The advancement in sensor and embedded technology opened the doors for several ubiquitous sensing applications. Using a Smartphone headset port as a peripheral interface for data communication is ubiquitous and seems as an attractive option for making peripheral devices platform independent. All these recently introduced peripherals, like the Square card reader (Square, 2017), Breathometer (Breathometer, 2017), Mobosens (Nanobionics, 2017), Windoo (Windoo, 2017) and hijack (Kuo et al., 2010) reflect a growing interest in using the headphone jack for more than just headsets. However, there are features associated with smartphones from different manufacturers, and even for different models from the same manufacturer, which vary considerably and result in the incompatibility between peripheral devices and smartphones.

Audio interface only allows alternative current (AC) signal in the audible frequency range, which is not suitable for direct current (DC) powered peripheral devices. The smartphone independent sensing platforms like Square card reader, Breathometer and MoboSense are battery powered which increases the size and cost of external devices and hurts user experience as the battery must be changed periodically. The research in (Kuo et al., 2010; Verma et al., 2012; Windoo, 2017) leverages the audio jack driver to harvest energy for peripheral devices.

Hijack and Windoo use custom written phone software on the smartphone to generate sinusoidal waveform at the audio output which is fed to the energy harvesting circuit for the peripheral devices. The energy harvesting from the audio output presents significant design challenges. The Skywatch Windoo device shorts the left and the right

earphone channels to harvest more power using both channels of the smartphone. This approach results in no communication from the smartphone to the microcontroller. The output power capability of headphone jacks differs a lot from Android to iPhones, Android headphone jack power output is considerably low in comparison to iPhone resulting in the peripherals built to work with the iPhone not working on many Android phones; like the Hijack device is limited to work with iPhone only. The AudioDAQ system uses the microphone bias voltage to power peripherals and it has limitations due to the coupling of data transmission and energy harvesting on the microphone channel. The microphone line is limited to support some hardware peripherals showing trade-off between signal reconstruction and maximum power delivered (Verma et al., 2012).

The literature review leads to the conclusion that several currently developed smartphones powered sensing platforms are either not supporting Android smartphones(Hijack) or address limited sensing applications (Windoo, AudioDAQ). Smartphone peripheral sensing platforms are truly disruptive and the outcomes of this review will help in the design of a 3.5mm audio interfaced ubiquitous sensing platform having the potential to meet consumer applications for different smartphone sensing applications.

CHAPTER 3

METHODOLOGY

This research involved the design and development of a smartphone powered ubiquitous sensing platform with the capability to harvest enough power using Android smartphones to support various sensing applications. To design an Android ubiquitous sensing platform, we chose the 3.5mm audio interface to connect the Android smartphone with the external sensing platform.

This research addresses various limitations of existing smartphone powered sensing platforms. A smartphone sensing platform consists of a power harvester circuit and a microcontroller circuit with external sensor interface. First, different power harvester designs are examined using different configurations and modulation schemes with left and right earphone channels in the 3.5mm audio interface. The performance of power harvester and useful modulation schemes for data communication is tested using Android smartphones. The results are evaluated based on the output DC power of the power harvester circuit.

After finalizing the power harvesting and data communication technology, the microcontroller circuit and its interfaces are designed and developed. The smartphone is indirectly interfaced to external sensors via a microcontroller. The microcontroller circuit uses audio channel interface to establish two-way data communication with the smartphone. The microcontroller based sensing platform can connect to a wide variety of sensors over different communication protocols to support various sensing applications.

The two main building blocks of this smartphone powered sensing platform are following:

- Power Harvester circuit
- Microcontroller sensing circuit

Audio Output Power Investigation

This investigates the output power of the audio interface with two types of channel configurations. The results of these configurations are used to define the input interface of the power harvester circuit in the sensing platform. The experimental setup for Mono and Stereo Channel Configuration is shown in Figure 10 A and B respectively.

Mono Channel Configuration

As shown in Figure 10.A, in the mono channel configuration, a load is connected between the right earphone channel and the common/ground of the 3.5 mm audio interface. This configuration is to duplicate the hardware setup used by Hijack device (Kuo et al., 2010).

Stereo Channel Configuration

The stereo channel configuration is our newly proposed configuration for joint power harvesting and data communications. As shown in Figure 10.B, in the stereo channel configuration, a load is connected between the right and the left earphone channels. Meanwhile, the AC signals outputted by the right and the left earphone channels are designed to have 180-degree phase difference (i.e. the two signals are opposite to each other).

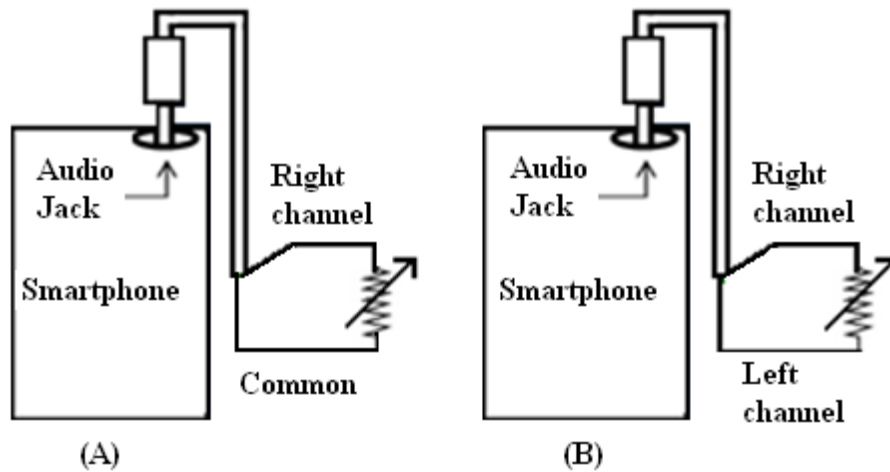

Figure 10. A) Mono Channel Configuration B) Stereo Channel Configuration

Power Harvester Design

The study involves the development and testing of two different power harvester designs. The hijack device uses single audio channel (Mono channel configuration) for power harvesting and it is expected that using both earphone channels (Stereo channel configuration) with proper modulation scheme the DC output will increase.

Power Harvester Design 1

In literature review, the research conducted by [Michigan] used the mono channel configuration where the power harvester is connected between the right earphone channel and the common/ground of the 3.5 mm audio interface. The proposed power harvester design is like the one given by [Michigan] except that the stereo channel configuration is used instead of the mono channel configuration. The circuit for Power harvester design 1 is shown in Figure11.

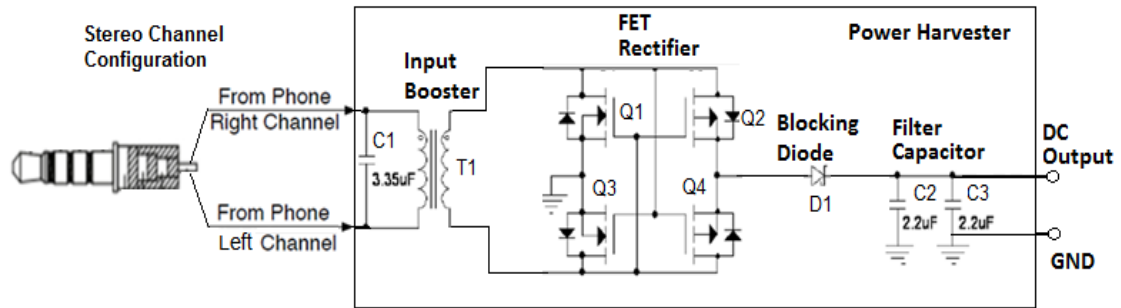

Figure 11. Proposed Power Harvester Circuit 1 for Smartphone Sensing Platform

The output of the stereo channel configuration is first boosted by the combination of a capacitor (C1) and a 1:10 step-up transformers (TX1), and then the boosted signal is rectified by a FET-based full wave bridge rectifier (Q1~Q4). Here using FET switches instead of diodes, the voltage loss during the rectification is reduced (Seeman, Sanders, & Rabaey, 2007). The function of the Schottky diode (D1) is to block the discharging current from the capacitors (C2 and C3) to the rectifier. Finally, the rectified signal is filtered by a lowpass filter (C2 and C3) to generate the DC power output.

The sensing platform establishes two-way data communications with a left or right earphone channel (from the smartphone to the microcontroller) and the microphone channel (from the microcontroller to the smartphone; Kuo et al., 2010). This architecture of the sensing platform using stereo channel configuration is named joint power harvesting and communication technology.

Power Harvester Design 2

The Power harvester design 2 is shown in Figure 12. It is a quadrupler circuit based novel power harvesting design that can generate DC power with enough high voltage without using a transformer.

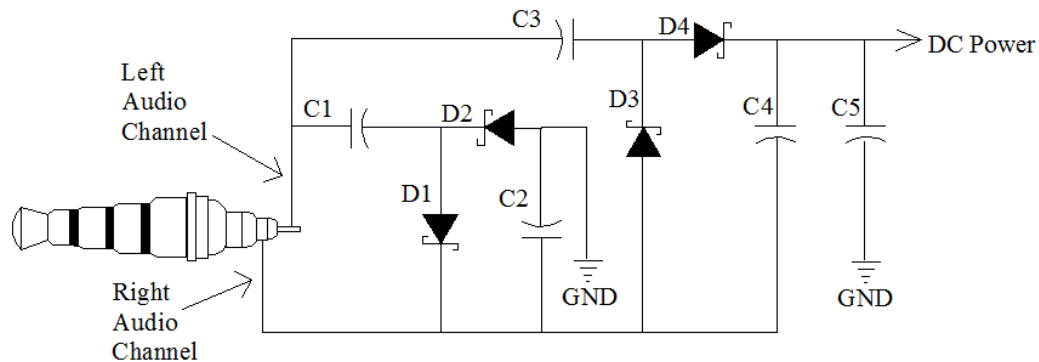

Figure 12. Proposed Power Harvester Circuit 2 for Smartphone Sensing Platform

A voltage quadrupler circuit can boost the input signal without the use of a transformer. Theoretically, the combination of capacitors and Schottky diodes can boost the peak-to-peak voltage between the two earphone channels by four times considering the small voltage drop on the Schottky diodes (D1~D4) is omitted. Thus, the power harvesting circuit can provide the similar voltage of DC power as that in (Kuo et al., 2010) can.

This architecture of the sensing platform is a joint power harvesting and communication technology using stereo channel configuration. The right earphone channel is connected to the ground of the power harvesting circuit through a large

capacitor C2, so the voltage difference between the right earphone channel and the ground is a DC value. Thus, the FSK signal for demodulation at the microcontroller needs to be obtained between the left earphone channel and the ground of the power harvesting circuit.

Microcontroller Sensing Circuit

The external sensing platform uses a low power microcontroller to connect external sensors to the smartphone. The 3.5mm audio interface is used to establish two-way data communication between microcontroller and the smartphone. The earphone channel is used to communicate from the smartphone to the microcontroller and the microphone channel is used to communicate from the microcontroller to the smartphone.

Microcontroller has different interfaces for gathering information from variety of external sensors. Microcontroller translates and sends the sensor readings to the smartphone on the microphone channel.

The Olimex MSP430f1611 prototype board is used to implement external sensing platform. The MSP430 family of Texas Instruments is an ultralow power microcontrollers class combined with five low power modes to achieve extended battery life in portable sensing applications (TI MSP430 Datasheet, 2017). The IAR embedded workbench IDE is used for software implementation.

Specifications for Microcontroller Transmitter

The microcontroller (MCU) transmits the sensor information on microphone input channel of the smartphone. The codec of a smartphone records it as a sound signal; the phase of a sound may have a 180 degree shift which is not noticeable because our ears do

not detect phase but frequency. However, for data communications from MCU to Smartphone, phase information is used to modulate bit information, so we must tackle this phase ambiguity. Thus, we proposed differential Manchester codes to transmit bit information from an MCU to a smartphone.

Differential Manchester Coding. The Differential Manchester Code is a variation of the Manchester code. It is a biphasic code illustrated in Table 3; for bit ‘0’ transmission, the current Manchester code is the same as the previous Manchester code, and for bit ‘1’ transmission, the current Manchester code is opposite to the previous Manchester code (Data Encoding Techniques, 2017).

For example, if the previous Manchester code is “01”, the current Manchester code is “01” when bit ‘0’ is transmitted, and “10” when bit ‘1’ is transmitted; if the previous Manchester code is “10”, the current Manchester code is “10” when bit ‘0’ is transmitted, and “01” when bit ‘1’ is transmitted.

Table 3

Manchester and Differential Manchester Communication Code

Original Data	Output (transition at bit center)	
	Manchester Code	Differential Manchester Code
Logic 0	0 to 1	No change in Phase
Logic 1	1 to 0	Change in Phase

Frame structure for Transmitter. The Bit information is transmitted in frames using timer compare unit of microcontroller. The beginning of each frame is Preamble bits 16 “01” Manchester code followed by a “10” start bit then a byte and an odd-parity

modulated with differential Manchester code. If there is more data to send a bit '1' (Differential Manchester Code) is transmitted before the next byte and the associated parity bit. After all bytes and associated parity bits are transmitted, four bits "0101" modulated with differential Manchester code are transmitted to indicate the end of the frame.

An example frame is given in Figure 14.

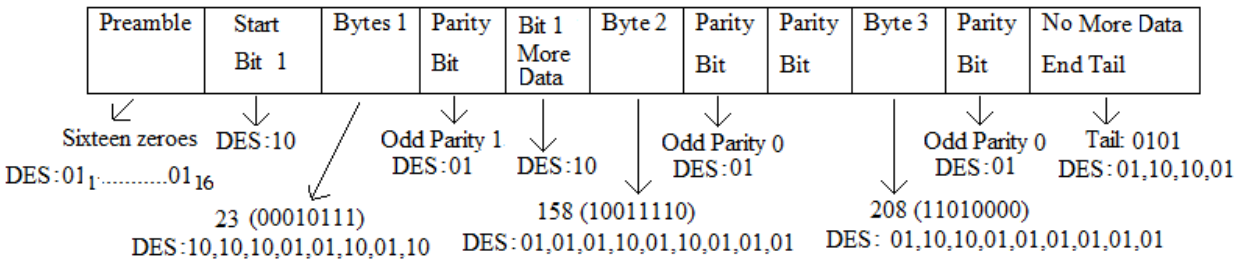

Figure 13. Example Frame Structure for Transmitting 3 Bytes from Microcontroller

Information bytes: 23 (00010111), 158 (10011110), 208 (11010000)

Information bytes with parity bits: 23(00010111-1), 158(10011110-0), 208(11010000-0)

Differential Manchester coding output:

- Preamble: 01,01,01,01,01,01,01,01,01,01,01,01,01,01,10
- Bytes 1: (23) 10,10,10,01,01,10,01,10,01
- Bit '1' before Bytes 2: 10
- Bytes 2: (158) 01,01,01,10,01,10,01,01,01
- Bit '1' before Bytes 3: 10

- Bytes 3: (208) 01,10,10,01,01,01,01,01
- Tail: 01,10,10,01

Joint Power Harvesting and Data Communication Technology

In this research, based on frequency shift keying (FSK) modulation scheme, we proposed a joint power harvesting and communication technology that can simultaneously harvest power and transfer data with the same earphone channels. The block diagram of a joint power harvesting and communication technology is shown in Figure 13. In comparison to single channel harvesting (Kuo et al., 2010), this technology is expected to harvest more than doubled power from both earphone channels without affecting the data communications between a smartphone and a microcontroller. After reviewing the different characteristics of data rates and output power of the two power harvesting circuits, we will use the most efficient design to develop smartphone powered sensing prototype.

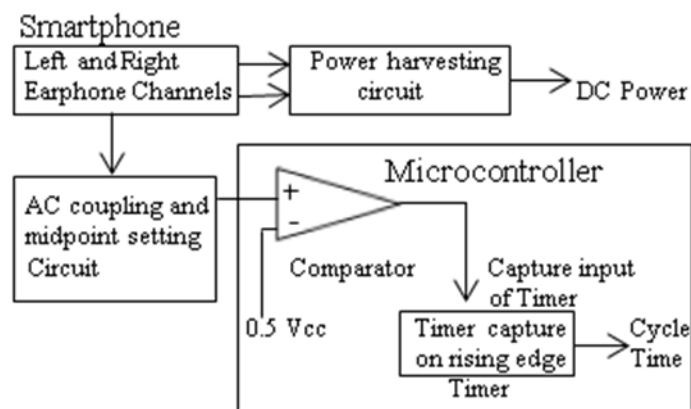

Figure 14. Block Diagram of the Joint Power Harvesting and Communication Technology

Specifications for Microcontroller Receiver

The FSK signal from one of the earphone channels is sent to an AC coupling and midpoint setting circuit shown in Figure 15 (Kuo et al., 2010); to shift the midpoint of the FSK signal to $V_{cc}/2$, where V_{cc} is the supply voltage of the microcontroller.

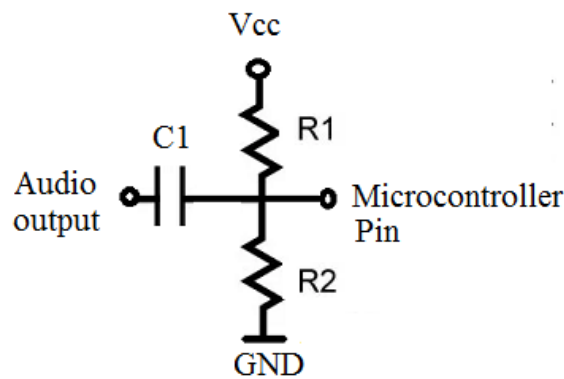

Figure 15. Midpoint Setting Circuit for Microcontroller Receiver

Then a comparator in the microcontroller, which is internally referenced to $V_{cc}/2$, converts the FSK signal into a digital signal, and a timer in the microcontroller times the duration between any two adjacent rising edges of the digital signal. Finally, the microcontroller recovers the data information as “0” and “1” from the timing outputs.

The key technical challenge to implementing the joint power harvesting and communication technology is to design an FSK demodulation approach in which a low-power microcontroller can perform the demodulation with stringently limited resources.

In this research, we have proposed a novel noncoherent FSK demodulation approach,

which uses a timer to measure the duration between two adjacent rising edges of the FSK signal. Because the timer in a microcontroller is typically driven by a high-speed clock, this approach can differentiate the two modulation frequencies in a much better way.

The smartphone uses a sampling clock, f_s , at 44.1 kHz. An FSK signal transmitted from the smartphone uses two different frequencies; f_0 to represent bit “0” and f_1 to represent bit “1”.

$$f_0 = \frac{M_0}{N} f_s \quad (1)$$

$$f_1 = \frac{M_1}{N} f_s \quad (2)$$

Where, M_0 , M_1 and N are integers. To maintain continuous phase between any two adjacent symbols, either Q periods of f_0 signal is transmitted to represent “0” or Q periods of f_1 signal is transmitted to represent “1” and Q must be the multiple of the least common multiplier of M_0 and M_1 . Thus, the symbol duration when “0” and “1” is transmitted is given by equation 3 and equation 4 respectively.

$$T_{b0} = \frac{QN}{M_0 f_s} = \frac{QN}{M_0} T_s \quad (3)$$

$$T_{b1} = \frac{QN}{M_1 f_s} = \frac{QN}{M_1} T_s \quad (4)$$

The averaging bit duration is

$$R_b = \frac{2}{T_{b0} + T_{b1}} \quad (5)$$

To clearly demonstrate the effects of N, M0, M1, and Q on f0, f1, T0, T1, and Rb, three possible settings for N, M0, M1, and Q are given in Table 4 as the example settings for the FSK communication system.

Table 4

Example Settings for the FSK Communication System

Parameters	Setting No. 1	Setting No. 2	Setting No. 3
N	22	11	11
M0	9	4	2
M1	11	5	3
Q	99	20	6
f0	18.04 kHz	16.04 kHz	8.02 kHz
f1	22.05 kHz	20.05 kHz	12.03 kHz
T0 in Ts	242	55	33
T1 in Ts	198	44	22
Rb	200.5 b/s	890.9 b/s	1.604 kb/s

Our planned demodulation approach is shown in Figure 16. The timer counter unit adds timer values for Q rising edges of the received signal. We compare the time of Q edges with a threshold to decide whether we received a bit '0' or a bit '1'.

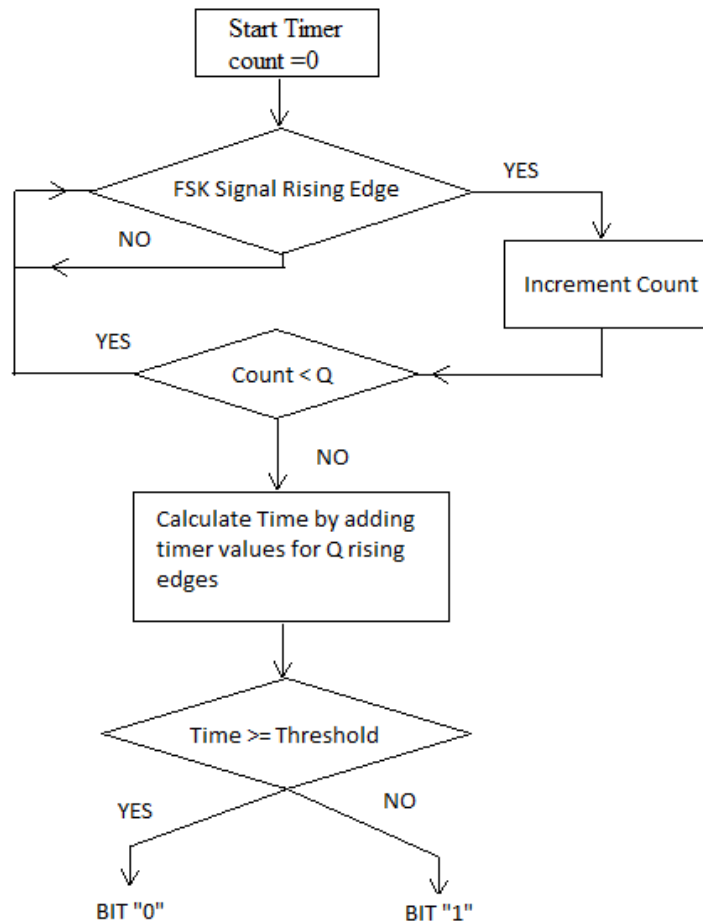

Figure 16. Microcontroller Demodulation Approach

Sensing Prototype

To thoroughly investigate the performance of the novel power harvesting circuit and the related FSK communication system, we proposed a prototype system demonstrating sensing application. The smartphone based sensing prototype architecture is shown in Figure 17.

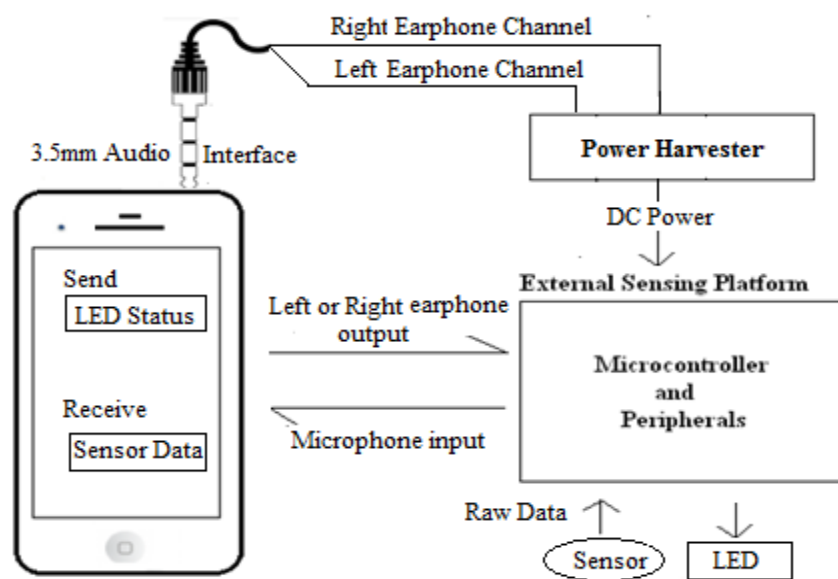

Figure 17. Sensing Prototype Architecture

The system consists of an Android smartphone and an external device built with a microcontroller, an external sensor, and other related components. The prototype system connects the external device with the smartphone through the 3.5mm audio interface. With this connection, the system can implement the following features:

1. Power the external device with both earphone channels of the smartphone: through

harvesting power from a FSK signal.

2. Provide data communication from the microcontroller to the smartphone with the microphone channel of the smartphone: Differential Manchester code is used for modulation.
3. Provide data communication from the smartphone to the microcontroller with one earphone channel of the smartphone: FSK scheme is used for modulation.
4. Display the measurement results of the sensor on the smartphone.
5. Control the outputs of the microcontroller from the smartphone: for example, individually turn on/off a group of LEDs connected to the microcontroller from the smartphone.

The proposed Joint Power Harvesting and communication technology is expected to support Android smartphone sensing applications. The use of double channel power harvester is expected to harvest at least double DC power in comparison to 7.4 mW using a single channel power harvester.

CHAPTER 4

RESULTS AND DISCUSSIONS

Audio Output Power Investigations

The output power of the audio interface with mono channel and stereo channel configurations is investigated under this section. The experimental settings for measuring the power output of the 3.5 mm audio interface with mono channel and the stereo channel configuration are shown in Table 5.

Table 5

Experimental Settings for Measuring the Power Output with Mono and Stereo Channel Configurations

Channel configuration	Mono channel configuration and Stereo channel configuration
Hardware	Android smartphone (ZTE N800 Awe, 2017)
Software	AudioOut App (Android open source project, 2017)
Measuring equipment	Oscilloscope and Multimeter
Output signal	FSK signal with two frequencies points at 16 kHz and 20 kHz
Data Rate	1 kbps
Volume	Maximum
Load	0 to 15 k Ω

With the FSK signal described in Table 5 and for both the mono and the stereo channel configurations, we have measured the output voltage of the 3.5mm audio interface when the load resistance varies from 0 to 15 k Ω . The relation of the output voltage, current, and power of the 3.5 mm audio interface are calculated and depicted in Figure 18 for both the mono and the stereo channel configurations. And, the maximum power output and the corresponding voltage, current and load for the mono and the stereo channel configurations are summarized in Table 6.

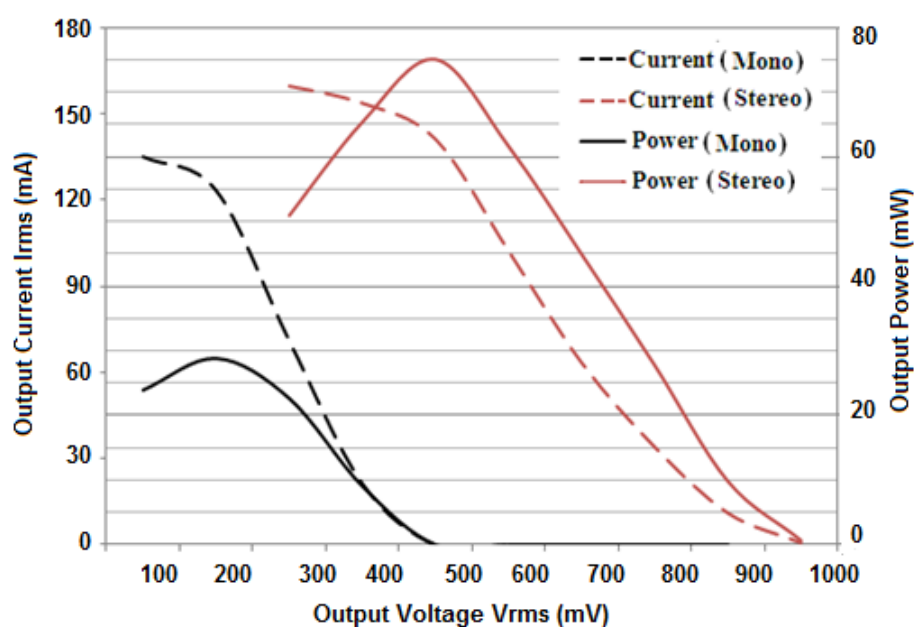

Figure 18. Output Voltage, Current, and Power of the 3.5mm Audio Interface using the Mono and the Stereo Channel Configurations

Table 6

Maximum Power Output and the correspondence Voltage, Current and Load for the Mono and Stereo Channel Configurations

Measurements	Mono channel configuration	Stereo channel configuration
Load	1.9 Ω	3.77 Ω
Maximum power output	28.8 mW	75 mW
Output voltage (rms)	234 mV	532 mV
Output current (rms)	123 mA	141 mA

From Figure18 and Table 6, we can conclude that the stereo channel configuration is a highly efficient approach to harvest power from the audio interface, providing about 2.6 times more power than the mono channel configuration can.

Power Harvester Performance Evaluation

The Power harvesting circuit first boosts the amplitude of the AC signal (i.e. the FSK signal) and then converts the signal into DC to power the external sensing platform. The Power harvester design performance evaluation is conducted using the more efficient stereo channel configuration instead of the mono channel configuration. The experimental setup for the performance evaluation of two power harvester designs are shown in Figure 19 and the experimental settings are shown in Table 7.

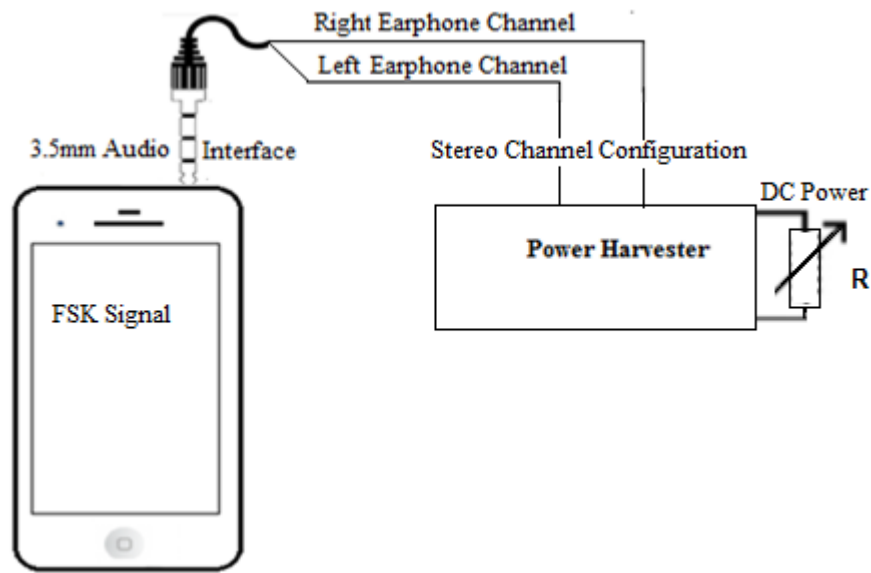

Figure 19. Power Harvester Performance Evaluation using Stereo Channel Configuration

Table 7

Experimental Settings for Performance Evaluation of Power Harvesting Design 1 and FSK Communication.

Smartphone	ZTE N800 (ZTE N800 Awe, 2017)
App	An audio app developed by us
Audio output	Sinusoidal signal or FSK signal
Audio volume	Maximum
DC load	A variable resistor from 0Ω to $1k\Omega$
Measuring equipment	Oscilloscope and Multimeter

Power Harvester Design 1

To evaluate the performance of the proposed power harvester, a testing circuit has been implemented on a breadboard and is shown in Fig. 20.

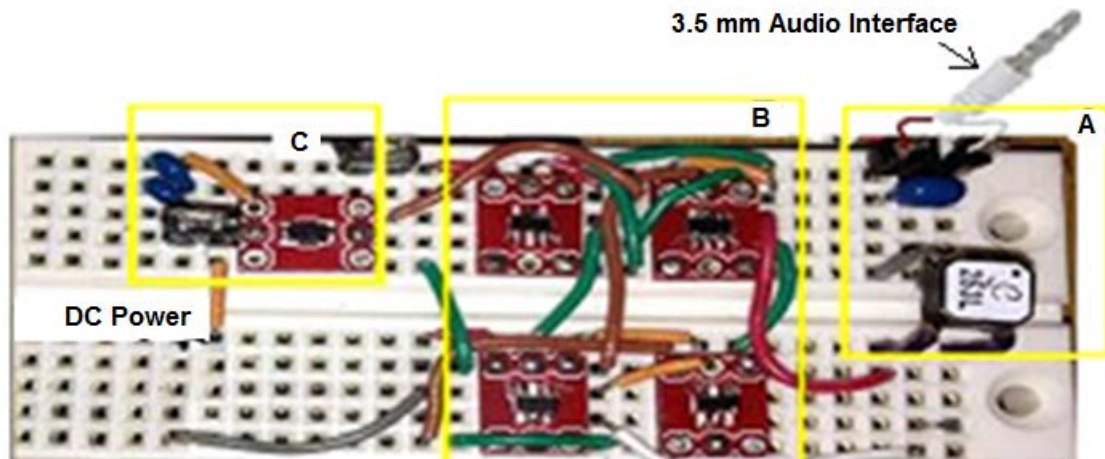

Figure 20. Testing Circuit for Power Harvesting: (A) Step-up Transformer, (B) FET-based Bridge Rectifier, (C) Schottky Diode and Filtering Capacitors

The Eclipse IDE with built-in Android Developer Tools (Kuo et al., 2010) is used to create an audio app that can generate three types of AC signals: a 16 kHz sinusoidal wave, a 20 kHz sinusoidal wave, and an FSK signal with two modulation frequencies at 16 kHz and 20 kHz. To fulfill the energy harvester requirement to use the stereo channel configuration, this audio app also ensures that the signals outputted by the left and the right earphone channels have 180-degree phase difference.

The power harvester performance was tested with the audio channel output of the smartphone being 16 kHz sinusoidal wave, 20 kHz sinusoidal wave, and FSK signal

respectively. The corresponding voltages of the power harvesting circuit at the input of the step-up transformer, the output of the FET-based bridge rectifier, and the DC output are shown with 100 Ω to 1.5 k Ω varying load resistance. When the load resistance is 500 Ω , the power at the DC output achieves its maximum value, and the corresponding measurement results are illustrated in Fig. 20 and summarized in Table 8.

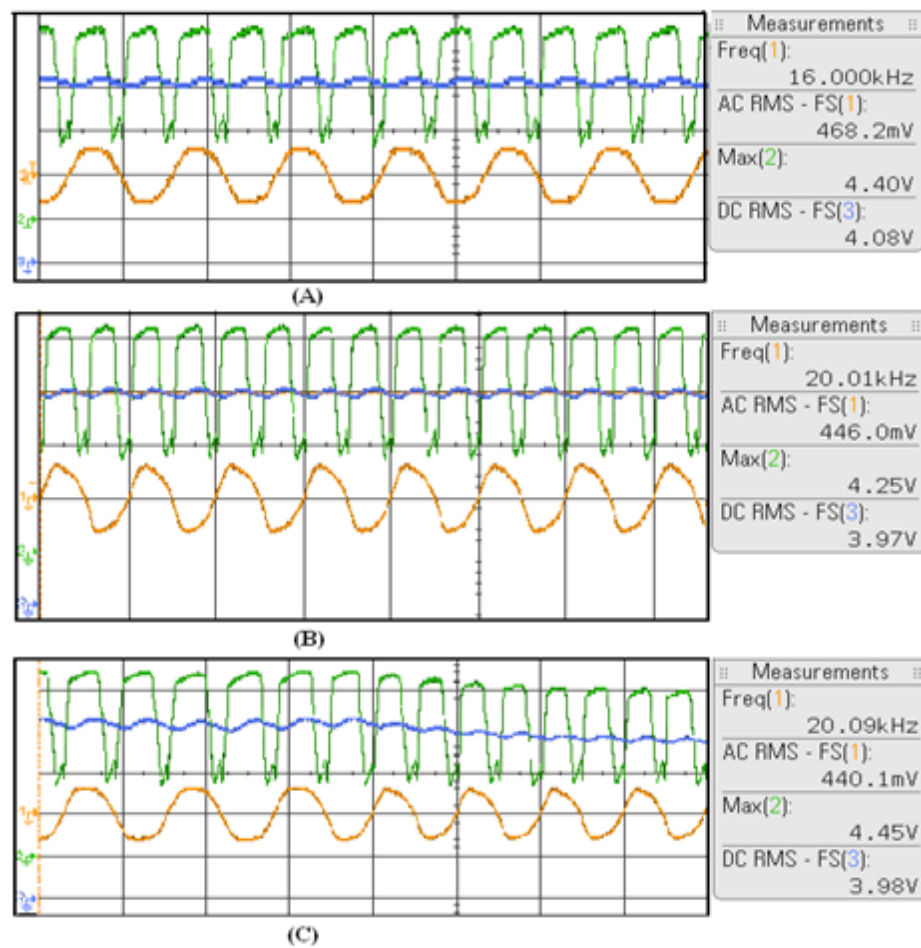

Figure 21. Voltages of the Power Harvesting Circuit using the Mono Channel Configuration with a Load of 500 ohm. AC Signal Type: (A) 16 kHz (B) 20 kHz (C) FSK. Channel 1 (orange): Input of Step-up Transformer. Channel 2 (green): Output of Rectifier. Channel 3 (blue): DC output

Table 8

Measurement Results for the Power Harvesting Circuit using Stereo Channel Configuration with Different Types of AC Signals

AC signal Type	16 kHz	20 kHz	FSK	Units
Channel 1: Input of stepup transformer (rms value)	468	446	440	mV
Channel 2: Output of rectifier (peak value)	4.4	4.25	4.45	V
Channel 3: DC output	4.08	3.97	3.98	V
DC power	33.3	31.5	31.7	mW

From the measurement results, we have the following three observations. First, the type of AC signal has almost no effect on power harvesting. We can harvest almost the same amount of power from an FSK signal as from a sinusoidal wave. Second, even when the power at the DC output achieves its maximum value, which typically means a heavy load, the shape of the FSK signal does not have serious distortion. Thus, we still can demodulate data from the FSK signal without any error. The first and the second conclusions ensure that we can simultaneously harvest power and transfer data with the same earphone channels. The last, but not the least, observation is that the power harvesting circuit using the stereo channel configuration can harvest more than two times the power from the audio interface as compared to that using the mono channel configuration.

But, boosting the voltage of the AC signal with a transformer has quite a few disadvantages. First, because the highest frequency of the AC signal is limited by a half of the sampling frequency of the smartphone, $f_s=44.1$ kHz, either the size and the cost of

the transformer is large, or the efficiency of the power transformation is low. Second, there is limited flexibility to choose the frequency of the AC signal, and hence it is very difficult to increase the data rate for the FSK communication system without reducing the power efficiency of the transformer. For example, the No. 3 setting in Table 1 cannot be used by this power harvesting circuit.

Power Harvester Design 2

The Power harvester design 2 is a novel power harvesting circuit that can generate DC power with enough high voltage without using a transformer. To thoroughly investigate the performance of the novel power harvesting circuit and the related FSK communication system, a prototype circuit for power harvesting has been implemented.

First, by setting the audio output as a sinusoidal signal, the DC power outputs for different values of load resistance are measured when the frequency of the AC signal is respectively set at 1 kHz, 2 kHz, 4 kHz, 8 kHz, 10 kHz, 12 kHz, 14 kHz, 16 kHz, 18 kHz, and 20 kHz. As shown in Figure 22, when the frequency of the AC signal is lower than 4 kHz, the DC power output is substantially lower than when other frequencies are used. The DC power output peaks at a frequency range between 8 kHz and 12 kHz. When the frequency is higher than 12 kHz, DC power output reduces gradually with the increase of the frequency.

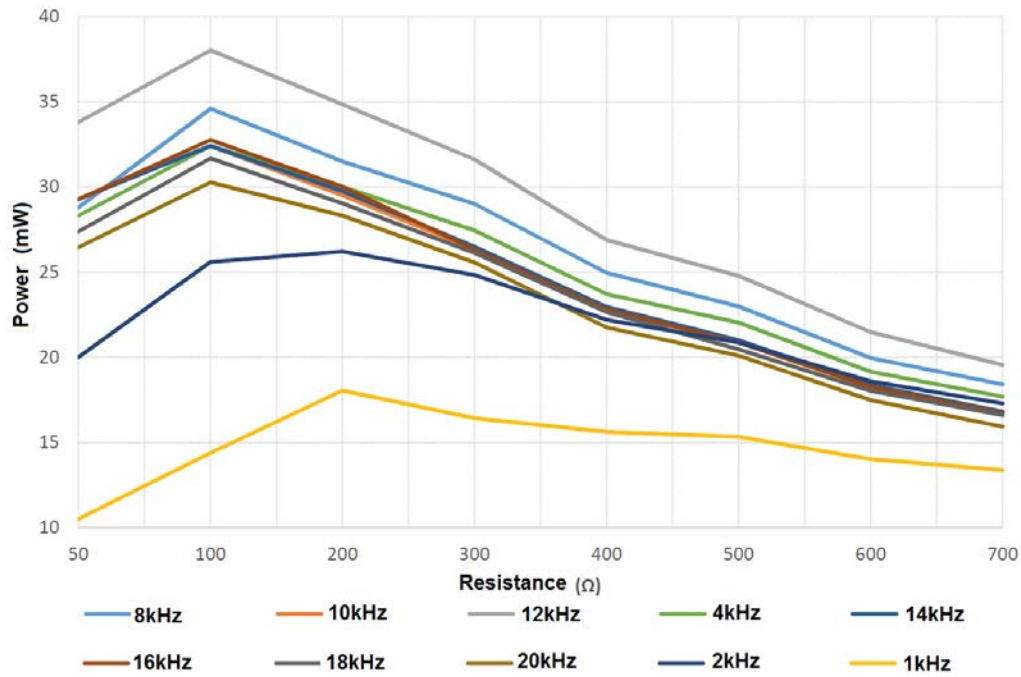

Figure 22. DC Power Output vs. Frequency of the Sinusoidal Signal

Because the measurements with the sinusoidal signal show that the novel power harvesting circuit has the highest DC power output at a frequency range between 8 kHz and 12 kHz, the No. 3 setting in Table 4 is used to generate the FSK signal for power harvesting as well as data communications. The measurement results shows that the circuit can harvest similar amounts of DC power from the FSK signal as from the sinusoidal signal, and the highest output power is 36.3 mW when the load resistance is 100 Ω.

The goal of this research is to develop the Android smartphone powered sensing platform and evaluate its performance in sensing. While designing, the sensing prototype, the power harvesting design needs to be taken in to consideration. To design efficient

Android power harvester, the Quadruple based power harvesting design 2 shows better performance by harvesting 36.3 mW power in comparison to 31.7 mW by power harvesting design 1. Also, Figure 22 shows the quadruple based power harvester can support the higher data rates as shown in No. 3 setting in Table 4. After achieving the desired performance of power harvesting design, we started the implementation of a sensing prototype system for the joint power harvesting and communication technology.

Sensing Prototype

The prototype system uses the power harvester design 2 for implementing smartphone centric ubiquitous sensing. The experimental setup for the sensing platform shown in Figure 23, consists of an Android smartphone (ZTE N800) and an external sensing platform built with a power harvester, a microcontroller (MSP430f1611), a potentiometer sensor, and LEDs. The Audio app displayed on a smartphone provides a user interface to send information to the sensing platform and to display the measurement results received by the sensing platform.

The sensing prototype uses Differential Manchester code to communicate from the sensing platform (microcontroller) to the smartphone over the microphone channel of the smartphone. The information transmitted from the microcontroller (MCU) gets recorded as a sound signal at the microphone input. The phase of the recorded sound may have an 180o degree shift and this phase ambiguity is resolved with proposed differential Manchester codes. The continuous reading from the sensor (potentiometer) attached to the analog port of the microcontroller is encoded as Differential Manchester (DM) coded data stream before transmitting. The encoded data stream from the microcontroller is then

transmitted on the microphone input of a smartphone via an opto-isolator because the reference grounds for sensing platform and smartphone are different. The smartphone decodes the received data stream and the readings are displayed on a smartphone app. With the designed protocol discussed in chapter 3, up to 7.35kb/s, data rate can be achieved from the sensing platform to a smartphone.



Figure 23. Experimental Setup for the Sensing Platform

The data communicates from the smartphone to the sensing platform (microcontroller) with the left earphone channel of the smartphone and uses a novel non-coherent FSK demodulation approach to achieve joint power harvesting and communication technology. The four Led buttons on Audio App can be toggled and the

send button is used to transmit the frame of Led status to the sensing platform via left earphone channel. The four LEDs placed on the sensing platform then display the status of the frame received from smartphone. With an Olimex MSP430f1611 prototype board, we have verified the performance of joint power harvesting and communication technology and the results are in the next section.

Joint Power Harvesting and Communication Technology

To achieve joint power harvesting and communication technology, the proposed non-coherent FSK demodulation uses the timer to measure the duration between two adjacent rising edges of the FSK signal. The timer is driven by a high-speed clock and thus differentiates the two modulation frequencies in a much better way. The No. 3 setting in Table 4 is used to generate the FSK signal for power harvesting as well as data communications. To maintain continuous phase between any two adjacent symbols Q periods of f_0 and f_1 signal is transmitted. The FSK signal frequency is calculated with $f_s = 44.1$ kHz, $N=11$, $M_0=2$, $M_1=3$, $Q=6$ and the calculation results are shown in equation 6 and equation 7.

$$f_0 = \frac{M_0}{N} f_s = 8.02 \text{ kHz} \quad (6)$$

$$f_1 = \frac{M_1}{N} f_s = 12.03 \text{ kHz} \quad (7)$$

The symbol duration when “0” and “1” is transmitted is calculated in equation 8 and equation 9 respectively:

$$T_{b0} = \frac{QN}{M_0 f_s} = \frac{QN}{M_0} T_s = \mathbf{33 T_s} \quad (8)$$

$$T_{b1} = \frac{QN}{M_1 f_s} = \frac{QN}{M_1} T_s = \mathbf{22 T_s} \quad (9)$$

The average bit rate achieved is calculated in equation 10.

$$R_b = \frac{2}{T_{b0} + T_{b1}} = \mathbf{1.604 \text{ kb/s}} \quad (10)$$

In summary, to transmit bit ‘0’, 6 cycles of 8 kHz are transmitted which is 33 sampling point of smartphone and the symbol duration, T_{b0} is 748.3 μs . Similarly, to transmit bit ‘1’, 6 cycles of 12 kHz are transmitted which is 22 sampling point of smartphone and the symbol duration, T_{b1} is 498.87 μs .

To ensure that the joint power harvesting and data communication technology perform efficiently, we have designed a communication protocol for communication from Smartphone to microcontroller.

Communication Protocol

When no data needs to be sent from the smartphone to the microcontroller, the smartphone keeps sending “0” and “1” alternatively on its left and right earphone channel to allow continuous power harvesting; when the smartphone needs to send data, it will send “00” as the starting bits of the frame, which is followed by a byte of data and a parity bit. If the smartphone needs to send another byte after the previous byte, it will duplicate the parity bit of the previous byte as the starting bit, and then send a byte of data and a parity bit. If no more data needs to be sent, a bit that is opposite to the last parity bit is sent to resume the pattern of sending ‘0’ and ‘1’ alternatively.

Power Harvesting

The newly proposed power harvesting technology uses the FSK signal to harvest DC power and the related results are shown in Fig. 24 and Table 9.

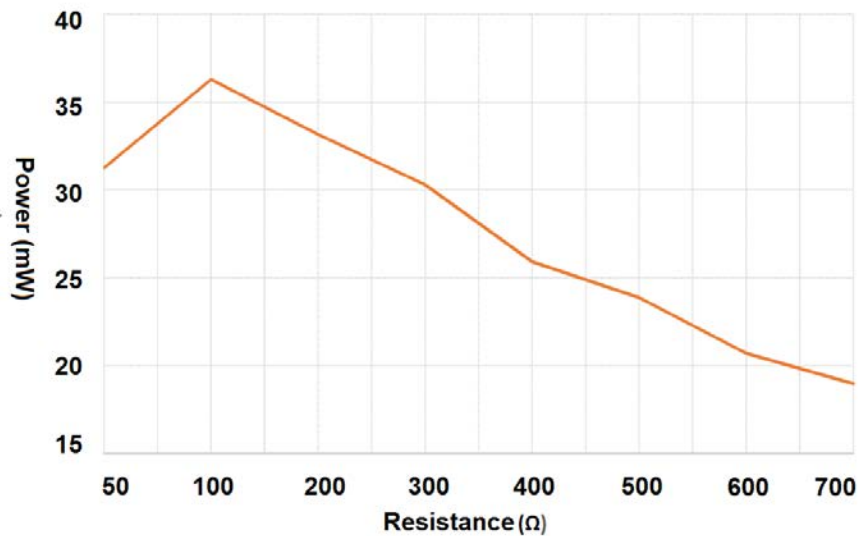

Figure 24. DC Power Output for the FSK Signal

Table 9

Measurement Results for Novel Power Harvesting Circuit

Load Resistance (Ω)	DC voltage (V)	DC current (mA)	DC power (mW)
50	1.25	25.0	31.1
100	1.91	19.1	36.3
200	2.58	12.9	33.2
300	3.02	10.1	30.3
400	3.22	8.05	25.9
500	3.46	6.91	23.9
600	3.53	5.88	20.7
700	3.64	5.21	19.0

The results of harvesting circuit in Table 9 shows that, the power harvesting circuit can provide up to 20 mA DC current if the power supply voltage for the external sensing platform is 1.8 V, and 10 mA DC current if the power supply voltage is 3 V. The highest DC power harvested is 36.3 mW for load resistance of 100 Ω .

In previous studies on several popular smartphone sensing platforms, the available audio channel output power varied for different smartphones. The maximum power available from an Android smartphone is far below the maximum power output of the iPhone and thus the Hijack device doesn't support Android smartphones. (Silicon Labs, 2017).

In general, the power harvested above 30 mW for an operating voltage of 2 V is sufficient to support low power sensing applications and the designed power harvesting circuit harvested 36.3 mW DC output power. The TI MSP430F1611 microcontroller used in the sensing platform belongs to an ultralow power family with one active mode and five software selectable low-power modes of operation. While running in active mode, the supply voltage of the controller ranges from 1.8 V to 3.6 V and draws a mere 0.7 mA at 1.8 V (TI MSP430 Datasheet, 2017); leaving sufficient power to support a variety of sensors.

From the measurement results and sensing prototype performance, we can state that the prototype system is harvesting enough power to support low power Android smartphone sensing applications.

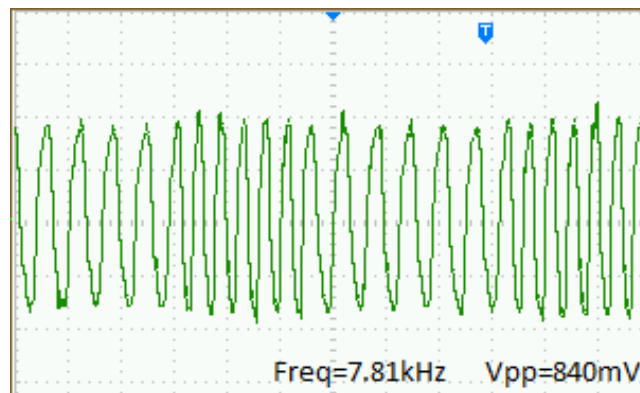

Figure 25. FSK Signal Obtained between the Left Earphone Channel and the Ground

As shown in Figure. 25, even when the load resistance is 100 Ω , i.e. the harvesting circuit has the highest DC power output, almost no distortion is observed on the rising

edge of the FSK signal of left earphone channel. Thus, extensive demodulation tests show that we can achieve a reliable error-free demodulation for the designed sensing prototype.

Discussion

The smartphone sensing platform provides a universal data interface and the hardware can work with various types of smartphones. The software design is easy to change for smartphone working with different operating systems. In this dissertation, the performance of the smartphone sensing platform is tested with Android smartphones.

The proposed technology employs the stereo channel configuration to harvest power between the right and left earphone channels. The newly designed power harvesting circuit using the Quadruple circuit has successfully omitted the limitations of the transformer based power harvester. The Quadruple based power harvesting circuit is independent of the frequency of the audio output signal; the No. 3 setting in Table 1 increased the data rate for the FSK communication system without affecting the DC power output.

Circuit measurements show that by coherently harvesting power from both earphone channels, the proposed technology can extract more than two times the power as from one earphone channel. Meanwhile, circuit measurements also show that power harvesting will not cause serious distortion on the FSK signal and hence the data transferred from a smartphone to external sensors can be recovered without any error.

The sensing prototype using Olimex MSP430f1611 prototype board demonstrated that even with a heavy load, the newly developed timer-based demodulation approach can achieve a reliable error-free performance on demodulating the FSK signal.

CHAPTER 5

CONCLUSION AND FUTURE RECOMMENDATIONS

Smartphone based ubiquitous sensing platforms have revolutionized many sectors of our economy, including business, healthcare, social networks, environmental monitoring, and transportation. Chapter 1 introduces the wide applicability and popularity of smartphones and the emergence of a whole new area of research for smartphone peripherals to facilitate more sensing applications. This study aims to build an Android smartphone-powered sensing platform that leverages the audio jack of Android smartphones to power and to establish data communication. Chapter 2 explores the related literature in the field of smartphone peripherals and states the limitations of existing smartphone powered sensing platforms; they are either not supporting Android smartphones or address limited sensing applications. Chapter 3 describes the methodology used in this research study to design the Android smartphone powered sensing platform to support sensing applications. This chapter explores different design aspects of sensing platforms with an aim to design sensing prototype for Android Smartphone. Based on the results obtained in chapter 4, the Sensing prototype successfully implemented the joint power harvesting and communication technology. This chapter closes with a discussion on the performance of the prototype system for the joint power harvesting and communication technology.

Conclusion

The pervasiveness and computing capability of smartphones, in addition to communication, make them an ideal user interface for ubiquitous sensing applications. In this research, based on FSK modulation scheme, we have proposed a joint power harvesting and communication technology that can simultaneously harvest power and transfer data with the same earphone channels. By setting the AC signals outputted by the right and left earphone channels to have 180-degree phase difference, the newly proposed technology employs the stereo channel configuration to harvest power between the right and left earphone channels. Circuit measurements show that by coherently harvesting power from both earphone channels, the proposed technology can extract more than two times the power as from one earphone channel. This enhanced performance of the power harvester design will be a solution to different smartphone manufactures whose maximum available power is considerably low in comparison to iPhone.

The circuit measurements also show that power harvesting will not cause serious distortion on the FSK signal and hence the data transferred from a smartphone to external sensors can be recovered without any error. Finally, with an Olimex MSP430f1611 prototype board, we have verified that even with a heavy load, the newly developed timer-based demodulation approach can achieve a reliable error-free performance on demodulating the FSK signal.

In this growing economy, smartphones are becoming ever more affordable and are an indispensable part of our daily life. The smartphone powered sensing platforms are needed in applications where sensing platforms are equipped with low power sensors to

achieve low cost, flexibility and mobility with a possible tradeoff of speed and security. With this enhanced performance of the power harvester design, the joint power harvesting and communication technology results in a universal hardware that can support most smartphone centric ubiquitous sensing applications. The software design needs to be changed for different smartphones based on the smartphone operating system. We evaluated the performance of the smartphone sensing platform with Android smartphone.

Future Recommendation

While this dissertation has demonstrated the universal smartphone sensing platform using joint power harvesting and communication technology, many opportunities for extending the scope of this dissertation remain. This section presents some of these directions.

There is some scope of improvement in the efficiency of the Power Harvester. The sensing platform can leverage the Microphone Bias voltage to provide additional useful power as needed for different sensing applications. This is to increase throughput by supporting more number of external sensors.

The developed prototype can be used with most Android smartphones and iPhones. The iPhone audio output power is considerably higher than Android and so the performance of the Power Harvester is expected to be even better with a higher DC output power. To avoid the interface issues and with Sensing platform it might be better to design a portable power harvester from Android to iPhone with not much difference in the performance.

The data modulation schemes and communication protocols designed between smartphone and sensing platform attains satisfying data rates which has potential to support most smartphone based sensing applications. There is still scope to test and redefine the data modulation schemes and communication protocols for achieving higher data rates and lower bit error rate.

This study is not analyzing the power dissipation of smartphone battery while attached to external sensing platform. There is scope of further research in this direction to study the performance of Power Harvester in sustaining the battery life of the smartphone.

REFERENCES

- Android open source project. (2017). Retrieved from <https://developer.android.com/sdk/index.html?hl=i>
- Beal, V. (2011, August 10). *Mobile Operating Systems (Mobile OS) Explained*. Retrieved from Webopedia:
http://www.webopedia.com/DidYouKnow/Hardware_Software/mobile-operating-systems-mobile-os-explained.html
- Biru, A., Rotondi, D., & Minerva, R. (2015, May 13). *Definition of the Internet of Things*. Retrieved from iot.ieee.org:
https://iot.ieee.org/images/files/pdf/IEEE_IoT_Towards_Definition_Internet_of_Things_Issue1_14MAY15.pdf
- Black, J., Koch, F., Sonenberg, L., Scheepers, R., Khandoker, A., Charry, E., . . . Soe, N. L. (2009). Mobile solutions for front-line health workers in developing countries. *Proceedings of 11th International Conference on e-Health Networking, Applications and Services*, 89-93.
- Boxall, A. (2015 , June 6). *The number of smartphone users in the world is expected to reach a giant 6.1 billion by 2020*. Retrieved from <http://www.digitaltrends.com/mobile/smartphone-users-number-6-1-billion-by-2020/>
- Breathometer*. (2017, April). Retrieved 4 19, 2017, from [Breathometer](http://www.breathometer.com):
<http://www.breathometer.com>
- Breathometer review* . (2014, August 20). Retrieved from [JerseyKids](http://jerseykids.net/2014/08/20/3740/):
<http://jerseykids.net/2014/08/20/3740/>
- Campbell, A., & Choudhury, T. (2012). *From Smart to Cognitive Phones*. Retrieved from Cornell:
http://www.cs.cornell.edu/~tanzeem/pubs/IEEE_Pervasive_CognitivePhones.pdf
- Data Encoding Techniques*. (2017, May). Retrieved from Tutorialspoint:
https://www.tutorialspoint.com/digital_communication/digital_communication_data_encoding_techniques.htm
- Future Electronics*. (2017, January). Retrieved April 5, 2017, from <https://www.futureelectronics.com/en/Microcontrollers/microcontrollers.aspx>
- iDevices Thermostat*. (2017, May). Retrieved 2017, from Apple:
<http://www.apple.com/shop/product/HL1Z2LL/A/idevices->

thermostat?fnode=3f9ea52da61893e866c66fb1be7a122e5a6f874772e4c80fdef355335b75f2b2169a8456dbf8578ca015d1f220243b39dc7cb58998978907134f1254e4067965233b5ce970e98a4909965b1db4dc58e0be4091cd279bb8863a1003906

- Intro to Sensors.* (2017). Retrieved from NYU Engineering:
<http://engineering.nyu.edu/gk12/amps-cbri/pdf/Intro%20to%20Sensors.pdf>
- iTunes. (2017, January). *iTunes*. Retrieved March 29, 2017, from App Store:
<https://itunes.apple.com/app/window/id855129246?mt=8>
- JDC Electronics. (2016, January). Retrieved March 29, 2017, from
<http://windoo.ch/specifications>
- Kuo, Y.-S., Schmid, T., & Dutta, P. (2010). Hijacking Power and Bandwidth from the Mobile Phone's Audio Interface. *Proceedings of First ACM Annual Symposium on Computing for Development*. London.
- Malik, O. (2009, December 1). *Jack Dorsey on Square, How It Works & Why It Disrupts*. Retrieved from Gigaom: <https://gigaom.com/2009/12/01/jack-dorsey-on-square-why-it-is-disruptive/>
- Middlestead, R. W. (2017). FREQUENCY SHIFT KEYING (FSK) MODULATION, DEMODULATION, AND PERFORMANCE. In *Digital Communications with Emphasis on Data Modems* (pp. 207-225). John Wiley & Sons, Inc.
- Mint.* (n.d.). Retrieved April 19, 2017, from Breathometer:
<https://www.breathometer.com/mint/>
- Mobile/Tablet Operating System Market Share.* (2017). Retrieved from NET Market Share: <https://www.netmarketshare.com/operating-system-market-share.aspx?qprid=8&qpcustomd=1&qptimeframe=Y>
- Nanobionics.* (2017, January). Retrieved from Mobosens:
<http://nanobionics.mntl.illinois.edu/mobosens>
- Sampling Frequency.* (2004, April 15). Retrieved from ppgb:
http://www.fon.hum.uva.nl/praat/manual/sampling_frequency.html
- Seeman, M. D., Sanders, S. R., & Rabaey, J. R. (2007). An ultra-low-power power management IC for wireless sensor nodes. *Proc. 29th IEEE Custom Integrated Circuits Conference* (pp. 567-570.). Piscataway, NJ: IEEE Press.
- Sensor Overview.* (2017, May). Retrieved 2017, from Android:
https://developer.android.com/guide/topics/sensors/sensors_overview.html

- Silicon Labs.* (2017). Retrieved from Connect the EFM32 with a Smart Phone through the Audio Jack:
<http://www.silabs.com/Support%20Documents/TechnicalDocs/AN005>
- Skywatch Windoo.* (2017, April). Retrieved March 29, 2017, from Google Play:
<https://play.google.com/store/apps/details?id=ch.skywatch.windoo>
- Smartphone Users Worldwide Will Total 1.75 Billion in 2014.* (2014, January 16). Retrieved from [http://www.emarketer.com/Article/Smartphone -Users-](http://www.emarketer.com/Article/Smartphone-Users-)
- Smith, S. W. (1997). The Sampling Theorem. In *Digital Signal Processing*. San Diego: California Technical Pub.
- Square.* (2017, January). Retrieved 4 19, 2017, from Squareup:
<https://squareup.com/reader>
- TI MSP430 Datasheet.* (2017, April). Retrieved from Texas Instrument:
<http://www.ti.com/lit/ds/symlink/msp430f1612.pdf>
- Verma, S., Robinson, A., & Dutta, P. (2012, November). AudioDAQ: Turning the Mobile Phone's Ubiquitous Headset Port into a Universal Data Acquisition Interface. *Sensys ACM*.
- Windoo.* (2017, April). Retrieved 4 19, 2017, from Skywatch Windoo:
<http://www.windoo.ch>
- ZTE N800 Awe.* (2017, April). Retrieved 2017, from PDADB.net:
http://pdadb.net/index.php?m=specs&id=4982&c=zte_n800_awe

APPENDIX

TI-MSP430 F1611 DATASHEET

- Low Supply Voltage Range: 1.8 V to 3.6 V
- Ultralow Power Consumption
 - Active Mode: 330 μ A at 1 MHz, 2.2V
 - Standby Mode: 1.1 μ A
 - Off Mode (RAM Retention): 0.2 μ A
- Five Power-Saving Modes
- Wake-Up From Standby Mode in Less Than 6 μ s
- 16-Bit RISC Architecture, 125-ns Instruction Cycle Time
- Three-Channel Internal DMA 12-Bit Analog-to-Digital (A/D) Converter With Internal Reference, Sample-and-Hold, and Autoscan Feature
- Dual 12-Bit Digital-to-Analog (D/A) Converters With Synchronization
- 16-Bit Timer_A With Three Capture/Compare Registers
- 16-Bit Timer_B With Three or Seven Capture/Compare-With-Shadow Registers
- On-Chip Comparator Serial Communication Interface (USART0),
- Functions as Asynchronous UART or Synchronous SPI or I2CTM Interface
- Serial Communication Interface (USART1), Functions as Asynchronous UART or Synchronous SPI Interface
- Supply Voltage Supervisor/Monitor With Programmable Level Detection
- Brownout Detector
- Bootstrap Loader
- Serial Onboard Programming, No External Programming Voltage Needed, Programmable Code Protection by Security Fuse
- Family Members Include
 - MSP430F1611
 - 48KB+256B Flash Memory
 - 10KB RAM
- Available in 64-Pin QFP Package (PM) and 64-Pin QFN Package (RTD)
- For Complete Module Descriptions, See the MSP430x1xx Family User's Guide, Literature Number SLAU049

Description

The Texas Instruments MSP430 family of ultralow power microcontrollers consist of several devices featuring different sets of peripherals targeted for various applications.

The architecture, combined with five low power modes is optimized to achieve extended battery life in portable measurement applications. The device features a powerful 16-bit RISC CPU, 16-bit registers, and constant generators that contribute to maximum code efficiency. The digitally controlled oscillator (DCO) allows wake-up from low-power modes to active mode in less than 6 μ s.

The MSP430F15x/16x/161x series are microcontroller configurations with two built-in 16-bit timers, a fast 12-bit A/D converter, dual 12-bit D/A converter, one or two universal serial synchronous/asynchronous communication interfaces (USART), I2C, DMA, and 48 I/O pins. In addition, the MSP430F161x series offers extended RAM addressing for memory-intensive applications and large C-stack requirements. Typical applications include sensor systems, industrial control applications, hand-held meters, etc.

Development Tool Support

All MSP430 microcontrollers include an Embedded Emulation Module (EEM) allowing advanced debugging and programming through easy to use development tools.

Recommended hardware options include the following:

Debugging and Programming Interface

- MSP-FET430UIF (USB)
- MSP-FET430PIF (Parallel Port)

Debugging and Programming Interface with Target Board

- MSP-FET430U64 (PM package)

Standalone Target Board

- MSP-TS430PM64 (PM package)

Production Programmer

- MSP-GANG430

Pin Designation MSP430F1611

PM, RTD PACKAGE
(TOP VIEW)

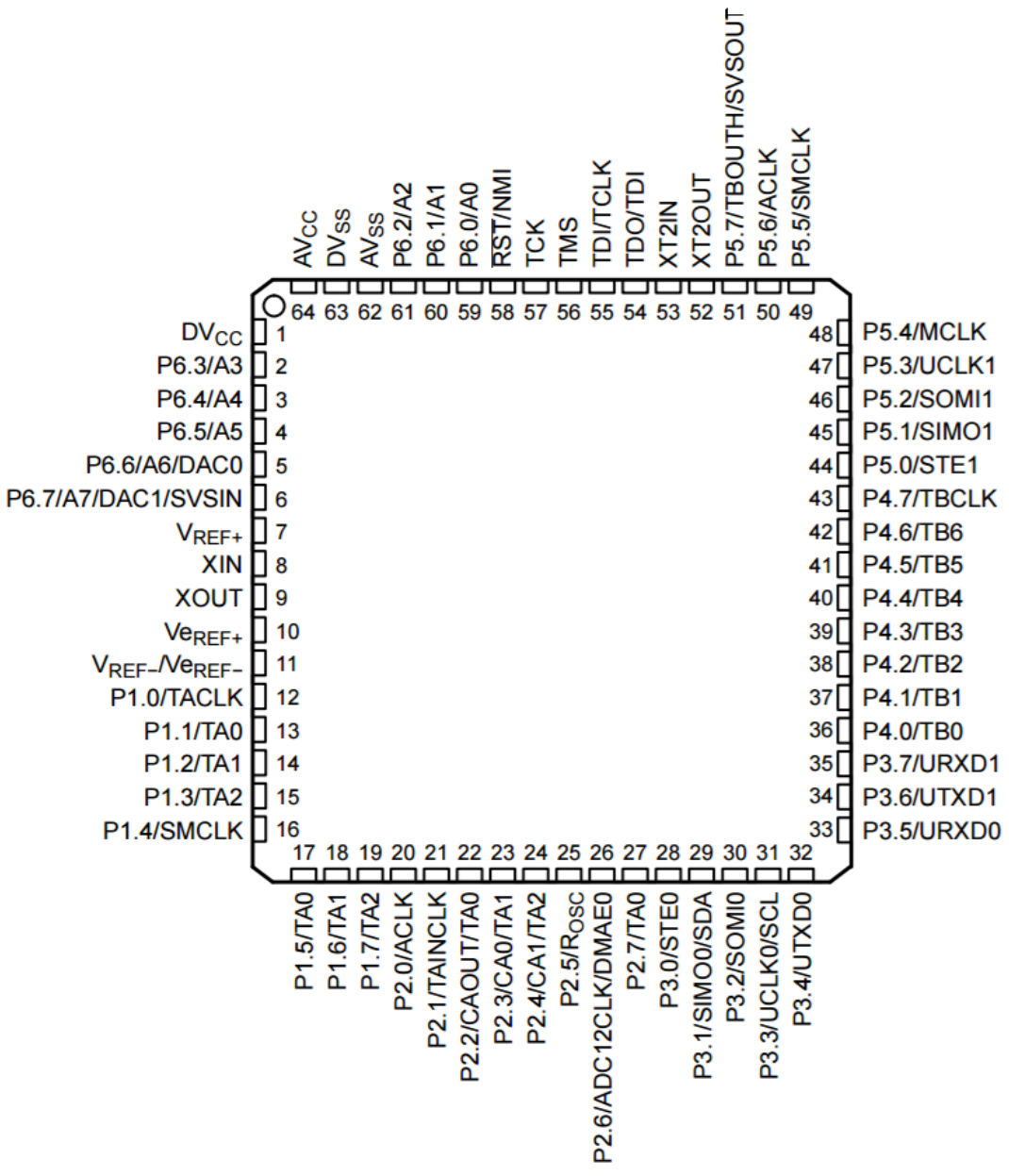

absolute maximum ratings over operating free-air temperature (unless otherwise noted) †

Voltage applied at VCC to VSS	-0.3 V to 4.1 V
Voltage applied to any pin (see Note)	-0.3 V to VCC + 0.3 V
Diode current at any device terminal	±2 mA
Storage temperature, Tstg: Unprogrammed device	-55°C to 150°C
Programmed device	-55°C to 85°C

NOTE: All voltages referenced to VSS. The JTAG fuse-blow voltage, VFB, is allowed to exceed the absolute maximum rating. The voltage is applied to the TDI/TCLK pin when blowing the JTAG fuse.

Recommended operating conditions

	MIN	NOM	MAX	Unit
Supply voltage during program execution, VCC (AVCC = DVCC = VCC)	1.8		3.6	V
Supply voltage during flash memory programming, VCC (AVCC = DVCC = VCC)	2.7		3.6	V
Operating free-air temperature range, TA	-40		85	°C
LFXT1 crystal frequency, f(LFXT1)	Watch crystal	32.768		kHz
	Ceramic resonator	450	8000	kHz
	Crystal	1000	8000	kHz
XT2 crystal frequency f Ceramic resonator 450 8000 XT2 crystal frequency, f(XT2)	450		8000	kHz
	1000		8000	kHz
Processor frequency (signal MCLK), f(System)	DC		4.15	MHz
	DC		8	MHz