

Proceedings of the Iowa Academy of Science

Volume 47 | Annual Issue

Article 29

1940

The Semi-Micro Adaption of the Iowa System of Qualitative Analysis

Lothrop Smith
State University of Iowa

Reuben E. Peterson
State University of Iowa

Copyright © Copyright 1940 by the Iowa Academy of Science, Inc.
Follow this and additional works at: <https://scholarworks.uni.edu/pias>

Recommended Citation

Smith, Lothrop and Peterson, Reuben E. (1940) "The Semi-Micro Adaption of the Iowa System of Qualitative Analysis," *Proceedings of the Iowa Academy of Science*: Vol. 47: No. 1 , Article 29.
Available at: <https://scholarworks.uni.edu/pias/vol47/iss1/29>

This Research is brought to you for free and open access by UNI ScholarWorks. It has been accepted for inclusion in Proceedings of the Iowa Academy of Science by an authorized editor of UNI ScholarWorks. For more information, please contact scholarworks@uni.edu.

THE SEMI-MICRO ADAPTATION OF THE IOWA SYSTEM OF QUALITATIVE ANALYSIS

LOTHROP SMITH AND REUBEN E. PETERSON

During the last few years much effort has been expended in attempts to develop apparatus and special techniques for the analysis of small quantities of material. These procedures can be divided into two classes, the micro and the semi-micro.

Micro analysis deals with samples up to or about 3-5 milligrams. This micro method consumes much less time, requires smaller quantities of reagents, requires much less of the unknown and in other ways proves superior to macro analysis. However, strict micro analysis often requires the use of a microscope and other delicate pieces of apparatus, as well as a knowledge of chemistry possessed by few of those enrolled in the elementary course of qualitative analysis. It is therefore not applicable to the general course in qualitative analysis.

To meet this need for a method which is applicable to elementary classes, semi-micro methods of analysis are being developed. Semi-micro qualitative analysis deals with samples about one-tenth to one twenty-fifth as large as macro samples. In other words, the sample contains from 20 to 40 milligrams of materials to be analyzed for. It requires some special but inexpensive apparatus and some techniques peculiar to semi-micro analysis.

In semi-micro analysis most reactions are carried out in centrifuge tubes. Reagents are kept in dropping bottles, which as a rule are equipped with rubber bulbs. These are convenient because the quantity of reagent added is measured by the number of drops. Separation of the precipitate is effected by centrifuging the mixture. The precipitate settles to the bottom and the filtrate can, as a rule, be poured off, leaving the precipitate undisturbed. Sulfur does not settle in all cases and has to be removed by other means. Since any attempt to boil a mixture in a centrifuge tube is hazardous, the boiling of a mixture or solution is done in a steam or water bath. A solution is usually evaporated by heating it in a crucible, either on a steam bath or very cautiously in the flame of a micro burner. Baking of a precipitate is done in the direct flame.

A semi-micro adaptation of the Iowa System of Qualitative Analysis has been worked out. The problem was attacked by

making a proportionate reduction in the size of the sample and the amounts of the reagents added. A reduction ratio of 1 milliliter to 2 drops was used and if the procedure thus modified gave satisfactory results, it was adopted. Contrary to expectations, there were very few instances where any further modification was found necessary. Those that were found necessary are discussed in later paragraphs.

Figure 1 is a flow sheet of the Iowa System of Qualitative Analysis, as developed by Dr. Jacob Cornog of the State University of Iowa, showing the general outline and group reagents.

Figure 2 shows the chloride group after the adaption to the semi-micro proportions. No modification, other than the proportionate reduction, was found necessary in this group.

Group Separations

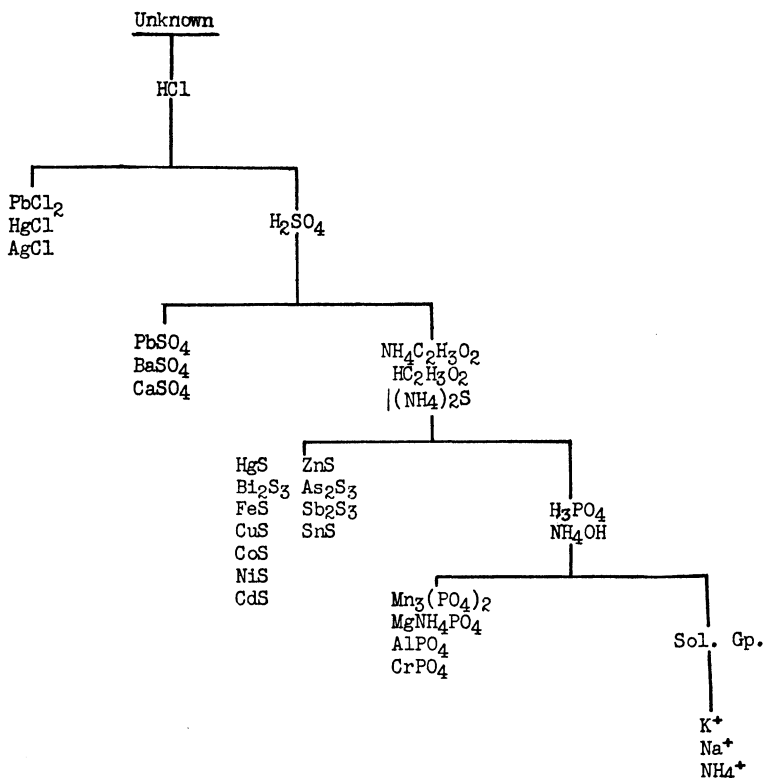

Fig. 1

Figure 3 is a flow sheet of the sulfate group. A modification, other than the reduction in quantities, was made in the final test for lead. Most of the lead has been removed by the chloride group precipitation and in semi-micro analysis the removal as a chloride seems to be much better than in macro analysis. The precipitation and the identification of lead as lead chromate was found to be more sensitive than the precipitation as lead sulfate and is therefore used as the final test. The macro procedure uses the formation of lead sulfate as the final test.

Another modification which seemed desirable is in the method of separation of copper, cobalt, nickel and cadmium from manga-

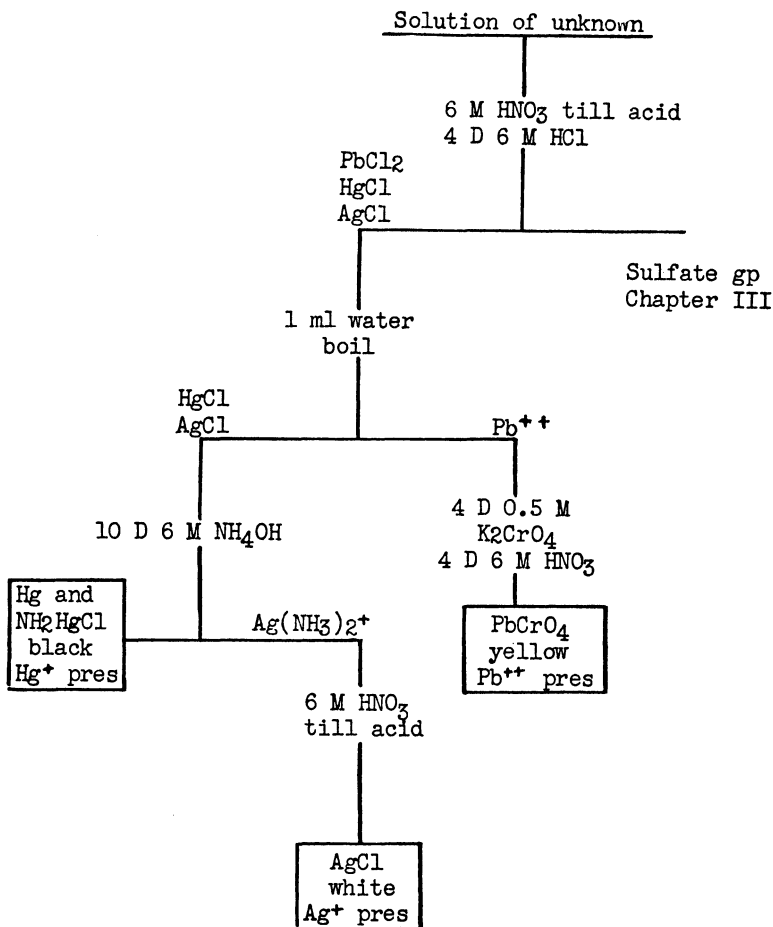

Fig. 2

nese, bismuth and iron. The macro procedure calls for the precipitation of the above mentioned cations as the hydroxides and the subsequent dissolving of the copper, cobalt, cadmium, and nickel hydroxides by the addition of acetic acid and water. This procedure does not give a complete separation when using semi-micro proportions, probably because it is not practical to dilute to the same

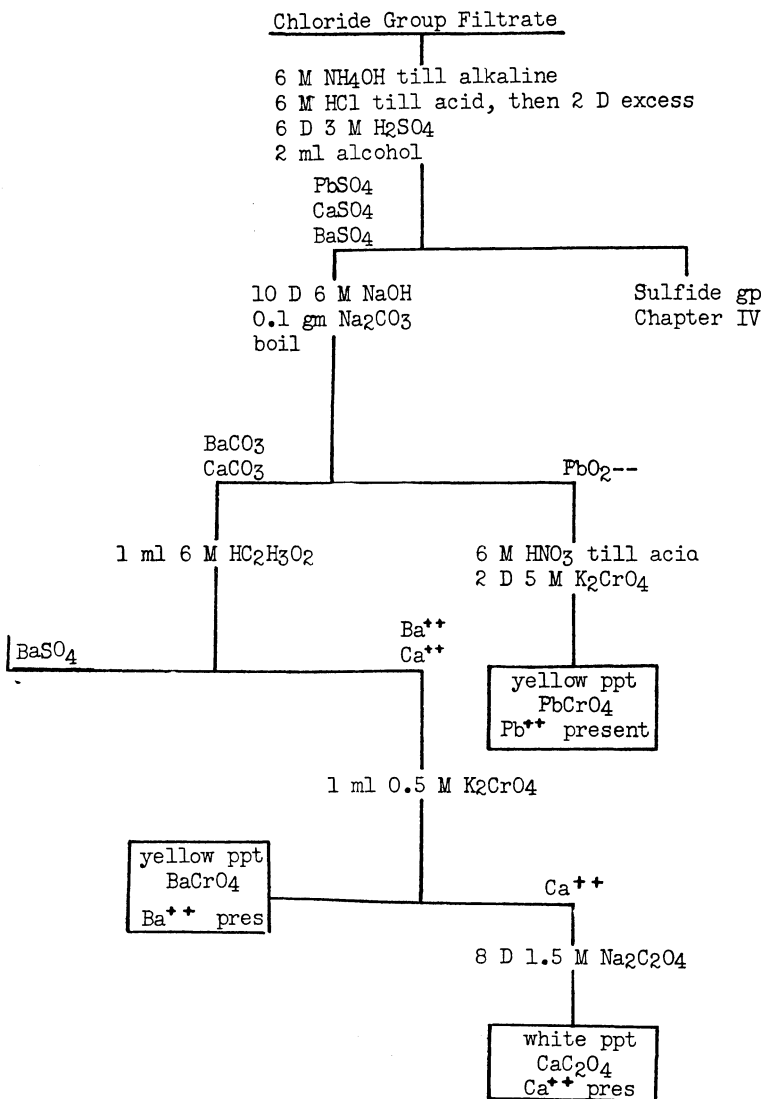

Fig. 3

proportions. The procedure shown in Figure 5A was found to give a complete separation.

The method of detection of the sulfide and carbonate ions necessarily requires a modification. The detection of the sulfide ion will be discussed briefly. A small amount of the unknown and several grains of zinc are placed in a centrifuge tube. Hydrochloric acid is added and some filter paper impregnated with lead acetate solution is placed over the mouth of the centrifuge tube. A blackening

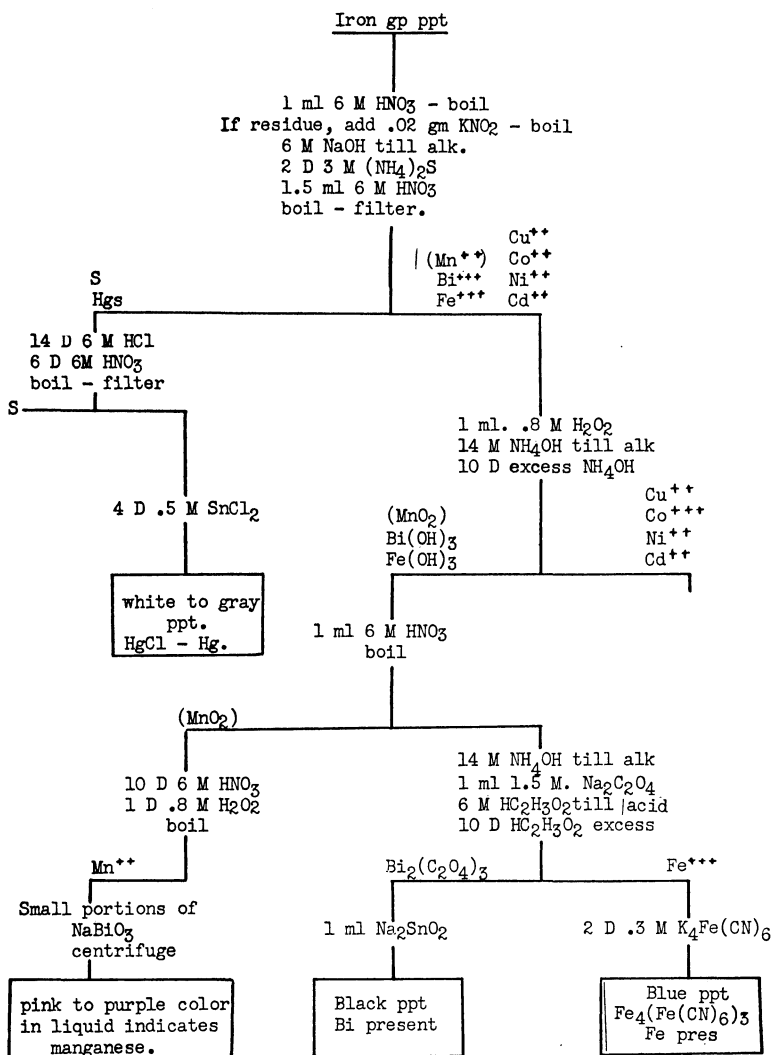

Fig. 5A

of the filter paper, due to the formation of lead sulfide, indicates the presence of sulfide ion. The zinc added reacts with the acid to liberate hydrogen which will drive the hydrogen sulfide gas to the mouth of the tube.

REFERENCES

1. CORNOG, J. "The Iowa System of Qualitative Chemical Analysis," Jacob Cornog, Iowa City, Iowa. 1937. Ed. 4.
2. CORNOG AND SMITH, L. *Proc. Iowa Acad. Sci.* 42, 106. (1935).
3. ARTHUR AND SMITH. "Semi-Micro Qualitative Analysis." McGraw-Hill Book Company, Inc. New York. 1938. Ed. 1.
4. ENGELDER, DUNKELBERGER, AND SCHILLER. "Semi-Micro Qualitative Analysis." John Wiley and Sons, Inc. New York. 1936. Ed. 1.
5. SIMON AND REEDY. *Trans. Ill. Acad. Sci.* 32 (Dec. 1939).

DEPARTMENT OF CHEMISTRY,
STATE UNIVERSITY OF IOWA,
IOWA CITY, IOWA.