

1974

An Improved Holding Chamber for the Measurement of Oxygen Consumption in Mice

Kenneth M. Cook
Coe College

Thomas J. Doody
Coe College

Copyright ©1974 Iowa Academy of Science, Inc.

Follow this and additional works at: <https://scholarworks.uni.edu/pias>

Recommended Citation

Cook, Kenneth M. and Doody, Thomas J. (1974) "An Improved Holding Chamber for the Measurement of Oxygen Consumption in Mice," *Proceedings of the Iowa Academy of Science*, 81(2), 72-72.

Available at: <https://scholarworks.uni.edu/pias/vol81/iss2/9>

This Research is brought to you for free and open access by the Iowa Academy of Science at UNI ScholarWorks. It has been accepted for inclusion in Proceedings of the Iowa Academy of Science by an authorized editor of UNI ScholarWorks. For more information, please contact scholarworks@uni.edu.

An Improved Holding Chamber for the Measurement of Oxygen Consumption in Mice

KENNETH M. COOK¹ and THOMAS J. DOODY²

COOK, KENNETH M. (Biology Department, Coe College, Cedar Rapids, Iowa 52402). An Improved Holding Chamber for the Measurement of Oxygen Consumption in Mice. *Proc. Iowa Acad. Sci.* 81(2): 72, 1974.

An apparatus is described which has been useful in classroom

demonstrations and for research in metabolic studies of mice. The unique feature of this modification of basic metabolators is a standard taper ground glass joint.

INDEX DESCRIPTORS: Metabolism, Mice, Oxygen.

Investigators have long had an interest in the oxygen requirements of various species of small mammals under basal conditions and various stages of activity. The literature is replete with modifications of a basic design for the measurement of oxygen consumption in small animals. In reviewing the literature, concern was noted about the physical activity

of mice and therefore it was decided to construct still another modification which would discourage such activity and yet provide ample air for the animals. A tall glass cylinder with a small base was adopted for use since it restricted movement basically to grooming. Climbing is impossible in the apparatus and animals soon settle down to grooming, resting and sleeping.

The primary feature of the glass cylinder construction as illustrated in Figure 1 is a 71/60 standard taper ground glass joint greased lightly with high vacuum lubricant.

Three 18 mm ports positioned on the top of the cylinder are used for the inlet and outlet of air and a thermometer or thermistor. Thin layered rubber tubing over the thermometer and stainless steel air tubes covered by thicker rubber tubing between glass and glass or glass and metal ensure tight connections. The total volume of the cylinder, as measured by water displacement, is 630 cc. Approximately 70 cc of this is displaced by a layer of about 3/4" of soda lime for carbon dioxide absorption during test runs. Calcium chloride may be used as a desiccant.

Accessory equipment is a kymograph and a research air tambour with an ink writing pen attached. The method and calculations of D'Amour *et al.* (1965) are used. That the apparatus and method used have been satisfactory is evidenced by the close similarity of results obtained to those of other investigators (1947; 1948a; 1948b).

It is felt that this type of animal container is unique and that the uniqueness comes from the relatively long vertical dimension. Basically the mice have very little space to explore and soon settle down to basal conditions.

The container described could very easily be immersed in a constant temperature water bath for studies at other than room temperature.

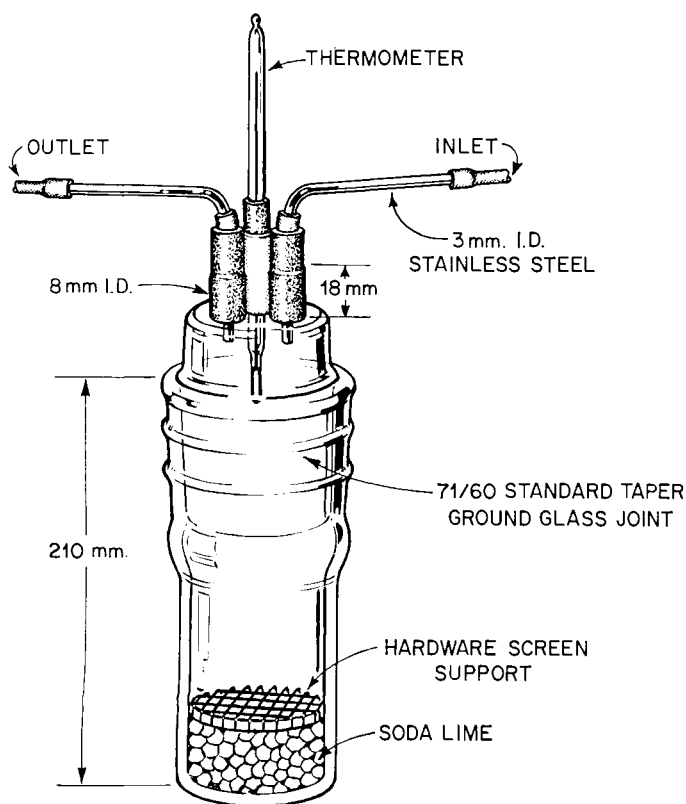

Figure 1. An apparatus for the measurement of oxygen consumption in mice.

LITERATURE CITED

¹ Biology Department, Coe College, Cedar Rapids, Iowa.

² Division of Biological and Medical Research, Argonne National Laboratory, Argonne, Illinois.

D'AMOUR, F. E., F. R. BLOOD and D. A. BELDEN, JR. 1965. Exp. 25—The effects of thyroidectomy and of thyroxin administration on the basal metabolic rate. *Manual for Laboratory Work in Mammalian Physiology*. University of Chicago Press.

MORRISON, P. R. 1948a. Oxygen consumption in several small wild animals. *J. Cell. Comp. Physiol.* 31:63-66.

———. 1948b. Oxygen consumption in several mammals under basal conditions. *J. Cell. Comp. Physiol.* 31:281-291.

PEARSON, O. P. 1947. The rate of metabolism of some small mammals. *Ecology* 28:127-145.