

## University of Wollongong Research Online

---

Faculty of Engineering and Information  
Sciences - Papers: Part B

Faculty of Engineering and Information  
Sciences

---

2019

### Characterization of a high spatiotemporal resolution monolithic silicon strip detector for MRI-linac dosimetry

Trent Causer

*University of Wollongong*, [tjc721@uowmail.edu.au](mailto:tjc721@uowmail.edu.au)

Tess Chapman

*University of Wollongong*, [tcc021@uowmail.edu.au](mailto:tcc021@uowmail.edu.au)

Bradley M. Oborn

*University of Wollongong*, [boborn@uow.edu.au](mailto:boborn@uow.edu.au)

Jeremy A. Davis

*University of Wollongong*, [jeremyd@uow.edu.au](mailto:jeremyd@uow.edu.au)

Marco Petasecca

*University of Wollongong*, [marcop@uow.edu.au](mailto:marcop@uow.edu.au)

*See next page for additional authors*

Follow this and additional works at: <https://ro.uow.edu.au/eispapers1>

 Part of the [Engineering Commons](#), and the [Science and Technology Studies Commons](#)

---

#### Recommended Citation

Causer, Trent; Chapman, Tess; Oborn, Bradley M.; Davis, Jeremy A.; Petasecca, Marco; Rosenfeld, Anatoly B.; and Metcalfe, Peter E., "Characterization of a high spatiotemporal resolution monolithic silicon strip detector for MRI-linac dosimetry" (2019). *Faculty of Engineering and Information Sciences - Papers: Part B*. 2828.

<https://ro.uow.edu.au/eispapers1/2828>

Research Online is the open access institutional repository for the University of Wollongong. For further information contact the UOW Library: [research-pubs@uow.edu.au](mailto:research-pubs@uow.edu.au)

---

## Characterization of a high spatiotemporal resolution monolithic silicon strip detector for MRI-linac dosimetry

### Abstract

Multiple vendors are now offering real-time MRI-guided radiotherapy systems. Quality assurance of small fields delivered with an MR-RT system requires detectors with high spatiotemporal resolution, and magnetic insensitivity. High spatial resolution is required to characterise the asymmetric penumbra that transverse designs demonstrate. In this work the authors describe the characterisation of the dosimetric performance of a monolithic silicon strip detector mounted to a flexible polyimide (Kapton) printed circuit board intended for use in MRI-linac dosimetry.

### Disciplines

Engineering | Science and Technology Studies

### Publication Details

Causser, T. J., Chapman, T., Oborn, B. M., Davis, J. A., Petasecca, M., Rosenfeld, A. B. & Metcalfe, P. (2019). Characterization of a high spatiotemporal resolution monolithic silicon strip detector for MRI-linac dosimetry. *Journal of Physics: Conference Series*, 1154 (Conference 1), 012006-1-012006-4.

### Authors

Trent Causser, Tess Chapman, Bradley M. Oborn, Jeremy A. Davis, Marco Petasecca, Anatoly B. Rosenfeld, and Peter E. Metcalfe

PAPER • OPEN ACCESS

## Characterization of a high spatiotemporal resolution monolithic silicon strip detector for MRI-linac dosimetry

To cite this article: T J Causer *et al* 2019 *J. Phys.: Conf. Ser.* **1154** 012006

View the [article online](#) for updates and enhancements.



**IOP | ebooks™**

Bringing you innovative digital publishing with leading voices to create your essential collection of books in STEM research.

Start exploring the collection - download the first chapter of every title for free.

# Characterization of a high spatiotemporal resolution monolithic silicon strip detector for MRI-linac dosimetry

T J Causer<sup>1,2</sup>, T Chapman<sup>1</sup>, B M Oborn<sup>1,2</sup>, J A Davis<sup>1</sup>, M Petasecca<sup>1</sup>,  
A B Rosenfeld<sup>1</sup> and P Metcalfe<sup>1</sup>

<sup>1</sup>Centre for Medical Radiation Physics, University of Wollongong, NSW, Australia

<sup>2</sup>Illawarra Cancer Care Centre, Wollongong, NSW, Australia

E-mail: tjc721@uowmail.edu.au

**Abstract.** Multiple vendors are now offering real-time MRI-guided radiotherapy systems. Quality assurance of small fields delivered with an MR-RT system requires detectors with high spatiotemporal resolution, and magnetic insensitivity. High spatial resolution is required to characterise the asymmetric penumbra that transverse designs demonstrate. In this work the authors describe the characterisation of the dosimetric performance of a monolithic silicon strip detector mounted to a flexible polyimide (Kapton) printed circuit board intended for use in MRI-linac dosimetry.

## 1. Introduction

There are now multiple vendors offering radiotherapy systems with online magnetic resonance (MR) image guidance. These systems can provide superior soft tissue contrast compared to kV photon image guidance technologies. The ViewRay MRIdian® Linac system combines 6MV flattening-filter free linac with a 0.35T MRI scanner. The Elekta Unity integrates a 7MV flattening-filter free linac system with a 1.5T MRI scanner [1-3]. In both systems the magnetic field axis is perpendicular to the beam axis. With this configuration the Lorentz force that acts on secondary electrons causes electron return effect (ERE) at high/low density interfaces and creates lateral asymmetry in beam penumbra [4].

To meet the needs of quality assurance of small fields delivered in the presence of a strong magnetic field detector systems with high spatial resolution, high temporal resolution and magnetic insensitivity are required. Monolithic silicon strip detectors have been shown to be suitable for small field dosimetry of linac beams [5]. The introduction of magnetic fields presents new challenges in detector design. In this work we characterise the dosimetric performance of a monolithic silicon strip detector mounted to a flexible polyimide printed circuit board (PCB) intended for use in MRI-linac dosimetry.

## 2. Materials and methods

The monolithic silicon strip detector, (sDMG-256A) consists of 256 phosphorous implanted (n<sup>+</sup>) strips of size 20x2000µm<sup>2</sup> with 200µm pitch on a bulk p-type silicon substrate. The silicon strip array is wire bonded to a flexible polyimide (Kapton) PCB carrier, shown in figure 1. The silicon and wire bonding are covered by a protective epoxy layer. The data acquisition (DAQ) system has been developed in house at the CMRP, it is based around the AFE0064 multichannel electrometer chip from Texas Instruments. To read out 256 channels, 2 analog-to-digital converters are used with 4

AFE0064's all synchronised by an FPGA. The data is passed from the FPGA to the user's computer via USB2.0 and accessed with a graphical user interface [6].

Dosimetric characterization of sDMG-256A included dose linearity investigated over the range (20-1000)cGy. Dose per pulse dependence (DPP) was measured over the range  $(0.29-4.66) \times 10^{-4}$  Gy/pulse. The set up was a  $10 \times 10 \text{ cm}^2$  field with the detector placed a 5cm depth in solid water, 10cm backscatter and the SSD varied from (70-300) cm. At each measurement point a CC13 ionisation chamber reference measurement was taken and corrected for recombination using two voltage method.

The angular dependence was investigated using the Dosepoint RT-smartIMRT® phantom. The detector was setup in the phantom such that the central detector channel was coincident with the central axis of rotation of the Dosepoint phantom. The linac gantry was stationary and the Dosepoint phantom was rotated, measurements taken every  $15^\circ$ .

Uniformity of detector channel response was accessed using a 6MV,  $20 \times 20 \text{ cm}^2$  field, with the detector at depth 10cm in a solid water phantom positioned at 100cm SSD. The uniformity is calculated as the differential response of each channel relative to the central channel. Measurements were performed on a Clinac 2100EX, Varian Medical Systems using 6MV and 10MV beams.

The effect of air gap width in detector packaging for small field output factor (OF) measurements in the presence of 1.2T transverse magnetic field was investigated. The magnetic field is generated using a portable permanent magnet system shown in figure 1. A bespoke phantom was required to position the detector array in the gap between the cones of the permanent magnet and to allow precise changes to the airgap above the diodes. Measurements are performed at an extended SSD as the magnetic apparatus does not physically fit closer to the linac source, this extended distance also allows the fringe field of the magnet to drop below expected background levels at the linac head as not to affect the linac operation. Measurements were taken at 150cm SAD for field sizes 3, 5, 10,  $15 \text{ mm}^2$  and air gaps 0, 0.36, 0.72, 1.08mm. A replica of the magnet system that does not contain the neodymium-iron-boron magnets was used to perform zero field measurements with the same scatter conditions, in order to isolate magnetic field effects on the detectors response.

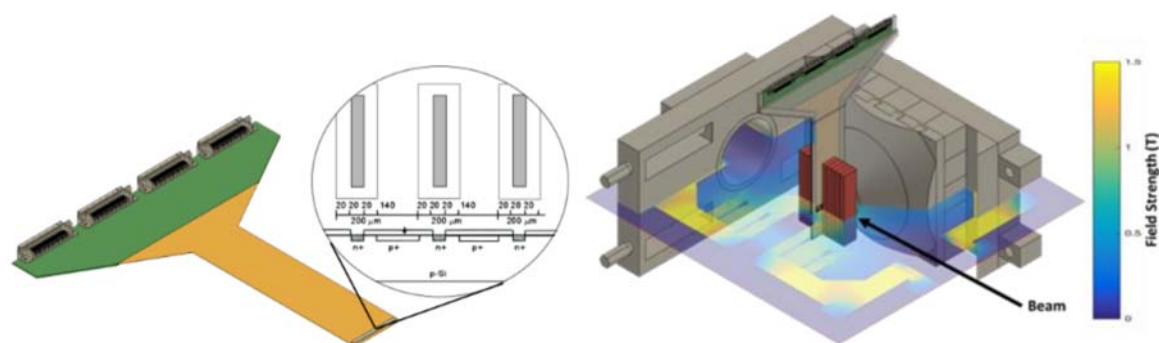

**Figure 1.** Left - sDMG-256A, green is FR4 section of PCB, orange is the flexible polyimide. Right Output factor measurement setup with portable permanent magnet system.

### 3. Results

The dose response of sDMG-256A for (20-1000) cGy shown in figure 2 displays a linear response ( $R^2 = 1$ ). The dose per pulse dependence shown in figure 2 displays a 10.3% variation over the range  $(0.29-4.65) \times 10^{-4}$  Gy/pulse. The uniformity of the sDMG-256A in figure 3 shows before applying the equalization vector detectors channel response relative to the central channel for 99% of channels were within  $\pm 5\%$ . After channel normalisation the variation of all channels was within 0.2%. The angular response of the sDMG-256A's central channel is displayed in figure 3. A 20% decrease in response was observed for beam angles parallel to the long axis of the detectors monolithic silicon chip. The effect of an air gap above the detectors sensitive volume is known to decrease the OF of diodes and has been used to correct for the diodes overresponse to small fields [7]. Comparing the OF for a range

of air gaps and field sizes it is observed as shown in figure 4 that an increase in airgap width results in a decreased in measured OF in a transverse magnetic field with the effect being larger for smaller field sizes compared to the B=0 case. This implies that the method of compensating the overresponse of diodes to small field OF's cannot be translated into an MRI-linac environment. This decreased response in the presence of a transverse magnetic field is due to ERE of secondary electrons within the air gap above the silicon diodes.

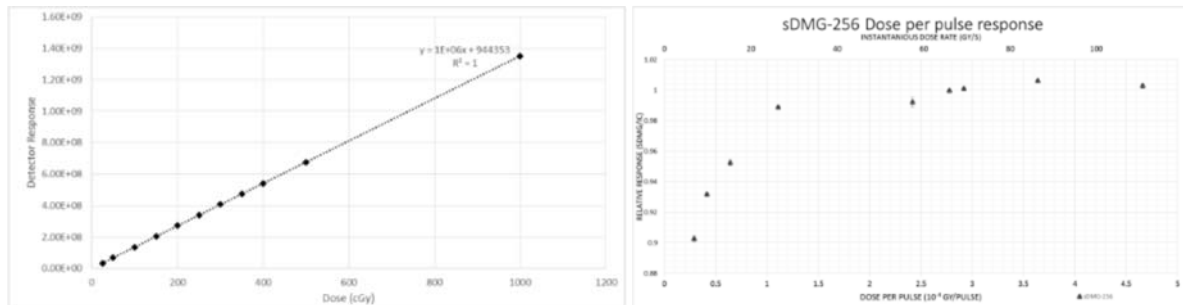

Figure 2. Left – dose linearity, Right – sDMG-Dose per pulse response normalized to  $2.78 \times 10^{-4}$  Gy/pulse.

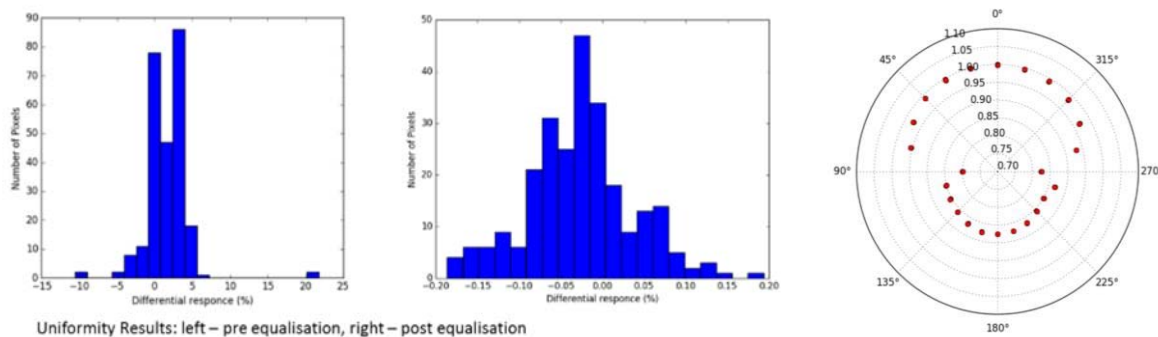

Figure 3. Left - histogram of uniformity results pre-equalisation, Centre - histogram of uniformity results post equalisation, Right - Angular response of central channel.

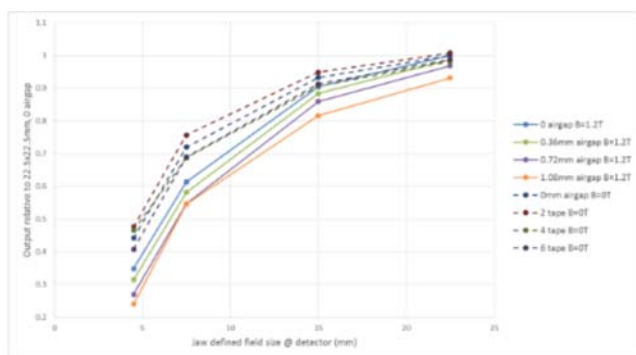

Figure 4. Effect of air gap above detector on small field output factor measurement (solid lines – B=1.2T, dashed lines – B=0T).

#### 4. Conclusion

The preliminary dosimetric characterisation of a monolithic silicon strip detector mounted to flexible polyimide carrier has been carried out. The sDMG-256A has been tested at 1.2T with small fields. Preliminary results describe a complex change in output factor that depend on B-field and air-gap. We are working on an insert that will ameliorate the effect of the air gap above the dosimeter. Further

work will be required to describe a complete characterisation of the response of the system for various magnetic fields and x-ray beam field sizes.

## 5. References

- [1] Gargett M *et al* 2015 *Med. Phys.* **42** 856-65
- [2] Mutic S *et al* 2014 *Semin. Radiat. Oncol.* **24** 196-9
- [3] Raaymakers B W *et al* 2017 *Phys. Med. Biol.* **62** L41
- [4] Raaymakers B W *et al* 2004 *Phys. Med. Biol.* **49** 4109-18
- [5] Aldosari A H *et al* 2014 *Med. Phys.* **41** 91707
- [6] Fuduli I *et al* 2014 *J. Instrum.* **9** T06003
- [7] Al Shukaili K *et al* 2017 *Med. Phys.* **44** 628-36