

CLEARING OF TRANSIENT FAULTS IN MV NETWORKS

C.J. VAN DER MESCHT¹ & W.J.D VAN SCHALKWYK²
ENGINEER¹ & CHIEF ENGINEER², ESKOM DISTRIBUTION

Abstract

This paper contains research performed on the effectiveness of methods that aims to clear transient faults on MV networks without causing momentary supply loss to customers due to ARC operations, which is achieved by “instantaneous” interruption of fault currents. This is done by momentarily disconnecting the NECR’s neutral earth connection. Currently the research also includes the implementation of single pole breakers which are able to trip independently from each other within 25ms. Implementing these methods of clearing transient faults will result in less stress being placed on breakers, joints, conductors and transformers within the MV network. It will also yield a better QoS performance with regards to dips and momentary interruptions. Lastly, the scheme will result in up to 50 times less burn wounds on people or animals in the unfortunate case of making contact with the MV network.

Keywords: Transient fault, Medium voltage, Capacitive coupling

1. INTRODUCTION

Currently the majority of breaker operation within MV networks can be ascribed to temporary faults which are caused for example by lightning. With regards to phase to phase faults it is quite difficult to quench a temporary fault without a breaker operation due to the fact that the fault currents are much higher as when compared to earth faults. Secondly, with phase to phase faults there is no way to clear the fault current path without interrupting supply to customers. In the case of earth faults, if the fault current path is removed, the fault will quench provided that the capacitive coupling of the MV network is such that the capacitive current is limited below 35A (Hanninen, 2001).

Due to the amount of pole mounted breakers currently installed on MV feeder protection settings proves to be challenging which results in breakers closer to the end of the feeders having to take longer to trip for faults to ensure for proper network protection grading. This results in faults remaining on networks for extended periods.

In order to attempt to quench transient earth faults on MV networks a system was implemented at 9 substations across the Free State and monitored for a period of one year by means of installing ELSPEC continuous loggers which record with a sampling rate of 400kHz at each site. Each installation was also physically tested in order to ensure for the proper operation and functioning.

Planning and design is currently being conducted in order to attempt to clear temporary phase to phase faults without causing a momentary interruption of supply to customers as compared to a normal breaker ARC operation.

2. LITERATURE REVIEW

All types of faults in an electrical network do put strain on electrical equipment to a certain degree. Equipment that is typically the most exposed to repeated faults in an electrical network are:

- Breakers
- Joints and jumpers
- Conductors
- Transformers
- Links

During temporary and permanent faults the quality of supply of an electrical network is also affected in terms of dip performance and momentary and permanent interruptions (Zhang & Bollen, 2000).

2.1 Electrical arc

Electrical arcs can be quenched in a number of different ways. The most common way of quenching an arc is to remove the source of current feeding into the fault by breaker operations. Inside the breaker the arc is quenched by an insulation medium (oil, vacuum or SF6) as the breaker contacts part from each other (Cohen, 2002). An arc on an overhead line can also quench as the hot ionised air caused by the electrical arc rises taking the arc with it to a point where the arc impedance increases such that the arc quenches as illustrated in Figure 1. This same theory can be applied if there are strong winds present and the electrical arc is blown away which also increases the electrical arc resistance such that the fault is quenched. Another mechanism that assists in quenching an electrical arc is if the magnetic forces which are caused by the fault current can be used to “blow” the arc away. Studies conducted in Finland regarding unearthed 20kV networks (Hanninen, 2001), have concluded that if the capacitive fault current in an overhead electrical network can be reduced to a point below 35A the electrical arc should quench.



Fig 1: Arc quenching

Unfortunately in the case of a phase to phase fault it is quite difficult to limit the high fault currents to a point below 35A. In the case of a single phase to earth fault this will be possible by temporarily unearthing the MV network under such conditions in order to remove the return path of the fault current back to the substation NEC. The single phase to earth fault should quench provided that the fault is of a temporary nature and capacitive coupling of the unearthed MV network is less than 35A.

2.2 NEC neutral breaker

The NEC breaker works on the principal that it unearths the MV network for a period of 2 seconds in order to give the transient earth fault enough time to clear. After unearthing the MV network for a period of 2 seconds the NEC breaker will return to the normally closed position and remain in lockout for a period of 60 seconds in order to give the normal breaker protection a chance to clear the network fault. According to the data obtained during the 1 year testing period it was found that most of the transient earth fault typically clears within the first 200ms after the NEC breaker trips. A schematic drawing of the NEC breaker is given in Figure 2 and the practical layout is shown in Figure 3.

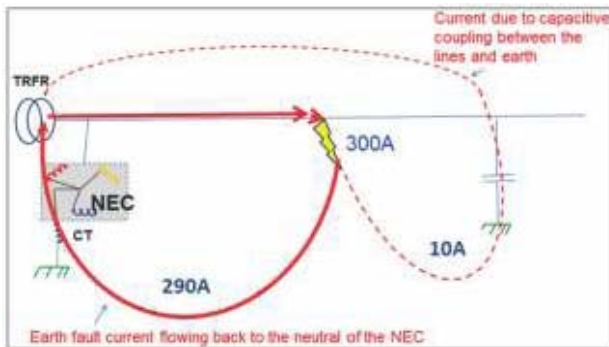

Fig 2: Overview of NEC breaker setup



Fig 3: Practical installation of a NEC neutral breaker

2.3 System voltages in an unearthed network under earth fault conditions

In the case of a solidly earth system under fault conditions (e.g. $V_a =$ earth potential) the healthy phases to earth voltages will not drastically increase due to the network voltage neutral reference point remaining fixed. However as soon as the system is unearthed under fault conditions the network voltage neutral reference point will shift which will result in full phase to phase system voltages being present across phase to earth terminals as illustrated by Scholtz in Figure 4.

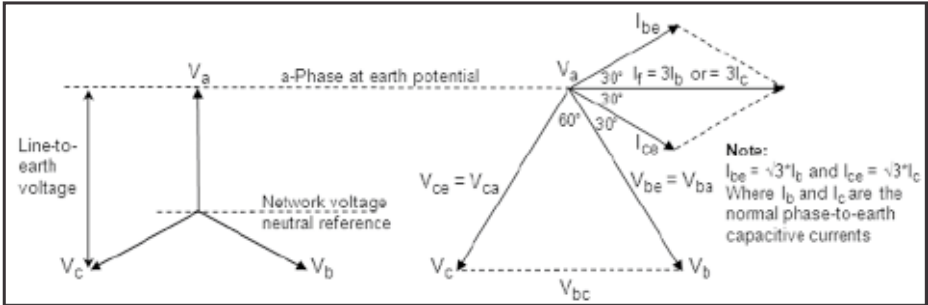

Fig 4: Capacitive current and system voltage vectors of an unearthed MV network during an earth fault condition

Due to the increase in system voltages on the two healthy phases the MV neutrals of all substation transformers are required to be fully insulated (partially graded) as mentioned by Heathcote. In the case of Eskom transformers this is usually the case as the MV windings of substation transformers are in delta configuration and use is made of neutral earthing compensators which have a neutral resistor (NECR). Therefore it is important that the NECR is fully insulated.

2.4 Capacitive coupling of MV networks

The total capacitive coupling of a MV overhead line to earth under normal operating conditions is not much due to the presence of all three phases which cancel each other out (Mariani, 2007). However, under a single phase to earth fault condition in an unearthed network the picture changes quite drastically especially in the case of long rural lines feeding from the same substation as illustrated by Scholtz in Figure 5. One should note that I_b and I_c are the nominal phase-to-earth capacitive currents.

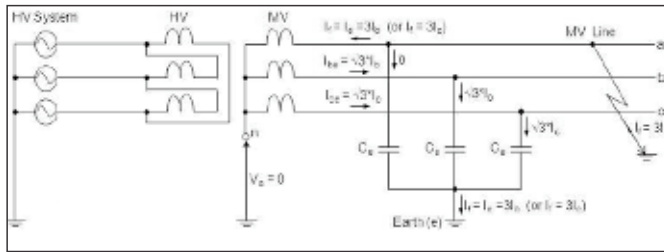

Fig 5: Flow of capacitive currents during an earth fault with regards to an ungrounded network

From Figure 5 the capacitive current can be expressed as being:

$$I_{\text{Capacitive total}} = (I_{be} + I_{ce})\cos 30^\circ$$

Theoretically the capacitive current can be written as (assuming delta overhead line configuration):

$$I_{\text{Capacitive total}} = 2\sqrt{3}\pi f V_{\text{phase-phase}} C_{\text{conductor}}$$

For a 22kV overhead line with a length of approximately 170km under a 300A transient earth fault condition the typical fault currents are shown in Figure 6.

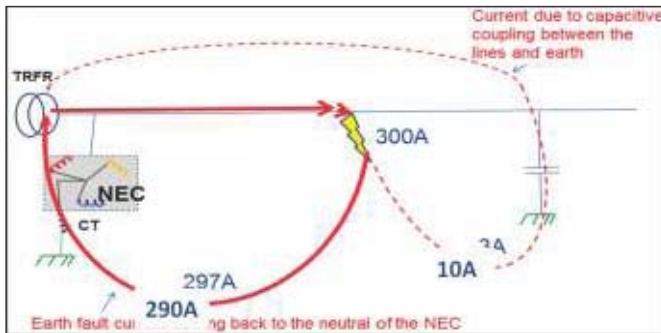

Fig 6: A concept for simple understanding that shows the current paths for a 300A transient earth fault condition with NEC breaker in closed position. The current path in the dotted line shows what the current flow of the capacitive coupling that will increase to 10A when the NEC breaker opens

After the NEC breaker opens in order to quench the transient earth fault there will only be approximately 10A of capacitive current flowing as indicated is in Figure 7 and Figure 8.

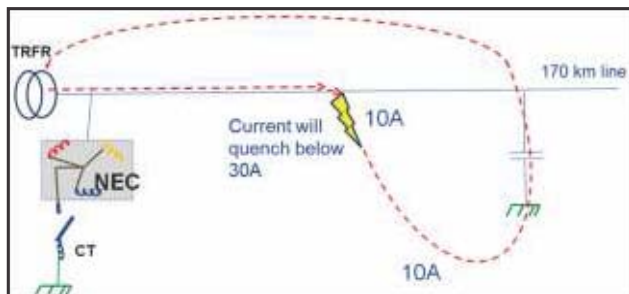

Fig 7: A concept showing the NEC breaker in the open position

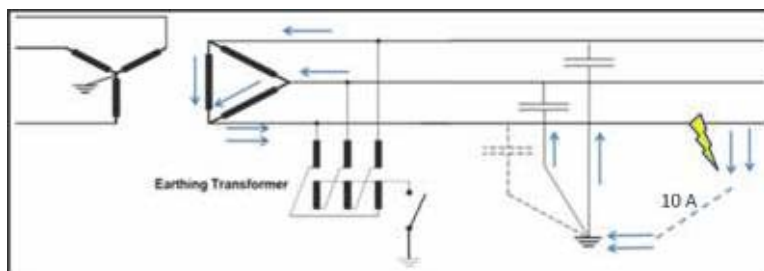

Fig 8: Current flow with neutral breaker in the open position

The combined length of the MV overhead line from the substation where the NEC breaker is installed has a direct effect on the effectiveness of the NEC breaker scheme. Tests were performed on 22kV lines that vary from 17km to 570km in length. Theoretically 22kV lines with lengths of 17km and 570km could yield capacitive currents of up to 1.8A and 60A respectively. If the earth resistance were to be taken into account the capacitive current which could be expected from 17km and 570km lines roughly equates to 1A and 35A which is supported by measurements which were taken.

3. Research Methodology

3.1 Measurements

Elspec loggers were installed at each site where the NEC breaker scheme was installed. Metering CT's or transformer protection CT's were used in order to measure the current. Transformer VT's were used in order to measure the voltage as shown in Figure 9. All measurements were compared with breaker operation data on SCADA.

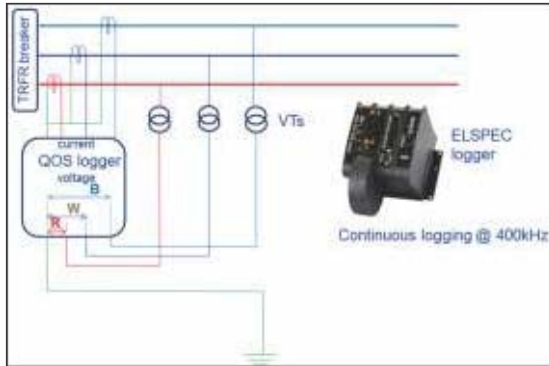

Fig 9: Measurement method

3.1 Simulations

A model was created in ATP draw and simulations were performed prior to field testing to determine to what extent the voltage of the two healthy phases will rise under a transient earth fault condition in an unearthed network. The simulation model and results are shown in Figure 10 and Figure 11 respectively. Note that on the LV network (secondary side of the Δ -Y transformer) the customer does not experience any high voltages.

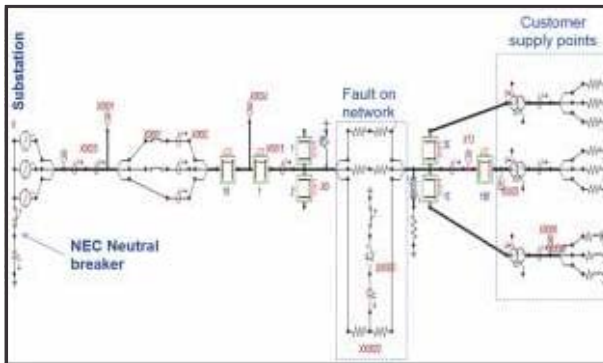

Fig 10: ATP draw model of NEC breaker

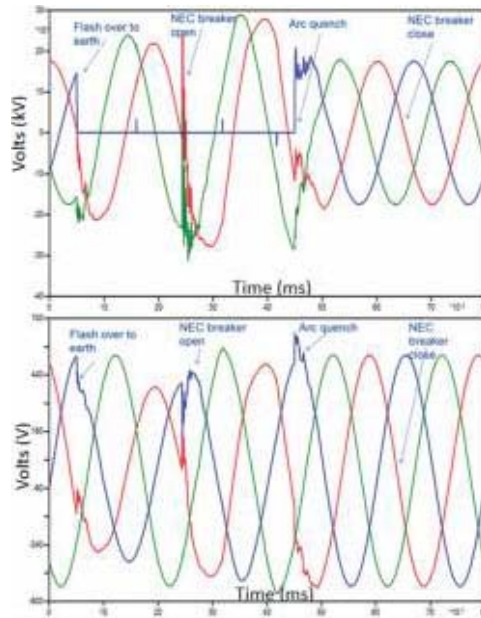

Fig 11: MV and LV network voltage simulated results

3.3 Physical onsite testing

In order to verify the simulated results and as part of the NEC breaker commissioning procedure physical tests were performed at each point of installation. These tests included:

- Clearing of low impedance transient earth fault shown in Figure 12
- Clearing of high impedance transient earth fault
- Permanent earth fault shown in Figure 13

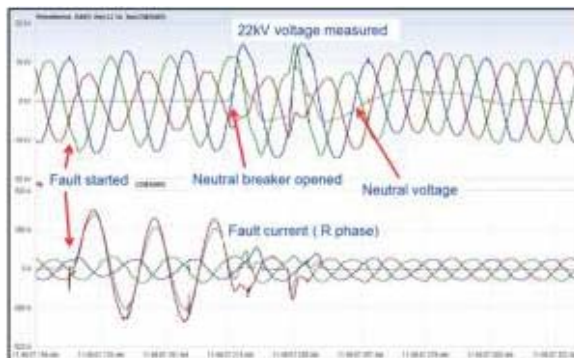

Fig 12: Measure transient earth fault cleared by NEC breaker scheme when conducting on site tests

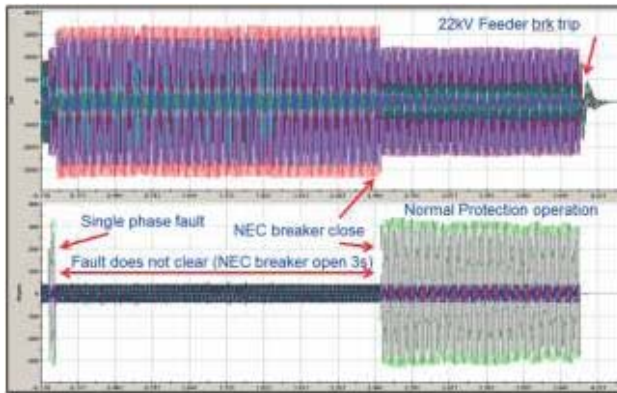

Fig 13: Measured permanent earth fault not cleared by NEC breaker scheme when conducting on site tests

4. FINDINGS AND DISCUSSION

A summary of the sites where the NEC breakers were installed in the Free State is given in Table 1. Locations were chosen where the capacitive current was well below the 35A mark when unearthing the MV network. With the exception of Vrede Munic all MV networks consisted only of overhead conductors. The majority of the Vrede Munic network consists of the municipal underground cable network.

Table 1: Locations where NEC breakers have been installed

Substation	Line lengths (m)	System voltage (kV)	# feeders	Customer count
Thabong Bulk	36,430	11	9	6524
Thabong East	200,647	11	8	14382
Theunissen Munic	282,484	11	9	5668
Kutlwanoong	50,475	11	8	11934
Wesselsbron Munic	24,889	11	3	5420
Bohlokong	38,804	11	7	10845
Meloding	148,593	11	5	10730
Vrede Munic	26,780	11	2	4359

The performance of the NEC breaker at all substations are in the figures below. One should note that the NEC breaker that was installed at Vrede Munic did not prove to yield any significant positive results due to the fact that earth faults in cable networks are less and typically permanent in nature.

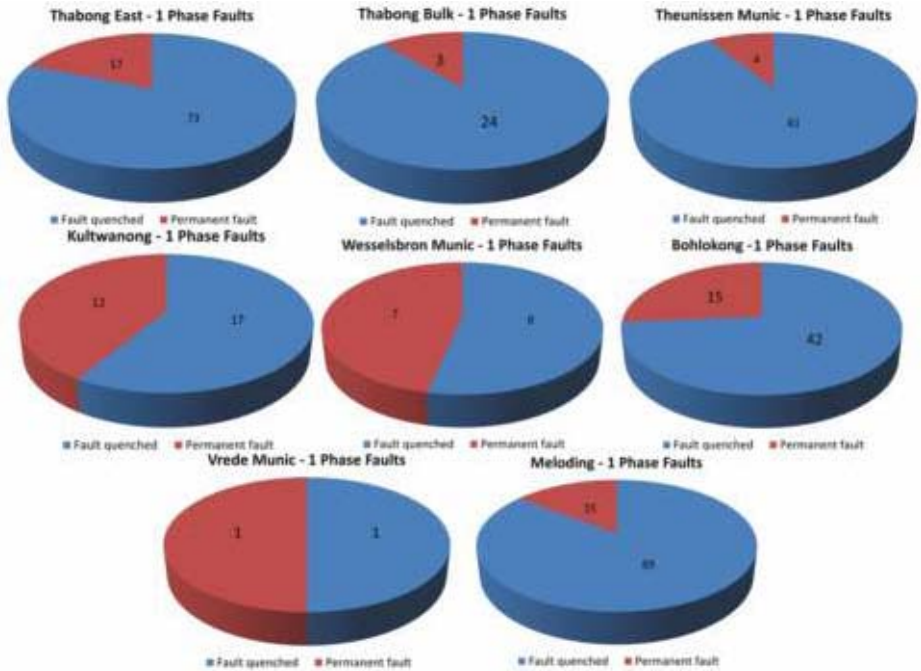

Fig 14: Summary of single phase to earth fault events

The primary goal of the NEC breaker is to clear transient earth faults, but it does pose the added advantage that the scheme might assist with the clearing of phase to phase fault although the probability of clearing a phase to phase fault is quite low. During the course of the one year trial period NEC breaker operations for phase to phase to earth faults were also analysed and the results are shown below. Clearing of these faults is a “bonus” and the NEC breaker contributes very little as it only quenches the fault current to earth. Due to the reduction in ionized air, it may contribute to an arc quench.



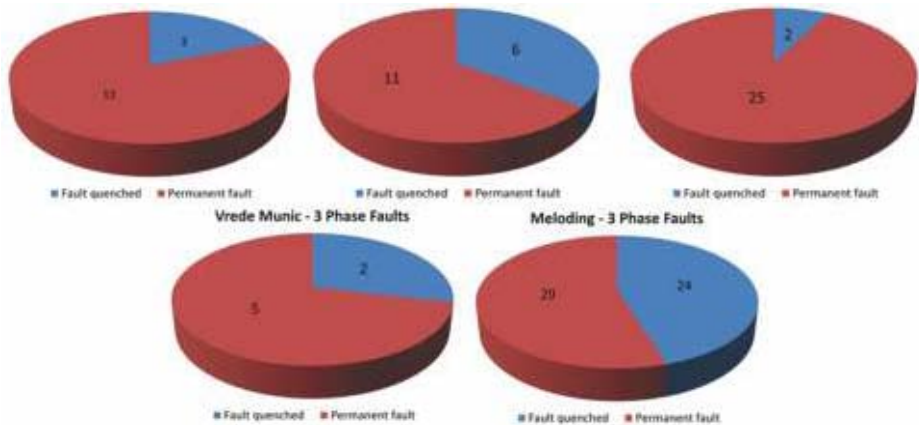

Fig 15: Summary of phase to phase fault events

During the course of the one year testing period it has been found that the amount of capacitive current is linearly dependent on the combined length of the feeders on the same busbar. When comparing 11kV and 22kV networks with each other the line lengths of the 11kV network can be up to twice as much as when compared to a 22kV network for the same capacitive current flow. Measurements of tests performed on two other NEC breaker installations with regards to capacitive coupling current is shown in Figure 16 and Figure 17.

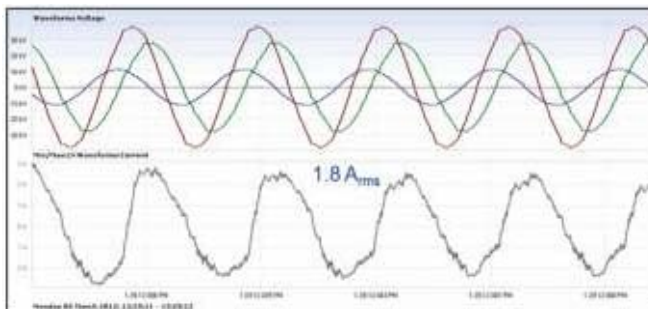

Fig 16: Capacitive current on 22kV, 17km overhead line

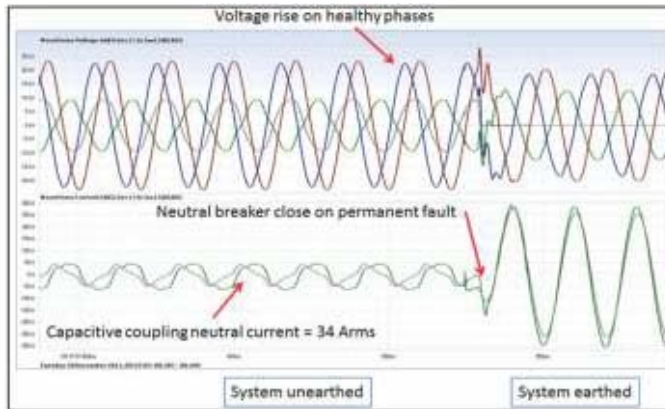

Fig 17: Capacitive current on 22kV, 570km overhead line

During the unearthing of the electrical systems under fault conditions the highest phase to earth voltage measured with regards to phase-to-phase and phase-to-earth faults during the one period did not exceed twice the rated voltage. Studies performed by Allan & Waldorf [1946,301] also supported these findings.

5. CONCLUSION AND FURTHER RESEARCH

The NEC breaker scheme proved to be effective in clearing transient earth faults. Although some success has been recorded in the case of phase to phase to earth faults it is not the primary function of the scheme. In the case of Vrede substation the scheme did not prove to be that effective due to the cable networks that are used in that network. At all other substations where only overhead conductors are used the scheme yielded positive results. The NEC breaker scheme currently in operation at Vrede munic substation will be moved to a more appropriate location in the near future.

With regards to capacitive coupling, in the case of 11kV and 22kV overhead lines the total combined line length should not exceed 400km and 200km respectively in order to ensure successful quenching of transient earth faults when temporary unearthing the network.

Further research has been conducted in order to clear temporary phase to phase faults without causing a momentary interruption to customers. The proposed idea is to install three separate single pole breakers on an overhead line. The proposed breaker will have the capability that it will be able to trip within 20ms from detecting a fault condition.

Single phase tripping with different protection settings on each phase breaker will be implemented. For a phase to phase fault, only the one phase will trip and the arc between the phases will quench.

For a single phase to earth, only the faulty phase will trip. A three phase fault will result in 2 breakers tripping and will result in a temporary outage to the customer. The single pole breaker will therefore be installed at the beginning of a MV overhead line and will be set to trip instantaneously to save other breakers from operating on the same feeder. The primary intention is to make the fault current duration as short as possible and to minimize damage to equipment. This will generate less ionized air and enhance arc quenching. Secondly, customer interruptions will be less and in some cases only one phase will be lost temporary. Lastly the intention is to achieve less breaker operations. Simulations have been conducted by using ATPdraw and the network model is shown in Figure 18.

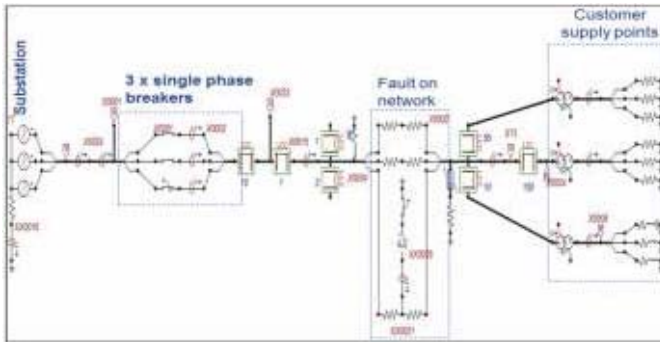

Fig 18: ATP draw model of single pole breakers

A phase to phase fault scenario was simulated and the results are shown in Figure 19.

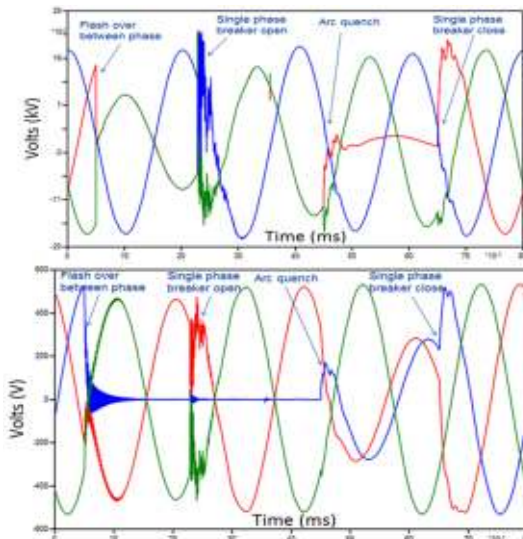

Fig 19: MV and LV network voltage simulated results for a phase to phase fault

A phase to earth fault scenario was also simulated and the results are shown in Figure 20.

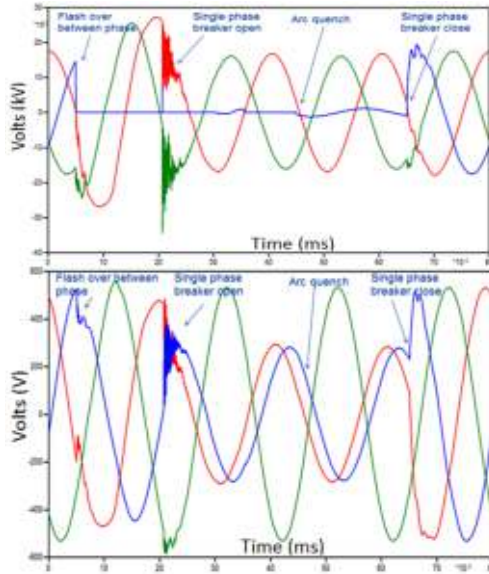

Fig 20: MV and LV network voltage simulated results for a phase to earth fault

In summary the two schemes have been compared with each other in Table 2.

Table 2: Comparison between NEC breaker scheme and proposed single pole breaker scheme

	NEC Neutral Breaker	Proposed single pole breaker
Cost per substation	R200 000	R100 000
Coverage	All MV feeders connected to respective Trfr NEC(s)	MV line only
Mounting location	Inside substation yard	on MV line
Installation period	1-2 days	4 hours
Breaker size and weight	70kg breaker on structure in substation	6kg breaker per phase on MV line
Line length	Max of 200km (combined) for 22kV lines and 400km for 11kV lines	Max of 200km per overhead feeder for 22kV lines and 400km per overhead feeder for 11kV lines
Fault quenching capabilities	single phase faults	single and phase-to-phase faults
Proposed sites	Substations with several short lines with many customers are connected.	Long MV line with many pole mounted breakers located in high lightning density areas, with many jumper and conductor failures
Effect on Customer	no effect	Single phase voltage drop for 1 second

6. ACKNOWLEDGEMENTS

Special thanks to Jan Scholtz, Mandri van der Mescht and Donald Schoeman.

7. REFERENCES

Allen, J.E., and Waldorf, S.K., 1946, "Arcing Ground Tests on a Normally Ungrounded 13kV 3-Phase Bus", IEEE Transactions Volume 65, May.

Cohen, V., 2002, "Application guide for the protection of L.V. Distribution systems, Circuit breaker industries Ltd.

Hänninen, Seppo, 2001, "Single phase earth faults in high impedance grounded networks", VTT Publications 453.

Heathcote, M.J, 1998, "The J & P Transformer Book", Woburn, Reed Educational and Professional Publishing Ltd.

Mariani, F., Bisnath, S., and Reynders, J., 2007, "Inductive instrument transformers and protective applications", Johannesburg, Crown Publications.

Scholtz, J.P, 2011, "Improved transient earth fault clearing on solid and resistance earthed MV networks".

Zhang, L., and Bollen, H.J., 2000, "Characteristics of Voltage Dips (Sags) in Power Systems", IEEE Transactions on Power Delivery Volume 15, April.