

**DESIGNING FOR RAPID MANUFACTURE**  
**GUILLAUME GERBER**

Dissertation submitted for the fulfilment of the requirements of  
the degree

**MAGISTER TECHNOLOGIAE:**  
**ENGINEERING: MECHANICAL**

in the

School of Mechanical Engineering and Applied Mathematics  
Faculty of Engineering, Information and Communication  
Technology

at the

Central University of Technology, Free State

Supervisors

Mr. L Barnard (M.Tech: Engineering)  
Prof. DJ de Beer (D. Tech: Engineering)

July 2008

## DECLARATION OF INDEPENDENT WORK

I, Guillaume Francois Gerber, hereby declare that this research project submitted for the degree MAGISTER TECHNOLOGIAE: ENGINEERING: MECHANICAL, is my own independent work that has not been submitted before to any institution by anyone else or myself as part of any qualification.

SIGNATURE OF STUDENT

DATE

## ACKNOWLEDGEMENTS

I sincerely thank my study-leaders, mr. Ludrick Barnard and professor Deon de Beer for the guidance and positive critique that I received from them. Without their input this research project would indeed have been a far more daunting task.

## ABSTRACT

As the tendency to use solid freeform fabrication (SFF) technology for the manufacture of end use parts grew, so too did the need for a set of general guidelines that would aid designers with designs aimed specifically for rapid manufacture. Unfortunately, the revolutionary additive nature of SFF technology left certain fundamental principles of conventional design for manufacture and assembly outdated. This implied that whole chapters of theoretical work that had previously been done in this field had to be revised before it could be applied to rapid manufacturing. Furthermore, this additive nature of SFF technology seeded a series of new possibilities and new advantages that could be exploited in the manufacturing domain, and as a result drove design for rapid manufacturing principles even further apart from conventional design for manufacture and assembly philosophy.

In this study the impact that rapid manufacture had on the conventional product development process and conventional design for manufacture and assembly guidelines were investigated. This investigation brought to light the inherent strengths and weaknesses of SFF, as well as the design for manufacture and assembly guidelines that became invalid, and consequently lead directly to the characterization of a set of design for rapid manufacture guidelines.

**Keywords:** rapid manufacture, design for rapid manufacture, solid freeform fabrication, laser sintering, design for laser sintering, DFRM, DFSL, RM.

## OPSOMMING

Soos wat die tendens om solide vryvorm vervaardiging te gebruik vir die vervaardiging van gebruikersprodukte toegeneem het, het daar 'n behoefte aan 'n stel algemene riglyne wat ontwerpers kan lei wanneer hulle produkte spesifiek vir snelvervaardiging ontwerp ontwikkel.

Ongelukkig het die revolusionêre natuur van solide vryvorm vervaardiging tegnologie sekere fundamentele eienskappe van konvensionele vervaardiging as verouderd agtergelaat. Dit het by implikasie beteken dat hoofstukke teoretiese werk wat voorheen op die gebied van ontwerp vir vervaardiging gedoen is, eers opgedateer sou moes word alvorens dit in hierdie nuwe vervaardigingsomgewing toegepas kon word.

Verder het solide vryvorm vervaardiging ook 'n hele reeks nuwe moontlike en voordele wat benut sou kon word gebied, en gevolglik is die wig wat tussen konvensionele vervaardigingsprosesses en SFF prosesse lê nog dieper ingedryf.

Tydens hierdie studie het die impak wat solide vryvorm vervaardiging tegnologie en snelvervaardiging op die konvensionele produk ontwikkelingsproses en konvensionele ontwerp vir vervaardiging ondersoek. Hierdie studie het dan ook die onderliggende sterk-en swakpunte van solide vryvorm vervaardiging bloot gestel, terwyl dit terseldetyd ook aangedui het watter konvensionele ontwerp vir vervaardigingsriglyne toepaslik in die nuwe vervaardigingsparadigma sou bly/ Gevolglik het dit direk gelei tot die karakterisering van 'n stel riglyne gelei, wat ontwerpers sou kon rig om snelvervaardiging optimaal te benut.

**Sleutelwoorde:** Snelvervaardiging, ontwerp vir snelvervaardiging, soliede vryvormvervaardiging, laser sintering, ontwerp vir laser sintering.

## TABLE OF CONTENTS

Declaration of independent work .....	i
Acknowledgements .....	ii
Abstract .....	iii
Opsomming .....	iv
List of figures .....	xiv
List of tables .....	xvii
List of equations .....	xviii
Symbols, abbreviations & acronyms .....	xix
Abbreviations and acronyms .....	xix
Symbols .....	xix
Greek symbols .....	xix
1.    Introduction .....	1
1.1. Chapter Objectives .....	1
1.2. Introduction to solid freeform fabrication and rapid manufacturing .....	1
1.3. Problem Statement .....	3
1.4. Hypothesis .....	4
1.5. Objective .....	4
1.6. Chapter Summary .....	5
2.    Preamble .....	7
2.1. Chapter Objectives .....	7
2.2. Defining conventional manufacture .....	7
2.3. An introduction to solid freeform fabrication .....	12
2.4. The product development process .....	14
2.4.1. Introduction .....	14
2.4.2. The product development process .....	15
2.5. Chapter Summary .....	30
3.    Rapid manufacture: Possibilities and restrictions .....	32
3.1. Chapter objectives .....	32

3.2.	New possibilities initiated by solid freeform fabrication and rapid manufacturing .....	32
3.2.1.	Design freedom.....	32
3.2.2.	Design optimisation .....	34
3.2.3.	Part consolidation .....	35
3.2.4.	Customisation.....	35
3.2.5.	New manufacturing paradigms.....	36
3.2.6.	Digital distributive production .....	37
3.2.7.	Multiple savings .....	37
3.3.	Restrictions imposed by RM technology.....	38
3.3.1.	Accuracy, detail, surface finish and build times .....	38
3.3.2.	Material constraints .....	40
3.4.	RM material properties .....	41
3.4.1.	Isotropic behaviour of RM material .....	41
3.4.2.	The effect of notch manufacturing on the impact strength of RM material .....	42
3.5.	Comparison of RM and conventional manufacturing processes ..	43
3.6.	Chapter summary .....	46
4.	Selection of representative processes for conventional and rapid manufacture .....	48
4.1.	Chapter objectives .....	48
4.2.	Selecting a representative process for SFF .....	49
4.2.1.	Material: Mechanical properties and availability.....	49
4.2.2.	Support structures and multi-layer production .....	50
4.2.3.	Reuse of material .....	50
4.2.4.	Production process .....	51
4.2.5.	Modelling ability .....	52
4.2.6.	Isotropic behaviour .....	53
4.3.	Conclusion .....	54
4.4.	Selection of a process to represent conventional manufacture....	56
4.5.	Chapter summary .....	56



5.	Description of the representative conventional manufacturing process .....	58
5.1.	Chapter objectives .....	58
5.2.	Plastic injection moulding .....	58
5.3.	The process of plastic injection moulding.....	59
5.4.	Moulds.....	62
5.5.	Chapter summary .....	64
6.	The product development process for injection moulded parts .	65
6.1.	Chapter objectives .....	65
6.2.	The product development process for injection moulding.....	65
6.2.1.	Ideation .....	66
6.2.2.	Refinement.....	67
6.2.3.	Implementation.....	68
6.3.	Chapter summary .....	69
7.	Design for injection moulding .....	70
7.1.	Chapter objectives .....	70
7.2.	Design for manufacture guidelines for injection moulding .....	70
7.2.1.	Wall thickness constraints .....	71
7.2.2.	Sink marks .....	73
7.2.3.	Sharp Corners.....	73
7.2.4.	Mould filling: Gate and melt flow .....	74
7.2.5.	Weld and meld lines.....	77
7.2.6.	Parting line consideration.....	78
7.2.7.	Ejection pin marks and gate marks.....	79
7.2.8.	Taper or draft angle .....	79
7.2.9.	Geometric structural reinforcement.....	80
7.2.10.	Undercuts.....	82
7.2.11.	Coring .....	83
7.2.12.	Blind holes.....	84
7.2.13.	Holes.....	85
7.2.14.	Self-tapping screws.....	86

7.2.15.	Plastic threads .....	86
7.2.16.	Press fits .....	88
7.2.17.	Bosses .....	88
7.2.18.	Snap-fits .....	90
7.2.19.	Internal hinges.....	93
7.3.	Summary of injection moulding DFM guidelines.....	95
7.4.	Chapter summary .....	102
8.	Description of the representative SFF manufacturing process	104
8.1.	Chapter objectives .....	104
8.2.	Laser sintering.....	104
8.3.	Process description of laser sintering.....	105
8.4.	Chapter summary .....	109
9.	The rapid product development process .....	110
9.1.	Chapter objective.....	110
9.2.	The impact of rapid manufacture on the conventional product development process.....	110
9.2.1.	Ideation .....	111
9.2.2.	Refinement.....	113
9.2.3.	Implementation.....	117
9.3.	The rapid product development process.....	119
9.4.	Chapter summary .....	121
10.	Delineation of design for rapid manufacture guidelines.....	122
10.1.	Chapter objective.....	122
10.2.	Regarding the approach toward design and conceptualization..	122
10.3.	Relevancy of conventional design guidelines.....	123
10.4.	Exploiting the abilities of RM and downplaying incapacities ..	124
10.5.	Chapter summary .....	124
11.	Designing for rapid manufacture .....	126
11.1.	Chapter objective.....	126
11.2.	Introductory .....	126
11.3.	High order DFM guidelines.....	126

11.4.	General DFRM guidelines .....	127
11.5.	Designing for laser sintering .....	130
11.6.	Chapter summary .....	136
12.	Literary Case studies .....	137
12.1.	Chapter Objective .....	137
12.2.	Bafbox case study .....	137
12.2.1.	Introductory .....	137
12.2.2.	Limitations of the product .....	138
12.2.3.	Design criteria .....	139
12.2.4.	Concept creation and manufacture of parts .....	139
12.2.5.	Comparison of designs .....	140
12.2.6.	Discussion.....	141
12.2.7.	Conclusions.....	143
12.3.	Front plate of a diesel fuel injection system .....	144
12.3.1.	Introductory .....	144
12.3.2.	Redesigning for rapid manufacture .....	145
12.3.3.	Conclusion .....	149
12.4.	Chapter Summary.....	149
13.	Experiments .....	151
13.1.	Chapter objectives .....	151
13.2.	Material properties testing – Tenacity .....	151
13.2.1.	General Overview .....	151
13.2.2.	Theoretical overview .....	152
13.2.3.	Experimental setup.....	155
13.2.4.	Results.....	155
13.2.5.	Conclusions and discussion.....	156
13.3.	Chapter summary .....	157
14.	Experimental Case studies .....	158
14.1.	Chapter objectives .....	158
14.2.	Sliding Door Handle.....	158
14.2.1.	Overview .....	158

14.2.2.	Current production method .....	159
14.2.3.	Objective of the redesign .....	159
14.2.4.	RM Design .....	160
14.2.5.	Results and conclusions .....	162
14.3.	Electronic enclosure A .....	164
14.3.1.	Overview .....	164
14.3.2.	Sheet metal manufacturing processes in perspective .....	164
14.3.3.	Conventional design .....	165
14.3.4.	Objective .....	166
14.3.5.	RM redesign .....	167
14.3.6.	Results .....	171
14.3.7.	Conclusions .....	172
14.4.	Electronic enclosure B .....	173
14.4.1.	Overview .....	173
14.4.2.	Conventional design .....	173
14.4.3.	Objective .....	174
14.4.4.	RM Design .....	175
14.4.5.	Results and conclusions .....	182
14.5.	Chinese South Pointing Device .....	185
14.5.1.	Overview and objectives .....	185
14.5.2.	Conventional design .....	186
14.5.3.	RM design .....	188
14.5.4.	RM of the south pointing device .....	191
14.5.5.	Results and Conclusions .....	195
14.6.	Chapter summary .....	197
15.	Conclusions and recommendations .....	199
15.1.	Chapter objectives .....	199
15.2.	Conclusions .....	199
15.3.	Recommendations for further work .....	202
16.	Bibliography .....	204
Appendix A – Detail analysis of spring mounted keys .....		212

Appendix B – Detail analysis of LS snap-hooks .....	214
Appendix C – Journal Articles .....	216
C-1. Designing For Rapid Manufacture .....	216
1.    Introduction and problem statement.....	217
1.1. Introduction .....	217
1.2. Problem statement.....	218
1.3. Objective .....	218
2.    Challenging existing manufacturing paradigms and considering novel abilities and restrictions of rapid manufacture .....	219
2.1. Conventional manufacture versus rapid manufacture .....	219
2.2. Novel abilities of rapid manufacture .....	220
2.2.1. Geometric design freedom .....	220
2.2.2. Free complexity .....	220
2.2.3. Adding value to products through innovative design.....	220
2.2.4. Absolute accuracy .....	221
2.2.5. New manufacturing paradigms.....	222
2.2.6. Digital distributive production .....	222
2.3. Restrictions imposed by rapid manufacturing.....	223
2.3.1. Surface finish, and build times .....	223
2.3.2. Material restrictions.....	224
3.    The impact of rapid manufacturing on the product development process .....	225
3.1. The impact of rapid manufacturing on the design for manufacture and assembly.....	225
4.    Delineation of design for rapid manufacture guidelines .....	228
5.    Conclusions and further work .....	232
6.    Bibiliography .....	234
C-2. Designing For Laser Sintering .....	237
1.    Introduction .....	238
1.1. Introduction and problem statement .....	238
1.2. Methodology and Objective .....	238

2.	Selection and analysis of representative conventional and rapid manufacturing processes .....	239
2.1.	Selecting a predominant rapid manufacturing process .....	239
2.2.	Selection of a representative conventional manufacturing process and analysis of its abilities .....	243
3.	Delineation of design for laser sintering guidelines .....	250
4.	Conclusions and further work .....	256
5.	Bibliography .....	258

## LIST OF FIGURES

Figure 2-1: A flint knife .....	9
Figure 2-2: A Watt steam engine .....	11
Figure 2-3: The concurrent design process .....	16
Figure 2-4: The product development process .....	17
Figure 5-1: The injection moulding process.....	61
Figure 6-1: The conventional product development process.....	66
Figure 7-1: Reducing the wall thickness.....	72
Figure 7-2: Use ribs to minimize heavy sections and keep wall thickness uniform.....	73
Figure 7-3: How to design corners.....	74
Figure 7-4: Flow configuration.....	76
Figure 7-5: Design to reduce restriction due to change of direction .....	76
Figure 7-6: Differing weld lines developed by different flow patterns....	78
Figure 7-7: Concealing a parting line.....	78
Figure 7-8: Parallel draft surfaces can keep wall thickness uniform.....	79
Figure 7-9: A basic guideline for rib design .....	81
Figure 7-10: Examples of geometric structural reinforcement.....	82
Figure 7-11: Sidestepping undercuts .....	83
Figure 7-12: Basic guide for blind-hole design .....	85
Figure 7-13: Design guide for bosses .....	89
Figure 7-14: Design guide for bosses .....	90
Figure 7-15: Common snap-fits: A, a snap-fit with spherical undercut. B, a snap-fit with cylindrical undercut and mating lip and C, a snap-fit with flexible cantilevered lugs .....	90
Figure 7-16: Designing cantilevered lugs .....	92
Figure 7-17: Living hinge design.....	94
Figure 7-18: A successful living hinge design.....	95
Figure 8-1: A schematic representation of the selective laser sintering process. ....	109

Figure 9-1: The product development process .....	111
Figure 9-2: A linear representation of the RM product development process .....	120
Figure 12-1: The original Bafbox product.....	138
Figure 12-2: Preliminary design sketches .....	139
Figure 12-3: The finalised CAD model.....	140
Figure 12-4: The final SLA product .....	141
Figure 12-5: CAD representation of a front plate of a diesel fuel injection system. ....	145
Figure 12-6: A sectional view through the diesel injection system. ....	146
Figure 12-7: A sectional view through a SLA front plate of a diesel injection system.....	147
Figure 12-8: An optimised RM diesel injection system design compared to a conventional design.....	148
Figure 13-1: The primary build orientation in an LS build envelope. ...	155
Figure 14-1: Injection moulded door handle .....	159
Figure 14-2: Sketch showing the undercut and snap-fits of the RM door handle.....	161
Figure 14-3: A CAD rendering of the final handle design in comparison with the actual LS part. ....	162
Figure 14-4: The conventional manufactured sheet metal enclosure .....	166
Figure 14-5: The CAD models of the parts of the redesigned enclosure.....	168
Figure 14-6: A CAD rendering of the assembled product .....	168
Figure 14-7: The LS model of electronic enclosure A .....	172
Figure 14-8: Spring mounted keypad and undercut snap-hooks .....	177
Figure 14-9: A spring-mounted key .....	178
Figure 14-10: A back view of electronic enclosure B.....	180
Figure 14-11: A CAD representation electronic enclosure B.....	181
Figure 14-12: Two exploded views of the electronic enclosure B assembly.....	181
Figure 14-13: The actual RM model of electronic enclosure B.....	182



Figure 14-14: A reproduction of a south pointing chariot.....	185
Figure 14-15: The CAD model of the RM south pointing chariot .....	191
Figure 14-16: The first model of the differential gearing system .....	192
Figure 14-17: The RM model of the wheel bearing .....	194
Figure 14-18: The revised differential gearing system .....	194
Figure 14-19: The complete RM south pointing device .....	195

## LIST OF TABLES

Table 3-1: Comparison of the impact strength of a mechanically introduced notch and a RM manufactured notch.....	43
Table 3-2: A comparison of the abilities of conventional manufacture and rapid manufacture technology .....	44
Table 4-1: Comparison of the abilities of laser sintering and stereolithography .....	55
Table 7-1: Guiding principles when designing for injection moulding....	96
Table 11-1: High order design for manufacture guidelines .....	127
Table 11-2: Guiding design parameters for RM.....	128
Table 11-3: Design for laser sintering guidelines .....	131
Table 12-1: A comparison of the RM and original Bafbox.....	140
Table 12-2: Comparison of features offered by RM and conventional manufacture .....	148
Table 3-1: A comparison of the abilities of conventional manufacture and rapid manufacture technology .....	227
Table 4-1: Guiding parameters for DFRM.....	230
Table 2-1: Comparison of the abilities of laser sinter and stereolithography .....	242
Table 2-2: Design for injection moulding guidelines [1] [11] [13] [14] [16]. .....	244
Table 3-1: Guiding parameters when designing for laser sintering .....	251

## LIST OF EQUATIONS

### 12.1 Modulus of Elasticity or Young's Modulus

$$E = \sigma / \varepsilon$$

### 12.2 Ultimate tensile strength

$$\sigma_s = F_{max} / A$$

### 12.3 Percentage elongation

$$\% \text{ elongation} = (l - l_0) / l_0 \times 100\%$$

## SYMBOLS, ABBREVIATIONS & ACRONYMS

### *ABBREVIATIONS AND ACRONYMS*

CM	Conventional manufacture
DFMA	Design for manufacture and assembly
DFRM	Design for rapid manufacture
IM	Injection moulding
LS	Laser sintering
LED	Light emitting diode
PCB	Printed circuit board
RM	Rapid manufacture
RP	Rapid prototyping
SFF	Solid freeform fabrication
SLA	Stereolithography
SLS	Selective laser sintering

### *SYMBOLS*

A	Original cross-sectional area
b	Thickness of the web of a living hinge
E	Modulus of elasticity/Young's modulus
$F_{\max}$	Maximum applied force
L	Length of an internal hinge
l	Final length
$l$	Half the difference between the wall thickness and web thickness of an internal hinge
$l_0$	Initial length
R, r	Radius
T, t	Wall thickness

### *GREEK SYMBOLS*

$\sigma$	Stress
----------	--------

$\varepsilon$  Strain  
 $\sigma_s$  Maximum tensile strength

# CHAPTER I

## 1. INTRODUCTION

### *1.1. CHAPTER OBJECTIVES*

This chapter presented a brief description of the research topic. This description could be categorized in four sections. In the first place, a high level overview of the object that was analysed was provided. Out of this introduction a problem statement was formulated. These two paragraphs naturally lead to the characterization of a hypothesis, which finally lead to the description of the method by which this hypothesis was verified. Thus, in short, the objectives of this chapter:

- To introduce the object that was scrutinized.
- To define the problem that was the motivation behind this research project.
- To establish a hypothetical solution for the problem.
- To pen down the objectives that were achieved through this research project.

### *1.2. INTRODUCTION TO SOLID FREEFORM FABRICATION AND RAPID MANUFACTURING*

Solid freeform fabrication (SFF), or as some liked to call it, additive manufacture, was the collective name for a series of unorthodox manufacturing technologies that produced parts by “growing” them, adding material layer by layer, instead of the selective deducting, forming, casting and/or joining of material that conventional manufacturing processes required.

Apart from this revolutionary “grow-manufacture” technique, these SFF processes differed from conventional manufacturing processes in a number of other ways, but most substantially, in that it was a completely

tool-less process. This tool-less character of SFF enabled these processes to construct parts of which the geometry previously had been near impossible, extremely expensive and downright difficult to produce. No tooling complimented the versatility and flexibility of SFF, by allowing designers or producers to modify and alter the design of individual parts easily and with very limited addition to the production cost. Furthermore, this absence of tooling requirements implied the removal of all tasks concerned with the manufacture thereof and could therefore often result in a significant reduction of the duration of the product development cycle.

Given these extreme abilities of geometric freedom, versatility and speed, it was not surprising that the first industry that began reaping the benefits of SFF was the prototyping industry. Since SFF's invention in the 1980's, it had been used extensively for prototyping. It took this industry by storm; enhancing and contributing so much to the sector that prototyping without SFF had become near unimaginable.

SFF technology had also been utilized with excellent results in the tooling industry. Through rapid tooling, as this sector of the industry was often referred to, it became possible to produce tooling much faster than any conventional manufacturing technique and often at a fraction of the cost that would normally have been associated with the process.

Unfortunately, the layered nature of SFF processes, the very origin of SFF's power, could also be linked directly to most of the major problems that these manufacturing systems experienced. Amongst others, the poor surface finish and slow throughput speeds of SFF processes were often identified as the major hurdles that the technology had to overcome before it would be recognised as a true manufacturing process [16]. However, years of development and improvement of SFF systems reduced these

problems to such an extent that most of them could now be tolerated and some even sidestepped.

In recent years, SFF technology had developed to a level where the quality of the SFF prototype parts could begin to compete with parts that were produced in conventional production runs, resulting in the rise of a new field of applications and uses for SFF technology. Apart from all the problems and criticism that this new field, appropriately named rapid manufacturing or simply RM, was experiencing, it was constantly growing and proving its worth amidst the ranks of more mature conservative manufacturing techniques. It became apparent that true tool-less rapid manufacture was no longer a dream out of a science fiction film, it had become reality.

Considering this uniqueness of SFF technology, the outstanding abilities thereof and the tremendous possibility that flowed forth, it followed logically that, in order to harness its full potential, certain modifications would have to be made wherever conventional manufacturing processes were replaced by SFF systems. One had to realize that these amendments would not be limited to the substitution of one manufacturing process for another, although this change was the direct source of all other modifications. A radical change of manufacturing process, such as the transition to SFF, would have had a profound impact throughout the entire product development cycle and was prone to transform certain long accepted ideas regarding design, production and even distribution and inventory.

### *1.3. PROBLEM STATEMENT*

Unfamiliarity of a designer with aspects, such as the novelty of the rapid manufacturing paradigm, the whole series of new abilities and unique problems associated with RM, that had to be considered throughout the



design of parts intended specifically for rapid production, would inevitably have lead to less than optimal exploitation of RM. Consequently, there was a definite need for the delineation of structured conventions, similar to conventional design for manufacture and assembly guidelines that indicated how a design problem that incorporated RM as part of the solution would be approached in order to obtain maximal results.

#### *1.4. HYPOTHESIS*

It was possible to produce end-use parts and products by making use of SFF technologies. These rapid manufactured parts were not suitable for all applications, but in some cases and under certain conditions it proved to be a better solution for the problem than conventional manufacturing processes.

In order to produce high quality SFF parts consistently, it was necessary to describe the design process, the paradigm shift that went along with good SFF design and the design for rapid manufactur rules or guidelines for SFF.

This formal description of DFRM guidelines for SFF was to enable designers to create parts that had better characteristics, such as surface finish and accuracy, thus delivering RM products that were more competent and competitive, in comparison to other conventionally manufactured products.

#### *1.5. OBJECTIVE*

To create a matrix of design for rapid manufacture (DFRM) guidelines, it was necessary to establish what the novel abilities of RM were and what restrictions it imposed. Furthermore, an impact study had to be done that could ascertain the relevance of existing ideas and principles related to manufacturing in this new manufacturing domain. Guiding principles

extracted from these analysis could then be blended together to construct a high order frame of DFM guidelines that was relevant regardless of the RM process employed. Similar analysis of the abilities of specific RM processes and process specific design for manufacture (DFM) guidelines of comparable conventional technology provided lower order DFM guidelines that supplemented the higher order parameters, thus creating a set of specialized, process specific DFRM guidelines that could help industrial designers and engineers conceive designs that were apt for RM.

### *1.6. CHAPTER SUMMARY*

SFF was a fundamentally different manufacturing process that did not conform to the conventional method of manufacturing. The tool-less nature of solid freeform fabrication techniques gave these processes the ability to manufacture designs that were not feasible through any other manufacturing technique. Unfortunately SFF was not a super manufacturing process and like all other manufacturing processes, did have a number of inherent drawbacks.

However, development through recent years had enabled certain SFF processes to reach a level of maturity where the parts produced could begin to rival the production parts that were produced by conventional manufacturing techniques. This meant that true RM of end-use parts was absolutely possible.

Since SFF was such a radical manufacturing process, it was believed that product development for RM could not be implemented on the conventional product development model without first introducing significant changes to the structure.

One of the significant changes that had to be incorporated in order to exploit RM to the maximum involved the method by which designers

approached a RM design and the technique by which the designers actually designed the product. These modifications to the way that designers work, was overwhelming and lead to designs that were less than optimal. As SFF was implemented more and more often for the manufacture of production parts, a need for some sort of guidelines that could support designers who design for RM developed.

It was believed that a framework of design rules that defined the sphere where RM could be implemented with success could enable designers to produce better SFF designs consistently.

The objective of this research project was to address this problem by creating such a set of DFRM guidelines. In other words, during the course of this study such a framework was created by analysing the novel abilities and shortcomings of SFF processes and comparing it to the abilities and limitations of similar conventional manufacturing processes.

## CHAPTER II

### 2. PREAMBLE

#### 2.1. *CHAPTER OBJECTIVES*

This chapter set the field upon which the entire research project was played out. In more specific terms, conventional manufacturing processes were discussed in broad terms and a definition for conventional manufacture was established. Similarly solid freeform fabrication and a model for the conventional product development process were introduced. All three these discussions reinforced the claims that were made in Chapter I, but also provided the foundation upon which this research project was based, thus it was essential that a thorough understanding of the subjects had to be established. Accordingly, the objectives that were achieved in this chapter could be summarized as:

- Conventional manufacture was discussed and a definition for the term was derived.
- A definition of solid freeform fabrication was presented and information regarding the process was provided.
- A model for the conventional product development process was introduced.

#### 2.2. *DEFINING CONVENTIONAL MANUFACTURE*

How can conventional manufacture be defined? Before any concise answer could be given to such a question, it was important to establish a broad understanding of the feature or process upon which the attempt was made. Any attempt made prior to the gain of such knowledge will always be a foolhardy enterprise and this attempt to define conventional manufacture was no exception. Thus, it was imperative to understand what was meant by the term conventional manufacture, before pinning it down in a single paragraph or phrase.

According to Rhoades [33], there were four fundamental manufacturing processes that were used, in different combinations and sequences, throughout the entire manufacturing industry in order to manufacture nearly all discrete parts. These four fundamental processes were casting or moulding, forming, machining and joining.

*Casting or moulding* produced objects by the solidification of liquid material in a special preformed container or mould. A material in liquid form was poured or injected into the mould, allowed to solidify, normally by cooling, but sometimes by heating or chemical curing and then removed from the mould as a solid object. The mould was typically made from a metal with a higher melting temperature than the formed material. Sometimes the mould was disposable (e.g., sand or ceramic) and was destroyed during the removal of the formed part. In these cases, the mould itself was often "moulded" from a durable, preformed master pattern.

*Forming* was a process of applying force and sometimes heat, to reshape cut or chip, material by stamping, forging, extruding, or rolling.

*Machining* described all processes that "cut" specific features or forms into preformed blanks by manipulating a cutting tool's relative position to the work piece. Machining included processes such as milling, grinding, sawing etc. Usually, many different cutting tools and processes were used to produce a single part. Computer numerical control or CNC systems were systems that could be programmed to perform various cutting procedures in a specified sequence and at different relative positions on the blank in order to produce the part<sup>1</sup>.

---

<sup>1</sup> CNC systems were similar to SFF systems in that their fabrication procedure was computer controlled, however the manufacturing procedure of SFF and CNC differed fundamentally. CNC machining was a form of subtractive manufacturing while SFF

*Joining* included welding, brazing and mechanical assembly of parts that had been made by moulding, forming, or machining in order to produce more complex parts than would otherwise be possible with those methods.

Artefacts from prehistoric times provided evidence that mankind's ability to manipulate these fundamental processes was nearly as old as man himself. The excavation of stone knives, arrowheads and other stone tools proved that the people who used such tools thousands of years ago understood the intricacies of the machining process. Similarly, earthen pottery pieces were evidence of prehistoric forming processes and digging stones, flint arrowheads and stone axes prove that of prehistoric man understood the joining process. The following figure was a picture of an exquisite example of a flint knife that was on exhibition in the London Museum. Note the uneven surface where material had been chipped away by a very primitive method of machining.



*Figure 2-1: A flint knife*

---

was an additive manufacturing process. Thus, in accordance to the definition of conventional manufacturing, CNC was a conventional manufacturing process that could, at the utmost, be considered a distant relative of SFF.

Millennia of development on various different fronts rendered the stone-age tools, materials and products outmoded<sup>2</sup>. Discoveries such as bronze, iron and steel caused manufacturing techniques to adapt and change, however the four fundamental processes did not change. These processes were developed and became more refined but their essential fundamental principles were never altered.

During the eighteenth and nineteenth centuries an economy that was based on manual labour was replaced by one dominated by industry and the manufacture of machinery. Although this so-called industrial revolution had its roots firmly set in the production and manufacturing industries, the dramatic changes it caused were felt far beyond this domain, in fact its effect was so profound; it overthrew entire social systems [28].

During this time, the manufacturing industry became mechanised and the innovations of production lines, factories and mass production were conceived. Steam engines invented and manufactured during this time, such as the one in Figure 2.2 [28], provided a power source that could drive heavy machinery, thus enhancing efficiency and productivity. Regardless of all the commotion, the fabulous mechanical equipment that was developed during this period were merely tools that enabled people to cast, form, join and machine raw materials more efficiently.

---

<sup>2</sup> Contrary to common perception stone tools were still commercially available and were used for surprising applications. Delicate surgery ranked high amongst current applications. It was said that incisions made by stone scalpel healed faster and caused less scarring. This was largely due to the fact that obsidian, the volcanic glass that was primarily used for the production of surgical scalpels, could produce a cutting edge that was a hundred times sharper and much smoother than stainless steel scalpels [32].



*Figure 2-2: A Watt steam engine*

Since the industrial revolution, tremendous amounts of time and money were spent on development and refinement of manufacturing and production systems. Known manufacturing systems were studied in order to determine the extent of their abilities and new manufacturing systems were developed in order to satisfy the need created by the inability of others. Today computers and robots form part of specialized and optimised production lines, and yet, regardless of all the automization, complexity and tremendous throughput rates that these systems attain, the processes were nothing other than combinations of the four fundamental manufacturing processes that, through years of use and painstaking research, have been honed to perfection. In the end, it does not matter whether a flint knife was used to cut to cut leather or a computer-controlled laser to cut fibre reinforced polymers, the basic principles of the cutting process were exactly the same although the material and process differ substantially.

Thus, as it was now proved that the four fundamental manufacturing processes and their associated approach toward design and manufacture had been known since the Neolithic age and used ever since, have these processes not earned the right to be named conventional?



Conventional manufacture can therefore be defined as any manufacturing process that involved any one or any combination of the four fundamental manufacturing processes, with the four fundamental manufacturing processes being casting, forming, machining and joining. Hence, the conventional approach toward design was a mindset that complied with the rules of manufacturing and design that were stipulated by the four fundamental manufacturing processes.

### *2.3. AN INTRODUCTION TO SOLID FREEFORM FABRICATION*

Solid freeform fabrication (SFF), additive manufacturing and layer manufacturing were three synonym collective names for a set of non-conventional technologies and processes used to manufacture models directly, without the need of any tooling, from three-dimensional (3D) computer-aided design (CAD) models by constructively building the part in layers [35] [55] [37]. This tool-less nature of most, but not all, SFF techniques was their reason for existence and their primary advantage. In conventional manufacture, the need for tooling represented one of the most restrictive factors for today's product development, thus the absence of tooling within SFF meant that all those restrictions could be ignored, enabling SFF to create parts of virtually any complexity of geometry [24].

The first commercial SFF process, stereolithography (SLA), was developed in 1986 [1] and presented at the AUTOFACT show in Detroit, MI during November 1987 [58]. Subsequently, several other SFF processes were developed during the late 1980's and 1990's. At the time of writing more than 920 patents on these technologies were awarded in the United States alone [35]. Many of these processes never gained any popularity among users and gradually disappeared. In contrast, processes such as SLA, selective laser sintering (SLS) or laser sintering (LS) as it was increasingly being called [35], laminated object manufacturing

(LOM), fused deposition modelling (FDM) and 3D printing (3DP) that were more suited for higher volume production, gained in popularity.

The first of these SFF technologies were intended solely for application in the prototyping industry [58]. In this industry SFF made a phenomenal impact, revolutionizing the entire industry and propelling it into the twenty-first century with a bang. The idea of prototyping without, rapid prototyping (RP), as SFF prototyping became known, was rapidly fading. Since its introduction, SFF had proved time and again that its ability to produce low volume, customized products quickly, easily and economically could not be surpassed by any current technology. Rapid prototypes that were currently used ranged from functional models to fit/assembly prototypes to patterns for prototype tooling.

Like all manufacturing processes, SFF had a number of inherent drawbacks and limitations. Research and development resulted in a definite degree of improvement to most of these burdensome aspects [61] [26] but, in spite of the promise of significant future development, the reality was that some of these problems were more than likely to remain.

In spite of these problems, rapid manufacturing (RM) was evolving from the more mature RP technologies [23], and contrary to criticism, there were a growing number of success stories where SFF technology was implemented to produce production parts. RM had shown the inclination to succeed in areas where unit cost was high, production volume was low and parts were small and hidden from view [16], and the results were often staggering. It was unlikely that RM would rival the production scales of current automated conventional processes in the near future, but that did not matter. Not all industries demanded parts in volumes of tens of thousands.

It was predicted that in the future rapid manufacturing would supersede the way that many products were manufactured [22]. SFF and RM promised to change the way people thought about design, manufacturing and product distribution completely. In fact it was believed that the influence of RM would be so profound that it would not only be felt in the manufacturing industry, it was bound to influence the entire design and development cycle, production line and even the way consumers buy products. According to Wang, Phil Dickens, a professor at Loughborough University in the United Kingdom predicted that: “The impact of rapid manufacturing will be so profound, changing the way products are designed, manufactured and distributed, that it can be described as the next industrial revolution [33].” Unlike the first industrial revolution, which led to a migration to population dense cities, this revolution would enable people to live where they like and produce whatever is required locally.

## *2.4. THE PRODUCT DEVELOPMENT PROCESS*

### *2.4.1. INTRODUCTION*

In one of the preceding sections it was mentioned that the impact of rapid manufacture would not be confined to the manufacturing phase of the product development process alone. It was expected that RM would exert its influence throughout the largest part of this process, and since SFF was such a revolutionary manufacturing technique, it can be expected that RM would upset some fundamental principles. Such dramatic changes in the product development process would, without doubt, have an effect on the DFM guidelines that are specific to RM. For this reason it was imperative that the conventional product development process was clearly defined before the impact that RM will have on it, was examined in later chapters.

#### 2.4.2. THE PRODUCT DEVELOPMENT PROCESS

Although the potential opportunities to be realized in development of new products and putting them to market were exciting, making them happen was a demanding challenge that involved a series of interlinked phases that added up to transform the idea into a physical product. This series of interlinked actions was commonly referred to as the product development process.

Traditionally the product development process was a linear process consisting of a number of tasks that began with the identification of a problem and ended with the full-scale production and distribution of the product [3] [30] [5]. In such a development process the design moved through each consecutive step in a sequential manner; however if problems were encountered, the process may be returned to a previous step.

Individual development projects were usually not done in isolation, but interacted with other projects and had to fit in with operating organization to be effective. Additionally new products might require compatibility in design and function with existing products. As the complexity of products and their need for compatibility with other products or parts increased, the efficiency of the traditional linear approach to product development decreased.

To improve the efficiency and speed of the product development process, many companies used concurrent engineering approaches to organize the projects. Rather than the simple serial approach that followed from one phase to another, concurrent engineering involved cross-functional integration and concurrent development of the technical and non-technical functions of design and manufacture within a business. Concurrent engineering was a non-linear approach to design that brought together the

input, processes and output elements necessary to produce a product [5]. The people and processes were brought together at the very beginning, which was not normally done in the linear approach. Many companies were finding that concurrent engineering practices resulted in better, higher quality products, more satisfied customers, fewer manufacturing problems and shorter cycle time between design initiation and final production.

Figure 2.3 illustrated the concurrent approach to engineering design. The three intersecting circles represented the concurrent nature of this design approach. These three activities were further divided into smaller segments, as shown by the items surrounding the three circles.

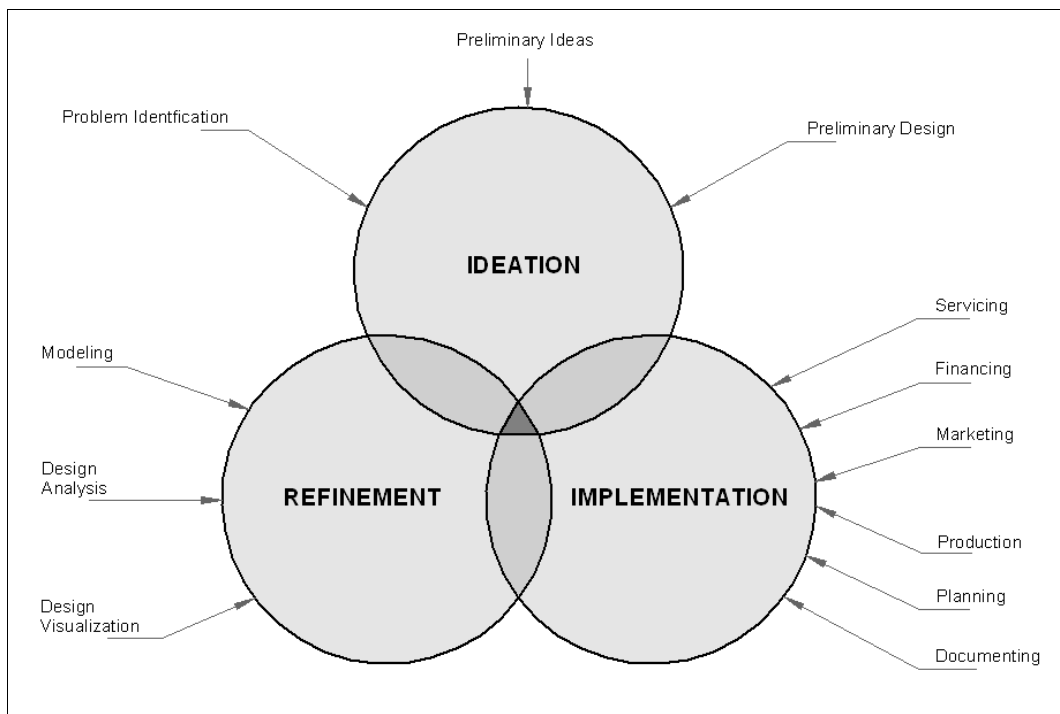

*Figure 2-3: The concurrent design process*

Although the linear product development process was mostly outdated, for simplicity's sake this described concurrent product development process was adapted and transformed into such a linear model. This made it

possible to follow the process through all the different stages, one phase at a time. Figure 2.4 illustrated the adapted product development process.

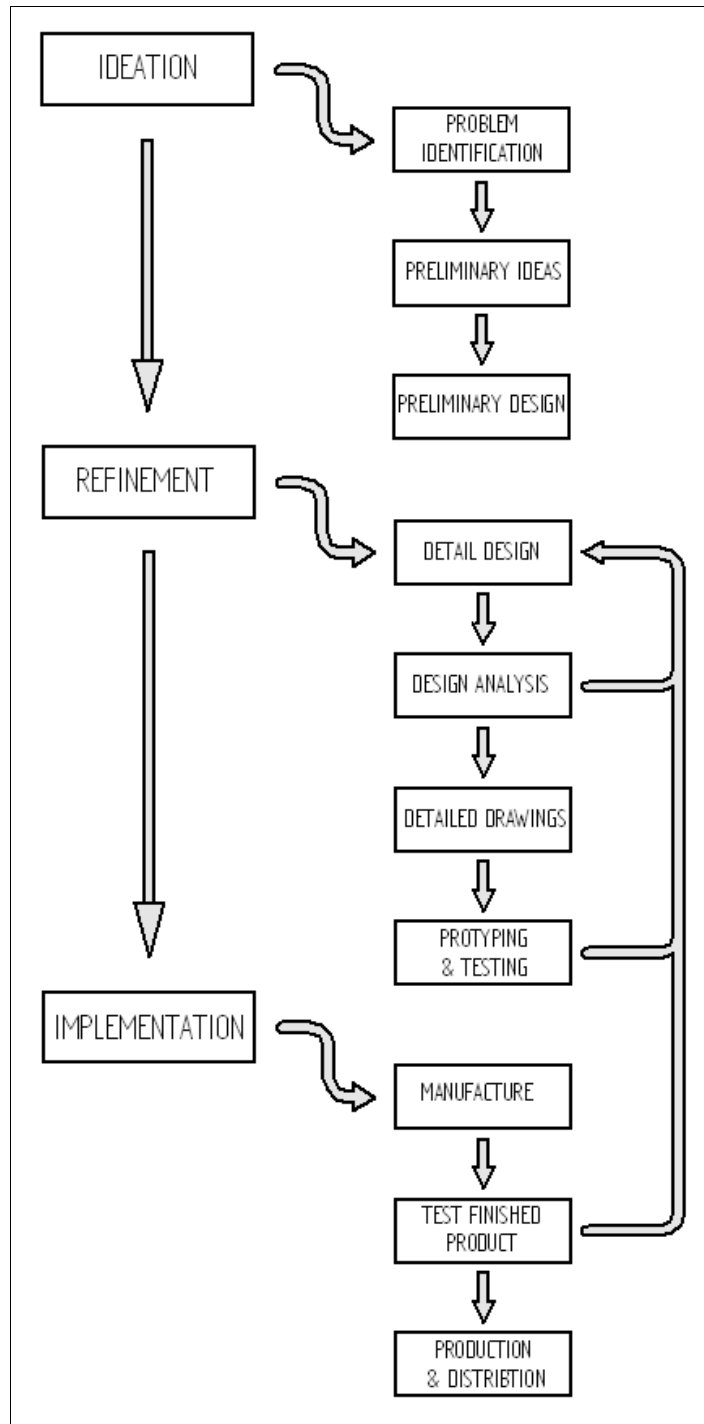

Figure 2-4: The product development process

#### *2.4.2.1. Ideation*

Ideation was a structured approach to thinking for the purpose of solving a problem [5]. During this phase of the design process the first basic solution for the design problem was conceived. Feasibility studies were often performed to define the problem, identify important factors that limited the scope of the design, evaluated anticipated difficulties and considered the consequences of the design. The ideation process consisted of three important steps namely: problem identification, preliminary ideas and preliminary design [5].

- *Problem Identification*

Problem identification was an ideation process during which the parameters of the design project were set before an attempt was made to find a solution to the design [5]. Engineering design problems had to be clearly defined before the design process could begin [30]. To create a proper problem definition required input from customers, marketing, management and engineering. Data had to be gathered to determine consumer needs, competition was surveyed to benchmark a product line and journal and trade magazines were reviewed for reports on developments in related technologies.

Once the problem statement was defined and the research and data gathering completed, objectives were developed. Objectives specifically stated what had to be accomplished during the design process and could include factors related to marketing, manufacturing, materials and other areas.

Problem identification also included a statement of limitations or constraints in the project. These constraints could take on any form but were often associated with factors such as time, material, size, weight, mechanical properties, environmental issues and cost.

The last stage in problem identification was scheduling of the design activities into a sequence that would ensure that the project was accomplished in the most effective way.

- *Preliminary ideas statement*

Once the design problem was defined, development of preliminary ideas for solving the problem could commence. Development of preliminary ideas or brainstorming, as it was sometimes called, was a process used to identify as many solutions for a design problem as possible [5]. Ideas were suggested freely without criticism or discussion of feasibility. Brainstorming resulted in a list of ideas, along with some preliminary sketches of possible solutions. The number of ideas generated depended largely on the complexity of the design and the amount of time and resources available. Eventually a few ideas were selected for further analysis.

- *Preliminary design*

After brainstorming, the ideas were evaluated, using as the criteria the problem statements, project goals and limitations. In some cases this evaluation required industrial designers to create preliminary models out of foam or other material [5]. After evaluation, one concept design was chosen that was subjected to further development. The choice for the design could be easy if only one design met the criteria. However there was frequently more than one viable design solution. When this happened the selection was made by means of an evaluation table, which was used to score each idea relative to the goals of the project.

#### 2.4.2.2. *Refinement*

Refinement was a repetitive process that was used to generate and test the design so that necessary changes could be made and until the design met



the goals of the project. Refinement was the second major stage in the engineering product development process and consisted of four main areas: Detail design, design analysis, generation of detail drawings and prototyping. These areas were further subdivided into activities that ultimately result in the optimisation of the design solution.

- *Detail design*

The term design, as it was used during this phase of the product development process, was defined as the detailing of materials, shapes and tolerance of the individual parts of the product [3]. The design process was principally an extension of the preliminary design phase. During this phase detail that had been assumed in the preliminary design phase was verified. Technical detail, such as environmental issues, safety features or product manufacturability, which had been ignored or only lightly touched during the preliminary design phase, was also attended to. This tendency to design parts and products with consideration for all interacting issues in marketing, design, production, distribution and retirement was one of the most effective approaches to implementing concurrent engineering [3] [5]. This approach to design was often referred to under the umbrella term design for X or simply DFX.

During the 1970's Boothroyd and Dewhurst conducted a study of design for assembly (DFA), which considered the assembly constraints during the design stages [31]. Expanded from DFA, Stoll developed the concept of design for manufacture (DFM) and simultaneously considered all of the design goals and constraints for the products that were manufactured. The implementation of DFA and DFM led to enormous benefits, including simplification of products, reduction of manufacturing and assembly costs, improvement of quality and reduction of time to market [3].

The effort to reduce total life-cycle cost for a product through design innovation had become an essential part of the current manufacturing industry. Therefore researchers now began to focus their attention on design for environment, design for recyclability, and design for life cycle etc.

Another field that benefited immensely from the DFX approach toward product design was the logistics interface of procurement, manufacturing and distribution [3]. Given the heavy emphasis on minimizing inventory and handling in efficient supply chains, how a product was designed and the materials that were required for manufacture could have had a significant impact on the cost to deliver the product.

However, the most influential and widest adopted DFX approaches was DFM and DFA, sometimes also referred to with a single acronym DFMA, standing for design for manufacture and assembly, and it was specifically on these two that further attention was to be focused.

- *Design for manufacture*

Design for manufacture or DFM was a philosophy or mindset in which manufacturing input was used at the earliest stages of the design in order to design parts and products that could be produced more easily and economically [3]. DFM was any aspect of the design process in which the issues involved in manufacturing the designed object were considered explicitly in order to influence the design. The results of implementing DFM had often been quite remarkable. When implemented, it was common for production cost to reduce by up to fifty percent. It had been implemented in a wide range of complex goods, including some aircraft, cars and computers. This made DFM an imperative for many marketing/assembly companies in the manufacturing industry.

A few upper level design principles for efficient manufacturing were [6]:

1. Use fewer parts. An increase in the number of parts means an increase in design and manufacturing cost. Non-existent products cost nothing to purchase, assemble and test.
2. Add more functionality per part. The goal was to accomplish the functions required with fewer parts, or to allocate more functions per part.
3. Design for ease of manufacture and fabrication. Design parts so that (a) tolerances were compatible with the assembly method employed and (b) fabrication costs were compatible with targeted production costs. This eliminated part rejections or tolerance failures during assembly.
4. Develop a modular design. Designing parts as a self-contained component with standard interface to other components.
5. Use standard components. The use of standard parts eliminates the development costs associated with designing and manufacturing.

The first rules were common among various manufacturing processes and adopted whenever possible. However, the latter rules were more comprehensive and could differ according to the manufacturing processes adopted. Most DFM guidelines were process specific.

- *Design for Assembly*

Design for assembly (DFA) was based on the premise that the lowest assembly cost could be achieved by designing a product in such a way that it could be economically assembled by the most appropriate assembly system [31]. In other words DFA techniques aimed to ease assembly and save money and time by optimising the product's geometry and other physical features for a specific assembly method. By adopting DFA guidelines at the design stage, significant reductions in time and

manufacturing cost could be achieved. Companies using DFA techniques had reported a reduction in the number of parts, the number of assembly tools, the number of assembly operations, the assembly space, the number of suppliers and the assembly time by as much as 85% [51].

The impact of DFA was felt throughout the overall design and manufacturing process [51]. For instance, the use of DFA to reduce the number of parts that were needed per product would help reduce inventory, and so reduced the inventory management effort. As a result it supported activities such as Just-In-Time (JIT) aimed at improving shop-floor performance.

In every assembled product or sub-assembly there were two major factors that influenced the assembly cost: Firstly the total number of parts and secondly the ease of handling, insertion and fastening of the part [31].

A variety of different DFA checklists and guidelines were available. These provided statements of good practice and prompted the designer to check, for example, that the number of parts in a sub-assembly was below a certain limit or that the number of different types of screws has been minimized. A few high level guidelines that were of general importance in the assembly area were the following:

1. Minimize the number of parts and fixings, design variants, assembly movements and assembly directions [6].
2. Provide suitable lead in chamfers, automatic alignment, easy access for locating surfaces, symmetrical parts, or exaggerated asymmetry, and simple handling and transportation [6].
3. Avoid visual obstructions, simultaneous fitting operations, parts that would tangle or nest, adjustments which affected prior adjustments and the possibility of assembly errors [6].

4. Make parts independently replaceable. Subcomponents of an assembly should not require removal of other components to get to faulty ones [6].
5. Assure commonality in the design. Commonality in design attempts to reduce the types of subcomponents in a system. The more standardized a product was, the less overhead associated with supporting the variety of the parts before assembly. Also the variety of tools used to assemble these types of parts could be reduced [6].
6. Assemble from a foundation. This method allowed for automated assembly by gripping to a foundation. The foundation had to be designed for accurate machine positioning, since large tolerance on the foundation location was added to the assembled components [6].
7. Assemble from as few positions as possible. Repetitive machinery was more reliable with fewer components. Reliability of the production equipment was reduced with the increase in components [6].
8. An assembly had to be ordered in such a way that the most reliable part went in first and the least reliable, last. This guideline concerned the testing of a product before shipping. If a particular component or subassembly required a significant portion of the final test, production time devoted to troubleshooting was minimized [6].
9. Minimize handling. There were two aspects to minimize handling: design of parts for ease of feeding (insertion) and design of parts to effortlessly grasp, manipulate and orientate them [6].

- *Design analysis*

Design analysis was the evaluation of a proposed design based on the criteria established in the ideation phase. It was the second major area within the refinement process. Technical analysis performed on a design included the following: Property analysis, which evaluated a design based on its physical properties such as strength, size, volume, centre of gravity, weight and centre of rotation as well as on its thermal, fluid and mechanical properties, mechanism analysis that determined the motions of the loads associated with mechanical systems made of rigid bodies and connected by joints, functional analysis which determined if the design performs the tasks and met the requirements specified in the ideation phases. Further analysis such as human factors analysis which evaluated a design to determine if the product served the physical, emotional, quality, mental and safety needs of the consumer, aesthetic analysis which evaluated a design based on its aesthetic qualities, market analysis which determined if the design met the needs of the consumer and financial analysis which determined if the price of the proposed design would be in the projected price range set during the ideation phase, could be also be done.

During this analysis stage of the refinement phase abstract predictive modelling played a very important part. An abstract predictive model was a non-physical model that was used to understand and predict the behaviour of ideas, products or processes. A finite element analysis of a 3D CAD generated mechanical part was an example of such a model, since it predicted the mechanical behaviour of the virtual part under certain specified conditions. Before expensive prototypes were built, engineers and designers often used this type of modelling to verify that the part or product complies with the objectives and limitations that were stipulated during the ideation phase of development.

If, at any time during this phase, it was determined that the design did not satisfy all the objectives and constraints that were derived during the problem identification stage, the product development process would revert to the design stage where the design was revised and improved before returning to the analysis stage for further testing.

- *Detailed drawings*

Once the design was formalized in the detail design process and approved during the design analysis process, detail drawings of the design needed to be generated. Detailed drawings were used to formally record and communicate the final design solution. With the usage of CAD much of the graphics produced in the refinement stage were in the form of 3D models. These models were used as input to the generation of detailed drawings stage to create engineering drawings and technical illustrations.

There were various different types of engineering drawings of which the most important was multi-view dimensioned drawings and assembly drawings with parts lists. These multi-view and assembly drawings were often referred to as production drawings because it was used as the communication medium between design and production or manufacturing. Production drawings contained sufficient detail for the product to be manufactured.

- *Prototyping and Testing*

Thus far, the product development process covered the design and development of a product through phases where the design solution was defined by a series of theoretical assumptions, suppositions, concepts, abstract models and drawings. The theoretical and analytical assessment that had been done up to this point, provided a certain level of confidence that all quantitative and qualitative objectives had been met, however there was also a need to evaluate the concepts and design configuration

through the use of physical components and to conduct actual tests that physically demonstrated that all requirements had been met. This evaluation could be done by the construction and use of physical working models called prototypes [6].

Prototypes inherently increased the quality and amount of communication between the developer, analyst and end-user [43]. Furthermore, prototyping reduced development time, development costs and project risk, consequently it was widely used [43] [38].

Prototyping was often treated as an integral part of the product development process [38]. This supported iterative transition between the phases of prototype testing and detail design that was normally required when problems and design inefficiencies that were identified during prototype testing had to be corrected. It often happened that more than one prototype is required before the prototype performed satisfactorily although the number of iterations between the prototyping and detail design phases were considerably less than the number of iterations between detail design and analysis. Then eventually when the prototype was sufficiently refined and met the functionality robustness, manufacturability and other design goals the design could be signed off and the actual production began.

Prototyping traditionally was a well-established area within manufacturing companies employing highly skilled machinists and fine craftsmen. The introduction of rapid prototyping (RP), the use of SFF technology to produce prototype parts, dramatically enhanced this industry. The introduction of RP processes significantly reduced the role of the conventional model maker and lead to the creation of a new group of specialized personnel that were trained specifically for this aspect of the product development process. Although RP had a dramatic effect on



the production of prototype components, it had been unable to make technical prototypes in the end-use material. These technical prototypes were therefore often produced by so-called ‘soft’ or ‘rapid tooling’ methods.

#### *2.4.2.3. Implementation*

Implementation was the third and final phase in the product development process and was the phase where the final design was transformed from an idea into an actual product, process or structure. The goal of this phase was to make the design solution a reality for the enterprise and the consumer. At this point the design was finalized and any changes became very expensive. The implementation process included nearly every phase of the business amongst others planning, production, financing, marketing, service and documentation.

- *Manufacture of tooling, set-up of numerical control programming and training*

During this phase all the machines and jobs necessary to create the product were scheduled and all numerical control (NC) and computer numerical control (CNC) programs required either for tool production purposes or product manufacturing purposes were created and tested [5] [35]. This phase also included the design and manufacture of all part specific tooling such as moulds or dies, the programming of numerical controlled (NC) machinery and other automated manufacturing equipment, the training of personnel and the verification of the supply line [35] [3].

- *Final product testing*

Once the commercial production process was set up, pilot units were manufactured using this process [3]. Production of these units enabled manufacturing engineers to test the production process and hone it for optimal performance.

Designers used these pilot units for final testing [3]. These tests were conducted to verify that the final end-use product could indeed do all that it was designed to do. If problems were identified during this phase the process had to revert all the way back to the detail design phase [35]. This was an extremely expensive exercise. Unfortunately, in some cases it was unavoidable, and could only be rectified by re-running the largest part of the product development process. On the other hand this proclaimed the importance of proper testing and analysis during the detail design and analysis phases. However, if the product did perform satisfactorily, it could be signed off, and full-scale production could commence.

- *Full-scale production*

Production ramp-up was the final phase of the product development process [3]. By this time both the design and the production system had been refined and debugged. The production system however, had yet to operate at a sustained level of production. In production ramp-up, production started at a relatively low volume; as the organisation developed confidence in its abilities to execute production consistently and marketing's ability to sell the product the volume increased. This gradual increase in volume continued up to the point where the initial commercial objectives were met and the production line turned out full capacity. From this point onward production was in full swing.

Once the products had been assembled and tested to verify functionality, it needed only to be packaged before it were shipped to the distributors. The required packaging was dependant on the type of product and distribution process and therefore varied considerably. There were only a few fundamental reasons for packaging and labelling products [39].

The first motive for packaging was the protection and safe-guarding of the product against a variety of external factors. The products enclosed in the package required protection from damage caused by physical force, rain, heat, cold, sunlight, airborne contamination, dust and dirt, handling or any combination of one or more of these. Packaging could also be utilized to protect products from pilferage, tampering and theft.

Another reason for the use of packaging was agglomeration. Small objects were often grouped together in one package. This resulted in more efficient handling. Alternatively, bulk commodities were divided into packages that were a more suitable size for individual consumers.

Marketers frequently used packaging and labels as advertising media to encourage potential consumers to purchase the product. Furthermore, it was often employed to communicate particulars on how to use, transport, or dispose of the product as well as any other information that could have been important.

Once a product was manufactured by a supplier it was typically stored in the distributor's warehouse before it was sold. Frequently there was a chain of intermediaries, each passing the product down to the next organization in the distribution chain before it was ultimately bought from a retailer by the consumer or end-user [19].

## *2.5. CHAPTER SUMMARY*

In this chapter the conventional manufacturing process was discussed in very broad terms and from that discussion a definition of conventional manufacture was derived.

An introduction to solid freeform fabrication was presented. Key aspects that were touched in this section included SFF's tool-less nature and the fact that there were a number of inherent problems that plagued SFF and, in all probability, would continue do so for some time to come. Furthermore, it was also proved that RM was possible and that it had been implemented numerous times with great success.

A model for the product development process was presented. In order to distinguish between the various phases of the concurrent product development process, a simple linear model was derived. This model could be broken up into three principle stages namely: Ideation, refinement and implementation.

It was recognized that design for manufacturing and design for assembly forms did improve the quality and reduce the cost of products that were designed according to these conventional paradigms.

## CHAPTER III

### 3. RAPID MANUFACTURE: POSSIBILITIES AND RESTRICTIONS

#### 3.1. CHAPTER OBJECTIVES

In this chapter the novel possibilities of RM and SFF and the restrictions that were inherently part of the technology was analysed. Through this analysis the strong points of RM and SFF were identified so that these facets could be captured in the DFRM guidelines. By noting these aspects of the processes it became much easier to exploit them and thus added as much value as the RM process allowed to parts. Similarly the weaker points of RM were identified and noted in the DFRM framework as points to circumvent. Properties of RM materials were also discussed. Lastly, the abilities and limitations of RM that were uncovered in this chapter were measured against conventional manufacturing to see where RM could compete with these processes and where conventional manufacturing processes would remain dominant. Summarized, the objectives of this project were:

- To analyse the SFF and RM processes and identify the strengths and weaknesses of the processes.
- To evaluate the material properties of RM materials.
- To measure the abilities and limitations of RM and SFF against those of conventional manufacturing processes.

#### 3.2. NEW POSSIBILITIES INITIATED BY SOLID FREEFORM FABRICATION AND RAPID MANUFACTURING

##### 3.2.1. DESIGN FREEDOM

Where SFF was implemented as a manufacturing process, most of the restrictions that were laid upon designers due to the inability of conventional manufacturing technologies and the need to remove a part

from a tool, could be discarded [61] [22] [23]. This was one of the primary reasons for the existence of SFF technology [24] [8]. For parts that were moulded, this meant that aspects such as draft angles, location of split lines, constant wall thickness, etc. would no longer have to be considered in the design. Without the restriction of removing a product from a tool, designers were free to design any complex geometry desired, even if manufacture of the design by conventional manufacturing technology would be prohibitively expensive and impractical, SFF machines would be able to manufacture it [61] [23].

Another fundamental advantage of SFF was that it was capable of manufacturing virtually any complexity of geometry at no extra cost [22] [23] [27]. This was virtually unheard of. In every conventional manufacturing technique cost and complexity were directly proportional. The costs incurred for any given additive manufacturing technique were usually determined by the time to build a certain volume of part, which in turn was determined by the orientation in which the component is built, thus, for a given volume of component, it was effectively possible to obtain the complex geometry for the same rate as simple geometry of the same size [22].

SFF lent itself to further design freedom due to the fact that it did not 'freeze' the design in any part specific tooling [26]. Under normal circumstances, any significant changes that were made to a design once the tooling for a conventional manufacturing process had been made, was a process that requires the re-design and re-manufacture of the tooling. Consequently, it was a costly process that was avoided as far as possible and thus, forced a design to stagnate until it was economically viable to change the mould, or until it had to be replaced for one reason or another. SFF allowed changes to the design at any time and at minimal costs in both time and money [26].

The freeform-ability, the low cost of complexity and the lack of design stagnation were aspects that played key roles in enabling the designer to enhance a design. Three of the areas where the impact of SFF's design freedom was felt that were of particular interest were, design optimisation, part consolidation and part customisation.

### 3.2.2. DESIGN OPTIMISATION

Restrictions imposed by the inability of conventional manufacturing technology often forced designers to shift their focus from the functionality of the part towards the manufacturability thereof [23]. The limited restrictions interposed by SFF allowed designers to return their focus to the functionality of the design and not waste their efforts on other factors that were of lesser concern.

Part optimisation and maximal functionality could be attained through part design analysis. Contrary to most other engineering disciplines where it was standard practice to verify and optimise by means of mathematical models, finite element analysis and the like, this approach was not very common in the plastic part design arena, as an optimised design often proved impossible to manufacture due to restrictions enforced by the manufacturing technology. It was proposed that, due to the freedoms of design afforded by SFF, this approach of optimisation through analysis could be used much more extensively for product development and design. The design freedoms afforded by RM by means of SFF enabled increasingly complex designs to be realised that were fully optimised for the required function [27].

There was reason to believe that in the future RM technology would facilitate even further design optimisation by enabling the production of parts in non-homogeneous material [61] [23] [27]. Objects formed by conventional manufacturing processes, such as moulding, were generally

formed in one homogeneous material [27]. Even in the case of an over-moulded component, where there were two or more homogeneous materials in one finished part, there was a definite boundary between one material and the other. Some SFF processes had the potential that could be utilized in the future to mix and grade materials in any combination desired, thus enabling materials with certain properties to be deposited where needed. Given that RM potentially allowed the development of multiple materials to be deposited in any location or combination that the designer required this potentially had enormous implications for the functionality and aesthetics that could be designed into parts [22].

### 3.2.3. PART CONSOLIDATION

One of the most important opportunities that arose from the ability to 'manufacture for design' came from the very real potential to consolidate many components into one [27]. In theory SFF technology would even have enabled designers to design functional living assemblies, thus making it possible to reduce the number of parts in every assembly to just one [24]. This reduction of parts in assemblies had tremendous implications, not just for the actual assembly of the components and the consequent cost savings that was gained, but also for the potential to maximize a design of a product with the part functionality in mind and not to have compromised the design for manufacturing and assembly reasons [27].

### 3.2.4. CUSTOMISATION

The manufacture of customized parts using conventional skills and technology had traditionally been very labour-intensive and essentially craft-based. Thus, partly due to the costs of labour, customized parts were usually out of reach of the general public who were forced to buy mass-produced goods. However, through the adoption of RM technology, the era for cost effective customisation for the masses was not far off [27] [8]. It was believed that if it was possible to economically produce as few as a



single unit of an item, there would be a significant demand for products created by and for individual consumers [8].

The additive RM techniques were enabling technologies to produce more cost effective custom made products [22]. The production method and processes involved for the rapid manufacture of individual customized parts did not change from part to part [27]. Furthermore there was no need to mass-produce parts in order to amortize the costs of the tooling into many thousands of components [22]. This customisation due to RM had already become a commercial reality as Siemens and Phonak were using LS and SLA technology to produce highly customised hearing aids commercially [27].

### 3.2.5. NEW MANUFACTURING PARADIGMS

In the past, the manufacturing technology had severely restricted designers and hence forced them to become accustomed to designing relatively simple geometries [22]. As RM by means of SFF facilitated the removal of these restrictions, it had a profound effect on the way designers work. Designers were no longer forced to operate in a field that was severely encumbered by restrictions imposed by manufacturability, but were able to design complex shapes and parts that were optimised for functionality and not manufacturability, although the strict discipline that had been acquired over years of applying manufacturability constraints could be difficult to unlearn [9]. This new design freedom placed much more responsibility on the designer to think about the exact requirements of a part; with the unlimited geometry capability designers needed to be much more imaginative in order to make full use of the new manufacturing processes [22].

RM changed the division between mechanical and aesthetic design [23]. The ability of industrial designers to create the parts required without the need to consider issues such as draft angle and constant wall thickness

(needed for injection moulding) meant that, in effect, the industrial designers were able to produce end-use items rather than just design briefs that were made manufacturable by mechanical designers. Conversely, mechanical designers would be able to manufacture any complexity of product required [23]. Since these two fields, aesthetic design and mechanical design, became intertwined, it was likely that the advent of RM would lead to a new breed of unique multi skilled designers.

#### 3.2.6. DIGITAL DISTRIBUTIVE PRODUCTION

When SFF technology was implemented as manufacturing processes, true just-in-time (JIT) manufacturing became possible [61]. Through the use of RM, producers were able to step over a number of phases that had previously formed a vital part of the product development process [35] and shipped parts to customers very soon after finalizing the CAD design [61]. The very short time during which parts could be manufactured, led to the possibility of eliminating parts inventory [61]. Since the time that was required to manufacture a certain part or parts by means of RM was reduced to a few hours it was not necessary to maintain large inventories. The ‘inventory’ that was necessary would consist of containers of material waiting to be formed. In effect this meant that it was possible to decentralise all manufacturing procedures by installing systems that would receive CAD data from anywhere in the world and build parts on demand [61] [33]. This distributed digital production, a direct result of rapid manufacture, could become the antithesis of the production line and could result in a revolutionary system where people paid for the plans and not the product [33].

#### 3.2.7. MULTIPLE SAVINGS

The absence of part specific tooling in the SFF processes that were implemented for RM, led to noteworthy financial savings during the product development process. Additionally, the lead times interposed by

tooling might be removed [26]. The net result was a faster, less expensive and more flexible product development process.

### *3.3. RESTRICTIONS IMPOSED BY RM TECHNOLOGY*

#### *3.3.1. ACCURACY, DETAIL, SURFACE FINISH AND BUILD TIMES*

Accuracy, detail, surface finish and build times were all aspects of SFF that were often at a disadvantage when compared to other manufacturing processes [24] [8] [9]. Consequently, these issues had received a great amount of attention, and as a result, had seen significant improvement [26] [61]. However, in spite of all the research and improvements most of these issues were more than likely to remain, manifesting in a larger or lesser degree, thus it was important to take notice of them and their effect rapid manufactured parts. For many aesthetic applications, post processing, that could offset any benefits of RM, were required, leading to the use of alternative traditional approaches, however for many non-visible parts, such as under-the-bonnet applications, surface finish and detail was less of an issue and RM were more suitable [26].

##### *3.3.1.1. Surface finish and build times*

The issue of surface finish and build times that plagued most SFF processes were somewhat interrelated [26]. Due to the practice of stacking and bonding multiple cross-sectional layers with finite thickness, common to all additive-manufacturing processes, these processes inherently produced parts that have a stair-stepped effect [26] [10]. The stair-stepping effect could be offset by building with thinner layers, but this dramatically reduced the overall part build speed as there were consequently more layers to build [26]. Certain SFF processes even went so far as to mill every layer flat after the material had been deposited and as little as 0.075 mm layer thickness could be attained; however this slowed the building process down even more.

#### *3.3.1.2. Absolute accuracy*

Absolute accuracy was defined as the difference between an intended final dimension and the actual dimension as determined by a physical measurement [11]. A number of studies had been done over the years that compared the accuracy of SFF technologies with one another and with accepted standards. Definite progress had been made, and while tolerances were not quite at the same level as those of parts produced by CNC systems, most SFF processes were able to produce parts well within normal tolerance ranges [59] [11]. Unfortunately, it was impossible to say with any certainty that one method of SFF was always more accurate than another, or that a particular method always produced parts within a certain tolerance [11]. This was due to the fact that all SFF processes involve multiple operations, intervening energy exchanges and/or complex chemistry, unlike CNC processes, where the position of the cutting tool could be easily and precisely determined and which operated on the work piece in a very direct way.

#### *3.3.1.3. Detail*

Detail was classified in two categories, firstly resolution and secondly minimum feature size. Resolution referred to the minimum increment in dimensions that a SFF system achieved [12]. It was one of the main determining factors for finishing, appearance and accuracy, but certainly not the only one. Resolution on most RM systems was tolerably good [12]. Specially modified systems were available that produced much finer features, but were limited in the size of the parts that could be produced. Resolution was dependant on the type of SFF process that was employed, thus technologies based on powders had a sandy or diffuse appearance, sheet-based methods were considered to have a poorer resolution because the stair-stepping was more pronounced, while liquid based processes tended to have clearly defined features [12].

Minimum feature size referred to the smallest detail of an object that could faithfully be reproduced. This characteristic varied considerably from process to process and was furthermore also dependent on the type of material that was used, but it normally ranged between 0.5 mm – 0.125 mm [12]. When compared to conventional manufacturing processes, SFF often lacked the crisp, highly defined detail that could be produced by certain moulding techniques, yet for most applications SFF processes were adequate to the task.

### 3.3.2. MATERIAL CONSTRAINTS

Whilst production of parts using non-homogeneous material was still a remote possibility [8], reality reveals certain fundamental problems with RM materials, most of which were related to the global amount used.

High cost, limited variety and unknown material properties

As the quantity of material used at present was very low compared to conventional processes, the production cost was very high. At the time of writing, certain RM material were known to cost up to 400 times more than material for conventional processes. Additionally, the variety of materials available for SFF production was very limited and as the quantity sold was low, it was difficult to justify development of new materials [22].

Furthermore, designers lacked confidence in the materials that could be used for RM since SFF parts often failed to match their moulded counterparts in materials and mechanical properties [24] [26]. Even when the SFF material had the same chemical composition, and in such cases very often the same name, as familiar conventional materials, there were substantial differences in what came out of a RP system compared to the results from machining or moulding the same materials. This was partly due to the fact that material had to be in a special form to be used for additive manufacture, and secondly because SFF processes operated on it in a different way [13]. But, although the properties of SFF material were

second rate in comparison, the freeform-ability of SFF technology and the analysis tools that were available, provided ample space for the designer to design a functional part, provided that the properties of the material was known. Thus in the end, it was probably fair to say that the limitation in material properties simply lay in the fact that it was not known sufficiently rather than not good enough [26]. If designers wanted to use additive processes for RM, a comprehensive set of materials data was required to give them the necessary confidence to select the right material for the intended service environment [24].

### *3.4. RM MATERIAL PROPERTIES*

#### *3.4.1. ISOTROPIC BEHAVIOUR OF RM MATERIAL*

The highly directional nature of the layer-wise additive manufacturing processes utilized for RM, inevitably led to the question; what would the effect of this layered nature be on the material properties? To answer this question numerous tests had been conducted including tensile, flexural and impact tests in order to determine whether the solid material produced by RM processes displayed isotropic or anisotropic behaviour [24] [54]. If parts were found to behave isotropically, it meant that the build direction had no influence on the material properties. If the parts produced were anisotropic it meant that the material properties varied in different directions. Anisotropic behaviour of material forced a designer to consider the part orientation within the building envelope from the earliest stages of design in order to design the part in such a manner that critical load bearing surfaces faced in the direction of maximum strength and ensured that all other loaded surfaces were supported adequately.

The results of the above mentioned study indicated a definite amount of variation in mechanical properties of the RM parts. Although all of the RM technology that was evaluated produced parts with varying mechanical properties, not all variance exceeded the normal tolerance

range. In other words, the solid material produced by certain SFF processes displayed definite isotropic behaviour, whilst others performed decidedly anisotropic [24].

During such testing, especially when the material behaved anisotropically, one of the interesting phenomena that was observed, was that fracture generally occurred along the direction of layers. Accordingly it could be concluded that the material strength decreased with increasing build angle since the layer area decreases with build angle [54]. This implied that SFF parts should be designed with a definite build-orientation in mind that, aside from considering build time, accuracy and surface finish, it had to also optimise the mechanical properties such as tensile or flexural strength for the particular application.

#### 3.4.2. THE EFFECT OF NOTCH MANUFACTURING ON THE IMPACT STRENGTH OF RM MATERIAL

Conventional impact testing required notches to be mechanically introduced into the individual test pieces, however, it was possible to include these notches as design detail in the CAD file from which the SFF part was built, and accordingly the test samples could be manufactured without the need for any post processing. Hague et al. conducted tests where some of the directly manufactured test pieces were compared with test pieces with mechanically introduced notches. The results were that the test pieces with built in notches had significantly higher impact strength than the mechanically manufactured pieces [24]. This increase of impact strength, as determined in this experiment, could have had a great impact on the design of features such as screw threads or gears etc. For example, when a screw thread was designed into a part, and produced via a RM process, it afforded greater resistance to failure than if a self-tapping screw was directly screwed into the part. The following table, Table 3.1, summarized the results of the mentioned study [24]. Note that

the percentage of improvement was dependant on both the material and the process.

*Table 3-1: Comparison of the impact strength of a mechanically introduced notch and a RM manufactured notch.*

Material	Process	Notch mechanically introduced	Notch manufactured during build process	Percent improvement
		<i>Impact strength kJ/m2</i>		
SL 7560	SLA	2.4	5.7	137.5
Acura SI40	SLA	2.5	4.2	68
Duraform PA	LS	3.8	4.5	18.5

### *3.5. COMPARISON OF RM AND CONVENTIONAL MANUFACTURING PROCESSES*

Table 3.2 shows an inclusive summary of the abilities and limitations of RM and set them in perspective by comparing them with conventional manufacturing principles. Through this comparison it became apparent that there are fields where RM was ahead of conventional manufacture; however in the same instance it was also proved that in other key fields conventional manufacturing was and was likely to remain the leader.



*Table 3-2: A comparison of the abilities of conventional manufacture and rapid manufacture technology*

	<b>Conventional manufacture</b>	<b>Additive manufacture</b>
Design paradigm	Focus on manufacturability	Focus on functionality
Design paradigm	Mechanical and aesthetic design was discernable	Mechanical design and aesthetic design merged
Tooling	Required	Not required
Lead times	Time to design, manufacture tooling and produce end-use parts	Time to design and produce parts
Initial capital investment	Required for tooling	No tooling and capital investment
Production flexibility	Limited flexibility due to tooling requirements	Very flexible
Geometric design freedom	Constrained by need for tooling and other manufacturing technology limitations	Almost unlimited
Part complexity	Cost was direct proportionate to complexity	Volume determines cost
Forced design stagnation	Consequence of expensive tooling	No design stagnation
Design optimisation	Not permitted due to manufacturability limitations	Optimisation possible

*Table 3.2: A comparison of the abilities of conventional manufacture and rapid manufacture technology (Continued)*

	<b>Conventional manufacture</b>	<b>Additive manufacture</b>
Part consolidation	Allowed within the boundaries of process capabilities	Part consolidation possible and promoted in as far it complements part functionality
Customisation	Limited customisation. Mass production preferred	Mass customisation allowed
Production and inventory and logistics	Required	Digital distributed production was a possibility
Availability of material	Material was readily available	Limited number of process specific material
Material properties known	Extensively	Largely unknown
Isotropic/anisotropic behaviour	Isotropic	Isotropic/anisotropic depended on process and material
Non-homogeneous material	Impossible	Theoretically possible

*Table 3.2: A comparison of the abilities of conventional manufacture and rapid manufacture technology (Continued)*

	<b>Conventional manufacture</b>	<b>Additive manufacture</b>
Accuracy	Excellent	Tolerably good. Dependant on build orientation
Surface finish	Excellent	Tolerably good. Dependant on build orientation and design. Post- processing could be required
Throughput rate	Excellent	Tolerably good. Dependant on build orientation and product size

### *3.6. CHAPTER SUMMARY*

In this chapter the inherent drawbacks and novel possibilities that manifested in RM, were discussed and compared to the capabilities of conventional manufacturing processes.

It became apparent that under certain conditions the implementation of RM added significant value to products. Areas where RM appeared very powerful were flexibility, geometric design freedom, design for assembly specifically with regards to part consolidation, lack of tooling and the short product development timelines associated with RM.

Like all other manufacturing processes, RM processes were not omnipotent and could not be implemented in all cases with guaranteed

success. Just as any other manufacturing process, RM had limitations. However, if these limitations were identified and consciously compensated for in a design, increased quality of RM products could be expected. Areas where RM could not compete with conventional design processes were surface finish, known material properties, accuracy and the manufacturing throughput rate.

Although the material properties of RM parts were not known to the extent that conventional engineering materials are, the little information that was available could add a whole new dimension to design, if it was managed appropriately. The non-homogeneous material properties of RM material presented an exciting design environment that, if paired with design optimisation, could produce results that could not be imitated by any other conventional manufacturing process.

In other fields conventional manufacturing was established as the dominant manufacturing processes and it was more than likely that RM will never be able to compete in those arenas. One of these areas where RM was unlikely to be able to compete was mass production.

Lastly, the strong points, limitations and new possibilities of RM that were identified in this chapter was noted and were included in the DFRM framework that followed in the subsequent chapters; the possibilities and strong points as aspects that could be exploited, whilst the limitations were listed as points that should be circumnavigated.

## CHAPTER IV

### 4. SELECTION OF REPRESENTATIVE PROCESSES FOR CONVENTIONAL AND RAPID MANUFACTURE

#### *4.1. CHAPTER OBJECTIVES*

To add detail to the DFRM framework, it was now necessary to delve one level deeper and identify factors specific to a RM process that had an affect on the quality of a product. However, before these constraints that had to be circumnavigated and opportunities that had to be exploited to make the most out of the RM process could be identified, the actual SFF method that was employed as RM process had to be selected. As the rest of this research was built around this specific RM process, it was imperative, if this research was to be of any relevance whatsoever, that the SFF process that was identified was the current leader in the industry.

Accordingly in this chapter, the main SFF processes were compared with each other in order to determine the current predominant SFF technology that was most likely to take RM into the future. This predominant SFF technology will then be posted as a representative RM process on which all further design for manufacturing RM guidelines would be built. Once the leading process in the RM arena had been identified, a conventional manufacturing process, that was comparable to the RM process, would also be selected.

To summarize these objectives:

- Compare various SFF processes.
- Select one SFF process as representative RM process.
- Select a representative conventional manufacturing process.

## *4.2. SELECTING A REPRESENTATIVE PROCESS FOR SFF*

According to Hague, designing for rapid manufacture will be designing for selective laser sintering (SLS), laser sintering (LS) or stereolithography (SLA), since these processes or variants thereof will develop into the first true RM systems [18]. This statement of Hague and the fact that LS and SLS were essentially the same process [35], simplified the selection of a relevant SFF process significantly, since it narrowed the field down to essentially two processes. In order to make an informed choice between LS and SLA several key aspects of these two processes were compared.

### *4.2.1. MATERIAL: MECHANICAL PROPERTIES AND AVAILABILITY*

SLA was fundamentally limited to photopolymers [40] [21] [36]. This limited range of materials caused the ability of SLA to adapt to new applications to follow suit, locking designers into a narrow range of applications. The majority of these photopolymeric materials fell into the category of simulating polypropylene, ABS or polyethylene [56]. Even though the mechanical properties of these materials, especially polyethylene [56], were not far apart from the original material, the range of the material that was available was limited [40] [21].

LS, on the other hand, was a versatile process that could produce parts in various different materials. Plastic, metal, ceramics, wax, nylon, elastomers and polycarbonates were some of the material that were typically used [14] [34] [45] but these materials represented only the tip of the iceberg [40]. Theoretically, the LS process could produce parts from any material powder that could be melted [36]. Thus, a virtually endless range of materials was available to LS. This drastically increased the technology's uses and enhanced its application flexibility. The net result was that the LS system offered the greatest flexibility of any SFF system.

#### 4.2.2. SUPPORT STRUCTURES AND MULTI-LAYER PRODUCTION

When a part was created by SFF it was imperative that the part was kept absolutely still while the build process was in progress. If the part or a sector thereof, moved prior to the completion of the build, the 2D profiles from which the part was constructed misaligned, resulting in a flawed part.

As SLA parts were essentially built in liquid, support structures was needed that connected the part to the build platform and supported overhanging or island features that were produced during the build [35]. The necessity of support structures impeded SLA'S ability to achieve some of SFF's most powerful feats such as the creation of working assemblies and on the whole, SLA was more efficient when building solid structures [20]. Furthermore these support structures hindered design, especially on small and/or complex parts, and limited the capacity of SLA systems to a single layer of parts in the Z-direction.

No support structures were required for parts that were manufactured by LS since overhangs and undercuts were supported by a stationary powderbed [14]. Without the need for support structures, smaller and more complex parts were readily producible. Furthermore, the absence of support structures enabled multiple layers of parts to be loaded on top of one another. This stacking ability of LS allowed for parts to be nested into one another. Not only did this imply that it was possible to orientate the various parts in such a way that the volume of the building cylinder could be utilized optimally, it also meant that it was possible to produce functional living assemblies.

#### 4.2.3. REUSE OF MATERIAL

In SLA systems, all the uncured resin that was left in the container after completion of a build could be reused [36]. Material wastage was limited to the material that clung to the part when it was removed from the build

chamber [59] and the support structures that were broken from the part and discarded. The powder used for LS, however, was not as recyclable [4]. All powder that was used during the building process was subject to an ageing process caused by the exposure to high temperatures. This ageing process was non-reversible, so the powder was undeniably damaged and had to be refreshed by adding new powder prior to reuse. Furthermore, powder that was close to the parts or in areas that have a higher temperature tended to bake together and form lumps. This powder cake around the parts was non-reusable and had to be wasted. Under normal circumstances, this loss was added to the material cost of the part. By nesting parts into cavities and crevices left in or between surrounding parts, such wastage could be kept to a minimum. Optimal usage of space in a build envelope was achieved when smaller parts and their associated powder lump was completely enclosed in the powder lumps of neighbouring parts, and since these non-reusable powder lumps had already been accounted for, optimal usage of build envelope space in effect meant the production of free parts.

#### 4.2.4. PRODUCTION PROCESS

Because of the diverse nature of SFF processes, it was rather difficult to compare their speed of production on equal ground [36], therefore, only the different aspects of production and the possible accompanying time lost and gained was compared.

By comparing the drawing speed of the LS' CO<sub>2</sub> laser and SLA's UV laser, it was found that this speed was normally in the range of 700 mm/s for both techniques [4] [36], with only exceptional higher order SLA machines that attained faster speeds. However, the drawing speed was not the only prominent factor that determined build time, the layer thickness also played a significant role [59]. On the whole, the build speed of SLA and LS systems fell within the same range with no clear champion.



Pre-processing included the time it took to prepare the computer files for processing on the RP machine and preparing the machine for operation. It also included the creation of support structures, slicing of the STL file, and merging of files prior to the starting of the build [59]. Amongst these named procedures SLA's need for support structures and LS's marked ability to go without them was the only important difference. Post-processing usually required the time it took to clean the part, remove support structures, post cure the resin and finish the surface of the part [59]. Again SLA's disadvantage toward LS was clear. SLA required the removal of the aforesaid support and some post curing in addition to some surface finishing if that had been required. LS on the other hand, only required cooling time and breaking out of the powder bed before additional surface finishing could commence.

#### 4.2.5. MODELLING ABILITY

The modelling ability of a SFF process was categorized in three parts namely: Accuracy, surface finish and the ability to produce complex geometries.

One of SLA's strongest points lay in the quality of the produced part [34]. Parts that were produced by SLA tended to have crisp lines, high detail and were normally accurate within  $\pm 0.1$  mm [52]. The parts had a good surface finish although the stair-casing effect and flaws caused by external support structure removal necessitated finishing.

Being a thermal process, LS had a more complicated and serious problem regarding the accuracy issue, as compared to other SFF processes. The accuracy problems that were experienced with LS were mainly caused by the laser scanning system, material shrinkage and laser beam offset [34]. However, in spite of these problems LS was capable of producing parts

well within normal tolerance ranges<sup>3</sup> [34] [59] and according to Terry Wholers, as quoted by Maniolis Sherman, LS parts were fast approaching the aesthetic properties of SLA [34].

Compared to SLA parts, the surface finish of current LS parts tended to be rougher and the resolution lower. This was largely due to the fact that the powdered material retained its shape during the sintering process [32]. Stair-casing on LS parts was a common phenomenon on poorly orientated planes. Accordingly, where LS parts were required for aesthetic applications, finishing was required. However, in the same way that LS parts' accuracy was rapidly improving, so too was the surface finish and resolution.

McMains conducted a series of tests with different SFF processes, in order to determine their ability to create complex, free form geometries [32]. In these tests LS outperformed SLA in most aspects. SLA'S need for support structures was mainly responsible for this lack of free form modelling ability. The support requirement confined SLA to single parts with limited internal geometry, whereas LS could produce complex internal geometries and even functional assemblies.

#### 4.2.6. ISOTROPIC BEHAVIOUR

Hague et al. conducted a series of experiments that were aimed to determine the isotropic/anisotropic behaviour of SLA and LS generated material. It was determined that the material properties of SLA generated solid material varied by no more than 5% [24]. Therefore it was concluded that SLA produced broadly isotropic parts and that the build-orientation of the part had a limited effect on the mechanical properties thereof. These same tests also determined that the material properties of solid

---

<sup>3</sup> According to Mc Mains a tolerance of between 0.127 – 0.762 mm can be achieved depending on the size of the part and the axis of measurement [36].

material produced by LS are dependant on the growth orientation [24], an observation that was affirmed by Thomson [54]. For the material Duraform PA, one of the materials used by Hague et al. in their study, mechanical properties varied by between 10.5 and 19%. Clearly, the variation of material properties in LS material exceeded the 5% margin that defined isotropic behaviour and consequently; solid material produced by LS behaved decidedly anisotropic, in other words the mechanical properties of parts produced on LS machines was dependant on the build-orientation [24].

#### *4.3. CONCLUSION*

Table 4.1 gave a summarised overview of the various abilities of LS and SLA that have been discussed in the preceding paragraphs. Consideration of all these abilities indicated that LS was a more powerful process than SLA. Although LS fell slightly short on accuracy and surface finish, most other factors were overwhelmingly in LS' favour. Factors such as LS' ability to produce "free" parts, its astounding ability to manufacture free form models and its diverse material range, loaded LS with aptitude and potential that outweighed all shortcomings. LS proved its worth in the field of RP and as this industry made the transition to RM, LS emerged as the premiere technology within the industry.

*Table 4-1: Comparison of the abilities of laser sintering and stereolithography*

	<b>Stereolithography</b>	<b>Laser sintering</b>
Material: Available range	Limited to photopolymers	Theoretically any powdered, sinterable material
Material: Mechanical properties	Limited due to limited material range	Unlimited
Material: Isotropic behaviour	Isotropic	Anisotropic
Support structures	Required	Not required
Reuse of production material	Completely reusable. Limited wastage	Partially reusable
Production of 'free' parts through nesting and overlapping	Impossible	Possible
Build speed	Similar to LS	Similar to SLA
Post curing	Required	-
Breakout	Removal of support structures	Full breakout required
Additional surface finishing	As required	As required
Cooling time	-	Required
Modelling ability: Accuracy	Crisp clear edges	Tolerable. Troubled by thermal changes and laser beam offset

*Table 4.1: Comparison of the abilities of laser sintering and stereolithography (Continued)*

	<b>Stereolithography</b>	<b>Laser sintering</b>
Modelling ability: Surface finish	Good, although flaws could be caused by support removal. Stair-casing was present	Compared to SLA, edges were rougher and resolution poorer
Modelling ability: Complex geometry	Restricted due to required support structures	Restricted by necessity of powder removal

#### *4.4. SELECTION OF A PROCESS TO REPRESENT CONVENTIONAL MANUFACTURE*

The range of polymeric parts that were currently produced by LS were comparable to products that were manufactured by the process of plastic injection moulding [24] [17] and since injection moulding was the world's premier thermoplastic manufacturing technology [44] it was fitting that this process would be considered as benchmark for aspiring plastic manufacturing technology.

#### *4.5. CHAPTER SUMMARY*

In this chapter the two foremost SFF technologies SLA and LS were compared. LS clearly emerged as the current leader and the process that presented the greatest opportunity for future development.

Through the comparison of LS with the SLA a number of LS's strongest points were identified. At the same time some of the process's limitations also came to light. All these points were aspects that should receive attention in a design for manufacture framework and should therefore be recorded as such.

A conventional manufacturing process that can produce parts similar to LS parts was identified. Without much difficulty the plastic injection moulding process was selected.

## CHAPTER V

### 5. DESCRIPTION OF THE REPRESENTATIVE CONVENTIONAL MANUFACTURING PROCESS

#### 5.1. CHAPTER OBJECTIVES

In this chapter a description of the injection moulding process provided. A thorough understanding of this particular manufacturing process was required before the process could be applied to the product development process. In short a description of this chapter's objective:

- To provide a description of the injection moulding process.

#### 5.2. PLASTIC INJECTION MOULDING

The first patent for an injection moulding machine was awarded to two Americans brothers, John and Isaiah Hyatt, in 1872 [29]. The idea of plastic injection moulding came forth out of a number of metal casting processes. The most prominent of these being the process metal die casting, of which the influence could easily be seen through the number of similarities between the processes.

Since 1872, large amounts of energy, time and money had been spent in refining the injection moulding process and as a result it had developed from, what now might seem a crude or primitive system, into the modern injection moulding process that we know today. One of the most significant contributions to the development of the injection moulding process was the implementation of the reciprocating screw feed mechanism.

Today, it was impossible to discuss the manufacturing processes of thermoplastic products without an in depth look at injection moulding. Around the world, injection moulding was the process that was most

commonly used for the production of thermoplastic products [44]. It was used for the production of a wide range of products, filling the whole spectrum that ranges from toys and electronic enclosures to automotive parts and kitchenware. This absolute domination of injection moulding in this particular field was quite understandable since it was well within the capabilities of the process to produce large quantities of accurate plastic parts, economically and at astounding throughput rates, with minimal scrap losses and low labour costs [57]. Unfortunately, the tooling and machinery requirements associated with this process that was essential for production normally required a substantial capital investment long before actual production commenced. Added to these expenses were the high running costs of the process [57], thus in order to justify these expenses and produce parts at reasonable prices, injection moulding was generally only used as a mass production process.

### *5.3. THE PROCESS OF PLASTIC INJECTION MOULDING*

Plastic pellets were fed into a pressure chamber that was linked to a feeder. The feeder forced the material into a preheated chamber in the feeder cylinder. From there the material was pressed through a section that contains a torpedo shape wedge, called the spreader, which ensured that the material flowed uniformly and was heated uniformly. It was in this section that the material was molten and heated to temperatures from 70 °C to 320 °C depending on the material. From this heating chamber the molten material was forced through a nozzle into the mould. The plastic solidified very soon after it came in contact with the mould.<sup>4</sup> Since the mould usually stayed cool in comparison to the material, the process was exceptionally useful for the moulding of thermoplastics. Whilst the plastic was solidifying the pressure that was exerted on the molten plastic was

---

<sup>4</sup> This rapid solidification was what rendered the speed to the injection moulding process. In a production environment the actual moulding operation could often be repeated up to six times per minute.



not removed. This ensured that no shrinkage occurred and that the mould was filled to capacity. When the part had cooled down sufficiently the pressure was removed and shortly afterwards the mould was opened to allow the removal of the part. After removal the mould was shut and the whole process repeated automatically.

There were two basic methods that were used to move the molten plastic material through the different chambers toward the mould. The first was to make use of a hydraulically driven reciprocating plunger. Such a configuration could develop a feeding pressure between 70 and 180 MPa. The plastic was heated by external heaters on the barrel and by shearing around the torpedo (spreader). This torpedo also ensured uniformity of material flow.

More recently a rotating screw delivery system had been developed. Figure 5.1 presented a sectional view through such a system. To deliver the required amount of plastic to the mould the screw of a reciprocating screw machine was supported by a hydraulic ram that pushes back when the pressure in the front of the screw build up to a preset value and the amount of melt needed for filling the mould was accumulated. At this point rotation was stopped and the hydraulic ram pushes the screw forward and thus injected the plastic into the mould while backflow was limited with a no-return valve. Screws were sometimes also used to feed compression and transfer moulding presses.

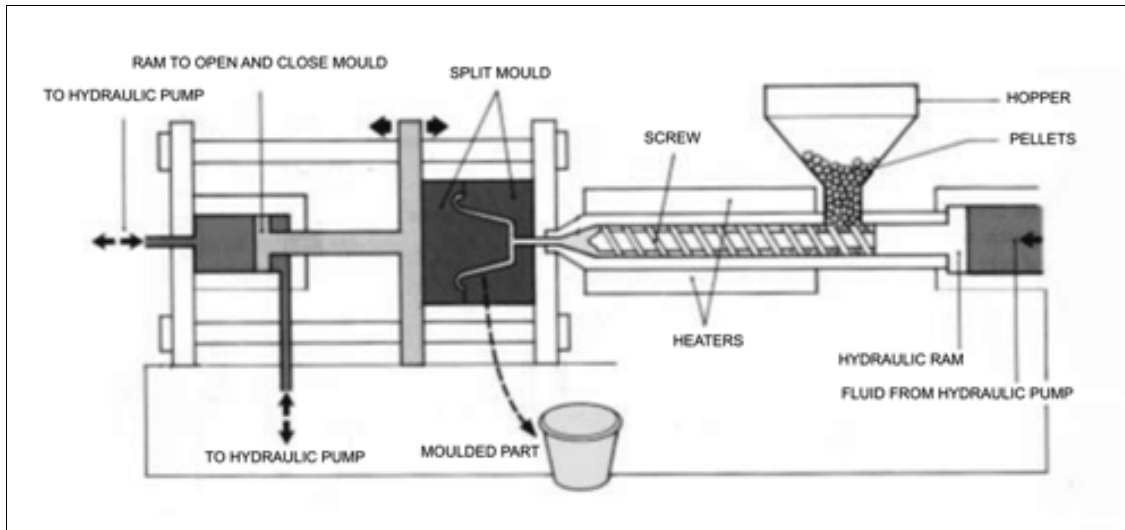

*Figure 5-1: The injection moulding process.*

For the casting of thermoplastics the material was heated to temperatures above their melting points, usually ranging from 170 to 320 °C. The temperature of the mould was kept at lower temperatures normally around 90 °C. For thermoplastics the injection pressure was typically around 140 MPa although it sometimes rose to as much as 350 MPa if products with thin walls were moulded. Under normal circumstances two to six cycles could be run per minute.

The micro-structure of moulded products was not uniform. When the molten material that was injected into the mould came into contact with the cool surface of the mould cavity, the plastic solidified so fast that it attained the orientation by which it had been injected. The granules nearer to the centre of the part took longer to cool down and consequently changed their orientation. This difference in orientation caused internal stresses in the moulded part.

For thermosets the barrel was preheated just sufficiently (70 to 120 °C) to ensure plastication. Injection under high pressures, of up to 140 MPa

generated enough heat to reach between 150 °C and 200 °C in the sprue. The mould itself was heated to between 170 °C and 200 °C.

Shrinkage of between 7 and 20% could be expected in plastics that freely cooled down [44]. However, as plastic melts are compressible, the high injection pressures not only facilitated mould filling but also stuffed the cavity, thus the shrinkage of parts is reduced significantly [44]. Shrinkage can further be accommodated by sustained pressure during the first part of solidification thus ensuring a final reduction that was often below 1% but could range up to 4% depending on the type of plastic and inert fillers [41]. Flow rates in the mould cavity could be very high and erosion by hard filler particles could, in some cases, become severe.

#### 5.4. *MOULDS*

As in the die casting process, the mould was split to allow removal of the product. Whilst the molten material was injected into the mould it had to be kept firmly shut. The required clamping force was calculated from the projected area of the mouldings and the recommended injection pressure. Ejectors were provided for removing the moulded component and fine (0.02 - 0.08 mm) vents to ensure that no air remained trapped.

As in metal casting the process was governed by the laws of fluid flow and heat conduction. Therefore feeding of the mould was critical. The system of gates and runners were the same as for casting metals. Gates should not be large enough to cause melt to flow back when the pressure was released. On the other hand, gates that were too small froze off prematurely cutting off the moulding pressure before full packing was attained. Nevertheless small in-gates (pin gates) were sometimes used to heat the plastic, reduce viscosity and aid mould filling. The number and location of gates determined the sequence of mould filling and the alignment of molecules, and thus the direction of maximum strength in the

finished part. In many configurations melt streams merged and failure to attain complete interpenetration of molecules resulted in weaker weld lines corresponding to cold shunts in metals. The low strength of plastics allowed gating solutions that would be impractical for metals. Multiple cavities could readily be accommodated, but care had to be taken to feed each cavity at the same pressure. Similar to the die casting process, the economy of the injection moulding process improved if material in the flow-distribution system was minimized. This led to the development of sprueless moulding. The nozzle extended to the mould cavity and was heated, a sudden drop in temperature shut off the flow, while rapid heat-up prevented freeze-up. In other cases a valve was used to shut off the flow.

Computer programs had been developed that could model mould filling. This eliminated the trial and error approach otherwise needed to design the optimum gating system. Mould filling was also the critical factor in terms of shrinkage and distortion. Material shrinkage differed significantly if different plastic material was used, but it was also greatly affected by part thickness and processing conditions such as temperature, injection pressure and hold time. Thicker parts solidified last consequently often caused shrink marks to develop.

Gas assisted injection moulding minimized these by injecting gas into the partially filled mould. The gas replaced the least viscous melt and forms internal cavities in thicker sections and aided filling intricate moulds.

Temperature and pressure control was critical. Machine controls had become sophisticated, allowing rapid filling of the runner system, slowing down for the beginning of injection to prevent jetting, speeding up for mould filling and holding the pressure during solidification. Commercial

programs of ever increasing sophistication helped in designing the moulds and process controls with due regard to operating and material variables.

#### *5.5. CHAPTER SUMMARY*

This chapter dealt with the process of injection moulding and although no DFRM guidelines could be derived directly out of this chapter, it provided insight into the conventional method of manufacturing products out of polymeric materials.

In the first place this provided a sharp contrast to the RM process that was discussed in Chapter VII. This contrast served to highlight the fundamental differences between the two processes and all the potential that lay ready to be excavated within the RM process, in spite of the fact that both processes delivered comparatively similar products.

Furthermore the comprehension of the injection moulding process was required as the fundamental input into the next chapter where this conventional manufacturing process was integrated into the product development process.

## CHAPTER VI

### 6. THE PRODUCT DEVELOPMENT PROCESS FOR INJECTION MOULDED PARTS

#### *6.1. CHAPTER OBJECTIVES*

The theory of the product development process that was described in section 2.3 and the theory of the injection moulding process that was presented in the previous chapter had been integrated in the subsequent paragraphs. Through this integration a reference of the conventional product development process for plastic products was developed. This reference process was later used as yardstick to compare the RM product development process with. Accordingly the objective was:

- To develop a reference model of the product development process.

#### *6.2. THE PRODUCT DEVELOPMENT PROCESS FOR INJECTION MOULDING*

Although the description of the product development processes in chapter 2 were supposed to be universal, the fundamentals of the process was so intertwined with conventional manufacturing technology, that a written paragraph on the application thereof to a conventional manufacturing process, such as injection moulding, had, for the largest part, been considered repetition. However, in spite of the risk of being repetitive, a fleet overview of the process was presented during which aspects the deserved attention was be highlighted. As the discussion that to follow referred back to the model of the product development process as it was presented in chapter 2, another copy of the process flow diagram was depicted in figure 6.1.

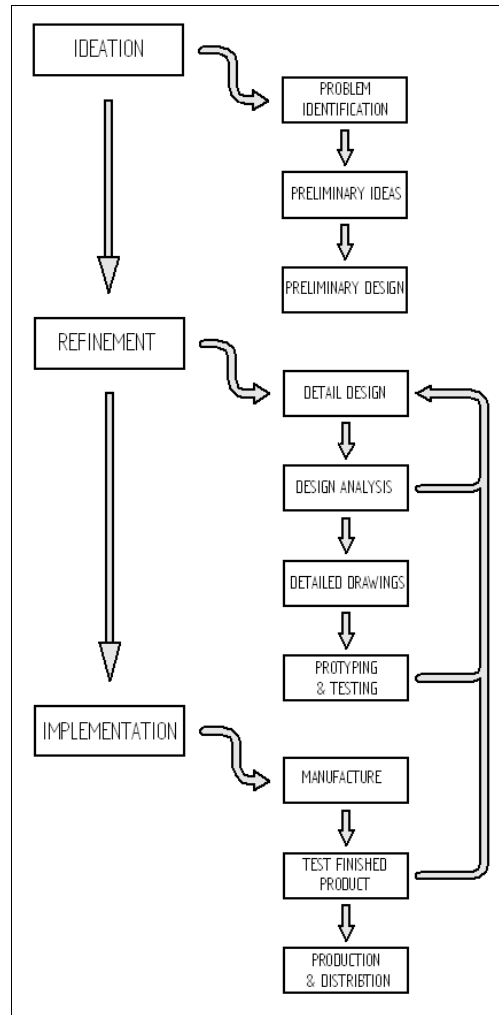

*Figure 6-1: The conventional product development process*

### 6.2.1. IDEATION

The ideation process that was pursued during the product development process of injection moulding would in all aspects be similar to the conventional process. The only process specific elements that may occur during this phase involved the consideration of injection moulding specific DFM guidelines during the evaluation of the preliminary ideas or designs.

### 6.2.2. REFINEMENT

The refinement phase of the conventional product development process underwent significant changes when injection moulding was implemented. During the first stage of the refinement stage, the detail design stage, the material from which the product was manufactured was selected. Although this selection fit into the process in the same manner that was described in the product development process described in chapter 2, it deserved to be mentioned, as it was one of injection moulding's strong points. There was an excessive amount of mouldable plastics available with properties that were thoroughly specified.

The most prominent change in this detail design stage, involves the implementation of injection moulding specific DFM guidelines during the detail design phase. These formed a clearly defined sphere of best practice suggestions within which designers was recommended to operate.

In the case of injection moulding the effect of these very well defined guidelines, often flowed over into the detail analysis phase with the effect that designers were discouraged to optimise designs, as in most cases the optimised designs were not the most manufacturable solution. In other words, in the injection moulding arena, the DFM guidelines and the manufacturability of a design often overshadowed the functionality of a design and thus resulted in a product development process that placed more emphasis on the detail design phase at the cost of the detail analysis phase.

Before the product development process for injection moulding continued to the detail drawings phase an additional prototyping phase was often introduced. During this phase, SFF processes<sup>5</sup> were often utilized to grow

---

<sup>5</sup> LS and SLA were often implemented for this purpose.



parts before any detailed drawings had been produced. This prototyping phase could, in some cases, replace the second prototyping phase; however if a second prototyping phase was required and if the prototypes that were required were to be manufactured by means of a conventional manufacturing process, it was essential that the detail drawings had to be created before this phase commenced.

Although implementation of CAD systems simplified the detail drawings phase and reduced the duration of the phase significantly, the complex designs that were allowed by the injection moulding process can have the effect that this stage become extremely time-consuming.

### 6.2.3. IMPLEMENTATION

As the diagram indicated, once the final prototyping stages were completed, the process moved on to the implementation phases. This was the stage during which all part specific tooling or moulds were produced and it often was another expensive and time-consuming exercise. The details of the production process of injection moulding had already been discussed in chapter 5 and it was not necessary to go into that detail again. However it could be pointed out again that once the tooling has been manufactured the design become “frozen” and could only be unfrozen once a decision was taken that new tooling had to be manufactured.

The manufacture of tooling phase was the only one of the three phases in the implementation stage of the conventional product development process that changed significantly when injection moulding was implemented as the manufacturing process. The last two phases of the process, final testing and production, continued in more or less the similar manner as was discussed in the earlier chapter.

### *6.3. CHAPTER SUMMARY*

A reference model was developed against which the LS product development process of subsequent chapters was measured.

Furthermore, various chinks in the armour of injection moulding were identified in this chapter. Aspects such as the detailed drawing phase, the requirements for expensive tooling and the restrictive DFM that tended to over emphasise manufacturability at the cost of functionality were points where injection moulding was particularly vulnerable.

## CHAPTER VII

### 7. DESIGN FOR INJECTION MOULDING

#### 7.1. CHAPTER OBJECTIVES

An in-depth look at design for injection moulding guidelines was presented in this chapter.

The objective of this chapter was:

- To establish a DFM framework of the conventional manufacturing process that produced parts that were similar to those produced by the representative RM process.

#### 7.2. DESIGN FOR MANUFACTURE GUIDELINES FOR INJECTION MOULDING

The primary difference between the afore described detail design phase and the detail design phase of parts that were designed to be manufactured by means of injection moulding, was that the later required the addition of DFM guidelines that were much more extensive and specialised. When a designer designed parts expressly for injection moulding, familiarity with the mouldable plastics and their unique advantages and disadvantages were required, as well as information related to the physical capabilities of the production method. From this information regarding the process' capabilities a list of process specific DFM guidelines were compiled that were to be used in conjunction with the higher order DFM guidelines that had already been discussed.

As with all DFX approaches it was imperative that the designer should follow these guidelines from the earliest stages of design. Such an approach toward the design not only resulted in tremendous savings on

tooling, it also enhanced the reliability of the product and honed its physical features into effective and producible solutions.

In the following paragraphs the DFM guidelines for injection moulding was discussed.

#### 7.2.1. WALL THICKNESS CONSTRAINTS

Heavy walls caused a lessening in mechanical properties. This was caused by poor heat conductivity during the moulding process. This created temperature gradients throughout the cross section, which resulted in moulded-in stresses. Cycle times of thick walled units were usually exceptionally long. This was another cause of stress, but more than that, longer cycle times meant a reduction in productivity that was crucial for mass production. Furthermore, close tolerances were difficult to maintain, material was wasted, quality degraded, and cost increased.

On the other hand, cross sections that were too thin, were prone to cracking and were likely to form sharp edges that chipped or broke. Sections should not be so thin that melt flowed and welded in their thin edges.

Solid plastic wall thickness for most materials had to be below 5 mm and above 0.5 mm, but preferably around 3 mm in the interest of avoiding these pitfalls. In most cases where injection moulded parts are subjected to heavy loads, geometric structural reinforcement could provide a satisfactory solution; in the others, reinforced material could be considered.

Wall thickness requirements of a part were usually governed by the applied load, the support needed for other components, attachment bosses and other protruding sections. Designing the part to meet all of these requirements while still producing a reasonable uniform wall thickness

was of great benefit [41]. Solid shape modelling was not desired in injection moulding since it lead to longer cooling times and caused sink marks. Therefore the basic rule that applied for part design was: As far as possible the wall thickness had to remain uniform throughout the part [7].

A uniform wall thickness minimized internal stresses, differences in shrinkage, possible void formation and sinks on the surface [41]. It also contributed to material saving and economical production. Most of the features for which heavy sections were intended could be modified by means of ribbing, coring and shaping to provide equivalent strength, rigidity and performance. If a case existed where some transition was unavoidable, the transition had to be gradual to prevent sharp changes in temperature during solidification. Figures 7.1 and 7.2 proposed designs that could be incorporated in a part in order to keep the wall thickness uniform and thick sections to a minimum, without any reduction in the part's functionality.

Walls must be thick and stiff enough to meet the applied loads, though thin enough to cool fast. Parts with varying wall thickness experienced differing cooling rates and different shrinkage. In such cases achieving close tolerance became very difficult and often impossible.

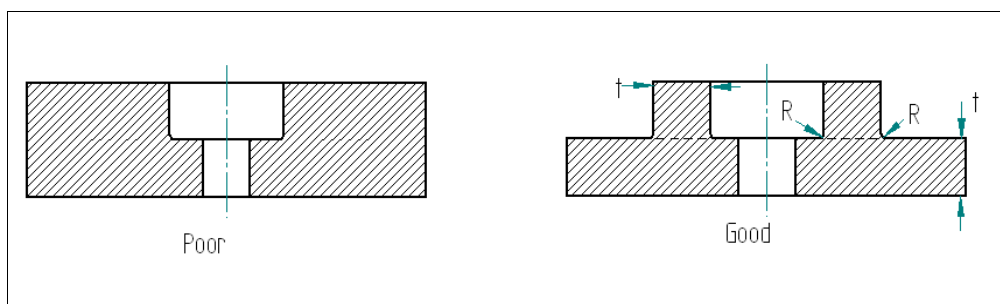

*Figure 7-1: Reducing the wall thickness*

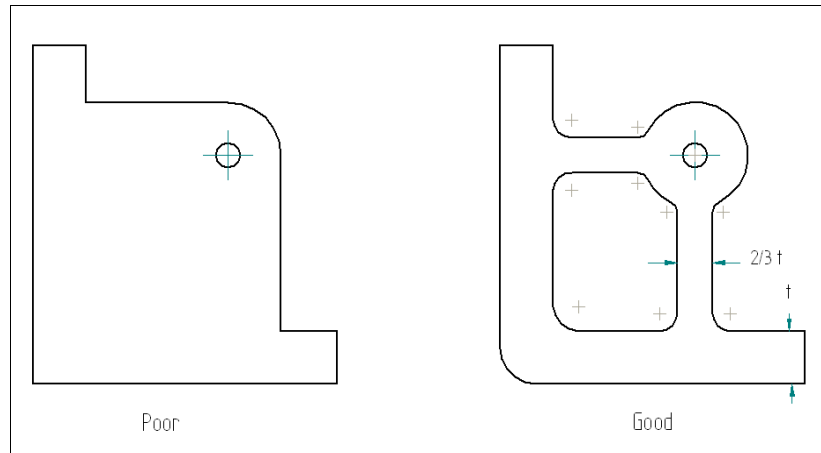

*Figure 7-2: Use ribs to minimize heavy sections and keep wall thickness uniform*

### 7.2.2. SINK MARKS

Thermoplastic melt was highly compressible and can normally be compressed between 10 – 15 % if sufficient pressure was applied [7]. However, the temperature dependant change in volume was as much as 29 %. In other words, the decrease in volume that the melt underwent due to the fall of its temperature in the mould was considerably more than its increase in volume due to the relaxation of pressure. This meant that the void that developed due to material shrinkage could never be filled by the volumetric expansion due to pressure removal. Thus sink marks inevitably formed [7]. Sink marks could be made less apparent by adequate consideration during design.

Parts had to be designed without much variation in wall thickness and without a large mass of melt at any region in the part, if thick areas were necessary lead gradually into them [7].

### 7.2.3. SHARP CORNERS

Sharp corners on the insides of parts were the most frequent property detractors on moulded parts [41]. A sharp corner reduced the impact and

tensile strength of a part significantly [41] [7]. In a shaped part, an inside sharp corner was an indication that the material acted in a brittle manner.

Sharp corners were stress concentrators. The stress concentration factor increased as the ratio of the radius  $R$  to the part thickness  $T$  decreased. An  $R/T$  ratio of 0.6 was favourable, and an increase of this value was of limited benefit. To large a radius was also undesirable, because it wasted material, caused sink marks and even contributed to stresses from having excessive variations in thickness.

The left and right-hand designs in figure 7.3 illustrated the two extremities that lead to poorly designed corners, whilst the centre image indicates optimal design. A round of at least 0.5 mm was desirable on inside corners. In order to maintain the uniformity of the wall thickness, the round on the outside corner had to be equal to the sum of the corresponding inside radius and the wall thickness.

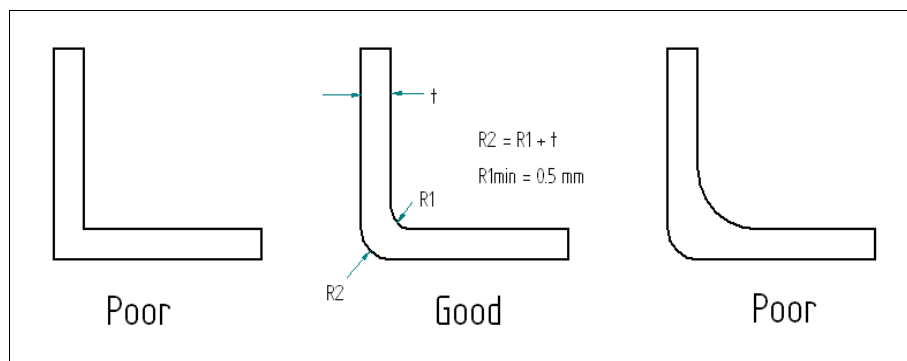

*Figure 7-3: How to design corners*

#### 7.2.4. MOULD FILLING: GATE AND MELT FLOW

Ultimately, part quality could be considered a direct outcome of a plastic melt's flow behaviour in its mould cavity or cavities [41]. Excessive restrictions and obstructions to the flow of material spelt trouble in injection moulding.

The type, location, and size of the gate or gates played an important part during the filling phase in the injection moulding process [7]. The gate had to be located in such a position that the flow path to thickness ratio was close to constant in all directions. It was preferred to have a gate which size did not result in excessive pressure drop; it had to be adequate to handle the required flow rate. Because of the high melt pressure, the area near a gate was highly stressed by both the frictional heat and high velocities of the flowing material [41]. The product designer should be required to caution the tool designer to keep the gate area away from the load-bearing surfaces and to make the gate size such that it improved the quality of the part.

Another role player in the filling phase was the wall thickness variation [7]. Variation in the wall thickness of a part introduced variation in resistance to flow in all directions from the gate. When the melt was injected through the gate and runner system, the melt streams flowed in the direction of least resistance. Ideally, all the melt streams should have move with the same velocity and reached the boundary of the mould at the same time. Variation in cross-sectional area induced variation in melt stream velocity and flow resistance. Hence, the freezing of melt could not be uniform throughout the part. Such unbalanced filling, with some streams that froze faster than others induced ever increasing resistance to flow that continued to disrupt the flow balance and ultimately resulted in the induction of moulded-in stresses [7].

In cases where thickness variation was unavoidable, the design had to allow the melt should flow from the thin to the thick section [41] [7], as showed in figure 7.4. If the flow direction was the other way round hesitation can occur [7]. Hesitation was a phenomenon that presented itself due to a difference in flow resistance. Thick sections presented less



flow resistance than thin sections and thus, if the flow was from thick to thin, flow of the melt stream halted until the thicker section was completely packed before enough pressure was built up to move on into the area that was more difficult to fill.

It was possible to promote the mould filling process even further by designing the parts in such a manner that the melt did not undergo sharp changes in direction [41] [44]. Why more rounded features were preferred to sharply defined edges and corners could be seen from figure 7.5.

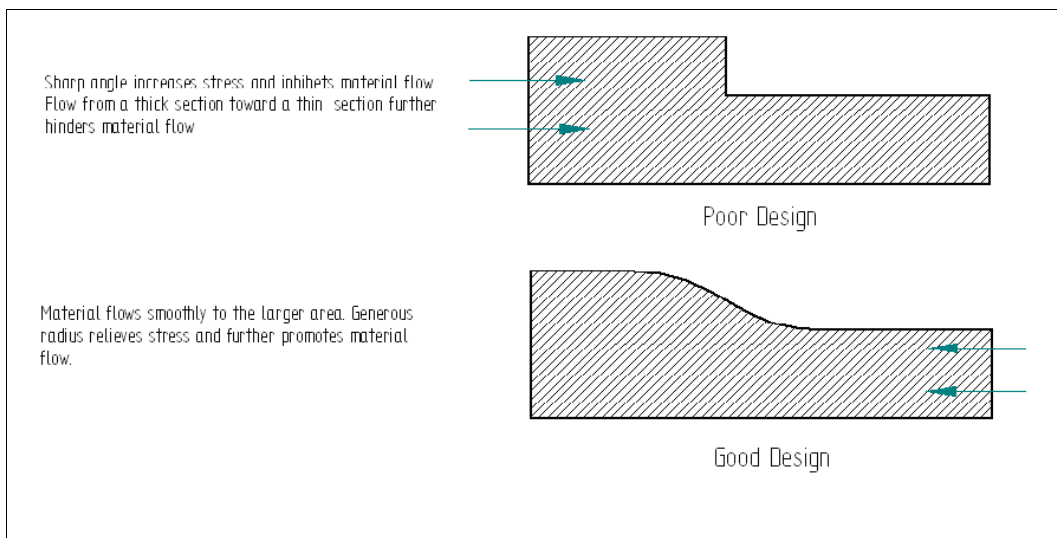

*Figure 7-4: Flow configuration*

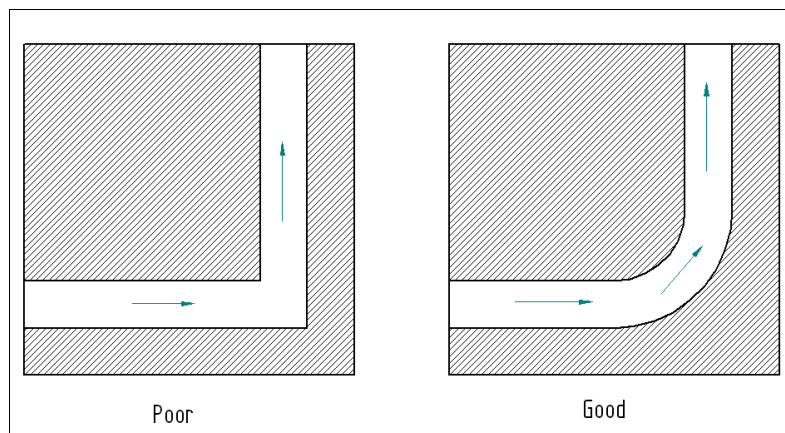

*Figure 7-5: Design to reduce restriction due to change of direction*

#### 7.2.5. WELD AND MELD LINES

During the process of filling the mould cavity, it often happened that the flowing plastic was obstructed by a core. At this point the flowing plastic split its stream and surrounded the core. On the far side of the core the split stream reunited and continued its flow until the cavity was filled. The rejoining of the split stream formed a weld line that lacked the strength properties that existed in an area without a weld line [41] [7]. This lack of material strength occurred because the flowing material to wipe air moisture and lubricant into the area where the joining of the stream took place and introduced foreign substances into the welding surface [41]. Furthermore, since the plastic material had lost some of its heat, the temperature for self-welding could not contribute to the most favourable results. It is preferred not to have a load-bearing surface that contained weld lines. If this is not possible the allowable working stress had to be reduced by at least 15% [41].

A meld line formed in a similar manner as a weld line, except that the flow fronts moved in parallel rather than met head on [41]. The same reduction in physical ability that applied for weld lines, also applied to meld lines.

Figure 7-6 presented a graphic representation of this occurrence. The arrows indicated the flow direction of the melt, whilst the dotted line represented the weld lines.

It was not always possible to eliminate weld and meld lines through smart design, but locations where it occurs could be reinforced or the position could be altered so that they did not impede the design [7].

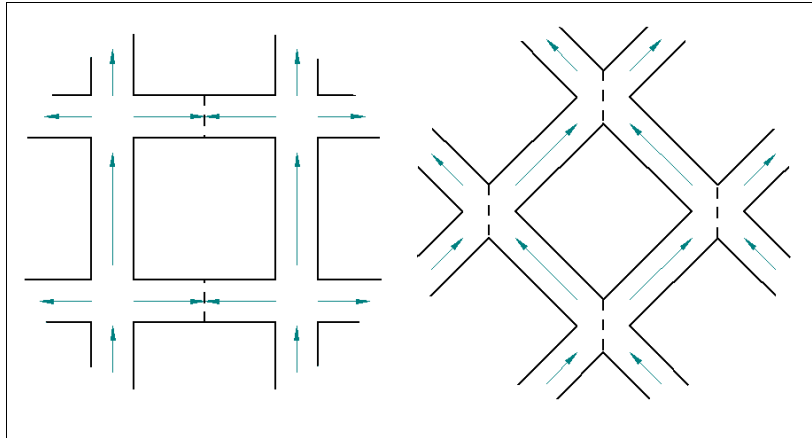

*Figure 7-6: Differing weld lines developed by different flow patterns*

#### 7.2.6. PARTING LINE CONSIDERATION

Parting lines on the surface of a moulded product, which were produced on the surface where the two halves of the mould met, could often be concealed on a thin, inconspicuous edge of the part, as was shown in figure 7.7. Doing so preserved the good appearance of the moulding and in most cases eliminated the need for any finishing [41]. However, this was not the only consideration that dictated the position of the parting line. The parting line had primarily to be chosen to minimize the complexity of the mould by avoiding unnecessary undercuts that required moveable inserts and cores [44]. The parting line had to be straight if at all possible [44]. Thus in order to hide the parting line or simply reduce the cost of flash removal, the parting line constraints had to be considered from the earliest stages of the design phase.

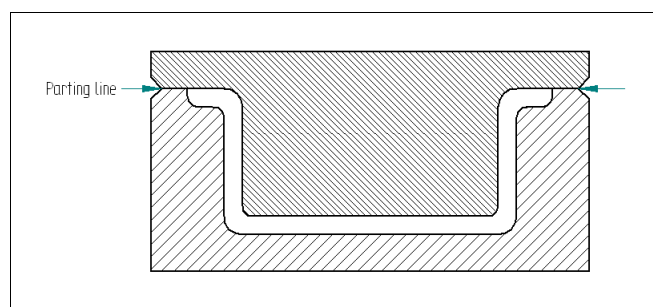

*Figure 7-7: Concealing a parting line*

### 7.2.7. EJECTION PIN MARKS AND GATE MARKS

Ejection pin marks and gate marks had an adverse aesthetic effect on the injection-moulded part. However with adequate consideration in the product design phase, their impact was minimized.

### 7.2.8. TAPER OR DRAFT ANGLE

It was desirable for any vertical wall of a moulded part to have an amount of draft that permitted easy removal from a mould [41] [7]. The direction and magnitude of draft angle that was required, was determined by the location of the parting plane of the mould [44]. The amount of draft that was required varied from  $0.125^\circ$  up to several degrees, depending on what the circumstances permitted. A fair average may be from  $0.5^\circ$  to  $1^\circ$ . When a small angle such as  $0.125^\circ$  was used, the outside surface - the mould surface producing it - required a high directional finish, to facilitate removal from the part. On shallow walls, the use of a much larger draft angle was advised, since the influence of the enumerated drawbacks was minor. One of the difficulties of applying draft to a part was the creation of heavy walls. The potential problem of removal was often remedied by using parallel drafts where the walls are kept uniform. Figure 7.8 provided an example of such parallel drafted surfaces.

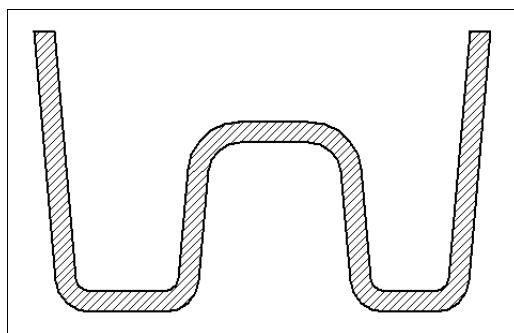

*Figure 7-8: Parallel draft surfaces can keep wall thickness uniform*

### 7.2.9. GEOMETRIC STRUCTURAL REINFORCEMENT

If there was sufficient space, the use of ribs for geometrical structural reinforcement was normally a practical and economical means of increasing the structural integrity of plastic parts without thickening the part's walls. Although the use of ribs gave the designer great latitude in efficiently tailoring the structural response of the plastic part, the ribbing sometimes resulted in warping and appearance problems. In general, experienced design engineers did not use ribs if there was doubt as to whether the use of it was essential. Adding ribs after a tool was built was usually simple and relatively inexpensive since it only involved removal of material.

There were certain basic rib design guidelines that had to be followed. The most common was to make the rib thickness at its base equal to one half the adjacent wall's thickness. With ribs opposite appearance, the width was to be kept as thin as possible. In areas where structure was more important than appearance or with very low-shrinkage materials, the ribs' thickness was often 75 or even 100% of the wall's thickness. The goal in rib design was to prevent the formation of a heavy mass of material that could result in a sink, void, distortion, long cycle times, or any combination of these problems. All ribs had to have a minimum of  $0.5^\circ$  draft per side and minimum radius of 0.125 mm at the base. Generally the draft and thickness requirements limited the height of the rib. Figure 7.9 depicted a rib that followed these afore described constraints.

Multiple, evenly spaced ribs was preferred to large single ribs. Whenever possible, ribs had to be smoothly connected to other structural features such as bosses, sidewalls and component mounting pads. It was not a requirement that ribs need to be constant in height or width and it was possible to match the ribs to the stress distributions in the part.

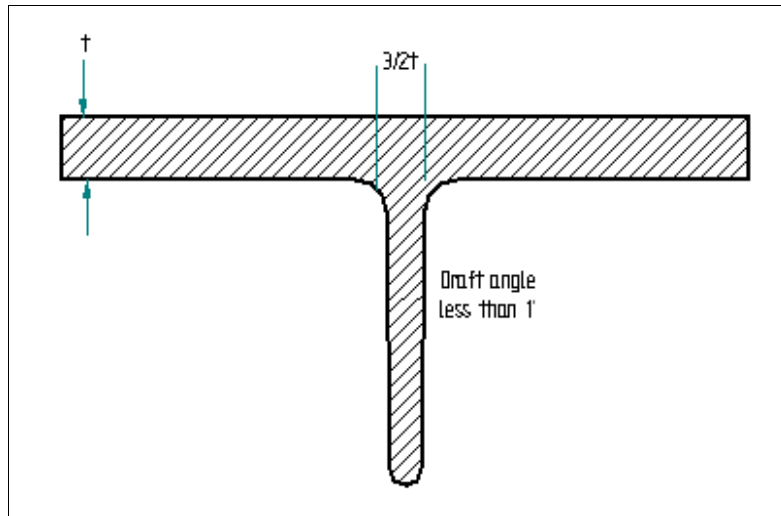

*Figure 7-9: A basic guideline for rib design*

Besides ribs, there were other methods of improving sectional properties some of which could be seen in Figure 7.10. Many of these could often be designed into functional or appearance features of the product. Some geometric shapes that provided the designer with means of increasing part supports included gussets, corrugating, doming and ribbing. Gussets were supporting structures for either the edge of a part or bosses. The design guidelines for gusset thickness, spacing and taper were similar to those described for ribs. Corrugating and doming provided the designer increased part performance without having to add ribs. Of these two methods corrugating was more effective. Doming on the other hand was often preferred to corrugating for aesthetic purposes. The following figure showed a few examples of geometric structural reinforcement techniques.

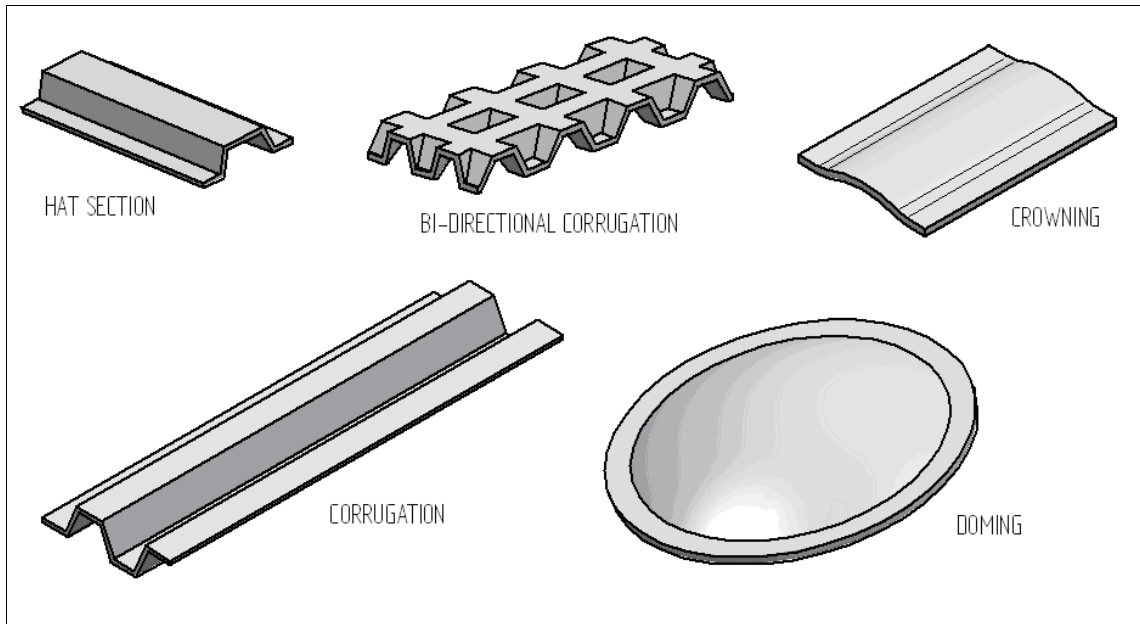

*Figure 7-10: Examples of geometric structural reinforcement*

#### 7.2.10. UNDERCUTS

Undercuts, whether internal or external, had to be avoided as far as possible [41]. It was often possible to encapsulate the desired design intent without undercutting mould movement; however, in order to conceive such a design, designers had to give this aspect ample consideration right from the beginning of the design process. Figure 7.11 showed a few examples of how undercuts could be avoided without sacrificing the design intent.

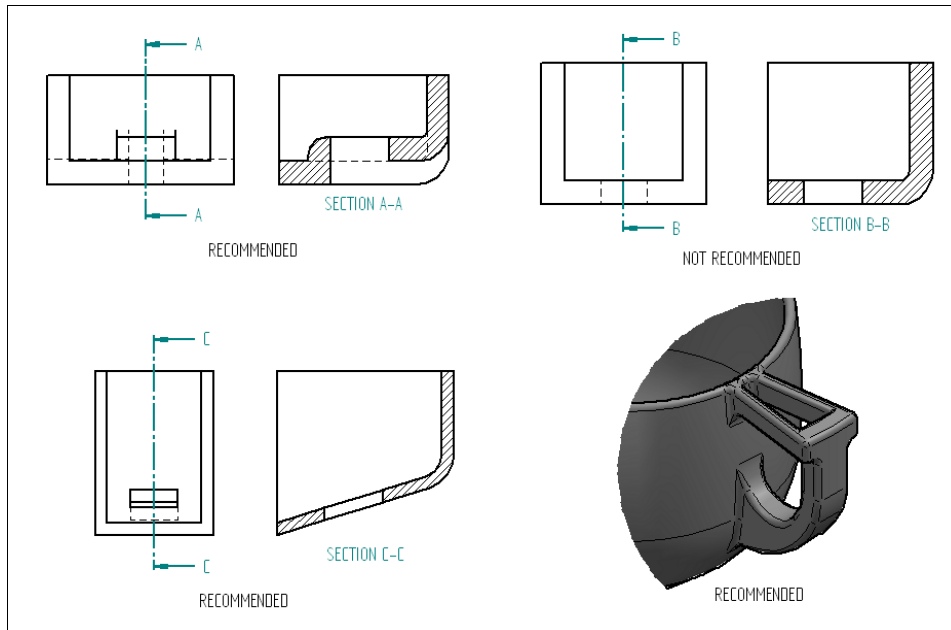

*Figure 7-11: Sidestepping undercuts*

In cases where it was essential to incorporate undercuts in the part design, a great many were often realized by appropriate mould design in which either sliding components on tapered surfaces or split cavity cam actions produced the needed undercut. This obviously went hand in hand with increased tool cost, normally in the neighbourhood of 15 to 30% [41].

Some conditions however permitted incorporating undercuts with conventional stripping of the part from the mould [41]. Certain precautions were necessary in order to attain satisfactory results [41]. Firstly the protruding depth of the undercut had to be two-thirds of the wall thickness or less. Secondly, the edge of the mould against which the part was ejected had to be radiused to prevent shearing action. Finally the part being removed had to be hot enough to permit easy stretching and return to its original shape after removal from the mould.

#### 7.2.11. CORING

The term coring in injection moulding referred to the addition of steel to the mould for the purpose of elimination plastic material in that area [41].



Usually, coring was necessary to create a pocket or opening in the part or simply for the purpose of reducing an overly heavy section. For simplicity and economy in injection moulds, cores had to be parallel to the line of draw in the mould [41]. Cores placed in any other direction usually create the need for some type of side action (either a cam or hydraulic cylinder) or manually loaded and unloaded loose cores.

In injection moulded plastic parts, a core supported by only one side of the mould created blind holes. The length of the core and depth of the hole was limited by the ability of the core to withstand the bending forces produced by the flowing plastic without excessive deflection [41]. In some instances, if even longer cores were necessary, the tool could be designed to balance the hydraulic pressure on the core pin, thus limiting the deflection [41].

#### 7.2.12. BLIND HOLES

It was important to ensure that sufficient material surrounded the holes and that the melt could flow properly around them. A core pin that formed a hole was subjected to the bending forces that existed in the cavity due to the high melt pressures. Calculations could be made for each case by establishing the core pin diameter, its length and the anticipated pressure conditions in the cavity. Technical handbooks indicated that a pin supported on one end only, deflected 48 times as much as one supported on both ends. This suggested that the dimensional accuracy of through holes was so much better than that of blind holes that it had to be the preferred design.

If a through hole could not provide a practical solution and a blind hole had to be used, the depth of hole in relation to the diameter had to be small, in order to maintain accuracy. In general, the depth of a blind hole should not have exceeded three times its diameter or minimum cross-sectional dimension [41]. It is recommended that for small blind holes

with a minimum dimension below 5 mm the L/D ratio had to be kept to 2 [41]. Figure 7.12 gave a general guideline for the design of blind holes

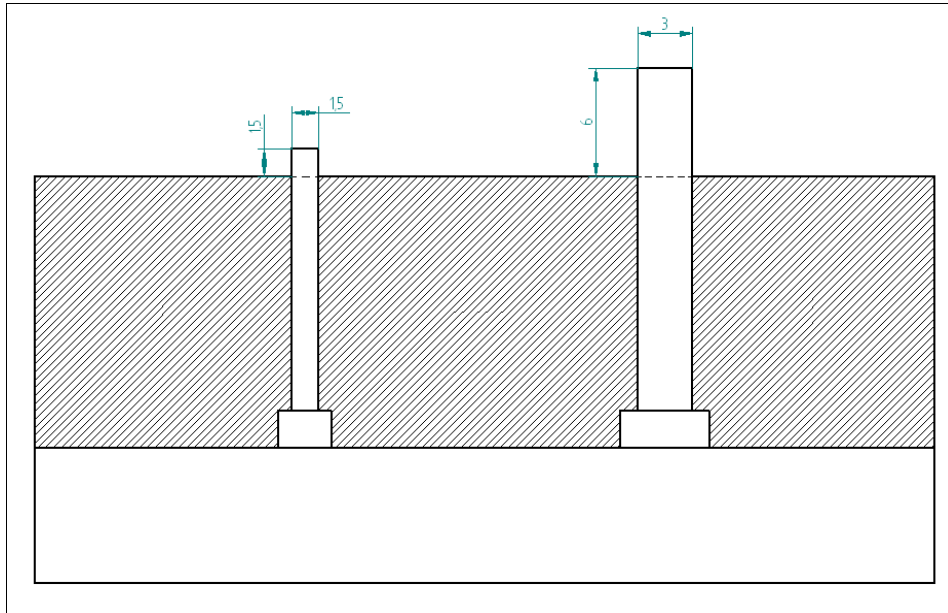

*Figure 7-12: Basic guide for blind-hole design*

### 7.2.13. HOLES

If a hole was too near to an edge or corner, material often did not weld properly around the pin [41]. Also the one-sided flow of the melt could bend the core pins for blind holes when their length exceeds 2.5 times their diameter. Similar bending of the core pin could occur when long through holes with small diameters were moulded, even though both ends of the core pin were anchored.

Whenever it was possible, chamfering had to be used on open holes, since it reduced or eliminated the potential for rough moulded corners, cracks, and the like [41].

Holes that were impractical to mould had to be drilled, but should not be too close to edges or corners, as cracks often resulted [41]. It was difficult to drill a small diameter hole along its intended direction to any

great depth, thus the most practical approach in many products was to mould the hole part of the way and then drill the remainder of the distance.

Generally speaking, the accuracy of through holes was better than blind holes since the core of a through hole was supported on both sides of the mould cavity. With through holes the overall length of a given core size could normally be twice as long as that of a blind hole.

#### 7.2.14. SELF-TAPPING SCREWS

Self-tapping screws were an economical means of securing separable plastic joints [41]. The screws could be either thread-cutting or thread-forming. Thread-cutting screws were preferred unless repeated disassembly was necessary [2]. The self-tapping screws were driven into the moulded part, eliminating the need for a moulded-in thread or secondary tapping operation. Screws or threaded bolts with nuts required through-going holes but provided an easy assembly system. It was recommended that these screws had to be used in conjunction with washers in order to have the load distributed on a larger surface area [41]. For the highest ratio of stripping to driving torque, a hole with diameter equal to the pitch diameter of the screw had to be used. Where self-tapping screws were used, the most practical boss outer diameter was 2.5 times the external screw diameter [2]. Too thin a boss could have cracked, and no acceptable increase in stripping torque was achieved with thicker bosses. Stripping torque increased with increasing length of engagement and levelled off when the engaged length was about 2.5 times the pitch diameter of the screw [2].

#### 7.2.15. PLASTIC THREADS

External and internal screw threads could be moulded in plastic parts. Threads produced by the mould itself using rotating cores, split inserts, or

collapsible cores was often a more economical option than postmoulding threading operations.

To design a screwed joint all sharp interior corners had to be eliminated. The beginning as well as the end of the thread had to be rounded off in order to avoid notch effects [2]. Coarse threads could be moulded easier than fine ones, so threads with a pitch smaller than 0.8 mm had to be avoided. Generally the length of the thread used had to be at least 1.5 times the diameter and the section thickness around the hole more than 0.6 times the diameter. Feathered edges had to be avoided and tightening with the bolt shoulder limited [41]. Simple designs had to be used when permitted, such as wide-pitch threads. The thread had to be designed to start about 0.8 mm from the end of the face perpendicular to the axis of the thread. The strength of plastic threads was limited and when moulded in a part involving either an unscrewing device or a rounded shape of thread, similar to bottle-cap threads, that could be stripped from the core [41].

External threads could be moulded by either splitting the mould in halves or by running a parting line across the thread if it was permitted [41]. With a split mould, it was basically easier to design the mould and remove the treaded part from the mould during processing. The design of threads required control to prevent excessive shear, that resulted in stripping of the threads when torqued and also to limit the hoop stresses which could result in tensile failure. When male plastic threads are considered, the coarser threads are again preferred with a thread root that was rounded to prevent the notch effect [41]. Engineering plastics generally had better resistance to compressive stresses than to tensile stresses and therefore threads that were to be coupled with metal components had to be made on the outside of the plastic part [41] [2].

#### 7.2.16. PRESS FITS

Press fits, which depended on having a mechanical interface, provided a fast, clean economical assembly [41]. Press fits could be used with similar or dissimilar materials and if applied correctly, eliminated screws, metal inserts, adhesives, etc. [2]. A common use was to have a plastic hub or boss that accepted either a plastic or metal shaft or pin. The press fit tended to expand the hub, creating tensile and hoop stresses. If the interference is too great, high strain and stress developed. The designer had to check that the maximum developed stress was below the value that produced creep rupture in the material, as there usually was a weld line in the hub that significantly affected the creep rupture strength of most plastics [41]. An additional frequent complication with press fits was that the round hub or boss was often difficult to mould if strict processing controls are not used to eliminate potential problems. Except for light press fits, this type of assembly was risky [41]. For press fits that were designed to carry a heavier load it was recommended to reinforce the plastic by means of metal hoop rings or the like. When designing an interference press fit the addition of crush ribs to the inside diameter of the boss was recommended.

#### 7.2.17. BOSSES

Bosses and other projection from the nominal wall were commonly found in injection moulded plastic parts. These often served for mounting or fastening points. Bosses that were designed to accommodate self-tapping screws had to have sufficient wall thickness to withstand the hoop stresses that developed due to thread forming [41] [7]. The inside diameter of the boss could be manipulated in such a way that the build up of excessive hoop stresses was be avoided [41]. Furthermore, the bore of the boss had to be deeper than the depth to which the thread was cut. Care had to be taken to avoid moulded-in stresses in a boss, as it could cause failure in this aggressive environment. Strong weld joints around screw bosses were essential. The bore at the entrance of the boss had to have a short length

with a slightly larger diameter [7]. This helped to locate screws before insertion.

When lateral forces were expected, ribs could be used in conjunction with the bosses. Figures 7.13 and 7.14 gave some general guidelines for some typical boss designs. As with all rib design, overly thick wall sections had to be avoided as it was important to minimize the chance of appearance or moulding problems [41].

Special care had to be used when tapered pipe threads were moulded, since it could create a wedging action on the boss. If there was a choice, the male rather than the female pipe thread had to be the one moulded into the plastic [41].

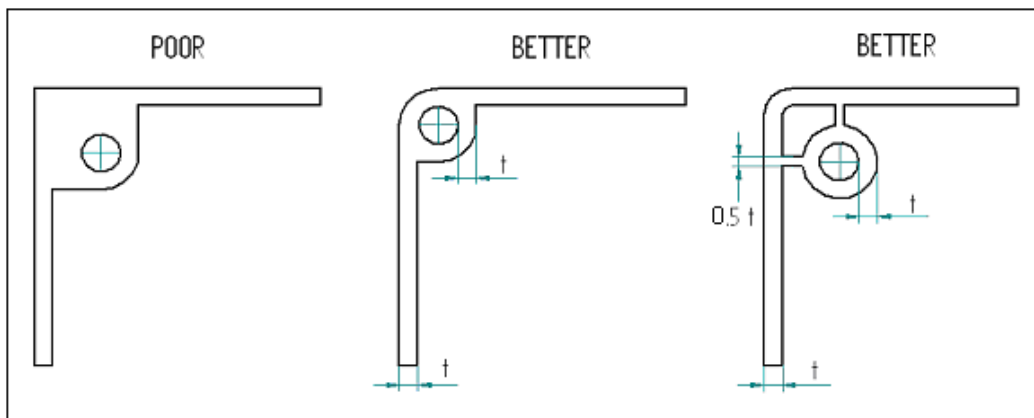

*Figure 7-13: Design guide for bosses*

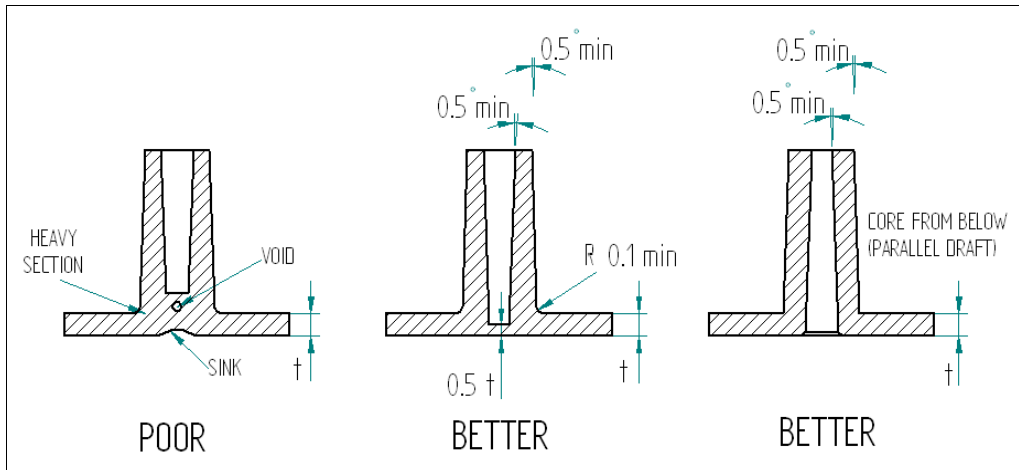

Figure 7-14: Design guide for bosses

### 7.2.18. SNAP-FITS

A snap joint was economical in two respects: It allowed the structural member to be moulded simultaneously with the moulded part, and it allowed rationalizing the assembly, compared with such other joining processes as screws [41]. The most common types of snap fits were illustrated in figure 7.15 [2]. Figure 7.15 A was an example of a snap fit with spherical undercut, 7.15 B, a snap-fit with cylindrical undercut and mating lip, and 7-15 C a snap-fit with flexible cantilevered lugs.

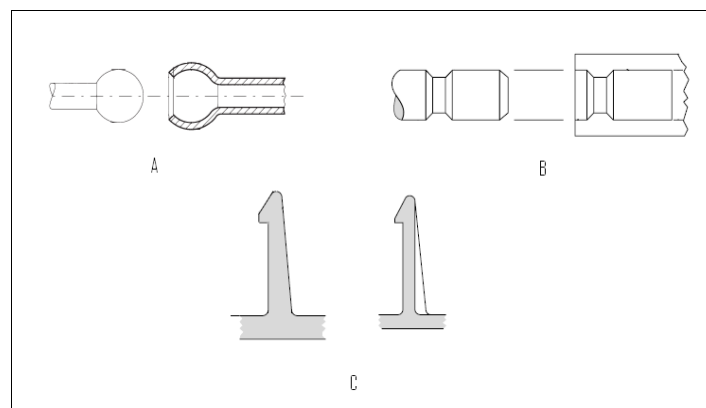

Figure 7-15: Common snap-fits: A, a snap-fit with spherical undercut. B, a snap-fit with cylindrical undercut and mating lip and C, a snap-fit with flexible cantilevered lugs

Although figure 7.15 made a distinction between a spherical and cylindrical snap-fit, the principles that governed the design and function of these types of snap-fits are essentially the same. Accordingly, spherical snap-fits could be seen as a special kind of cylindrical snap-fit [2].

Cylindrical snap fits were generally stronger but require greater assembly force than cantilevered lugs. The undercut part of cylindrical snap-fits was usually ejected by snapping them off the core. This required a certain amount of deformation; accordingly materials with good recovery characteristics were required [2].

In order to obtain satisfactory results, the spherical and cylindrical type of the snap-fit design had to fulfil certain requirements [2]: It was essential to keep the wall thickness constant throughout. There had to be no stress risers. The snap fit had to be placed in an area where the undercut section could expand freely. As far as the shape of this type of snap-fit was concerned, it ideally should have been circular. The more the shape deviated from circular the more difficult it should to eject and assemble the part.

It sometimes happened that a cylindrical or spherical snap-fit cracked during assembly due to weak spots produced by weld lines, gate marks or voids. If a weld line was the problem and could not be avoided by changing the overall design or by moving the gate to another location, the section at the weld line could be strengthened by means of a bead or rib [2].

The second category into which snap-fits could be classified was based on cantilevered lugs, the retaining force of which was essentially a function of bending stiffness. These were actually special spring applications that were subjected to high bending stresses during assembly [2].



Under working conditions the lugs were either completely unloaded for moving parts or partially loaded to achieve a tight assembly. The typical characteristic of these lugs was an undercut of 90° that was always moulded by means of side cores or corresponding slots in the parts.

Cantilevered lugs had to be designed in a way so as not to exceed allowable stress during assembly operation [2]. Too short a bending length often caused breakage. The example in figure 7.16 showed how this can be done. The design in figure 7.16 B had flexible lugs that are considerably longer than the design illustrated in figure 7.18 A; accordingly the stresses was much lower in figure 7.16 B than the poorly designed alternative.

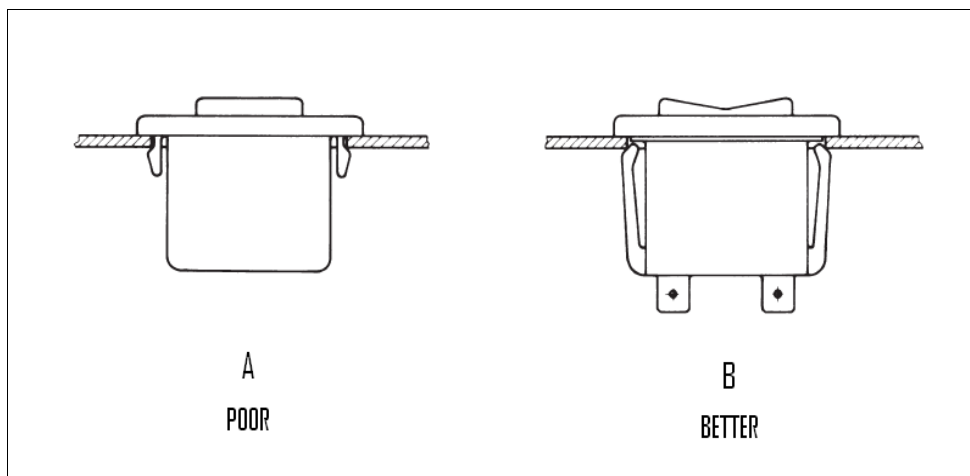

*Figure 7-16: Designing cantilevered lugs*

Cantilevered lugs had to be dimensioned to develop constant stress distribution over their length. This was achieved by providing a slightly tapered section or by adding a rib, as illustrated in figure 7.16 C. Special care had to be taken to avoid sharp corners and other possible stress concentrations, which could cause failure during assembly [2].

When a fracture of the snap-fit occurred as a result of overloading during the joining operation, the problem can be remedied not by increasing the cross section; instead the hook should be designed to be more flexible [41].

The arrangement of the undercut should always have been chosen in such a manner that the deformations of the moulded part from shrinkage distortion unilateral heating and loading did not disturb its functioning [41] and on account of the frictional forces and stresses that appeared at the point of joining, all angles of joining should have been chosen to be no larger than  $60^\circ$  [41].

#### 7.2.19. INTERNAL HINGES

Hinge designs for lids, boxes, caps and many other products had long been well established. Figure 7.17 illustrated the relationships between the dimensions that were crucial to the design of a living hinge. The thickness of the hinge,  $t$  in figure 7.17, had to be approximately equal to the sidewalls of the part [41]. Due to the mould fill requirements and the necessary stiffness of the hinge action, the thickness of the web,  $b$ , should have been around half the thickness of  $t$ , but it was not recommended that it be less than 0.125 mm [53] [41]. The length of the web to thickness ratio should have been no less than 3 to 1 [41].

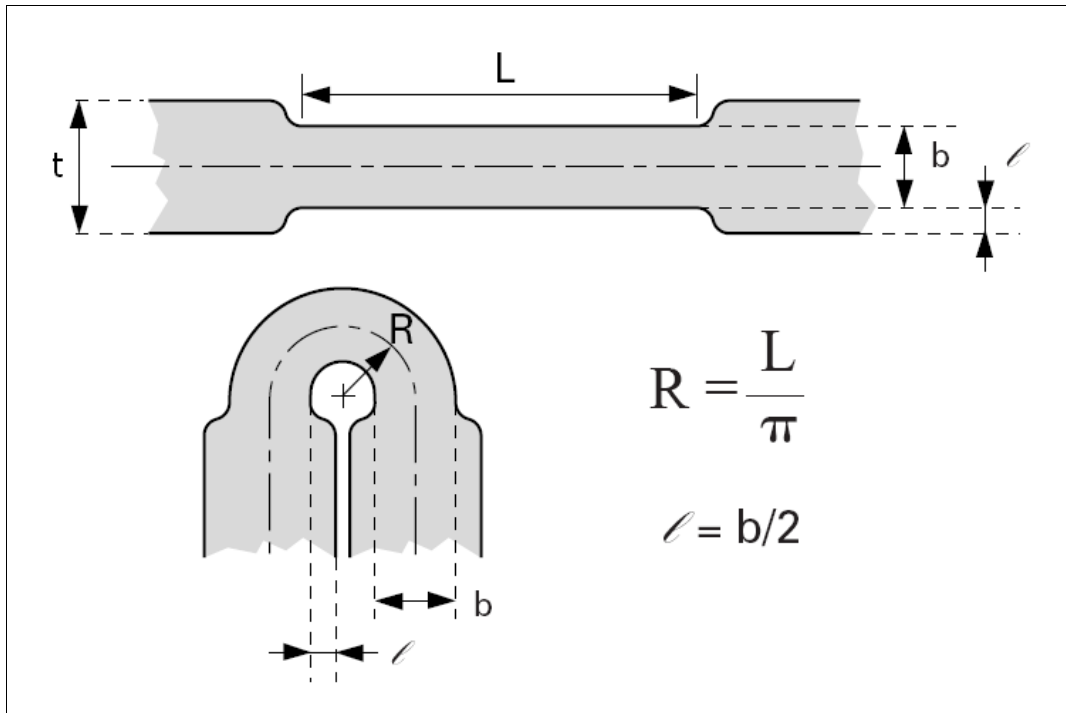

*Figure 7-17: Living hinge design*

The functionality of living hinges depended not only on the design shape, but also on the direction of the melt flow through the hinge [41]. It was vital to ensure that the melt flow during the moulding operation was perpendicular through the hinge (perpendicular to the hinge's bending action) so that its molecules stretched to give a strong, pliable hinging section. It was also important to locate gates in the proper position in relation ship to the thickness and flow pattern of the melt so that the melt flowed properly through the hinge [41]. An example of a poor flow condition was to have gates on opposite sides of a hinge, so that a weld line formed within the hinge, causing it to fail upon first being bent.

There were literally thousands of successful living hinge applications. One such a design was illustrated in figure 7.18 [41].

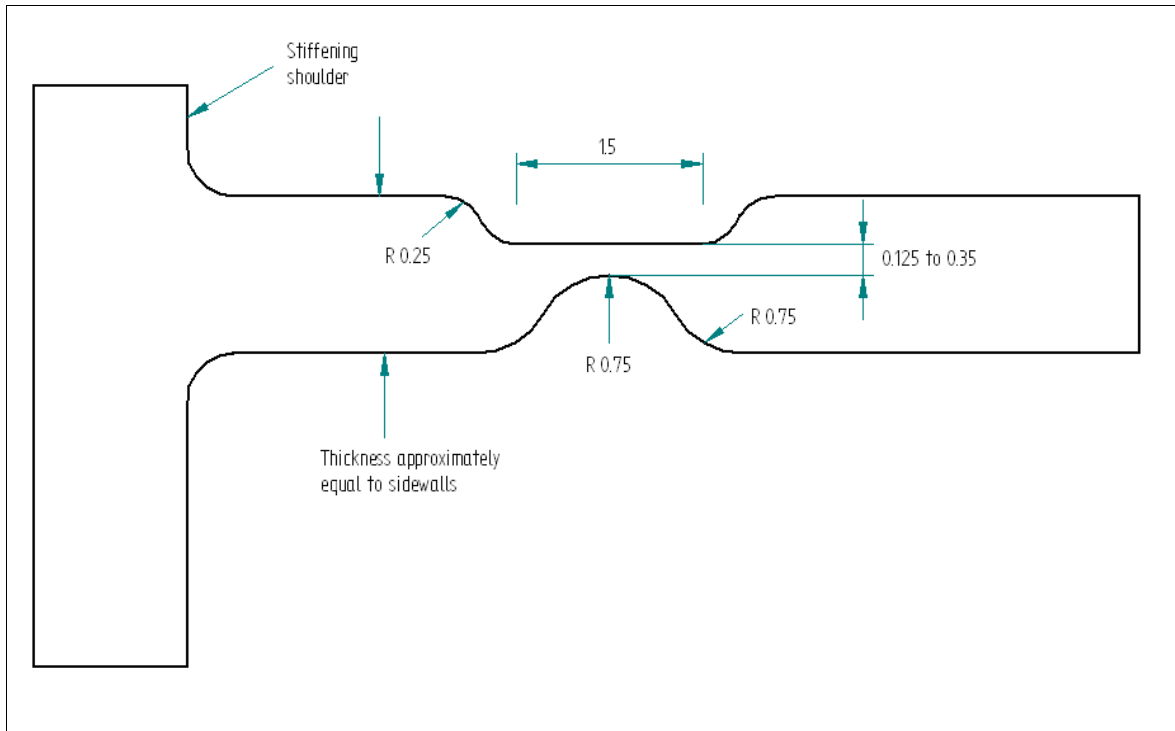

*Figure 7-18: A successful living hinge design*

### 7.3. SUMMARY OF INJECTION MOULDING DFM GUIDELINES

Table 7.1 gives a comprehensive summary of design for injection moulding guidelines.

Table 7-1: Guiding principles when designing for injection moulding

<b>Designing for injection moulding guidelines</b>	
Wall thickness constraints	Wall thickness had to be below 5mm and above 0.5mm, but preferably around 3 mm to avoid a lessening of mechanical properties due to heavy walls or defects associated with too thin walls.
	If possible wall thickness had to be kept uniform throughout the part [7] [41].
	If non-uniform wall thickness was unavoidable, transitions had to be gradual to prevent sharp changes in temperature during solidification.
Considering sink marks	Sink marks could be made less apparent by designing parts with constant wall thickness and without large masses of melt at any region in the part.
	If thick areas were necessary, lead gradually into them [7].
The effect of sharp corners	Sharp corners reduced the impact and tensile strength of a part and should be avoided [41] [7].
	Stress concentration factor increased as the ratio of the radius to the wall thickness decreased, an R/T ratio of 0.6 was favourable.
	Limited advantage was gained if $R/T > 0.6$ as it did not contribute significantly to part strength and caused sink marks.
Mould filling considerations	Excessive restrictions and obstructions to the flow of material had to be avoided.

*Table 7.1: Guiding principles when designing for injection moulding  
(Continued)*

<b>Designing for injection moulding guidelines</b>	
Weld lines	Weld lines that formed on the far side of a core where the split melt stream reunited, lacked the strength properties that existed in areas without weld lines, consequently the allowable working stress of these areas had to be reduced by 15% [41] and an effort had to be made not to load such areas at all.
Ejection pin and gate marks	Ejection pin and gate marks could have a negative effect on part aesthetics and had to be considered early during design
Parting line considerations	The parting line had to be chosen to minimize the complexity of the mould by avoiding unnecessary undercuts [44].
	Whenever possible the parting line had to be concealed on a thin, inconspicuous edge [41].
Taper or draft angle	It was desirable for any vertical wall of a moulded part to have an amount of draft that permitted easy removal from a mould [41] [7].
Geometric structural reinforcement	Geometrical structural reinforcement, such as doming, corrugating or ribbing was a practical and economical means of increasing the structural integrity of plastic parts without thickening the walls.
Ribbing	Rib thickness at its base had to be equal to half the adjacent wall's thickness.
	All ribs had to have had a minimum of $0.5^\circ$ draft per side and minimum radius of 0.125 mm at the base.
	Multiple, evenly spaced ribs were preferred to large single ribs.

*Table 7.1: Guiding principles when designing for injection moulding  
(Continued)*

<b>Designing for injection moulding guidelines</b>	
Undercuts	Undercuts, whether internal or external, had to be avoided as far as possible [41].
	It was often possible to encapsulate the desired design intent without undercutting mould movement; however, in order to conceive such designs, designers had to give early consideration to this aspect.
Holes and blind holes	The length of the core and depth of the hole was limited by the ability of the core to withstand the bending forces produced by the flowing plastic without excessive deflection [41]
	For small blind holes with a minimum dimension below 5 mm the length to diameter ratio had to be kept below 2 [41].
	Holes had to be located far enough from edges and corners to permit material to weld properly around the pin [41]
	Whenever it was possible, chamfering should be used on open holes, since it reduced or eliminated the potential for rough moulded corners and cracks [41].
	Holes that were impractical to mould had to be drilled, but they were not to be too close to edges or corners, as cracks can result [41].
	Accuracy of through holes was generally better than that of blind holes.
Self tapping screws	Self-threading screws could be an economical means of securing separable plastic joints and should be kept in consideration [41].

*Table 7.1: Guiding principles when designing for injection moulding  
(Continued)*

<b>Designing for injection moulding guidelines</b>	
Press fits	Check that the maximum developed stress was below the value that produced creep rapture in the material as there was usually a weld line in the hub that significantly affected the creep rapture strength of most plastics [41].
	When designing an interference press fit the addition of crush ribs to the inside diameter of the boss was recommended.
Cylindrical and spherical snap fits	It was essential to keep the wall thickness constant throughout.
	There had to be no stress risers.
	The snap fit had to be placed in an area where the undercut section could expand freely.
	The ideal shape for this type of snap-fit was circular.
	Cracks developed during assembly due to weak spots produced by weld lines, gate marks or voids. If a weld line was the problem and cannot be avoided by changing the overall design or by moving the gate to another location, the section at the weld line could be strengthened by means of a bead or rib [2].
Bosses	The bore of the boss had to be deeper than the depth to which the thread will be cut [7].
	The bore at the entrance of the boss had to have a short length with a slightly larger diameter [7].
	Strong weld joints around screw bosses were essential [7].



*Table 7.1: Guiding principles when designing for injection moulding  
(Continued)*

<b>Designing for injection moulding guidelines</b>	
Plastic thread	External and internal screw threads could be moulded in plastic parts.
	All sharp interior corners had to be eliminated [2].
	The beginning as well as the end of the thread had to be rounded off in order to avoid notch effects [2].
	Coarse threads could be moulded easier than fine ones, thus threads with a pitch smaller than 0.8 mm had to be avoided [41]
	The length of the thread used had to be at least 1.5 times the diameter and the section thickness around the hole more than 0.6 times the diameter [41].
	The thread had to be designed to start about 0.8 mm from the end of the face perpendicular to the axis of the thread [41].
	As engineering plastics generally had better resistance to compressive stresses than to tensile stresses, threads that were to be coupled with metal components had to be made on the outside of the plastic part [41] [2].

*Table 7.1: Guiding principles when designing for injection moulding  
(Continued)*

<b>Designing for injection moulding guidelines</b>	
Snap fits with cantilevered lugs	Cantilevered lugs had to be designed so as not to exceed allowable stress during assembly operation [2].
	Too short a bending length could cause breakage.
	Cantilevered lugs had to be dimensioned to develop constant stress distribution over their length. This could be achieved by providing a slightly tapered section or by adding a rib.
	Special care had to be taken to avoid sharp corners and other possible stress concentrations.
	To remedy a fracture of a snap-fit that occurred as a result of overloading during the joining operation, the cross section should not be increased, but the hook should be designed to be more flexible [41].
	On account of the frictional forces and stresses that appeared at the point of joining, all angles of joining should be chosen to be no larger than 60° [41].

*Table 7.1: Guiding principles when designing for injection moulding  
(Continued)*

<b>Designing for injection moulding guidelines</b>	
Internal hinges	The hinge should be designed so that the thickness had to be approximately equal to the sidewalls of the part [41].
	Due to the mould fill requirements and the necessary stiffness of the hinge action, the thickness of the web should have been around half the wall thickness but it was not recommended that be less than 0.125 mm [53] [41].
	The length of the web to thickness ratio of the web should be designed to be no less than 3 to 1 [41].
	It was vital to ensure that the melt flow during the moulding operation was perpendicular through the hinge (perpendicular to the hinge's bending action) so that its molecules stretched to give a strong, pliable hinging section.

#### **7.4. CHAPTER SUMMARY**

The details of design for injection moulding were presented in the preceding chapter. These guidelines were divided into the following categories:

- Guidelines aimed to prevent part failure due to material strength considerations. These guidelines included suggestions on the design of screw threads and considerations when designing sharp corners, geometric structural reinforcement, press fits, snap-fits and living hinges.
- Guidelines aimed to promote better mould filling. Amongst others these guidelines included elements such as gating, melt

flow, thick thin sections, wall thickness constraints and weld lines.

- Guidelines that were implemented to circumvent inherent process limitations and issues that invariably resulted in low quality designs, these included recommendations to reduce sink marks, parting line considerations, suggestions about ejection pin and gate marks etc.

## CHAPTER VIII

### 8. DESCRIPTION OF THE REPRESENTATIVE SFF MANUFACTURING PROCESS

#### 8.1. CHAPTER OBJECTIVES

In this chapter a description of the representative SFF process was provided. This detailed description provided insight into the fundamental operation of the process that reinforced the inherent limitations and opportunities of the process that were identified in chapters 3 and 4. Furthermore this thorough understanding of the manufacturing process made it possible incorporate the LS process into the product development process in the same manner that an understanding of the injection moulding process made such a theoretical integration possible in the previous chapter.

In short this chapter's objectives were:

- To present a detailed account of the laser sintering process.
- To reinforce statements regarding inherent strengths and weaknesses of the LS process.

#### 8.2. LASER SINTERING

Selective laser sintering was a SFF process that was developed by Dr. Carl Deckard at the University of Texas [49] [46]. It was patented in 1989 and licensed to DTM Corporation of Austin Texas. In 2001 3D systems, Inc. acquired DTM Corporation and at the time of writing sold SLS systems. A German company by the name of Electro Optical Systems or EOS, had developed a similar system called Laser Sintering (LS) [49]. The two processes were essentially the same [35].

Laser Sintering was a layer-by-layer manufacturing technique that generated solid three-dimensional parts by the selective sintering of powder with heat provided by a CO<sub>2</sub> laser. The process was based on the theory of ordinary sintering processes such as metal and ceramic sintering and theoretically any sinterable material powder could be used for production.

To date, laser sintering had largely been used for the manufacture of prototypes. Laser sintering was especially suitable for the manufacture of functional prototypes since it offered the key advantage of making parts in essentially final materials [15]; however it was also used for a number of other applications such as form and fit analysis, field testing and aesthetic models [47].

There was a growing tendency to use laser sintering for rapid manufacturing (RM). These RM laser sinter products were used for an even wider range of applications than injection moulded parts. Prosthetic devices, special medical diagnostic equipment and products for the military were high rankers amongst the uses of RM LS products. There were even a few LS products to be found on board of the International Space Station [60].

### *8.3. PROCESS DESCRIPTION OF LASER SINTERING*

The process could be described as follows: A CAD model of the part that was to be produced is exported as a STL file. By making use of applicable software, this .STL file was verified to detect and fix problems and orientated and positioned within the build envelope. After orientation and fixing, this .STL model was scaled to compensate for shrinkage and then sliced into layers perpendicular to the z-axis of the growth orientation. These sliced profiles were the profiles that the laser “drew” on the powder

and “stuck” on top of one another in order to create the desired shape. This data file was then fed to the LS machine.

Before the actual building process commenced the whole building envelope was heated to a temperature just below the melting point of the plastic powder so that heat from the laser needed only to elevate the temperature slightly to cause sintering. This greatly sped up the process. In order to prevent oxidisation and eliminate the possibility of dust explosions, all oxygen was removed from the building envelope and in turn filled with nitrogen [36].

The mechanism of the SLS process was illustrated in figure 7.1 [15]. Within the preheated build envelope a measured amount thermoplastic powder was delivered by a powder delivery system and spread evenly over the surface of a build cylinder by a roller or a powder through. LS worked on a similar principle but the powder delivery system differed somewhat. Instead of a roller and a piston-like powder delivery system, a device called a re-coater handled powder delivery in LS. Contrarily to the roller, the re-coater deposits powder and scraped it even with a blade as it crossed the building platform. Before the fresh layer of powder was deposited, the fabrication piston in the cylinder moved down one object layer thickness to accommodate the new layer of powder. Simultaneously the powder delivery system of a SLS machine moved one layer thickness upwards. In a LS system the re-coater remained stationary.

One layer thickness was typically between 0.1 mm and 0.15 mm thick. The layer thickness stood in direct relation to the build time and surface finish of the parts. A system with very fine layer thickness had long build times but produced parts that had a smooth surface finish. Likewise a system with larger layer thickness decreased build time but at the same time decreased the quality of the surface finish.

After completion of the material deposition step, the CO<sub>2</sub> laser scanned across the powder bed, elevating the temperature of the material where it passed. This increased temperature, although not sufficient to melt the material completely, caused the particles to bond at their contact points and solidify into a new layer of the part. The depth to which the powder solidified is a function of the laser power and material sintering temperature [48]. In order to solidify only a single layer of powder, the scanning speed of the laser was controlled, so that it imparted only the necessary amount of energy to the material.

When the laser finished its sintering of a layer, the roller or re-coater applied another layer of powder, the fabrication piston and the supply piston again moved down and up respectively and the laser traced the next profile on the powder, thereby forming the subsequent layer and unifying it with all preceding ones. The process was then repeated until the entire object was fabricated.

No supports structures were required, since overhangs and undercuts were supported by the solid powder bed. This enabled multi-layer production, manufacture of living assemblies and optimal use of the 3D building space.

Upon completion of the build, the build canister had to be allowed to cool down before the parts could be removed from it. This normally took a considerable amount of time. Large parts with thin sections sometimes required as much as two days of cooling time. Normally cooling took place within the build chamber of the machine. This in effect meant that the whole LS system was out of action for as long as the cooling continued; however, certain LS systems, such as those supplied by EOS, enabled the removal of the entire warm building canister for external



cooling, thus allowing the system to be ready for another production run very shortly after completion of the first. This interchangeability of building canisters dramatically enhanced the systems productivity.

When the building canister cooled down sufficiently, the parts could be removed from it. By removing the building canister all loose powder fell away, revealing the powder cakes that enclose the parts. The parts were extracted by carefully breaking the powder cakes. Excess powder was simply brushed or blown away. The loose powder, although damaged, was recyclable, but it had to be refreshed with new powder before reuse. The material in the powder cakes was not recyclable and had to be discarded after the parts are removed from within them. After breakout, the parts could be delivered for post processing or finishing if it was required. Since the objects were sintered, they were porous [14]. In certain instances it might be required to infiltrate the part, especially metals, with another material to improve mechanical characteristics.

Surface finishes and accuracy were not quite as good as with SLA, although ongoing research and development was driving steadily in this direction. Material properties however, could be quite close to those of the intrinsic materials. A variety of thermoplastic materials such as nylon, glass filled nylon, polystyrene, metals, ceramics [14] [34] [45] and alumides were available. The method had also been extended to provide direct fabrication of metal and ceramic objects and tools; however special machines were needed for production in certain of these material groups.

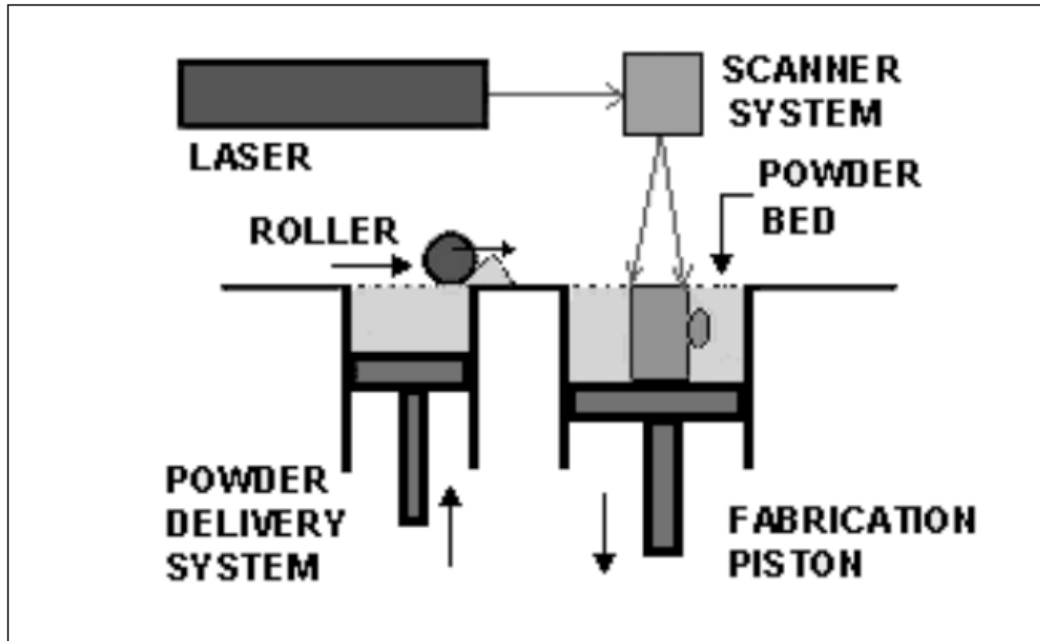

*Figure 8-1: A schematic representation of the selective laser sintering process.*

#### 8.4. CHAPTER SUMMARY

This chapter dealt with the process of laser sintering and although no new DFRM guidelines were derived directly out of this chapter, it proved that the theory upon which the earlier DFRM guidelines that were derived in chapter 4 was sound.

Fundamental differences between the RM process and the conventional manufacturing process, such as the tool-less nature of SFF, had been emphasised once again.

Furthermore, the comprehension of the laser sintering process was required as the fundamental input into the next chapter where this SFF process was integrated into the product development process.

## CHAPTER IX

### 9. THE RAPID PRODUCT DEVELOPMENT PROCESS

#### 9.1. CHAPTER OBJECTIVE

The goal of this chapter was to construct a model for the rapid product development process. This was achieved by analysis of the impact of RM on the conventional model in order to discard all phases that had become redundant and in order to add phases where required. Apart from the process model that was generated in this chapter, valuable information regarding the approach to the RM design problem was also obtained through the creation of this process model.

Summarized, the objectives for this chapter were:

- To establish the impact that RM had on the conventional product development process.
- To develop an RM product development process.
- To note elements that had an effect on DFRM.

#### 9.2. THE IMPACT OF RAPID MANUFACTURE ON THE CONVENTIONAL PRODUCT DEVELOPMENT PROCESS

Once again it was necessary to return to the model of the product development process shown in figure 9.1. It was not difficult to see that the implementation of RM had a great impact on some of the steps in this diagram. The impact was felt heaviest in the refinement and implementation stages of the model, but although the amendments to the ideation phase were only subtle they were just as significant.

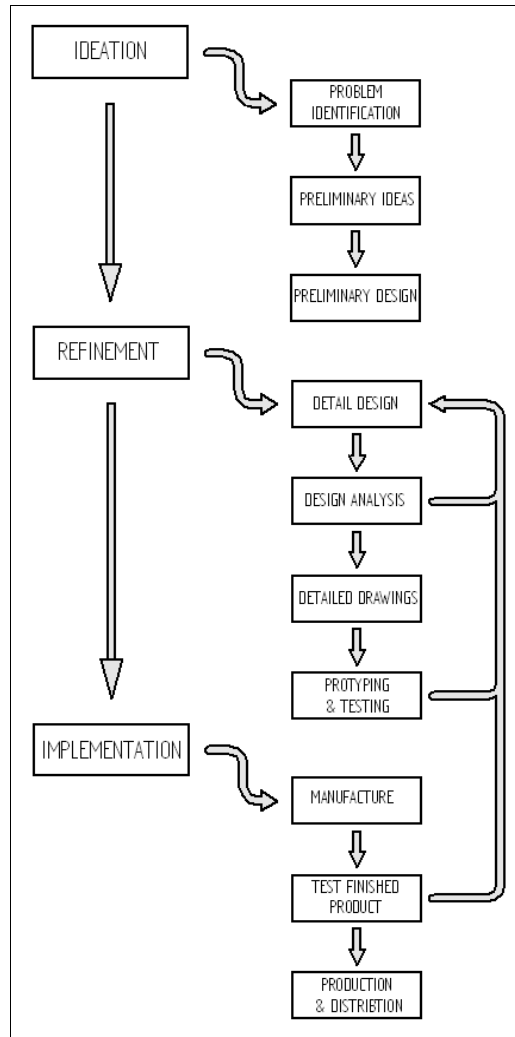

*Figure 9-1: The product development process*

### 9.2.1. IDEATION

#### 9.2.1.1. Problem identification

As in any other field of engineering, a design problem that is to be solved whilst incorporating RM needed to be properly defined, and since RM only provided new means for solving manufacturing problems and none to define design problems the impact that RM had on this phase of the production process will be minimal.

#### *9.2.1.2. Preliminary ideas*

Although the implementation of RM as manufacturing process theoretically allowed complete creative freedom during the brainstorming phase, the tendency among participating parties was not to delve too deep into this afore said creative freedom. It was a common occurrence among designers to become so used to designing for manufacture that it became second nature [9], and since under normal conditions incorporation of DFM from the earliest phases of the product development process had a positive impact on the final product, this was the correct approach. The problem that now arose was that conventional DFM does not apply to concepts that were generated with the eye on RM, since the additive nature of SFF does not conform to conventional manufacturing practices.

When generating ideas with the eventual aim of RM, conventional manufacturing became a proverbial millstone around the neck that impeded the flow of truly creative ideas and drew the focus away from the functionality of the product toward its manufacturability. Applying conventional DFM to the rapid manufacturing ideation phase resulted in the useless containment of creative thinking and the encumberment of some of SFF's key features.

During the preliminary ideas phase of the rapid product development process the designer had to break completely with conventional DFM and focus all attention on ideas that, no matter how bizarre or complex it might seem, could supply possible solutions to the design problem. The same went for these ideas when evaluated in order to select the best solution that proceeded to the next phase; ignore manufacturability and focus on functionality.

#### *9.2.1.3. Preliminary design*

Evaluation of ideas took place in much the same way as in any conventional process, the main difference being that it was no longer necessary to disqualify designs due to aspects relating to their manufacturability. If a part was small, complex and littered with re-entrant features that were virtually impossible to manufacture by conventional methods, so much the better for RM. Product functionality should constantly have been the designer's main concern. Furthermore it was presumed that preliminary design models became more and more CAD based, since it eased the correlation and flow from the preliminary design phase into the refinement stage.

#### 9.2.2. REFINEMENT

The refinement phase of the product development process was the first that underwent physical changes caused directly by the implementation of RM.

##### *9.2.2.1. Detail design*

With reference to section 2.3.2.2, the definition of detail design was the process of detailing materials, shapes and tolerance of an individual product. Although the essence of the detail design phase, that was the definition thereof, did not veer from that of the conventional process that was described earlier, most aspects regarding the implementation thereof needed to be considered from a completely different angle.

The geometric freedom that was afforded by additive manufacturing processes and consequently also by RM, enabled designers to optimise designs by designing parts with geometries that would previously have been impractical. Further optimisation could also be achieved by consolidating assemblies into single parts. As during the preliminary ideas and preliminary design phases, part functionality had to be the main

focus. Geometric freedom could also have a positive impact on part aesthetics and promoted part customisation.

Most manufacturers of SFF systems quoted absolute tolerances for their systems, although the accuracy was usually a factor of the part size and axis of measurement and material used [36] [11]. For most SFF processes accuracy in at least two directions were normally very close to absolute. Conventional design often required the specification of tolerances in order to facilitate interaction with other parts, and while tolerancing on a conventional design was a specified range of allowable dimensional values, accuracy of RM parts was a process specific constant. Tolerancing in RM parts that existed in order to accommodate other parts had to be a designed-in feature and was dependant on the capability of the RM process, the material specified and the fit that was desired.

In the future, when it became possible to mix and grade material in a desired combination and deposit it where in specific areas where it was needed to enhance the mechanical properties of the part, selection of materials for RM parts could become a complex matter. At the time of writing there were only a limited number of materials available for RM, and more often than not the available SFF system dictated which of them could be used. Usually a designer had no more than a dozen materials to choose from. Ordinarily this would have rendered the idea of any design but the most basic unthinkable; however the unique abilities of RM enabled the designer to tailor a specific design to incorporate this impediment.

RM also had a profound effect on DFX. Many factors that were of consequence when designing for conventional manufacture became insignificant when confronted with the unique abilities of RM. However

the most significant impact was felt on the DFM and DFA design approaches.

All RM processes were tool-less processes, which did not involve any melting and subsequent solidification within the confines of a tool. Neither did it involve the extraction of the part from the tool (moulding processes) or vice versa (cutting and other forming processes). In some cases it had not even required any assembly actions. Consequently all DFM guidelines regarding material flow, tool and part extraction and a considerable list of others could be ignored. However the most significant impact of RM was on the guidelines associated with minimizing complex geometries and features [24]. Incorporation of complex features by means of conventional manufacturing was mostly not impossible, only impractical due to the high cost and undesirable lead times associated with the manufacture of part specific tooling, extensive tool set ups, testing runs and prototyping [24]. However as RM was completely tool-less, the part complexity was not important and any complex features produced in CAD could be directly translated into the final product. This was in marked contrast to conventional manufacturing processes.

Due to the layered nature of SFF processes, certain new aspects had to be incorporated within the new design for rapid manufacture (DFRM) guidelines. Central amongst these new guidelines was the orientation of the part in the building envelope. It had already been mentioned that part orientation had a profound effect on build times and surface finish; however, it also played an important part in accuracy and material properties.

The most important DFA guideline, which concerned the reduction of the part count, was easily achievable through RM since the geometric freedom thereof allowed the designer to consolidate parts in ways that had



previously been impossible [24]. In theory RM made it possible to reduce the number of parts in an assembly to just one, whether it be a single exceedingly complex part or a living assembly, though in practice this was not always feasible as parts were generally not being used in isolation and their interaction with other components would impose limitations on parts count [24].

#### *9.2.2.2. Design analysis*

Where conventional manufacturing processes often required designers to focus on manufacturability of a part, RM laid no such restrictions on the designer. The consequent geometric freedom afforded by RM enabled designers to make use of any means at their disposal in order to streamline a design and produce a functionally optimised product.

#### *9.2.2.3. Detail drawings*

The main objective of this phase in the product development process was to record the design for future reference and to communicate the design to the manufacturer. Since RM utilized CAD data directly, the necessity to communicate a design and dimensions was eliminated. The digital CAD model that was created during the design phases could be used just as effectively as the basis for the interaction of other downstream engineering functions as any detail engineering drawings, consequently this whole stage was removed from the RM product development process [35]. The removal of this step required some cultural changes within companies, as drawing-less manufacturing was something that was not common practice [35].

#### *9.2.2.4. Prototyping and testing*

When SFF systems were employed for RM, it became possible to produce rapid prototype parts on the same machines and in the same material that was used for the production of the final products, thus the need for any prototype tooling, and any conventional prototype manufacturing was

obliterated. This led to even faster production of rapid prototypes, which in turn led to shorter refinement cycle times and increased productivity. As the final prototype was essentially the first production part, implementation of RM caused this prototyping and testing phase to merge into the testing of the final product phase. Lastly, implementation of RM implied that the skilled and specialized group of people currently employed in the production of technical prototypes may well be needed to be directed to other areas of product development [35].

### 9.2.3. IMPLEMENTATION

#### *9.2.3.1. Manufacture of tooling, set-up of numerical control programming and training*

RM had an important impact on this expensive and time-consuming process within the product development process. Since the whole RM process was performed on one SFF system, no part specific tooling, machine tools, jigs or special fixtures were required. There was no need to create and test numerical control (NC) or computer numerical control (CNC) programs. Also initial capital investment needed for the purchasing of computer aided manufacturing (CAM) packages to develop NC programs was avoided [35]. Apart from the training that the RM system operator will receive, no training for any other individual was required. In short, implementation of RM as production system implied that this whole phase could be eliminated from the RM product development process.

It was important to note that with the removal of the manufacturing of tooling phase, the CAD modelling phase became the most time consuming aspect of the project [23]. Therefore the speed of the product development process was largely dependant on the skill of the CAD operator.

#### *9.2.3.2. Testing*

The final prototypes produced during the prototyping phase of the product development process were essentially the final end-use parts, and since the manufacturing phase of the implementation stage of the product development process could be eliminated, the testing of the final product phase and the testing of the prototype phases merged and become one.

Another aspect wherein the rapid product development process differed from the conventional process was its ability to make changes to the design at this late stage of development. Unlike the conventional product development process, product defects that were identified at this stage in the production process could be rectified by simply editing the CAD design before the next part was built. Conventionally, such modifications would be very expensive and were avoided at all costs, however RM allowed that changes be made easily and cost effectively.

#### *9.2.3.3. Production and distribution*

During RM, full scale production was done on SFF systems, often on the same systems on which the prototypes were built, thus production ramp-up in an RM environment simply meant setting a machine to produce larger numbers of the parts that had up until then only been produced in small quantities. RM allowed production volumes to be economically adjusted according to demand. Without cost on tooling to amortize into the parts produced, each component could be different, potentially allowing for true mass-customisation of each and every product. With developments in web-enabled software and high levels of computer literacy and internet connectivity at home, the technologies are not far from giving the consumer the ability to modify the design of the product they desired for themselves. Although this was some way off, it was conceivable that if a consumer wanted to influence the design of his new sunglasses, mobile phone casing, steering wheel grip or favourite kitchen

utensil, etc., he could send the data back to the manufacturer who could have it made for specifically them.

Such distributed digital production could lead to a system where the need of inventory, logistical support, and the whole distribution chain would be redundant. In such a system CAD data was sent digitally from the designer to the manufacturing station nearest to the location where the parts were desired. Thus it was expected that there would come into existence a tendency for 'a factory in the home' or at least in the neighbourhood where people could send their own designs, or refer designs that had been purchased, for manufacture. In such a system conventional packaging of products would become an infrequent occurrence and alternative means would have to be utilized to communicate information to the consumer.

### *9.3. THE RAPID PRODUCT DEVELOPMENT PROCESS*

When all novel aspects of RM had been taken into account and applied to the conventional product development process a model of the rapid product development process could be constructed. The figure illustrated the process as a consecutive number of clearly differentiated steps, however it should be remembered that it was actually a simplified representation of a concurrent engineering process where the degree of distinction between the different phases are vague.

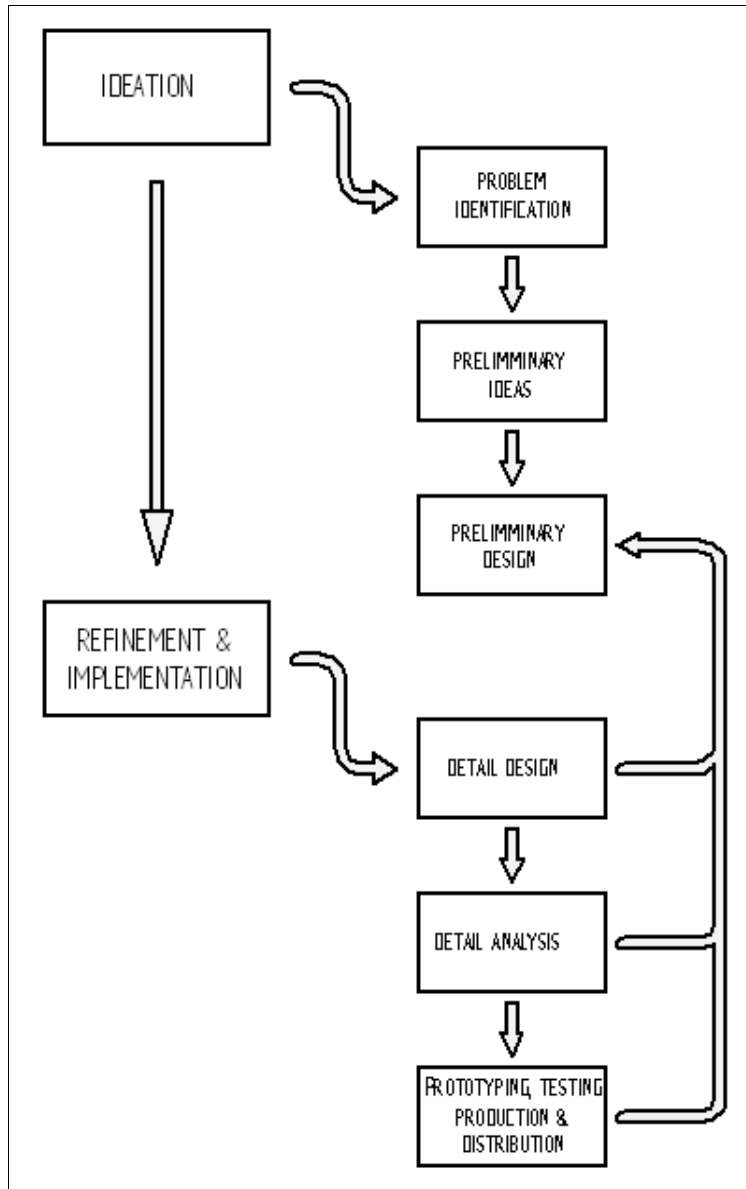

*Figure 9-2: A linear representation of the RM product development process*

Noteworthy results were the elimination of the generation of detail drawings and manufacture of tooling, set-up of numerical control programming and training phases. Furthermore also the merging of the

refinement and production phases and the establishment of a final phase that included prototyping, production, testing and distribution.

#### *9.4. CHAPTER SUMMARY*

The RM product development process model that was developed in this chapter gave insight on the real impact that RM would have on the product development process.

Two major impacts of the RM process were the merger of the prototyping and the manufacture processes, and the complete absence of the detail drawing phase.

The facets of RM that were identified in this chapter that should be emphasised in the DFRM framework were:

- The paradigm shift that is required when a RM design problem is approached.
- The flexibility awarded to RM through the lack of tooling requirements.
- The reduced duration of the RM product development process due to the absence of requirements for detailed drawings and tooling.

## CHAPTER X

### 10. DELINEATION OF DESIGN FOR RAPID MANUFACTURE GUIDELINES

#### *10.1. CHAPTER OBJECTIVE*

To establish the authority of the DFRM guidelines the strategy that was followed to construct this matrix was discussed in the following chapter. Furthermore, the logic behind the method by which it was derived was presented for validation. Accordingly, the objective of this chapter was:

- To add merit to the authority to the DFRM guidelines.

#### *10.2. REGARDING THE APPROACH TOWARD DESIGN AND CONCEPTUALIZATION*

When designing for rapid manufacture, the first progression of actions was not physical; rather it would be a series of psychological decisions that caused a paradigm shift from the conventional manufacturing paradigm toward the less disciplined additive freeform fabrication paradigm. Some of these psychological actions included definite decisions to unshackle the imagination and become creative in order to overcome the inbred conventional manufacturing paradigm. Others required that the designer forget some conventional manufacturing restrictions, so that he could concentrate his efforts on part functionality and not simplicity or manufacturability. DFRM also required the integration of mechanical and aesthetic design; another aspect which most definitely required further psychological changes in the approach of an industrial or mechanical designer toward a design problem.

As RM, and for that matter all SFF technology, was still very young and consequently not fully exploited, it was important to cultivate a culture amongst designers that promote a willingness to experiment and to take

initiative. The true abilities of RM could not be discovered by following a conventional approach.

### *10.3. RELEVANCY OF CONVENTIONAL DESIGN GUIDELINES*

The additive tool-less nature of RM differed from conventional manufacture to such an extent that all conventional design guidelines imposed by the production process became irrelevant. This meant that guidelines such as those imposed by injection moulding regarding wall-thickness, sink marks, mould filling, weld- and meld lines, parting lines, ejection pins, gate marks, and draft angles were not applicable when designing for rapid manufacture.

Design guidelines that exist in order to ensure the simplicity that promote manufacturability and assembly lost most of their significance due to the freeform-ability of RM processes. The freeform-ability allowed economical production of complex geometries and features such as undercuts, blind holes and the like that were typically not practical for production by conventional manufacturing technology.

However, guidelines that concerned detail features, such as bosses, sharp corners, snap-fits and living hinges or screw threads could not be discarded at a glance. It was often the case that these guidelines existed, not due to the inability of the manufacturing process, but in order to help the designer avoid designs that were prone to fail. Therefore conventional guidelines that promote good design practice were still useful and should be kept in consideration.

A further group of guidelines existed, that dictated design according to the properties of the material that was used for production. These guidelines remained relevant in the RM domain if the material that was



used for production was comparable to the material used in the conventional process.

#### *10.4. EXPLOITING THE ABILITIES OF RM AND DOWNPLAYING INCAPACITIES*

As with any manufacturing process, RM had certain special abilities that enabled it to outperform other manufacturing technology in certain fields, and like any manufacturing process, RM technology was hindered by inherent weaknesses that made it inferior to other processes under certain conditions. DFRM guidelines had the task to specify manners in which the novel and unique abilities of RM, such as geometric freedom or digital distributive manufacturing could be utilized and exploited optimally, whilst the restrictions imposed by RM, such as the long build-times, isotropic behaviour of material, lack of accuracy, and effect of build orientation were incorporated into the design with minimal interference.

#### *10.5. CHAPTER SUMMARY*

The DFRM guidelines were constructed by drawing information from three major areas.

- Firstly, the paradigm shift that was required when a designer designed for RM was noted. This series of notes will be made to let the designer know that he was working with a non-conventional process and that he had to remember to approach the design from a slightly different angle.
- Secondly, the conventional manufacturing guidelines that were documented in chapter 7 were analysed so that all aspects of the design for injection moulding guidelines that could be of use in the new manufacturing environment could be recycled
- Thirdly, those strong points, unique abilities and limitations of RM and LS that had been identified throughout the literature

study, as points to exploit or circumvent were added to complete the series of DFRM guidelines.

## CHAPTER XI

### 11. DESIGNING FOR RAPID MANUFACTURE

#### *11.1. CHAPTER OBJECTIVE*

The method that was described in the previous chapter was implemented in this chapter. Accordingly, aspects that were gathered from the entire literature study were combined to form a DFRM framework. Thus, the objective of this chapter was:

- To construct, based upon the literature study, a DFRM framework.

#### *11.2. INTRODUCTORY*

Considering the different levels of RM and conventional manufacture that had been studied, namely the product development process level described in chapters 2, 6 and 9, the high level conventional manufacturing process and the high level SFF description presented in chapter 2 and 3 and the conventional and RM process specific level that was investigated in chapters 4, 6, 7 and 8, it followed naturally that the DFRM framework presented in the subsequent chapter, was broken down into three distinctive categories or levels. Firstly, the highest order DFRM guidelines that were applicable to manufacturing in general. Secondly, a series of general DFRM that was applicable to most (if not all) additive manufacturing processes regardless of the specific manufacturing procedure, and following that, a series of specialized process and material specific guidelines.

#### *11.3. HIGH ORDER DFM GUIDELINES*

High order DFM guidelines were relevant across the board. The rules were just as relevant in the RM domain as in any other manufacturing domain. In truth, the fact that it remains relevant in RM's new manufacturing domain proved that the nature of DFM had not changed entirely when it

was employed for RM. Furthermore, it also indicated summarily that RM was not an omnipotent manufacturing process. Although it was unique and unrivalled in some areas, it was subjected to the most basic rules of manufacturing. Table 11.1 summarized these high order guidelines. It was important to remember that wherever RM parts were used in conjunction with any other parts, conventional DFM and DFA guidelines had to be considered during the part design.

*Table 11-1: High order design for manufacture guidelines*

<b>High order design for manufacture guidelines</b>	
	Limit the number of parts
	Design parts with multiple functions
	Make use of modular parts
	Use standard components in whenever RM cannot provide an alternative
	Design for a specific RM process

#### *11.4. GENERAL DFRM GUIDELINES*

The second class of DFM guidelines that could be defined were general DFRM guidelines. The majority of these were derived by evaluating the novel abilities and restrictions of SFF. Further guidelines were obtained from analysis of the contrast of SFF compared to conventional manufacturing procedure and the impact of RM on the product development process. These guidelines were outlined in table 11.2.

*Table 11-2: Guiding design parameters for RM*

<b>Design for rapid manufacture guidelines</b>	
Paradigm shifts	Additive manufacture was unlike conventional manufacturing and that some conventional manufacturing principles had become outmoded.
	Note that the unrestrained and even undisciplined application of creativity and initiative could result in practical solutions for RM that could give RM an edge over conventional manufacturing.
	Focus had to be on the functionality of the design. Do not allow any aspect of manufacturability to displace it.
	Aesthetic and mechanical design had to be considered simultaneously.
	High levels of customisation were allowed and could easily be attained.
	Part cost was determined by volume, not complexity.
Cost efficiency	Whenever possible part volume had to be reduced.
Accuracy	Accuracy could be maximized by designing for orientation.
	Tolerances had to be included as a design feature
Surface finish	Stair-stepping had to be eliminated on critical surfaces. Further optimisation of surface finish can be obtained by designing for orientation.
Build times	Build times could be minimized by orientating parts in such a way that the height parallel to the direction of growth was minimal.
	Build times could be limited by optimising designs so that the cross-sectional area / laser path was reduced.

*Table 11.2: Guiding design parameters for RM (Continued)*

<b>Design for rapid manufacture guidelines</b>	
<b>Design optimisation</b>	Optimisation for functionality was allowed.
	Functionality could be complimented with part complexity as, for any given volume, complexity was free of charge.
	Part volume could be minimised by optimising part designs.
	Build times could be minimized through optimised designs that require minimal cross-sectional areas that had to be traced by the laser.
	The lack of RM material range could be incorporated or facilitated through design optimisation.
	To ensure minimal post-processing, it was advised to include as many features as possible in the CAD model.
<b>Conventional lower order DFM</b>	All process specific conventional DFM guidelines regarding aspects like material flow, part extraction, tool extraction and insertion, tool wear, material feed etc. become irrelevant.
	All conventional DFM guidelines that promoted limiting the complexity became irrelevant.
	Conventional DFM guidelines imposed by material properties and behaviour remained useful, provided that the material was comparable with the selected RM material.

### *11.5. DESIGNING FOR LASER SINTERING*

Lower order DFRM guidelines were dependant on the RM process and on the type of material used. In other words, these rules were different for every individual RM process and sometimes even varied with the type of material that was used for production. Consequently, such guidelines needed to be derived for every RM process and if the RM process was capable to produce parts in various materials, it had to be reworked and updated for every material class.

LS did have the ability to produce parts in a wide range of materials, but the differences between the material properties made it impossible to create a single set of DFM guidelines for this process. For instance: Although LS created parts in polymeric, metal and ceramic material [14] [34] [45], the elasticity, ductility and brittleness of the three materials were absolutely contradictory to each other, and although each was useful in its own right, it did not do to throw them all together into a single DFSL checklist.

The guidelines that were laid down in table 11.3 were only applicable to polymeric parts that were designed specifically for manufacture by LS. The rules were drawn from the properties of laser sintering and analysis of conventional injection moulding DFM guidelines. Ideally a designer would have used these DFSL guidelines in conjunction with the general DFRM guidelines that were applicable to RM across the board.

Table 11-3: Design for laser sintering guidelines

<b>Design for laser sinter guidelines for polymeric materials</b>	
Breakout	Removal of excess material from the completed part should be considered during the design stages.
	Unless properly supported, intricate and fine external detail had to be avoided, since it complicated and slowed the breakout procedure and often resulted in losses due to fracture.
Isotropic behaviour	Anisotropic behaviour of material had to be incorporated through design analysis and part optimisation.
Design as assembly	Parts had to be consolidated and living assemblies designed whenever possible.
Corners	Sharp corners had to be avoided since it cause stress concentrators that reduce the impact and tensile strength of the part.
	A favourable ratio of radius to wall thickness was 0.6 however this could be increased unlimited if desired.
Wall thickness	For structural integrity wall thickness had to be preferably around 2 to 3 mm.
	Contrary to injection moulding guidelines solid shape modelling was allowed although it increased the build time due to increased laser trace time.
Geometric structural reinforcement	Ribbing and other forms of geometric structural reinforcement could be used for part optimisation but was not mandatory.
Self tapping screws	Self-threading screws could be an economical means of securing separable plastic joints and had to be kept in consideration.



*Table 11.3: Design for laser sintering guidelines (Continued)*

<b>Design for laser sinter guidelines for polymeric materials</b>	
Ribbing	Multiple, evenly spaced ribs were preferred to large single ribs.
Screw thread	External and internal screw threads could be produced in plastic RM parts.
	All sharp interior corners that created stress concentrations had to be eliminated.
	The beginning as well as the end of the thread had to be rounded off in order to avoid notch effects.
	Coarse threads were preferred to fine ones, thus although threads with a pitch smaller than 0.8 mm could be produced they were not recommended.
	The length of the thread used had to be at least 1.5 times the diameter and the section thickness around the hole, more than 0.6 times the diameter.
	The thread had to be designed to start about 0.8 mm from the end of the face perpendicular to the axis of the thread.
	RM screw threads had to be designed whilst part orientation and anisotropic material behaviour was kept in mind.

*Table 11.3: Design for laser sintering guidelines (Continued)*

<b>Design for laser sinter guidelines for polymeric materials</b>	
Press fits	An attempt had to be made to orientate the part in such a manner that the stresses developed by the fit were perpendicular to the growth direction, as the material's ability to withstand stress was much higher in this direction than in other directions.
	The designer should check that the maximum developed stress was below the value that produced creep rapture in the material. It was advised to orientate press fits in such a way that ensured maximum strength of the surrounding RM generated solid material. However RM's geometric freedom combined with analytical optimisation could compensate for material weakness.
	When designing an interference press fit the addition of crush ribs to the inside diameter of the boss was recommended.
	Press fit assembly could be eliminated by combining the two parts in the CAD model.

*Table 11.3: Design for laser sintering guidelines (Continued)*

<b>Design for laser sinter guidelines for polymeric materials</b>	
<b>Mounting Bosses</b>	The bore of the boss had to be deeper than the depth to which the thread will be cut.
	It was possible to produce bosses with in-designed threads, however as self-tapping screws could be used with success, it had to be contemplated whether or not this was worth the effort.
	The bore at the entrance of the boss had to have a short length with a slightly larger diameter.
	Again it was advised to orientate bosses, like press fits, in such a way that ensured maximum strength of the surrounding RM generated solid material.
<b>Cylindrical and spherical snap fits</b>	It was essential to keep the wall thickness constant throughout.
	There had to be no stress risers.
	The snap fit must be placed in an area where the undercut section could expand freely.
	The ideal shape for this type of snap-fit was circular.
	If cracks developed due to the layered nature of RM and cannot be avoided by changing the overall design or orientation of the part, the section could be strengthened by means of a bead or rib.

*Table 11.3: Design for laser sintering guidelines (Continued)*

<b>Design for laser sinter guidelines for polymeric materials</b>	
Snap fits with cantilevered lugs	Cantilevered lugs had to be designed in a way so as not to exceed allowable stress during assembly operation.
	Too short a bending length often caused breakage.
	Cantilevered lugs had to be dimensioned to developed constant stress distribution over their length. This was achieved by providing a slightly tapered section or by adding a rib.
	Special care had to be taken to avoid sharp corners and other possible stress concentrations.
	When a fracture of the snap-fit occurred as a result of overloading during the joining operation, the cross section did not summarily have to be increased; the hook should rather be designed to be more flexible.
	On account of the frictional forces and stresses that appeared at the point of joining, all angles of joining had to be chosen to be no larger than 60°.
	The cross sectional orientation of cantilevered lug snap fits had to be perpendicular to the growth direction as this ensured maximum strength and flexibility of the part.

*Table 11.3: Design for laser sintering guidelines (Continued)*

<b>Design for laser sinter guidelines for polymeric materials</b>	
Internal hinges	The thickness of a living hinge had to be approximately equal to the sidewalls of the part.
	Due to the necessary stiffness of the hinge action, the thickness of the web had to be at around half the wall thickness but it was not recommended that is less than 0.125 mm.
	The length of the web to thickness ratio had to be no less than 3 to 1.
	It was vital to ensure that the cross-sectional growth orientation during the building operation was perpendicular to the growth direction (perpendicular to the hinge's bending action) so that entire cross sectional layers could stretch to give a strong, pliable hinging section.

## *11.6. CHAPTER SUMMARY*

In this chapter three basic sets of design for manufacturing guidelines were developed.

- A high level DFRM grid that is relevant across the board.
- A design for rapid manufacture grid that stated design guidelines that were applicable to all RM designs regardless of the SFF process that was employed to do the actual manufacture.
- A very specific set of design for laser sintering guidelines that were only applicable when LS were employed for RM on the condition that the parts that were produced in polymeric material.

## CHAPTER XII

### 12. LITERARY CASE STUDIES

#### *12.1. CHAPTER OBJECTIVE*

Theoretical information gathered through all the preceding sections was used to develop the DFRM framework in the preceding chapter, and although the theory was sound, the guidelines had yet to be verified in the actual workplace. Accordingly, as a first attempt to validate the DFRM guidelines, the rules were subjected to inspection through a number of literary case studies. In short:

- The aim of this chapter was to verify the legitimacy of the developed DFRM structure.

#### *12.2. BAFBOX CASE STUDY*

The following case study was conducted by the Rapid Manufacturing Research Group of the University of Loughborough. It was extracted from two articles [24] [23], firstly, *Material and design considerations for rapid manufacturing* published in 2004, and secondly, *Design opportunities with rapid manufacturing*, published in 2003. Both were compiled by Hague, Mansour and Saleh.

##### 12.2.1. INTRODUCTORY

Bafbox is an Oxford based company that manufactured custom designed plastic enclosures without involving expensive tooling. The manufacturing technique that was used to produce these plastic enclosures was based on flat plastic-sheet fabrication methods. Although these sheet fabrication methods were relatively simple and inexpensive, it did limit the design opportunities. The company wanted to extend the design opportunities offered and accordingly had to consider alternative fabrication strategies. Due to the low production volume that was required

by Bafbox, RM could offer the supply and the sought after design freedom in conjunction with the desired economic production.

The aim of this case study was to investigate a new industrial design and manufacture strategy for an existing Bafbox product. The product chosen for the investigation, which was typical of the components that were produced by the plastic-sheet fabrication method used by Bafbox, could be seen in figure 12.1.



*Figure 12-1: The original Bafbox product*

#### 12.2.2. LIMITATIONS OF THE PRODUCT

The fabrication system that was currently used by Bafbox limited the designer's concept creativity and design possibility. It was impossible to produce aesthetically attractive surfaces by the flat plastic-sheet fabrication method; consequently the boxes were mostly angular. The constant wall thickness of the material, normally only two different standard wall thicknesses were used, reduced the scope of the product design even more. Additionally, most enclosures produced by plastic-sheet fabrication required supplementary assembly steps as this manufacturing process necessitates that the products be made in two or three separate components.

### 12.2.3. DESIGN CRITERIA

The criteria for the new design were based on the following points:

The new design had to accommodate the existing engineering parts.

RM technologies had to be utilized to produce a more aesthetic and ergonomic design.

A reduction of components in order to simplify assembly had to be considered.

### 12.2.4. CONCEPT CREATION AND MANUFACTURE OF PARTS

Following the initial specifications, the concept generation process began with sketches like the ones in figure 12.2 and eventually ended with the 3D CAD model depicted in figure 12.3, which could be exported in .STL format and was used for the additive manufacture.

In this particular case the parts were manufactured on an SL7000 stereolithography machine. The total build time for five products was 18h. On top of this, came the finishing which took another 5h. The five parts were orientated for best all-round surface finish. In order to enhance the appearance of the product after manufacture, further surface processing and coating were necessary.



*Figure 12-2: Preliminary design sketches*





*Figure 12-3: The finalised CAD model*

#### 12.2.5. COMPARISON OF DESIGNS

In table 12.1 a comparison between the original Bafbox design and the RM product was made. All the problem areas were successfully addressed. Figure 12.4 presented a photograph of the completed SLA product.

*Table 12-1: A comparison of the RM and original Bafbox*

<b>Original Box</b>	<b>New Design</b>
<b>Initial problem</b>	<b>Advantage</b>
Square flat surfaces	More attractive and stylish shape
Constant wall thickness	Design with recurrent structure features
Too many parts for simple inner component	Reduced part count from 3 to 1
Limited choice of radius giving limited ergonomics	More rounded for aesthetic and ergonomics



*Figure 12-4: The final SLA product*

#### 12.2.6. DISCUSSION

There were several benefits of RM that had been derived from this case study. The RM technologies opened up a variety of benefits within the product design and manufacturing phase. The ability to manufacture and sell new products in a short time enhanced the sales opportunity and potentially created new markets for Bafbox. The final design could not be manufactured with Bafbox's current technologies as the design had departed from the flat/angular designs produced with the current manufacturing process. One of the obvious examples from the Bafbox project was the rear of the new design, which had a re-entrant surface for covering the inner component. Such a feature would have resulted in more expensive tooling if the parts were manufactured by means of injection moulding.

##### *12.2.6.1. CAD issues*

One of the most important issues to be overcome by RM in the future would be the limitations and difficulties of using current CAD systems. The CAD design produced was, in essence, what was originally sketched but lacked some of the spontaneity of the creative design sketch. This difficulty of interpreting the design intent was compounded by the fact that CAD systems were "expert systems" that required extensive training.

One of the advantages of RM would be the possibility of producing custom designs; however, there was a dichotomy between an increase in custom design that necessitated more CAD input and the difficulty in producing those designs using current CAD. Considering the current design, some of the design ideas were killed by the constraints of the current CAD design systems. Some of the initial designs were adventurous and organic; these would have been ideal for the RM research, but would have been complicated to produce in CAD systems and also would have been time-consuming.

The result was that the initial creative idea did not have to be produced faithfully as some complicated details had to be changed or ignored through the current CAD package. It had actually to be noted that the time to produce the CAD model far outweighed the time to actually manufacture the product. In conventional manufacture, the tooling to produce the injection moulded components (for example) usually made up the longest part of the product development process. When utilizing RM, the CAD required more time and therefore became the bottleneck. The complexity of the CAD systems also had the effect of limiting those who could and wanted to use the RM technologies. The “ease of use” requirement had traditionally been the stumbling block for most existing CAD systems.

#### *12.2.6.2. Assembly constraints*

Unfortunately, a freeform design that completely capitalized on the freedoms given by RM was not necessarily suitable to receive the components and mechanisms required to make it work. In this case the organic freeform shapes were not suited to house the square internal components. The outcome of this was that a design that was produced for RM was basically not limited by the constraints of conventional

manufacturing, but by the fact that products required components to be assembled inside them.

#### 12.2.7. CONCLUSIONS

RM would have had a profound effect on the way designers worked. Instead of the conventional approach where a mechanical design team consisted of an industrial designer who generated the concept, mechanical engineer, who was responsible to incorporate the “internals” into the design and consider the manufacturing route, and toolmaker, who obviously designed and manufactured the tooling, a RM design team could typically consist of only one person that ideally had to be a hybrid designer who were master of both the mechanical and the industrial design domains since the ability to “print” a design directly placed all the responsibility of the design on a single designer.

Designing for RM would actually break down and become designing for SLA or LS. A number of common RM rules applied, but material properties would be important and thus characterization of these properties by companies would be key.

Although the designer was designing parts specifically for RM he or she still needed to take aspects such as assembly (inclusion of non-RM components), maintenance, disassembly etc. in regard. Design for RM was not a stand-alone part of design, but something that had to be incorporated into the overall system.

With the advent of the RM technologies, designers would be able to manufacture any freeform shape that can be designed and would no longer be constrained by the limitations imposed on them by either the conventional moulding process or the tool making process.

The conversion of the industrial design sketches to a useable CAD model was non-trivial, as there was difficulty in re-producing the exact design intent.

As all tooling was eliminated, the CAD modelling phase became the most time-consuming aspect of the project and therefore CAD became the bottleneck that required a skilled operator to produce.

### *12.3. FRONT PLATE OF A DIESEL FUEL INJECTION SYSTEM*

The following case study is extracted predominantly from the article by Hague, Mansour and Saleh mentioned in section 3.1 *Material and design considerations for rapid manufacturing* [24]. However, it was supplemented by extracts from *Rapid manufacture: An industrial revolution for the digital age* by Hopkinson, Hague and Dickens [27].

#### 12.3.1. INTRODUCTORY

Figure 12.5 was a three dimensional view of the CAD model of a front plate of a fuel injection system that had been designed for diesel engines. The pump was fitted to either end of the cylinder head, or to the timing case of an engine. The operating temperature was as high as 200 °C due to a heat-sink effect. It had to cope with exposure to water, oil, diesel fuel and salty spray. The environmental testing and usage ranged from -40 to +140 °C.

The first batch of these parts was produced through investment casting followed by a number of machining operations. Later on the production parts were likely to be gravity castings, which were being developed at the time that the original articles were published. The produced casting had subsequently undergone secondary operations that consisted of machining (drilling holes with long gun-drills), deburring, resin impregnation to avoid any porosity and finally the assembly of blanking balls to block off the long drilled holes. Cleanliness was critical with these

plates, so washing and sealed packaging was the final activities at the manufacturers before the parts were shipped for final assembly.

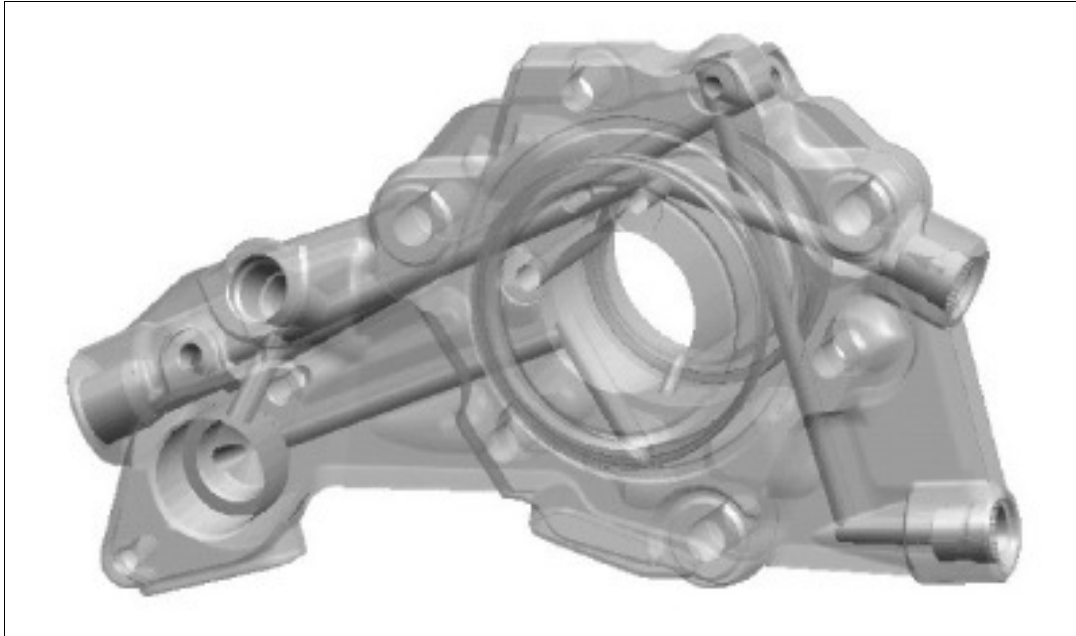

*Figure 12-5: CAD representation of a front plate of a diesel fuel injection system.*

### 12.3.2. REDESIGNING FOR RAPID MANUFACTURE

The process that was currently employed required dedicated machine tools and gun-drills in order to produce the long holes that were subsequently required to be blanked off. Figure 12.6 showed a CAD model of such a plate with holes numbered 1-4 that needed to be blanked off. This blanking off was an expensive and time-consuming process. Furthermore, these blanked holes dramatically increased the possibility of the part developing leakages during its lifetime. Such leakages were not only messy; it also presented a potential safety hazard. In addition, the inability to create no-straight galleries had imposed some constraints regarding facilitating low-pressure circuit fuel flow and a small footprint for installation on different engine sizes.

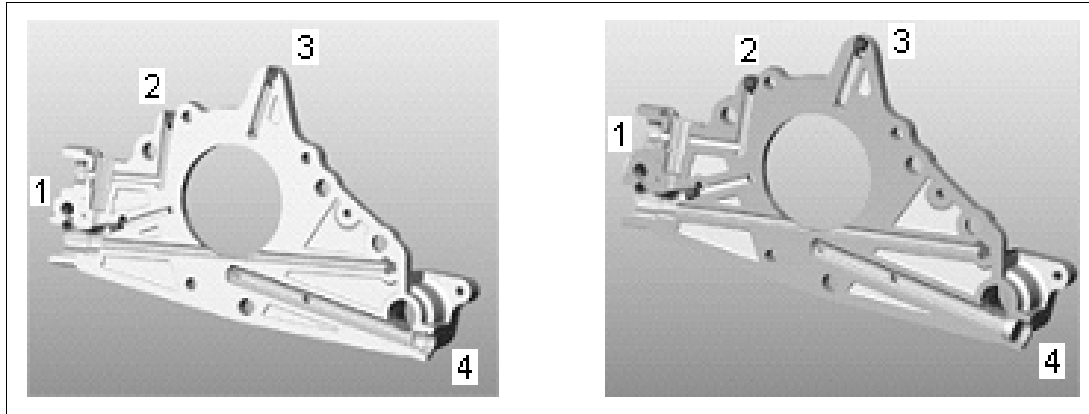

*Figure 12-6: A sectional view through the diesel injection system.*

The production company were investigating the possibility of using injection moulding for producing this front plate. Concurrently with the advent of properties of RP and RM materials, a feasibility study of its manufacturing by a plastic RM technique had also been considered.

Consequently the front plate was redesigned for RM. The simplest approach to this RM redesign was to maintain the overall design of the part and only eliminating the secondary drilling and blanking operations. Such a design was shown in figure 12.7. This figure showed the sectional view of the SLA part. Note the improvements that had been made through the addition of the blind galleries and non-straight hole that had been incorporated in the design.

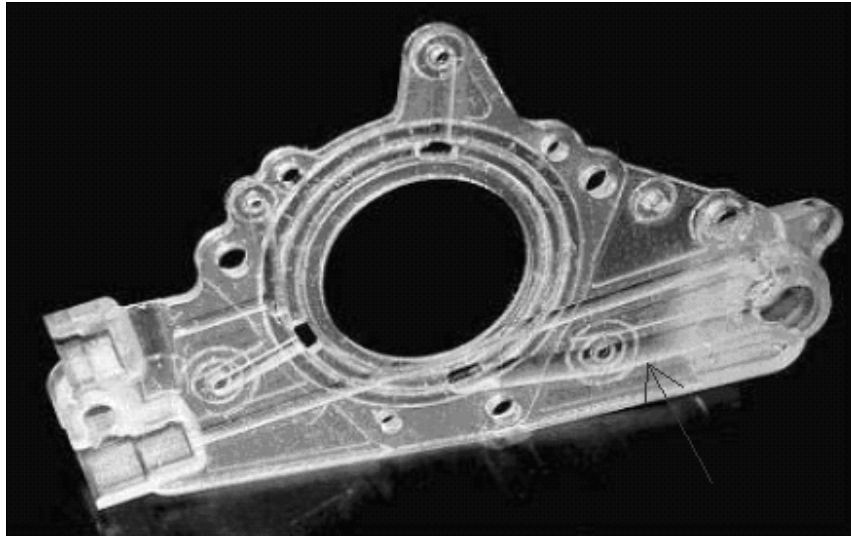

*Figure 12-7: A sectional view through a SLA front plate of a diesel injection system.*

If the designer went one step beyond the obvious redesign and moulded the design around the capabilities of RM, it became possible to optimise the design. Figure 12.8 showed the original design of the front plate in comparison to the RM redesign. On the right hand side was a design of a diesel injection system that was optimised for functional and mass properties that could only be manufactured by RM. The conventional design that was constrained by conventional manufacturing techniques was depicted on the left.

Through this redesign a number of limitations associated with conventional manufacturing processes had been removed. The potential benefits gained were considerable. By adopting RM techniques it was possible to eliminate the extensive secondary operations that was needed in conventional manufacturing, creating encapsulated blank holes, introducing a labyrinth of non-straight holes that not only improved the fuel flow path, but that reduced the part foot print and thus minimized the material usage. In addition blanking holes had been eliminated, thus removing the potential of fuel leakage during service. Table 12.2 gave a



further comparison between the various features offered by the two manufacturing processes.

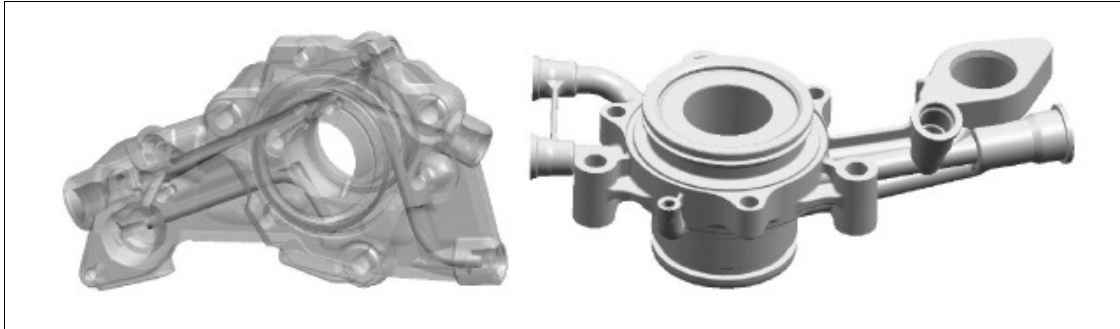

*Figure 12-8: An optimised RM diesel injection system design compared to a conventional design.*

*Table 12-2: Comparison of features offered by RM and conventional manufacture*

<b>Feature</b>	<b>RM Approach</b>	<b>Conventional Approach</b>
Elimination of secondary machining	Yes	No
Introduction of straight holes	Yes	Yes
Elimination of blanking off holes	Yes	No
Creating blank holes	Yes	No
Removal of draft angles	Yes	No
Non straight flow path	Yes	No
Selecting material with the correct properties	No	Yes

Unfortunately the major limitation associated with RP and RM processes was the selection of suitable material to withstand the operating environment for this part. At the time of publication the usage of metals in RP and RM was limited; therefore the only alternative was plastic (thermoplastics and thermosets) which did not satisfy the operating temperature range of between -40 to 140 °C as was specified by the producer.

### 12.3.3. CONCLUSION

RM made it possible for designers to create more streamlined and refined designs. RM opened avenues in part optimisation that had never been explored before.

When designing for RM one had not only to complete the obvious challenges, the designer had always to attempt to improve and enhance the design. If the designer of this front plate was content with achieving his primary objective, that of eliminating the post processing, he would never have dreamt about the possibility of improving the functionality of the part or reducing the material usage. Only through such innovative approaches could the real power of RM be utilized.

The limited range of materials and the limited availability of that material's properties hampered the widespread use of additive manufacturing processes as mainstream production systems. If this hurdle was overcome the implementation of RM would gain with leaps and strides.

### *12.4. CHAPTER SUMMARY*

In spite of the fact that SLA and not LS was used to manufacture the parts that was presented in this chapter, it was still possible to verify a number of high level aspects of DFRM from the case studies.

In the first place the Bafbox case study motivated all DFRM guidelines that were shaped around the required paradigm shift as it proved that the conventional product development process would not necessarily be followed when products were designed specifically for RM. This Bafbox case study also provided proof that it was not only advantageous to consolidate a number of parts into a single item, but that the implementation of RM technology made this relatively easy.

The second case study provided substance for the claims made regarding the paradigm shifts that were required before a RM design problem was tackled. It further proved that the functionality of parts that had long played second fiddle to their manufacturability could now take up a leading role. Through the implementation of RM, part optimisation could be taken to a whole new level. However, the limited number of RM materials and the unknown properties associated with these materials was at the time a major hurdle that stood in the way of full scale implementation of RM.

Both cases emphasised the fact that design for assembly and the specific aspects of part assembly in the specific environment were factors that had to be recognised regardless of whether a design was aimed specifically at RM or not. These case studies further also proved that the tool-less nature of RM technologies enabled designers to manufacture any geometric form that they desired and that in the RM arena they are no longer constrained by the limitations imposed on them by any conventional manufacturing process.

The last points of note that were established through these case studies were:

- That the manufacturing time involved with the implementation of RM was indeed a fraction of the time required by conventional methods.
- That CAD issues, which in the conventional manufacturing arena had produced only a limited amount of pain, were moved to the forefront in the RM product development process.

## CHAPTER XIII

### 13. EXPERIMENTS

#### *13.1. CHAPTER OBJECTIVES*

The following test was conducted in order to determine the legitimacy of the claims made in the literature study regarding the material properties and behaviour of the LS material.

Accordingly, the objectives of this chapter were:

- To investigate the isotropic / anisotropic behaviour of additive manufactured material.
- To investigate the influence that the height in the building envelope would have had on the material properties of the additive manufactured material.
- To attribute quantitative values to the material properties of the LS material that could validate theoretical values.

#### *13.2. MATERIAL PROPERTIES TESTING – TENACITY*

##### 13.2.1. GENERAL OVERVIEW

In the detail design of any functional part the properties of the part's material played a vital role. In general most engineering material behaved isotropic however, due to the additive layer-wise manufacturing technique that were employed by LS, it was necessary to evaluate whether the solid material that was produced by the RM system behaved in an isotropic or anisotropic manner. If material produced by RM did behave in an anisotropic manner the impact on DFRM would have been tremendous.

### 13.2.2. THEORETICAL OVERVIEW

The tensile test was used to evaluate the strength of materials. Accordingly, the tensile strength of a material was defined as the maximum force required to fracture in tension a bar of unit cross-sectional area [25].

In practice this experiment was conducted with a test piece of a known cross-sectional area which was gripped in the jaws of a testing machine and subjected to a tensile force that was increased by suitable increments. For each increment of force the amount by which the length of a pre-determined 'gauge length' on the test piece increased was measured by some device. The test piece was then extended in this way until it failed.

There were a number of different test sample variants available for this test. For metals with a thick cross section a 12.7 mm (0.50 in) diameter round test piece was preferred, while flat test pieces were used for metal sheets [50]. For polymeric materials flat test pieces were generally prescribed [42].

The force data that could be obtained from the test could be converted to engineering stress data and a plot of engineering stress versus engineering strain could be constructed. There were four mechanical properties of material that were of importance to this investigation that had to be obtained from the tensile test, namely the modulus of elasticity, the yield strength at 0.2 percent offset, the ultimate tensile strength and the percent elongation at fracture [50].

#### *13.2.2.1. The modulus of elasticity*

In general metals and alloys showed a linear relationship between stress and strain in the elastic region of the stress-strain diagram that was described by Hooke's law [50].

$$E = \sigma/\varepsilon \dots\dots\dots 12.1$$

Where  $\sigma$  was the stress,  $\varepsilon$  was the strain and  $E$  was the modulus of elasticity or Young's modulus.

Hooke's law implies that for an elastic body, the strain produced was proportional to the stress applied. Young's modulus was in fact a measure of the stiffness of the material in tension [25] and was related to the bonding strength between the atoms of a material [50].

#### *13.2.2.2. The yield strength*

The yield strength was an important aspect for use in engineering structural design, since it was the strength at which the material began to show significant plastic deformation. Because there was no definite point on the stress strain curve where elastic deformation end and plastic deformation begin the yield strength was chosen to be that strength where a definite amount of plastic strain had occurred. This point was normally chosen as the point at which 0.2 percent plastic deformation had taken place.

#### *13.2.2.3. The ultimate tensile strength*

The ultimate tensile strength was the maximum strength reached in the engineering stress strain curve. If the specimen developed a localised reduction in cross-sectional area, the engineering stress decreased with further strain until fracture occurs since the engineering stress was determined by the original cross sectional area of the specimen. The more ductile the material was the larger the reduction in cross-section before failure occurred.

Mathematically the ultimate tensile strength could be described as

$$\sigma_s = F_{max} / A \dots\dots\dots 12.2$$

With  $\sigma_s$  the ultimate tensile strength,  $F_{max}$  the maximum applied force and  $A$  the original cross-sectional area.

An important point to understand in respect to engineering stress-strain diagram was that the actual stress of the material continues to increase up to the point of fracture. It was only because the original value of the cross-sectional area was used to determine the engineering stress that the stress on the engineering stress-strain diagram decreased at the later part of the test.

*13.2.2.4. The percent elongation at fracture*

The amount of elongation that a specimen underwent gave an indication of the material's ductility. Ductility was most commonly expressed as percentage elongation. In general it is accepted that higher the percentage elongation, the more ductile the material. As already mentioned an extensometer could be used to measure the strain during the tensile test. After the specimen failed the total elongation could be determined by fitting the pieces together and measuring the distance with callipers.

The percent elongation could then be calculated from the equation

$$\% \text{ elongation} = (l - l_0) / l_0 \times 100\% \dots\dots\dots 12.3$$

With  $l$  being the final length and  $l_0$  the initial length

The percent elongation at fracture was not only of importance because of its connection to ductility but also as an index of the quality of the material. If porosity or inclusions were present in the material, or if any other damage had occurred, the percent elongation of the specimen tested decreased below normal.

### 13.2.3. EXPERIMENTAL SETUP

The samples for this experiment were produced on an EOS P380 LS system and the material was PA2200 polyamide. The following figure showed the three primary build-orientations in which the test pieces for the isotropy tests were produced. These test pieces were constructed in compliance with the SANS 527 standards and the tensile tests conducted accordingly. Three sets of samples were built, each on a different level in the build envelope. Hence, the test results not only shed light on the isotropic or anisotropic behaviour of the material, it also provided information related to the effect that the height at which the parts were grown in the building envelope would have on the material properties.

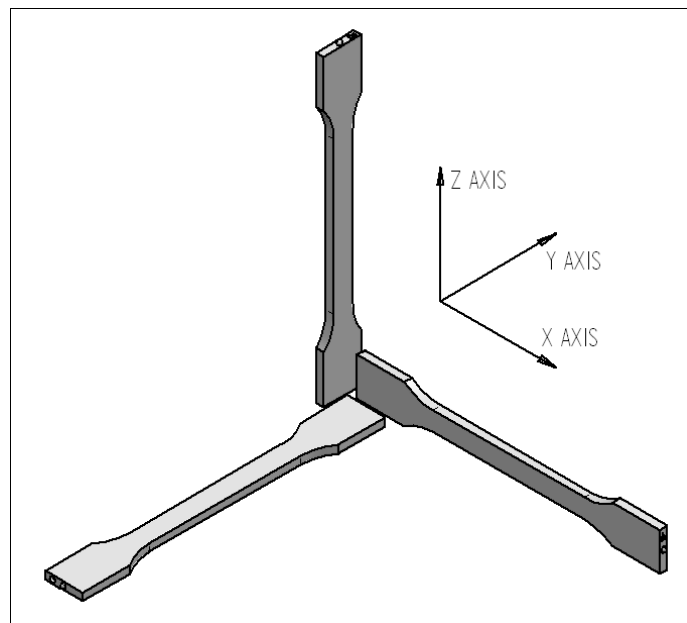

*Figure 13-1: The primary build orientation in an LS build envelope.*

### 13.2.4. RESULTS

The material strength of LS parts in the Z-direction, that was the direction parallel to the growth direction, displayed a consistent tendency to have inferior material properties when compared to the samples produced in other directions. In fact the variance between the actual tensile strength



measured in the Z-direction and the results that were published by the supplier differed to such an extent that the test were rerun. Analysis of the results of the second test, which deviated yet again from the expected value, indicated that factors such as the exposure time and the intensity of the laser had a significant effect on the quality of the material produced.

In both experiments the tensile strength of parts grown in the X and Y-directions were significantly higher than parts grown in the Z-direction and much more in line with the material properties for PA2200 polyamide that was published by the supplier.

The results of the first test also indicated that there was significant variation in the material properties caused by the variation of the height in the build envelope. The largest difference in material properties due to the difference in height occurred in the Z direction. Variation in the level in the build envelope for test pieces built in the X and Y-direction was less however the variance is significant neglected summarily.

#### 13.2.5. CONCLUSIONS AND DISCUSSION

The numerical results of the tensile tests was not published here as the experiments and the subsequent discussions with the supplier clearly indicated that there are additional variables beyond the part orientation and the level in the build envelope, that can influence the material properties of LS parts. Some of these factors could include the exposure and the intensity of the laser. Unfortunately, the magnitude and the many variables that could come into play, prohibited thorough analysis of the material properties of LS parts to be included into the scope of this research project.

In spite of the fact that a comprehensive study of the material properties of LS parts and the variables that could influence them was not undertaken, the results obtained from the tensile tests did indicate that it

was possible to produce LS material with properties that could be classified as anisotropic in all three directions<sup>6</sup>.

Although there was a definite amount of variance between the material properties at differing heights in the building envelope, the results did not give any indication that could lead to the conclusion that there was a pattern in their occurrence. It was believed that the variance was due to factors that are not necessarily related to the difference of build level height.

### *13.3. CHAPTER SUMMARY*

The experiment proved that LS material had a tendency to display dissimilar behaviour in different directions. Furthermore the experiment also indicated that the material properties in the Z-direction could be expected to be inferior to the material properties in other directions.

The experiment did not prove conclusively exactly what variables had an effect on the material properties of LS parts.

Further analysis would be required to give a clear indication of the exact values of the material properties of the PA2200 polyamide.

---

<sup>6</sup> Discussion with the supplier brought to light that the tensile strength listed in the P2200 material data sheet has a tolerance of 6.6 %.

## CHAPTER XIV

### 14. EXPERIMENTAL CASE STUDIES

#### *14.1. CHAPTER OBJECTIVES*

Verification of the DFRM framework that was developed in chapter 11 continued in this section. However in this section the verification was done through a series of case studies that were specifically designed to test certain abilities of LS or fell within the normal scope of work of the author. Summarized:

- The aim of this chapter was to verify the legitimacy of the developed DFRM structure.

#### *14.2. SLIDING DOOR HANDLE*

##### 14.2.1. OVERVIEW

The parts shown in Figure 14.1 formed a special handle that was used for the opening and closing of small glass sliding doors. The handle was secured onto the glass panel by clipping the two parts into one another through holes in the door. Due to a lack of strength in the load bearing members the original design repeatedly failed. To be more specific, the pins that protruded through the glass door often broke. The requirement for these injection moulded handles were about 400 per month, and since these parts are mostly used for the replacement of broken parts, this figure was expected to decline significantly once the problems with the strength of the design were solved.

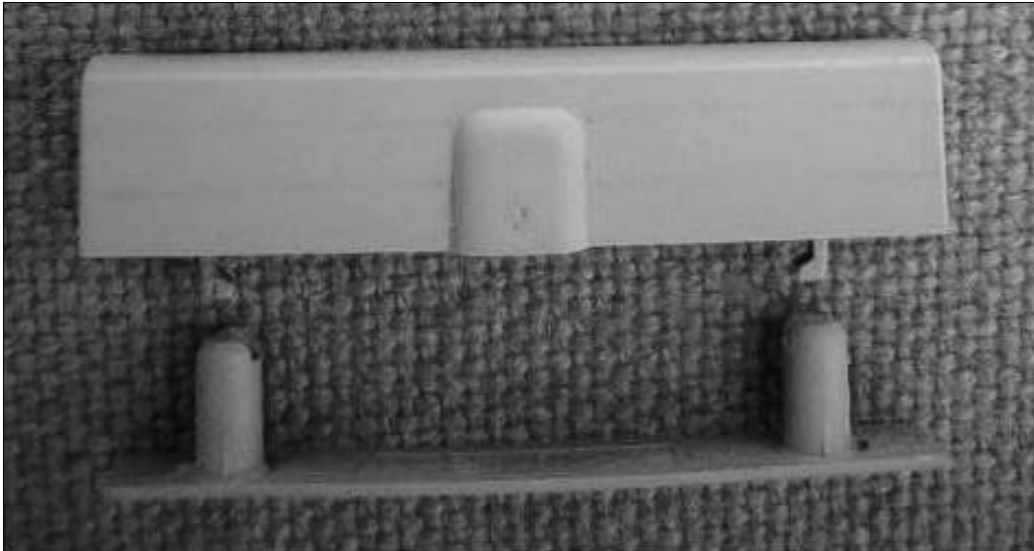

*Figure 14-1: Injection moulded door handle*

#### 14.2.2. CURRENT PRODUCTION METHOD

Both components of the handle were currently made by means of injection moulding. In order to produce a mouldable part this design had been governed by the DFM guidelines of injection moulding. In this instance, the combination of the DFM guidelines and the specified size of the part imposed heavy restrictions on the size of the load bearing surfaces. Unfortunately, these requirements dictated the design to such an extent that part manufacturability overshadowed part functionality, and thus, as was often the case, manufacturability was attained at the cost of functionality. In this case the load bearing features were reduced to such an extent that they had become unable to withstand the load that they are subjected to for more than a few cycles. In other words the DFM guidelines that the designer had to consider when designing parts for this specific production method actually forced a second rate design, and was in this case more of a hindrance than a help.

#### 14.2.3. OBJECTIVE OF THE REDESIGN

The main objective of the redesign was to improve the joining mechanism in such a way that the load carrying features would be able to withstand

the shear forces to which it had to be subjected to when the sliding doors were opened and closed repeatedly. These changes had to be made without any alterations to the outer geometry of the parts. In other words a design was required that was aesthetically similar to the injection moulded counterpart, but had a longer lifetime due to the improvement on the joining mechanism and load carrying capabilities.

#### 14.2.4. RM DESIGN

Working on this design, the first problem that arose was the limited space. The size of the handle and the designer's inability to change the outer dimensions restricted one to a very small usable surface area. It was exactly this limited area that was responsible for the inability of injection moulding to produce the handle. By using any freeform fabrication method as production process, this problem could be sidestepped by producing undercuts in the handle that could be used to secure snap-fits, thus allowing the use of all the available useable surface area for cut-outs that could accept the load bearing pillars. The result was a much stronger handle which did not deviate from the original outer geometry. Unfortunately, unlike its injection moulded counterpart, this snap-fit on the LS design was a permanent fixture. Once engaged the only way to disengage it was by breaking the two pieces apart.

Figure 14.2 was a drawing of the final design. Note the undercuts in the grip piece and the crush ribs on the load bearing pillars.

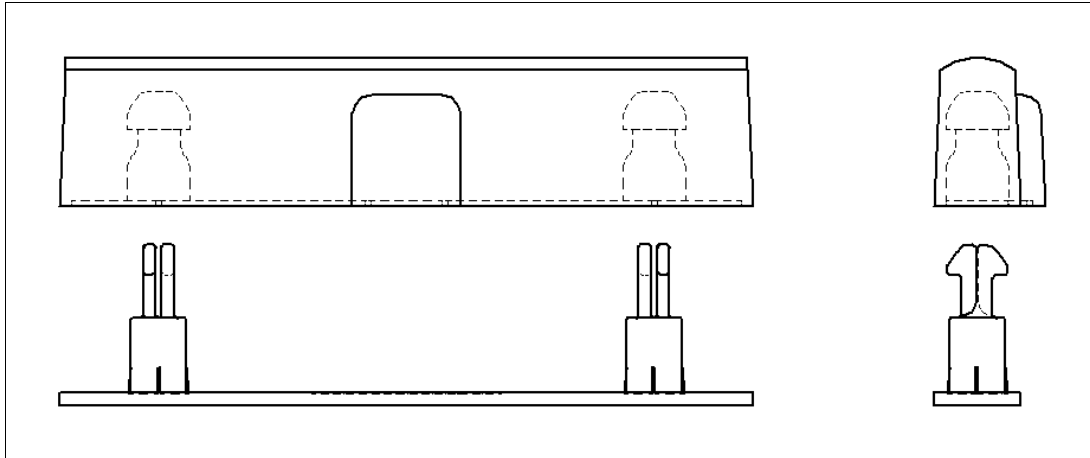

*Figure 14-2: Sketch showing the undercut and snap-fits of the RM door handle*

In figure 14.3 a CAD rendering of the final design and the actual LS part was depicted. Note that the text was obscured on the LS model due to the rough surface finish. Also note the stair-casing effect on the non-parallel sides of the handle. The crush ribs that were present on the CAD model were absent on the LS part. These were broken off during breakout.

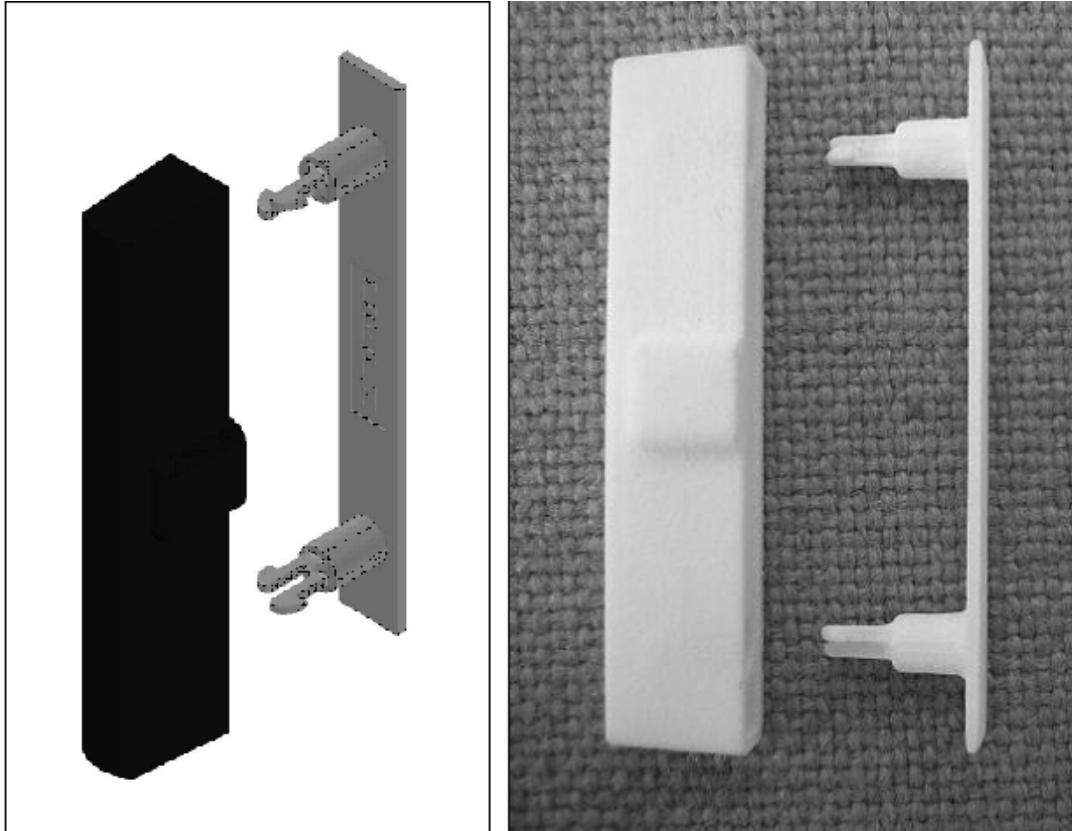

*Figure 14-3: A CAD rendering of the final handle design in comparison with the actual LS part.*

#### 14.2.5. RESULTS AND CONCLUSIONS

By employing LS to produce the handle instead of injection moulding, a much stronger part was produced since the LS design was not governed by DFM guidelines that demanded constant wall thickness or consideration of extraction from the mould. LS could create parts with thick solid sections.

Conventional DFM guidelines for injection moulding did come in handy with the design of the snap-fit. Since the material of the LS part and those commonly used for injection moulding behaved similar, most of the principles that were applicable when designing snap-fits that were optimised for injection moulding were also applicable when designing a cantilever snap-fit for a LS part.

Since LS was a SFF process that made use of powder and not liquid as raw material, it was necessary to consider the powder removal process. The designer had to keep in mind that the powder around the outside of the part, and, if the part has internal geometry, the powder that was clotted inside the part had to be removed.

The fine detail such as the crush ribs and the text that was incorporated in the CAD design, proved to be too fine. Not that the machine could not manufacture it, but because it was broken or brushed off during breakout. Very fine and intricate features should preferably not be incorporated in a LS design since it was very likely that they would be obscured by the coarse surface finish or be damaged during breakout.

As far as build orientation was concerned, the crucial factor was not the outer surface finish, since additional finishing was planned. The critical feature on the front component was the entry holes at the back of the piece. Optimum orientation for accuracy and inner surface finish on these features required that the holes faced the laser squarely. Coincidentally this was also the build orientation that would deliver the shortest build time, since the shortest side of the handle faced parallel to the growth direction.

The strength of the pillars, flexibility of the snap-fit and to a lesser degree the shape of the pillars were all critical factors that determine the orientation of the back plate of the handle. For maximum load bearing capability in the pillars, the back piece did not have to be orientated in such a way that the pillars faced the laser. Pillars that faced the laser would be made up of layers that are parallel to the direction of the shear forces to which the handle was subjected and since it was known that the material behaved anisotropic, and was particularly weak in the Z-direction this orientation was not desired. To ensure maximum strength and



flexibility of the snap-fit, the part had to be orientated in such a way that the snap-fit lay parallel to the x y plane. This meant that the direction of bending was perpendicular to the layers, thus ensuring that the snap-fit could not split between the layers, which ultimately resulted in a stronger, more flexible part.

The RM redesign was implemented successfully and, as far as strength considerations were concerned, surpassed its injection-moulded counterpart. In fact the LS part handled the strain so well and with so few breakages that at the time of writing no new orders had been placed for these parts.

### *14.3. ELECTRONIC ENCLOSURE A*

#### 14.3.1. OVERVIEW

The initial product upon which this case study was based was made from sheet metal and not by injection moulding. Although a case study that compared folded metal parts with RM parts cannot shed any light on the relevance of injection moulding DFMs in the RM domain, quite a lot could be gathered that concerned DFRM and DFSL. The aspects that received most attention through the course of this case study concerned part orientation, surface finish, free detail, part reduction and tolerancing on RM parts.

#### 14.3.2. SHEET METAL MANUFACTURING PROCESSES IN PERSPECTIVE

In contrast to both injection moulding and most additive manufacturing processes, where the manufacturing process involved the transformation of material from one phase to another. (I.e. during the SLA process, a photopolymer was transformed from its liquid phase to a solid state. Injection moulding underwent two of these transformations; firstly the plastic pellets were molten and then poured into a mould and left to solidify again.) The process of sheet metal working merely cut and formed

a piece of material into the desired form. The material never changed its phase, and therefore the abilities of this process were limited in a completely different way.

The process of sheet metal bending was in many ways even more restrictive than injection moulding. However, as the properties of the process and the material used in the process necessitated a completely different approach to manufacture, it was not worth the while to go into the details thereof. It was sufficient to say that the process usually involved stamping, drilling, cutting and bending of a ductile metal sheet.

#### 14.3.3. CONVENTIONAL DESIGN

The original design of this electronic enclosure consisted of three different metal parts. The enclosure was depicted in figure 14.4. The first part was a flat rectangular base piece with vertical extensions on two of the four sides that served as clips to attach the cover. One of these extensions formed a guard through which light emitting diodes (LEDs), which were mounted on the printed circuit board, (PCB) protruded. Into this base four threaded mounting bosses were press fitted. These mounting bosses not only served as a means to fasten the PCB to the base, it also acted as spacers to create a gap between the base piece and the PCB. Four additional holes were present in the base through which it was screwed onto a panel.

The cover was a simple rectangular box that clipped onto the base. Apart from the corresponding cut-outs for the LEDs, the only features that were present on this very plain piece were the raised attachment points where it clipped onto the base.

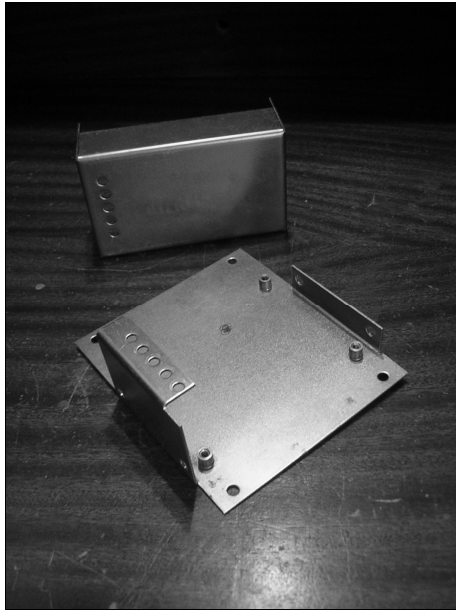

*Figure 14-4: The conventional manufactured sheet metal enclosure*

Although, as far as functionality was concerned, the preferred material for this enclosure was plastic, the customized shape obliterated all hope of purchasing off-the-shelf enclosures and the low production quantities did not justify the manufacture of tooling for injection moulding. Thus, through these external factors the designer was forced to utilize bending processes in order to create a workable part.<sup>7</sup>

#### 14.3.4. OBJECTIVE

The customized design, low production volumes and the preference for plastic parts made this is an ideal scenario for the implementation of RM. If sufficient value could be added to the enclosure through smart design, the high manufacturing cost incurred through RM could become of lesser significance and consequently RM could replace sheet metal bending as the preferred manufacturing process. Accordingly, the new design had not only to give a plastic alternative for the metal parts, it also had to

---

<sup>7</sup> It is not known why the client specifically asked for an investigation of only RM processes and plastic bending processes.

capitalize the unique abilities of RM to add as much value to the product as possible.

This main purpose of the RM redesign was to create a plastic alternative for the current metal parts. The design was specifically required to remain similar. However, since it had to be worthwhile to implement RM, and since it was theoretically possible to add complexity to a RM part without increasing the cost, an attempt was made to add value to the design by improving the aesthetics of the part and to enhance the functionality thereof without deviating from the current design.

An effort was made to limit the amount of post processing and finishing that the part underwent. This was achieved by eliminating the stair-stepping effect that the layer manufacturing process had on the surface finish, through suitable design and part orientation.

#### 14.3.5. RM REDESIGN

The CAD model of the redesigned enclosure was depicted in figures 14-5 and 14-6. Although some major changes were made to the individual parts, the appearance of the assembled product deviated very little from the original design. The RM product still comprised of a rectangular base with five cut-outs for the LEDs and a rectangular box shaped cover. However, the strength properties of the polymeric material used for the construction of the RM part were inferior to those of the metal used for the manufacture of the conventional design. To compensate for this lack of strength the wall thickness of the plastic part had to be increased from 1 mm to 2 mm.

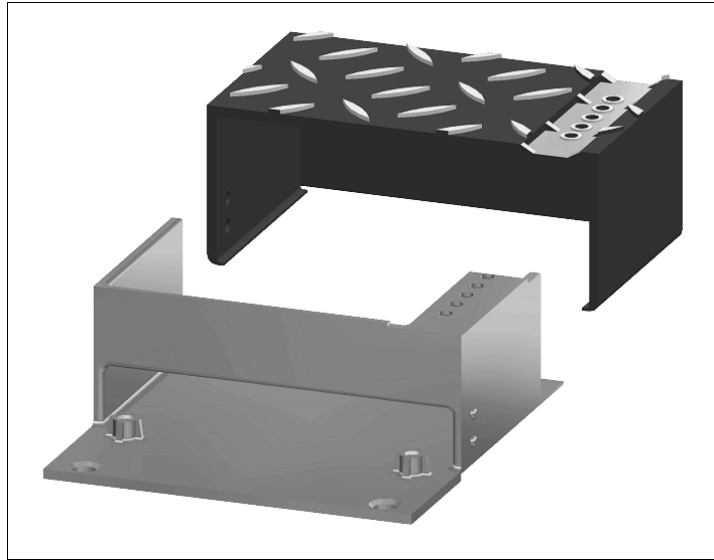

*Figure 14-5: The CAD models of the parts of the redesigned enclosure.*

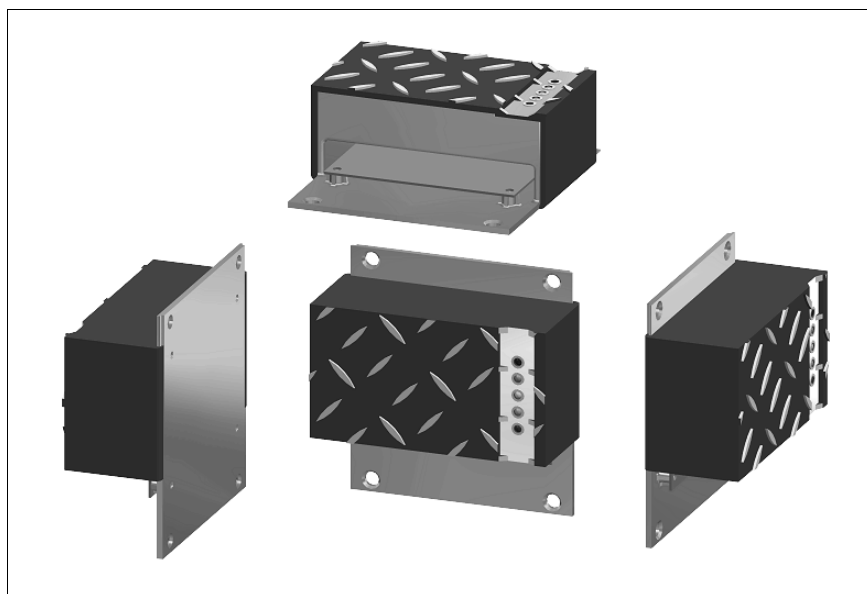

*Figure 14-6: A CAD rendering of the assembled product*

It was possible to press-fit the metal mounting bosses in the RM part similarly to the way that it was done in the conventional design however; every function that these inserts fulfil could be carried out by mounting bosses that were part of the base. Incorporating mounting bosses in this RM redesign was as simple as adding them directly in the CAD model of

the base. Instead of modelling the four hexagonal holes that would have incorporated the inserts in the CAD model of the base, the four mounting bosses were added. In fact, the same exertion required to create the locating holes could also deliver the mounting bosses.

In the same way that the bosses were incorporated in the base, the metric screw thread that was present in the metal inserts could be incorporated inside the mounting bosses. Conventional manufacturing techniques would have required some sort of post processing in order to introduce such internal screw thread; however RM included them by simply modelling them into the CAD model. When incorporating a screw thread such as this that interacted with standard threaded fasteners, care had to be taken to keep the design to the proper pattern. In this case the internal screw thread was designed to interact with commercial M3 screws.

The removal of clotted powder from the inside of such a mounting boss had to be considered. It was easier to remove the powder from a through hole, thus, as in this design, for the sake of powder removal, through holes should be preferred to blind entries.

In the redesigned version the plain rectangular design was lightened up by the addition of small protruding decorative patterns on the top of the cover. Through the implementation of RM it was possible to add logos, slogans, product information or simply detail that improved part aesthetics on every design. Furthermore, the ease with which such detail could be added, removed or altered, made it possible to change the detail on each consecutive part in a production run.

The addition of the extra detail features namely, the mounting bosses with their threaded interiors and the decorative patterns on the top cover did not increase the cost of the RM, but their presence could actually reduce

the overall cost of the product. Significant savings could be contrived by reducing the number of parts in the final assembly and by eliminating post-processing actions. The enhanced aesthetics did not induce savings in the overall production cost, but through this a definite amount of value was added to the product.

The clip mechanism that was used in the metal product was not re-used in the RM product. In stead a sliding mechanism was introduced. As SFF machinery could attain a very high degree of claim accuracy it was necessary to consider the fit of the new sliding mechanism. Under normal circumstances the CAD model would have been drawn up using the nominal dimensions, with tolerances stipulated only on the drawings as guidelines for the manufacturer or machinist. It was then up to him to see that the parts interact with each other in the desired manner. In the case of RM the designer had to make allowance for the fit in the CAD model. If an interference fit was required a certain amount of overlap must be incorporated in the models of the parts. Similarly a clearance fit required a gap. In this instance a H11/c11 loose running clearance fit was desired, of which the magnitude of the tolerances were obtained from ANSI B4-2-1978, R1984 preferred tolerance tables [5].

Throughout the design the build orientation was kept in mind. The holes for the LEDs and the surface finish of the top plane of the cover were important. Accordingly, the cover part was designed to be grown in such a way that the top of the cover was perpendicular to the growth direction. Consequently, most of the part's faces that were not perpendicular to the growth direction were parallel to it. It was anticipated that this orientation should reduce, if not eliminate, the stair-stepping effect caused by the layered nature of the manufacturing process, resulting in a much more acceptable surface finish. Similarly, the critical form on the base was the

holes within the mounting bosses. Thus this part had to be grown so that the mounting bosses protruded parallel to the growth direction.

#### 14.3.6. RESULTS

The laser sintered electronic enclosure was depicted in Figure 14.7. Analysis of the RM parts yielded the following results:

The edges of these rectangular parts were crisp and the surface finish, although not as good as a smooth injection moulded surface, was not unattractive. The presence of the stair-casing effect was very limited.

The protruding aesthetic features that were present on the top surface of the cover had good definition and were clearly visible.

The interface between the screw thread that was grown inside the mounting bosses and commercially available fasteners could be improved. The thread that could be seen within the mounting bosses had fairly poor definition, and accordingly this scanty thread did have some difficulty to accept a commercial grade screw. However, with some patience all four bosses received the fastener.

The sliding mechanism and snap-fit functions were as they were desired.



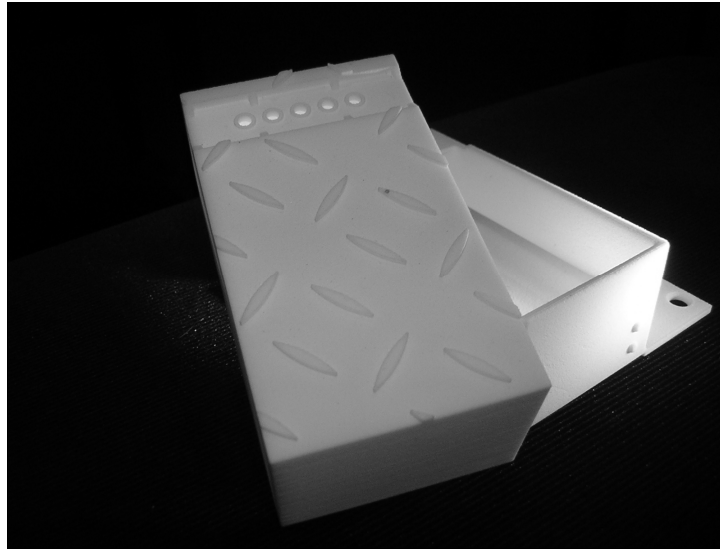

*Figure 14-7: The LS model of electronic enclosure A*

#### 14.3.7. CONCLUSIONS

The DFRM and DFLS guidelines regarding design for surface finish and design for orientation were accurate. It was true that compliance to these specific guidelines severely restricted creative and aesthetically appealing design, but on the other hand, there were numerous occasions where designs with right-angled walls were practical and even desirable.

The crisp lines and good appearance of the protruding aesthetic features that were present on the top surface of the design not only proved that minor details could be added to a design without incurring significant effort and substantial additional costs, it also confronted both the designer and the client with new possibilities in the advertising, product identification and product distinction domains.

The general tolerance specification provided by Bertoline, Wiebe and Miller [5] was utilized to obtain the desired degree of interference between the two parts applied to LS. The characteristically rough surface of LS parts provided ample cause to question the reliability of this tolerancing system in the LS domain, particularly in the clearance fit

region; however the outcome of this experiment, a well functioning sliding fit, indicated that these doubts could be laid to rest. Furthermore, the fact that LS fell in under conventional tolerance specification implied that the general tolerance of LS was within conventional tolerance limits in accordance to the claims made by Mc Mains [36].

#### *14.4. ELECTRONIC ENCLOSURE B*

##### 14.4.1. OVERVIEW

It was a well-known fact that the assembly of products contributed to a very large portion of the overall production cost and significant savings could be contrived by reducing the number of parts in the assembly and by easing the method of assembly. In this case study an attempt was made to add value to a product by smothering these assembly costs through an unconventional approach to the design.

##### 14.4.2. CONVENTIONAL DESIGN

The product upon which this case study was based, consisted of a number of injection moulded parts, electronic components and two printed circuit boards (PCB). With these components two key sub-assemblies were built and fitted together to create the final assembly.

The first sub-assembly that could be identified was the base sub-assembly. To construct this assembly the electrical components and main PCB were inserted into an injection moulded base. Thereafter a minor subassembly, consisting of a PCB carrier and the keypad PCB, was fitted onto mounting bosses in the base, so that it partially covered the electronic components and main PCB. The other key sub-assembly, the frontal cover assembly, was created by inserting a keypad web into the holes in the cover, (Care had to be taken not to insert the keypad upside down) and covering it with a silicon contact pad. Once both these sub-assemblies were completed the cover was turned over and fitted on top of

the base assembly where it was screwed tight. In this final assembly the keypad and silicon pad was sandwiched between the cover and the base and was thus secured in its position.

Chief amongst the assembly problems that arose in this configuration was the fact that the contact pad that covered the keypad web cannot support the weight of the keypad even though it was fitted snugly over an extrusion on the underside of the cover. Thus, the tendency was that the keypad and silicon contact pad fell out when the cover was turned over to be fitted on the base assembly. It was needless to say that this had a negative effect on production line's productivity and that it caused severe irritation.

The fact that the keypad web could be inserted with an incorrect orientation was another matter that required attention. Although this was a minute error that could be mended easily, if the mistake was not rectified immediately, correcting it could encompass the disassembly and reassembly of the entire product, depending on what stage of assembly the blunder was noticed. In spite of the fact that an overturned keypad would not influence the essential functionality of the product, it did not reflect well on the product and the professionalism of the company that was responsible for its manufacture.

Furthermore, the function and use of the PCB carrier was questionable. Although this part does not cause problematic assembly, its redundancy elevated the assembly labour and product cost. It would be preferred if some way could be contrived to eliminate this part.

#### 14.4.3. OBJECTIVE

The objective of this case study was to utilize the unique manufacturing abilities of RM to add value to the product by easing the assembly

process, reducing the number of parts and, reducing the overall assembly time and cost.

#### 14.4.4. RM DESIGN

Although the assembly of the conventional configuration was unnecessarily complex, the final product worked reasonably well. Thus, the functionality of the parts cannot be eliminated and had to be incorporated elsewhere if a part was to be discarded. However, in this particular design most parts fulfilled singular functions; accordingly an attempt was made to redesign the product to include as much of the functionality on as limited amount of parts possible. The base sub-assembly consisted mainly of electronic components and since the idea was not to redesign the entire product, all efforts had to be constricted to the cover and keypad sub-assemblies.

In the current design the process limitations associated with injection moulding constrained the part design so heavily that the parts used to construct the upper assembly could not be reduced. That is, the part count could not be reduced unless the product was completely redesigned. However, by utilizing LS as production method, some major changes could be contrived in the top assembly, not only could the parts in the upper assembly be reduced, but the some of the functionality of parts in the base assembly were incorporated.

The PCB carrier gave support to the keypad PCB and kept it in the correct position. However, this support for the keypad was not necessary since the strength of the PCB was in itself sufficient to withstand all reasonable use and abuse. The positioning function that the PCB carrier fulfilled on the other hand was necessary. Therefore, if an alternative way to position the PCB could be introduced, the part could be discarded.

It was possible to capitalize on the ability of LS to produce extremely complex parts by fusing the functionality of the keypad carrier into the front cover. This could be done by the relatively simple procedure of adding snap hooks to the main cover so that it held the PCB in place. The novelty that lay in this was that the undercuts that were required by the snap-hooks could not be moulded, unless it was done with extremely expensive tooling or by disfiguring the face of the product and jeopardizing the impermeable integrity of the part.

Additionally, implementation of LS as manufacturing process made it possible to incorporate the keypad web within the front cover. The function of any keypad was to transmit translational movement; therefore the keys had to be able to move. To combine the stationary front cover and the non-fixed keys of the keypad into a single part of homogeneous material required a liberal approach. In the end it was contrived by mounting the buttons on springs that in their turn were connected to the cover. Figure 14.8 was a sectional view through the front cover that showed the spring-mounted keys.

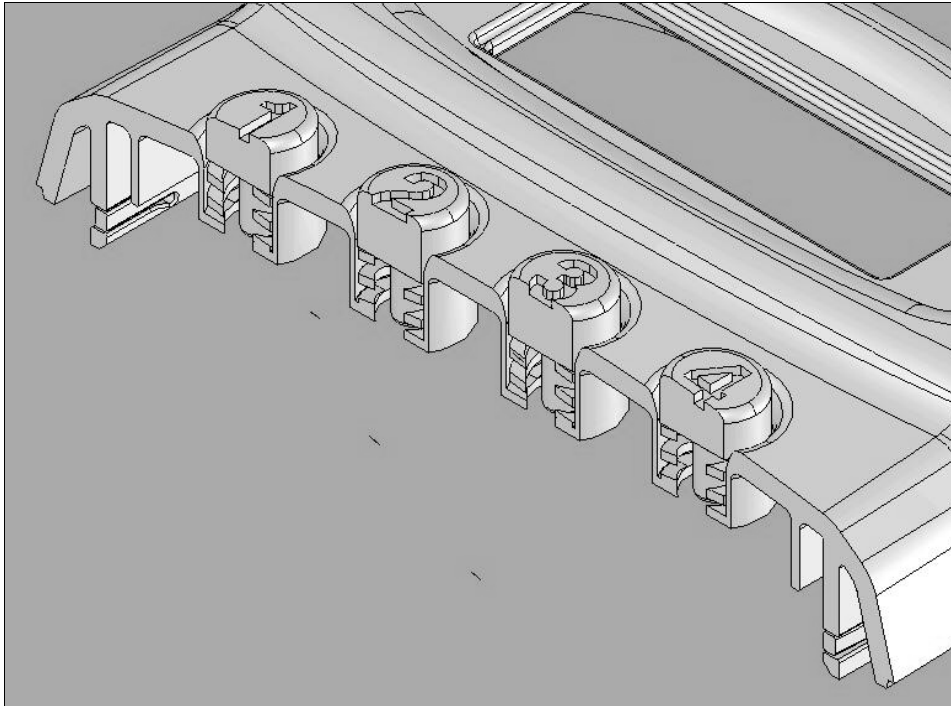

*Figure 14-8: Spring mounted keypad and undercut snap-hooks*

The allowable force and maximum travel that was applied during keypad operation was stipulated as 200g or 1.962 Newton and 1 mm, hence it was necessary to evaluate the physical properties of these keypad springs in order to ensure that it performed as desired. The complete results of the analysis were available in Appendix A. Figure 14.9 showed the finalized spring key design. Notice all the undercuts. To produce this design when it was incorporated into the cover by means of injection moulding was impossible.

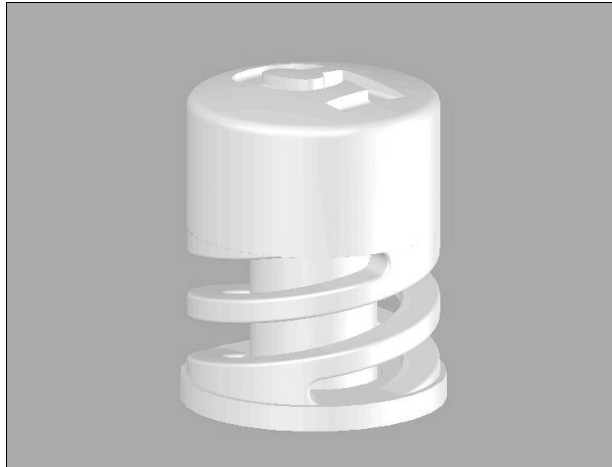

*Figure 14-9: A spring-mounted key*

It was not often the case that such a detail analysis was required for an injection moulded part. The wide range of polymeric material and the restrictive DFM guidelines usually limited part analysis to a few simple calculations. LS designs, on the other hand, were not limited by the complexity of the product. Designers that designed for RM could enhance a design with multifaceted functionality or optimise it for a specific task. It was therefore expected that the tendency to do detail analysis, such as this one, would increase dramatically when designers began to exploit RM to the full.

The silicon contact pad fitted between the keypad web and the keypad PCB fulfilled three functions that could not be reproduced by a LS counterpart. In the first place it carried the carbon conductor pads that formed the interface between the mechanical movement of the keys and the electronic circuits. It was possible to add the conductive contact pads directly onto the laser sintered part but not without the time consuming and labour intensive post processing that made such an action futile. Secondly, this silicon pad was responsible for the positive feedback click that was felt when the buttons on the keypad were pressed. The material restrictions that were currently imposed on LS did not lend itself towards a design that could imitate this click, although the possibility that it could

become possible through the production of non-homogeneous material in the near future could not be ruled out. Thirdly this silicon pad acted as a seal that prevented moisture and dirt to penetrate the enclosure through the gaps between the enclosure and the keys.

Although it was possible to encapsulate the geometric properties of this silicon pad in a LS part, the limited range of materials that were available to use with LS could not replicate the silicon's material properties, hence the presence of the silicon contact pad in the assembly had to be tolerated.

The front view of this design required the highest definition and detail therefore it was imperative that the part was built with the front cover facing the laser squarely. The text on the keypad, shape of the keypad's cylindrical cut-outs, mechanical properties of the keypad springs and definition of the LCD window cut-out, were key in the discerning of this orientation.

This orientation greatly affected the design of the snap hooks that hold the keypad PCB in place since it effectively stipulated their bending direction. In accordance with this stipulated build orientation the snap-hooks were designed to operate in a plane parallel to the face of the enclosure instead of the more obvious choice, perpendicular thereto. The anisotropic nature of LS material necessitated that another detail analysis be made so that a snap hook could be designed that compromised for the inferior material properties. The completed results of this analysis could be found in Appendix B.

Figure 14.10 shows a CAD representation of the underside of the cover. Notice the orientation of the snap-hooks. Further points of interest were the stress relieving rounds at the base of the snap-hooks and the



additional support across the length of the hooks to ensure that the snap-hooks did not bend or fail when a force was applied to the keypad.

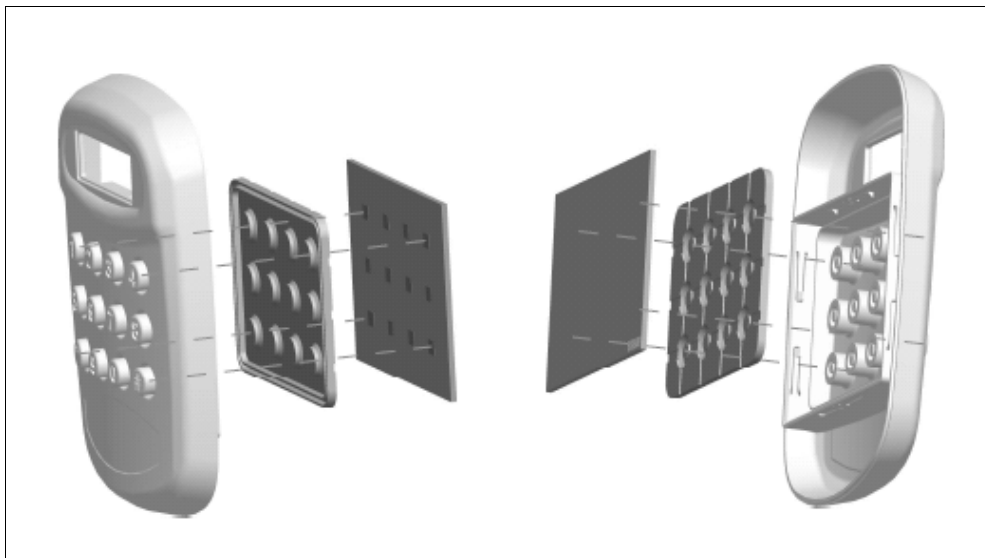

*Figure 14-10: A back view of electronic enclosure B*

In Figures 14.11 and 14.12 further CAD representations were portrayed. Firstly the finalized cover design was shown and secondly the assembly procedure of the product. Figure 14.13 was a picture of the actual manufactured part.



*Figure 14-11: A CAD representation electronic enclosure B*



*Figure 14-12: Two exploded views of the electronic enclosure B assembly.*



*Figure 14-13: The actual RM model of electronic enclosure B*

Through this RM redesign the number of parts that were required for this assembly were reduced significantly and the assembling technique was simplified. The problems that existed due to the presence of the keypad had been addressed and the redundant parts had been eliminated. All these factors undoubtedly added value to the product, but since the number of units required was fairly large, it was doubtful whether these savings were enough to offset the additional manufacturing cost incurred by RM.

#### 14.4.5. RESULTS AND CONCLUSIONS

The approach toward this design was unconventional right from the start. No attempt was made to stick to any injection moulding guideline. The only guidelines that were adhered to were the LS guidelines. In certain instances it did seem as if injection moulding guidelines were followed; however, this was incidental or for other practical reasons i.e. the uniform

wall thickness of the part was due to the part strength that was required and not to avoid pitfalls in the moulding process.

In order to allow the moving parts (the keypad and the snap hooks) that were incorporated in this design to function optimally, the effort had to be made to analyse their physical properties and to adjust the design accordingly. The resulting snap-fits and spring-mounted keypad buttons functioned without any trouble and actually improved as the last bits of excess powder was worked out between the surfaces. During the ordinary design process of plastic parts, a very limited amount of time, if any, was spent on the detail analysis of the mechanical characteristics of the part. Usually the injection moulding requirements direct the design of a plastic part in such a way that the space for optimisation was limited if it existed at all. However, as the tendency utilized RM for production increased and the pressure to produce parts escalated, in depth analysis and part optimisation could increase production through leaner designs.

Because of the ability of LS to manufacture exceptionally complex parts it was relatively easy to design single parts that fulfilled multiple functions. This ability of LS should always be kept in mind, as it was a simple way to add value to the product and compensate for the additional expenditure of the LS parts.

The anisotropic material properties of the LS material had to be kept in mind wherever load-bearing features was designed. The required part strength and orientation of the load bearing features often forced the design into a definite direction.

A definite amount of value was added to the product through the simplification of the assembly procedure. However, the cost incurred by the manufacturing process countered all the advantages gained through the

freeform design and consequently did not make this a viable option in the mass production environment.

When a design was made for RM it was essential that the CAD design was absolutely perfect to the very last detail. To create such a high definition CAD model is a time consuming process and it often was the case that the bottleneck of the RM product development process formed on this level.

From the fact that the silicon contact pad could not be replaced by an LS counterpart, it could be concluded that LS was not an omnipotent manufacturing process. Although LS did have abilities that are remarkable, in certain fields, such as the diversity of manufacturing material as this case indicated, it was clearly outclassed.

In spite of the fact that the part was grown in an orientation that would ensure maximal definition for the text on the keypad, this numbering does not appear very crisp. This manifestation can be attributed to the presence of numerous redundant lines that formed on the slightly curved surface of the keys due to the stair-casing effect. It was therefore recommended that in order to obtain the highest possible definition for any detail feature that detail feature and the surrounding surface had to face the laser squarely.

The snap-hooks and keypad springs functioned as desired through numerous assembly and disassembly cycles and countless keypad operations. It can therefore be safely concluded that the LS material acted in the manner that was anticipated and hence that the tenacity experiment was correct and that it was worth while to consider the orientation of a snap hook during a design for LS.

Although the crude stair-casing that are present on the face of the model was in this instance unattractive, it was possible to mould a design around it in such a way that the stair-stepped surface became an aesthetic feature.

#### *14.5. CHINESE SOUTH POINTING DEVICE*

##### 14.5.1. OVERVIEW AND OBJECTIVES

Around about 2600 B.C. the emperor of China navigated by means of a device called a south pointing chariot. Such a chariot was nothing other than a mechanical compass. The mechanism worked by yielding an output of no angular displacement regardless of what the input displacement received from the two individual turning wheels was. This meant that the pointing figure could be placed in any direction, which would be maintained regardless of how the chariot wheels were turned. Figure 14.14 showed a model of a south pointing chariot.

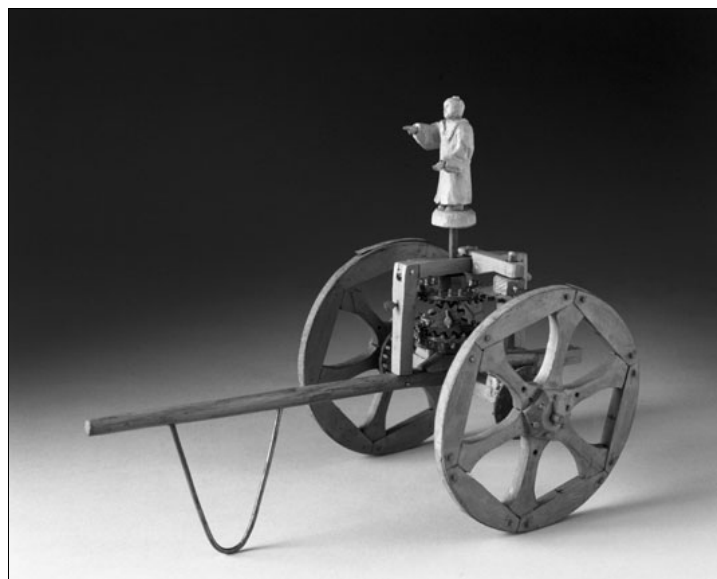

*Figure 14-14: A reproduction of a south pointing chariot*

It was a marvel that people who faced the severe limitations in materials and executable geometric forms, who had no algebra as we know it to couple algebraic sign and sense of relative rotation and who did not have

the concept of zero nor an equal sign, conceived such a design. This engineering triumph, that had baffled many a fine mind through the millennia, was rendered obsolete by the invention of the magnetic compass, of which the first evidence of its existence was obtained from a Chinese record that was dated around A.D. 1080.

The south pointing device was hauled into the twenty-first century and used in this case study firstly, to point out how extensive the ability of LS to produce fully assembled working products was. Secondly, the rapid manufacture of this three thousand year old design added substance and authority to the prediction of Dr. Phil Dickens regarding digital distributive manufacture [33].

#### 14.5.2. CONVENTIONAL DESIGN

Through the years this historical south pointing chariot was invented, re-invented and redesigned a number of times. Consequently, there existed a number of different solutions for this problem. For this discussion it was not the functionality of the mechanism that was important, but rather the logic behind the design and manufacture thereof. Accordingly, a few notes followed with regards to the process that was involved to place one of these south pointing chariots on the table or in the stable.

The three stage design and manufacture strategy that was discussed in section 2.3 was applied to this case. The first step in any ideation phase was always problem identification. In this case the problem statement was relatively simple – create a device that will constantly point in one direction regardless of its orientation. Rephrased in scientific notation that was - design a device that consistently gave zero output regardless of the input. The next step was to conceive concepts for such a device and eventually came up with a preliminary design. This preliminary design was a high order design that did not go into the detail of each part but rather dealt with the physics that made the system function optimally.

Once the logic and physics that drove the south pointing chariot had been set in order and the concept design was considered feasible, the refinement stage began. A detailed design could now be made of each part. When the designs of all the gears, axles, wheels and other parts that were required in the device, had been concluded the parts had to be incorporated in an abstract assembly. In other words, the designer had to plan how all the different parts were to be fitted together and what mechanisms or fasteners would be employed to keep them in place. Furthermore, all design issues that arose during this assembly planning stage had to be dealt with. It was often the case that these issues necessitated the designer to reconsider the part design and sometimes even the concept, but once these were sorted out the designed parts continued to the manufacturing stage where each part was manufactured individually and all were finally assembled to create the final working mechanism. Throughout this refinement stage, calculations and drawings were powerful tools that could be utilized to help the designer visualize and perfect the design. These design drawings could also be used to instruct the manufacturer when the parts and the final assembly was manufactured. Once the design was completed some prototyping and testing could be done, after which the implementation phase commenced.

During the implementation phase the manufacture of the south pointing chariot took place. This happened in accordance to the process stipulated during the design. This described route for creating a physical model could be similar to the route that the first Chinese inventor of a south pointing chariot had followed, although during his design process a limited amount of time would have been spent on mathematical detail design.



In the twenty-first century it was possible to procure standard parts, and thus large portions of detail design actions could often be left out of a design process. Where detail design in the past consisted of the complete design and drawing of every part, it was at the time of writing possible for a detail design to be limited to a few calculations that indicated or specified what parts had to be selected. Although the availability of standard parts rendered large portions of the detail design irrelevant, the abstract assembly stage was still required. The same issues of fitting all parts in the available space and keeping them together had to be addressed. On this point it had to be mentioned that the arrival of CAD software and especially 3D CAD software had made the processes of part design, abstract assembly design, and the creation of part and assembly drawings much less problematic. Once the design was finalized the standard parts could be procured, the required non-standard parts manufactured, and finally all parts assembled into the product.

In this specific design of the south pointing mechanism, standard parts that could be readily procured could be used throughout the design, excepting the undercarriage axles and wheels. Accordingly, apart from the conceptual design and the effort to specify the length of a few axles, very little design work was needed. Similarly, the number of drawings that were required was nearly limited to the assembly drawings. Limited time was spent on the first manufacturing stage where the individual parts were traditionally produced since most of them could be bought or ordered. The final assembly of the parts to create the completed product however, had to occur.

#### 14.5.3. RM DESIGN

As in any conventional product development process the RM product design cycle began with problem identification. In fact the whole ideation process of the RM and conventional product development cycle was exactly similar. The only difference being that the design freedom that

RM offered had to be taken into account during the preliminary design stage.

Since the two processes were so very much similar it was not surprising that it was possible to re-use the conventional mechanical design in the RM model of the south pointing device. The same twelve-gear system that was referred to in the discussion of the conventional design was used again.

It was during the refinement and implementation stage of the development that the major impact of RM can be felt. Although the higher level RM design was similar to the high level conventional design, the way that the components interact with each other on a lower level differed substantially and a number of changes had to be made here.

The first part of this RM detail design stage was characterised by detail calculations, not unlike those carried out in the conventional cycle, which enabled the designer to specify the critical characteristics of each component. With these critical specifications in hand it was possible to obtain the parts from the manufacturer catalogue.

Conventionally, a designer using a CAD system had to design non-standard parts manually and reverse-modelled standard parts from catalogue drawings. All these part models could then be combined in a CAD model that normally gave a good representation of the final manufactured product. A detail analysis of the CAD model could be made but when it came to obtaining the standard parts that were incorporated in the design, these had to be ordered.

However, armed with the calculations done in the detail design stage of the RM south pointing chariot, it was possible to select all the gearing and

bearings that were incorporated in the design from manufacturer's catalogues that were published on the internet. The parts that were selected all had downloadable CAD data available on the internet. Downloading CAD files of standard parts, not only saved time by eliminating the need to reverse model those parts, it also enabled the designer to create a perfect and highly detailed abstract assembly of the final product with only a very limited amount of low level part modelling work that had to be done.

As RM could produce the whole of the assembled product in one manufacturing step, it was imperative to spend time analysing the CAD assembly thereof. In this case more time was spent in assuring that the CAD assembly model was correct than on the actual part modelling. It was very important to see to it that there was no interference between parts and that the standard parts performed in the desired way. Tolerances between parts were essential.

The fact that the total product was manufactured in one piece had a further repercussion on the way that the parts were fastened to each other. In a conventional design nuts, bolts, wedges, keys and press fits had to be used to keep all the individual parts in position. In this RM design none of those joining mechanisms were necessary since it was possible to design the product in such a way that all the parts were grown in the correct position and fixed at all relevant points.

Once the CAD model was completed, the final step of the RM product development process was to send this model to the LS machine for production. In the RM process the prototyping and final production process merged so that the first working prototype was essentially also the first production part.

It was worth noting that throughout the entire design process it was never necessary to create one drawing of the design. The whole design model resided in a computer and only transformed into a physical model once the manufacturing was started.

The following figure was a CAD rendering of the RM redesigned south pointing chariot. Notice the absence of fasteners that kept the various parts in place. Also note the open faces of the bearings that allowed for uncomplicated powder removal.

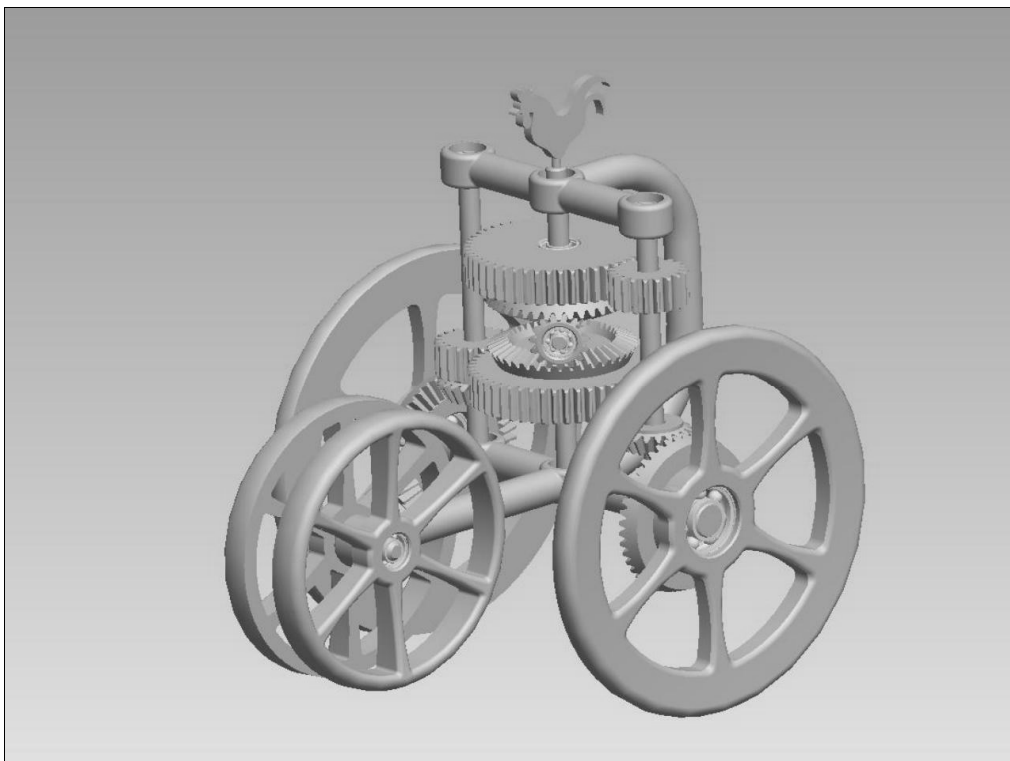
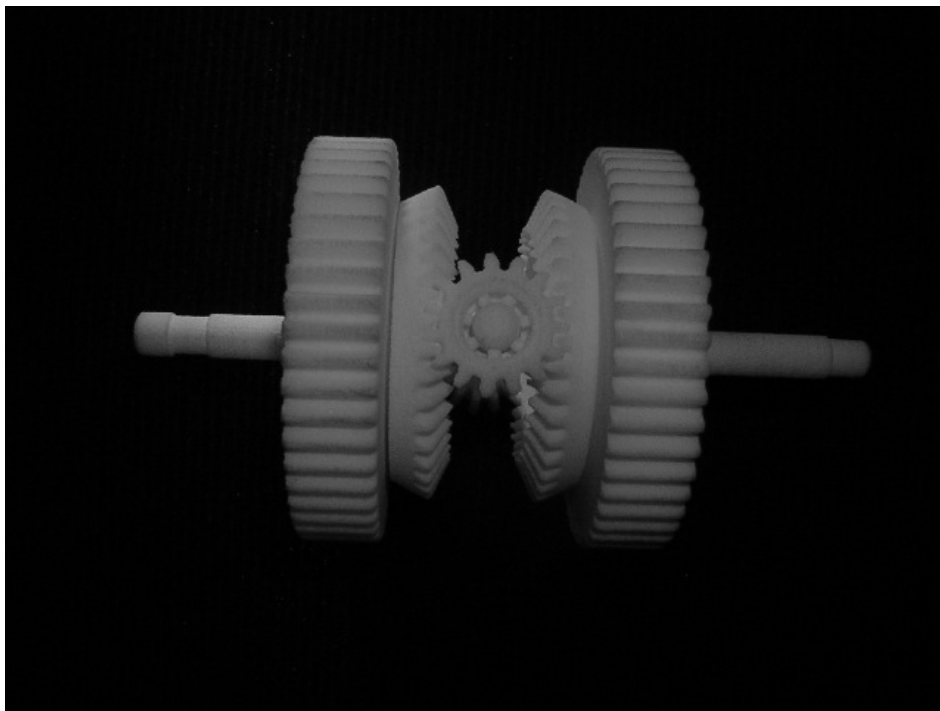

*Figure 14-15: The CAD model of the RM south pointing chariot*

#### 14.5.4. RM OF THE SOUTH POINTING DEVICE

The manufacturer insisted on growing the differential gearing system as an experimental run before the complete model was manufactured. A picture of this model was depicted in figure 14.16. This trial run plainly indicated that the design was somewhat above the current capability of

LS, for although the gearing came out splendidly; stair-casing reduced the small roller balls of the bearings to vague representations of the spheres in the CAD file. Furthermore the minute tolerance between the bearing's interfacing surfaces caused both the inner and outer ring of the bearing to fuse with the rollers. This implied that there was a definite limit to the level of detail and size of parts that could be constructed by means of LS.



*Figure 14-16: The first model of the differential gearing system*

Accordingly the design of the south pointing device was reconsidered. The ball bearings that caused the problems were eliminated and an alternative method was employed to hold the various parts in place whilst allowing them to rotate freely.

The main focus of the design was to increase the clearance between the various moving parts in order to ensure that they did not fuse together

during the LS manufacturing process. The clearance was increased from 0.1 mm to 0.2 mm.

During this revision of the design, the aspect of powder removal required a significant amount of attention. In the previous design the bearings created interfaces between moving parts from which excess powder could easily be removed. The new design did not cater for powder removal in such a simple manner. As a bearing did not create a solid, impenetrable obstruction, it was possible to reach into the cavity behind it to remove powder. The bushing system that was used in the redesigned assembly on the other hand, did create a solid obstruction and this made powder removal difficult. To circumvent this problem, hollow shafts were used with numerous cut-outs through both the shafts and the bushes. Furthermore an effort was made to place interfaces between moving parts in positions that were accessible.

Although the hollow shafts and bushings were incorporated in the design to replace the smaller bearings of the previous design, the large bearings that function as the wheel bearings for the rear wheels were re-used. Unfortunately the bearings could not be used exactly the way that they were downloaded from the Internet. Some manipulation of the CAD file was required before a workable bearing was obtained. This modification included a reduction of the roller's diameter - the gap between the rollers and the inner and outer rings had to be increased - and accordingly, to compensate for the space created by the reduction, extra rollers had to be added into the bearing assembly

A second trial run was made where the wheel bearing and the differential gearing were manufactured. Both assemblies were manufactured successfully and subsequently the manufacture of the complete south

pointing device assembly was authorized. These models were portrayed in figures 14.17 and 14.18.

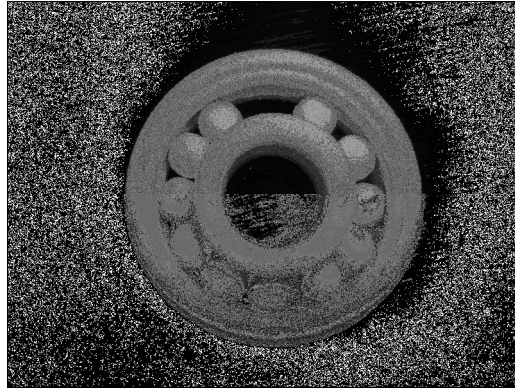

*Figure 14-17: The RM model of the wheel bearing*

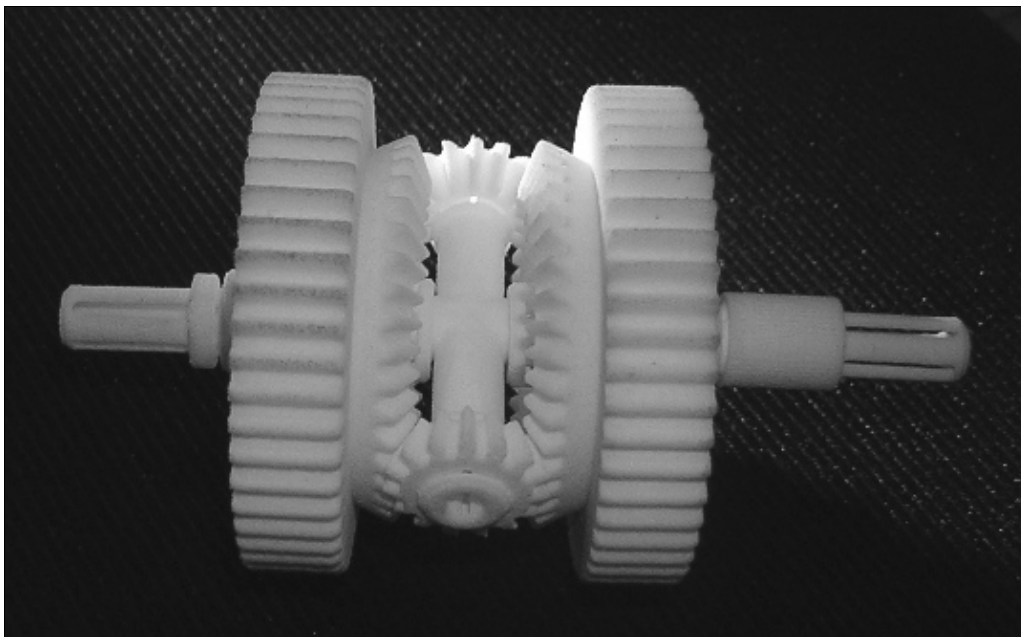

*Figure 14-18: The revised differential gearing system*

Eventually the complete south pointing device was manufactured successfully. A photograph of this RM model was depicted in figure 14.19. The functioning of the gearing system and the bushes were quite

satisfactory, however the relatively loose tolerance of the wheel bearings caused the bevel gears associated with the wheels to slip occasionally.

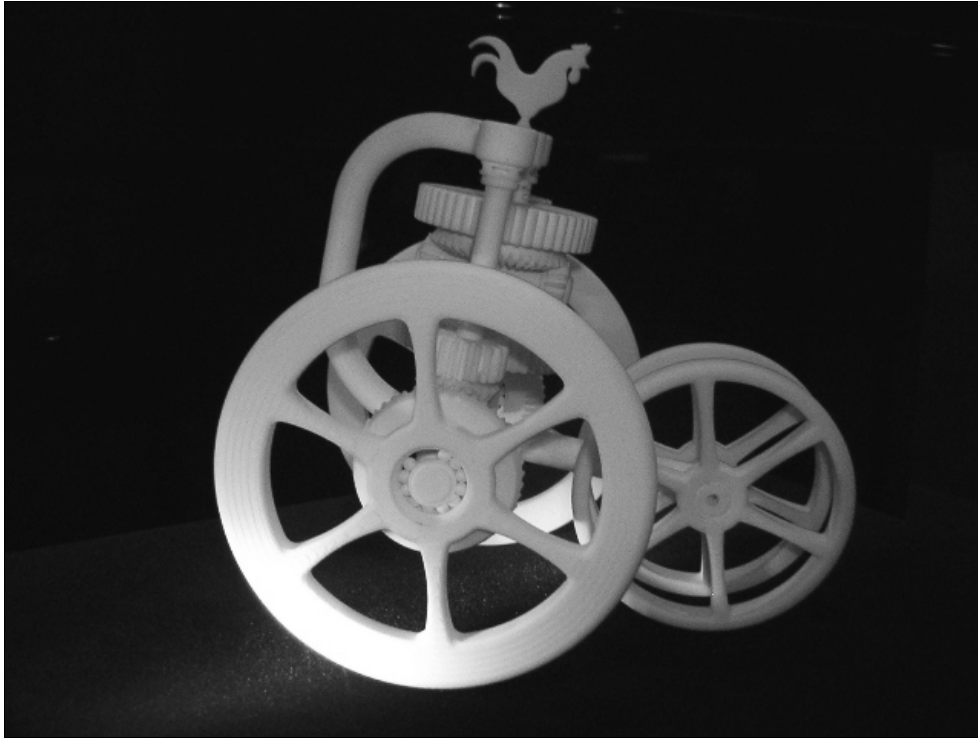

*Figure 14-19: The complete RM south pointing device*

#### 14.5.5. RESULTS AND CONCLUSIONS

In spite of the fact that all the bearings were not produced successfully, the downloaded gears interacted very well, thus proving that digital distributive manufacturing was in fact possible and no longer a dream out of a Star Wars film but, an undeniable reality.

The way that parts interacted with each other in RM assemblies was strikingly different from the way that it interacted in any conventional assembly. RM required no fasteners and no press fits or any similar fastening method. Therefore completely different “out of the box” assembly strategies could be employed to keep parts in their various positions.



It was imperative to design the assembly in such a way that the excess powder could be removed from the finished part without hindrance. To create enough space for efficient powder removal, the various parts in a design could be streamlined and modified to such an extent that they offer the most room that was possible whilst still fulfilling their structural, load bearing and other functional roles. Careful analysis and design optimisation could play an important role in such a “design for breakout” process. In such a scenario finite element analysis software could be a very useful tool. As the rapid production of LS parts increase, the necessity of a fast, hassle free powder removal and breakout process on each and every part could become a very important aspect of DFSL.

This case study indicated that there was a limit to the size of parts that could be manufactured by LS. When a part was produced that was smaller than this minimum it lost its definition. This minimum size of LS parts should be analysed and clearly defined.

Similarly, there was also a limit to the clearance that could be left between moving parts. If the clearance between parts was smaller than this minimum clearance the parts fused. (In this design an estimated minimum clearance of 0.2 mm was assumed.) This minimum clearance should be properly pinned down and included in the DFSL guidelines.

Care should be taken to incorporate the minimum clearance into the tolerance structure of a design. The summation of minimum clearances in a certain direction could result in an assembly with overly lax tolerances. For this reason it was advisable to limit the number of interfacing planes in a linear progression and to refrain from designing RM assemblies when the minimum clearance constituted overly large tolerances in the design.

In spite of the fact that the stair-casing was definitely present on the south pointing device, the nature of the design did not accentuate it and thus for the largest part this defect went almost unnoticed. Recalling the case study of the second electronic enclosure to mind where the stair-casing was strikingly obvious and by comparing the difference between the designs it was concluded that, the stair-casing effect could be downplayed, not eliminated, by designing parts without large clean surfaces. Parts that had smaller broken surfaces tended to “hide” the stair-casing effect and consequently reduced the negative result that it had on the overall aesthetics of the product.

#### *14.6. CHAPTER SUMMARY*

Numerous aspects regarding claims that were made during the literature study and regarding DFRM and DFSL were proved in this chapter, most of which was summed up in the conclusions at the end of each case study; however a number of these results were so substantial that it will be highlighted here once again.

The preceding case studies proved that:

- Conventional DFM, and specifically DFM for injection moulding, could in some cases overemphasise the manufacturability of parts at the cost of their functionality.
- Conventional design for injection moulding parameters that existed due to material constraints could often be transferred to the DFSL arena.
- LS designs had to be moulded around build orientation to facilitate surface finish, accuracy and material strength.
- Powder removal and breakout was not a trivial aspect of LS designs and always had to be taken into account.
- Lavish detail could be bestowed on LS parts as this detail was incorporated with very little fuss and at a very limited cost;

however a definite limit to this detail was set by the surface finish and accuracy of the process.

- Up to a point the accuracy of LS parts agreed with general tolerance specifications.
- Part analysis and optimisation could become a necessity in LS designs as the anisotropic material properties may often require that the strength in different areas of the same part have to be verified in different manners.
- The design freedom offered by LS made it relatively easy to consolidate various parts into a single item.
- CAD does indeed became the bottleneck in the RM product development process and trivial CAD issues became magnified, as CAD models had to be impeccable before any manufacturing could take place.
- LS was not an omnipotent manufacturing process. Definite boundaries of the LS process were encountered in some of the case studies.
- It was proved that digital distributive manufacture was indeed possible.
- The RM product development process that was derived in the literature study was correct. It was proved time and again that RM can produce parts without any requirements for tooling or detailed drawings.
- Living assemblies could indeed be produced by LS.
- RM and living assemblies could change the way in which individual parts were connected to each other in an assembly.

## CHAPTER XV

### 15. CONCLUSIONS AND RECOMMENDATIONS

#### *15.1. CHAPTER OBJECTIVES*

This chapter provided a short summary of some of the most important aspects that had been covered during this research project and the conclusions that were drawn from the work. Furthermore, a section was provided where facets that could present interesting or productive research topics, that were encountered through the course of this project, but could unfortunately not have been investigated, were listed.

Thus, the objectives of this final chapter were:

- To summarize the most important conclusions that was drawn from this research project.
- To provide a record of topics related to this research that was uncovered or touched upon but not investigated.

#### *15.2. CONCLUSIONS*

The first and most important conclusion that was drawn from this dissertation was that any RM process and more specifically LS did have limitations and was not an omnipotent manufacturing process. Although the abilities of RM were revolutionary and the new possibilities that it created were staggering, expectations of RM should never be blown out of perspective. Unfounded expectations regarding RM inevitably lead to disappointment which in turn lead to negative reaction to the manufacturing tool. RM typically performed strong in certain aspects that were definite weak points of injection moulding. This did not make RM superior to injection moulding, it merely emphasised the fact that there was a place for RM as a recognised manufacturing process and that RM

could compliment the range of manufacturing processes in a designer or engineer's toolbox.

Not all conventional DFM guidelines could be rejected summarily when designing for RM. A significant number of conventional DFM guidelines were relevant in the RM manufacturing domain. High order DFM guidelines were applicable to RM processes across the board. In general, DFM guidelines that were driven by material properties could be carried over into the RM domain as long as the material that was used in the RM process was similar to that employed by the conventional process. Conventional DFM guidelines that were process specific tended to become redundant.

There were a number of "soft" DFRM guidelines that were specifically aimed to make a designer attend to the fact that he or she was dealing with a non-conventional manufacturing process and that a non-conventional approach to the design problem could have been beneficial if optimal results were to be obtained from the manufacturing process.

The case studies that were conducted indicated that the general approach toward the design of RM products, the DFRM and the DFSL guidelines were all correct. The essence of the DFRM and DFSL checklists that were developed were acceptable, however were by no means complete. Thorough testing, vigorous experimentation and implementation in proper RM designs were essential to verify and expand all aspects of the checklists.

A fresh, "out of the box" approach toward any design had to be cultivated where RM parts were designed. It was very often possible to design RM parts that could surpass their conventionally manufactured counterparts in surprising ways. Accordingly, RM designers should never have been

content to copy conventional designs, but had to constantly seek new ways to exploit SFF technology and to outperform conventional standards.

The case studies indicated that RM designs focused more on the functionality of a design than on the manufacturability thereof. Points on the DFRM checklist that dealt with aspects such as powder removal and laser drawing time encouraged designers to cut everything out of a design except the absolute necessities. This had to lead to the rise of a tendency amongst designers to incorporate detail analysis and part optimisation techniques as part of their design process.

It was found that RM parts could generally be manufactured within conventional tolerance standards, but as the size of the parts decreased the rough surface finish and stair stepped faces had a more and more pronounced effect that eventually caused the parts to become non-compliant.

The anisotropic properties that the material produced by LS exhibited always had to be kept in mind when designing load-bearing parts. However, although this property of the material could in some cases hinder the design, it also held the potential to become an exciting field of design that had hereto been untitled.

Laser sintering's ability to produce living assemblies could add value to products through the significant amounts of time and money that could be saved due to the reduction of product assembly time. Furthermore this ability opened new doors in the design and manufacturing environment. One such a door could involve the revolutionary manner in which the parts in such a living assembly connected and interacted with each other.

Both the concepts of RM and digital distributed manufacture were tested and successfully implemented during this research project. This decisively proved that both concepts were no longer a dream in a science fiction film but an undeniable reality.

### *15.3. RECOMMENDATIONS FOR FURTHER WORK*

The DFRM structure that was developed in this dissertation was supposed to be one of the first stepping stones on the way to an extensive and thorough DFRM structure. Accordingly, all aspects of this structure required more testing, better verification and further analysis; however a few areas could be identified that, at the time of writing, required more attention than others.

First amongst these were the material properties of the various LS material. Such a study should not only include the optimal properties of data but should also give an indication of the variables that can have an effect on them and how these variables can be manipulated to create a part with material properties that are tailor made for its specific function. Without a thorough understanding of the way that these materials reacted under strain, efforts to optimise and orientate a design was more a matter of guesswork than engineering. Proper material data and an understanding of how variables can be manipulated to produce differing results, would create confidence amongst designers, thus luring them to utilize RM more and more often.

The anisotropic properties of LS material could be studied. Specific emphasis could be placed on how these materials are created and on determining uses for multi-dimensional materials.

The point where the ratio of part size over required tolerance did no longer comply with a similar relationship derived from conventional

tolerance standards had to be determined and the effect that the rough surface finish and stair-stepped surfaces had on classic clearance fits had to be analysed.

Although LS produced very precise and very fine detail, there was a definite point where detail became overly fine. This point where detail features lost their definition or merged with surrounding features had to be examined and definite DFSL guidelines had to be developed so that designers could know exactly to what extent they could exploit this facet of design in the LS domain.

The effect that post build-process mechanical notch introduction had on the material strength of a part had to be thoroughly investigated and the findings of such a study had to be incorporated into the DFRM structure.



## 16. BIBLIOGRAPHY

1. 3D Systems home page, Available at: <http://www.3dsystems.com> (3D Systems company), Accessed June 15<sup>th</sup> 2006
2. Assembly techniques – Category I Screws, press-fit, snap-fit, Available at: [http://plastics.dupont.com/plastics/pdflit/europe/design/L12565\\_9.pdf](http://plastics.dupont.com/plastics/pdflit/europe/design/L12565_9.pdf), Accessed September 27<sup>th</sup> 2006
3. Aquilano, N. J., Jacobs, F. R., Chase, R. B., Operations management for competitive advantage, tenth edition, McGraw-Hill, 2004
4. Basic training EOSsint 360 EOS
5. Bertoline, G. R., Wiebe, E. N., Miller, C. L., Fundamentals of graphics communication, McGraw-Hill, Second edition, 1998
6. Blanchard, B. S., Fabrycky, W. J., Systems engineering and analysis, third edition, Prentice Hall, 1997
7. Bolur,. P.C., A guide to plastics injection moulding, Available at: <http://pcbolur.tripod.com>, Accessed September 25<sup>th</sup> 2006
8. Castle Island's worldwide guide to rapid prototyping, Rapid manufacturing; What RP will be when it grows up... Advantages and disadvantages, Available at: [http://home.att.net/~castleisland/rm\\_11.htm](http://home.att.net/~castleisland/rm_11.htm), Accessed July 12<sup>th</sup> 2005
9. Castle Island's worldwide guide to rapid prototyping, Rapid manufacturing; What RP will be when it grows up...Challenges, barriers

and research directions, Available at:

[http://home.att.net/~castleisland/rm\\_50.htm](http://home.att.net/~castleisland/rm_50.htm), Accessed October 10<sup>th</sup> 2006

10. Castle Island's worldwide guide to rapid prototyping, Rapid manufacturing; What RP will be when it grows up...What are the limitations? Accuracy, Available at:

<http://home.att.net/~castleisland/faq/faq200.htm>, Accessed October 10<sup>th</sup> 2006

11. Castle island's worldwide guide to rapid prototyping, Rapid manufacturing; What RP will be when it grows up...What are the limitations? Accuracy, Available at:

<http://home.att.net/~castleisland/faq/faq212.htm>, Accessed October 10<sup>th</sup> 2006

12. Castle island's worldwide guide to rapid prototyping, Rapid manufacturing; What RP will be when it grows up...What are the limitations? Detail, Available at:

<http://home.att.net/~castleisland/faq/faq220.htm>, Accessed October 10<sup>th</sup> 2006

13. Castle Island's worldwide guide to rapid prototyping, Rapid manufacturing; What RP will be when it grows up...What are the limitations? Materials, Available at:

<http://home.att.net/~castleisland/faq/faq250.htm>, Accessed October 10<sup>th</sup> 2006

14. Castle Island's worldwide guide to rapid prototyping, Selective Laser Sintering, Available at: <http://home.att.net/~castleisland/sls.htm>, Accessed July 22<sup>nd</sup> 2006

15. Castle Island's worldwide guide to rapid prototyping, Selective Laser Sintering brief tutorial, Available at:  
[http://home.att.net/~castleislandrp\\_int1.htm](http://home.att.net/~castleislandrp_int1.htm), Accessed July 12<sup>th</sup> 2005
16. Connolly, J., Direct Rapid Manufacturing - Is it Possible? A look at the many barriers to rapid manufacturing, Time compression technologies, [www.timecompress.com](http://www.timecompress.com), Communication technologies Inc, 2005
17. Design for assembly, Available at: <http://www.teamset.com/design-for-assembly-2.html>, Accessed July 22<sup>nd</sup> 2006
18. Dickens, P., Hague, R., Mansour, S., Saleh, N., Su, Z., Design for Rapid Manufacture, Rapid manufacturing research group, Loughborough University, SME- RPM Conference, 2002
19. Distribution, Available at:  
[http://en.wikipedia.org/wiki/Distribution\\_%28business%29](http://en.wikipedia.org/wiki/Distribution_%28business%29), Accessed September 22<sup>nd</sup> 2006
20. Ferraro-Pollak, S., Marrett, C., Master T., What are the size and shape limitations on the parts?, Available at:  
<http://www.cs.cmu.edu/~rapidproto/students.98/master/project2/sizeshape.html>, Accessed July 22<sup>nd</sup> 2006
21. Ferraro-Pollak, S., Marrett, C., Master T., What material does the process use?, Available at:  
<http://www.cs.cmu.edu/~rapidproto/students.98/master/project2/materials.html>, Accessed July 22<sup>nd</sup> 2006

22. Hague, R., Campbell, I., Dickens, P., Implications on design of rapid manufacturing, Proc. Instn Mech Engrs Vol 217 Part C: J Mechanical Engineering Science, 2002
23. Hague, R., Mansour, S., Salem, N., Design opportunities with rapid manufacturing, Assembly Automation, Vol. 23 Number 4, MCB UP Ltd, 2003, pp 346-356
24. Hague, R., Mansour S, Saleh N, Material and design considerations for Rapid manufacture, International journal of production research, Taylor and Francis LTD, Vol. 42 no.22, 15 November 2004
25. Higgins, R.A., Engineering metallurgy: Part 1 Applied physical metallurgy, sixth edition, Arnold, 1993
26. Hopkinson, N., Dickson, P., Analysis of rapid manufacturing – Using layer manufacturing processes for production, ImechE 2003, Proc. Instn Mech. Engrs, Vol 217 Part C: J. Mechanical Science, 2003
27. Hopkinson, N., Hague, R.J.M., Dickens, P.M., Rapid manufacturing: An industrial revolution for the digital age, John Wiley & Sons, 2006
28. Industrial revolution, Wikipedia, the free encyclopaedia, Available at: [http://en.wikipedia.org/wiki/Industrial\\_Revolution](http://en.wikipedia.org/wiki/Industrial_Revolution), Accessed July 24<sup>th</sup> 2006
29. Injection moulding, Wikipedia, the free encyclopaedia, Available at: [http://en.wikipedia.org/wiki/injection\\_moulding](http://en.wikipedia.org/wiki/injection_moulding), Accessed August 10<sup>th</sup> 2006

30. Jakobsen, K., Andreasen, M. M., The product development process, Training in aluminium application technologies, European Aluminium Association, 1994
31. Kuo T.C., Haung S. H., Zhang H.C. Design for manufacture and design for 'x': concepts, applications and perspectives, Computers and industrial engineering, 2001
32. Lampe, D., The knappers, World and I, volume 06, page 652, February 1991, Available at:  
<http://www.wordandi.com/public/1991/february/cl4.cfm>, Accessed July 27<sup>th</sup> 2006
33. Lawrence, J. R., The Transformation of Manufacturing in the 21st Century, National Academy of engineering, Volume 35, Number 1, 2005. Available at: <http://nae.edu/NAE/bridgecom.nsf/weblinks/MKEZ-6AHJL5?OpenDocument>, Accessed July 21<sup>st</sup> 2006
34. Maniolis Sherman, L., Rapid Prototyping: Pretty soon you would not be able to get along without it, Plastics technology, 2001, Available at: <http://www.ptonline.com/articles/200102fa2.html>, Accessed August 3<sup>rd</sup> 2006
35. Mansour, S., Hague. R., Impact of rapid manufacturing on design for manufacture for injection moulding, ImechE 2003, Proc. Instn Mech. Engrns, Vol 217 Part B: J. Engineering Manufacture, 2003
36. Mc Mains, S., A., under direction of Sequin, C., Rapid prototyping of three dimensional parts, Computer science division, Department of Electrical Engineering and Computer Science, University of California, Berkeley

37. Müller, D. H., Müller, H., Wellbrock, E., Beschreibung ausgewählter Rapid Prototyping Verfahren, BIBA (Bremer Institut für Betriebstechnik und angewandte Arbeitswissenschaft an der Universität Bremen), 2001
38. Prototyping, Available at: <http://en.wikipedia.org/wiki/prototyping>, Accessed September 22<sup>nd</sup> 2006
39. Packaging, Available at: <http://en.wikipedia.org/wiki/Packaging>, Accessed September 22<sup>nd</sup> 2006
40. Rapid prototyping – Advantages and disadvantages, Premier design [http://www.pdmfg.com/processes/rapid\\_prototyping/advantages.htm](http://www.pdmfg.com/processes/rapid_prototyping/advantages.htm), Accessed July 22<sup>nd</sup> 2006
41. Rosato, D. V., Rosato, R. V., Injection moulding handbook, second edition, Chapman & Hall, 1995
42. SANS 527-2, Plastics – Determination of tensile properties, Part Two: Test Conditions for moulding and extrusion plastics, ISBN 0-626-12602-9, edition one, South African bureau of standards, 1993
43. Sauter, V. L., Regot, L., Akers, G., McClendon, C. M., What is prototyping?, 2000, Available at: <http://www.umsl.edu/~sauter/analysis/prototyping/intro.html>, Accessed September 20<sup>th</sup> 2006
44. Schey, J.A., Introduction to Manufacturing Processes, third edition, McGraw- Hill, 2000

45. Selective Laser Sintering, Available at:  
<http://students.bath.ac.uk/en2hlt/SLS2.htm>, Accessed July 22<sup>nd</sup> 2006
46. Selective laser sintering, Available at:  
[http://www.engr.ku.edu/edu/~rhale/ae510/websites\\_f02/SLS/website/](http://www.engr.ku.edu/edu/~rhale/ae510/websites_f02/SLS/website/),  
Accessed August 5<sup>th</sup> 2006
47. Selective Laser Sintering, Accelerated Technologies, Available at:  
<http://www.atirapid.com/tech/sls.html>, Accessed July 14<sup>th</sup> 2005
48. Selective Laser Sintering Process Description, Available at:  
[http://www.atirapid.com/tech/te-sls\\_process.html](http://www.atirapid.com/tech/te-sls_process.html), Accessed July 14<sup>th</sup>  
2005
49. Selective laser sintering, Wikipedia, the free encyclopaedia, Available  
at: [http://en.wikipedia.org/wiki/Selective\\_laser\\_sintering](http://en.wikipedia.org/wiki/Selective_laser_sintering) , Accessed  
August 10<sup>th</sup> 2006
50. Smith, W.F., Principles of materials science and engineering, third  
edition, McGraw-Hill, 1996
51. Stark, J., A few words about DFA and DFM, John Stark and  
Associates, 1998, Available at: [www.johnstark.com](http://www.johnstark.com), Accessed July 14<sup>th</sup>  
2005
52. Stereolithography, Available at:  
<http://students.bath.ac.uk/en2hlt/SLA2.htm>, Accessed July 22<sup>nd</sup> 2006
53. Springs and living hinges,  
[http://plastics.dupont.com/plastics/pdflit/europe/design/L12565\\_6.pdf](http://plastics.dupont.com/plastics/pdflit/europe/design/L12565_6.pdf),  
Accessed September 27<sup>th</sup> 2006

54. Thomson, D.C., The optimisation of part orientation for solid freeform manufacture, University of Texas, 1995
55. UCONN, Solid Freeform Fabrication (SFF) at the University of Connecticut, Available at: [www.ims.uconn/~hmarcus/info.htm](http://www.ims.uconn/~hmarcus/info.htm), Accessed July 15<sup>th</sup> 2007
56. Versadyne LLC, SLA Materials, Available at: <http://www.versadyne.net/Stereolithography/SLA-Material-Page.html>, Accessed July 22<sup>nd</sup> 2006
57. Walker, R., What is plastic injection moulding?, Available at: <http://EzineArticles.com/?Plastic-Injection-Moulding&id=142083>, Accessed March 17<sup>th</sup> 2008
58. Wang, C.Y., Rapid Manufacturing, CSA Hot Topics, 2002, Available at: [www.csa.com/discoveryguides/rapidman/overview](http://www.csa.com/discoveryguides/rapidman/overview), Accessed July 15<sup>th</sup> 2007
59. Wohlers, T., Chrysler compares rapid prototyping systems, Computer-aided engineering, Vol. 11, No. 10, 1992
60. Wohlers, T., Rapid Manufacturing, Computer Graphics World, November 2001, Available at: <http://www.cgw.pennet.com>, Accessed August 12<sup>th</sup> 2006
61. Wohlers, T., Words of wisdom: Rapid manufacturing on the horizon, Plastics machinery and auxiliaries, 2003. Available at: <http://www.pma-magazine/articles/2003/october/4>, Accessed July 12<sup>th</sup> 2005



## APPENDIX A – DETAIL ANALYSIS OF SPRING MOUNTED KEYS

*Table A.1: Governing parameters of spring mounted keypad operation*

<b>Constraints</b>	
Specified load (N)	1.962
Required displacement (mm)	1

*Table A.2: Results of the detail analysis of the spring mounted key design*

<b>Stress Results</b>	
Minimum von Mises Stress (Pa)	168.449
Maximum von Mises Stress (MPa)	26.383
Yield strength (MPa)	31.5
Factor of safety	1.19395
<b>Resultant displacement</b>	
Minimum displacement (mm)	0
Maximum displacement (mm)	1.03352

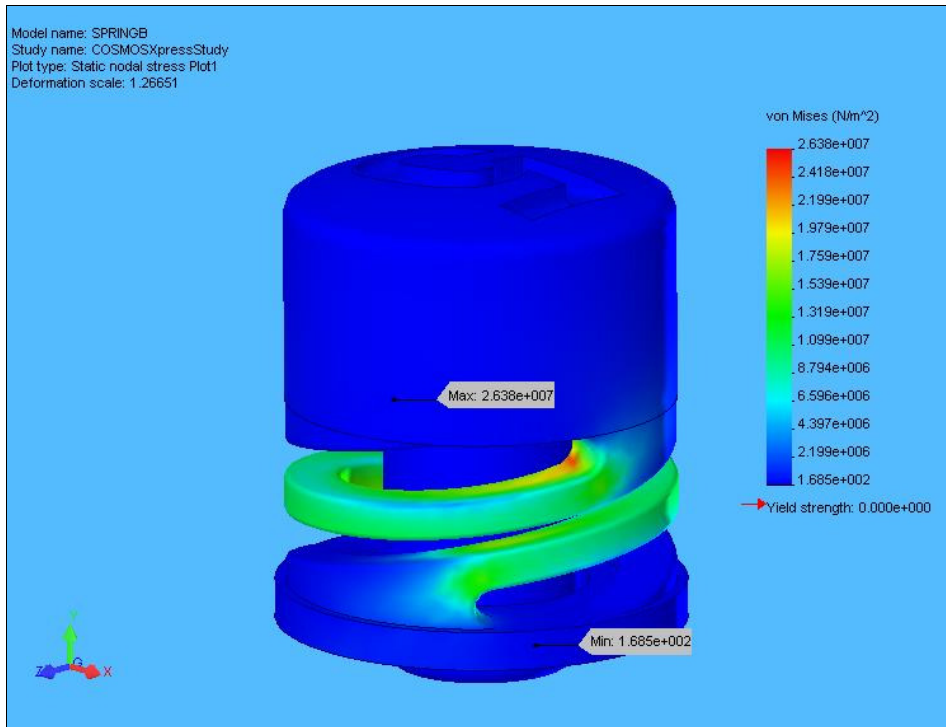

Figure A.1 : Von Mises stress distribution under applied load of 2N

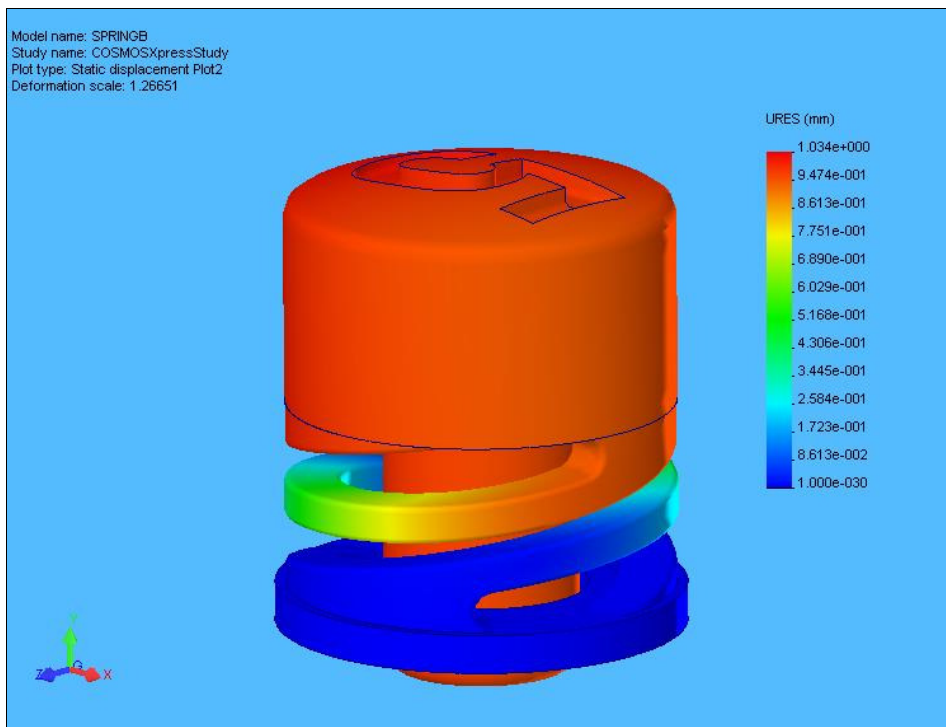

Figure A.2: Key displacement under an applied force of 2N

## APPENDIX B – DETAIL ANALYSIS OF LS SNAP-HOOKS

*Table B.1: Governing parameters of snap-hook operation*

<b>Constraints</b>	
Specified load (N)*	1
Required displacement (mm)	2

\* A 1 Newton force parallel to the bending direction of the snap-hook was applied to each snap-hook. This translated to a total of 8 N or 1.5 kg force that was required to mount the PCB in its correct position.

*Table B.2: Results of the detail analysis of the snap-hook design*

<b>Stress Results</b>	
Minimum von Mises Stress (Pa)	1892.84
Maximum von Mises Stress (MPa)	29.4883
Yield strength (MPa)	31.5
Factor of safety	1.06822
<b>Resultant displacement</b>	
Minimum displacement (mm)	0
Maximum displacement (mm)	2.10166

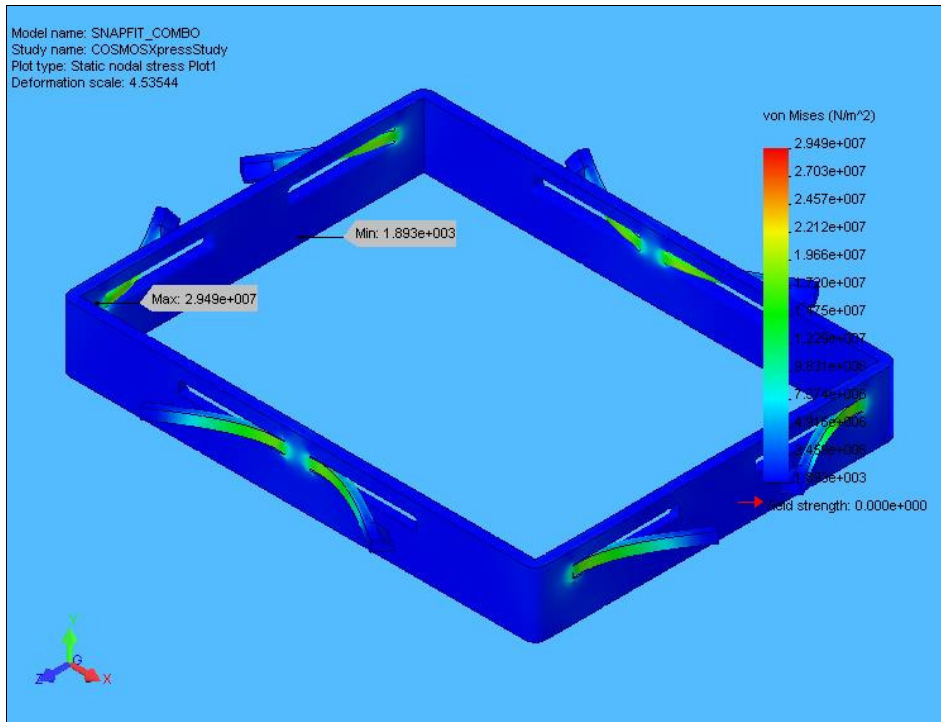

Figure B.1: Von Mises stress distribution under applied load of 1N

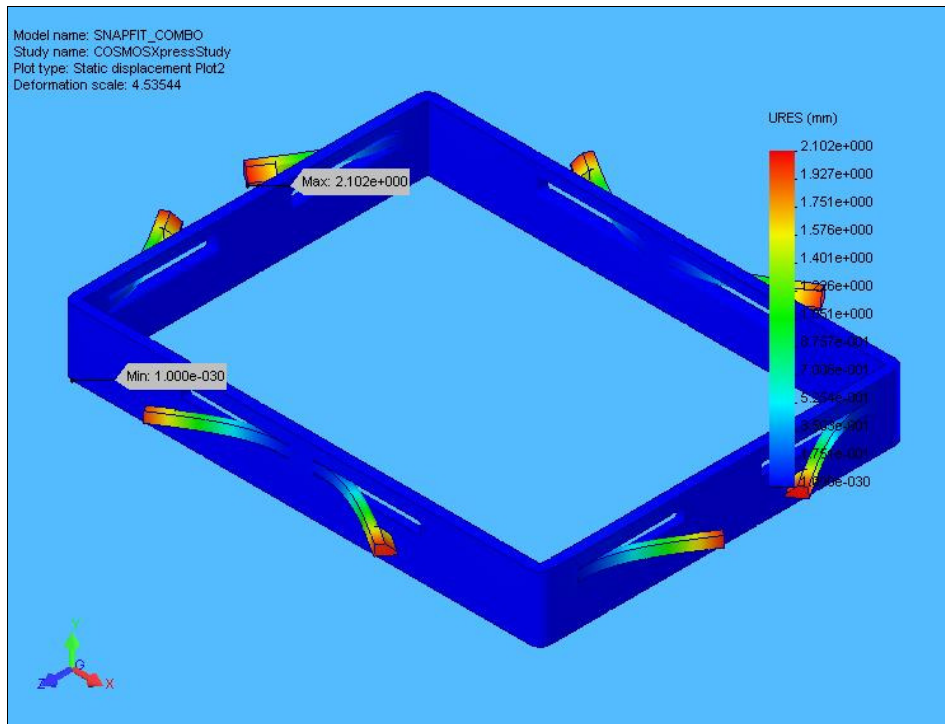

Figure B.2: Snap-hook displacement under an applied force of 1N

## APPENDIX C – JOURNAL ARTICLES

### *C-1. DESIGNING FOR RAPID MANUFACTURE*

The following article has been published in the Journal for new generation sciences, Volume 5, No 1, ISSN1684-4998, 2007

#### **DESIGNING FOR RAPID MANUFACTURE**

G. F. Gerber and L. J. Barnard

Central University of Technology, Free State, Private Bag X20539,  
Bloemfontein, 9300, South Africa

[gfgerber@yahoo.com](mailto:gfgerber@yahoo.com)

#### **Abstract**

The additive nature of rapid manufacture (RM) upsets many fundamental principles of design for manufacture and assembly (DFMA), and can therefore not be applied to aid design for RM (DFRM). The additive nature of RM drives DFRM principles even further apart from conventional DFMA by seeding a series of new possibilities to exploit and new problems to circumnavigate. However, by analysing the differences between conventional manufacture and RM, the influence of true RM on the conventional product development process, and by combining it with the advantages and disadvantages of RM, a series of DFRM guidelines that are applicable to all RM processes can be characterized.

**Keywords:** *Rapid Manufacture, Design for Rapid Manufacture, Solid freeform fabrication*

# 1. INTRODUCTION AND PROBLEM STATEMENT

## *1.1. INTRODUCTION*

In recent years, solid freeform fabrication (SFF) technology has developed to such an extent that the quality of the SFF prototype parts can begin to rival parts that are produced in actual production runs. This has led to the rise of rapid manufacturing (RM), a new manufacturing field where SFF technology is implemented for the manufacture of end-use products.

The fundamental principles of SFF technology carry over to RM. Accordingly, RM technology can be said to be a series of tool-less additive manufacturing processes that can construct parts with geometry that have previously been impractical due to high costs and restrictive manufacturing processes. No tooling compliments the versatility and flexibility of SFF, allowing designers and producers to modify and alter the design of individual parts easily and without any addition to production cost. Unfortunately the inherent drawbacks and limitations of SFF technology are also on hand wherever RM is implemented. Ongoing research and recent developments have resulted in a definite degree of improvement for most RM problems [1] [2]. However in spite of the possibility of even further development, the reality is that some of these problems are more than likely to remain.

Considering the uniqueness of additive manufacture fabrication methods, the outstanding abilities thereof, and the tremendous possibilities that flows from it, it follows logically that in order to harness RM's full potential certain adjustments will have to be made wherever conventional manufacturing processes are replaced by RM systems. Changes caused by implementation of RM will not be limited to the simple substitution of one manufacturing process for another. A radical change of manufacturing

process, such as this, will have a significant impact that will be felt throughout the entire product development cycle, and is prone to transform some long accepted ideas regarding design, production and even distribution and inventory.

### *1.2. PROBLEM STATEMENT*

Unfamiliarity of a designer with aspects, such as the novelty of the RM paradigm, the whole series of new abilities and unique problems associated with RM, which should be considered throughout the design of parts intended specifically for rapid production, will inevitably lead to less than optimal exploitation of RM. Consequently, there is a definite need for the delineation of structured conventions, similar to conventional design for manufacture and assembly guidelines that will indicate how a design problem that incorporates RM as part of the solution should be approached in order to obtain optimal results.

### *1.3. OBJECTIVE*

To establish such a matrix of design for rapid manufacture (DFRM) guidelines, it is necessary to establish what the novel abilities of RM are and what restrictions it impose. Furthermore, an impact study must be done that can ascertain the relevance of existing ideas and principles related to manufacturing in this new manufacturing domain. Guiding principles extracted from this analyses can then be blended together to construct a high order wire-frame of DFM guidelines that will be relevant regardless of the RM process employed and will help graphic designers and engineers conceive designs that are apt for RM across the board.

## 2. CHALLENGING EXISTING MANUFACTURING PARADIGMS AND CONSIDERING NOVEL ABILITIES AND RESTRICTIONS OF RAPID MANUFACTURE

### 2.1. CONVENTIONAL MANUFACTURE VERSUS RAPID MANUFACTURE

There are four fundamental manufacturing processes that are used extensively, in different combinations and sequences, throughout the entire manufacturing industry [3]. These four fundamental processes are:

*Casting or moulding* – Procedures that involves the solidification of liquid material in a special preformed moulds.

*Forming* - Process involving the application of force to reshape, cut or chip, material.

*Machining* - Processes that "cut" specific features into blanks by manipulating a cutting tool's relative position to the work piece.

*Joining* – Actions such as welding, brazing and mechanical assembly of parts.

Accordingly, conventional manufacture can be defined as any manufacturing process that involves any one or any combination of the four fundamental manufacturing processes. Hence, the conventional approach toward design can be defined as a mindset that complies with the rules of manufacturing and design as dictated by the four fundamental manufacturing processes.

Solid freeform fabrication (SFF), on the other hand, is a family of manufacturing technologies that construct parts directly from three-dimensional (3D) computer-aided design (CAD) models, without the need of any tooling, by constructively building them in layers [4] [5] [6]. Intertwined with this unconventional manufacturing technology is a series of novel abilities that is expected to supersede the way that many products



are manufactured [7]. SFF and RM promises to change the way people think about design, manufacturing and product distribution. In fact it is believed that the influence of RM will be so profound that it will cause another industrial revolution which, unlike the first, will enable people to live where they like and produce whatever they need locally [3].

## *2.2. NOVEL ABILITIES OF RAPID MANUFACTURE*

### *2.2.1. GEOMETRIC DESIGN FREEDOM*

As SFF is a tool-less manufacturing process, most of the restrictions that are laid upon designers due to the inability of conventional manufacturing technologies and the need to remove a part from a tool, can be discarded [1] [7] [8]. Without the restriction of removing a product from a tool, designers are free to design any complex geometry that they desire.

### *2.2.2. FREE COMPLEXITY*

Another fundamental advantage of SFF is that the costs incurred for any given additive manufacturing technique are usually determined by the time to build a certain volume of part, which in turn is determined by the orientation in which the component is built. Thus, for a given volume of component, it is effectively possible to obtain the complex geometry for the same tariff as simple geometry of the same size [7] [8] [9]. This is virtually unheard of in conventional manufacturing circles.

### *2.2.3. ADDING VALUE TO PRODUCTS THROUGH INNOVATIVE DESIGN*

Since it RM is able to produce almost any conceivable geometric form and since the cost incurred by increased part complexity is minimal, value can be added to RM parts through inventive design. Additional value can manifest as any combination of a diverse range of features. For example, value can be added to products through enhanced aesthetics, improved functionality, reduced assembly cost or by the addition of new features to existing products.

Two areas where the impact of SFF's ability to enhance designs will be felt that are particularly interesting are the areas of design optimisation and part consolidation.

Contrary to most other engineering disciplines the approach of analysis and verification to achieve optimisation is not commonly used in the product design arena, as optimised designs will to often prove impractical due to restrictions enforced by conventional manufacturing technology [9]. It is anticipated that, due to the limited restrictions of SFF, this approach of optimisation through analysis can be used much more extensively in product development and product design [9].

An important opportunity arising from the freeform ability of SFF is the potential to consolidate many components into one [9]. Such a reduction of parts in assemblies has tremendous implications, not only for the actual assembly of the components and the consequent cost savings that can be gained, but also for the potential to optimise designs of products for the purpose in mind and not to have to compromise the design for manufacturing and assembly reasons [9].

#### 2.2.4. ABSOLUTE ACCURACY

Most manufacturers of SFF systems quote absolute tolerances for their systems, although the part accuracy is usually a factor of the part size, axis of measurement and material used [11] [3]. However, for most SFF processes accuracy in at least two directions are normally very close to absolute and although tolerances in the other directions are not quite at the same level as those of parts produced by CNC systems, most SFF processes are able to produce parts well within normal tolerance ranges [16] [3]. Accordingly, accuracy of SFF parts, although within normal tolerance ranges, is dependant on direction and process and material specific.

This directional variance in accuracy of SFF parts should be kept in account when designing for RM. Parts can be orientated within the build envelope in such a way that critical dimensions can be produced as accurately as possible. Furthermore this ability to produce near absolute dimensions implies that all limits, fits and other tolerancing that are specified in these particular accurate directions will have to be features that are designed into the RM part itself.

#### 2.2.5. NEW MANUFACTURING PARADIGMS

In the past, restrictions imposed by manufacturing technology based on the fundamental processes have restricted designers to such an extent that they have become accustomed to design relatively simple geometries [7]. RM will facilitate omission of most of these restrictions, accordingly designers will no longer be forced to operate in the field that is constrained by manufacturability; they will be able to design complex shapes and parts that are optimised for functionality. However, it may take some time to unlearn the strict discipline that has been acquired over years of applying manufacturability constraints [10].

RM will change the divide between mechanical and aesthetic design [8]. The ability of industrial designers to create the parts without the need to consider manufacturability issues means that, end-use items can be produced, rather than design briefs that are made manufacturable by mechanical designers [8]. Since these two fields, aesthetic and mechanical design, becomes intertwined, it is likely that the advent of RM will lead to a new breed of multi-skilled designers [6].

#### 2.2.6. DIGITAL DISTRIBUTIVE PRODUCTION

Where SFF technology is implemented as manufacturing processes, true just-in-time (JIT) manufacturing becomes possible [1]. RM will enable producers to step over a number of phases that currently form vital parts of the product development process [4] [1]. The short lead times that will

be required for RM, leads to the possibility of eliminating parts inventory [1]. As a matter of fact, RM holds the potential to decentralise all manufacturing procedures by simply installing systems that would receive CAD data from anywhere in the world and build parts on demand [1] [3]. This distributed digital production can become the antithesis of the production line and can lead to a revolutionary new distribution and sales system [3].

### 2.3. *RESTRICTIONS IMPOSED BY RAPID MANUFACTURING*

#### 2.3.1. SURFACE FINISH, AND BUILD TIMES

Accuracy, surface finish, and build times are aspects of SFF that are often at a disadvantage when compared to other manufacturing processes [12] [13] [10]. Consequently, these issues have received a great amount of attention, and as a result, have seen significant improvement [2] [1]. However, in spite of the improvements, some of these issues are likely to remain. Thus it is important to note the effect that they have on rapid manufactured parts.

The issues of surface finish and build times that plague SFF processes are interrelated [2]. Due to the practice of stacking and bonding multiple cross-sectional layers with finite thickness, which forms the basis of all SFF processes, these processes inherently produce parts that have a stair-stepped effect [2] [14]. The stair-stepping effect can be offset by building with thinner layers, but this will of course reduce the build speed [2].

The only alternative method of improving surface finish is by manipulating the part orientation in the build envelope in such a way that surfaces requiring optimal finish face parallel to the growth direction. In this way a few critical surfaces of the part will be produced with a good surface finish, whilst the other less important surfaces will be stuck with the stair-stepping. Similar manipulation can also reduce build times.

### 2.3.2. MATERIAL RESTRICTIONS

Whilst production of SFF parts in non-homogeneous material and the tremendous opportunities that it offers, is still only theoretical possibilities [13], reality reveals noteworthy problems with RM material. As the quantity of material used at present is very low compared to the volumes required by conventional processes, the production cost is high [7]. Additionally, the variety of materials available for SFF production is limited and as the quantity sold is low, it is difficult to justify development of new materials [7].

Designers often lack confidence in the materials that can be used for RM since SFF parts often fail to match their moulded or machined counterparts in materials and mechanical properties [12] [2] [15]. However, although the properties of SFF material are inferior by comparison, the freeform optimisation ability of SFF technology provides ample space for the designer to create functional parts, provided that the properties of the material are known. Thus in the end, it is probably fair to say that the current limitation in material properties lie in the fact that they are not known sufficiently, rather than that they are second-rate [2].

The effect that the highly directional nature of additive manufactured material have on material properties vary from process to process. Nonetheless, there is normally a distinctive amount of deviation in the mechanical properties that is directly related to differences in build orientation [12]. These differences in directional material properties often, but not always, exceed the normal tolerance range for isotropic materials [12]. An interesting phenomenon that can be seen in SFF produced material, especially when the material behaves decisively anisotropic is that the poorest mechanical properties are generally present parallel to the growth direction [17].

### 3. THE IMPACT OF RAPID MANUFACTURING ON THE PRODUCT DEVELOPMENT PROCESS

During the early stages of the rapid product development process, focus should fall on creativity, outside the box solutions and part functionality, not manufacturability as in the conventional process. An effort should be made to add additional value to parts by following an imaginative approach and applying inventive design.

Later during the product development process the impact of RM will be more severe, leading directly to the exclusion of phases such as generation of detail drawings and manufacture of part specific tooling from the process. RM will also bring about a merge between the prototyping final product testing and production phases. Consequently, RM will be a flexible production process that will be able to manage fluctuating production levels and facilitate changes to designs at any time during the development process. Implementation of RM can lead to a system of distributed digital production where the need of inventory, logistical support, and the whole distribution chain will become redundant. Most noteworthy however, is the impact that RM will have on the design for manufacture (DFM) and design for assembly (DFA) design paradigms.

#### *3.1. THE IMPACT OF RAPID MANUFACTURING ON THE DESIGN FOR MANUFACTURE AND ASSEMBLY*

The high order DFM guidelines, petitioning the use of fewer parts, enhanced functionality per part, development of modular designs, the use of standard components and design for specific manufacturing processes, retain their relevance in the RM field. However, as the specific manufacturing process is new, guidelines that stipulate the capacity of these novel processes are required.

All RM processes are tool-less processes, that does not involve any melting and subsequent solidification within the confines of a tool, nor does it involve the insertion and extraction of tools or the extraction of parts from tools. Consequently all DFM guidelines regarding material flow, tool and part extraction, tool wear, material feed and a considerable list of other aspects that deal with the process specific capabilities and restrictions can be ignored when designing for RM. However the most significant impact of RM will be on the guidelines associated with minimizing complex geometries and features [12]. The part complexity is not important and any complex features produced by CAD can be translated into the final product. This is in marked contrast to conventional manufacturing processes.

The most important DFA guideline, which concerns the reduction of the part count, can easily be achievable by RM since the geometric freedom thereof allows the designer to consolidate parts in ways that have previously been impossible [12]. In theory RM makes it possible to reduce the number of parts in any assembly to only one, though in practice this may not always be feasible, as parts are generally not being used in isolation and their interaction with other components would impose limitations on parts-count [12].

All novel abilities and restrictions of RM have not been mentioned in the preceding paragraphs. Table 3.1 shows an inclusive summary of RM compared to conventional manufacture.

*Table 3-1: A comparison of the abilities of conventional manufacture and rapid manufacture technology*

	<b>Conventional manufacture</b>	<b>Additive manufacture</b>
Design paradigm	Focus on manufacturability	Focus on functionality
Design paradigm	Mechanical and aesthetic design is discernable	Mechanical design and aesthetic design merge
Tooling	Required	Not required
Lead times	Time to design, manufacture tooling and produce end use parts	Time to design and produce parts
Initial capital investment	Required for tooling	No tooling and capital investment
Production flexibility	Limited flexibility due to tooling requirements	Very flexible
Geometric design freedom	Constrained by need for tooling and other manufacturing technology limitations	Near complete
Part complexity	Cost is direct proportionate to complexity	Volume determines cost
Forced design stagnation	Consequence of expensive tooling	No design stagnation
Design optimisation	Not permitted due to manufacturability limitations	Optimisation possible
Part consolidation	Allowed within the boundaries of process capabilities	Part consolidation possible and promoted in as far it complements part functionality



*Table 3.1: A comparison of the abilities of conventional manufacture and rapid manufacture technology (Continued)*

Customisation	Limited customisation. Mass production preferred	Mass customisation allowed
Production and inventory and logistics	Required	Digital distributed production is possible
Availability of material	Material is readily available	Limited number of process specific material
Material properties known	Extensively	Largely unknown
Isotropic/anisotropic behaviour	Isotropic	Isotropic/anisotropic depending on process and material
Non-homogeneous material	Impossible	Theoretically possible
Accuracy	Excellent	Tolerably good. Dependant on build orientation
Surface finish	Excellent	Tolerably good. Dependant on build orientation and design. Post-processing may be required
Throughput rate	Excellent	Tolerably good. Dependant on build orientation and product size

#### 4. DELINEATION OF DESIGN FOR RAPID MANUFACTURE GUIDELINES

Considering all aspects of RM and conventional DFM that have been studied in the preceding paragraphs, it is possible to derive a series of

higher order DFRM guidelines that are applicable to all RM processes. The first five high order DFM guidelines that are described in table 4.1 are relevant for all manufacturing technology, proving that the nature of the paradigm of DFM have not been changed when employed for RM. Following the high order guiding principles is a series of DFRM guidelines that were derived by evaluating the novel abilities and restrictions of RM, the contrast to conventional manufacturing procedure and the impact of RM on the product development process. They are applicable to all additive manufacturing processes regardless of the specific manufacturing procedure.

Table 4-1: Guiding parameters for DFRM

<b>High order design for manufacture guidelines</b>	
	Limit the number of parts
	Design parts with multiple functions
	Make use of modular parts
	Use standard components
	Design for a specific RM process
<b>Design for rapid manufacture guidelines</b>	
Paradigm shifts	Note that additive manufacture is radically different from conventional manufacturing, and that conventional manufacturing principles have become outmoded.
	Note that the unrestrained and even undisciplined application of creativity and initiative can result in practical solutions for RM that can give RM an edge over conventional manufacturing.
	Focus on the functionality of the design and do not let any aspect of manufacturability displace it.
	Aesthetic and mechanical design must be considered simultaneously.
	High levels of customisation are allowed and are easily attained.
	Part cost is determined by volume.
Cost efficiency	Reduce part size.

Table 4.1: Guiding parameters for DFRM

<b>Design for rapid manufacture guidelines</b>	
Design optimisation	Optimisation for functionality is allowed.
	Functionality can be complimented with part complexity as for any given volume complexity is free of charge.
	Minimize volume by optimising designs.
	Minimize build times by optimising designs so that minimal cross-sectional area has to be traced by the laser.
	Incorporate lack of material range through design optimisation.
Accuracy	Maximize accuracy by designing for orientation.
	Include tolerance as a design feature
Surface finish	Eliminate stair-stepping on critical surfaces and optimise surface finish by designing for orientation.
Build times	Minimize build times by orientating parts in such a way that the height parallel to the growth direction is minimal.
	Minimize build times by optimising designs so that the cross-sectional area in the laser path is limited.
Conventional DFM	All process specific conventional DFM guidelines regarding aspects like material flow, part extraction, tool extraction and insertion, tool wear, material feed etc. becomes irrelevant.
	All conventional DFM guidelines that promote minimization of complexity become irrelevant.
	Conventional DFM guidelines imposed by material properties and behaviour can be useful provided that the material is comparable with RM material.

## 5. CONCLUSIONS AND FURTHER WORK

Experimental work has to be done to verify the accuracy and reliability the DFRM guidelines that have been derived from this solely theoretical analysis. However, in spite of the absence of verification and the possible exclusion of unpublicised restrictions and exploitable abilities of RM, it is possible to draw some conclusions from the preceding work.

The first thing that becomes apparent through the analysis is the dissimilar nature of conventional manufacture and RM. RM differs so much from conventional manufacturing process that it necessarily requires a completely different approach toward design and manufacture.

The novel abilities and new paradigm of DFRM, and the implementation of additive production systems does not automatically annul all guiding principles regarding design for conventional manufacture and conventional manufacturing. The advent of the implementation of RM compels designers and manufacturers to reassess current practices to determine which will become futile, which will remain relevant and what new ways of exploitation this new manufacturing system allows.

In the same way that the DFM guidelines of conventional manufacture technology are process specific, the largest portion of DFRM guidelines will have to be focused on specific processes. Accordingly, apart from the limited number of higher order DFRM principles, DFRM will in effect be design for laser sintering (DFLS) or design for stereolithography (DFSLA), etc.

The DFRM guidelines that have been derived will not enable designers to use RM as an omnipotent manufacturing process that will overshadow all conventional manufacturing technology, instead DFRM emphasise the fact that RM, like any other manufacturing process only offer restricted

advantages, however, DFRM will enable designers to circumnavigate the known pitfalls of the technology and thus enable them to harness the full potential of RM.

## 6. BIBILIOGRAPHY

1. Castle Island's worldwide guide to rapid prototyping, Rapid manufacturing; What RP will be when it grows up...Challenges, barriers and research directions, Available at:

[http://home.att.net/~castleisland/rm\\_50.htm](http://home.att.net/~castleisland/rm_50.htm). Accessed 10 October 2006.

2. Castle Island's worldwide guide to rapid prototyping, Rapid manufacturing; What RP will be when it grows up... Advantages and disadvantages, Available at: [http://home.att.net/~castleisland/rm\\_11.htm](http://home.att.net/~castleisland/rm_11.htm).

Accessed 12 July 2005.

3. Castle Island's worldwide guide to rapid prototyping, Rapid manufacturing; What RP will be when it grows up...What are the limitations? Accuracy, Available at:

<http://home.att.net/~castleisland/faq/faq200.htm>. Accessed 10 October 2006

4. Castle Island's worldwide guide to rapid prototyping, Rapid manufacturing; What RP will be when it grows up...What are the limitations? Materials, Available at:

<http://home.att.net/~castleisland/faq/faq250.htm>. Accessed 10 October 2006.

5. Hague, R., Campbell, I., Dickens, P., Implications on design of rapid manufacturing, Proc. Instn Mech Engrs Vol 217 Part C: J Mechanical Engineering Science, 2002

6. Hague, R., Mansour, S., Saleh, N., Design opportunities with rapid manufacturing, Assembly Automation, Vol. 23 Number 4, MCB UP Ltd, 2003, pp 346-356

7. Hague R, Mansour S, Saleh N, Material and design considerations for Rapid manufacture, International Journal of Production Research, Taylor and Francis LTD, Vol. 42 no.22, 15 November 2004
8. Hopkinson, N., Dickson, P., Analysis of rapid manufacturing – Using layer manufacturing processes for production, ImechE 2003, Proc. Instn Mech. Engrs, Vol 217 Part C: J. Mechanical Science, 2003
9. Hopkinson, N., Hague, R.J.M., Dickens, P.M., Rapid manufacturing: An industrial revolution for the digital age, John Wiley & Sons, 2006
10. Lawrence, J. R., The Transformation of Manufacturing in the 21st Century, National Academy of engineering, Volume 35, Number 1, 2005. Available at: <http://nae.edu/NAE/bridgecom.nsf/weblinks/MKEZ-6AHJL5?OpenDocument>. Accessed 21 July 2006.
11. Mc Mains, S., A., under direction of Sequin, C., Rapid prototyping of three dimensional parts, Computer science division, Department of Electrical Engineering and Computer Science, University of California, Berkeley
12. Mansour, S., Hague. R., Impact of rapid manufacturing on design for manufacture for injection moulding, ImechE 2003, Proc. Instn Mech. Engrs, Vol 217 Part B: J. Engineering Manufacture, 2003
13. Müller, D. H., Müller, H., Wellbrock, E., Beschreibung ausgewählter Rapid Prototyping Verfahren, BIBA (Bremer Institut für Betriebstechnik und angewandte Arbeitswissenschaft an der Universität Bremen)



14. Thomson, D.C., The optimization of part orientation for solid freeform manufacture, University of Texas, 1995
  
15. UCONN, Solid Freeform Fabrication (SFF) at the University of Connecticut. Available at: [www.ims.uconn/~hmarcus/info.htm](http://www.ims.uconn/~hmarcus/info.htm). Accessed 15 July 2007.
  
16. Wohlers, T., Chrysler compares rapid prototyping systems, Computer-aided engineering, Vol. 11, No. 10, 1992
  
17. Wohlers, T., Words of wisdom: Rapid manufacturing on the horizon, Plastics machinery and auxiliaries, 2003. Available at: <http://www.pma-magazine/articles/2003/october/4>. Accessed 12 July 2005.

## C-2. DESIGNING FOR LASER SINTERING

The following article has been published in the Journal for new generation sciences, Volume 6, No 2, ISSN1684-4998, 2008

### **DESIGNING FOR LASER SINTERING**

G. F. Gerber and L. J. Barnard

Central University of Technology, Free State, Private Bag X20539,  
Bloemfontein, 9300, South Africa

[gferber@yahoo.com](mailto:gferber@yahoo.com)

#### **Abstract**

Until recently solid freeform fabrication (SFF) technology has been used mostly for production of prototype parts. However, as this technology matures, the initiative of utilizing it for the manufacture of end-use products is establishing itself. As this tendency to use SFF for actual production runs increase, a demand is developing for sets of process specific design for manufacture (DFM) guidelines that will assist designers who are designing parts for manufacture by a specific rapid manufacturing (RM) process. The purpose of this paper is to provide RM designers with such a series of process specific design for manufacture guidelines.

**Keywords:** Rapid Manufacturing, Laser Sintering, Design for manufacture, Design for rapid manufacture, Design for laser sintering.

# 1. INTRODUCTION

## *1.1. INTRODUCTION AND PROBLEM STATEMENT*

Until very recently solid freeform fabrication (SFF) technology has been used almost exclusively for production of prototype parts. However, as this rapid prototyping (RP) technology matures, the initiative of utilizing it for the manufacture of actual end-use products is beginning to establish itself. At present, although rapid manufacturing (RM) has not yet achieved the widespread employment of processes such as injection moulding or sheet metal bending, (in truth it is not likely that it ever will), there is a growing number of applications where it is used effectively and with great success.

SFF technology was until very recently confined to an industry that is essentially tasked with the production of representations of end-use products and not the actual production thereof. Thus, the interest and drive to establish the actual ability of SFF systems, over and above its ability to create satisfactory prototype parts, was very limited. To date, although RM has already been implemented successfully numerous times, documentation that aid designers by stipulating good RM design practice is scarce. Mostly the designers that are responsible for such designs are left to learn from personal success and failures. However, as this tendency to use SFF or RP technology for actual production runs increase, a demand will develop for sets of process specific design for manufacture (DFM) guidelines to assist designers when they are designing parts that are to be produced by specific rapid manufacturing processes.

## *1.2. METHODOLOGY AND OBJECTIVE*

The purpose of this paper is to provide RM designers with a series of basic process specific design guidelines. Although the production process of all SFF processes is fairly unconventional, the material and the use of the end product is comparable with similar products produced by

conventional manufacturing processes. Therefore, it stands to reason that certain DFM guidelines will be applicable in both instances. Analysis of the conventional DFM will give a clear indication as to whether or not DFM guidelines will retain their relevance in the new manufacturing surroundings. Thus, the foundation of this DFM guide will be derived directly from a conventional process specific DFM. This foundation will then be extended by adding guidelines that can be derived from the specific SFF production system's abilities and inabilities. This will create a relatively thorough web of guidelines that will ease the task of a designer and enable him to design RM parts with confidence.

## 2. SELECTION AND ANALYSIS OF REPRESENTATIVE CONVENTIONAL AND RAPID MANUFACTURING PROCESSES

### *2.1. SELECTING A PREDOMINANT RAPID MANUFACTURING PROCESS*

It is anticipated that selective laser sintering (SLS), laser sintering (LS) or stereolithography (SLA), or variants of these processes will develop into the first true RM systems [5], thus it is assumed that design for rapid manufacture (DFRM) guidelines that will be instructive for present and future application need to be derived by inspecting these processes. The fact that LS and SLS are essentially the same process [10], contracts the field further to only two relevant candidates. To select one of these two processes as representative SFF technology upon which to base further DFRM research, several key aspects of LS and SLA will be compared.

SLA is fundamentally limited to photopolymers [12] [6] [9]. Even though the mechanical properties of these materials, especially polyethylene [18], are not far apart from the original material properties [12] [6], this limited range of materials causes the ability of SLA to adapt to new applications to follow suit, locking designers into a narrow range of

applications. LS, on the other hand, is a versatile process that can produce parts in various different materials [10] [15] [12]. Theoretically, the LS process can produce parts from any material powder that can melt [9]. Thus, a virtually endless range of materials is available to LS. This drastically increases the technology's uses and enhances its application flexibility.

As SLA parts are essentially built in liquid, support structures are needed to connect the part to the build platform and support overhanging or unstable features that are produced [10]. Consequently, SLA is more efficient when building solid structures [7]. These support structures hinder design, especially on small and/or complex parts, and limit the capacity of SLA systems to production of a single layer of parts each run.

No support structures are required for LS since overhangs and undercuts are supported by the powderbed [3]. Without the need for support structures, smaller and more complex parts are readily producible. The absence of support structures also mean that it is possible to produce parts in multiple layers loaded on top of one another. This stacking ability of LS allows for parts to be nested into one another. This nesting-ability makes it possible to position parts in the build envelops in such a way that the entire volume can be utilized optimally. Furthermore it also allows LS to produce functional living assemblies.

In SLA systems, all uncured resin left in the container after completion of a build, can be reused [9]. The only material wastage is the liquid material that clings to the part when it is removed from the build chamber [19]. The powder used for LS, however, is not completely recyclable [2]. All powder that is used during the building process is subject to a non-reversible ageing process that is caused by the exposure to high temperatures and leaves powder undeniably damaged so that it has to be refreshed by the addition of new powder prior to reuse. Furthermore,

powder that is close to parts or in areas that have a higher temperature tends to bake together and form lumps. These powder lumps are not reusable and must be discarded. However, by nesting parts into cavities and crevices left in or between surrounding parts, such wastage can be kept to a minimum. Optimal usage of space in a build envelope will be achieved when smaller parts and their associated powder lump is completely enclosed by powder lumps of neighbouring parts, and since the cost of this non-reusable powder lumps have already been accounted for in the price of the larger part, optimal usage of build envelope space in effect means production of the smaller parts free of charge.

Mc Mains conducted tests to determine additive manufacturing processes' ability to create complex, free form geometries [9]. In these tests LS out did SLA in most aspects. SLA'S need for support structures is mainly responsible for this lack of free form modelling ability. The support requirement confines SLA to single parts with limited internal geometry, whereas LS can produce complex internal geometries and even functional assemblies.

Various experiments designed to determine the isotropic/anisotropic behaviour of SLA and LS generated material have been carried out. It was determined that the variance of the material properties of SLA generated solid material did not exceed normal inconsistency, consequently it is concluded that SLA produces broadly isotropic parts and that the build-orientation of the part will have a very limited effect on the mechanical properties thereof [8]. Similar testing of LS material indicated that the material properties are dependant on the growth orientation [8] [17].

Further comparison of the abilities of SLA and LS follows in table 2.1. Consideration of the preceding paragraphs and table 2.1 indicate that LS is the prevailing technology. Although LS falls slightly short on accuracy and surface finish, most other factors are overwhelmingly in LS' favour.

Factors such as LS' ability to produce "free" parts, its astounding ability to manufacture free form models and its diverse material range loads LS with aptitude and potential that outweighs all short comings. LS have already proven its worth in the RP sector and as this industry makes the transition toward RM, it emerges as the premiere technology within the industry.

*Table 2-1: Comparison of the abilities of laser sinter and stereolithography*

	<b>Stereolithography</b>	<b>Laser sintering</b>
Material: Available range	Limited to photopolymers	Theoretically any powdered, sinterable material
Material: Mechanical properties	Limited to due to limited material range	Unlimited
Material: Isotropic behaviour	Anisotropic	Isotropic
Support structures	Required	Not required
Reuse of production material	Completely reusable. Limited wastage	Partially reusable
Production of 'free' parts due to nesting and overlapping	Impossible	Possible
Build speed: Laser tracing speed	Similar to LS	Similar to SLA
Build speed: Productivity	2D building envelope limits number of parts in build platforms and requires loading more often	3D placement of parts in the building envelope enables it to produce more parts with less preprocessing
Post curing	Required	-

*Table 2.1: Comparison of the abilities of laser sinter and stereolithography (Continued)*

Breakout	-	Required
Additional surface finishing	As required	As required
Cooling time	-	Required
Modelling ability: Accuracy	Crisp clear edges	Tolerable. Troubled by thermal changes and laser beam offset
Modelling ability: Surface finish	Good, although flaws can be caused by support removal. Stair-casing is present	Compared to SLA, edges are rougher and resolution poorer
Modelling ability: Complex geometry	Restricted due to required support structures	Restricted by necessity of powder removal

## *2.2. SELECTION OF A REPRESENTATIVE CONVENTIONAL MANUFACTURING PROCESS AND ANALYSIS OF ITS ABILITIES*

The range of polymeric parts that are currently being produced by LS are comparable to products that are manufactured by the injection moulding [8] [4], and since injection moulding is the world's premier thermoplastic manufacturing technology [14] it is fitting that this process should be considered as benchmark for aspiring plastic manufacturing technology.

In the same way that designers have need of a DFM structure when designing for RM, a designer that endeavours to design parts expressly for injection moulding requires a certain degree of familiarity with the behaviour of mouldable plastics and the physical capabilities of the production method. As injection moulding is a mature and established



manufacturing process it is relatively easy to obtain lists of process specific design for injection moulding guidelines such as the one that follows in Table 2.2.

*Table 2-2: Design for injection moulding guidelines [1] [11] [13] [14] [16].*

<b>Designing for injection moulding guidelines</b>	
Wall thickness constraints	Wall thickness should be below 5 mm but above 0.5mm. Preferably around 3 mm to avoid a lessening of mechanical properties due to heavy walls or defects associated with too thin walls.
	Wall thickness should be kept uniform throughout.
	If non-uniform wall thickness is unavoidable, transitions should be gradual to prevent sharp changes in temperature during solidification.
Considering sink marks	Sink marks can be made less apparent by designing parts with constant wall thickness and without large masses of melt at any region in the part.
	If thick areas are required lead gradually into them.
The effect of sharp corners	Sharp corners reduce the impact and tensile strength of a part and should be avoided.
	Stress concentration factor increases as the ratio of the radius to the wall thickness decreases, an $R/T$ ratio of 0.6 is favourable.
	Limited advantage is gained if $R/T > 0.6$ as it does not contribute significantly to strength and cause sinks.
Mould filling	Avoid restricting and obstructing the flow of material.

Table 2.2: Design for injection moulding guidelines (Continued)

<b>Designing for injection moulding guidelines</b>	
Weld lines	Weld lines that form on the far side of a core where the split melt stream reunites, lack the strength properties that exist in areas without weld lines, consequently the allowable working stress of these areas should be reduced by 15% and an effort should be made not to load such areas at all.
Parting line considerations	The parting line must be chosen to minimize the complexity of the mould by avoiding unnecessary undercuts.
	The parting lines can be concealed on thin, inconspicuous edges.
Ejection pin and gate marks	Ejection pin marks and gate marks have a negative effect on aesthetics and must be considered early in design
Taper or draft angle	It is desirable for vertical walls of moulded parts to have an amount of draft to permit easy removal from a mould.
Geometric structural reinforcement	Geometrical structural reinforcement, such as doming, corrugating or ribbing is a practical and economical means of increasing the structural integrity of plastic parts without causing thick sections.
Ribbing	Rib thickness at its base should be equal to half the adjacent wall thickness.
	All ribs should have a minimum of 0.5 ° draft per side and minimum radius of 0.125 mm at the base.
	Multiple, evenly spaced ribs are preferred to large single ribs.

Table 2.2: Design for injection moulding guidelines (Continued)

<b>Designing for injection moulding guidelines</b>	
Undercuts	Undercuts, whether internal or external, should be avoided as far as possible.
	It is often possible to encapsulate the desired design intent without undercutting mould movement; however, in order to conceive such designs, designers should give early consideration to this aspect.
Holes and blind holes	The length of the core and depth of the hole is limited by the ability of the core to withstand the bending forces produced by the flowing plastic without excessive deflection.
	For small blind holes with a minimum dimension below 5 mm the length to diameter ratio should be kept to 2.
	Holes should be located far enough from edges and corners to permit material to weld properly around the pin.
	Whenever it is possible, chamfering should be used on open holes, since it reduces or eliminates the potential for rough moulded corners and cracks.
	Holes that are impractical to mould must be drilled, but they must not be too close to edges or corners, as cracks can result.
	Accuracy of through holes is generally better than blind holes.
Self tapping screws	Self-threading screws can be an economical means of securing separable plastic joints and should be kept in consideration.

*Table 2.2: Design for injection moulding guidelines (Continued)*

<b>Designing for injection moulding guidelines</b>	
<b>Press fits</b>	Check that the maximum developed stress is below the value that will produce creep rapture in the material as there is usually a weld line in the hub that will significantly affect the creep rapture strength of most plastics.
	When designing an interference press fit the addition of crush ribs to the inside diameter of the boss is recommended.
<b>Bosses</b>	The bore of the boss should be deeper than the depth to which the thread will be cut.
	The bore at the entrance of the boss should have a short length with a slightly larger diameter.
	Strong weld joints around screw bosses are essential.

Table 2.2: Design for injection moulding guidelines (Continued)

<b>Designing for injection moulding guidelines</b>	
Plastic thread	External and internal screw threads can be moulded in plastic parts.
	All sharp interior corners must be eliminated.
	The beginning as well as the end of the thread should be rounded off in order to avoid notch effects.
	Coarse threads can be moulded easier than fine ones, thus threads with a pitch smaller than 0.8 mm should be avoided.
	The length of the thread used should be at least 1.5 times the diameter and the section thickness around the hole more than 0.6 times the diameter.
	The thread should be designed to start about 0.8 mm from the end of the face perpendicular to the axis of the thread.
	As engineering plastics generally have better resistance to compressive stresses than to tensile stresses. Therefore threads that are to be coupled with metal components should be made on the outside of the plastic part.

Table 2.2: Design for injection moulding guidelines (Continued)

<b>Designing for injection moulding guidelines</b>	
Cylindrical and spherical snap fits	It is essential to keep the wall thickness constant throughout.
	There should be no stress risers.
	The snap fit must be placed in an area where the undercut section can expand freely.
	The ideal shape for this type of snap-fit is circular.
	Cracks may develop during assembly due to weak spots produced by weld lines, gate marks or voids. If a weld line is the problem and cannot be avoided by changing the overall design or by moving the gate to another location, the section at the weld line can be strengthened by means of a bead or rib.
Snap fits with cantilevered lugs	Cantilevered lugs should be designed so as not to exceed allowable stress during assembly operation.
	To short a bending length may cause breakage.
	Cantilevered lugs should be dimensioned to develop constant stress distribution over their length. This is achieved by providing a slightly tapered section or by adding a rib.
	Special care must be taken to avoid sharp corners and other possible stress concentrations.
	When a fracture of the snap-fit does occur as a result of overloading during the joining operation, the cross section should not be increased, but the hook should be designed to be more flexible.
	On account of the frictional forces and stresses that appear at the point of joining, all angles of joining should be chosen to be no larger than 60°.

*Table 2.2: Design for injection moulding guidelines (Continued)*

<b>Designing for injection moulding guidelines</b>	
Internal hinges	The thickness of the hinge should be approximately equal to the sidewalls of the part.
	Due to the mould fill requirements and the necessary stiffness of the hinge action, the thickness of the web should be around half the wall thickness, but it is not recommended that it should be less than 0.125 mm.
	The length of the web to thickness ratio should be no less than 3 to 1.
	It is vital to ensure that the melt flow during the moulding operation is perpendicular through the hinge (perpendicular to the hinge's bending action) so that its molecules stretch to give a strong, pliable hinging section.

### 3. DELINEATION OF DESIGN FOR LASER SINTERING GUIDELINES

By considering the abilities of LS, and conventional DFM that have been studied in the preceding paragraphs, it is possible to derive a series of lower order, process specific DFRM guidelines. These guidelines are listed in table 3.1. In this case these guidelines are only applicable to LS and can therefore be referred to as design for laser sinter (DFLS) guidelines. Ideally the designer should use these DFLS guidelines in conjunction with general DFRM guidelines that are applicable to RM across the board.

*Table 3-1: Guiding parameters when designing for laser sintering*

<b>Design for laser sinter guidelines</b>	
Breakout	Removal of excess material from the completed part should be considered during the design stages.
	Unless properly supported, intricate and fine external detail should be avoided, since it complicates and slows the breakout procedure and can result in losses due to fracture.
Material properties: Isotropic behaviour	Incorporate anisotropic behaviour of material by optimisation.
Design as assembly	Consolidate parts and design living assemblies if possible.
Corners	Sharp corners should be avoided since it cause stress concentrators that reduce impact and tensile strength.
	A favourable ratio of radius to wall thickness is 0.6 however this can be increased unlimited if desired.
Wall thickness	Contrary to injection moulding guidelines solid shape modelling is allowed although it will increase the build time due to increased laser trace time.
	Wall thickness as little as 0.01 mm can be produced, however, due to material constraints, wall thickness should preferably be similar to injection moulded walls. 2.5 to 3 mm is a good guiding rule.



*Table 3.1: Guiding parameters when designing for laser sintering  
(Continued)*

<b>Design for laser sinter guidelines</b>	
Geometric structural reinforcement	Ribbing and other forms of geometric structural reinforcement can be used to optimise parts but is not mandatory. Since complex geometry can be produced at no extra cost, and as RM materials can in some instances be lacking, this is an ideal way to improve structural integrity of a design.
Ribbing	Multiple, evenly spaced ribs are preferred to large single ribs.
Self tapping screws	Self-threading screws can be an economical means of securing separable plastic joints and should be kept in consideration.
Press fits	Ensure that the maximum developed stress is below the value that will generate creep rapture in the material. Bosses for press fits should be orientated in such a way that will ensure maximum strength of the surrounding solid material. However RM's geometric freedom combined with analytical optimisation can compensate for material weakness.
	When designing an interference press fit the addition of crush ribs to the inside diameter of the boss is recommended.

*Table 3.1: Guiding parameters when designing for laser sintering  
(Continued)*

<b>Design for laser sinter guidelines</b>	
<b>Plastic thread</b>	External and internal screw threads can be produced easily in plastic RM parts.
	All sharp interior corners must be eliminated.
	The beginning as well as the end of the thread should be rounded off in order to avoid notch effects.
	Threads with a pitch smaller than 0.8 mm should be avoided. Coarse threads are preferred to fine ones.
	The length of the thread used should be at least 1.5 times the diameter and the section thickness around the hole more than 0.6 times the diameter.
	The thread should be designed to start about 0.8 mm from the end of the face perpendicular to the axis of the thread.
	RM screw threads should always be designed with part orientation and anisotropic material behaviour in mind. Although the anisotropic behaviour of the material will cause a reduction in strength, the most accurate thread will be attained by orientating the thread to face perpendicular to the growth direction.

*Table 3.1: Guiding parameters when designing for laser sintering  
(Continued)*

<b>Design for laser sinter guidelines</b>	
<b>Bosses</b>	The bore of the boss should be deeper than the depth to which the thread will be cut.
	It is possible to produce bosses with in-designed threads, however as self tapping screws can be used with success, it should be contemplated whether or not this will be worth the effort
	The bore at the entrance of the boss should have a short length with a slightly larger diameter.
	Again it is advised to orientate bosses, like press fits, in such a way that will ensure maximum strength of the surrounding RM generated solid material.
<b>Cylindrical and spherical snap fits</b>	Wall thickness must be kept constant throughout.
	There should be no stress risers.
	The snap fit must be placed in an area where the undercut section can expand freely.
	The ideal shape for this type of snap-fit is circular.
	If cracks develop that cannot be avoided by changing the overall design or orientation of the part, the section where the crack form can be strengthened by means of a bead or rib or other geometrical reinforcement.

*Table 3.1: Guiding parameters when designing for laser sintering  
(Continued)*

<b>Design for laser sinter guidelines</b>	
Snap fits with cantilevered lugs	Cantilevered lugs should be designed so as not to exceed allowable stress during assembly operation. Stress risers should be avoided.
	Too short bending length may cause breakage or malfunction.
	Cantilevered lugs should be designed to develop constant stress distribution over their length. This is achieved by a slightly tapered section or a rib.
	Special care must be taken to avoid sharp corners and other possible stress concentrations.
	If fracture of the lug occurs as a result of overloading during the joining operation, the cross section should not be increased, rather increase the flexibility.
	On account of the frictional forces and stresses that appear at the point of joining, all angles of joining should be chosen to be no larger than 60°.
	The cross sectional orientation of cantilevered lug snap fits should be perpendicular to the growth direction as this will ensure maximum strength and flexibility of the part.

*Table 3.1: Guiding parameters when designing for laser sintering  
(Continued)*

<b>Design for laser sinter guidelines</b>	
<b>Internal hinges</b>	The thickness of a living hinge should be approximately equal to the sidewalls of the part.
	Due to the necessary stiffness of the hinge action, the thickness of the web should be at around half the wall thickness but it is not recommended that it be less than 0.125 mm.
	The length of the web to thickness ratio should be no less than 3 to 1.
	It is vital to ensure that the cross-sectional growth orientation during the building operation is perpendicular to the growth direction (perpendicular to the hinge's bending action) so that entire cross sectional layers can stretch to give a strong, pliable hinging section.

#### 4. CONCLUSIONS AND FURTHER WORK

Most of these DFSL guidelines that are discussed here are derived from literature analysis. Experimental work is therefore necessary to verify the accuracy and relevance thereof, and as SFF technology and RM are manufacturing processes that have not reached maturity, it is expected that the DFSL guidelines should be revised and amended every time a new development or improvement enhance the technology. Accordingly these guidelines should not be treated as a rigid set of rules, but should be updated continuously, especially with the experience gained by the individual designer from his own successes and failures.

In contrast to the common belief that RM will develop to become an all engulfing, omnipotent manufacturing process, the DFSL guidelines is not

a step closer to establishing LS as a supreme manufacturing process, instead the DFSL and DFRM emphasise the fact that LS, like any other manufacturing process only offer restricted advantages. DFSL enables designers to circumnavigate the known pitfalls of the technology and thus place them in a more favourable position to harness the potential of LS.

Although LS is a revolutionary manufacturing process and its abilities are astonishing it does not automatically annul all guiding principles regarding design for conventional manufacture. On the contrary, the implementation of LS as a RM process urges designers to challenge all conventional design practice and sift through them to salvage the aspects that remain relevant in the new manufacturing domain.

## 5. BIBLIOGRAPHY

1. Assembly techniques – Category I Screws, press-fit, snap-fit, Available at: [http://plastics.dupont.com/plastics/pdflit/europe/design/L12565\\_9.pdf](http://plastics.dupont.com/plastics/pdflit/europe/design/L12565_9.pdf), Accessed May 10<sup>th</sup> 2008.
2. Basic training EOSsint 360 EOS
3. Castle Island's worldwide guide to rapid prototyping – Selective Laser Sintering, Available at: <http://home.att.net/~castleisland/sls.htm>, Accessed May 10<sup>th</sup> 2008.
4. Design for assembly, Available at: <http://www.teamset.com/design-for-assembly-2.html>, Accessed May 10<sup>th</sup> 2008.
5. Dickens, P., Hague, R., Mansour, S., Saleh, N., Su, Z., Design for Rapid Manufacture, Rapid manufacturing research group, Loughborough University, SME- RPM Conference,2002
6. Ferraro-Pollak, S., Marrett, C., Master T., Stereolithography materials, Available at: <http://www.cs.cmu.edu/~rapidproto/students.98/master/project2/materials.html>, Accessed May 10<sup>th</sup> 2008.
7. Ferraro-Pollak, S., Marrett, C., Master T., The size and shape of SLA parts, Available at: <http://www.cs.cmu.edu/~rapidproto/students.98/master/project2/sizeshape.html>, May 10<sup>th</sup> 2008.
8. Hague R, Mansour S, Saleh N, Material and design considerations for Rapid manufacture, International journal of production research, Taylor and Francis LTD, Vol. 42 no.22, 15 November 2004

9. Mc Mains, S., A., under direction of Sequin, C., Rapid prototyping of three dimensional parts, Computer science division, Department of Electrical Engineering and Computer Science, University of California, Berkeley
  
10. Mansour, S., Hague. R., Impact of rapid manufacturing on design for manufacture for injection moulding, ImechE 2003, Proc. Instn Mech. Engrs, Vol 217 Part B: J. Engineering Manufacture, 2003
  
11. Plastics part design and moldability, Available at: <http://pcbolor.tripod.com>, Accessed: May 10<sup>th</sup> 2008.
  
12. Rapid prototyping – Advantages and disadvantages, Premier design, Available at: [http://www.pdmfg.com/processes/rapid\\_prototyping/advantages.htm](http://www.pdmfg.com/processes/rapid_prototyping/advantages.htm), Accessed: July 22<sup>nd</sup> 2006
  
13. Rosato, D. V. Rosato, R. V., Injection moulding handbook, second edition, Chapman & Hall, 1995
  
14. Schey J.A., Introduction to Manufacturing Processes, third edition, McGraw- Hill, 2000
  
15. Selective Laser Sintering, Available at: <http://students.bath.ac.uk/en2hlt/SLS2.htm>, Accessed: July 22<sup>nd</sup> 2006
  
16. Springs and living hinges, Available at: [http://plastics.dupont.com/plastics/pdflit/europe/design/L12565\\_6.pdf](http://plastics.dupont.com/plastics/pdflit/europe/design/L12565_6.pdf), Accessed: May 10<sup>th</sup> 2008.



17. Thomson, D.C., The optimization of part orientation for solid freeform manufacture, University of Texas, 1995

18. Versadyne LLC, SLA materials, Available at:  
<http://www.versadyne.net/Stereolithography/SLA-Material-Page.html>,  
Accessed: May 10<sup>th</sup> 2008.

19. Wohlers, T., Chrysler compares rapid prototyping systems, Computer-aided engineering, Vol. 11, No. 10, 1992