

ROVING ON PHOBOS: CHALLENGES OF THE MMX ROVER FOR SPACE ROBOTICS

Jean Bertrand ⁽¹⁾, Simon Tardivel ⁽¹⁾, Frans Ijpelaan ⁽¹⁾, Emile Remeteau ⁽¹⁾, Alex Torres ⁽¹⁾, Stéphane Mary ⁽¹⁾, Maxime Chalon ⁽²⁾, Fabian Buse ⁽²⁾, Thomas Obermeier ⁽²⁾, Michal Smisek ⁽²⁾, Armin Wedler ⁽²⁾, Joseph Reill ⁽²⁾, Markus Grebenstein ⁽²⁾

(1) CNES, 18 avenue Edouard Belin 31401 Toulouse Cedex 9 (France), firstname.lastname@cnes.fr

(2) DLR, Münchener Straße 20 82234 Weßling (Germany), firstname.lastname@dlr.de

ABSTRACT

This paper presents a small rover for exploration mission dedicated to the moons of Mars, Phobos and Deimos. This project is a collaboration between JAXA for the mother spacecraft, and a cooperative contribution of CNES and DLR to provide a rover payload.

This rover will be different in many aspects compared to the existing ones. It will have to drive in a very low gravity with only little power given by the solar arrays. It will also need autonomy in order to achieve a consequent distance during a short mission of 100 days.

Apart of the technology demonstration driven mission aspects, the first objective after landing for the rover is to secure the mother spacecraft landing through a characterization of the soil (regolith). Hence, in the nominal rover definition, several payloads are foreseen in order to contribute to the mission of the main spacecraft: to determine the origin of Martian moons.

1. INTRODUCTION

Small bodies, whether they are asteroids, comets or small planetary satellites, have been the target of several missions in the past decades. Far from quenching our thirst of knowledge, the discoveries made by NEAR-Shoemaker (NASA), Hayabusa 1 and 2 (JAXA) and Rosetta (ESA) have only further bolstered the science community interest in these objects. Most missions now reach the surface, increasing the need of in-situ explorers for soils that are still largely not understood and therefore very risky to land a spacecraft on.

A prime example of such context is the Mars Moons Exploration (MMX) mission from JAXA. MMX would perform a sample return and extensive in-situ study of Phobos [1], the largest natural satellite of Mars. Phobos is a small satellite of irregular shape in a close orbit of Mars. Since 2016, amongst other contributions to the mission, CNES has studied the possibility of sending a small rover to the surface of Phobos. This lightweight rover would be carried by the MMX probe and jettisoned to the surface from a low altitude.

Once on the surface, the rover would deploy and upright itself from its stowed position and orientation, and carry out several science objectives over the course of a few months. In October 2018, CNES and DLR have expressed their interest in partnering together on this project and the MMX rover is now a joint project of both organizations in tight cooperation. After a description of the MMX mission defined by JAXA, this paper presents the Phobos environment. Then, it details the mission constraints and the rover objectives. It outlines some solutions envisioned in the current rover design (end of phase A). The last part tackles the specific robotic challenges set by this small rover in such a hostile world.

2. THE MMX MISSION

The MMX spacecraft should be launched by H3-24L during summer 2024. The interplanetary flight is foreseen to last about 1 year. In the vicinity of Mars, the spacecraft is placed on a Quasi-Satellite-Orbit around Mars/Phobos and uses its remote sensing payload.

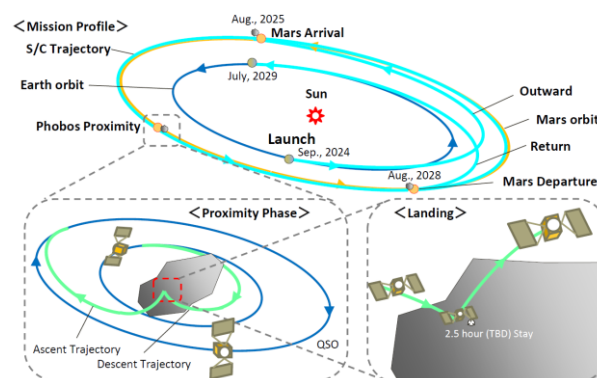

Figure 1. Overview of the MMX mission (credit JAXA)

2.1. JAXA/ISAS Minor body exploration strategy

Realizing that rocky planets should, most probably, have been born dry leads to the key question “How was water delivered to them?” Delivery of water, volatiles, organic compounds etc. from beyond the snow line allowed the rocky planet region to be habitable.

Mars was at the gateway position of the rocky planet region. In the case of MMX, the question then becomes “Are the small bodies around Mars, Phobos and Deimos, remnants of capsules for the delivery of water?”

To answer that question, the first point to address is the origin of the Martian moons. It would allow significant progress in the understanding of planetary system formation and of primordial material transport around the border between the inner-and the outer-part of the early solar system.

Three hypotheses have been formulated to explain the origin of the Martian moons: results of a giant impact, capture of asteroids, or co-formation with Mars. Through remote sensing and sample return, MMX is tasked to reveal which is the most likely.

2.2. Contribution of the rover to JAXA objectives

JAXA has assigned two objectives to the rover:

- Risk mitigation and mission safety: Landing on Phobos poses many dangers to the MMX probe → The rover is a scout, sent out to experiment Phobos first.
- Contributions to scientific objectives: remote sensing and sampling would benefit from the 'ground truth' → The rover is an explorer, performing science in-situ and put the sampling in its context.

The way in which the rover meets these two objectives will be detailed in chapter 5.

2.3. The MMX Spacecraft

MMX Spacecraft is composed of three main modules; Propulsion, Exploration and Return. The target mass is 4000kg (including propellant) with a power of approximately 900W given by solar array. The mission duration is foreseen to last 5 years.



Figure 2. MMX Spacecraft (Credit JAXA)

2.4. Landing Site Selection

As the number of descent operations of the MMX spacecraft is limited by the fuel needed for that, the rover deployment will be carried out during a rehearsal of the spacecraft own landing. The rover will be jettisoned just before the spacecraft escape from the actual landing sequence, it means between 100 and 50 meters from the Phobos surface.

The Landing Site Selection process will be conducted jointly for the MMX Spacecraft and the rover. As the

rover is requested by JAXA to contribute to the mothership landing safety, the rover will be jettisoned on one of the finally selected landing sites. JAXA is foreseen to progressively reduce the number of potential landing sites (from 50 to a few) by imaging from low-orbits and possibly by flybys at even lower altitudes.

On the rover side, the landing site selection has to take into account some specific constraints: terrain configuration at rover scale (slope, obstacles density...), solar energy available (refer to chap. 3.1), RF visibility with MMX spacecraft.

3. PHOBOS ENVIRONEMENT

Phobos is the largest and closest natural satellite of Mars. As seen in Fig. 3, it's 'potato-shaped' (27 x 22 x 18 km). It is a very dark body without atmosphere. It is covered with craters and other prominent geological features, with a surface probably comparable to the Moon.



Figure 3. Phobos by MRO (Credit NASA/JPL)

3.1. Global properties of Phobos

Orbit. Phobos is very close to Mars, at a mean distance of 9375 km, compared to 3394 km radius of Mars, and its prograde rotation is tidally locked, i.e. it always shows the same face to Mars.

Its rotation axis is, within 1°, aligned to that of Mars, and 26.71° to the ecliptic. With an orbital period of only 7.65 hours, it is well within the synchronous orbital distance.

Gravity. Phobos surface acceleration is comprised of gravity but also of Mars tides and the centrifugal acceleration from Phobos' rotation. Hence this surface acceleration should technically be referred to as "effective gravity".

Accounting for a small margin on the estimates due to possible density variations, the surface acceleration on Phobos will range between 0.003 to 0.007 m/s² (approximately 0.3 milli-g to 0.7 milli-g).

Considering the current hypotheses on landing site, for the rover the gravity should be at most 0,5mG. A free fall

from 100m takes 190s, results in 1m/s velocity; it is equivalent to a 5 cm fall on Earth.

Lighting conditions. Using simplified spin and orbital models, we can derive the average power at any geodetic latitude. It is the power received by a surface parallel to the ground (e.g. solar arrays), accounting for the actual path of the sun in the sky, averaged over a whole Phobos day (see Fig. 4).

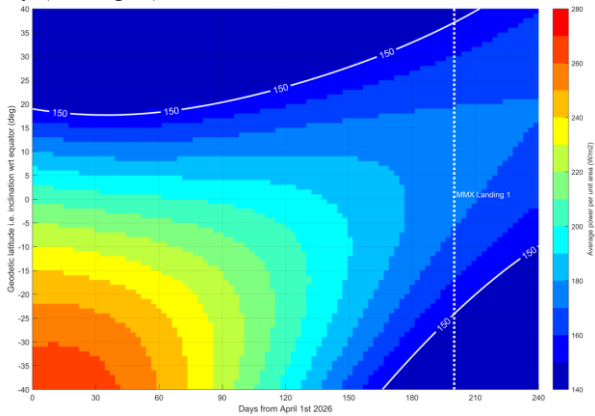

Figure 4. Average power in W/m^2 $f(\text{date}, \text{latitude})$

The white line in Fig. 4 indicate the level of 150 W which is a probable lower limit for survivability considering the solar arrays surface and the minimum temperature requirement inside the rover.

3.2. Topographical environment

Phobos is thought to be covered with some of the impact ejecta of its craters, similarly to the surface of the Moon. The thickness of this top layer is estimated to vary at the surface between 2 to 100m, with an average thickness of 35m. This regolith should be composed of aggregates from micrometers (grains) to a few meters (rocks). Compared to the surfaces of recently visited asteroids (Ryugu and Bennu), Phobos is expected to be quite smooth. At the m scale, it is comparable to the Moon.

3.3. Thermal environment

The incoming flux on Phobos comprises direct solar flux, Mars shine (i.e. solar flux reflected by Mars and thermal emissions by the Martian surface) and self-heating of Phobos (i.e. light and thermal radiation reflected at other areas before arriving at a given point). It might also occur that a given area on Phobos is shadowed by some other part of the surface. Moreover, the Sun is frequently eclipsed by Mars near the equinoxes. There are only a few studies on thermal modelling on Phobos. Since data on thermal parameters are rare, usually for unknown input parameters the corresponding values for Earth' moon were applied and, if necessary, adapted to the conditions on Phobos, e.g. to the smaller gravitational force at the surface.

Parameters	Values
Surface regolith density	Range [1.1, 1.6] g/cm^3
Surface regolith specific heat capacity	Range [158.4, 858.7] $J/(kg K)$
Surface regolith thermal conductivity	Range [2.7*10-5, 3.5*10-3] $W/(m K)$
Temperature at surface	Range: [70, 353] K
Temperature at subsurface below 1 cm	230K (+- 5K over the year and day)

Table 1. Some thermal parameters of Phobos

3.4. Soil properties

The soil of Phobos is largely unknown since it is unobserved. The mechanical behavior of possible soil materials in very low gravity is also largely unknown. The macroscopic soil properties are derived from analysis during flybys and matching of surface features using simulation models.

From the analysis of Mariner 9, Viking 1, 2 and ground-based observations, it was concluded that the surface layer of Phobos consists of fine-grained material (regolith) with a composition close to that of carbonaceous chondrites [3]. Estimates vary, but large areas of Phobos should have a nearly uniform regolith thickness between 5-100m [4].

In fact, direct interaction with actual regolith in the actual gravity is required to understand the regolith mechanical properties and behavior in this system. Thus, thanks to its driving capability, the MMX rover will allow characterizing the regoliths mechanical and dynamical properties in great details.

4. MISSION CONSTRAINTS

The first constraint that applies to the rover project is the overall schedule of the MMX mission.

So, the development of the rover will only last 5 years, starting nearly from scratch. Indeed, even though CNES and DLR have already contributed to studies on rovers for Mars or for the Moon, none have yet worked on a rover for the moon of Mars.

4.1. Mass and volume allocation

The first technical constraint applying to the rover design is the mass and volume allocation given by JAXA:

- Total system mass of the complete system is 29kg including separation mechanism and RF equipment on the spacecraft.
- Dimension of the Rover and the separation mechanism on the spacecraft array are:
 - o length=440 mm
 - o width=520 mm
 - o height=350 mm.

In the current definition, the rover will be placed on the science instruments panel, between the landing gears of the exploration module (see Fig. 2).

4.2. Class of risk

The mission launches in 2024, is short (100 days) and low-cost. This leads us to use as much equipment from the CubeSat world as possible and limit development to adaptations of existing technology.

The Product Assurance plan will consider a Class III project regarding electronic parts selection. Commercial components are allowed and the design robustness will be obtained through a system level hardening philosophy.

4.3. Telecommunication

The rover will implement a low power RF sub-system design for Low Earth Orbit (LEO) CubeSat. Thus the rover has no possibility to communicate directly with Earth. Communications will be relayed by the MMX spacecraft but, due to mission constraints, a direct bent-pipe relay is not possible. Hence, the rover remote control can only be used with time lags from several hours up to several days.

4.4. Radiation

The input hypothesis for radiation constraint calculation are very different compared to usual LEO satellites.

The overall mission of the rover will last two years and half. But in fact, the rover will be turned off almost all this time. During interplanetary cruise and first MMX mission phase consisting of Phobos global mapping, the rover will be turned on from time to time for health checks and battery charge. Thus, the radiation induced single events constraint applies only to the nominal 100 days' mission at Phobos.

Regarding Total Integrated Dose (TID), as the MMX spacecraft considers a direct transfer trajectory, Van Allen belt contribution can be neglected. The environment taken into account is interplanetary, without atmospheric nor magnetosphere shielding, at 1 AU in order to be conservative. But on top of that, a strong 2π steradian solid angle shielding can be considered. Provided by MMX spacecraft prior to separation, then by Phobos itself while the rover is active.

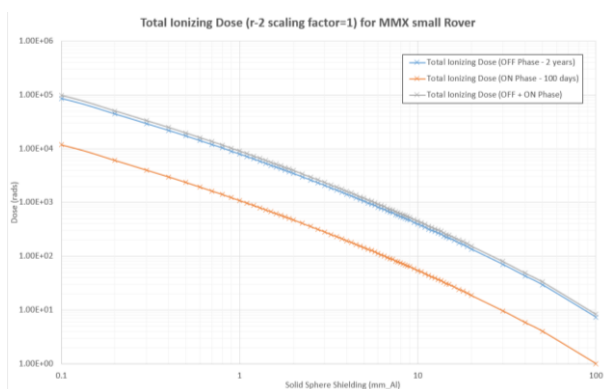

Figure 5. Rover TID function of Al(mm) shielding

Fig. 5 shows the TID curve computed with these hypotheses. A standard assumption of 3mm aluminum (solid sphere) gives a TID of 2.5kRad(Si).

4.5. Planetary protection categorization

The planetary protection issue on the sample return from Martian moons has been discussed for the MMX mission. Even though the rover itself will stay on Phobos, some equipment will stay on the main spacecraft. In this frame, Planetary Protection could be a major constraint applied to the rover overall system.

A first workshop has been held with ESA Planetary Protection Working Group (*Sep. 2018 in London*), then in the COSPAR planetary protection panel (*Jan. 2019 in Vienna*). The final conclusion is to recommend “unrestricted earth return” to MMX’s sampler return mission.

5. ROVER OBJECTIVES

As mentioned in chapter 2.2, JAXA has assigned two high level objectives: landing risk mitigation for the MMX spacecraft and a contribution to the scientific objectives. For CNES and DLR, the rover has also several technological demonstrator ambitions which constitute the real challenge for the robotic.

First, the rover will demonstrate wheeled locomotion in very low gravity. It expands the realm of conditions where wheeled locomotion is understood. Then, the limited telecommunication possibilities and the short duration of the rover mission lead to give as much autonomy as possible to it.

5.1. Mothership landing risk mitigation

The first phase of the rover’s mission will be to assess the risk of landing a spacecraft of a few tons on a largely unknown terrain. JAXA has expressed the risks to mitigate with the rover:

- Turn-over or solar array collision with surface.
- Unexpected sinking of landing pad.
- Regolith contamination.
- Electrical shock.

The three first hazard group can be addressed with the nominal definition of the rover and its payloads.

The rover will use its wheels to disturb regolith and observe it. It also takes high resolution images of (a part of) itself and of the surface. It will measure local inclination of the gravity vector. The mothership could also image the crater of the rover at high resolution.

5.2. Scientific payloads

On the top of technological demonstration of the ability to drive autonomously on a small body, it is foreseen to embed several scientific payloads. The rover possesses two front cameras on a stereo bench used both for navigation purpose and for science.

It has also two ventral cameras that will provide a close-up of the interaction between wheels and regolith, assisting both the locomotion system and providing scientific insight into regolith behavior.

Six payloads are being considered in total:

NavCam: Observed scene goes to and above the horizon, but in practice, the scene is approx. 2m by 1m. The fully characterized stereo bench will allow to build a Digital Terrain Model of the 2x1m scene.

The resolution of the cameras is 2048 x 2048 pixels, a colored filter (Bayer RGB) is considered.

WheelCam: Two cameras with narrow field of view will observe the two left wheels. With the same sensor as NavCam, the projected pixel size will be in the range of 35-50 μ m on most of the scene. The WheelCams are panchromatic, but colored LEDs lighting the scene will allow multispectral imaging at night.

RAX: Derivate from the Raman spectrometer of the Exomars rover, RAX directly investigate the surface mineralogy of Phobos. Its spectral range from 530 to 700nm allow the identification of minerals, including water and organics. This provide valuable ground-truth regarding sample collection performed by the MMX spacecraft.

MiniRad: Based on MARA from MASCOT project, MiniRad is a radiometer to investigate Phobos surface at decimeter scale. It allows to determine surface emissivity in selected wavelength bands then derive the surface thermal inertia. Thanks to mobility, it allows to investigate surface heterogeneity by visiting different sites and geological units (fine regolith, boulders).

GRASS: This instrument is high sensitivity gravimeter. It allows to determine surface acceleration vector and its spatial and temporal variation to support the surface geophysics and geological substructure.

GRAMM: This instrument is a ground penetrating radar designed to probe the surface and near subsurface (down to 100m). One upon others, it can determine the variation in the density of the regolith and determine if the low density of Phobos should be due to high porosity or to water ice in the sub-surface.

6. ROVER DESIGN

Since the study started in 2016, many tradeoffs have been conducted. The result is, taking into account the mass and volume allocation, the power and thermal constraints, the rover has to be simple and safe. Smart landing platform with airbags or sky crane can't be achieved.

In the same way, an advanced locomotion concept like "the rocker bogie" cannot be applied. The risk is too high to roll down such a complex mechanism into the dust and the gravity is surely too low to cope with free joints.

6.1. Structure and locomotion

The rover is a simple box which contain almost all the system. It has four deployable rigid legs with four non-

directional wheels. Considering the low gravity and the very low speed targeted (0.1 to 4 mm/s), hyperstaticity should not be a major issue.

Hold down and release mechanism will be on the bottom side. The RF antenna is on the top side, protected from dust and shock at the landing by the folded solar arrays.



Figure 6. The rover in stowed configuration



Figure 7. The rover in operational configuration

Each leg consists of one shoulder and one wheel actuator. Due to the low temperature on Phobos, the current solution considers both actuators located in the rover body. Both actuators use identical brushless motors ILM25 from DLR (MASCOT heritage). Absolute position of shoulder joint is measured with potentiometers.

The wheel design has been optimized to improve traction into poorly cohesive environment – however, cohesion is expected to play a major role in the driving mechanics and significantly improve traction and controllability. It has a concave tread and asymmetric blade shaped grousers. Spokes at the rim are used to absorb landing and bouncing shocks.

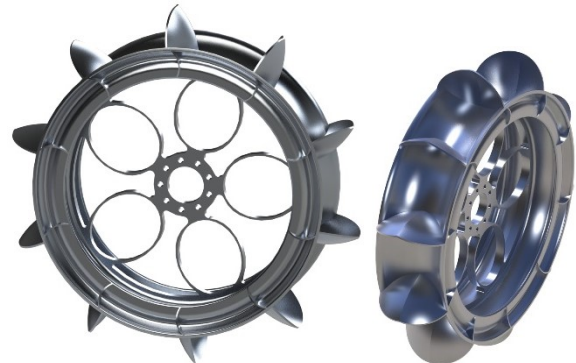

Figure 8. Provisional design of the wheel (mean diam. 210mm)

Without any steering of the wheel, point turn capabilities may be limited in soft regolith. It is planned to implement curve turns to limit the burying of the wheels.

6.2. Thermal concept and the energy issue

Phobos is quite cold (see chap. 3.3), so the interior of the rover is highly insulated in order to reduce as much as possible the power dissipated into heaters.

The thermal concept is to maximize the thermal decoupling between the chassis and an internal structure who supports all the equipment's. It means: a conductive decoupling through dampers and insulating washers; a radiative decoupling with 10 layers aluminized MLI between the internal module and the chassis; maximization of the harnesses thermal gradient length.

On the other hand, in order to keep the design as simple as possible, only three solar panels are folded on top of the rover leading to a limited number of solar cells. The sun power at Mars is limited also and is around 30 to 50% of the power available at Earth. Phobos is submitted to a day-night cycle, each lasting 3.5 hours, and the rover is unable to keep the sun normal to its solar arrays. These factors lead to a very limited amount of energy available each day. On the solar array, the simulations have shown an energy between 85 and 109Wh per Phobos day, in worst and best case respectively.

A large part of this energy is needed just to keep the inner temperature above the minimum allowed (0°C in order to preserve battery from early degradation).

All the mission will be driven by the available energy. In the nominal case, it is foreseen do something useful (drive, make science) each three Phobos days (so, each Earth day). The two others Phobos days, the rover will just restore the battery charge.

6.3. Computing power

At the contrary, in term of computing power, the rover will be much more capable than the other existing rovers. The foreseen on-board-computer comes from CubeSat technology recently develop by CNES.



Figure 9. CubeSat CPU board

This board embeds a System-on-Chip Zynq 7045 from Xilinx. One of its characteristics is to implement a 900MHz dual core Cortex A9 with Neon™ FPU. In term of memories, the board implement 1 GB DDR3 RAM and up to 256Gb NAND Flash. This CPU board has been

hardened by design since the beginning of the development (Latch-up protection, several level of supervision).

7. ROBOTIC CHALLENGES

The difficult environment of Phobos (see chap. 3) is the source of many challenges regarding the ambitious program of the rover mission (see chap. 5). The foremost challenge lies in the very low gravity. The expected local gravity at the landing site will divide the weight by a factor of 2000. Thus, any vertical speed higher than a few cm/s will send it flying many times its height in the air. Furthermore, the traction capability and more generally the driving performance that could be expected of such very low gravity are largely unknown. Indeed, gravity is not only a kinematic parameter, which would merely scale down the driving speed, as it strongly affects the type of particles found in the regolith, its nominal state and its behavior when plowed. In fact, the behavior of small body regolith is at the core of asteroid geophysics, making our locomotion challenge a scientific issue as well.

The second major challenge will be the stereo bench position. To set it on top of the usual pan/tilt mast would require too much heating power. Thus, the stereo cameras bench is fixed and heat shielded in the body, making autonomous navigation more challenging.

But, in the course of the mission, the first robotic challenge is not driving on Phobos. The rover will be jettisoned to the surface as a stone, it will most likely bounce several times and could end up in its final rest position in any attitude. Therefore, it has to upright itself before deploying its solar arrays.

7.1. Up-righting

Given the restriction on remote control capabilities, the rover must perform this critical operation in complete autonomy within one full battery charge. The basic concept of the up-righting is to use the legs as levers in order to make the body roll on the surface.

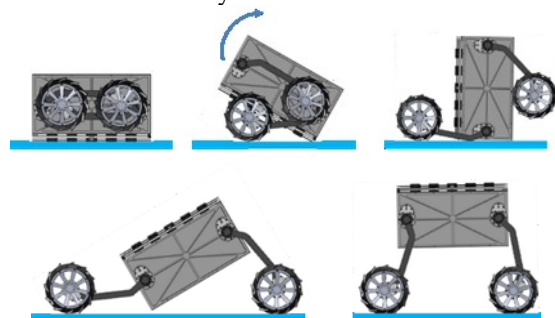

Figure 10. Up-righting from the upside down

If the rover rest on front, rear, top or bottom side, the up-righting consists in quite similar movements (see Fig 10). Rotation of the body is not based on unsteadiness/gravity so the sensitivity to the actual slope is low.

If the rover rests on one of its sides, the rover has to move on any of the other 4 faces. Several options are still open to do that. Depending on the nature of the regolith and on the final capabilities of the motorization system (still currently in definition phase), moving the buried legs may or may not be possible. If they can be moved, the rover should be able to reach an unstable position and tip on its belly or back. However, if they cannot, motion of the other two legs would not be enough to tip the rover on its other faces. So, in the current definition, a specific actuator is accommodated on the rear panel (see Fig. 11).

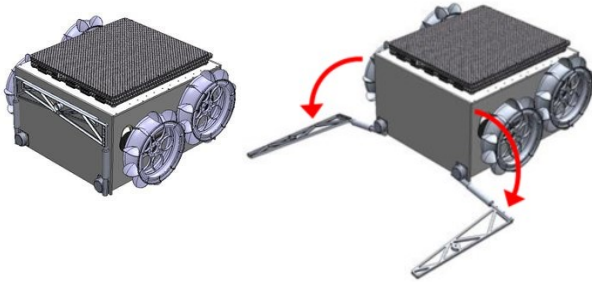

Figure 11. Actuator in stowed and activated positions.

After each actuation of legs or rear actuator, the rover has to determine if it's up-right or not. Several options are still opened to achieve that. The baseline is a direct measurement of gravity vector using very high sensitivity accelerometers in an Inertial Measurement Unit (IMU) (3 accelerometers + 3 gyrometers).

The inclination of the ground is expected to be at a maximum of 20° at the scale of the rover (3σ). An additional 10° slope is added to account for alterations to the ground caused by the rover, due to the landing and to the successive up-righting tries that may have dug up and/or compact the regolith.

The rover needs to differentiate between the position on its wheels and on its side. Due to the shape of the rover, this minimum angle is 105° .

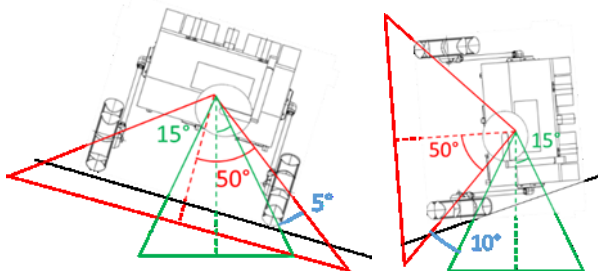

Figure 12. Up-right determination margins

Fig. 12 show a 10° margin against the false negative case and 5° margin against the false positive case, this allow an error of 15° for the gravity measurement direction.

Nota bene: it is considered that the landing site is chosen which will allow the rover to perform its nominal mission activities. As such, this site should also allow the rover to up-right itself – since, were that not be the case because of too many craters, boulders, cliff and crevasses, the rover would not be able to drive either.

7.2. Perception

Perception of the environment is key to enable any level of driving autonomy. The rover perception will be based on a couple of stereo cameras (see chap. 5.2 – NavCam). The IMU could be used also but, due to its power consumption, it will not be possible to keep it always ON. As the stereo bench is fixed inside the body, the optics have been selected with the widest Field of View (FoV) available of the shelf: 120° in diagonal. In order to see what happens in front of the front wheels, it is slanted down by 23° .

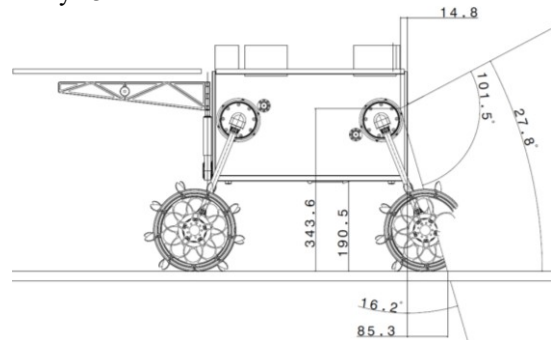

Figure 13. Vertical angles of the NavCam FoV.

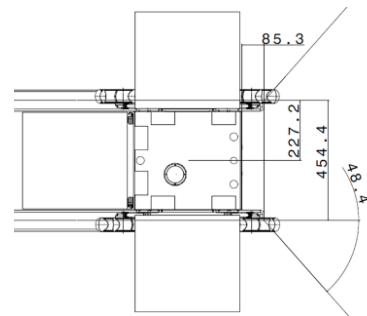

Figure 14. Horizontal angles of the NavCam FoV.

The stereo bench will have a 10 cm base or less, depending on the results of future simulations and tests.

7.3. Autonomous navigation

In the first few weeks after the landing, the rover will be operated in a classic way: the control center will assign a short trajectory to the rover based on the NavCam images sent by the rover on the previous communication slot (i.e. the previous day in the best energetic case).

But considering the useful size of the NavCam scene, this way of programming leads to a major limitation in term of achievable distance per driving session.

The blue bars in Fig. 15 give the scale on the ground. The second one (2m long, 2m from the rover) is probably the limit of 3D vision. But the density of forbidden region (in red) shows that driving autonomously will probably not be too hard. So, in order to increase the rover driving capability and time efficiency, CNES and DLR plan to implement this functionality in two different ways.

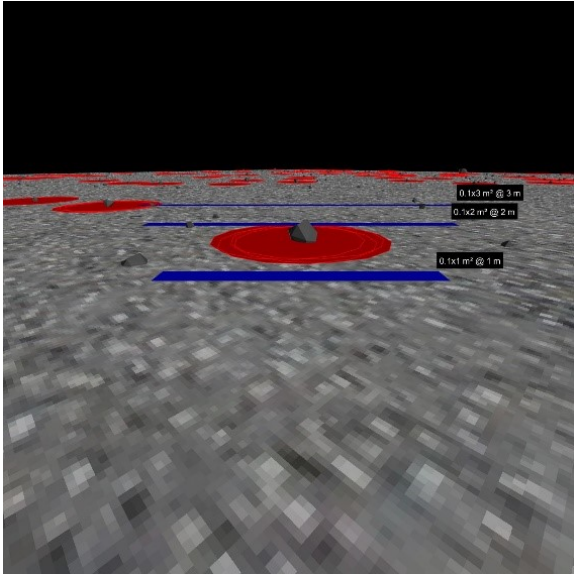

Figure 15. Simulated NavCam view based on the JAXA Environment Requirement Document (ERD)

The CNES autonomy will be derived from the autonomous navigation software delivered to the Exomars rover Rosalind Franklin. It has been specifically optimized for space use, so it requires low computing power and it has been extensively tested on ‘Mars yards’. The DLR software suite will be based on advanced algorithm from the robotic research center of Oberpfaffenhofen [6]. It will probably require much more computing power so one can expect high performances [7].

The basic concept of the rover software is quite classic: Stereo images → depth map computation → digital terrain model → navigable map generation → path planning.

The rover will perform a continuous planning: at each iteration, the planner computes a complete path to the objective. The intermediate waypoints are renewed in order to benefit from the new knowledge of the terrain. In the current definition of the autonomous navigation software, several level of autonomy are considered:

1. Full autonomy with some options regarding the trajectory control loop:
 - a. Closed loop: continuous planning with localization into the global map and trajectory control in closed loop.
 - b. Partially closed: relative localization only with Visual Motion Estimation function. Trajectory control could be in open or closed loop.
2. Reactive navigation: Continuous planning without localization. Obstacle avoidance only.

Option 1.a is the more complex and the more desirable. Option 2 is the lightest one. It does not require IMU measurements. Its drawback is to be less robust to the terrain, leading to seek help of the Control Center (and interrupt the mission) in any unexpected situation.

8. CONCLUSION

Mobile in-situ explorers of asteroids and comets have often taken the shape of hoppers, such as MINERVA or MASCOT [2]. Though their design shows clear advantages for the smallest of these bodies, they do come with drawbacks of their own. For bodies with sufficient gravity and with a relatively smooth soil of fine regolith, such as Phobos is described to be in the literature, our rover design presents an effective and capable mobility solution for scientific missions.

9. REFERENCES

- [1] Kuramoto, K., Kawakatsu, Y., Fujimoto, M., & MMX Study Team. (2017, March). Martian Moons Exploration (MMX) Conceptual Study Results. In *Lunar and Planetary Science Conference* (Vol. 48).
- [2] Ho, Tra-Mi et al. (2016). MASCOT—The Mobile Asteroid Surface Scout Onboard the Hayabusa2 Mission: Revealing the Evolution of C-Type Asteroid Ryugu. 10.1007/978-94-024-1538-4 18.
- [3] Ksanfomality, L., Moroz, V., Bibring, J., Combes, M., Soufflot, A., Ganpantzerova, O., Goroshkova, N., Zharkov, A., Nikitin, G., Petrova, E., (1989). Spatial variations in thermal and albedo properties of the surface of Phobos. *Nature* **341**, 588-591.
- [4] Basilevsky, A. T., Lorenz, C. A., Shingareva, T. V., Head, J. W., Ramsley, K. R., & Zubarev, A. E. (2014). The surface geology and geomorphology of Phobos. *Planetary and Space Science*, **102**, 95-118.
- [5] A. Wedler, M. Vayugundla, H. Lehner, P. Lehner, M. Schuster, S. Brunner, W. Stürzl, A. Dömel, H. Gmeiner, B. Vodermayr, B. Rebele, I. Grixia, K. Bussmann, J. Reill, B. Willberg, A. Maier, P. Meusel, F. Steidle, M. Smisek, M. Hellerer, M. Knapmeyer, F. Sohl, A. Heffels, L. Witte, C. Lange, R. Rosta, N. Toth, S. Völk, A. Kimpe, P. Kyr, and M. Wilde, First results of the ROBEX analogue mission campaign: Robotic development of seismic networks for future lunar missions, 68th International Astronautical Congress (IAC), 2017. paper no.: IAC-17-A3.IP.31.
- [6] M. J. Schuster, S. G. Brunner, K. Bussmann, S. Büttner, A. Dömel, M. Hellerer, H. Lehner, P. Lehner, O. Porges, J. Reill, S. Riedel, M. Vayugundla, B. Vodermayr, T. Bodenmüller, C. Brand, W. Friedl, I. Grixia, H. Hirschmüller, M. Kaßecker, Z.-C. Márton, C. Nissler, F. Ruess, M. Suppa and A. Wedler, Towards Autonomous Planetary Exploration: The Lightweight Rover Unit (LRU), its Success in the SpaceBotCamp Challenge and Beyond, *Journal of Intelligent & Robotic Systems (JINT)*, 2017.
- [7] M. Vayugundla, F. Steidle, M. Smisek, M. J. Schuster, K. Bussmann and A. Wedler, Datasets of Long Range Navigation Experiments in a Moon Analogue Environment on Mount Etna, in *International Symposium on Robotics (ISR)*, 2018.