

WHOI-81-74

*Copy 2*

*Woods Hole*

*Oceanographic  
Institution*



WHOI  
DOCUMENT  
COLLECTION

MECHANICAL AND OPERATIONAL DETAILS OF A  
NEIL BROWN INSTRUMENT SYSTEMS INTERNALLY  
RECORDING CONDUCTIVITY, TEMPERATURE, DEPTH  
(CTD) PROFILER

by

Richard P. Trask

September 1981

TECHNICAL REPORT

*Prepared for the Office of Naval Research  
under Contract N00014-76-C-0197; NR 083-  
400.*

*Approved for public release; distribution  
unlimited.*

WOODS HOLE, MASSACHUSETTS 02543

WHOI-81-74

MECHANICAL AND OPERATIONAL DETAILS OF A  
NEIL BROWN INSTRUMENT SYSTEMS INTERNALLY  
RECORDING CONDUCTIVITY, TEMPERATURE, DEPTH  
(CTD) PROFILER

by

Richard P. Trask

WOODS HOLE OCEANOGRAPHIC INSTITUTION  
Woods Hole, Massachusetts 02543

September 1981

TECHNICAL REPORT

*Prepared for the Office of Naval Research under Contract  
N00014-76-C-0197; NR 083-400.*

*Reproduction in whole or in part is permitted for any  
purpose of the United States Government. This report  
should be cited as: Woods Hole Oceanog. Inst. Tech. Rept.  
WHOI-81-74.*

*Approved for public release; distribution unlimited.*

Approved for Distribution: Robert C Beardsley for  
Valentine Worthington, Chairman  
Department of Physical Oceanography

MBL/WHOI



0 0301 0095404 6

## CONTENTS

	Page No.
ABSTRACT	i
ACKNOWLEDGEMENTS	ii
I. INTRODUCTION	1
II. CTD	5
III. RECORD MODULE	6
A. Battery Pack	6
B. Cassette Tape Transport	6
C. Tape Format	7
D. Tape Capacity	8
E. File Gapping	8
IV. OPERATIONAL ASPECTS OF THE CTD/IR	10
V. CALIBRATION	13
A. Laboratory Calibration of Pressure and Temperature	13
B. In situ Calibration System	14
C. Preliminary Data Processing	23
VI. CTD/IR USE AT SEA	27
A. Preparing the CTD/IR for Deployment	27
B. Monitoring the PDR	30
C. Water Samples	33
D. Turning the Record Modules Around	34
1. Removal of a Record Module	
2. Recharging a Record Module	
3. Cassette Installation	
4. Replacement of a Record Module	
Appendix I Modifications to the NBIS MK IIIB CTD	38
Appendix II Addition of a File Gap	39
Appendix III CTD/IR Station Log Sheet	40
References	41

## ABSTRACT

The purpose of this report is to discuss the use of a Neil Brown Instrument Systems internal recording CTD. The components of the instrument are described along with the advantages and disadvantages of the internal recording system. Calibration of the pressure and temperature sensors in the laboratory and the method used for in situ calibration of the conductivity sensor is described. A step by step description of the use of the CTD/IR at sea is also included.

ACKNOWLEDGEMENTS

I would like to thank Mel Briscoe and Bob Weller for their critical review of the text; Nancy Pennington for overseeing all the graphics work and Mary Ann Lucas for typing the text and making numerous revisions. This work was supported by the Office of Naval Research under Contract No. N00014-76-C-0197, NR 083-400.

## I. INTRODUCTION

The instrument described in this report is a Neil Brown Instrument Systems (NBIS) internal recording conductivity, temperature and depth (pressure) profiler, referred to as the CTD/IR. It differs from a conventional NBIS Mark IIIB CTD system in that it is battery powered and has internal recording capabilities. Despite the modifications to allow internal recording and battery powered operation the specifications of the Mark IIIB also apply to the CTD/IR, with the exception of the recording interval.

The underwater unit consists of two components. The lower component contains the sensors and the major portion of the electronics. For clarity and compatibility with the NBIS technical manuals the lower unit will be referred to as the CTD. The upper component of the underwater unit, referred to as the Record Module, contains the battery pack, and the cassette tape recording unit and its associated electronics. The CTD and Record Module are joined and individually hermetically sealed by means of an intermediate bulkhead that is placed between the two units. Flanges on the bulkhead and on the pressure cases of the record module and CTD provide an attachment point for two circular V shaped clamps. These clamps, referred to as Marmon clamps, hold the three pieces together. Additional Marmon clamps are used on the top end cap of the record module and on the bottom end cap of the CTD. Figure 1 shows the individual pieces of the underwater unit.

The CTD/IR is turned on by shorting a two pin connector attached to the top end cap of the record module. This can be done by a shorted plug or by a messenger activated switch, thus providing a means of remote operation. The third component of the system is the Charger/Controller which has two modes of operation. This unit can be used to either charge the batteries in the Record Module, or to interconnect the CTD/IR with an optional NBIS Deck Data Terminal.

This report is not intended as a technical manual for this system, but rather will discuss those components which make it different from

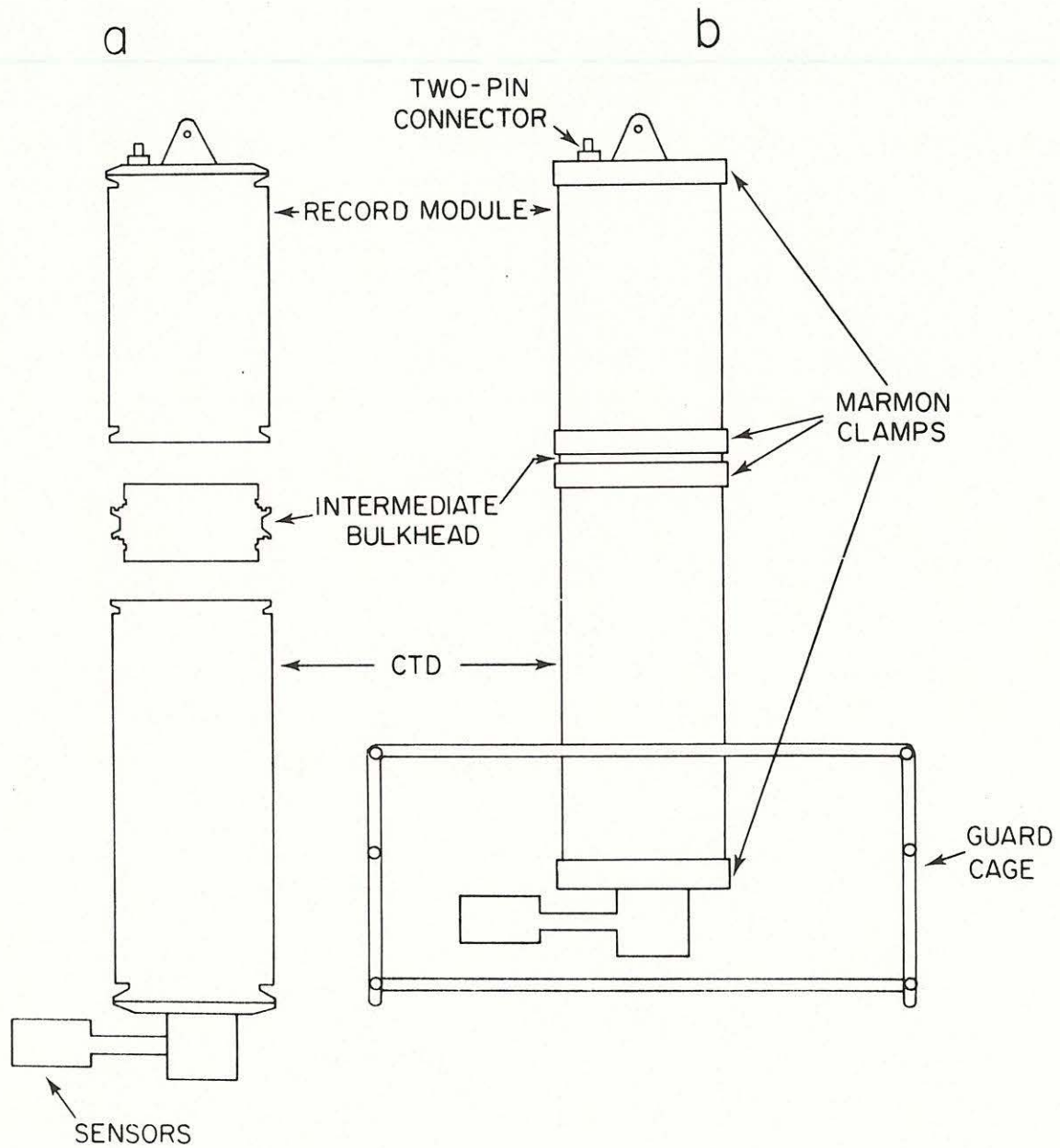

Figure 1. Individual components of the CTD/IR underwater unit shown apart in (a) and assembled in (b).

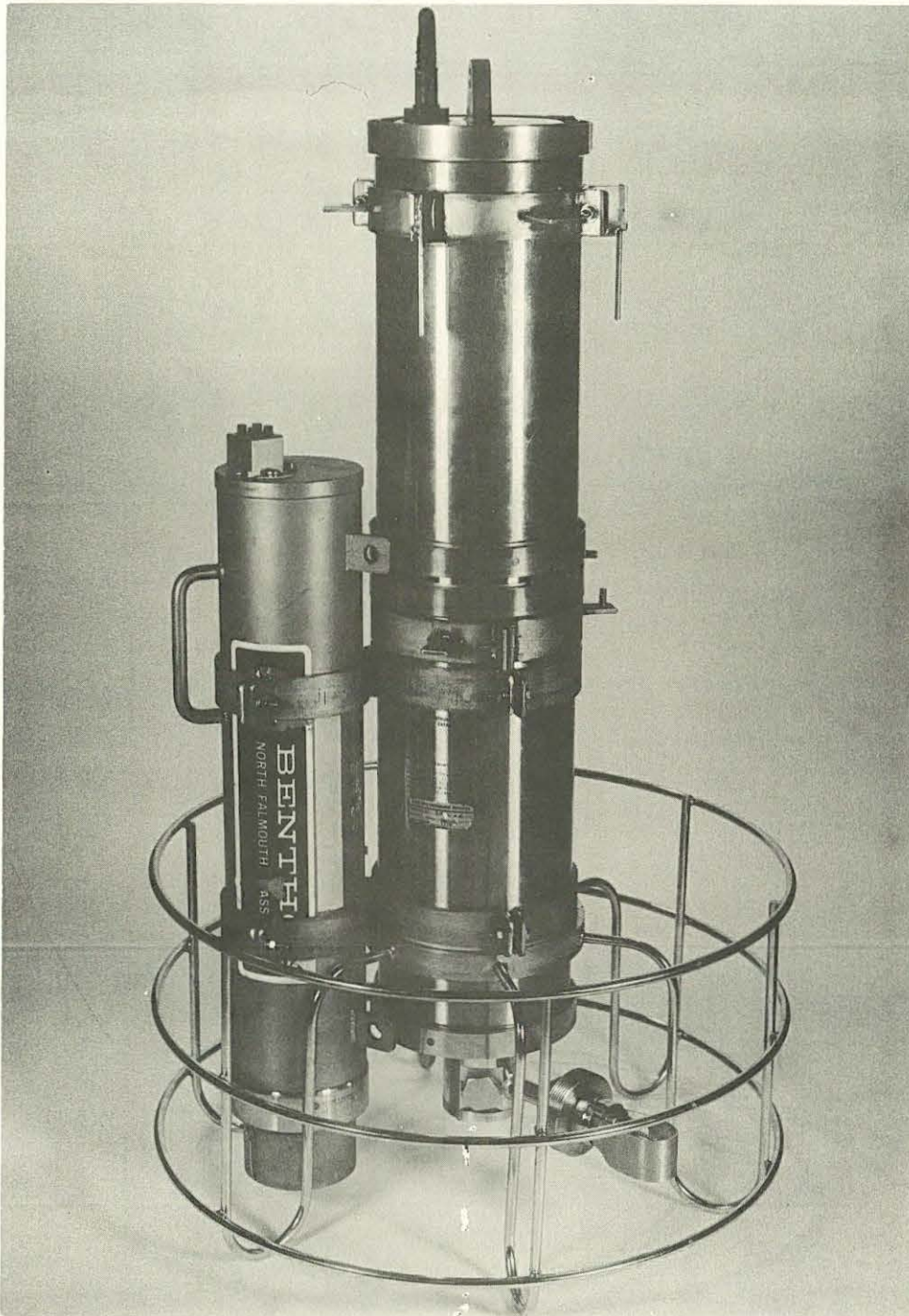

Figure 2. A photograph of the CTD/IR fully assembled with Benthos Pinger. The additional stainless hardware clamped around the pressure case holds the in situ calibration system.



conventional CTD systems and in particular the NBIS Mark IIIB CTD. Much of the technical information in this report has been obtained from Brown and Morrison (1978) and the NBIS CTD/IR manual. This report will also discuss the use of a CTD/IR system with respect to a specific deep water application, and will attempt to point out particular drawbacks and partial solutions.

## II. CTD

The system from which the CTD/IR evolved is a NBIS MK IIIB CTD. The MK IIIB profiler is a ship lowered instrument which measures conductivity, temperature, and pressure and telemeters the digitized data to a shipboard deck unit and computer system via a single conductor shielded cable. Electronic modifications made to the MK IIIB which permit battery operation and internal recording are detailed in Appendix I. Such modifications eliminate the necessity of a conducting cable.

The sensor assembly and pressure case design of the CTD is unchanged from the NBIS Mark IIIB. The sensor assembly consists of a 3 cm long, 4 electrode conductivity cell, a platinum resistance thermometer with an optional add on fast response thermistor, and a strain gauge pressure transducer with a temperature compensating collar. The system described in this report has had the fast response thermistor removed. Its input to the temperature interface board has been replaced with a  $10\Omega$  resistor. The recording interval of this system is .256 seconds; however, several other intervals (.128 s, .512 s, and 1.024 s) are jumper selectable.

In order that the Record Module could be attached to the CTD the top end cap of the MK IIIB was replaced with an intermediate bulkhead which mates the Record Module to the CTD. This bulkhead provides an independent pressure proof water-tight seal to both the CTD and the Record Module. The Record Module can, therefore, be removed from the CTD/IR without opening the lower unit. In addition, should either unit flood, the other is protected. Electronic connection between the two units is accomplished by means of an internal cable from the Record Module and a bulkhead connector.

### III. RECORD MODULE

#### A. Battery Pack

The record module contains the battery pack, cassette tape recording unit, and associated electronics. The battery pack is made up of 17 "C" sized rechargeable nickel-cadmium batteries in series. The capacity of the battery pack is 2.0 ampere-hours, sufficient to operate the cassette recorder for the duration of an extended cassette. The batteries are recharged at a rate of .2 ampere by means of the Charger/Controller. Total charging time is approximately 13 hours; however, the batteries may be left on charge at the .2 ampere rate indefinitely without damage. The record module need not be connected to the CTD in order to charge the batteries. The procedures for charging a record module are outlined in section VI, part D2. The NBIS CTD/IR manual warns that the Nickel-Cadmium batteries may vent under abnormal use. Conditions under which the batteries may vent are excessive charging current, i.e. greater than 200 mA; short circuit or abnormally low resistance load; excessive ambient temperatures, i.e. greater than 60°C; and the occurrence of a cell reversal due to one cell in the series exhausting its capacity before the other cells are depleted. Greater detail on these causes of venting and precautionary measures are discussed in the NBIS CTD/IR manual.

#### B. Cassette Tape Transport

The cassette tape recorder installed in our CTD/IR is a Sea Data Corporation Model 610 Serial Digital Stepping recorder. To gain access to the tape transport the record module must be removed from the CTD. A splash guard which protects the internal workings of the record module from the weather, sea spray, etc. during disassembly must be withdrawn from the lower end of the record module. This exposes the Sea Data cassette transport. The cassettes used with this system should be certified data cassettes of either 300 or 450 feet in length. As standard procedure every tape installed in the CTD/IR system is erased

and checked on the tape reading system. This assures the operator that the tapes are in the best possible condition prior to their installation. The procedures for installing a cassette are outlined in section VI, part D3. With the cassette in place and the tape transport still visible it has been our standard procedure to power up the CTD/IR and observe the tape drive for approximately one minute. This requires electronically linking the CTD with the record module by means of the eight conductor internal cable. The CTD/IR is turned on by shorting the two pin underwater connector on the top end plate of the record module. This is the same connector used to charge the batteries. A special underwater shorting plug is used for this purpose. Once the operator is satisfied that the cassette has been installed properly and that the tape transport is functioning as it should the system can be shut off and the record module closed up. Closing procedures are outlined in section VI, part D (Removal and Replacement of a Record Module).

### C. Tape Format

The format used to record the data on tape as taken from the NBIS CTD/IR manual is shown below. Four bit positions occupy the equivalent space of one step.

		Bit No. (LSB to MSB)
Inter-record gap	9 step	
Preamble	2 step	
Pressure Magnitude	16 bit	1 - 16
Temperature Magnitude	16 bit	17 - 32
Conductivity Magnitude	16 bit	33 - 48
Pressure Sign	1 bit	49
Temperature Sign	1 bit	50
Dummy (not used)	1 bit	51
"1" for 10 seconds at Turn-on	1 bit	52
Dummy (not used)	4 bit	53 - 56
Parity	1 step	

Thus, 56 bits of data form a record. The Sea Data recorder writes to tape a 9 step inter-record gap and a 2 step preamble followed by the 56 bit (14 step) data record and a 1 step parity character. The least significant bit is written on the tape first.

#### D. Tape Capacity

A complete data cycle, including the inter-record gap and the preamble in the beginning and the one step for the parity at the end, consists of 26 steps. Since the format of the tape allows 800 steps per inch a cassette with 300 feet of tape can hold 110769 records (450' tape holds 166153 records). The recording time therefore depends on the sampling interval and the length of the tape in the cassette. Table I shows the recording time (hours) per sampling interval for the 300 and 450 foot cassette tapes.

#### E. File Gapping

If the instrument is turned on and then off more than once while filling one cassette the original means of detecting the beginning of intermediate turn-ons is by monitoring the bit stream. As originally designed, at the time the instrument is turned on, bit 52 goes high for 10 seconds. This is the only indication that the instrument has been restarted. As designed there is no file gapping. This, however, was modified in our particular system. With the addition of a capacitor in the head driver circuitry of the tape transport a file gap occurs before writing data to tape each time the instrument is turned on. For details see Appendix II. This feature aids substantially in the data processing of the cassette tapes and allows for manual positioning of the tape to a desired file.

Table I  
Recording time [hours] per sampling interval for  
the 300 and 450 foot cassette tapes.

Sampling Interval [seconds]	Cassette Tape Length	
	300'	450'
.128	3.9	5.9
.256	7.9	11.8
.512	15.7	23.6
1.024	31.5	47.3

#### IV. OPERATIONAL ASPECTS OF THE CTD/IR

The internal recording aspect of the CTD/IR permits a degree of flexibility not available in other conventional CTD systems. There are of course certain inconveniences. In our application, however, the advantages of a flexible system outweigh the inconveniences. Our CTD/IR was intended to be used on relatively short cruises to gather data from approximately 20 stations. To prevent any delay in data collection due to time spent charging the Record Module a spare Record Module was acquired. This essentially permits around the clock use of the CTD/IR. One Record Module would be charging while the other was in use.

The minimum amount of equipment which is required to take to sea when using this system is only the CTD/IR and the small Charger/Controller. Since the data is written to a cassette internally all the data processing can be done at home eliminating the need for large shipboard computer systems. Another advantage of this system is that it can be deployed using any standard hydrographic wire. The conducting cable and all its associated problems are no longer necessary. These advantages are particularly helpful when doing work from ships of opportunity. Large amounts of equipment do not have to be transported to the ship. In addition the requirements of the ship in regards to winch and cable are minimal.

It has been our standard procedure to bring to sea the data processing equipment in order that the quality of the data can be given a first order check to assure the operators that the system is working properly. It is also possible to do a major portion of the initial data processing while at sea.

Since there is no real time output of data from the CTD/IR, the instrument depth (pressure) is not known directly. To eliminate this problem a Benthos Deep Sea Pinger Model 2216 was added to the instrument package. The pinger, when used in conjunction with a 12 KHz Precision Depth Recorder (PDR), continually provides the information needed to determine the height of the CTD/IR above the bottom as it is lowered to

any ocean depth. The Benthos Pinger emits a 12 KHz acoustic pulse once every second. The PDR in turn receives the direct pulse from the pinger and seconds later receives the bottom reflected pulse. The time interval between receiving the two signals is an indication of the distance the pinger is from the bottom. The time interval is displayed graphically on the PDR which aids in the interpretation.

In the air the CTD/IR weighs approximately 172 pounds. With the addition of the Benthos Pinger, and the in situ calibration system to be discussed in the next section, the weight of the instrument package exceeds 260 pounds. In calm seas the instrument can be deployed by two people, however, in rough weather three or even four people are often needed.

One aspect of the system which needs routine inspection is the Marmon clamps. Marmon clamps have been known to crack in the region of the T bolt where the steel has been rolled. Careful inspection of every clamp whether it has been removed or not is essential. Failure to detect a faulty clamp could result in the loss of the instrument.

Since the CTD/IR sensors are extremely delicate and rather costly to replace if broken a sensor guard which differs from that supplied by NBIS has been used on the CTD/IR. The new design was intended to be easy to remove and replace, and sturdy enough to provide protection against waves, etc. while the CTD/IR is sitting on deck. The sensor guard consists of two parts, a stainless steel piece which is permanently attached to the sensor assembly and a protective PVC cap which screws onto the stainless steel base. The threaded stainless base shown in Figure 3, consists of two mating halves which clamp around the sensor assembly shaft. The cap is a short piece of PVC pipe with one end sealed and the other end tapped to mate the threads on the stainless base. The protective cap is easily unscrewed and removed prior to each cast, exposing the sensors.



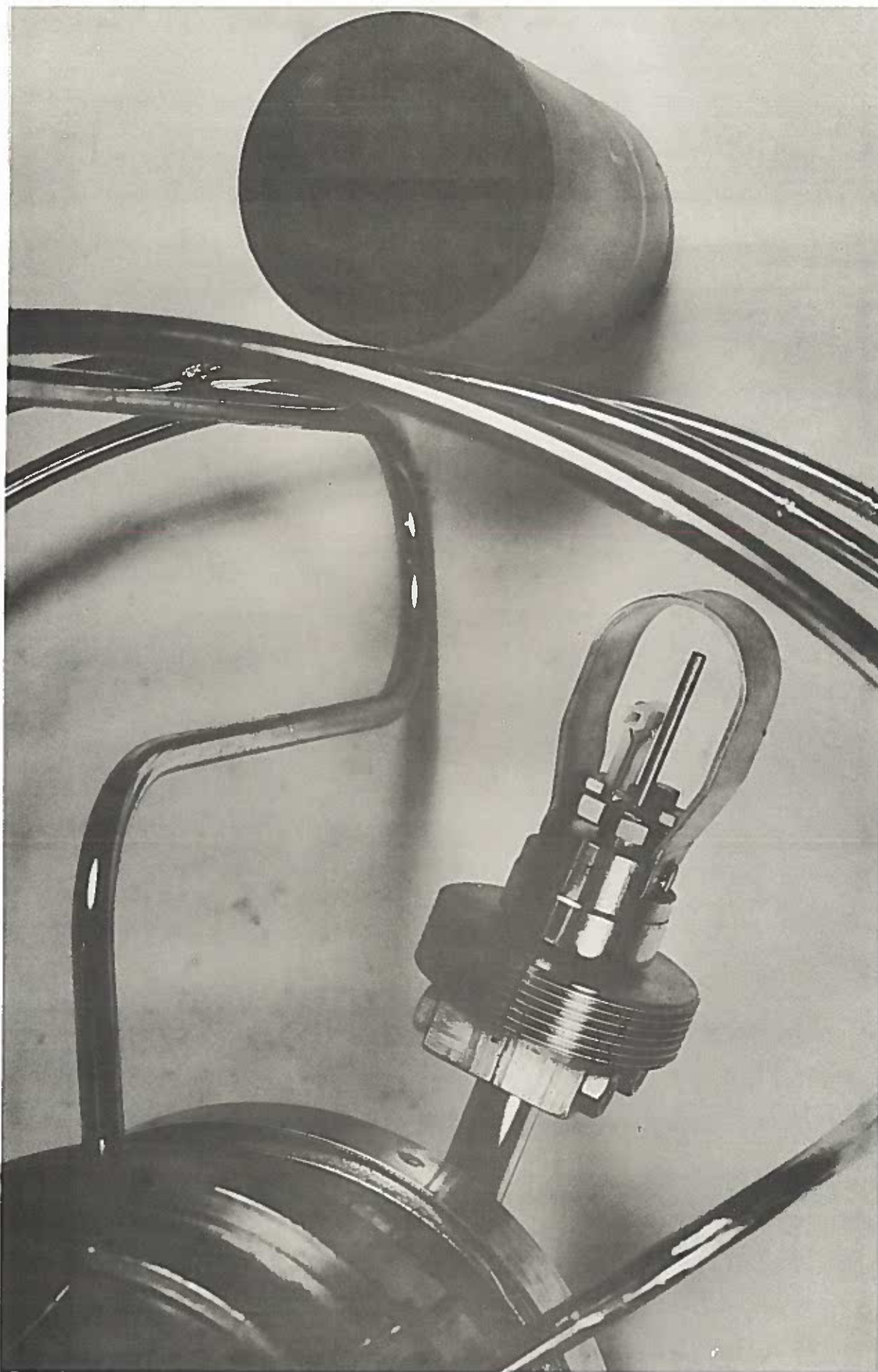

Figure 3. A photograph of the components of the CTD/IR sensor guard assembly which includes a threaded stainless base attached around the sensor assembly shaft, and a PVC cap which screws onto the base, protecting the sensors.

## V. CALIBRATION

The CTD/IR undergoes pre and post cruise calibrations at W.H.O.I. The temperature, pressure and conductivity sensors are calibrated against a NBIS calibration unit transfer standard. The temperature and pressure calibration rely totally on the laboratory findings. Since the conductivity cell is subject to drift, field calibrations are required in order to ensure accuracy greater than .012 psu (practical salinity units\*) (Millard, 1981). Laboratory calibration of the conductivity sensor is merely a check on the linearity of the sensor.

### A. Laboratory Calibration of Pressure and Temperature

The laboratory calibration of the temperature and conductivity sensors involves total immersion of the underwater unit in a bath of approximately 35 psu. The bath is initially warmed to a temperature of approximately 30°C. The water temperature is then reduced by steps of approximately 5°C down to 0°C. During the calibration real time output of CTD/IR data is obtained by using the Charger/Controller to connect the CTD/IR with an NBIS Deck Data Terminal. Readings of temperature and conductivity are made nearly simultaneously from the Deck Data Terminal and the NBIS calibration unit transfer standard. Differences between the corresponding readings from the two units are calculated and plotted.

In order to convert the temperature data recorded on tape to scientific units, NBIS specifies that the raw binary data be multiplied by .0005 deg C/count. This is the slope of the nominal temperature vs counts curve. This slope can be finely tuned by means of the laboratory calibration data. It has been our experience that for the temperature range of 0 to 30°C accuracies of  $\pm .001^\circ\text{C}$  are obtainable by adjusting the slope.

---

\* The term practical salinity unit (psu) has the same meaning as parts per thousand (ppt or ‰) but is used here to distinguish those salinity calculations made using the 1978 practical salinity scale algorithm (Fofonoff, 1981).

The pressure transducer is calibrated in the laboratory using a deadweight tester. Corrections applied to the deadweight pressures are described in Fofonoff et al (1974). NBIS specifies the nominal slope of the pressure vs. counts curve to be 0.1 dbar/count. With our instrument, adjustments to the nominal calibration have not been necessary. Accuracies of  $\pm 0.5$ ,  $\pm 2.6$  dbar over the range of 0 to 6000 dbars are obtained with the nominal calibration. Between 2000 and 6000 dbars the accuracy with the nominal calibration increases to  $\pm 0.5$ ,  $\pm 1.5$  dbars.

In the event that the temperature and pressure sensors require more extensive calibration adjustments, procedures followed by the W.H.O.I. CTD group are outlined by Millard (1981).

#### B. In situ Calibration System

In order to improve the accuracy of the conductivity measurements water samples should be obtained so that a comparison between the calculated CTD salinities and water sample salinities can be made. A water sampling scheme that can be used in conjunction with the hydrowire is advantageous since it will maintain the flexibility of the CTD/IR system. This rules out the use of a rosette sampler often used with conventional CTD systems. Several options are, however, available. Nansen or Niskin bottles can be attached to the hydrowire and tripped by a messenger at the desired time. The number of bottles used depends on the science requirements, time, and manpower. With a number of bottles on the wire more time is required in order to attach the bottles, wait for them to trip, sample the area at each bottle location with the CTD, and finally remove the bottles from the wire. Since the exact depth where the bottles eventually tripped is not well known, sampling the suspected area with the CTD during the up-cast, and then making a comparison with the bottle sample could produce some misleading results.

In the case of our internally recording CTD it is desirable to conserve battery power by shutting the CTD off at the end of the down-cast. This presents several problems. First, once the CTD is shut off it is impossible to sample the location where the bottles tripped.

Secondly, a vertical spacing of several meters between the CTD and the nearest Niskin bottle is required in order that the messenger dropped by that Niskin bottle gains the speed required to activate the shut-off switch on the CTD. This prevents having a sample bottle relatively close to the CTD sensors. The search for a partial solution to these problems led to the design of a messenger activated mechanism that simultaneously closes three Niskin bottles that are clamped to the CTD, doubles the Benthos pinger rate and shuts off the CTD/IR. By having the Niskin bottles attached to the CTD/IR pressure case the water samples are taken as close to the sensors as possible. Doubling the pinger rate (an option provided by Benthos, Inc.) provides a time mark as to when the water samples were taken. Shutting off the CTD has a two fold purpose. No only is battery power conserved, but there is little confusion that the last records should be compared with the water samples for the insitu calibration.

The individual components of the insitu calibration system will be discussed next.

The tripping mechanism shown in detail in Figure 2 is fabricated from high density polyethylene which was selected for its strength and low water absorption. The "J" shaped pins are stainless steel as is all the other hardware. Figure 3 shows the basic components of the in situ calibration system. For purposes of simplicity and clarity just the representative components of the system are shown. The tripping mechanism is supported above the CTD/IR by means of a stainless steel tripod. This keeps the tripping unit above the hydrowire termination and allows the messenger to make an unobstructed descent. A Miller swivel is placed between the hydrowire termination and the CTD in order to prevent the translation of any torque in the wire to CTD/IR rotation. Any rotational movement of the CTD/IR would inhibit the flow of water through the conductivity cell.

The switches used in conjunction with the pinger and the CTD/IR are Benthos Switches Model 1752. The switch that turns the CTD/IR off is designated as normally open and the switch used with the pinger is

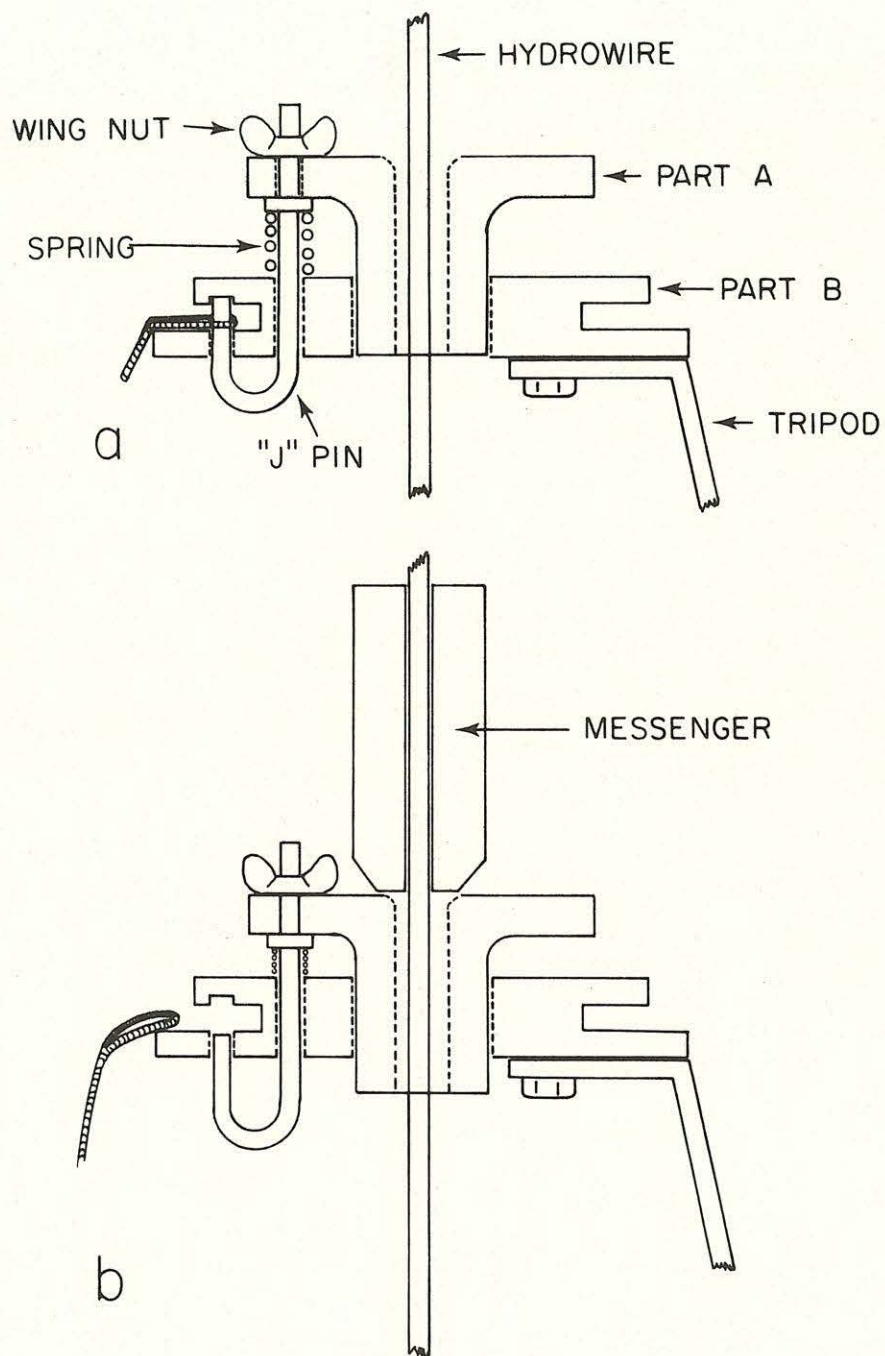

Figure 4. A cross-sectional view of the tripping mechanism, used to activate the sampling bottles and the switches, is shown before (a) and after (b) activation.

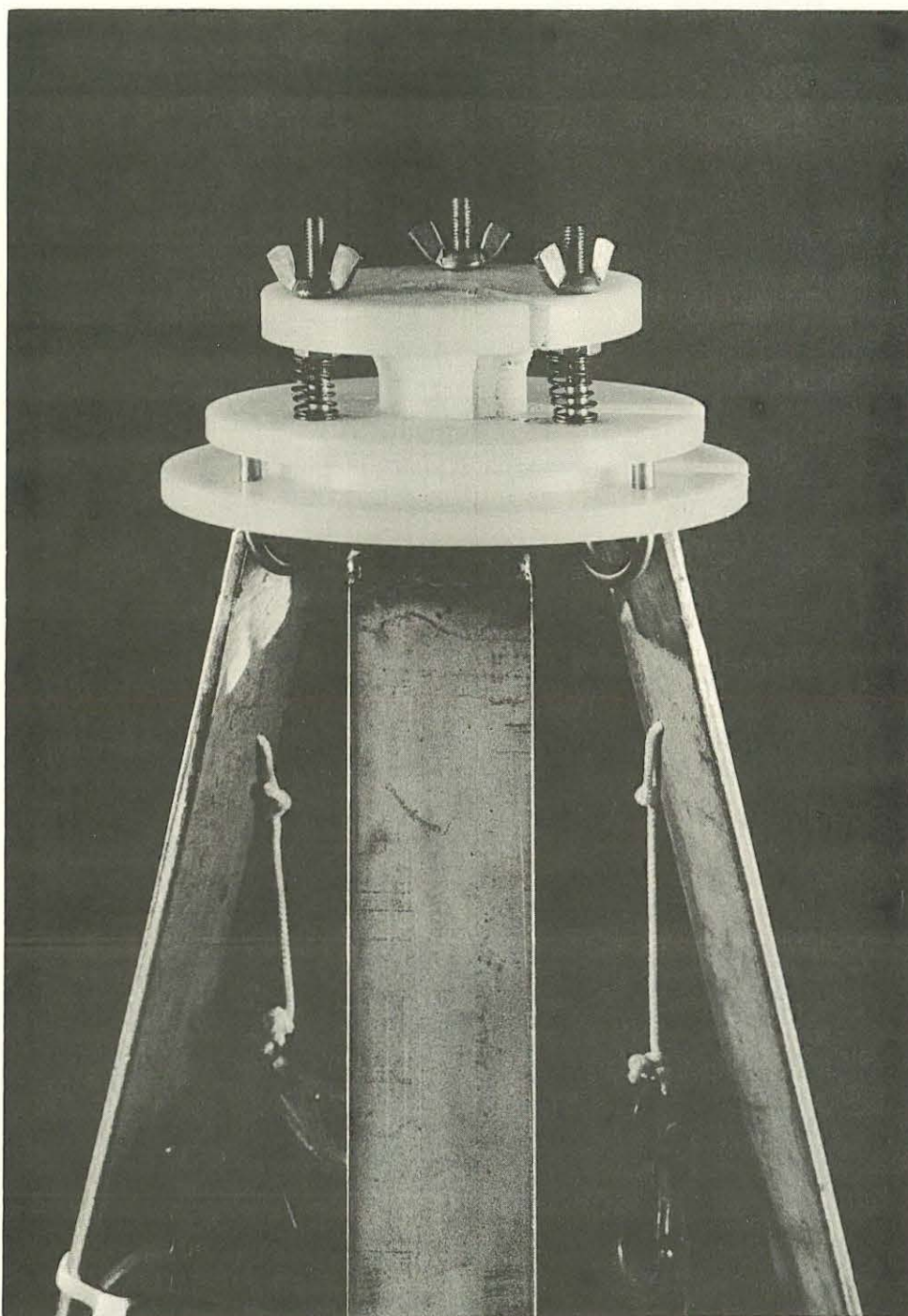

Figure 5. A photograph of the tripping mechanism attached to the tripod. The snap clips below are each attached to a Benthos underwater switch (not shown). The short lengths of string prevent the clips from interfering with the sampling bottles below (also not shown).

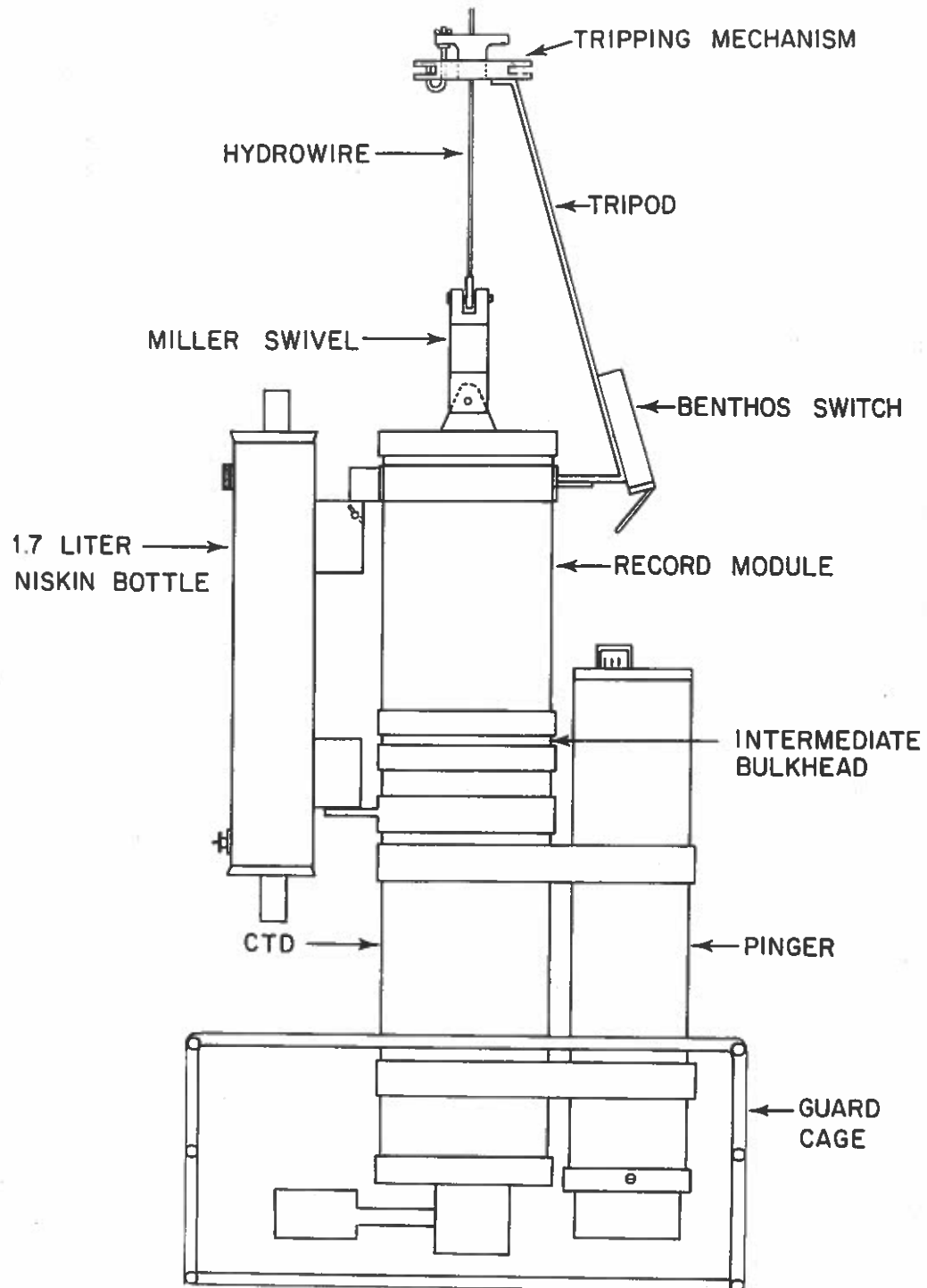

Figure 6. A schematic showing the CTD/IR and the basic components of the in situ calibration system.

normally closed. This configuration may seem reversed but it is not because the switches are mounted upside down with respect to their designed use. The normally open switch, which is connected to the two pin connector on the top end plate of the Record Module, is placed in the closed position by a short lanyard to the tripping mechanism for the duration of the down cast. This configuration duplicates the purpose of the shorting plug. At the bottom of the cast the switch is returned to its normally opened position, shutting the CTD off. The means by which this occurs will be discussed in a later section. The two switches are each attached to a leg of the tripod with the switch lever facing down. The switches are spring loaded which forces their levers to return to their normal position.

The Niskin bottles are attached to the CTD/IR by means of stainless steel brackets. The brackets were designed such that the hydrowire clamping mechanism on the Niskin bottles could be utilized. This permitted easy installation and removal. Modifications to their lanyard design were made as shown in Figure 4.

Figure 4 shows the components of the in situ calibration system as they would appear just prior to the deployment of the CTD/IR. The procedures for preparing the system for deployment appear in section VI, part A. The instrument is lowered through the water at approximately 60 meters/min to the desired depth. All the while the PDR is monitored for an indication of the instrument's position off the bottom. At the appropriate time a messenger is placed on the hydrowire and dropped. The messenger travels toward the tripping mechanism at approximately 250 m/min. When the messenger hits, it pushes part A of the tripping mechanism down which in turn moves the "J" pin which releases the lanyards from the Niskin bottles, allowing the bottles to close. At the same time the short lanyards from the Benthos switches are released which in turn double the ping rate and turn the CTD/IR off. Upon detecting the double ping rate with the PDR the CTD/IR is hauled to the surface. Once on deck water samples are drawn from each Niskin bottle. These samples are then analyzed using a Guildline "Autosal" Salinometer either at sea



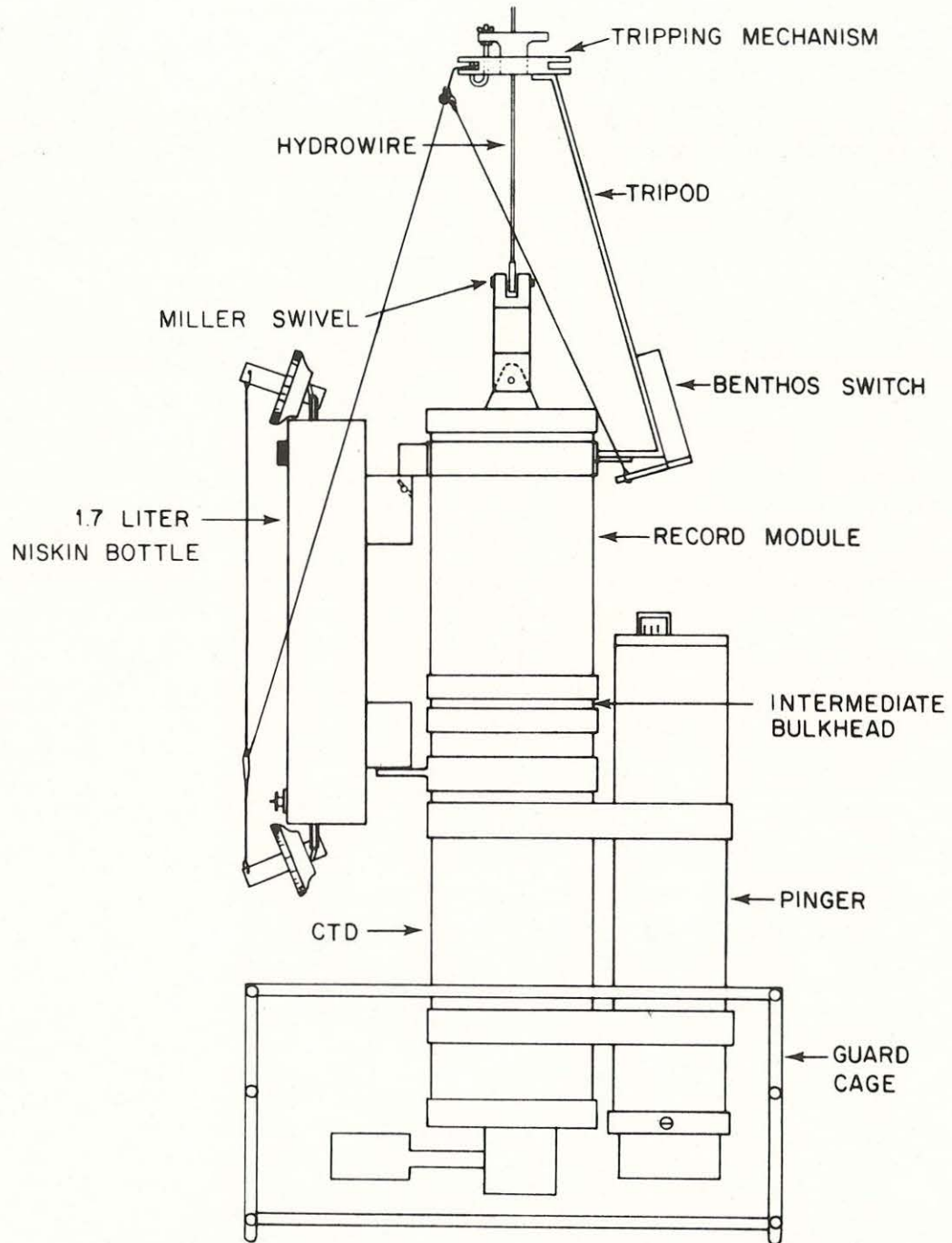

Figure 7. A schematic showing the CTD/IR and the basic components of the in situ calibration system as they would appear prior to deployment.

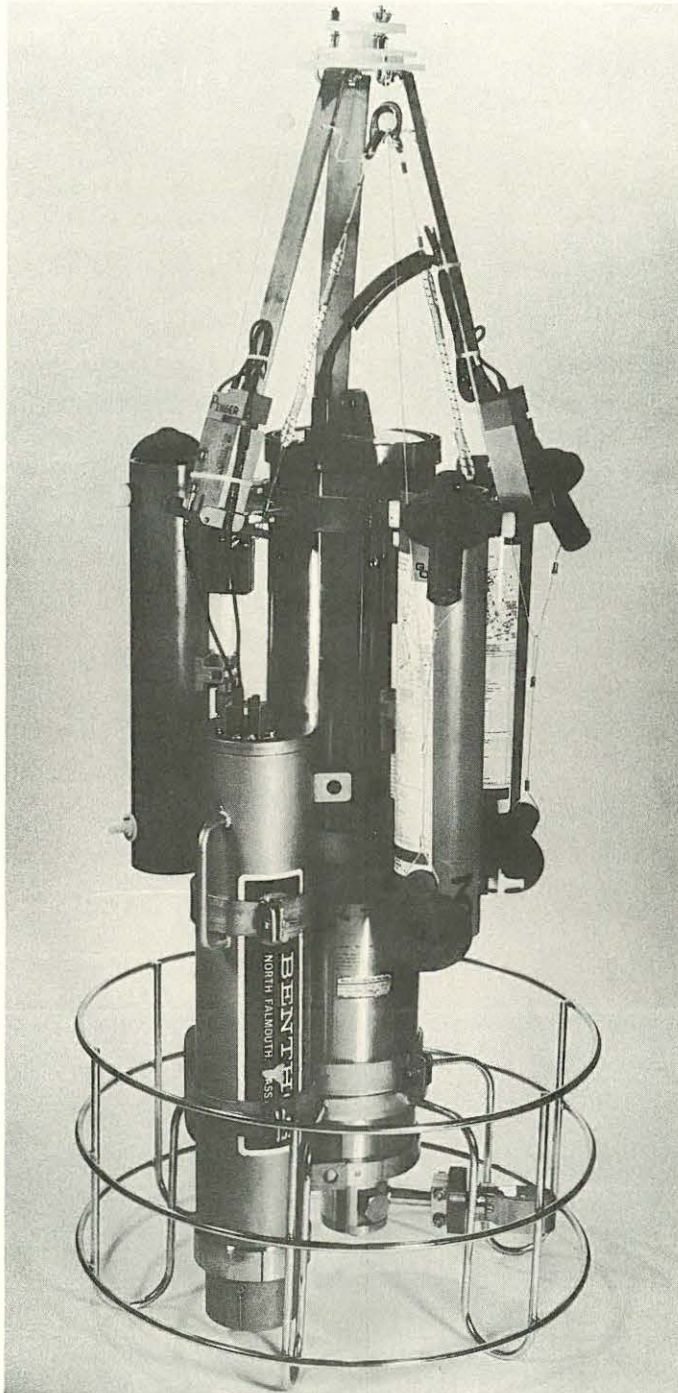

Figure 8. A photograph of the CTD/IR with the entire in situ calibration system mounted and ready for deployment.

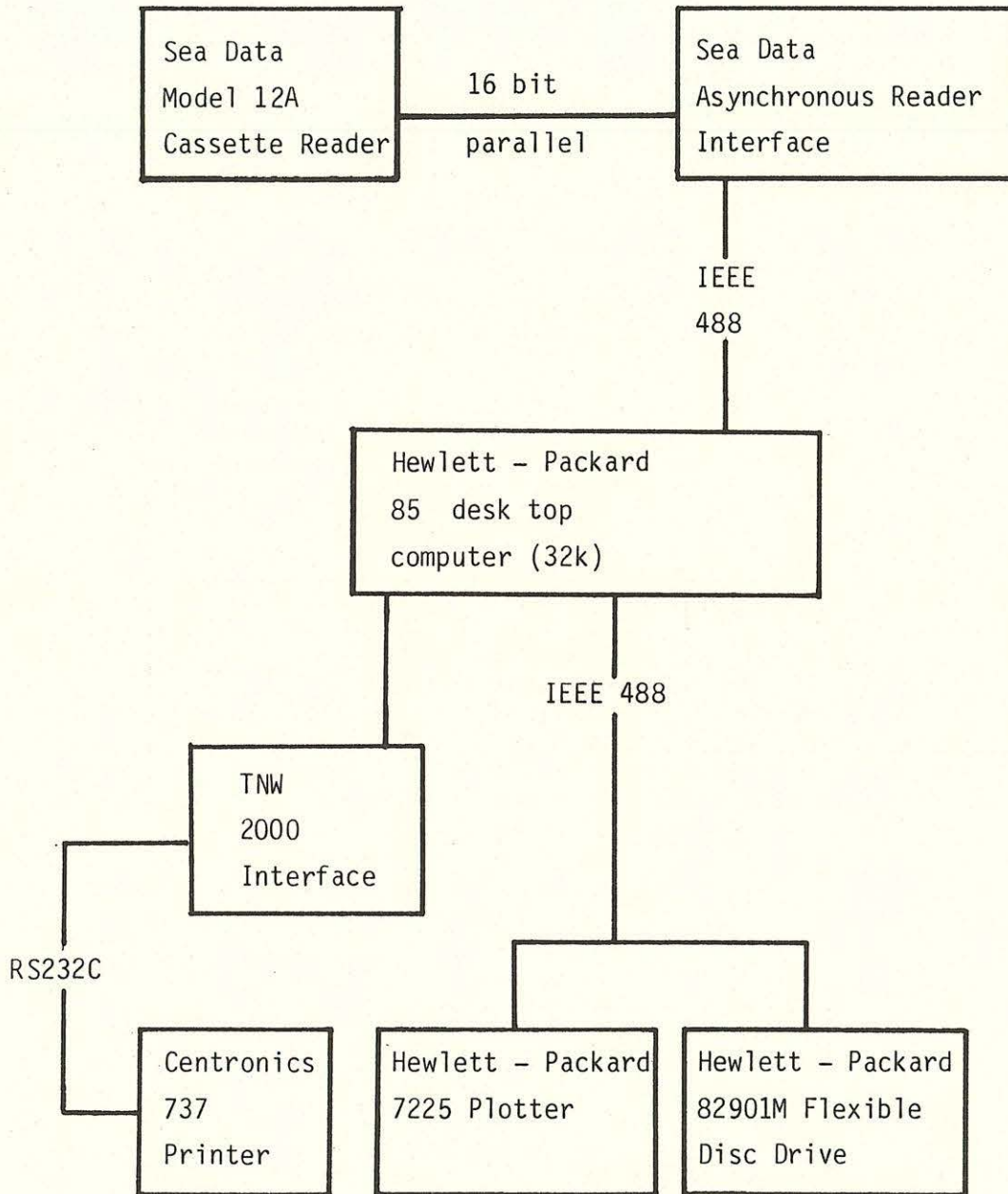

Figure 9. The components of the computer system used for preliminary data processing.

or when the samples return to W.H.O.I. A detailed description of the use of the CTD/IR at sea appears in section VI.

### C. Preliminary Data Processing

The computer system presently used for preliminary data processing is shown schematically in Figure 5. The data cassettes from the CTD/IR are read by a Sea Data Model 12A reader which is interfaced to a Hewlett-Packard (HP) 85 computer by means of a Sea Data Asynchronous Reader Interface. The processed data from the HP85 can be output to either a Centronics printer or HP plotter for presentation or stored on flexible disc.

The procedure for processing the CTD/IR data is shown schematically by the flow chart in Figure 6. The products in terms of data from a CTD/IR cast are a data cassette and several water samples. The raw data from the cassette are input into an HP85 computer program called CLOOK (for CTD Quick Look) which applies the nominal calibrations and allows the operator to have a preliminary look at the data. The pressure and temperature calibrations can be initially adjusted if necessary based on the laboratory calibrations. The nominal calibration applied to the conductivity as suggested by NBIS is .001 mmhos/count. In addition the program corrects the conductivity readings for errors due to conductivity cell deformation from both temperature and pressure shrinking the conductivity cell as described by Fofonoff, et al (1974):

$$C = C_{CTD}(1 - \alpha(T) + \beta(P))$$

where  $C_{CTD} = \text{Binary count} * .001 \text{ mmho/count}$ , and

$$\alpha = 6.5 \times 10^{-6} \text{ cm/cm/}^{\circ}\text{C}$$

$$\beta = 1.5 \times 10^{-8} \text{ cm/cm/decibar}$$

The program then calculates salinity from the pressure, temperature and conductivity data using the 1978 practical salinity scale algorithm (Fofonoff, 1981). Potential temperature may also be calculated.

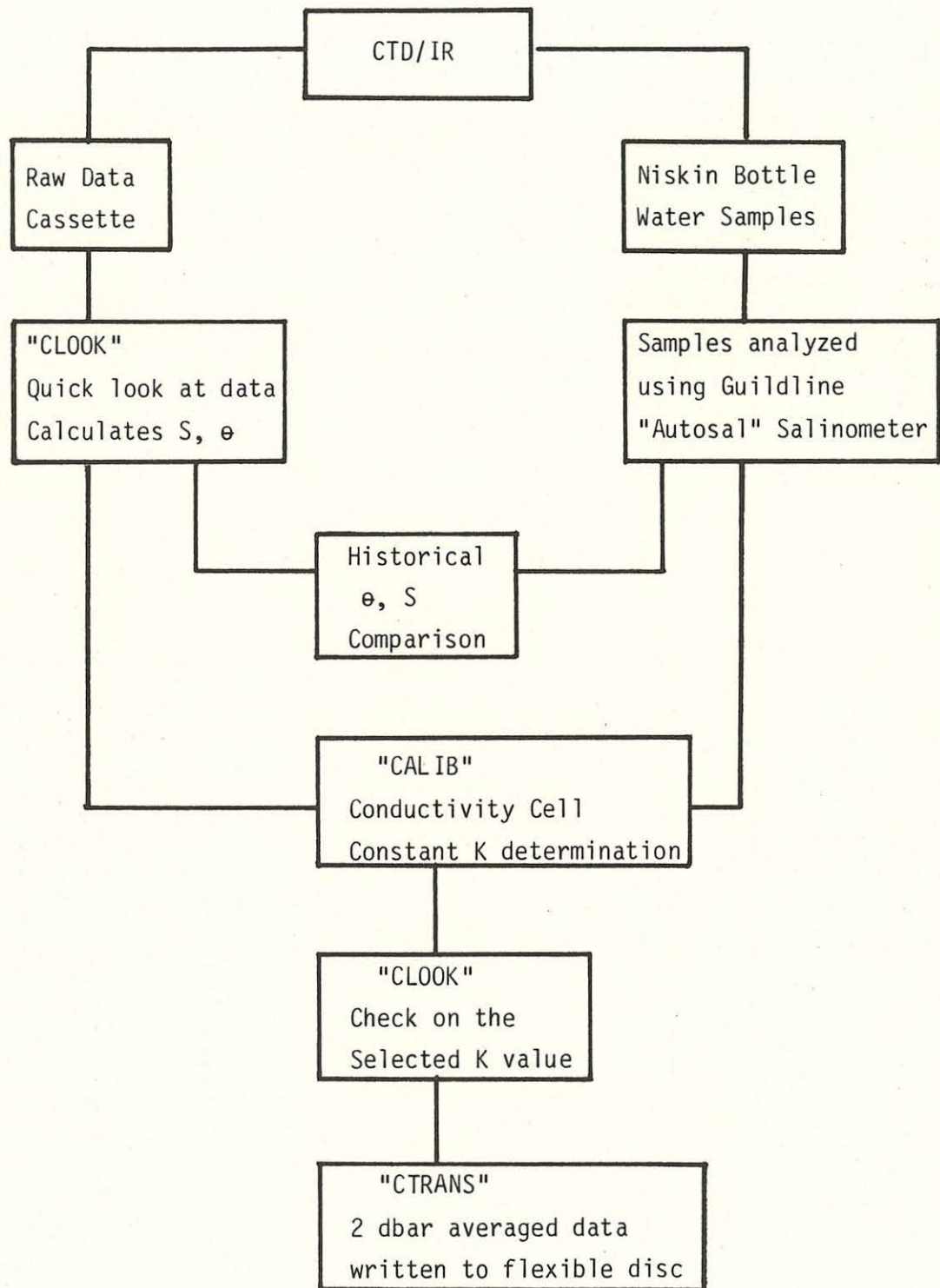

Figure 10. A flow chart of the procedure for processing the CTD/IR data.

Provisions within this program allow for these variables to be either printed or plotted. No sensor time-response are applied in CLOOK, and normally only every 200th data record might be examined although the operator can choose start and stop records, and subsampling interval.

The salinity of the water samples collected at depth is determined using a Guildline "Autosal" Salinometer. The water sample salinities are first compared with Worthington and Metcalf (1961) historical  $\sigma$ -S data. The potential temperature taken from the previous computer output is used to obtain an average salinity value from Worthington and Metcalf. If the salinities agree within the uncertainties of the Worthington and Metcalf  $\sigma$ -S curve then the bottle sample is used in another comparison with the calculated CTD/IR salinity. This comparison is made using a program called CALIB (for calibration). If the calculated CTD salinities do not exactly agree with the water sample salinity, which is considered to be the true salinity, an adjustment is made to the CTD conductivity data. The adjustment is made by multiplying the conductivity values by a conductivity cell factor, K. The correct cell factor is determined for each station using the program CALIB. This program uses an iterative process in which K is adjusted until the calculated CTD salinities and bottle salinities are matched within reasonable limits, usually psu. Having calculated a value for K it is tested by applying it to the data using the CLOOK program. Once the operator is satisfied with the value of K the data is pressure averaged and stored on disc. The program which carries out this final stage of the preliminary data processing is called CTRANS (for CTD Transcription). Wild points are edited and CTRANS applies an additional correction to the pressure and conductivity data since their sensor response to sudden changes is considerably faster than the response time of the platinum temperature sensor. The recursive filter, which in effect slows down the conductivity and pressure sensors to match the temperature sensor, is described in Millard (1981). Having applied that correction the data is averaged over a two decibar pressure range (but operator selectable) and stored on a flexible disc for future processing.

A 5500 m CTD profile sampled at 3.91 Hz, and averaged to 2 dbar yields 2800 data records and three such profiles can be stored on a single 5.25 inch dual-sided double-density flexible disk.

## VI. CTD/IR USE AT SEA

This section of the report is intended as an at-sea guide for operators of the CTD/IR. By reading this section in conjunction with the introduction (section I) the mechanics of using the system should become clear.

Attached to the CTD is a Benthos Pinger, three Niskin water sampling bottles, two underwater switches, and a tripping mechanism. The Benthos Pinger is used in conjunction with a Precision Depth Recorder (PDR) to give a real time indication of the CTD/IR's position off the bottom. The sampling bottles collect a deep water salinity sample that is used to calibrate the CTD/IR conductivity measurements. One of the two underwater switches is externally wired to the CTD/IR so that it turns the CTD/IR on or off. The other switch is connected to the Benthos Pinger and is capable of changing the ping rate from one to two pings per second. The tripping mechanism is a messenger activated device which trips the sample bottles and the switches.

In order to help clarify the procedures of a CTD/IR station the sequence of events will be discussed next.

Prior to getting on station the CTD/IR should be completely assembled and ready for the next cast with the exception of turning the unit on and loading the tripping mechanism. As the ship approaches the next station one member of the watch should begin filling in a CTD/IR station log sheet (Appendix III). Once on station such information as position and depth of the water can be obtained from the Loran C and PDR respectively. Having obtained that information final preparations for the deployment can be made.

### A. Preparing the CTD/IR for Deployment

The CTD is lowered using the hydrowinch. Once the CTD is positioned near the rail the hydrowire can be attached to the instrument and the tripping mechanism loaded.



The following steps outline the procedures for preparing the CTD/IR for deployment. Figure 7 is intended to help clarify these procedures.

1. Attaching the Hydrowire
  - a. Remove the three wing nuts from the top of the tripping mechanism.
  - b. Pulling straight up remove the T shaped polyethylene piece from the tripping mechanism.
  - c. Insert the hydrowire termination through the resulting hole in the tripping mechanism and attach it to the top of the Miller swivel.
  - d. Replace the T shaped piece around the hydrowire and return the wing nuts to the "J" pins. The wing nuts should only be started on the J pins, do not tighten.
2. Close the vents and spigots on each Niskin bottle. (Turn vents (upper) clockwise till tight and pull spigots (lower) outward.)
3. Cock each Niskin bottle.
  - a. Take the long lanyard from the upper cap and feed it through the eye in the lanyard of the lower cap.
  - b. Pulling upward on the long lanyard with one hand tilt open the lower cap with the other.
  - c. With the lower cap ajar continue to pull upward on the long lanyard. At the same time tilt the upper cap open.
  - d. Pull the long lanyard all the way to the tripping mechanism.
  - e. Insert the eye in the end of the long lanyard into the slot in the tripping mechanism. Place it over the end of the J pin by depressing the spring loaded J pin. The Niskin bottle will remain cocked as long as the J pin is not depressed.
  - f. Repeat this procedure for the other two Niskin bottles.
4. Take the short lanyard from the Benthos switch labelled "pinger" and pull it upward toward the tripping mechanism. Take the small halyard clip on the end of the lanyard and snap it around the eye (not through the eye) of the long Niskin bottle lanyard between the small retaining ball and the tripping mechanism. The clip

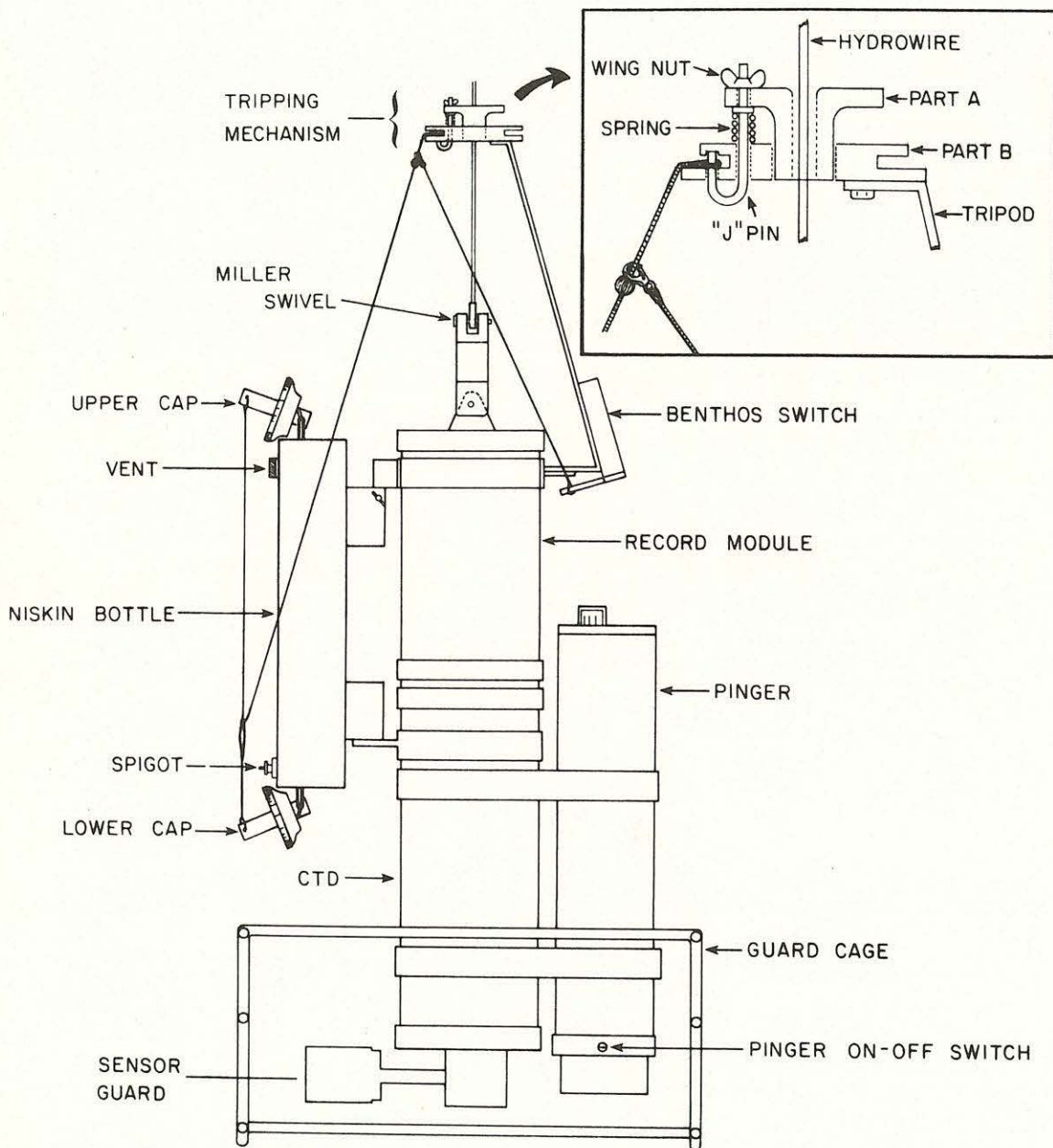

Figure 11. A schematic of the CTD/IR with the basic components of the in situ calibration system as they should appear prior to deployment. The insert shows the tripping mechanism and the proper arrangement of the lanyards from the Niskin bottles and Benthos switches.

will then come to rest against the ball. This switches the Benthos Pinger to a single ping per second rate.

5. CAUTION: The next step turns the CTD/IR on. The time that this occurs must be accurately recorded in the station log. Take the short lanyard from the Benthos switch labeled "CTD" and attach it at the same place and in the same manner as explained in step 4. Two halyard clips are, therefore, attached to the same Niskin bottle lanyard. This turns the CTD/IR on.
6. Remove the CTD/IR sensor guard by unscrewing the cap.
7. Turn the pinger on by turning a small screw-like switch near the projector end of the instrument. A screwdriver may be needed.

Once everything is ready the winch operator is signalled and the CTD/IR is lifted off the deck, swung out away from the hull and lowered into the water as quickly and gently as possible. The actual handling of the CTD during deployment will require at least two people at the rail. Having entered the water without any complications the CTD/IR is lowered to approximately 10 m and held there until further notification from the main lab.

#### B. Monitoring the PDR

Several individuals should be responsible for monitoring the PDR which will give an indication of the CTD/IR's distance off the bottom based on the time delay between the direct ping from the Benthos pinger and a ping reflected from the bottom.

Key PDR settings for our Sargasso Sea 5300 m stations are:

Scale: 750 m

Scale lines: Run

Paper feed: (C, continuous)

All switches in the receive mode (toward the operator)

Program length: 8

The other PDR settings are variable depending on the particular PDR.

An example of the type of output the PDR will display is shown in Figure 8. As can be seen there are a number of crossing lines. The cross-overs must be properly interpreted in order to know where the

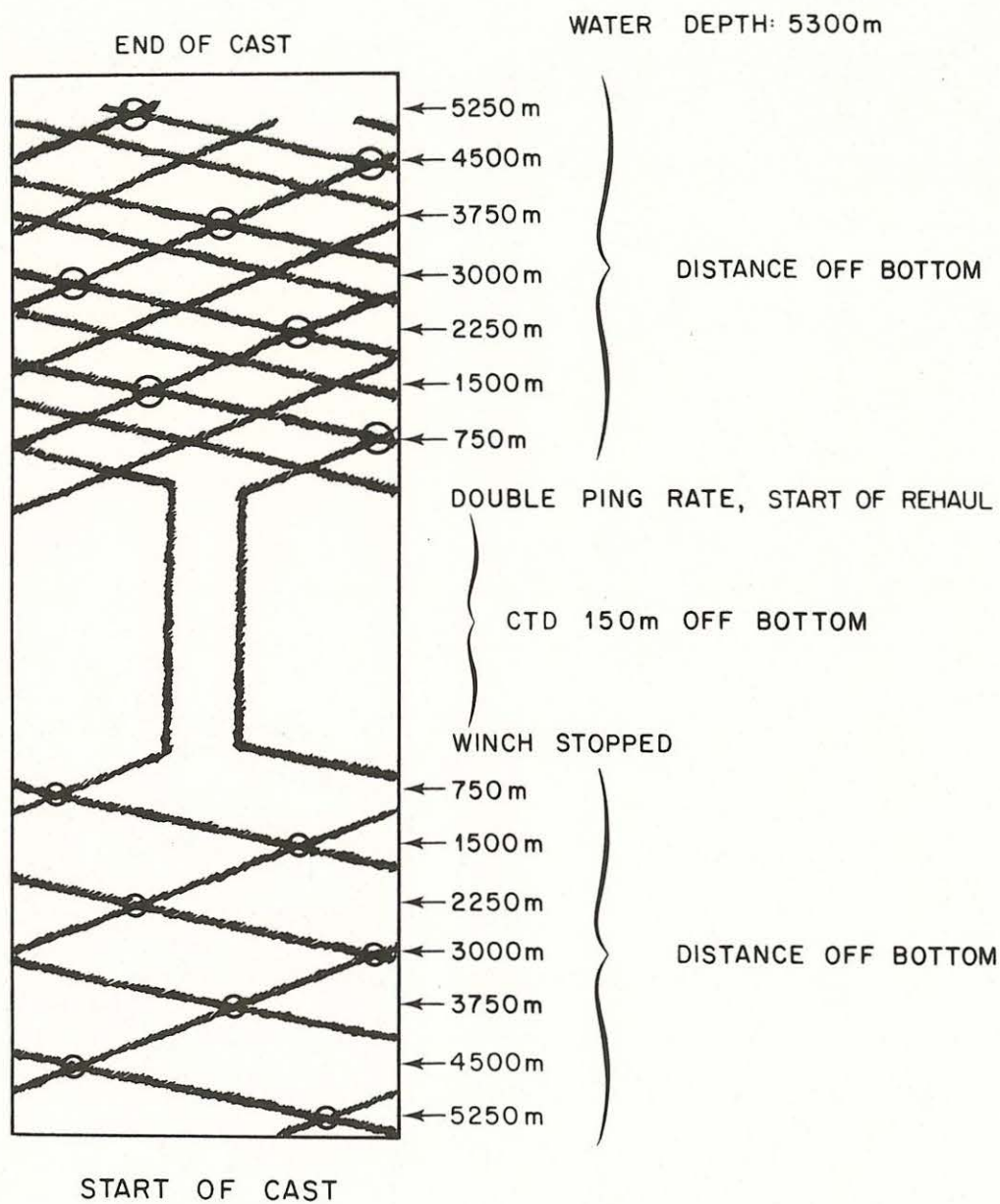

Figure 12. An example of the PDR output associated with a deep water (5300 m) CTD/IR station.

instrument is above the bottom. The cross-overs occur at intervals of approximately 750 m from the bottom. For example, if the water depth is 5300 m cross-overs will occur when the CTD/IR is:

Distance from the Bottom	Distance from the Surface
5250 m	50 m
4500 m	800 m
3750 m	1550 m
3000 m	2300 m
2250 m	3050 m
1500 m	3800 m
750 m	4550 m
0 m (on the bottom)	5300 m

The first cross-over will, therefore, occur when the CTD is only 50 meters from the surface. In that instance the first cross-over may be difficult to detect. To insure the correct labelling of the first cross-over the water depth must be known. Many times comparisons have to be made with the meter wheel readings. For example one would know immediately that the first cross-over was missed if in the earlier example 800 m of wire had been paid out before a cross-over became visible.

Assuming the PDR is operating satisfactorily and the meter wheel is zeroed, the winch operator should be notified to commence lowering at approximately 60 m/min. It is important that the PDR be monitored throughout the CTD cast in the event that the meter wheel is incorrect or there is a large wire angle.

After the 750 m off the bottom cross-over the two traces should never be allowed to cross, for if they do the instrument has struck the bottom and extensive damage may occur. As the two traces approach (below the 750 m off the bottom crossing) the distance between the two can be interpreted directly as the CTD/IR distance from the bottom.<sup>+</sup> Scale

---

<sup>+</sup> The 2216 Pinger has a "missed ping" option to help identify the lowest 750 m interval; see the Benthos Operation manual for the 2216 Pinger to learn to how to use this feature.

lines on the PDR output are 50 m apart with the PDR scale set at 750 m. When the winch is directed to stop, the two traces should remain the same distance apart as shown in figure 8. If they begin to approach and look as if they might cross the winch should be directed to haul in some wire.

Next, a messenger should be dropped in order to trip the sample bottles and switches. This can be done either after the CTD/IR is near the bottom or during the lowering such that the messenger reaches the tripping mechanism a short time after the CTD/IR has reached its maximum depth. Based on the time the messenger was released and the average rate of descent (250 m/min) an estimate of the time it will take to reach the CTD/IR can be made. When the messenger hits the tripping mechanism the water sample bottles close and the switches are tripped. One switch will turn the CTD/IR off thus saving battery power and the other switch will change the ping rate of the pinger to two pings/sec. The time that this occurs should be recorded in the log since it is the time the water samples were taken. For this reason the PDR should be monitored closely in order to detect the change in ping rate. At this time the PDR will show twice as many traces due to the increase in the ping rate. Close attention must be paid to the PDR in order to avoid any confusion during the rehaul. As soon as the double ping rate is detected the winch operator can be notified to begin hauling in the CTD/IR at 60 m/min. When the CTD/IR is within 100 m of the surface the winch operator should be informed to slow the hauling to 30 m/min. At this time a couple of people should be at the rail watching for the CTD/IR. They should be prepared to tell the winch operator the moment the CTD/IR comes in sight and the instant it breaks the surface. The CTD/IR is then brought on board and secured. The pinger should be turned off and the sensor guard replaced.

### C. Water Samples

Water samples should be taken as soon as possible from the Niskin bottles. The procedure is outlined below.

For each Niskin bottle:

1. Open only the spigot and check to see if the Niskin bottle is

leaking. If there is any indication of a leaky bottle note it in the log.

2. Take three bottle samples from each Niskin bottle.
  - a. Rinse the sample bottles three times with a small amount of water from the Niskin.
  - b. Fill the sample bottles only to the shoulder of the bottle leaving some air near the cap.
  - c. Cap tightly.

Once all the water samples have been drawn the CTD/IR should be rinsed with fresh water. The sensors should also be rinsed and the sensor guard replaced.

#### D. Turning a Record Module Around

The CTD/IR can only operate for eight hours before the batteries need to be recharged. Therefore, it is necessary to keep a running total of the number of hours a particular record module has been in operation and to record that information at the bottom of the CTD/IR station log sheet. At least three deep water stations can be completed before the record module will need to be removed and recharged. There are two record modules which will be used alternately. Upon completion of the third station using the same record module it should be removed and replaced by a fully charged unit. This operation should be conducted in a protected dry environment. The procedures for removing, recharging and replacing a record module are outlined below.

1. Removal of a Record Module
  - a. Disconnect the hydrowire from the swivel.
  - b. Remove the three Niskin bottles.
  - c. Disconnect the cable between the CTD switch and the CTD/IR at the top end cap of the record module.
  - d. Cover the exposed CTD/IR connector with a dummy plug.
  - e. Disconnect the cables between the pinger switch and the Benthos Pinger at the pinger.

- f. Remove the tripod by undoing the three bolts that fasten it to the record module.
  - g. Remove the Marmon clamp that fastens the record module to the main CTD.
  - h. Lifting straight up remove the record module.  
CAUTION: There is an internal cable that becomes visible after lifting the record module about four inches. It must be disconnected from the main CTD before the record module can be removed completely.
  - i. Place a red plastic protective cover provided by NBIS on the top of the main CTD and on the bottom of the record module in order to protect all O-Ring surfaces.
  - j. Secure the record module.
2. Recharging a Record Module
    - a. Connect the Charger/Controller to a suitable main power source.
    - b. Connect a cable from the "UWU" (underwater unit) jack on the Charger/Controller to the two pin connector on the top end cap of the record module.
    - c. Place the Charger/Controller in the "charge" mode of operation.
    - d. Turn the Charger/Controller on.

The record module does not have to be connected to the CTD in order to be charged. Total charging time is approximately thirteen hours.

3. Cassette Installation

Once the record module is fully charged a fresh cassette can be installed. The procedures for installing a new cassette are outlined below. This operation requires the record module to be separated from the CTD. The procedure for removing a record module is described in section VI, D1.

- a. Remove the splash guard from the lower end of the record module by withdrawing the retaining pins.



- b. Erase a fresh tape using the bulk tape eraser: the quality of the tape can be checked by reading the tape with the Sea Data 12A Reader. If the 12A reader indicates that there are any short records, low signals, or parity errors the cassette should be erased again. These problems will not exist if the cassette has been properly erased.
  - c. Write on the cassette the date and time, an ID, i.e. LOTUS 10 (which means the 10th tape from the LOTUS experiment), and the number of the record module it is being installed in. Log this information on the front cover of the CTD log book.
  - d. Advance the tape past the clear leader with the supply side to the right.
  - e. Install the fresh cassette by rotating the head release handle away from the transport assembly, sliding the top of the cassette under the retainer spring, and pushing the cassette into place, making sure the tape is properly positioned between the capstan and the pinch roller. The head release handle can then be returned to the closed position.
  - f. Do not replace the splash guard until the tape transport is checked during the replacement of the record module (next section).
4. Replacement of a Record Module
- a. With a fresh record module (charged battery and new cassette) connect the internal cable from the record module to the CTD.
  - b. Check the tape transport by running the CTD for one minute while observing the tape drive. The CTD can be turned on by shorting the two pin connector on the top end plate of the record module. A shorting plug is available for this operation. Fill in a CTD/IR log sheet for this short operating period.
  - c. Disconnect the internal cable from the CTD.
  - d. Return the splash guard to the record module.

- e. Purge the record module with freon through the splash guard retainer pin holes.
- f. Reinsert the splash guard pins.
- g. Clean the O-Ring grooves on the main CTD.
- h. Install new, lightly greased O-Rings.
- i. Clean the O-Ring surface of the record module.
- j. Reconnect the internal cable between the record module and the CTD.
- k. Join the record module and the main CTD taking care to align the two units so as not to bind up the mating surfaces. Align the tabs for the Niskin bottle on the record module with those on the CTD.
- l. Replace the Marmon clamp with 60 in-lbs of torque on the bolt.\*
- m. Replace the tripod, making sure the switches are in the same position with respect to the pinger so that the cables will reach.
- n. Replace the Niskin bottles.
- o. Connect the cable from the CTD switch to the CTD/IR.
- p. Connect the two cables from the pinger switch to the pinger making sure that the connector marked "1" is placed on pin 1 of the pinger.
- q. Connect the hydrowire to the swivel.

---

\* CAUTION \*

Marmon clamps have been known to crack in the region of the T bolt where the steel has been rolled. Careful inspection of every clamp, whether it has been removed or not, is essential. Failure to detect a faulty clamp could result in the loss of the instrument.

## APPENDIX I

## Modifications to the NBIS MK IIIB CTD.

The following is a list of modifications made to the MK IIIB CTD in order to permit battery operation and internal recording. The list is taken directly from the NBIS CTD/IR manual.

Backplane Wiring

1. Eight interconnections were made between the CTD backplane and the Recorder Module electronics as shown in C1001-0063A.
2. A 10 K ohm resistor was installed 0502 to 0514 to bypass the (unused) Oxygen Interface Card permitting data recirculation.
3. 1212 to Z1 cathode connection was removed to allow proper on/off control by Recorder Module electronics. Z1 is the stud-mounted component located on the CTD upper rack end.

Circuit Cards

1. Power Supply Card: R1 and CR1 removed and jumpered to allow operation with the reduced voltage available from the Nickel-Cadmium battery pack,
2. Signal Generator Card: Frame jumper installed to provide desired recording rate.
3. TTY Formatter and FSK Modulator Card: Added diode OR Gate to permit introduction of record clock from Memodyne Formatter in Recorder Module. Set Telemetry record length DIP Switch to 8 Bytes.
4. Adaptive Sampling Card: Power-up RC network (4.7 meg/2.2  $\mu$ F) installed at 17 pin 3 and isolated from backplane by cutting track.

APPENDIX II  
Addition of a File Gap

A slight modification to the head driver board of the Sea Data Tape Transport circuitry allowed for the addition of a file gap to the data stream. The modifications will be outlined below:

1. Resistor R1 (100 k) of the Head Driver Board was replaced by a 1 M  $\Omega$  resistor.
2. The wire from pin 32 of the Head Driver Board to the bus connecting pins 35 was removed.
3. A 3.3  $\mu$ f capacitor was connected from pin 32 of the Head Driver Board to pin 34 of the Head Driver Board.

With these modifications each time the instrument was turned on a file gap of approximately four seconds occurred before the instrument began recording data. By varying the size of the resistor and capacitor installed the length of the gap can be adjusted. However, depending on the requirements of the tape reader the file gap has to be of sufficient length so that the reader can detect it as such. In the case of the Sea Data 12A reader used to read the cassettes generated by our CTD/IR a gap of at least 300 steps was required.

## APPENDIX III

## INTERNALLY-RECORDING CTD STATION LOG

Ship/Cruise \_\_\_\_\_ CTD Station # \_\_\_\_\_  
 Day/Month/Year \_\_\_\_\_ Latitude \_\_\_\_\_  
 Instrument/Recorder # 001/ 01 02 \_\_\_\_\_ Longitude \_\_\_\_\_  
 Cassette ID \_\_\_\_\_ Loran (Time Diff.) X = \_\_\_\_\_  
 Recording Interval 1/2/4/8 Hz \_\_\_\_\_ Y = \_\_\_\_\_  
 Depth (GDR) \_\_\_\_\_ Transducer \_\_\_\_\_ Profile by \_\_\_\_\_  
 \_\_\_\_\_ Corr. \_\_\_\_\_ Recorder/Observer \_\_\_\_\_  
 Matthews Area/Corr. \_\_\_\_\_ Wind Speed \_\_\_\_\_  
 Corr. Depth \_\_\_\_\_ Wind Direction \_\_\_\_\_  
 Sea State \_\_\_\_\_  
 Corresponding XBTs \_\_\_\_\_

Time On (shorting plug installed) \_\_\_\_\_  
 Sensor Guard Off \_\_\_\_\_ On \_\_\_\_\_  
 Pinger On \_\_\_\_\_ Off \_\_\_\_\_  
 No. of YoYo's (see attached sheet) \_\_\_\_\_

Niskin Bottle #	Ready	Water Sample Bottle #	Comments

	Time EST/EDT/UTC	Comments
In the Water		
Start of Drop		Lat. _____ Long. _____
Messenger Drop		
Max. Depth		
Wire out _____ m		Lat. _____
PDR _____ m		Long. _____
Double Ping		
Time Off		
Surface		
On Deck		

Elapsed Time \_\_\_\_\_ Pinger \_\_\_\_\_ Tape \_\_\_\_\_ Profile \_\_\_\_\_  
 Total Elapsed Time \_\_\_\_\_ Installed Cassette \_\_\_\_\_ Pinger \_\_\_\_\_  
 Comments: \_\_\_\_\_  
 \_\_\_\_\_  
 \_\_\_\_\_

## References

- Brown, N. L. and G. K. Morrison (1978). WHOI/Brown conductivity, temperature and depth microprofiler. Woods Hole Oceanographic Institution Technical Report, WHOI Ref. 78-23.
- Fofonoff, N. P., S. P. Hayes and R. C. Millard (1974). WHOI/Brown Microprofiler: Methods of Calibration and Data Handling. Woods Hole Oceanographic Institution, WHOI Ref. 74-89.
- Fofonoff, N. P. (1981). Algorithms for oceanographic computations, SCOR Working Group Report.
- Millard, R. C., Jr. (1981). CTD Calibration and Data Processing Techniques Using the 1978 Practical Salinity Scale.
- Neil Brown Instrument Systems, Inc. (1980). Internal Recording CTD, CTD/IR Manual.
- Worthington, L. V. and W. G. Metcalf (1961). The relationship between potential temperature and salinity in deep Atlantic water. Rapp. et. P. V. Conseil Perm. Exp. de la Mer, Vol. 149, 122-128.

MANDATORY DISTRIBUTION LIST

FOR UNCLASSIFIED TECHNICAL REPORTS, REPRINTS, AND FINAL REPORTS  
PUBLISHED BY OCEANOGRAPHIC CONTRACTORS  
OF THE OCEAN SCIENCE AND TECHNOLOGY DIVISION  
OF THE OFFICE OF NAVAL RESEARCH

(REVISED NOVEMBER 1978)

- 1 Deputy Under Secretary of Defense  
(Research and Advanced Technology)  
Military Assistant for Environmental Science  
Room 3D129  
Washington, D.C. 20301
- Office of Naval Research  
800 North Quincy Street  
Arlington, VA 22217
- 3 ATTN: Code 483  
1 ATTN: Code 460  
2 ATTN: 102B
- 1 CDR Joe Spigai, (USN)  
ONR Representative  
Woods Hole Oceanographic Inst.  
Woods Hole, MA 02543
- Commanding Officer  
Naval Research Laboratory  
Washington, D.C. 20375
- 6 ATTN: Library, Code 2627
- 12 Defense Technical Information Center  
Cameron Station  
Alexandria, VA 22314  
ATTN: DCA
- Commander  
Naval Oceanographic Office  
NSTL Station  
Bay St. Louis, MS 39522
- 1 ATTN: Code 8100  
1 ATTN: Code 6000  
1 ATTN: Code 3300
- 1 NODC/NOAA  
Code D781  
Wisconsin Avenue, N.W.  
Washington, D.C. 20235
- 1 Mr. Michael H. Kelly  
Administrative Contracting Officer  
Department of the Navy  
Office of Naval Research  
Eastern/Central Regional Office  
Building 114, Section D  
666 Summer Street  
Boston, MA 02210

REPORT DOCUMENTATION PAGE		READ INSTRUCTIONS BEFORE COMPLETING FORM
1. REPORT NUMBER WHOI-81-74	2. GOVT ACCESSION NO.	3. RECIPIENT'S CATALOG NUMBER
4. TITLE (and Subtitle)  MECHANICAL AND OPERATIONAL DETAILS OF A NEIL BROWN INSTRUMENT SYSTEMS INTERNALLY RECORDING CONDUCTIVITY, TEMPERATURE, DEPTH (CTD) PROFILER		5. TYPE OF REPORT & PERIOD COVERED  Technical
		6. PERFORMING ORG. REPORT NUMBER
7. AUTHOR(s)  Richard P. Trask		8. CONTRACT OR GRANT NUMBER(s)  N00014-76-C-0197;
9. PERFORMING ORGANIZATION NAME AND ADDRESS  Woods Hole Oceanographic Institution Woods Hole, Massachusetts 02543		10. PROGRAM ELEMENT, PROJECT, TASK AREA & WORK UNIT NUMBERS  NR 083-400
11. CONTROLLING OFFICE NAME AND ADDRESS  NORDA Bay St. Louis, MS 39529		12. REPORT DATE  September 1981
		13. NUMBER OF PAGES  41
14. MONITORING AGENCY NAME & ADDRESS (if different from Controlling Office)		15. SECURITY CLASS. (of this report)  Unclassified
		15a. DECLASSIFICATION/DOWNGRADING SCHEDULE
16. DISTRIBUTION STATEMENT (of this Report)  Approved for public release; distribution unlimited.		
17. DISTRIBUTION STATEMENT (of the abstract entered in Block 20, if different from Report)		
18. SUPPLEMENTARY NOTES  This report should be cited as: Woods Hole Oceanog. Inst. Tech. Rept. WHOI-81-74.		
19. KEY WORDS (Continue on reverse side if necessary and identify by block number)  1. Internally recording CTD 2. Conductivity and temperature measurements 3. In situ calibration system		
20. ABSTRACT (Continue on reverse side if necessary and identify by block number)  The purpose of this report is to discuss the use of a Neil Brown Instrument Systems internal recording CTD. The components of the instrument are described along with the advantages and disadvantages of the internal recording system. Calibration of the pressure and temperature sensors in the laboratory and the method used for in situ calibration of the conductivity sensor is described. A step by step description of the use of the CTD/IR at sea is also included.		



<p>Woods Hole Oceanographic Institution WHOI-81-74</p> <p>MECHANICAL AND OPERATIONAL DETAILS OF A NEIL BROWN INSTRUMENT SYSTEMS INTERNALLY RECORDING CONDUCTIVITY, TEMPERATURE, DEPTH (CTD) PROFILER by Richard P. Trask. 41 pages. September 1981. Prepared for the Office of Naval Research under Contract N00014-76-C-0197; NR 083-400.</p> <p>The purpose of this report is to discuss the use of a Neil Brown Instrument Systems internal recording CTD. The components of the instrument are described along with the advantages and disadvantages of the internal recording system. Calibration of the pressure and temperature sensors in the laboratory and the method used for in situ calibration of the conductivity sensor is described. A step by step description of the use of the CTD/IR at sea is also included.</p>	<p>Woods Hole Oceanographic Institution WHOI-81-74</p> <p>MECHANICAL AND OPERATIONAL DETAILS OF A NEIL BROWN INSTRUMENT SYSTEMS INTERNALLY RECORDING CONDUCTIVITY, TEMPERATURE, DEPTH (CTD) PROFILER by Richard P. Trask. 41 pages. September 1981. Prepared for the Office of Naval Research under Contract N00014-76-C-0197; NR 083-400.</p> <p>The purpose of this report is to discuss the use of a Neil Brown Instrument Systems internal recording CTD. The components of the instrument are described along with the advantages and disadvantages of the internal recording system. Calibration of the pressure and temperature sensors in the laboratory and the method used for in situ calibration of the conductivity sensor is described. A step by step description of the use of the CTD/IR at sea is also included.</p>	<p>1. Internally recording CTD</p> <p>2. Conductivity and temperature measurements.</p> <p>3. In situ calibration system</p> <p>I. Trask, Richard P.</p> <p>II. N00014-76-C-0197; NR 083-400.</p> <p>This card is UNCLASSIFIED</p>	<p>1. Internally recording CTD</p> <p>2. Conductivity and temperature measurements.</p> <p>3. In situ calibration system</p> <p>I. Trask, Richard P.</p> <p>II. N00014-76-C-0197; NR 083-400.</p> <p>This card is UNCLASSIFIED</p>	<p>1. Internally recording CTD</p> <p>2. Conductivity and temperature measurements.</p> <p>3. In situ calibration system</p> <p>I. Trask, Richard P.</p> <p>II. N00014-76-C-0197; NR 083-400.</p> <p>This card is UNCLASSIFIED</p>
<p>Woods Hole Oceanographic Institution WHOI-81-74</p> <p>MECHANICAL AND OPERATIONAL DETAILS OF A NEIL BROWN INSTRUMENT SYSTEMS INTERNALLY RECORDING CONDUCTIVITY, TEMPERATURE, DEPTH (CTD) PROFILER by Richard P. Trask. 41 pages. September 1981. Prepared for the Office of Naval Research under Contract N00014-76-C-0197; NR 083-400.</p> <p>The purpose of this report is to discuss the use of a Neil Brown Instrument Systems internal recording CTD. The components of the instrument are described along with the advantages and disadvantages of the internal recording system. Calibration of the pressure and temperature sensors in the laboratory and the method used for in situ calibration of the conductivity sensor is described. A step by step description of the use of the CTD/IR at sea is also included.</p>	<p>Woods Hole Oceanographic Institution WHOI-81-74</p> <p>MECHANICAL AND OPERATIONAL DETAILS OF A NEIL BROWN INSTRUMENT SYSTEMS INTERNALLY RECORDING CONDUCTIVITY, TEMPERATURE, DEPTH (CTD) PROFILER by Richard P. Trask. 41 pages. September 1981. Prepared for the Office of Naval Research under Contract N00014-76-C-0197; NR 083-400.</p> <p>The purpose of this report is to discuss the use of a Neil Brown Instrument Systems internal recording CTD. The components of the instrument are described along with the advantages and disadvantages of the internal recording system. Calibration of the pressure and temperature sensors in the laboratory and the method used for in situ calibration of the conductivity sensor is described. A step by step description of the use of the CTD/IR at sea is also included.</p>	<p>1. Internally recording CTD</p> <p>2. Conductivity and temperature measurements.</p> <p>3. In situ calibration system</p> <p>I. Trask, Richard P.</p> <p>II. N00014-76-C-0197; NR 083-400.</p> <p>This card is UNCLASSIFIED</p>	<p>1. Internally recording CTD</p> <p>2. Conductivity and temperature measurements.</p> <p>3. In situ calibration system</p> <p>I. Trask, Richard P.</p> <p>II. N00014-76-C-0197; NR 083-400.</p> <p>This card is UNCLASSIFIED</p>	<p>1. Internally recording CTD</p> <p>2. Conductivity and temperature measurements.</p> <p>3. In situ calibration system</p> <p>I. Trask, Richard P.</p> <p>II. N00014-76-C-0197; NR 083-400.</p> <p>This card is UNCLASSIFIED</p>
<p>Woods Hole Oceanographic Institution WHOI-81-74</p> <p>MECHANICAL AND OPERATIONAL DETAILS OF A NEIL BROWN INSTRUMENT SYSTEMS INTERNALLY RECORDING CONDUCTIVITY, TEMPERATURE, DEPTH (CTD) PROFILER by Richard P. Trask. 41 pages. September 1981. Prepared for the Office of Naval Research under Contract N00014-76-C-0197; NR 083-400.</p> <p>The purpose of this report is to discuss the use of a Neil Brown Instrument Systems internal recording CTD. The components of the instrument are described along with the advantages and disadvantages of the internal recording system. Calibration of the pressure and temperature sensors in the laboratory and the method used for in situ calibration of the conductivity sensor is described. A step by step description of the use of the CTD/IR at sea is also included.</p>	<p>Woods Hole Oceanographic Institution WHOI-81-74</p> <p>MECHANICAL AND OPERATIONAL DETAILS OF A NEIL BROWN INSTRUMENT SYSTEMS INTERNALLY RECORDING CONDUCTIVITY, TEMPERATURE, DEPTH (CTD) PROFILER by Richard P. Trask. 41 pages. September 1981. Prepared for the Office of Naval Research under Contract N00014-76-C-0197; NR 083-400.</p> <p>The purpose of this report is to discuss the use of a Neil Brown Instrument Systems internal recording CTD. The components of the instrument are described along with the advantages and disadvantages of the internal recording system. Calibration of the pressure and temperature sensors in the laboratory and the method used for in situ calibration of the conductivity sensor is described. A step by step description of the use of the CTD/IR at sea is also included.</p>	<p>1. Internally recording CTD</p> <p>2. Conductivity and temperature measurements.</p> <p>3. In situ calibration system</p> <p>I. Trask, Richard P.</p> <p>II. N00014-76-C-0197; NR 083-400.</p> <p>This card is UNCLASSIFIED</p>	<p>1. Internally recording CTD</p> <p>2. Conductivity and temperature measurements.</p> <p>3. In situ calibration system</p> <p>I. Trask, Richard P.</p> <p>II. N00014-76-C-0197; NR 083-400.</p> <p>This card is UNCLASSIFIED</p>	<p>1. Internally recording CTD</p> <p>2. Conductivity and temperature measurements.</p> <p>3. In situ calibration system</p> <p>I. Trask, Richard P.</p> <p>II. N00014-76-C-0197; NR 083-400.</p> <p>This card is UNCLASSIFIED</p>