

Woods Hole Oceanographic Institution



Testing and Evaluation of SURLYN Foam and SPECTRA Fiber Ropes for Buoy Systems Applications

by

H. Berteaux, A. Bocconcelli, M. Gould, S. Kery

August 1988

Technical Report

Funding was provided by the Office of Naval Research under contract
Number N00014-84-C-0134.

Approved for public release; distribution unlimited.

DOCUMENT
LIBRARY

Woods Hole Oceanographic
Institution

WHOI-88-32

**Testing and Evaluation of
SURLYN Foam and SPECTRA Fiber Ropes
for Buoy Systems Applications**

by

H. Berteaux, A. Bocconcelli, M. Gould, S. Kery

Ocean Structures & Moorings Laboratory
Ocean Engineering Department
Woods Hole Oceanographic Institution
Woods Hole, Massachusetts 02543

August 1988

Technical Report

Funding was provided by the Office of Naval Research
through contract Number N00014-84-C-0134.

Reproduction in whole or in part is permitted for any purpose of the
United States Government. This report should be cited as:
Woods Hole Oceanog. Inst. Tech. Rept., WHOI-88-32.

Approved for publication; distribution unlimited.

Approved for Distribution:



Albert J. Williams III, Chairman
Department of Ocean Engineering



TESTING AND EVALUATION
of
SURLYN FOAM AND SPECTRA FIBER ROPES
for
BUOY SYSTEMS APPLICATIONS

Authors:

H. Berteaux, A. Bocconcelli; M. Gould, S. Kery

August 9, 1988

Ocean Structures & Moorings Laboratory
Ocean Engineering Department
WOODS HOLE OCEANOGRAPHIC INSTITUTION
Woods Hole, Massachusetts 02543

ACKNOWLEDGEMENTS

The authors want to acknowledge the Gilman Corporation and the Allied Chemical Corporation for providing the samples of buoyancy material and Spectra Fiber ropes which were tested and evaluated as described in the report.

The technical support of P.O'Malley in the planning and performance of the tests was of great help.

We thank L. Moore for her contribution in preparing the report manuscript.

The work described in this report was performed under ONR contract number N00014-84-C-0134, NR083-400, and with the help of an Allied Chemical grant, Purchase Order number 61-79791.

Contents

1	SURLYN FOAM TEST REPORT	3
1.1	INTRODUCTION	4
1.2	PURPOSE	4
1.3	DESCRIPTION OF SAMPLES	4
1.4	TEST PROCEDURE	7
1.5	CONCLUSIONS	13
1.6	APPENDIX A - Good Little Buoys	14
1.7	APPENDIX B - Surlyn Product Guide	15
2	CREEP TESTS OF SPECTRA ROPES	16
2.1	TEST OBJECTIVE	17
2.2	TEST SET UP	17
2.3	ROPE CONSTRUCTIONS TESTED	17
2.4	ROPE TEST SAMPLES	19
2.4.1	The test samples were numbered as follows:	19
2.4.2	Test Loads	19
2.4.3	Actual Loads (as measured in sea water)	19
2.5	TEST SCHEDULE	19
2.6	FIRST LOADING STRESS VS. STRAIN CURVE	20
2.7	CREEP TEST RESULTS	24
2.7.1	First day loading	24
2.7.2	Subsequent testing	24
2.7.3	Permanent elongation	29
2.8	CONCLUSIONS	29

Chapter 1

SURLYN FOAM TEST REPORT

by Alessandro Bocconcelli and Sean Kery

1.1 INTRODUCTION

Surlyn ionomer resins are thermoplastic polymers produced by DuPont that can be molded, compressed, extruded and foamed into different shapes as needed. Foamed Surlyn is well suited for marine applications since it offers low-weight density, toughness, durability and excellent resistance to environmental agents, e.g. radiation, salt, waves, etc.

The Gilman Corporation (Gilman, CT) has been producing Surlyn foam for several years under the trademark name of Softlite Ionomer Foam. Navigational buoys and fenders made of Softlite foam are used successfully by the US Coast Guard and the US Navy.

1.2 PURPOSE

A typical oceanographic buoy must satisfy some basic requirements as such:

- Provide buoyancy to keep the oceanographic mooring in tension and to keep it from submerging under strong currents.
- Provide protected payload space to house data recording and transmitting equipment, batteries, etc.
- Be a stable platform for meteorological sensors.

To facilitate transportation and deployment, weight and dimension of the buoy must be compatible with the space and lifting equipment available on research vessels.

Deployment time at sea is sometimes longer than one year, during which the buoy will experience the harshness of the marine environment. Design and construction must insure that the buoy can withstand these environmental forces with minimal structural damage and limited loss of buoyancy.

When the decision was made to build a prototype surface buoy with increased payload and reserved buoyancy, Surlyn foam was chosen over other materials (fiberglass, Kevlar, aluminum) for its structural properties, good working record, cost and availability. However, more data in the following areas were needed to completely assess the performance of a large surface buoy built entirely with Surlyn foam:

- Water absorption rate under pressure
- Loss of buoyancy due to volume reduction
- Loss of buoyancy due to water absorption.

These tests were needed to select the proper foam density for a buoy with a displacement of 20,000 lbs. when fully immersed.

1.3 DESCRIPTION OF SAMPLES

Four samples of different shape, volume and density were provided by the Gilman Corporation for testing at the Woods Hole Oceanographic Institution (WHOI), by the Ocean Structures & Moorings Laboratory (OS&M Lab) (see Figure 1). All the samples were weighed and measured before wet testing. Their characteristics are shown in Table 1 below.

Table 1.1: Samples' Original Weights and Measurements

Sample ID	Length (inches)	O.D. (inches)	Volume (ft^3)	Weight (lbs)	Weight & Hardware (lbs)	Density (lbs/ft)
1	33.	25.7	9.8553	43.65	63.75	4.429
2	23.75	12.	1.548	8.38	14.3	5.413
3	29.75	9.56	1.233	12.5	12.5	10.138
4	13.625	37.94	8.904	32.0	32.0	3.594

- Sample #1 is a large grey cylinder with a 1 inch diameter steel through rod, end plates and eye nuts at each end. Total weight of the hardware is 20.1 lbs.
- Sample #2 is an assembly of 4 small dark grey cylinders mounted on a 3/4 inch steel rod with end plates and eye nuts. Weight of the hardware is 5.92 lbs. Each foam section has an average height of 6 inches.
- Sample #3 is a long blue cylinder with a central through hole (1.5 inch diameter) and no hardware attached.
- Sample #4 is a short, wide, red cylinder with a central through hole (1.5 inch diameter) and no hardware attached.

All four samples were built using the same manufacturing process in which a sheet of Softlite foam is heated and rolled up under tension in a cylindrical shape. Each new layer of foam heat-seals itself on the previous one giving the structure good longitudinal strength. The external surface of the foam body is then heat-treated, giving the external layer the consistency of a tough skin.

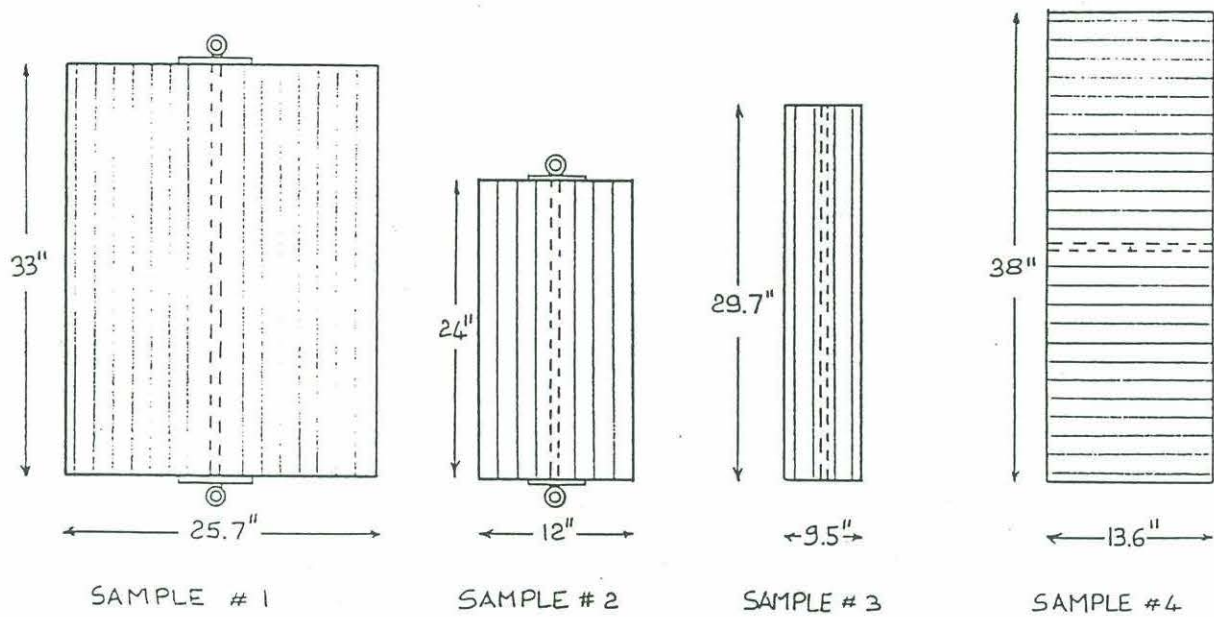

NOTE: SAMPLE INTERNAL LINES INDICATE FOAM CONCENTRIC LAYERS.
 DOTTED LINES REPRESENTS THRU HOLE

SCALE : 1" = 1"

DWG. 1984.13

Figure 1.1 Softlite Foam Test Samples

1.4 TEST PROCEDURE

a) MEASUREMENTS RATIONALE

Foams generally lose buoyancy when immersed in water. The following different factors which are inherent to the foam structure cause the buoyancy loss:

- **Flooding of some of the weaker cells at the foam sample surface.** In this case the surface cells might be weakened by action of environmental agents. The water absorbed in this way tends to leave the foam sample after it is pulled out of the water and dry stored. By measuring the weight before and after immersion the amount of water or weight gained can be roughly determined.
- **Flooding of cracks or interstices when layers of foam are not perfectly heat-sealed.** Water will easily fill the open spaces at an early stage of immersion. By increasing the depth the pressure can close the cracks and interstices preventing further flooding. Cracks and cuts might also be caused by improper handling or abrasion against rough surfaces. The water absorbed in this fashion will quickly leave the foam sample upon retrieval from the sea.
- **Buoyancy loss due to loss of volume.** When the foam sample is placed at depth the relative water pressure will act on its surface compressing the whole body of foam and reducing its volume. The ability of the foam to withstand pressure (bulk modulus) is dictated by strength, structure and flexibility of each cell wall and by the compressibility of the gas trapped inside the foam. There are 2 modes of buoyancy loss due to volume reduction. A plastic mode which is permanent and an elastic mode which recovers when the pressure is removed.

Thus to determine and quantify the different possible modes of buoyancy loss one must proceed with the following measurements.

- The initial weight in the air of the sample " W_i "
- The initial buoyancy of the sample " B_i ", which is measured at the surface. The initial buoyancy is defined as the difference between the immersed weight of the sinker, and the tension force in the line when the top of the sample is just immersed. " $B_i = SW - T$ ".
- The final buoyancy of the sample " B_f ", is the buoyancy at the surface measured as above.
- The final buoyancy of the sample at depth " B_d " which is measured as above with the line payed out until the top of the sample is at depth.
- The final weight of the sample in air " W_f " immediately after the sample is removed from the water.
- The final weight in air after the sample has completely stopped dripping " W_d ".

With the help of these measurements, buoyancy losses can be established as follows:

1. Total buoyancy loss " L_t " is then the difference between the initial immersed buoyancy and the immersed buoyancy at the end of the testing period.

$$L_t = B_i - B_f$$

2. Buoyancy loss due to water absorption "Lw" is the difference between the samples initial air weight "Wi" and its final air weight after it has stopped dripping "Wd"

$$Lw = Wi - Wd$$

3. Buoyancy loss due to the flooding of cracks and interstices "Lc" is the difference between the air weight when the sample is first pulled from the water "Wf" and the air weight after it has stopped dripping "Wd"

$$Lc = Wf - Wd$$

4. Buoyancy loss due to elastic deformation "Le" is the difference between the final buoyancy "Bf" and the buoyancy at depth "Bd"

$$Le = Bf - Bd$$

5. Buoyancy loss due to plastic deformation Lp is the difference between the total buoyancy loss "Lt" and the sum of the losses due to absorption "Lw" and the flooding of cracks "Lc"

$$Lp = Lt - (Lw + Lc)$$

b) TEST SET-UP

It was necessary to test the 4 foam samples at sea by hanging them from a floating platform; for the following reasons:

1. The maximum static pressure that affects the foam body of a surface buoy is 5 psi with the buoy fully submerged.
2. Size of samples. Significant samples of Softlite foam are too big to fit in the WHOI pressure vessel.
3. The floating platform canceled any depth variation due to tides.

The samples were carefully measured and weighed in air using two different scales (one mechanical and one load cell with a digital dial). The following parameters were determined:

- Volume of sample
- Density of sample
- Theoretical buoyancy
- Surface area to volume ratio
- Depressor weights necessary to fully submerge the foam samples.

The air and wet weight of each depressor weight and relative hardware was determined with the help of a crane car and precision load cell. The weight of the hardware necessary to connect weights and foam samples was also measured.

The buoyancy of a fully submerged foam sample in seawater is equal to the wet weight of the depressor and hardware less the tension in the line holding the depressor weight and the sample.

Each sample was connected to its depressor weight and lowered to a depth a few inches below the water surface. After five minutes in this position the tension was recorded and

the initial buoyancy was calculated. The hanging line was then paid out until the top of the sample reached a depth of five feet. The tension in the line was again recorded and subsequently the line was fastened to the floating platform. After 24 hours the line tension was measured again with the sample at 5 ft. depth, just below the surface and in the air.

The same procedure was then repeated for all 4 samples at a depth of 10 ft. and a time exposure of 24 hours. Data collected from these two pressure tests are shown in Table 2.

TEST I.D.	SAMPLE I.D.	INITIAL WEIGHT IN AIR W _i (Lbs)	INITIAL BUOYANCY AT SURFACE B _i (Lbs)	SINKER IMMERSED WEIGHT S _w (Lbs)	LINE TENSION T (Lbs)	FINAL BUOYANCY AT SURFACE BF (Lbs)	FINAL BUOYANCY AT DEPTH B _d (Lbs)	FINAL "WET" AIR WEIGHT W _f (Lbs)	FINAL "DRY" AIR WEIGHT W _d (Lbs)	TOTAL BUOYANCY LOSS		BUOYANCY LOSS DUE TO ABSORPTION		BUOYANCY LOSS DUE TO FLOODING		BUOYANCY LOSS DUE TO ELASTIC DEFORMATION		BUOYANCY LOSS DUE TO PLASTIC DEFORMATION	
										L _t (Lbs)	%	L _w (Lbs)	%	L _c (Lbs)	%	L _e (Lbs)	%	L _p (Lbs)	%
5 Ft 24 Hrs	#1 LG. BLACK	63.75	556.5	609.5	53	542.5	542	66	—	14	2.52	2.25	0.40	0	0	0.5	0.09	11.75	2.11
	#2 SM. BLACK	14.3	84	93	9	80.5	80.5	15	—	3.5	4.17	0.7	0.83	0	0	—	—	2.8	3.33
	#3 SM. BLUE	12.5	63	87	24	58.5	58.5	13	—	4.5	7.14	0.5	0.79	0	0	—	—	4	6.35
	#4 LG. RED	32.0	526	649	123	521	521	35.5	—	5	0.95	3.5	0.66	0	0	—	—	1.5	0.28
10 Ft 24 Hrs	#1 LG. BLACK	63.75	556.5	609.5	75	534.5	524	69	66	22	3.95	2.25	0.40	3	0.54	10.5	1.89	16.75	3.01
	#2 SM. BLACK	14.3	84	93	13.5	79.5	79.5	15.5	15	4.5	5.35	0.7	0.83	0.5	0.59	0	0	3.3	3.93
	#3 SM. BLUE	12.5	63	87	29.5	57.5	57	14	13	5.5	8.73	0.5	0.79	1	1.58	0.5	0.79	4	6.35
	#4 LG. RED	32.0	526	649	140	509	507	42.5	42	17	3.23	10	1.90	0.5	0.09	2	0.36	6.5	1.24
5 Ft 9 DAYS	#1 LG. BLACK	63.75	556.5	609.5	67	542.5	542.5	65	—	14	2.52	1.25	0.22	—	—	—	—	12.75	2.29
	#2 SM. BLACK	14.3	84	93	14	79.0	79.0	16	—	5	5.95	1.7	2.02	—	—	—	—	3.3	3.93
	#3 SM. BLUE	12.5	63	87	29.5	57.5	57.5	15.25	—	5.5	8.73	2.75	4.37	—	—	—	—	2.75	4.37
	#4 LG. RED	32.0	526	649	143	506	506	51.75	—	20	3.80	19.75	3.75	—	—	—	—	0.25	0.05
5 Ft 40 DAYS	#1 LG. BLACK	63.75	556.5	609.5	—	—	—	—	—	—	—	—	—	—	—	—	—	—	—
	#2 SM. BLACK	14.3	84	93	16	77	77	18	17	7	8.33	2.7	3.21	1	1.19	—	—	3.3	3.93
	#3 SM. BLUE	12.5	63	87	20	57	57	16.25	14.5	6	9.52	2.0	3.17	1.75	2.77	—	—	2.25	3.57
	#4 LG. RED	32.0	526	649	156	493	493	64	56	33	6.27	24	4.56	8	1.52	—	—	1	0.19

Table 1.2: Pressure Test Data

Subsequently, an endurance test was performed by suspending the foam samples at a depth of 5 ft. for longer periods of time (9 days and 40 days). Data from the endurance tests are shown in Tables 4 and 5. Unfortunately foam sample #1 broke loose during the 40 day endurance test and remains on the bottom at a depth of 55 ft. When this sample is recovered it will be evaluated for pressure effects at greater depths.

After one week of dry storage the 3 samples were weighted again and the following data were collected:

Table 1.3: Sample Test Data

Sample #	Initial Weight (lbs)	Weight after tests and Storage (lbs)	Water Retained (lbs)
2	14.3	17.	2.7
3	12.5	14.5	2.0
4	32.	56.	24.0

Table 1.4: Endurance Test (8 days)

#	SAMPLE I.D.	DRY WEIGHT AS PER 12/2/87 (Lbs)	DRY WEIGHT AS PER 12/10/87 (Lbs)	WATER ABSORBED IN 9 DAYS (Lbs)	ORIGINAL DRY WEIGHT (Lbs)	TOTAL WATER ABSORBED SINCE BEGINNING OF TESTING (Lbs)	PERCENTAGE OF ORIGINAL WEIGHT
1	LARGE BLACK FENDER	64	65	1	63.75	1.25	1.96
2	SMALL BLACK (4) SECTIONS	15	16	1	14.3	1.7	1.18
3	SMALL BLUE	13.25	15.25	2	12.5	2.75	22.0
4	LARGE RED	38.75	54.75	16	32	22.75	71.0

#	SAMPLE I.D.	INITIAL BUOYANCY (Lbs)	BUOYANCY AS PER 12/2/87 (Lbs)	BUOYANCY AS PER 12/10/87 (Lbs)	TOTAL BUOYANCY LOSS (Lbs)	BUOYANCY LOSS AS % OF ORIGINAL BUOYANCY	BUOYANCY LOSS DUE TO VOLUME REDUCTION (Lbs)	BUOYANCY LOSS DUE TO WATER ABSORPTION (Lbs)	%
1	LARGE BLACK FENDER	556.5	555.5	542.5	14	2.5	12.75	1.25	0.22
2	SMALL BLACK (4) SECTIONS	84	80.5	79.0	5	5.9	3.3	1.7	2.0
3	SMALL BLUE	63	61	57.5	6.5	10.3	3.75	2.75	4.3
4	LARGE RED	526	525	506	20	3.8	NONE	22.75	4.3

Table 1.5: Endurance Test (40 days)

#	SAMPLE I.D.	ORIGINAL DRY WEIGHT (Lbs)	DRY WEIGHT AFTER 9 DAYS IMMERSION AT 5' (Lbs)	DRY WEIGHT AFTER 40 DAYS IMMERSION AT 5' (Lbs)	TOTAL WATER ABSORBED	PERCENTAGE OF ORIGINAL WEIGHT (%)	REMARKS
1	LARGE BLACK FENDER	63.75	65	//	1.25	1.96	10 DAYS ONLY
2	SMALL (4) BLACK SECTIONS	14.3	16	18.0	3.7	25.8	
3	SMALL BLUE	12.5	15.25	16.25	3.75	30.0	
4	LARGE RED	32	54.75	64	32	100.0	

NOTE: -Percentages are based on initial dry weight and initial buoyancy

#	SAMPLE I.D.	DENSITY (Lbs/Ft ³)	INITIAL BUOYANCY (Lbs)	FINAL BUOYANCY (Lbs)	TOTAL BUOYANCY LOSS (Lbs)	%	BUOYANCY LOSS DUE TO VOLUME REDUCTION (Lbs)	%	BUOYANCY LOSS DUE TO WATER ABSORPTION (Lbs)	%	REMARKS
1	LARGE BLACK FENDER	4.43	556.5	542.5	14	2.5	12.75	2.29	1.25	0.22	10 DAYS ONLY
2	SMALL (4) BLACK SECTIONS	5.41	84	77	7	8.3	3.3	3.92	3.7	4.38	
3	SMALL BLUE	10.14	63	57	6	9.5	2.25	3.57	3.75	5.93	
4	LARGE RED	3.59	526	493	33	6.2	1	0.19	32	6.10	

NOTE: Buoyancy loss due to volume reduction = total loss of buoyancy at depth - total loss due to water absorption

1.5 CONCLUSIONS

Softlite foam offers many advantages as a buoyancy material for surface buoys because of the foam's following characteristics:

- Low weight/volume ratio
- Tough material which is resistant to the marine environment
- No painting needed since pigment is melted into the plastic during the manufacturing process.

The test results indicated that more factors besides density must be taken into consideration when choosing the right foam for a specific application. In the case of a surface buoy, some very important parameters are:

- Surface area to volume ratio
- Number of concentric layers of foam wound up to form the main body
- Outer skin conditions.

With reference to the first test (pressure), sample numbers 2 and 4 absorbed more water than numbers 1 and 3. Sample #4 had the lowest density and the highest surface area to volume ratio and, #2 had a low density and a low surface area to volume ratio. Buoyancy losses due to volume reduction seem somewhat contradictory. A possible explanation for the performance of #1 and #4 is that these samples have the highest number of foam layers and therefore were less compact and more resilient than the smaller samples.

The endurance tests show that foam with density values ranging from 4 to 5 p.c.f and a high number of layers should have a reasonable loss of buoyancy when deployed at sea for long periods of time. For future testing it would be ideal to deploy samples of the same size and volume but different densities.

1.6 APPENDIX A - Good Little Buoys

L. Gilman
President

SOFTLITE
IONOMER FOAM

THE GILMAN CORPORATION

Gilman, CT 06336

1-800-622-3626

203-887-7080

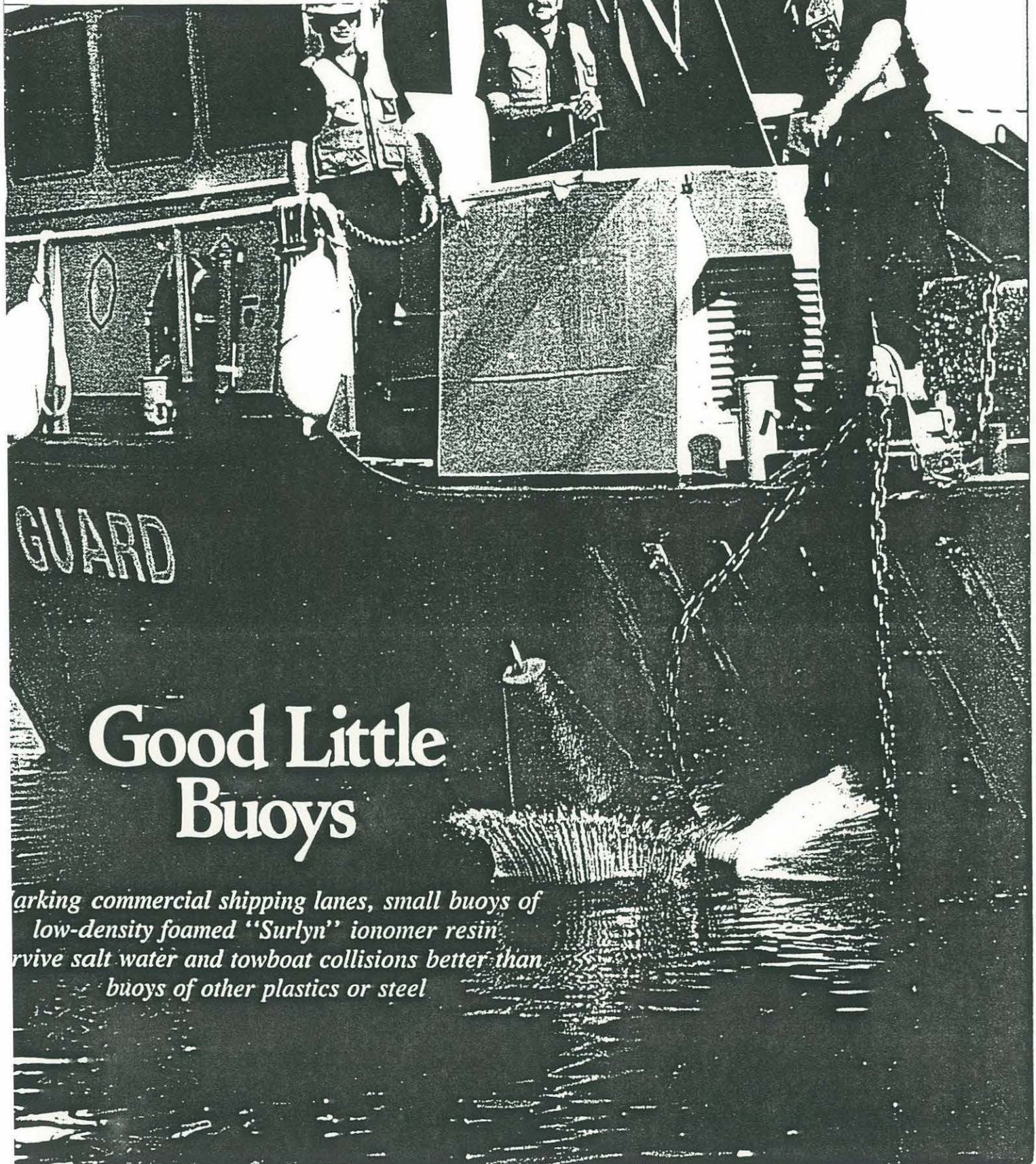

Good Little Buoys

*Marking commercial shipping lanes, small buoys of
low-density foamed "Surlyn" ionomer resin
survive salt water and towboat collisions better than
buoys of other plastics or steel*

Good Little Buoys

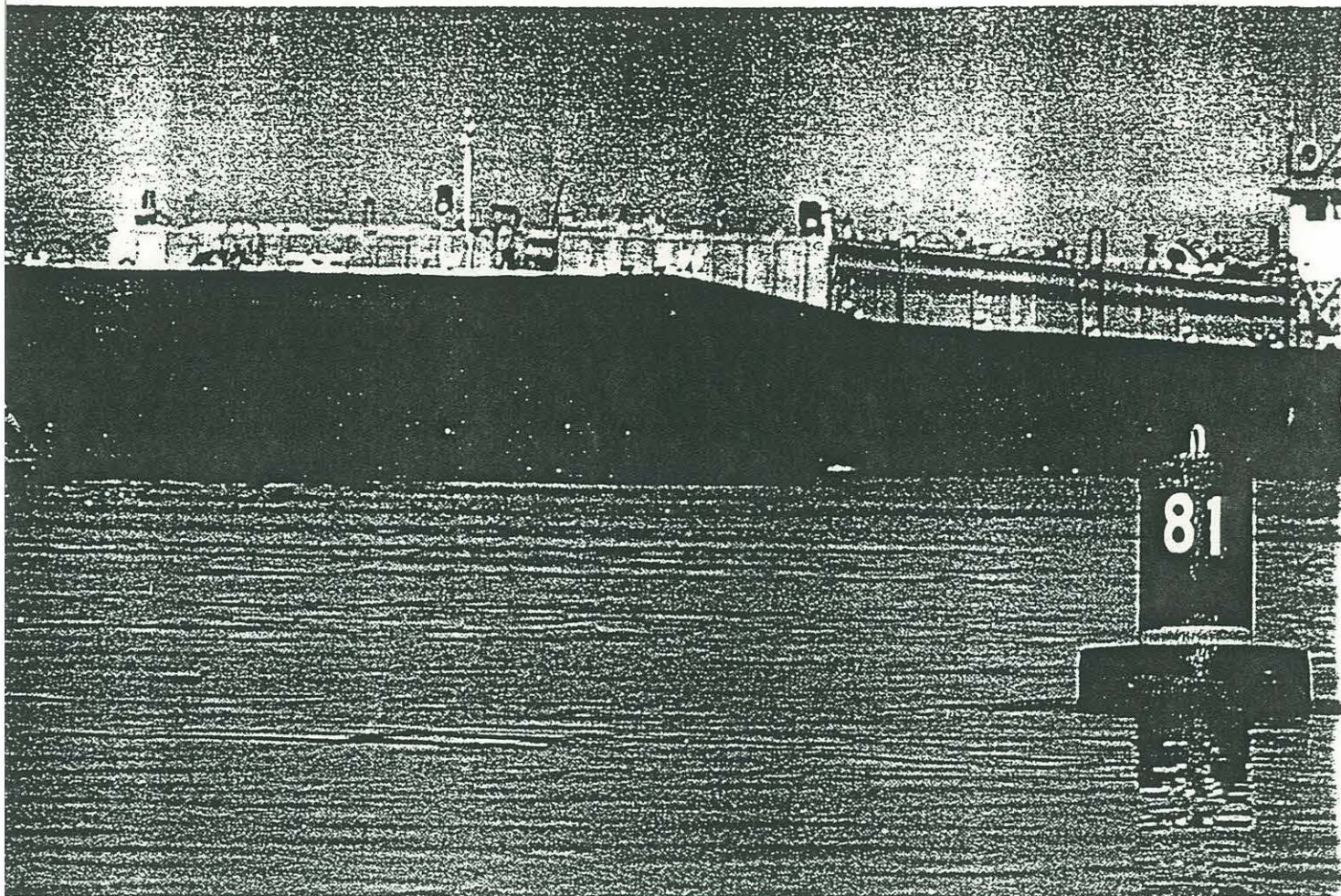

Corpus Christi, Texas

As the front line of Coast Guard efforts to aid commercial and recreational navigation, buoys lead a hazardous and, generally, brief existence. To help keep 40,000 miles of domestic waterways safe, buoys are deployed almost smack in the line of traffic. Before long, most fall victim to speed boats towing water skiers or towboats moving several 1,500-ton-capacity commercial barges.

"They're constantly being run over," says Sam Wilson, a chief warrant officer in the Aids to Navigation Office here. "Buoys account for more than half of the 78,000 short range aids to navigation we maintain, and they represent an investment of more than \$70 million. Obviously, the longer they stay in service, the better our return on investment. But every year, we lose about half of the 10,000 buoys on the western rivers. The buoy mortality rate is even greater here on the Gulf Intracoastal Waterway."

This extensive man-made channel

spans the entire Gulf crescent from Brownsville, Texas, to St. Mark's, Florida, forming a commercial network with inland waterways. A big in-shore ditch dug out of 1,113 miles of semitropical marshlands, the GIWW annually carries more than 100 million tons of agricultural produce, manufactured goods, iron, steel, petroleum and chemical products. Constant dredging maintains the channel's 125-foot width and 12-foot depth, allowing passage by shallow-draft barges which are pushed by towboats. Thousands of bobbing buoys line the GIWW to keep the towboats on course.

"There's a lot of traffic on the GIWW, and it's tough to navigate," Wilson explains. "There are many turns, narrow spots and, in places, there's submerged rock on both sides. Sometimes the spoilage areas—places on either side of the channel where dredged material is deposited—shift, narrowing the channel and increasing the chance of a towed barge



"SALT WATER EATS UP STEEL BUOYS IN NO TIME. I THINK THESE NEW BUOYS OF 'SURLYN' ARE GOING TO HAVE A MUCH HIGHER SURVIVAL RATE."

Chief Warrant Officer Sam Wilson, USCG

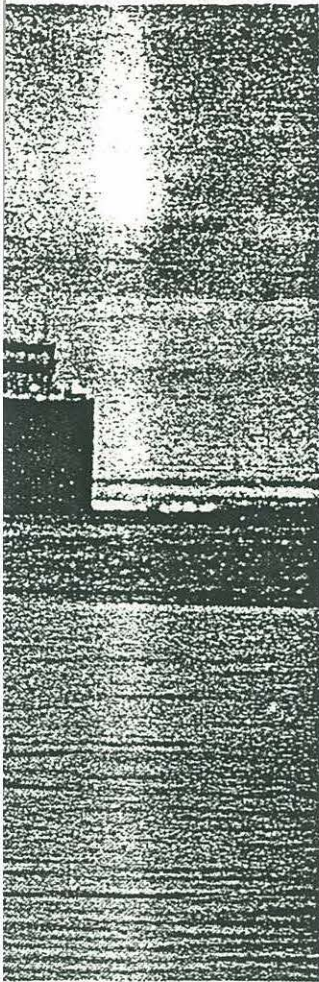

Impact resistance of "Surlyn" helps the new Coast Guard buoys survive collisions in the heavily traveled Gulf Intracoastal Waterway. Two types of foamed buoys are used: red NUN buoys (shown on page 11) and black CAN buoys (left).

running aground.

"If I were a towboat pilot pushing a \$1 million bargeload of petroleum or chemicals, and had to choose between running aground or running over a buoy, I'd hit the buoy every time."

All of the 600 buoys deployed along Wilson's 120-mile portion of the GIWW are sixth class, unlighted buoys. At five feet in height, they are the smallest ones used by the Coast Guard. In a contest with a towboat, a sixth class buoy always loses, Wilson adds.

"Most of our buoys are steel. When they get hit and their paint chips off, the salt water eats them up in no time. The collision rate is so high here that it's gotten to the point where we have to replace all our buoys every year.

"Last September, headquarters sent us 20 plastic foam buoys to try out," he continues. "A towboat nicked one of them shortly after they were deployed, but that buoy is still afloat on station. I think these new buoys are going to save us a sizable sum of money."

Floating Assignment For "Surlyn"

The new buoys are made of Du Pont "Surlyn" ionomer resin by the Gilman Corp. of Gilman, Connecticut. Gilman heats the "Surlyn", pigments it, adds a weathering package, injects "Freon" 12 blowing agent to foam the material, and then allows it to cool in sheets from 1/32nd to 1/4 inch in thickness. The company is the only U.S. supplier of the resultant low-density (three pounds per cubic foot) ionomer foam which it markets under the trademark, "Softlite".

To form the Coast Guard buoys, Gilman rolls up and simultaneously heat-seals sheets of the foam, wire-cuts the bundle to the appropriate shape, and then exposes it to heat to form a skin. "No adhesive is required because 'Surlyn' adheres to itself, other plastics, metal, glass, wood and paper with heat and pressure," notes Richard Gilman, Gilman Corp. president and developer of the foamed buoys.

"We've always used 'Freon' blowing agent to foam our 'Softlite'," he adds. "No



Buoys of foamed "Surlyn" mark shipping lanes in the Texas portion of the Gulf Intracoastal Waterway, a serpentine in-shore ditch dredged out of 1,113 miles of semitropical marshlands.

other blowing agent is as good for foaming thermoplastics to low densities."

The Coast Guard is evaluating two types of sixth class buoys of low-density foamed "Surlyn" which are being tested off Portsmouth, Virginia, and in the GIWW near Mobile, Alabama, New Orleans, and Corpus Christi.

"We expect these buoys to give us several years of maintenance-free service," says Coast Guard ocean engineer Paul Glahe. "A prototype foam buoy has been tested near Portsmouth for more than a year with no problems. At 36 pounds, they are easier to handle than a conventional 80-pound, sixth class buoy of steel. Their light weight also makes them sit higher in the water without listing. Because the foamed material doesn't absorb water or corrode, and its characteristics don't vary with temperature, we should be able to use them from New York to Guam. But impact resistance is their biggest advantage.

"This is not the first plastic buoy we've tried," Glahe adds. "But this one outperforms ABS and cross-linked polyethylene in terms of ease of fabrication, low weight and impact resistance. When a buoy of ABS is hit by a towboat, it comes up in pieces."

The high impact resistance of Du Pont "Surlyn" ionomer resin has earned it a number of assignments where hard knocks are common: bowling pin covers, softball cores, golf ball covers, auto bumpers and now waterway buoys. The Coast Guard also is evaluating the material for use in 14-foot second class buoys. For additional information on this versatile ionomer resin, write on letterhead to: "SURLYN", Du Pont Magazine, Wilmington, DE 19898. ■

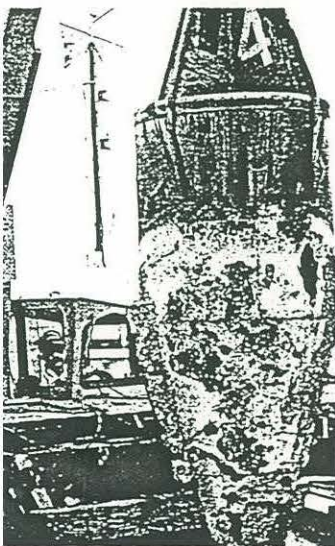

After just a few months in the briny Gulf, steel buoys must be replaced. Buoys of foamed "Surlyn" don't corrode, should provide years of reliable service.

1.7 APPENDIX B - Surlyn Product Guide

SURLYN ionomer resins are thermoplastic polymers that can take a beating. Parts made of SURLYN stay tough and beautiful even when subjected to repeated impact, low temperatures, and chemical attack. And with light weight, outstanding decorability, adhesion to other materials and versatility in processing, SURLYN ionomer resins offer endless possibilities for part design.

What is an ionomer?

An ionomer is a thermoplastic polymer that is "ionically cross-linked." Pioneered by DuPont chemists, ionomer technology entails the reaction of copolymers to form bonds between the acid groups within a chain and between neighboring chains. In the case of SURLYN, ethylene and methacrylic acid copolymers are partially reacted with metallic salts. The resultant structures are tough, transparent and resistant to chemicals.

New grades— new design options

To meet your needs for materials that result in long-lasting, good-looking, lightweight products, new grades of SURLYN are being developed. Look for grades that are tougher, stiffer or softer and more temperature resistant. For the latest information on new grades of SURLYN just call one of the sales offices listed on the back cover.

Durable—and long lasting

Resistance to impact, cuts and abrasion assures that parts made of SURLYN perform over the long haul. SURLYN is highly resistant to chemical attack and permeation by liquids. And since it contains no plasticizer which could migrate over time, its long-term performance outlook is excellent.

Tough—even at low temperatures

SURLYN offers excellent impact resistance. Room temperature tensile impact properties range from 730 to 1325 kJ/m² (345 to 630 ft/lb/in²), and at -40°C, tensile impact goes as high as 1190 kJ/m² (565 ft/lb/in²). And various grades have notched izod ratings as high as 19.

Lightweight—and foamable

Imagine a resin so lightweight that it floats on water. That's SURLYN ionomer resin. The specific gravity of SURLYN resins range from 0.94 to 0.97 g/cm³, much lighter than ABS, nylon, polyurethane, general purpose cellulosic and many other thermoplastic resins. And to reduce part weight even more, SURLYN can be foamed to densities as low as 0.56 g/cm³ with a minimal loss in physical properties.

Decorable—for excellent surface appearance

You can paint it, pigment it, hot stamp it, or use SURLYN in its natural transparent state. As a coating, SURLYN adheres well to metals, nylon, epoxy and urethane finishes. For protection under continuous outdoor exposure, UV stabilizers can be added. Whatever the look you desire, SURLYN will give you a product with excellent surface appearance.

Processing—versatility is the key

SURLYN can be injection molded, compression molded, blow molded, extruded, foamed, vacuum foamed, and thermoformed. Combining excellent flow with high melt strength and good adhesion to a variety of materials makes it ideal for insert molding. Once parts are finished, they can be joined by snap fits, welding, hot flaring lamination and stitching.

SURLYN® Ionomer Resins Property Comparisons

Property	ASTM Method	Units	SURLYN 8020	SURLYN 8528(6)	SURLYN 8550	SURLYN 8660	SURLYN 8920
Toughness							
Tensile impact at 23°C (73°F)	D-1822S	kJ/m ² ft/lb/in ²	1325 630	1160 550	1670 795	730 345	865 410
Notched izod	D-256	J/m ft/lb/in ²	No break	610 11.4	— —	855 16.0	635 11.9
Low Temp. Toughness							
Tensile impact at -40°C (40°F)	D-1822S	kJ/m ² ft/lb/in ²	870 415	935 445	540 258	565 270	725 345
Durability							
Abrasion resistance	D-1630	NBS index	150	600	214	170	640
Clarity							
Haze at 0.64 cm (0.25 in)	D-1003A	%	19	6	—	11	4
Lightweight							
Specific gravity	D-792	g/cm ³	.95	.94	.94	.94	.95
Stiffness							
Flexural modulus at 23°C (73°F)	D-790	MPa kpsi	100 14	220 32	219 31.7	230 34	380 55
Other Mechanical							
Tensile strength ⁽¹⁾	D-638	MPa kpsi	31 4.5	29 4.2	22.6 3.3	23.4 3.4	37.2 5.4
Yield strength ⁽¹⁾	D-638	MPa kpsi	— —	12.4 1.8	11 1.6	13.1 1.9	15.2 2.2
Elongation ⁽¹⁾	D-638	%	530	450	419	470	350
Ross flex, pierced ⁽²⁾ at 23°C (73°F)	D-1052	Cycles to failure	570,000	3,000	—	1,500	500
Ross flex, pierced ⁽²⁾ at -29°C (-20°F)	D-1052	Cycles to failure	1,000	<100	—	<100	<100
MIT flex ⁽³⁾	DuPont	Cycles to failure	80,000	2,100	65,000	3,300	600
Hardness, Shore D	D-2240	—	56	60	60	62	66
General							
Cation type Na or ZN	—	—	Na	Na	Na	Na	Na
Melt flow index ⁽⁴⁾	D-1238	gms/10 min.	1.0	1.3	3.9	10	0.9
Density	—	lbs/in ³	0.034	0.034	0.034	0.034	0.034
Area yield at 0.25 mm (0.10 in)	—	m ² /kg ft ² /lb	4.1 19.8	4.2 20.1	—	4.2 20.1	4.1 19.8
Thermal							
Heat deflection temperature at 455 kPa (66 psi)	D-648	°C °F	40 104	44 111	40 104	42 108	45 113
Vicat temperature	D-1525-70 Rate B	°C °F	61 142	73 163	78 172	71 160	58 136
Melting point	DTA ⁽⁵⁾	°C °F	82 180	94 201	89 192	95 203	84 198
Freezing point	DTA ⁽⁵⁾	°C °F	67 153	75 167	69 156	74 165	52 126
Coefficient of thermal expansion (-20°C to 32°C)	D-696	10 ⁻⁵ cm/cm/°C	17	14	—	15	14
Flammability	D-635	mm/min in/min	22.9 0.9	22.9 0.9	—	25.4 1.0	20.3 0.8
Flammability	(Motor vehicle safety standard 302)	Pass or fail	Pass	Pass	—	Pass	Pass
Thermal conductivity	—	10 ⁻⁴ cal/cm ² /sec/°C/cm	5.9	6.0	—	5.9	5.7
Specific heat	—	cal/gm/°C (BTU/lb/°F)					
at -20°C (68°F), \bar{x}							
at 60°C (140°F), \bar{x}							
at Melting Point, \bar{x}							
at 150°C (302°F), \bar{x}							

Note: The physical properties reported here are intended primarily for you to compare resins in the SURLYN product line. Recognize that ASTM testing methods allow alternative methods for developing a given property. Use caution in comparing data determined by alternative methods. Unless test conditions are adequately defined, it may be misleading to compare values on various supplier product data sheets

1. Type IV bars, compression molded, cross head speed 5.0 cm./min. (2 in./min.)
2. Compression molded samples 3.2 mm. (0.125 in.) thick, pierced 2.5 mm. (0.10 in.) wide.
3. Accelerated stress crack test on a strip 25 mil. thick, flexed through 270° at 170 cycles/min. with 1 kg. load in tension—#04 head.

4. Material dried 16 hours in a vacuum oven at 63°C (145°F).
5. DTA—Differential thermal analysis.
6. SURLYN 8527 has the same physical properties as 8528 but offers greater clarity.
7. SURLYN 9720 is offered for wire and cable applications. It has the same physical properties as 9721 but with

SURLYN 8940	SURLYN 9020	SURLYN 9450	SURLYN 9520	SURLYN 9650	SURLYN 9721(7)	SURLYN 9730	SURLYN 9910	SURLYN 9950	SURLYN 9970
1020 485	1285 610	925 440	1190 570	970 460	1260 600	1240 590	1020 485	1020 485	760 360
1025 19.2	No break	No break	540 10.1	775 14.5	No break	No break	365 6.8	No break	No break
760 360	1190 565	560 265	1030 490	895 425	1040 495	895 425	1010 480	660 315	640 305
370	220	170	290	270	410	360	610	130	120
5	7	31	26	27	12	15	6	18	7
.95	.96	.94	.95	.96	.96	.95	.97	.96	.95
350 51	100 14	130 19	260 38	220 32	250 36	210 0	330 48	250 37	190 28
33.1 4.8	26.2 3.8	21.4 3.1	25.5 3.7	22.1 3.2	30.3 4.4	28.3 4.1	24.8 3.6	28.3 4.1	22.1 3.2
15.9 2.3	—	8.3 1.2	12.4 1.8	12.4 1.8	11.7 1.7	11.0 1.6	13.8 2.0	12.4 1.8	11.0 1.6
470	510	500	410	410	440	460	290	490	460
1,000	90,000	3,000	1,500	1,500	1,500	3,000	1,000	3,000	3,000
<100	<100	<100	<100	<100	<100	<100	<100	100	<100
1,200	36,000	3,400	4,800	1,600	1,700	3,400	1,000	7,000	3,200
65	55	54	60	63	61	63	64	62	62
Na	Zn	Zn	Zn	Zn	Zn	Zn	Zn	Zn	Zn
2.8	1.0	5.5	1.1	5.0	1.0	1.6	0.7	5.5	14.0
0.034	0.035	0.034	0.034	0.034	0.035	0.034	0.035	0.034	0.034
4.1 19.8	4.1 19.8	4.2 20.6	4.1 19.8	4.2 20.1	4.1 19.8	4.1 19.8	4.1 19.8	4.1 19.8	4.1 19.8
44 111	40 104	41 106	42 108	48 118	43 109	40 104	44 111	47 117	40 104
63 145	57 135	79 174	74 165	71 160	71 160	73 163	62 144	66 157	61 142
83 181	81 178	95 203	96 205	92 198	92 198	91 196	84 183	88 190	83 181
68 154	64 147	84 183	76 169	73 163	76 169	75 167	65 149	74 165	68 154
10	17	16	15	15	16	16	14	15	14
22.9 0.9	25.4 1.0	20.3 0.8	17.8 0.7	22.9 0.9	25.4 1.0	20.3 0.8	22.9 0.9	22.9 0.9	27.9 1.1
Pass	Pass	Pass	Pass	Pass	Pass	Pass	Pass	Pass	Pass
5.9	5.7	6.6	5.8	5.9	6.0	6.0	5.6	5.8	5.8
		0.43							
		0.58							
		0.86							
		0.55							

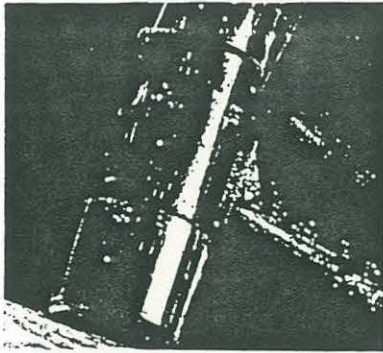

Impact strength

The excellent impact toughness of SURLYN, combined with elasticity, helps extend the life of this soft-faced hammer tip.

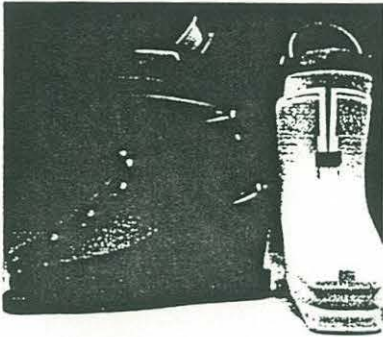

Low temperature toughness

SURLYN stays tough even at frigid temperatures. Resistance to cuts and scratches, salts and de-icing chemicals makes it a choice material for ski boots.

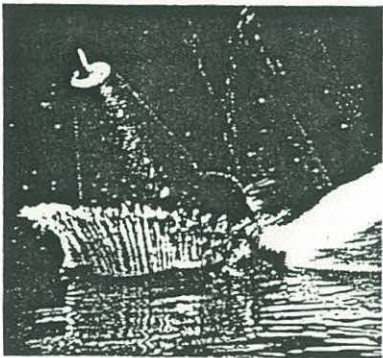

Lightweight

Buoys of foamed SURLYN weigh half as much as conventional steel buoys, yet better survive salt-water and towboat collisions.

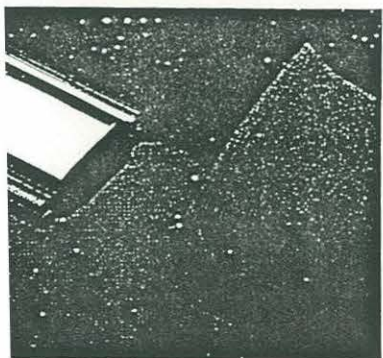

Decorable

Designers of automotive trim and decorative parts choose SURLYN for its good colorability and excellent adherence to other materials.

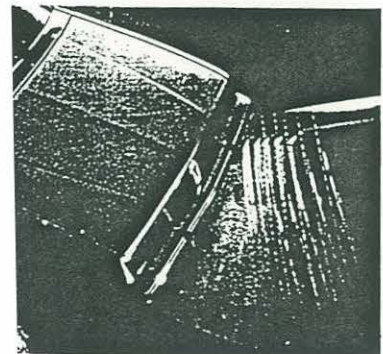

Foamable

A bumper guard of injection-molded, foamed SURLYN weighs up to 2 pounds less than steel and rubber guards and withstands impacts of 5 mph.

SURLYN® Grade Selector Chart

	8020	8528	8550	8660	8920	8940	9020	9450	9520	9650	9721	9730	9910	9950	9970	
Tough																
Toughness	○	○	○		○	○	○		○		○	○	○			
Low Temp. Toughness							●		●		●					
Durable																
Abrasion Resistant	○	●	○		●		○		○		○		●	○		
Tear Resistant	○					○		○				○		○	○	
Decorable																
Clear	○	●			●	●	○						●	○	●	
Good Adhesion								●			●		●	●	●	
Stiff																
Stiffness					●	●							●			
Processing Versatility																
Foamable			○	●			○				○					●
Injection Molding	○	○	○	○	○	○	○	○	○	○	○	○				○
Blow Molding	○		○		○		○		○		○		○			
Sheet & Shape	○	○	○		○	○	○	○	○		○	○	○			
Wire Insulation								○				○		○	○	
Metal Lamination								○				○		○	○	

● Best candidate
○ Suitable candidate

Depend on DuPont for Quality

When you specify SURLYN® ionomer resins you get resins which are backed by DuPont's quality assurance.

Quality at DuPont means the consistent production of product to standards, ensuring that the SURLYN resin you order performs consistently. SURLYN resins are backed by integrated supplies of feedstocks and intermediates which are quality controlled from the ground up. Controls are applied to raw materials, measurement systems, processes and product release. Final product testing confirms that the product you get meets specifications.

In addition to product quality, you can rely on DuPont for new products to meet your changing needs, on-time delivery, accuracy in package labeling, error-free order processing and competent technical service.

Call us today for more information.

DuPont Company
Polymer Products Department
Wilmington, Delaware 19898

ETHYLENE COPOLYMERS SALES OFFICES

United States
WILMINGTON
Concord Plaza-Springer Bldg.
Wilmington, DE 19898
(302) 772-6025

CHICAGO
100 Corporate North
Suite 200
Bannockburn, IL 60015
(312) 831-6445

LOS ANGELES
P.O. Box 8950
Universal City, CA 91608
(818) 985-8494

DETROIT
950 Stephenson Hwy.
P.O. Box 7013
Troy, MI 48007-7013
(313) 583-8000

Canada
TORONTO
DuPont Canada, Inc.
Plastics Division
P.O. Box 26
Toronto Dominion Center
Toronto, Ontario, M5K 1B6
(416) 362-5621

Europe
GENEVA
DuPont de Nemours
International S.A.
Polymer Products Department
(EPD)
CH-1211 Geneva 24
Switzerland
Route de Acacias 50-52
(022) 37 81 11

Latin America
Australia
New Zealand
Far East
**INTERNATIONAL MARKETING
SECTION**
Wilmington, DE 19898
(302) 774-6408

The technical data contained herein are guides to the use of DuPont resins. The advice contained herein is based upon tests and information believed to be reliable, but users should not rely upon it absolutely for specific applications. It is given and accepted at user's risk and confirmation of its validity and suitability in particular cases should be obtained independently. The DuPont Company makes no guarantee of results and assumes no obligation or liability in connection with its advice. This publication is not to be taken as a license to operate under, or recommendation to infringe any patents.



Chapter 2

CREEP TESTS OF SPECTRA ROPES

by Henri Berteaux and Matthew Gould

2.1 TEST OBJECTIVE

Assess the Creep characteristics of ropes made of Spectra fibers when loaded in sea water at low temperature.

2.2 TEST SET UP

A typical test set up for any sample did consist of: a test weight and hardware, a length of wire rope, the test sample, and a length of wire rope (See Figure 1).

Measurements of elongation were made under full tension by hauling the sample over a sheave for easy, precise measurements. The length of the lower wire rope was long enough to keep the loading weight *immersed* during the measurement. The length of the upper wire rope was long enough to maintain the entire sample in sea water at all tide levels.

2.3 ROPE CONSTRUCTIONS TESTED

1. **Rope #1.** This rope has a steel reinforced, cut resistant white jacket and a wire rope construction core made of Spectra fiber S-900. Diameter is 1/4 inch, strength is 7800 lbs., manufacturer is Whitehill.
2. **Rope #2.** This rope has a polyester jacket with a color marking. The rope is a 2 in 1 construction of braided Spectra S-900. Diameter is 1/4 inch, strength is 4500 lbs., manufacturer is Samson.
3. **Rope #3.** This rope is our standard 1/4 inch wire rope construction Kevlar 'Jetstrand' with a polyester jacket. Strength is 6000 lbs., manufacturer is Whitehill. Samples of these (3) types of rope were cut and spliced at both ends by personnel of the OS&M Lab, Woods Hole Oceanographic Institution.

SPECTRA CREEP TEST MEASUREMENT SCHEME

SPECTRA CREEP TEST IN PROGRESS

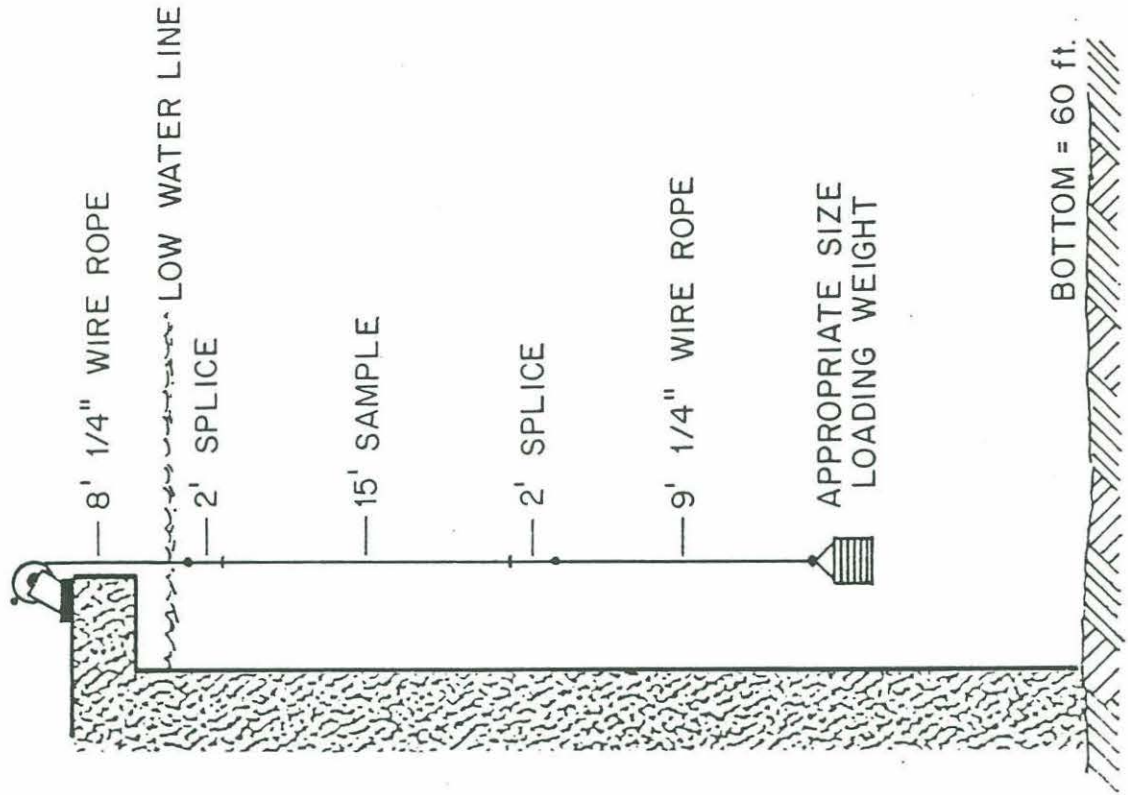
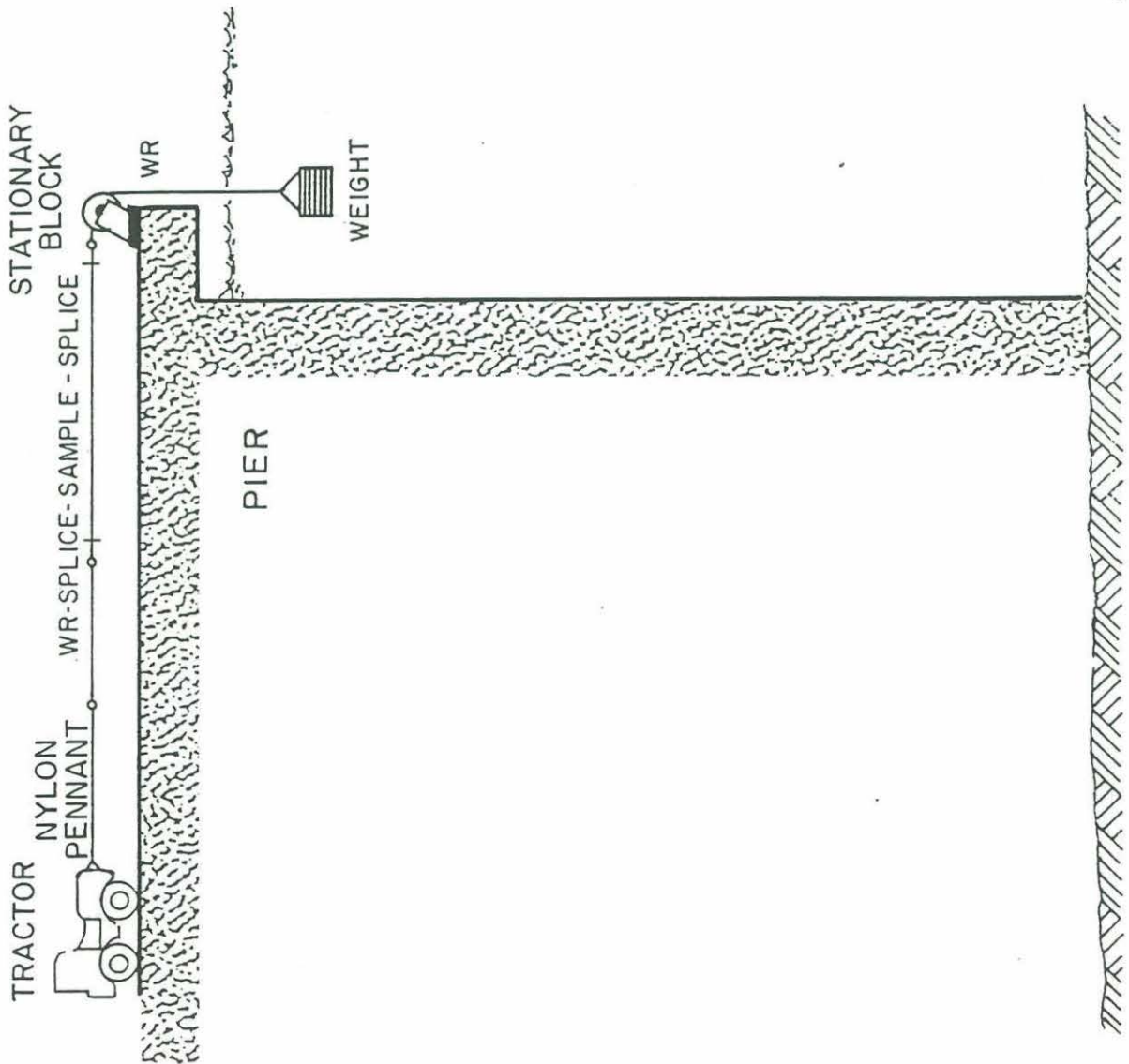

Figure 2.1 Spectra and Kevlar Ropes Test Set Up

2.4 ROPE TEST SAMPLES

2.4.1 The test samples were numbered as follows:

- Sample #1: Rope #1
- Sample #2: Rope #1
- Sample #3: Rope #2
- Sample #4: Rope #2
- Sample #5: Rope #3

All five samples had the same test length. This length was 15 feet as measured with a load of 50 lbs. applied to each sample. The length was carefully and permanently marked, with two markers at each end. The markers were at least 12 inches away from the sample terminations.

2.4.2 Test Loads

Samples #2, #4, and #5 were loaded to 40% of Rated Breaking Strength (RBS).
Samples #1 and #3 were loaded to 20% of RBS.

2.4.3 Actual Loads (as measured in sea water)

Sample #1 - 1560 lbs.	Sample #2 - 3120 lbs.
Sample #3 - 900 lbs.	sample #4 - 1800 lbs.
Sample #5 - 2400 lbs.	

2.5 TEST SCHEDULE

The test was conducted according to the following schedule:

1. *First day.* Measure the elongation of the (5) samples every two hours, over a normal 8 hour work period.
2. *1st Week.* Measure the elongation of all (5) samples once per day.
3. *2nd Week and subsequent.* Measure the elongation of all (5) samples once per week, at regular intervals of seven days.
4. *Sample #2 (Rope #1).* Was taken out of the test after measuring the sample on the second day (22 Jan 1988). This was done because the splices had slipped considerably and the jacket had failed in the area of one of the thimbles making the rope dangerous to handle.

2.6 FIRST LOADING STRESS VS. STRAIN CURVE

Samples of Spectra rope #1 and rope #2 were test loaded up to 40% of breaking strength using our Baldwin Universal Testing machine. The stress/strain curves for the two samples tested and shown in Figures 2 and 3.

A sample of Kevlar Jetstrand was also tested in a similar way. The corresponding curve is shown in Figure 4.

ROPE #1 (SPECTRA)

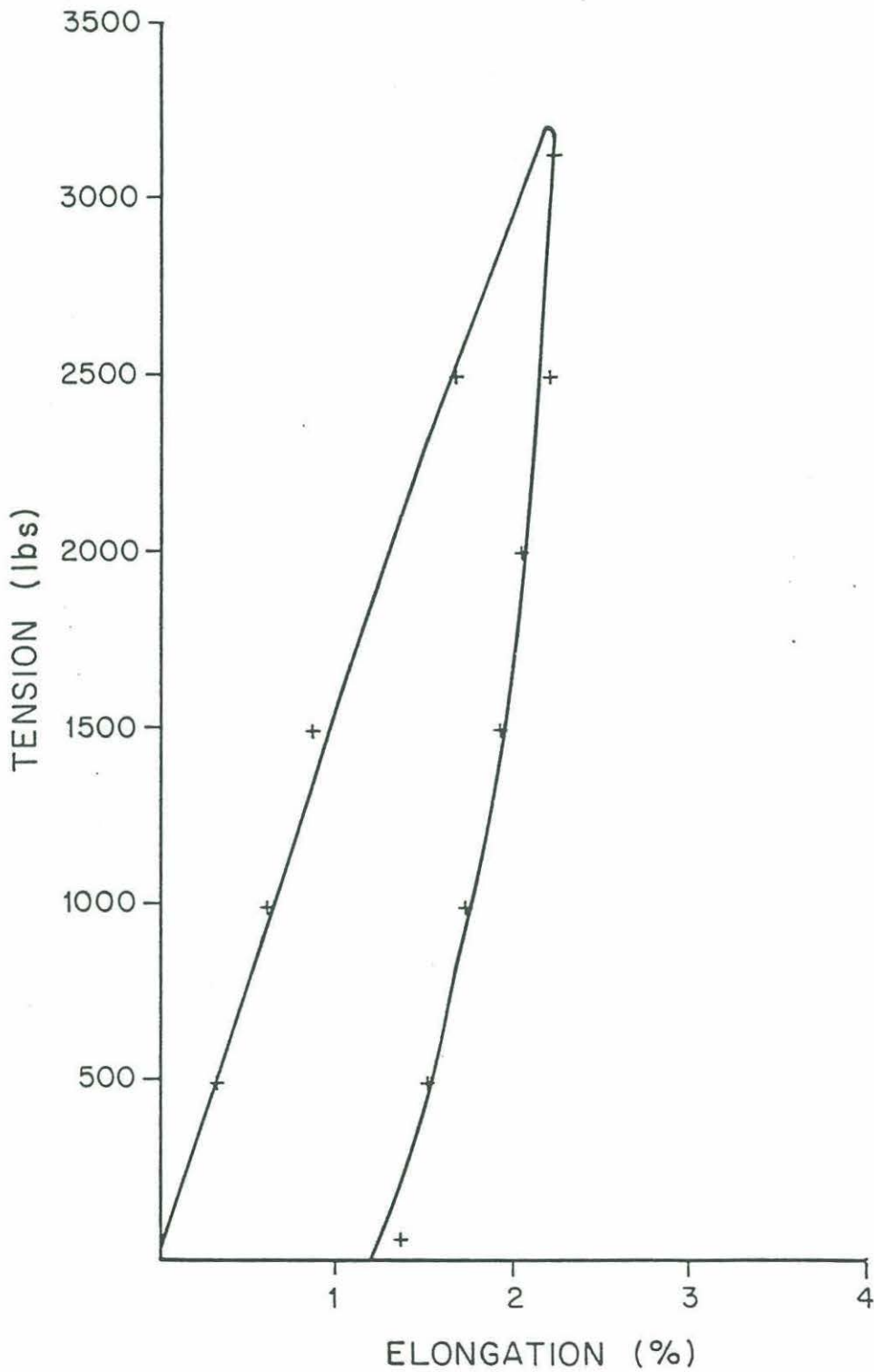

Figure 2.2 Spectra Stress/Strain Curve - Rope #1

ROPE #2 (SPECTRA)

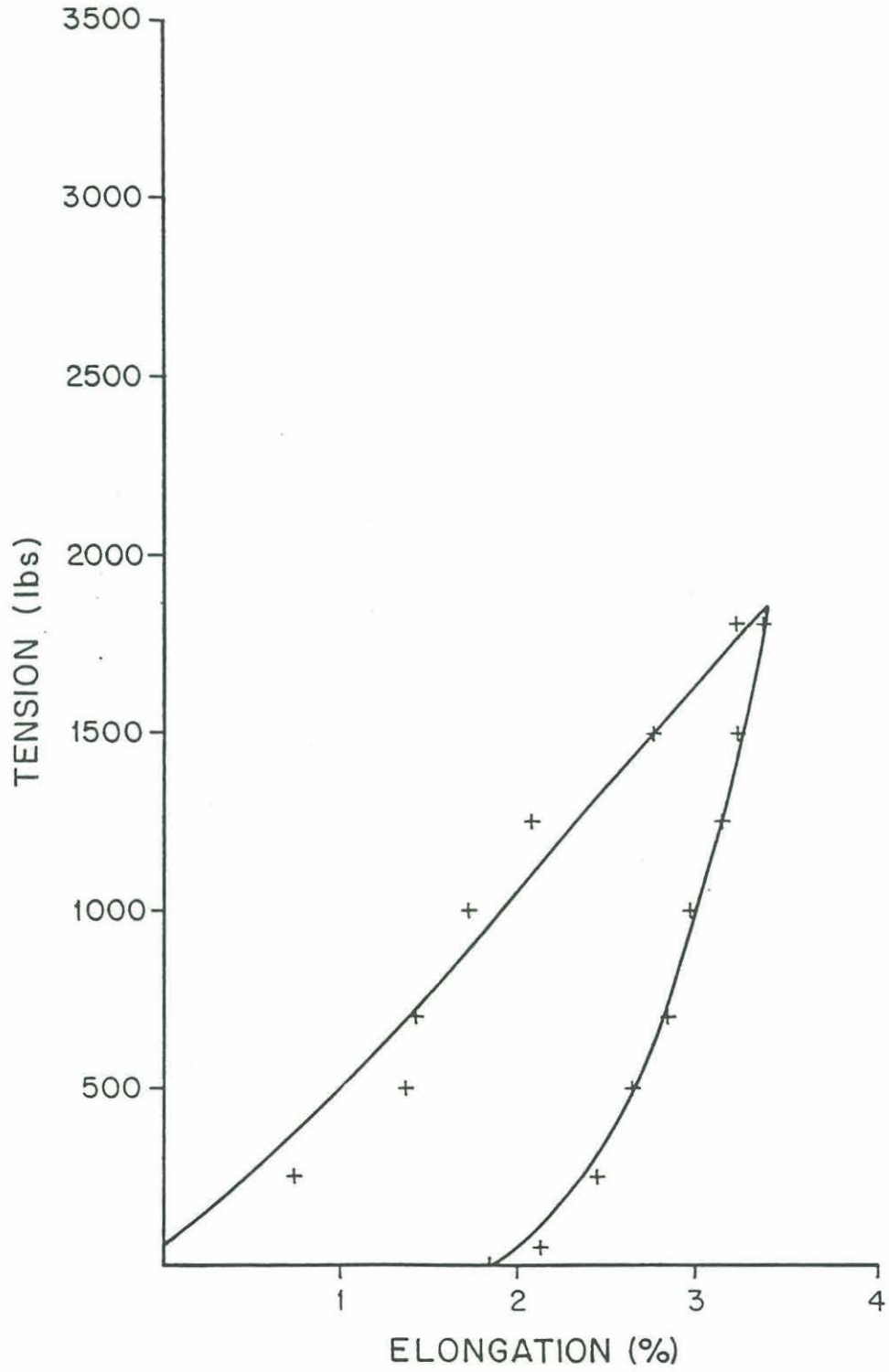

Figure 2.3 Spectra Stress/Strain Curve - Rope #2

ROPE #3 (KEVLAR)

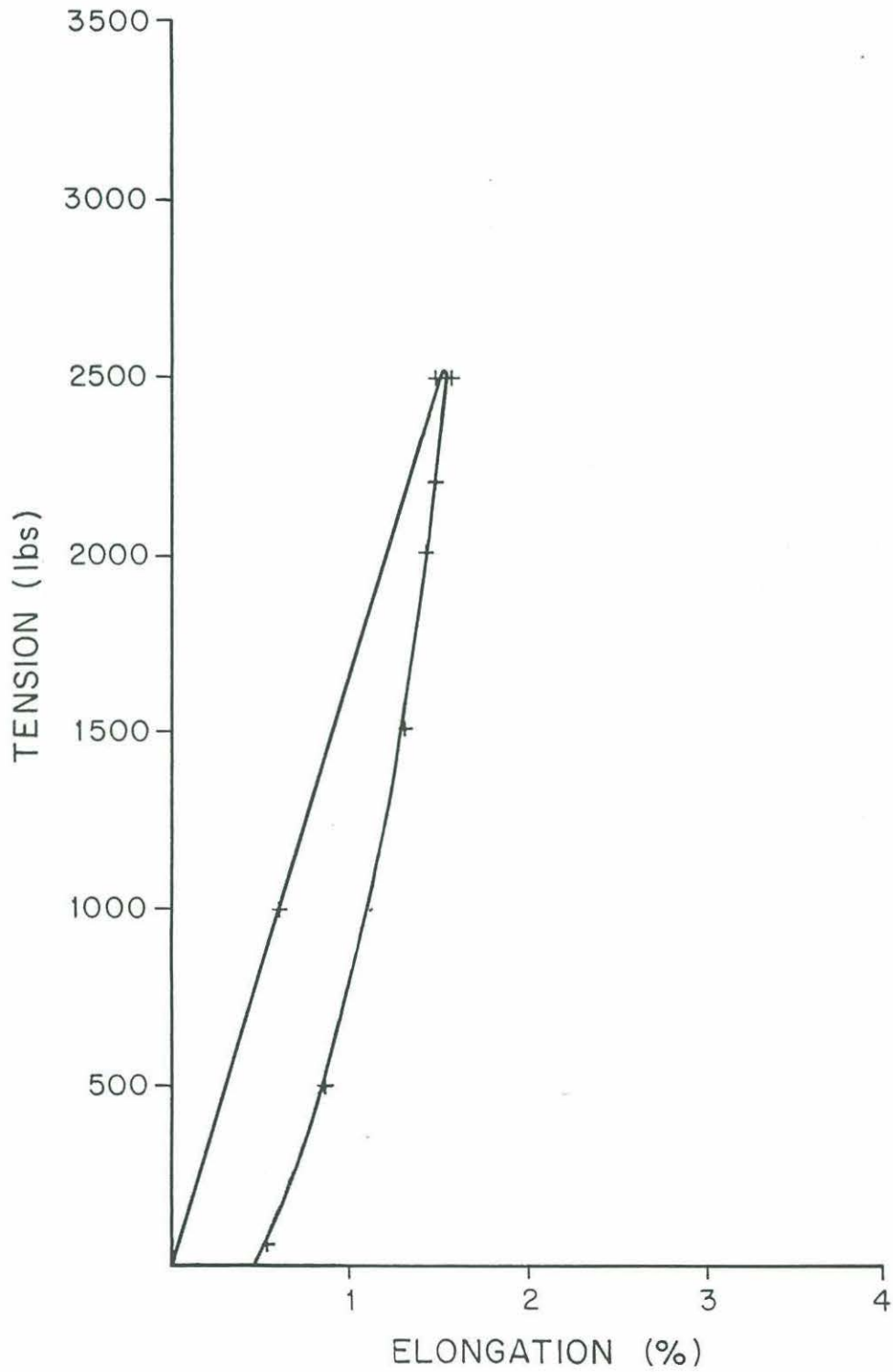

Figure 2.4 Kevlar Stress/Strain Curve - Rope #3

2.7 CREEP TEST RESULTS

2.7.1 First day loading

The series of tests started 21 January 1988. On initial loading (10:00 reading) the percent elongation were as follows:

Sample #1 - .83%	Sample #2 - 1.98%
Sample #3 - 1.77%	Sample #4 - 2.57%
Sample #5 - 1.46%	

Subsequent readings were:

(12:30 reading) Increases from previous readings are noted in ().

Sample #1 - 1.1% (+.27%)	Sample #2 - 2.12% (+.14%)
Sample #3 - 2.2% (+.45%)	Sample #4 - 3.16% (+.59%)
Sample #5 - 1.56% (+.1%)	

(14:30 reading)

Sample #1 - 1.28% (+.18%)	Sample #2 - 2.26% (+.14%)
Sample #3 - 2.29% (+.07%)	Sample #4 - 3.19% (+.03%)
Sample #5 - 1.6% (+.04%)	

(16:30 reading)

Sample #1 - 1.35% (+.07%)	Sample #2 - 2.43% (+.17%)
Sample #3 - 2.47% (+.18%)	Sample #4 - 3.26% (+.07%)
Sample #5 - 1.7% (+.24%)	

The difference between the initial loading and the 16:30 reading at the end of the first day was as follows:

Sample #1 - +.52%	Sample #2 - +.45%
Sample #3 - +.70%	Sample #4 - +.69%
Sample #5 - +.4%	

The water temperature was $33^{\circ}F$ ($.5^{\circ}C$).

2.7.2 Subsequent testing

Measurements of elongation were made according to the schedule previously discussed, and recorded in a test log book together with the water temperature. These measurements were converted in percent elongation and plotted as shown on Figures 5, 6, 7 and 8.

Water temperature at start of test was $33^{\circ}F$ ($.5^{\circ}C$) and at end of test (8 April 1988) was $43.5^{\circ}F$ ($6.4^{\circ}C$).

ROPE #1, SAMPLE #1 (SPECTRA)

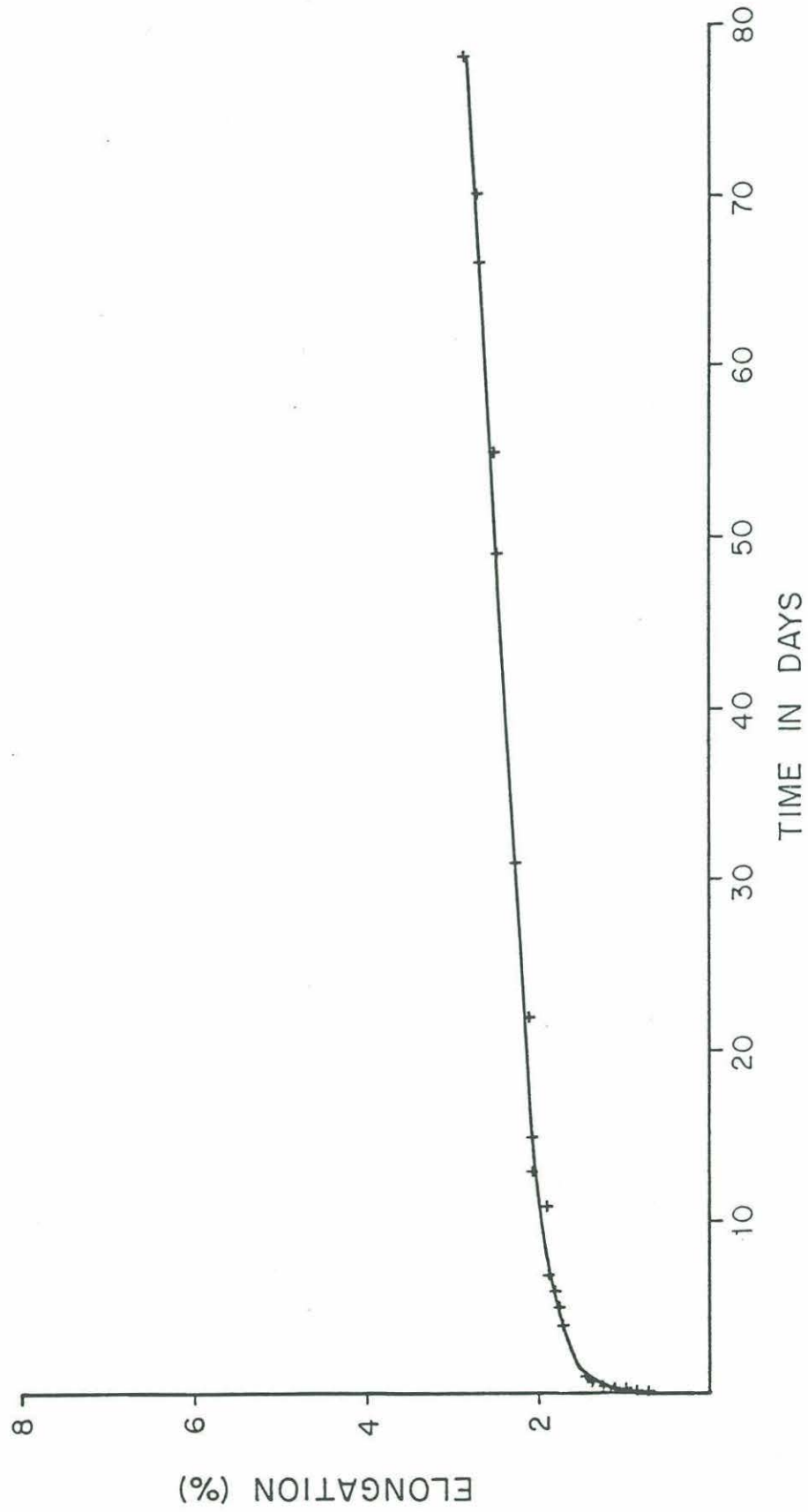

Figure 2.5 Spectra Creep Test - Rope #1, Sample #1 (Steel reinforced Whitehill jacketed Spectra)

ROPE #2, SAMPLE #3 (SPECTRA)

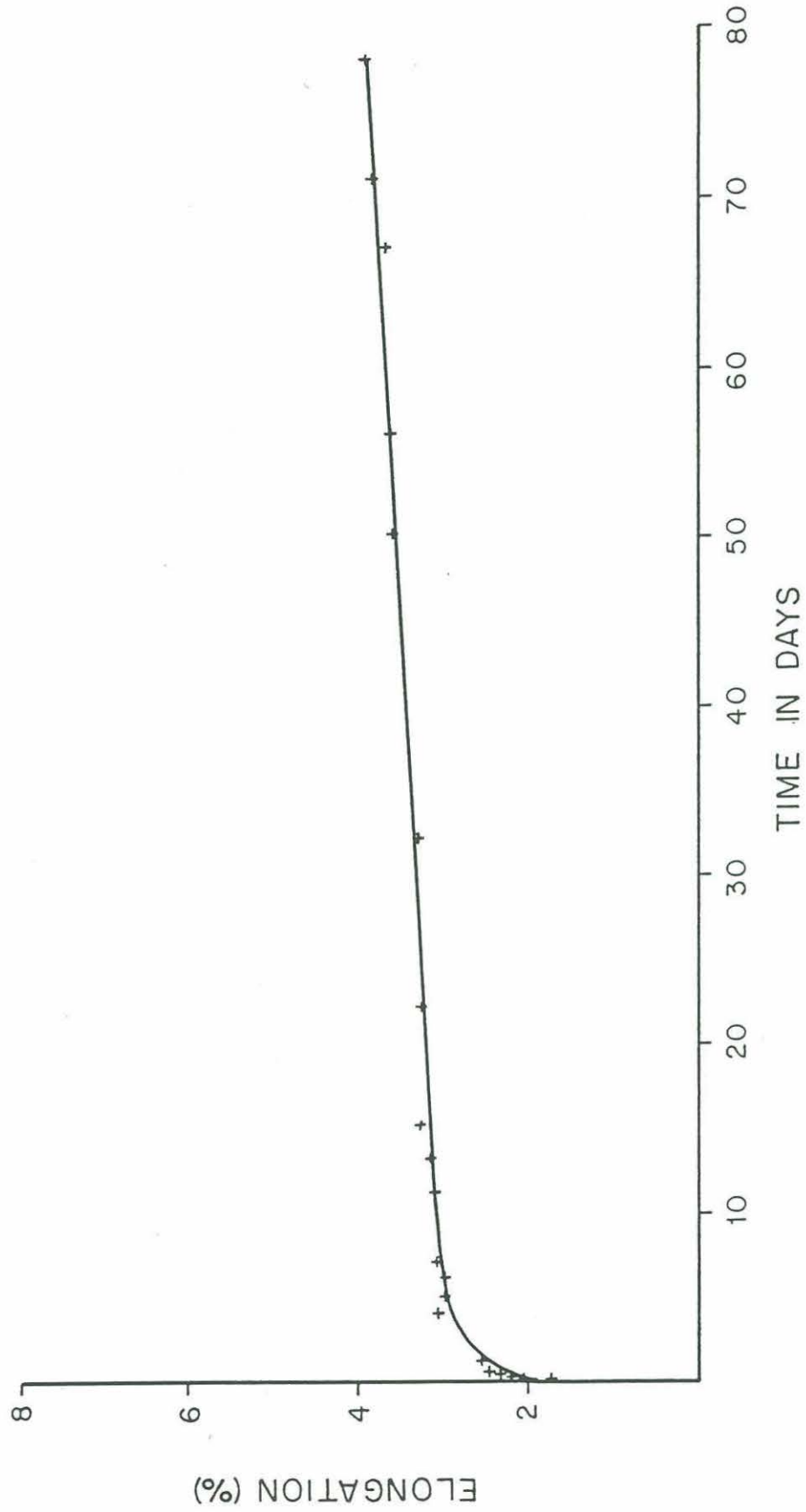

Figure 2.6 Spectra Creep Test - Rope #2, Sample #3 (Samson constructed Spectra)

ROPE #2, SAMPLE #4 (SPECTRA)

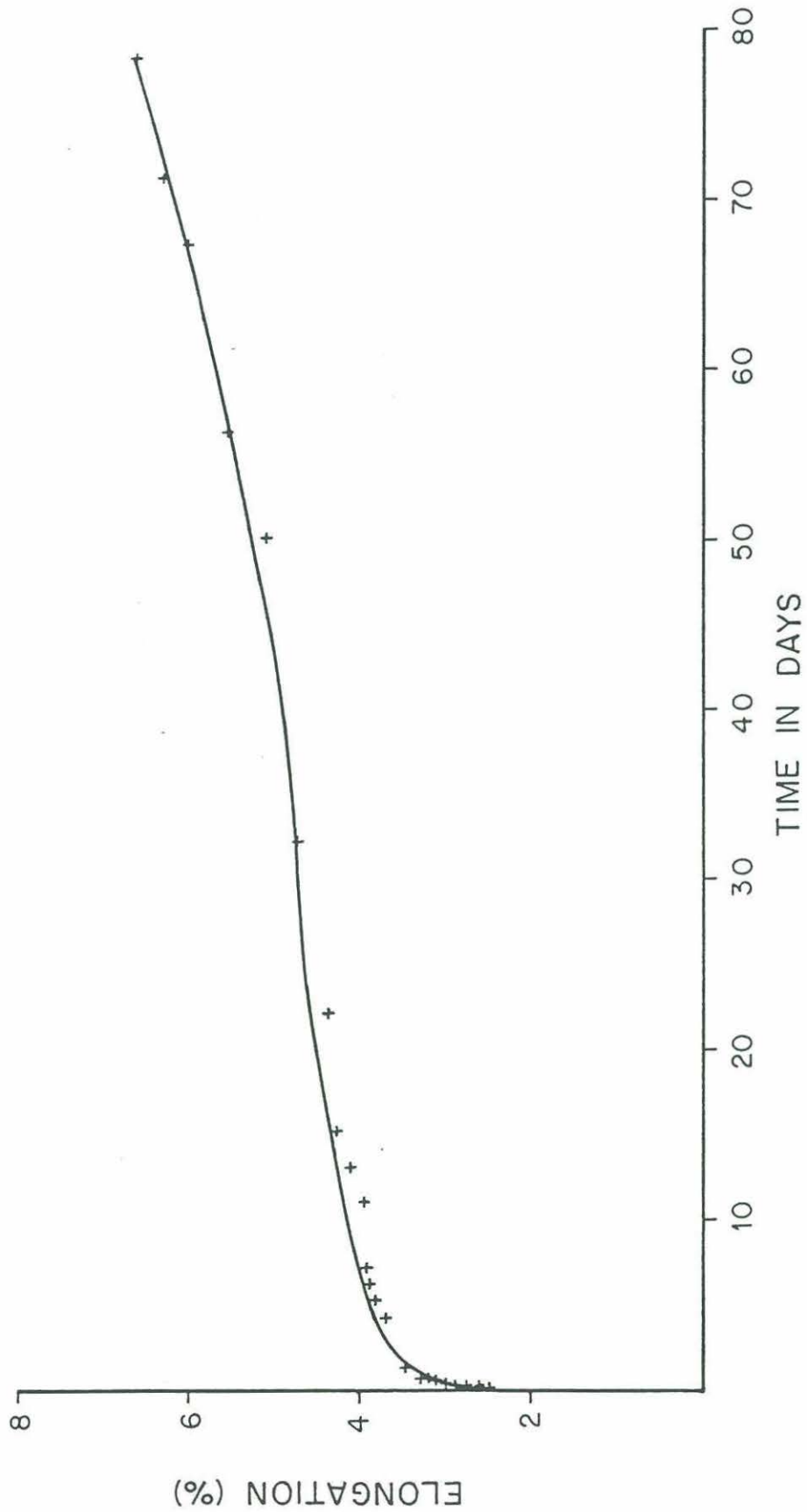

Figure 2.7 Spectra Creep Test - Rope #2, Sample #4 (Samson constructed Spectra)

ROPE #3, SAMPLE #5 (KEVLAR)

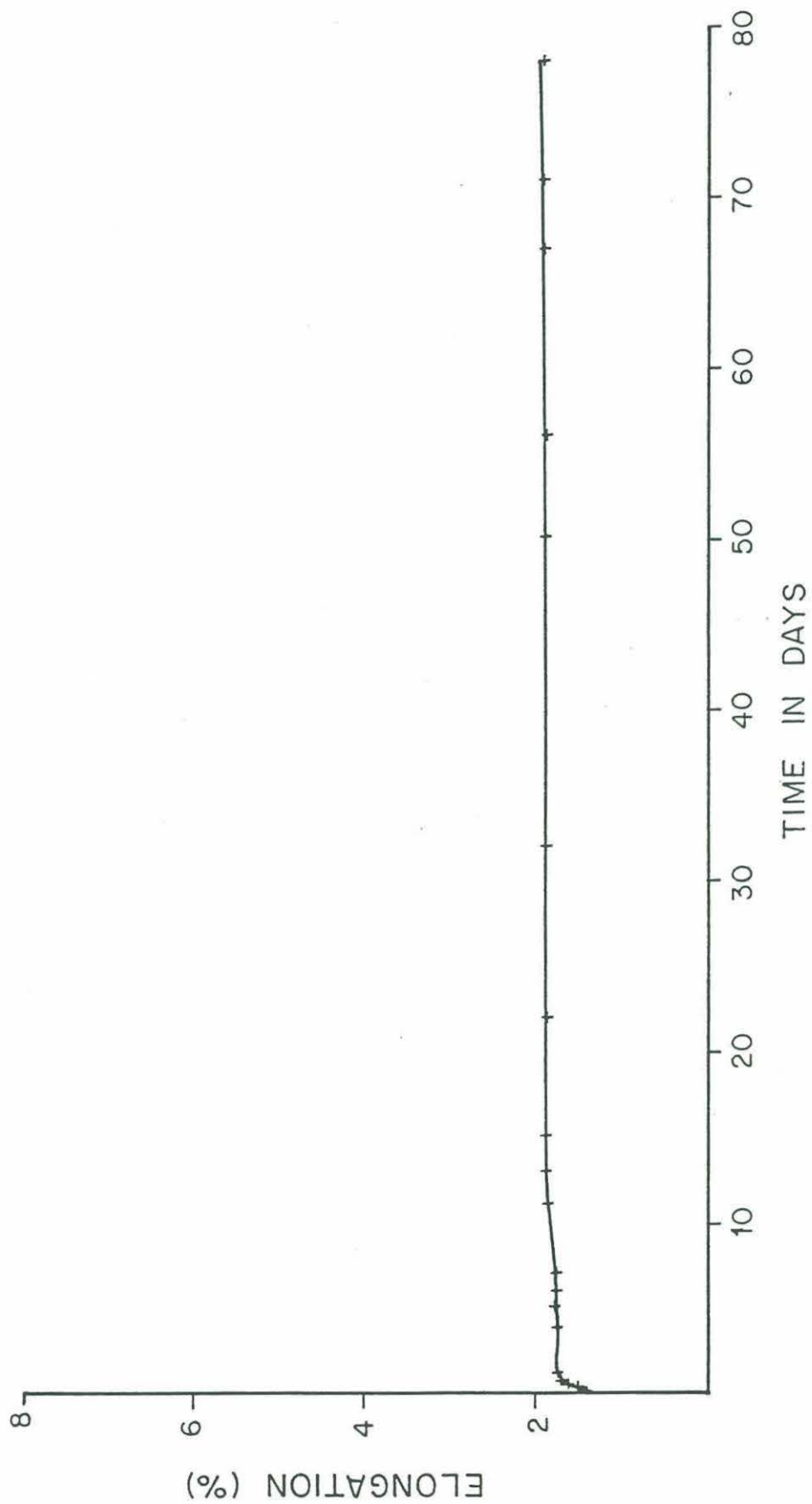

Figure 2.8 Kevlar Creep Test - Rope #3, Sample #5 (Whitehill constructed Kevlar)

2.7.3 Permanent elongation

After removal from the dock, the test samples were allowed to dry up for a few days. Their length was then again measured with a 50 lb. load applied. The percent increase over the original lengths, measured a 50 lb. load, was then calculated. The results for this "permanent" elongation are:

Rope No.	Sample No.	Permanent elongation
1	1	2.1
	2	—
2	3	2.78
	4	4.38
3	5	0.69

2.8 CONCLUSIONS

The test was designed to not only assess the actual creep of the rope specimen, but to also compare their performance under same loading conditions.

As evidenced by the creep curves, it is interesting to note that all Spectra ropes were still creeping at the end of the 80 test days, whereas the Kevlar sample seems to be stabilized. The following Table summarizes the creep test results. This result appears to contradict yarn data obtained at the same temperature but at lower loads suggesting a mechanism for very slow dimensional change that is present in rope but not in yarn.

Table 2.1: Summary of Creep Results

Rope No.	Material	Sample No.	% UBS Load	% Elongation end of test	% Elongation first loading	% Elongation due to creep
1	Spectra	1	20	2.8	1.0	1.8
		2	40	2.26*	2.0	0.26*
2	Spectra	3	20	4.0	2.0	2.0
		4	40	6.6	3.4	3.2
3	Kevlar	5	40	2.0	1.6	0.4

* Test interrupted after 2 days.

These results indicate the following:

- Rope #2 elongates more than rope #1, yet at 20% load they both creep approximately the same.
- As expected, the larger the load the larger the creep.
- If creep rates at 40% were the same for both ropes, then rope #1, sample #2 would have elongated 5.5% or so at the end of 80 days.
- The values obtained at the end of the tests are not as severe perhaps as expected. They still are too big for long term mooring applications. The disturbing observation also

must be made that creep rates do not decrease at the end of the test, thus indicating the strong possibility of more creep as a function of time.

- The Kevlar sample results confirm previously established results of about 2% elongation for 40% of UBS, with only 0.4% due to creep. Creep rate at the end of the test is also vanishing.

Given these results and the attractive properties of Spectra fibers, it seems that longer tests (say up to 12 months) made on one or two improved rope constructions should be performed. Ropes made from Spectra 1000 should be included in these additional tests. Yarn and incomplete rope data suggest creep levels should be reduced to at least one-fourth.

DOCUMENT LIBRARY

August 9, 1988

Distribution List for Technical Report Exchange

Attn: Stella Sanchez-Wade
Documents Section
Scripps Institution of Oceanography
Library, Mail Code C-075C
La Jolla, CA 92093

Hancock Library of Biology &
Oceanography
Alan Hancock Laboratory
University of Southern California
University Park
Los Angeles, CA 90089-0371

Gifts & Exchanges
Library
Bedford Institute of Oceanography
P.O. Box 1006
Dartmouth, NS, B2Y 4A2, CANADA

Office of the International
Ice Patrol
c/o Coast Guard R & D Center
Avery Point
Groton, CT 06340

Library
Physical Oceanographic Laboratory
Nova University
8000 N. Ocean Drive
Dania, FL 33304

NOAA/EDIS Miami Library Center
4301 Rickenbacker Causeway
Miami, FL 33149

Library
Skidaway Institute of Oceanography
P.O. Box 13687
Savannah, GA 31416

Institute of Geophysics
University of Hawaii
Library Room 252
2525 Correa Road
Honolulu, HI 96822

Library
Chesapeake Bay Institute
4800 Atwell Road
Shady Side, MD 20876

MIT Libraries
Serial Journal Room 14E-210
Cambridge, MA 02139

Director, Ralph M. Parsons Laboratory
Room 48-311
MIT
Cambridge, MA 02139

Marine Resources Information Center
Building E38-320
MIT
Cambridge, MA 02139

Library
Lamont-Doherty Geological
Observatory
Columbia University
Palisades, NY 10964

Library
Serials Department
Oregon State University
Corvallis, OR 97331

Pell Marine Science Library
University of Rhode Island
Narragansett Bay Campus
Narragansett, RI 02882

Working Collection
Texas A&M University
Dept. of Oceanography
College Station, TX 77843

Library
Virginia Institute of Marine Science
Gloucester Point, VA 23062

Fisheries-Oceanography Library
151 Oceanography Teaching Bldg.
University of Washington
Seattle, WA 98195

Library
R.S.M.A.S.
University of Miami
4600 Rickenbacker Causeway
Miami, FL 33149

Maury Oceanographic Library
Naval Oceanographic Office
Bay St. Louis
NSTL, MS 39522-5001

Marine Sciences Collection
Mayaguez Campus Library
University of Puerto Rico
Mayaguez, Puerto Rico 00708

REPORT DOCUMENTATION PAGE	1. REPORT NO. WHOI-88-32	2.	3. Recipient's Accession No.
Title and Subtitle Design and Evaluation of SURLYN Foam and SPECTRA Fiber Ropes for Buoy Systems Applications			5. Report Date August 1988
Author(s) Berteaux, A. Bocconcelli, M. Gould, S. Kery			6.
Performing Organization Name and Address Woods Hole Oceanographic Institution Woods Hole, Massachusetts 02543			8. Performing Organization Rept. No. WHOI-88-32
Sponsoring Organization Name and Address Office of Naval Research Environmental Sciences Directorate Hampton, Virginia			10. Project/Task/Work Unit No.
			11. Contract(C) or Grant(G) No. CN00014-84-C-0134 (G)
Supplementary Notes This report should be cited as: Woods Hole Oceanog. Inst. Tech. Rept., WHOI-88-32.			13. Type of Report & Period Covered Technical Report
			14.
Abstract (Limit: 200 words) The WHOI Report No. 88-32 presents the results of two Engineering tests performed in the Spring, 1988 by the Ocean Structures and Moorings Laboratory, Ocean Engineering Department, Woods Hole Oceanographic Institution. The first chapter describes tests performed on SURLYN foam, a new buoyancy material. The second chapter describes tests performed on SPECTRA fiber ropes, a new rope material.			
Document Analysis a. Descriptors Buoy 5. Rope Buoyancy 6. Mooring Foam 7. SPECTRA SURLYN			
b. Identifiers/Open-Ended Terms			
c. COSATI Field/Group			
Availability Statement Approved for publication; distribution unlimited.		19. Security Class (This Report) UNCLASSIFIED	21. No. of Pages 31
		20. Security Class (This Page)	22. Price