



## Recent advances in bio-P modelling – a new approach verified by full-scale observations

Erika Varga, H el ene Hauduc, James Barnard, Patrick Dunlap, Jose Jimenez,  
Adrienne Menniti, Peter Schauer, Carlos M. Lopez Vazquez, April Z. Gu,  
Mathieu Sperandio, et al.

### ► To cite this version:

Erika Varga, H el ene Hauduc, James Barnard, Patrick Dunlap, Jose Jimenez, et al.. Recent advances in bio-P modelling – a new approach verified by full-scale observations. Water Science and Technology, IWA Publishing, 2018, 78 (10), pp.2119-2130. 10.2166/wst.2018.490 . hal-02177348

HAL Id: hal-02177348

<https://hal.archives-ouvertes.fr/hal-02177348>

Submitted on 26 May 2020

**HAL** is a multi-disciplinary open access archive for the deposit and dissemination of scientific research documents, whether they are published or not. The documents may come from teaching and research institutions in France or abroad, or from public or private research centers.

L'archive ouverte pluridisciplinaire **HAL**, est destin ee au d ep ot et  a la diffusion de documents scientifiques de niveau recherche, publi es ou non,  emanant des  tablissements d'enseignement et de recherche fran ais ou  trangers, des laboratoires publics ou priv es.

Copyright

## Recent advances in Bio-P modelling – a new approach verified by full-scale observations

Erika Varga, H el ene Hauduc, James Barnard, Patrick Dunlap, Jose Jimenez, Adrienne Menniti, Peter Schauer, Carlos M. Lopez Vazquez, April Z. Gu, Mathieu Sperandio and Imre Tak acs

### ABSTRACT

As a followup to Dunlap *et al.* (2016) presented at WWTmod 2016 in Annecy, this paper summarizes recent developments in biological phosphorus removal modelling, with special attention to side-stream enhanced biological phosphorus removal (S2EBPR) systems on which previous models proved to be ineffective without case-by-case parameter adjustments. Through the research and experience of experts and practitioners, a new bio-kinetic model was developed including an additional group of biomass (glycogen accumulating organisms – GAOs) and new processes (such as aerobic and anoxic maintenance for PAO and GAO; enhanced denitrification processes; fermentation by PAOs which – along with PAO selection – is driven by oxidation-reduction potential [ORP]). This model successfully described various conditions in laboratory measurements and full plant data. The calibration data set is provided by Clean Water Services from Rock Creek Facility (Hillsboro, OR) including two parallel trains: conventional A2O and Westbank configurations allowing the model to be verified on conventional and side-stream EBPR systems as well.

**Key words** | glycogen accumulating organisms, oxidation-reduction potential, phosphorus accumulating organisms, side-stream EBPR

**Erika Varga** (corresponding author)  
**Mathieu Sperandio**  
LISBP, INSA Toulouse,  
135 av. de Rangueil 31077, Toulouse,  
France  
E-mail: [erika.varga@insa-toulouse.fr](mailto:erika.varga@insa-toulouse.fr)

**Erika Varga**  
**H el ene Hauduc**  
**Imre Tak acs**  
Dynamita,  
7 Lieut-dit Eoupe, La Redoute, 26110 Nyons,  
France

**James Barnard**  
**Patrick Dunlap**  
Black and Veatch,  
8400 Ward Parkway, Kansas City, MO 64114,  
USA

**Jose Jimenez**  
Brown and Caldwell,  
2301 Lucien Way, Suite 250, Maitland, FL,  
USA

**Adrienne Menniti**  
**Peter Schauer**  
Clean Water Services,  
16060 SW 85th Av. Tigard, Oregon 97224

**Carlos M. Lopez Vazquez**  
IHE Delft,  
Westvest 7, Delft 2611 AX,  
The Netherlands

**April Z. Gu**  
Cornell University,  
263 Hollister Hall, Ithaca, NY,  
USA  
and  
Northeastern University,  
USA

### INTRODUCTION

As there is an increasing need for phosphorus removal from wastewaters, a wide range of treatment technologies are implemented in order to satisfy the required limits. Conventional enhanced biological phosphorus removal (EBPR), with alternating anaerobic/aerobic conditions is a widely used process. However, its stability mostly relies on the availability of influent readily degradable carbon source,

especially volatile fatty acids (VFAs). Carbon supply in the anaerobic zone often needs to be supplemented from an external source such as fermentation. An alternative solution to increase process stability where influent VFAs are not available is the implementation of an anaerobic side-stream reactor for sludge hydrolysis and fermentation (S2EBPR). *Tooker et al. (2017)* reviewed various side-stream

doi: 10.2166/wst.2018.490

Comment citer ce document :

Varga, E., Hauduc, H., Barnard, J., Dunlap, P., Jimenez, J., Menniti, A., Schauer, P., Lopez Vazquez, Gu A. Z., Sperandio, M., Tak acs (2018). Recent advances in bio-P modelling – a new approach verified by full-scale observations. *Water Science and Technology*, 78 (10), 2119-2130. , DOI : 10.2166/wst.2018.490

configurations and compared performance to conventional facilities. The authors reported higher phosphorus removal efficiency in S2EBPR systems.

Clean Water Services (CWS) is investing in infrastructure to be able to operate using multiple side-stream EBPR configurations (e.g. Westbank and return activated sludge –RAS- fermentation), while retaining the use of conventional anaerobic-anoxic-oxic (A2O) system (Schauer *et al.* 2017). A process model is an ideal tool for utilities with flexible infrastructure because the model can support the decision of which configuration is optimal for the observed influent and operating conditions. An operational model is mostly beneficial when it can further be used to support the choice of key operational parameters such as determining the optimal anaerobic detention time for RAS fermentation.

Dunlap *et al.* (2016) studied a full-scale side-stream facility (Westside Regional) and reported that with existing models, a significant parameter adjustment was necessary to meet nutrient profiles especially regarding P uptake and release parameters. In order to incorporate the observed behavior, three different modeling approaches have been suggested: multiple species metabolic model; new PAO mechanisms and multiple PAO parameters. Combining new PAO mechanisms and multiple PAO parameters, Dunlap *et al.* (2016) proposed a new model. As in S2EBPR, the PAO populations may differ from those in conventional EBPR systems, and they exhibit different metabolic traits, a second group of PAOs were introduced representing these conditions. The competition between the modeled PAO groups was dependent on the specific conditions. The first, conventional group of PAOs (PAO1) includes a wide range of species that behave similar to those observed in conventional EBPR. Under low ORP conditions, PAO1 is outcompeted by the second phenotypic group of PAOs (PAO2). In the PAO2 culture, fewer glycogen accumulating organisms (GAOs) assumed to be present and PAOs with fermentation ability such as *Tetrasphaera* is assumed to be the dominant PAO species. Fermentation by PAO2 is introduced to this model under low ORP conditions. Parameters, such as growth rate, P:VFA release ratio, anoxic growth factor, aerobic and anoxic P:PHA uptake ratio were adjusted (Dunlap *et al.* 2016).

In the ASM standard models (ASM2d, ASM2d + TUD; ASM3 + bio-P; Barker-Dold model; UCTPHO+) only one population of PAO is considered (Hauduc *et al.* 2013). In these models, the kinetic and stoichiometric parameters are calibrated to include the impact of GAO presence instead of considering the competition with GAOs. The ability of PAOs to use a wider range of substrates and the

fermentation capability under specific conditions are not considered either. Moreover, anaerobic maintenance is only considered by Barker & Dold (1997); UCTPHO+ (Hu *et al.* 2007) and ASM2 + TUD (Meijer 2004).

GAO population has been introduced in some metabolic research models (Gu *et al.* 2008; Oehmen *et al.* 2010; Lanham *et al.* 2014). The competition between the two populations has been described based on the effect of temperature, pH and carbon source (Lopez-Vazquez *et al.* 2008).

According to recent research, intracellular compounds have a major effect on both the stoichiometric and kinetic parameters of PAOs, thus affecting EBPR predictability. Welles *et al.* (2017) demonstrated that a higher poly-P content correlates with higher anaerobic kinetic rates (P release) of PAO and as the poly-P content increased the glycogen content decreased showing that poly-P is the preferred storage compound for PAOs. In addition, lower poly-P contents resulted in a higher glycogen utilization and lower poly-P hydrolysis rates under anaerobic conditions slowing down the anaerobic kinetic rates of PAO, which can be interpreted as an increasing use of glycogen accumulating metabolism in PAOs. HAc uptake rate may increase with high P/C influent ratio or return phosphorus of the sludge line, aerobic P uptake may decrease because PAO storage pool is saturated (Welles *et al.* 2017).

Denitrifying capability of PAOs and GAOs has been observed in laboratory and full-scale plants (Kuba *et al.* 1997). Also the electron acceptor under anoxic conditions may differ within PAO species (Ahn *et al.* 2001a, 2001b). Rubio-Rincon *et al.* (2017) documented that the denitrifying activity of pure a PAO culture (as *Candidatus Accumulibacter* clade I) is less significant on nitrate, whereas they show higher uptake on nitrite. On the contrary, a mixed PAO-GAO culture showed higher activity under anoxic conditions using nitrate, leading to the conclusion of GAOs (as *Candidatus Compatibacter*) reducing nitrate to nitrite in A2O systems. According to that study, GAOs are not only competitors to PAOs in the anaerobic zone, but also provide electron acceptors ( $\text{NO}_2^-$ ) in the anoxic zone.

EBPR treatment plants are designed with aeration zones operated at high dissolved oxygen (DO) levels (i.e. 2 mg/L) following unaerated zones. Low DO operation has been considered unfavorable for biological aerobic uptake of phosphorus by PAOs and is avoided in biological P removal plants. However, there are instances where low DO operation (e.g. with DO around 1 mg/L or less) has been proven successful for EBPR operation (Downing *et al.* 2014; Jimenez *et al.* 2014). The low DO environment at St Petersburg, Florida has led to phosphate uptake rates

Comment cite ce document :

Varga, E., Hauduc, H., Barnard, J., Dunlap, P., Jimenez, J., Menniti, A., Schauer, P., Lopez Vazquez, G., A. Z., Sperandio, M., Takács (2018). Recent advances in bio-P modelling – a new approach verified by full-scale observations. *Water Science and Technology*, 78 (10), 2119-2130. , DOI : 10.2166/wst.2018.490

under anoxic/low DO conditions similar to aerobic conditions. Multiple studies (Camejo *et al.* 2016; Keene *et al.* 2017) examined phylogenetic abundance variations and found that in low DO environment GAO clade are detectable, but with low relative abundance (<0.2% of total biomass according to Keene *et al.* 2017) being *Accumulibacter* the dominant PAO species. Jimenez *et al.* (2017) demonstrated simultaneous biological nutrient removal (SBNR) efficiency on full scale facility with DO concentrations ranging from 0.2 to 0.7 mg O<sub>2</sub>/L. This approach with aeration control strategy can lead to substantial energy-savings while maintaining good bio-P performance.

To describe these new findings, a new model has been developed including those processes based on the proposal of Dunlap *et al.* (2016). The new calibrated model differentiates PAOs and GAOs and introduces ORP as an indicator for dominance. The biomasses therefore represent the two extremes (from diverse PAO community e.g. with fermenting capabilities to non-poly-P accumulating GAOs) and the mixture represents the competition between the two populations whereas GAO presence reduces the performance of conventional EBPR systems due to the competition for VFA. The model was calibrated based on full plant measurements from the Rock Creek and Durham advanced wastewater treatment plants (AWWTP) operated by Clean Water Services (Hillsboro, Oregon) and batch tests performed with sludge from the Rock Creek AWWTP. Attention was paid to make sure that the new model also predicts the performance of existing calibrated system in typical, well characterized situations.

## MATERIALS AND METHODS

### Model description

The new bio-P model that has been extended was based on the Barker-Dold model (Barker & Dold 1997) approach for biological phosphorus removal. The model was developed trying to keep the structure as simple as possible while still describing wide range of processes. As the model got extended, the structure of the components has been changed alongside with the corresponding parameters.

The changes affect PAO and GAO processes (growth, maintenance, decay, carbon storage, phosphorus release and uptake, fermentation). Stoichiometric matrix and kinetic rates can be found in Annex tables A1-A5, the complete model file including parameters, calculated variables, ionic species and full stoichiometric matrix is

available on <http://www.dynamita.com/wp-content/uploads/Sumo1.xlsm>

Model concepts and processes included in the new model are the following:

- *One biomass (GAO)* is added to the widely used Barker-Dold (Wentzel) model. GAOs have been separated as a facultative anaerobic biomass, storing glycogen (GLY) under anaerobic conditions.
- *Temperature dependency* is introduced to favor GAO growth at higher temperatures.
- *A constant fraction of PAOs and GAOs are able to denitrify.* Denitrifying fraction of PAOs and GAOs are determined by using a reduction factor for anoxic growth.
- *Each microbial group uses a single carbon storage component* (PHA is stored by PAOs only and Glycogen (GLY) is stored by GAOs only), and only VFA is stored.
- *Aerobic and anoxic maintenance* were added to precede PAO and GAO decay that use PHA and GLY, respectively. Active biomass loss occurs only once the storage pools are exhausted.
- *Glycogen storage is inhibited under low ORP conditions* (e.g. side-stream EBPR processes), reducing or completely eliminating GAOs and providing a more optimal PAO performance. The PAO-GAO competition under extended anaerobic conditions is partially driven and captured by oxidation-reduction potential (ORP) conditions. Under low ORP conditions (e.g. long anaerobic retention time, side-stream processes), the difference in the intracellular polymer usage sequence and onset of biomass decay between PAOs and GAOs led to a biomass dominated by PAOs (Tooker *et al.* 2016, 2017).
- *PAO are able to ferment readily biodegradable substrate ( $S_B$ ) under low ORP conditions*, in order to simulate the behavior of putative *Tetrasphaera* genus type of organisms when subjected to longer anaerobic SRT conditions.
- *Polyphosphate stored by PAOs are considered as one variable, as opposed to the previous model, where the stored polyphosphate was fractioned into a non-releasable and a releasable part* This change allows PAOs to completely deplete poly-phosphate (PP) storage pool.

### Experimental data used for calibration and validation

In this project data from aeration basins 4 and 5 of the Rock Creek AWWTP were considered. The configuration for aeration basins 4 and 5 is shown on Figure 1. High operational flexibility is available at the facility. During the calibration period, AB4 operated as A2O (Primary clarifier effluent

Comment citer ce document :

Varga, E., Hauduc, H., Barnard, J., Dunlap, P., Jimenez, J., Menniti, A., Schauer, P., Lopez Vazquez, G., A. Z., Sperandio, M., Takács (2018). Recent advances in bio-P modelling – a new approach verified by full-scale observations. *Water Science and Technology*, 78 (10), 2119-2130.

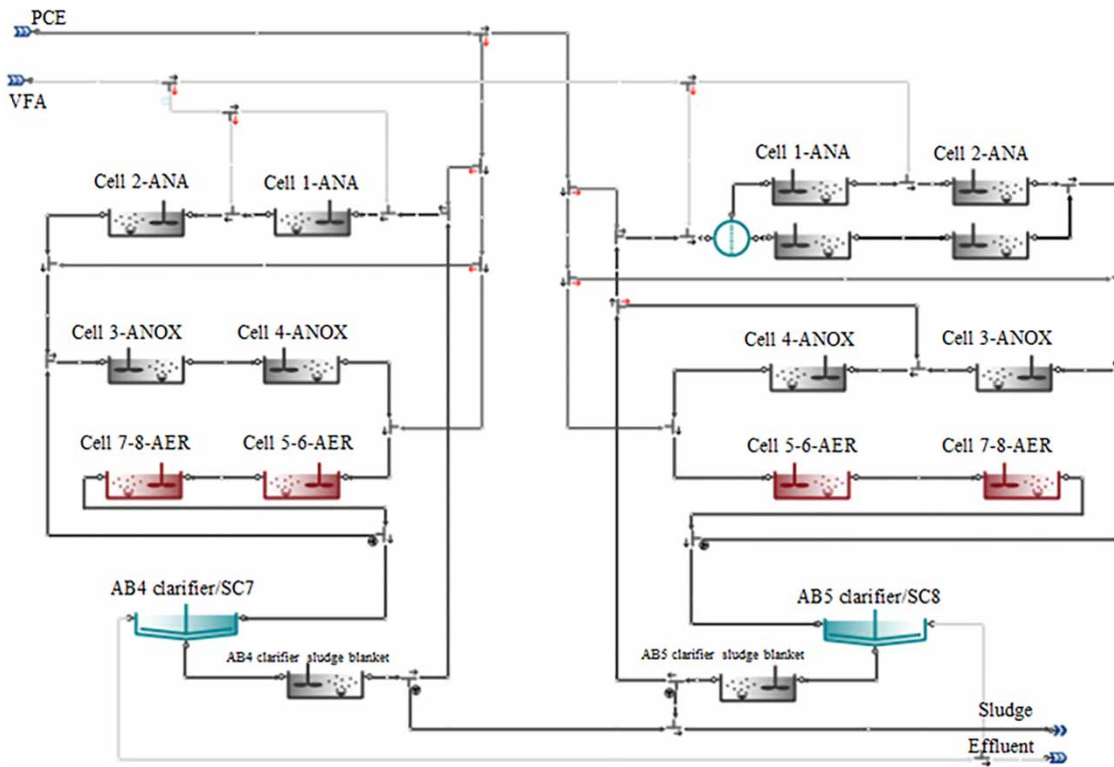

Figure 1 | Aeration basin 4 (AB4 based on A2O configuration) and aeration basin 5 (AB5 based on Westbank configuration) configuration for simulation.

(PCE) flows to anaerobic zones-Cell1), AB5 as Westbank (PCE flows to anoxic zone – cell 3 bypassing anaerobic zones).

Table 1 summarizes the detailed aeration basin volumes in un aerated and oxic zones (Anaerobic fraction may vary based on the operational settings)

**Operational settings at rock creek facility and model configuration**

For the model calibration, two parallel trains of the Rock Creek wastewater treatment plant were considered with different operational settings (Figure 1).

During the period of August 2016, the AB4 train operated as an A2O system, where all the PCE flow and return activated sludge were directed to the anaerobic Cell1 and mixed liquor recirculation to the anoxic Cell3. The flow rates were adjusted to the average of the selected period.

The AB5 train during this period is operated in the Westbank configuration with side-stream anaerobic reactors. In this type of configurations, PCE and mixed liquor recycle is directed to the anoxic reactor whereas the RAS flow and VFA addition flow to the anaerobic zones.

The anaerobic reactors are intermittently (rarely) mixed. To reflect this situation in the model, each anaerobic zone is split into two parts: a lower part with more concentrated

Table 1 | Aeration basin volumes of rock creek facility

	Basin 4	Basin 5	Unit
Total Basin Volume	6,380	6,380	m <sup>3</sup>
Total Anaerobic Volume	620	620	m <sup>3</sup>
Cell 1	307	307	m <sup>3</sup>
Cell 2	313	313	m <sup>3</sup>
Total Anoxic Volume	620	620	m <sup>3</sup>
Cell 3	310	310	m <sup>3</sup>
Cell 4	310	310	m <sup>3</sup>
Total Oxic Volume	5,140	5,140	m <sup>3</sup>
Cell 5	1,285	1,285	m <sup>3</sup>
Cell 6	1,285	1,285	m <sup>3</sup>
Cell 7	1,285	1,285	m <sup>3</sup>
Cell 8	1,285	1,285	m <sup>3</sup>
% Oxic	80.6%	80.6%	
% Un aerated	19.4%	19.4%	
% Anaerobic	9.7%	9.7%	

Comment citer ce document :

Varga, E., Hauduc, H., Barnard, J., Dunlap, P., Jimenez, J., Menniti, A., Schauer, P., Lopez Vazquez, Gu A. Z., Sperandio, M., Takács (2018). Recent advances in bio-P modelling – a new approach verified by full-scale observations. *Water Science and Technology*, 78 (10), 2119-2130.

Version postprint



sludge (concentration  $\sim 2.5\%$  in PAO-GAO model) and an upper part with lower MLSS concentration. This is the ‘compartmental approach’ applied by Le Moullec *et al.* (2010). It is assumed that the samples were taken from this upper part of the reactor. Regarding the flow and the volumes, 30% of the volume is considered in the settled zone. The internal mass flow splitting can be adjusted to the current conditions.

Schauer *et al.* (2017) demonstrated the effect of different configurations on the effluent  $\text{PO}_4$  concentration and concluded that the Westbank process with mixers turned off is beneficial for biological phosphorus removal. Even though there were uncertainties in the sampling locations, the calibration data set had been selected for this period. Figure 2 presents the effluent  $\text{PO}_4$  concentration in each train versus the influent VFA to  $\text{PO}_4$  ratio. The performance of the Westbank train does not depend on the influent VFA as much as the conventional, A2O train, which could be explained by the fermentation that may be occurring in the anaerobic zone, more specifically in the settled sludge phase.

In the clarifier underflows, reactors have been inserted to simulate the effect of the sludge blanket (anaerobic conditions) in secondary clarifiers. The sludge blanket plays a significant role especially regarding phosphorus release for side-stream processes. This simplified approach was chosen to avoid having to calibrate settling properties and slowing down the model with a reactive layered clarifier. These reactors (AB4 clarifier sludge blanket and AB5 clarifier sludge blanket) therefore are not considered as part of the anaerobic zones in the basins.

The calibration period was determined based on the plant performance. In June 2016 operational changes were implemented in the facility. During the following period significant effluent variation occurred on the AB4 train

(operating as conventional A2O system). The performance of both examined trains can be considered stable in August 2016; therefore, this period was selected for model calibration.

The calibration data set includes:

1. One month of operational data regarding PCE, flows and concentrations for AB4 and AB5
2. Phosphorus and nitrogen profiles through the basins, focusing on AB4 and AB5 in the selected period (weekly grab samples)
3. P release and uptake batch test

During calibration, the average values of the selected period have been used to meet steady-state conditions for the facility. Dynamic simulations have only been performed for the batch tests. Batch phosphorus release and uptake kinetic tests were performed at the Northeastern University.

### Batch activity tests

A side-stream reactor influent (RAS) sample from the AB5 train was taken on the 28th October 2016 and shipped on ice overnight for further analysis. The sample was brought to room temperature then aerated for 1 hour, and kept under anaerobic conditions for up to 36 hours. Mixing only occurred for sample collection. Every 6 hours a sample was collected for a P release and uptake tests.

In the simulation the following assumptions were considered:

- Samples diluted to  $\sim 4,000$  mg VSS/L concentration with secondary effluent
- Testing takes place at room temperature ( $20^\circ\text{C}$ )
- Nitrification is inhibited

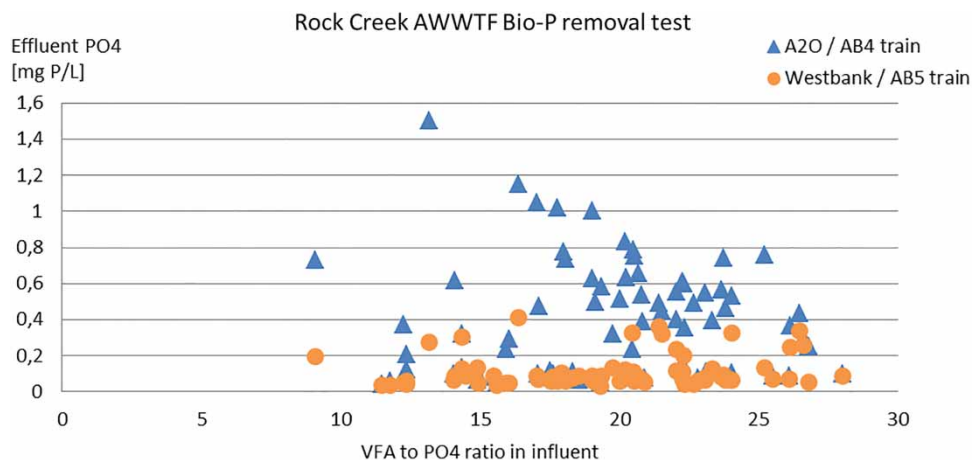

Figure 2 | Effluent  $\text{PO}_4$  versus influent VFA: $\text{PO}_4$  during testing period (Schauer *et al.* 2017).

Comment citer ce document :

Varga, E., Hauduc, H., Barnard, J., Dunlap, P., Jimenez, J., Menniti, A., Schauer, P., Lopez Vazquez, Gu A. Z., Sperandio, M., Takács (2018). Recent advances in bio-P modelling – a new approach verified by full-scale observations. *Water Science and Technology*, 78 (10), 2119-2130.

The general schedule of the test:

- After storage period, 800 ml sample was taken, 3 hours aerobic conditions (nitrification inhibitor added)
- 45 minutes of anaerobic phase, (sodium acetate addition at the start of the phase)
- 3 hours of aerobic phase

During the aerobic phase, DO concentrations reach saturation.

### Parameter estimation and calibration procedure

As a new biomass variable and new processes have been introduced to the new model, new stoichiometric and kinetic parameters have been added and some of the existing ones recalibrated.

The model calibration was carried out based on:

*Full plant configurations* managed by Clean Water Services: 1. Rock Creek Facility: datasets from the plant for AB4 and AB5, including PCE variation, full plant P profiles and operational changes; 2. Durham AWWTP: primary effluent, nutrient profile and effluent data for the selected time period as well as operational settings.

*Batch tests*: datasets from Northeastern University, including phosphorus uptake and release tests under controlled conditions

The parameter calibration procedure focuses on (only manual trial and error tuning was followed):

#### 1. *Maximum specific growth rate for PAOs and GAOs*

Formerly the base model was calibrated to the mixed culture of PAOs, including GAOs. In the new model, the maximum specific growth rate was determined to have a similar weighted average for PAO-GAO growth as the mixed culture in general configurations (although this may vary in specific configurations)

#### 2. *Fermentation rate for PAOs*

The fermentation rate was determined to ensure the VFA concentration and biomass activity for the required performance in PAO culture which did not contain GAOs (e.g. Westbank).

#### 3. *Anoxic reduction rates for PAO and GAO growth and decay*

Anoxic reduction for PAO growth was increased to match the P profile within the aeration basin and enable denitrification under specific conditions.

#### 4. *Maintenance*

Maintenance processes for both PAOs and GAOs have been introduced and considered to occur at the same rate

as decay processes, but preceding decay until the storage pool is exhausted.

#### 5. *P:VFA release ratio*

During the laboratory tests, a high P to VFA release ratio was observed. The separation of GAOs justifies raising the previously used default value for this parameter.

#### 6. *Aerobic PHA:PP uptake ratio*

Aerobic PHA to PP uptake ratio was adjusted to the batch test results with PAO cultures.

#### 7. *Oxygen half saturation*

Oxygen half saturation terms were determined to ensure PAO dominance under micro-aerobic conditions.

#### 8. *Stoichiometric yields for GAOs*

Aerobic and anoxic yields for GAO on glycogen were calibrated to encourage GAOs in the PAO-GAO competition in the aerobic and anoxic zones.

#### 9. *ORP parameters*

ORP calculations are based on dissolved O<sub>2</sub>, NO<sub>x</sub> and CH<sub>4</sub>. CH<sub>4</sub> was chosen as an indicator for low ORP conditions as this model does not consider sulfur reactions to further characterize ORP in anaerobic zones. The default value for ORP inhibition for storage in GAOs and the saturation term for PAO fermentation was determined during the calibration, and the parameters may require the adjustments for the specific configuration.

#### 10. *Temperature dependency*

GAO growth and maintenance has a higher temperature dependency as PAOs. The selected default parameter values are based on Lopez-Vazquez *et al.* (2009).

## RESULTS AND DISCUSSION

### Data set and sampling

The PCE fractions and hydraulic settings were calibrated based on a daily average dataset provided by Clean Water Services (Table 2). Table 3 summarizes the calibrated PCE concentrations. The selected period was August 2016 where both studied trains showed a stable performance. Nutrient profiles are compared to grab sample data. As these samples were taken weekly, inconsistencies to the average dataset in the aerobic zone effluent may occur based on the sampling time. As mentioned before, there are uncertainties about the representativeness of sampling locations in the unmixed anaerobic zone of AB5 train. Additionally, some back-mixing from the anoxic zone can cause an apparent P uptake (see Figure 4).

Comment citer ce document :

Varga, E., Hauduc, H., Barnard, J., Dunlap, P., Jimenez, J., Menniti, A., Schauer, P., Lopez Vazquez, G., A. Z., Sperandio, M., Takács (2018). Recent advances in bio-P modelling – a new approach verified by full-scale observations. *Water Science and Technology*, 78 (10), 2119-2130. DOI : 10.2166/wst.2018.490

**Table 2** | Calibration data set

	Variable	Unit	Numbers of measurements	Average	Minimum	Maximum
M	COD	mg COD/L	19	297	260	368
	TSS	mg TSS/L	14	77	60	102
	VSS	mg VSS/L	4	58.5	52	68
	Alkalinity	mg CaCO <sub>3</sub> /L	19	224	203	240
	TKN	mg N/L	4	42.4	37.1	46.2
	NHx	mg N/L	31	32.1	25.0	37.6
	NOx	mg N/L	9	0.53	0.10	1.59
	TP	mg P/L	4	3.83	3.50	4.16
	PO <sub>4</sub>	mg P/L	31	2.30	1.52	3.59
Secondary Clarifier Effluent (SCE) of AB4	COD	mg COD/L	9	27.4	21.1	32.5
	TSS	mg TSS/L	19	3.97	1.60	5.40
	pH		9	6.74	6.55	6.89
	Alkalinity	mg CaCO <sub>3</sub> /L	19	103.5	75.2	128.0
	NHx	mg N/L	19	0.081	0.038	0.159
	NOx	mg N/L	19	18.2	13.0	21.6
	TP	mg P/L	5	0.50	0.26	1.21
	PO <sub>4</sub>	mg P/L	31	0.23	0.04	1.50
Secondary Clarifier Effluent (SCE) of AB5	COD	mg COD/L	9	27.7	23.6	32.0
	TSS	mg TSS/L	19	3.3	2.4	5.2
	pH		9	6.70	6.54	6.85
	Alkalinity	mg CaCO <sub>3</sub> /L	19	107	79	131
	NHx	mg N/L	19	0.17	0.09	0.38
	NOx	mg N/L	19	17.5	12.0	19.8
	TP	mg P/L	5	0.28	0.19	0.49
	PO <sub>4</sub>	mg P/L	31	0.104	0.031	0.414

### AB4 results

Table 4 summarizes the average measured data set for AB4 secondary effluent in the calibration period and the simulation results of the PAO-GAO and Barker-Dold models. Due to different heterotrophic kinetics in the Barker and Dold model, a lower MLSS is observed.

Figure 3 presents nutrient profiles within the A2O system in aeration basin 4. As mentioned before, the

measured data is based on weekly grab samples, thus the differences in NOx concentration in the end of the aeration basin. Regarding the simulations, in general the PAO-GAO model shows a satisfactory agreement with the measured data. However the P release is overestimated in anaerobic zones, and nitrate concentration is generally lower. The Barker and Dold model simulates the NOx profile in A2O process properly. However, it shows a slight P release in the anoxic zone (due to decay and PP lysis) where P

**Table 3** | Rock creek primary clarifier effluent concentrations

Variable	Unit	Measured average	PAO-GAO model	difference	Barker-Dold model	difference
COD	mg COD/L	297.05	297.05	0%	294.15	-1%
TSS	mg TSS/L	76.86	118.80	+54.57%	129.50	+68.5%
VSS	mg VSS/L	58.5	100.86	+72.4%	109.60	+87.3%
Alkalinity	mg CaCO <sub>3</sub> /L	224.16	250.00	+11.53%		-
TKN	mg N/L	42.4	42.4	0.0%	42.5	+ 0.24%
NHx	mg N/L	32.14	32.14	0.0%	32.14	0.0%
NOx	mg N/L	0.53	0.53	0 mg N/L	0.53	0 mg N/L
TP	mg P/L	3.83	3.83	0%	3.5	-8.59%
PO <sub>4</sub>	mg P/L	2.3	2.3	0%	2.3	0%

Comment citer ce document :

Varga, E., Hauduc, H., Barnard, J., Dunlap, P., Jimenez, J., Menniti, A., Schauer, P., Lopez Vazquez, Gu, A. Z., Sperandio, M., Takács (2018). Recent advances in bio-P modelling – a new approach verified by full-scale observations. *Water Science and Technology*, 78 (10), 2119-2130. , DOI : 10.2166/wst.2018.490



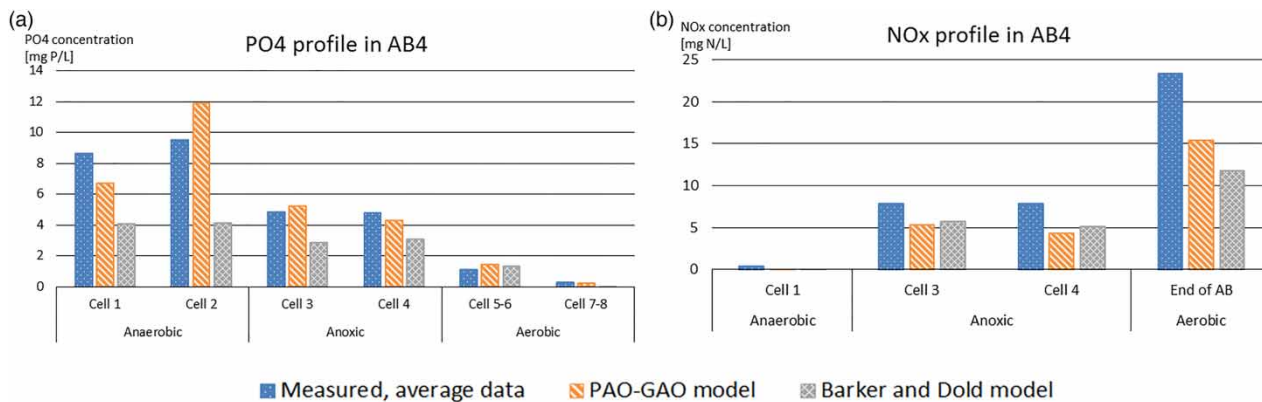

Figure 3 | Nutrient profiles in AB4 (a) PO4 profile; (b) NOx profile.

uptake is expected. According to literature experiments, the PAOs decay rate is higher under aerobic conditions, and is low/negligible under anoxic and anaerobic conditions (Siegrist *et al.* 1999; Lu *et al.* 2007) and maintenance seems to be the main endogenous process. In the PAO-GAO model, aerobic and anoxic maintenance precede decay where no P release occurs.

According to the simulation, 81% of the combined PAO-GAO population (which was formerly considered as PAO) is PAO resulting in good EBPR performance.

As observed during the simulations, in A2O configurations, the expected CH<sub>4</sub> production in the anaerobic zone (used as an indicator of deep anaerobic conditions) is relatively low which has a major impact on the ORP. Under these conditions (ORP ~ -50 mV), a PAO-GAO competition is observed. The dominant PAO population is considered to use VFA as a substrate.

### AB5 results

Table 5 summarizes the average measured data for secondary effluent in Aeration Basin 5 operating as Westbank with the simulation results.

Figure 4 shows the measured data with simulation results regarding the nutrient profile through the reactor. As discussed before, the anaerobic zones of the train were unmixed at this period, therefore part of the differences between the simulation results and measurement data can be due to that (however as presented in the AB4 simulation results, a slight overestimation of the P release was observed). Moreover, as seen on Figure 4(a) the measurements show P uptake in the anaerobic zone that is probably due to some back-mixing from the anoxic zone around the sampling point. The measured phosphorus profile in the AB5 train (Westbank) was deemed not to be

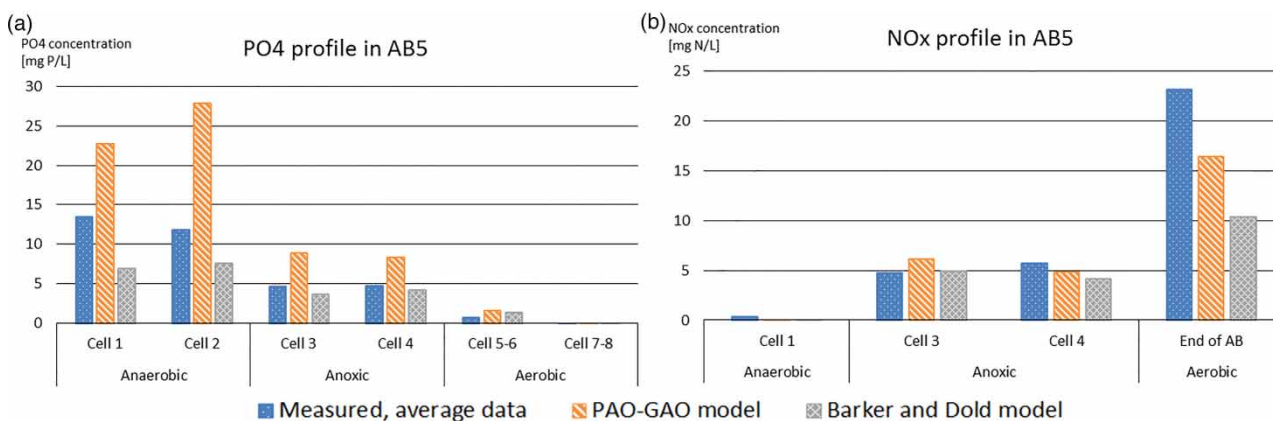

Figure 4 | Nutrient profiles in (a) PO4 profile; (b) NOx profile.

Comment citer ce document :

Varga, E., Hauduc, H., Barnard, J., Dunlap, P., Jimenez, J., Menniti, A., Schauer, P., Lopez Vazquez, Gu A. Z., Sperandio, M., Takács (2018). Recent advances in bio-P modelling – a new approach verified by full-scale observations. *Water Science and Technology*, 78 (10), 2119-2130. , DOI : 10.2166/wst.2018.490

**Table 4** | AB4 secondary effluent performance

Variable	Unit	Measured average	PAO-GAO model	difference	Barker-Dold model	difference
COD	mg COD/L	27.4	26.5	−3.28%	28.8	+5%
TSS	mg TSS/L	3.97	4.00	+0.76%	4.00	+0.76%
pH		6.74	6.46	−4.15%	–	–
Alkalinity	mg CaCO <sub>3</sub> /L	103.5	103.3	+0.19%	–	–
NH <sub>x</sub>	mg N/L	0.08	0.16	+0.079 mg N/L	0.20	+0.12 mg N/L
NO <sub>x</sub>	mg N/L	18.23	16.67	−8.56%	12.00	−34.1%
TP	mg P/L	0.50	0.48	−0.02 mg P/L	0.32	−0.17 mg P/L
PO <sub>4</sub>	mg P/L	0.23	0.24	+0.01 mg P/L	0.15	−0.08 mg P/L

**Table 5** | AB5 secondary effluent performance

Variable	Unit	Average	PAO-GAO model	difference	Barker-Dold model	difference
COD	mg COD/L	27.7	25.8	−6.9%	28.2	+1.8%
TSS	mg TSS/L	3.3	3.3	0%	3.3	0%
pH		6.7	6.45	−3.73%	–	–
Alkalinity	mg CaCO <sub>3</sub> /L	107	100.2	−6.4%	–	–
NH <sub>x</sub>	mg N/L	0.17	0.18	0 mg N/L	0.21	+0.04 mg N/L
NO <sub>x</sub>	mg N/L	17.50	16.35	−6.57%	10.31	−41.1%
TP	mg P/L	0.28	0.33	+0.05 mg P/L	0.32	+0.04 mg P/L
PO <sub>4</sub>	mg P/L	0.104	0.12	+0.016 mg P/L	0.15	+0.046 mg P/L

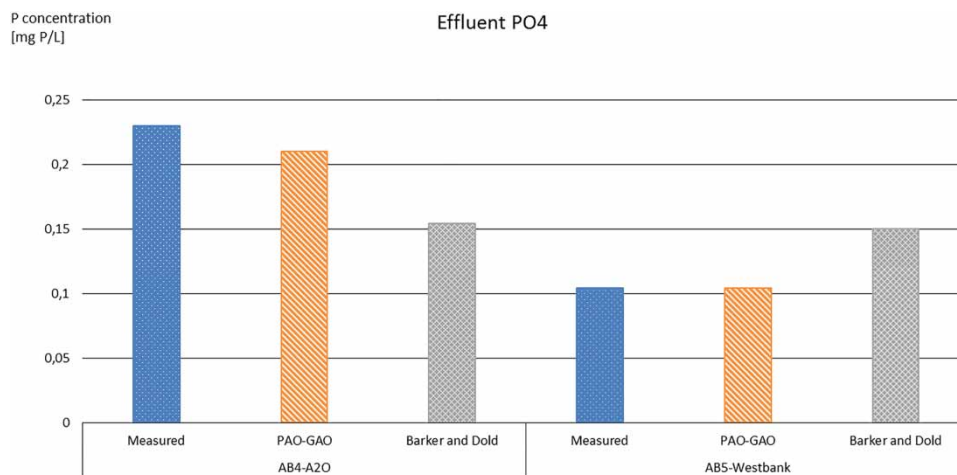
**Figure 5** | Secondary effluent P concentrations.

representative due to the sampling uncertainties therefore was not taken into account during calibration.

The observed deep ORP conditions (ORP <− 100 mV) typically are a disadvantage for the substrate uptake of GAOs. The PAO species present are able to ferment under

these conditions and also show nitrate uptake in the anoxic zone. The changing functionality according to the specific conditions cannot be properly described with previous models. Figure 5 summarizes the effluent PO<sub>4</sub> measurements and simulation results on the two trains.

Comment citer ce document :

Varga, E., Hauduc, H., Barnard, J., Dunlap, P., Jimenez, J., Menniti, A., Schauer, P., Lopez Vazquez, G., A. Z., Sperandio, M., Takács (2018). Recent advances in bio-P modelling – a new approach verified by full-scale observations. *Water Science and Technology*, 78 (10), 2119-2130. DOI : 10.2166/wst.2018.490

According to the simulations, the PAO-GAO model shows a closer correlation regarding the difference of the effluent values, which is due to the different processes in the basins.

**Batch tests**

Phosphorus release and uptake tests have been performed with sludge from the AB5 train as described in the materials and methods section in order to determine the kinetics in side-stream systems Figure 6(a)–6(f) displays the results of the laboratory measurements and the dynamic simulation.

In the simulations, the biomass was taken from AB5 RAS during the calibration period (steady state simulation). In the S2EBPR systems, low abundance of GAOs was observed in several cases (Tooker et al. 2017) and also the model predicts negligible GAO concentration due to the discussed side-stream conditions. The tests, therefore, represent a biomass where PAO-GAO competition does not have an impact on the simulations results.

Phosphorus release and uptake tests were performed in a controlled laboratory environment, the pH level target is 7.00–7.15 controlled by HCl or NaOH addition. Moreover, nitrification inhibitor was added to the sample to facilitate

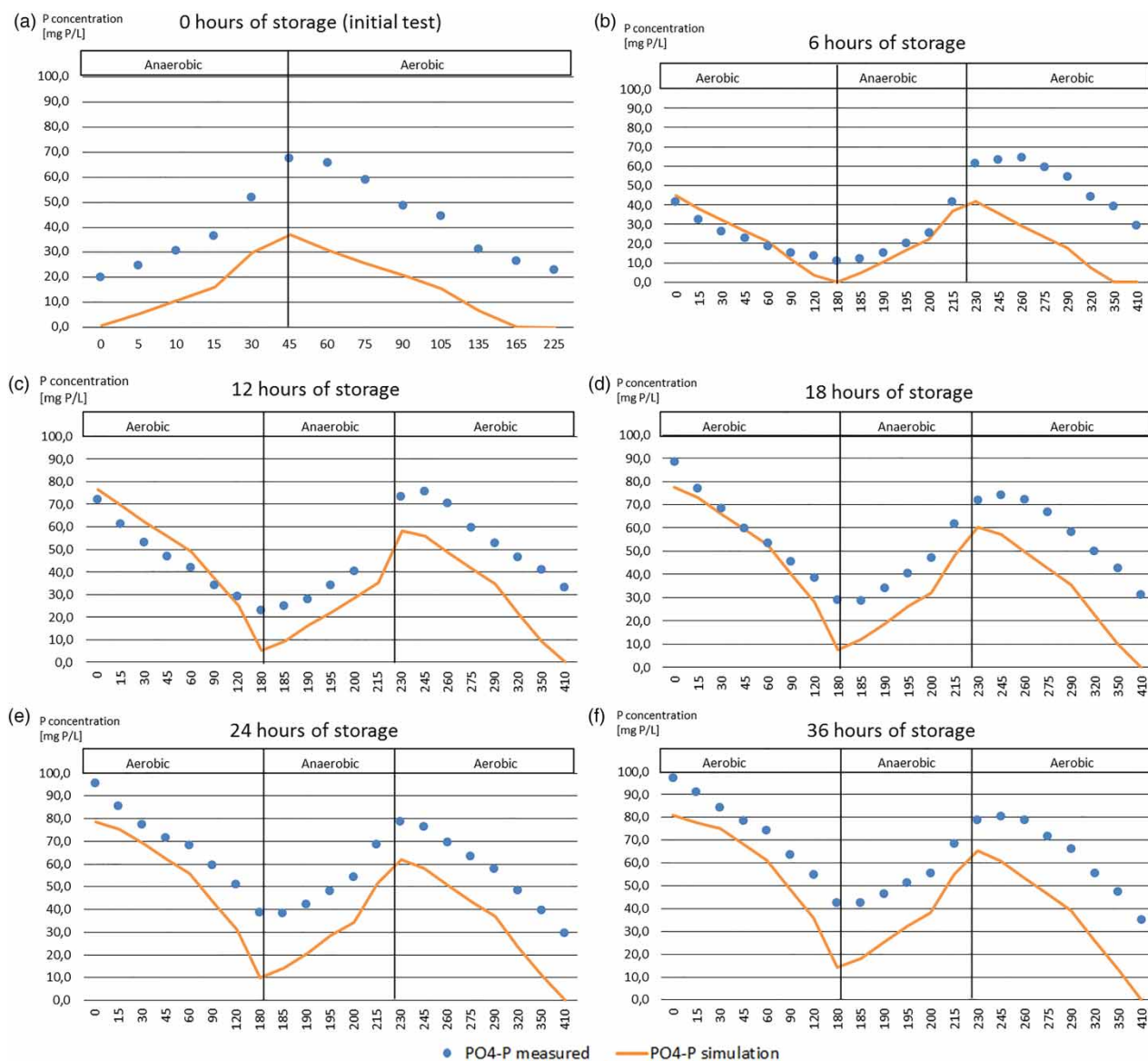

**Figure 6** | (a–f) Phosphorus uptake and release tests with alternating aerobic/anaerobic periods after the indicated anaerobic storage period (X axis represents the time of the experiment in minutes).

Comment citer ce document :

Varga, E., Hauduc, H., Barnard, J., Dunlap, P., Jimenez, J., Menniti, A., Schauer, P., Lopez Vazquez, Gu A. Z., Sperandio, M., Takács (2018). Recent advances in bio-P modelling – a new approach verified by full-scale observations. *Water Science and Technology*, 78 (10), 2119-2130.

DOI : 10.2166/wst.2018.490

Version postprint

the creation of anaerobic conditions during the unaerated phase.

Figure 6(a)–6(f) shows the simulation results for the initial testing, 6-12-18-24-36 hours of storage time, respectively. The initial difference between the simulation and the measured data on Figure 6(a) can be explained with uncertainties regarding the storage prior to the experiments. For the simulation, diluted sludge from AB5 (Westbank) simulation was taken (note that the sampling for the calibration period was not in the same time as the batch test experiments thus differences in the exact sludge composition may occur. That can be the reason for the discrepancies between the maximum phosphorus released in the simulation (~80 mg P/L) vs. the batch test results (~95 mg P/L).

As discussed before, in the new model stored polyphosphate is represented by one variable which allows PAOs to release all stored phosphorus unlike in the Barker-Dold model where a fraction of PP is non-releasable. This may require additional parameter adjustment in order to match the P release and uptake tests.

## SUMMARY

As pointed out by Dunlap *et al.* (2016), a new approach in biological phosphorus removal modeling is necessary in order to successfully simulate S2EBPR configurations that do not depend on the presence of influent VFA.

The proposed PAO-GAO model shows an improvement in bio-P performance prediction due to the introduced processes based on recent research and modified by detecting the extent of anaerobic conditions using an ORP estimator (ORP is estimated for all zones, not only the anaerobic zone). Under normal ORP conditions, up to –100 mV range in anaerobic zones, the model allows the coexistence of PAOs and GAOs. This, through the loss of VFA to non-P removing GAOs, hampers the performance of the bio-P system, as experienced in the A2O configuration.

Under extreme low ORP conditions (lower than –150 to –200 mV) GAOs are disappearing through substrate storage limitation in the model and more stable bio-P performance can be observed in agreement with experimental and full-scale results.

There are conditions where GAOs are able to outgrow PAOs (e.g. under high temperatures), simulating the loss of biological phosphorus removal experienced in plants from time to time even when anaerobic zones are present.

The model, coded in Sumo© was successfully calibrated against typical bio-P plant configurations, as well as detailed

data from Clean Water Services' Rock Creek facility including both full scale operational data and specific batch P release and uptake tests. The full model file (including parameters values etc.) is available at the following link: <http://www.dynamita.com/wp-content/uploads/Sumo1.xlsm>

## ACKNOWLEDGEMENTS

This project was carried out with Sumo© modeling and simulation software (Dynamita 2017) based on the data provided by Clean Water Services (Hillsboro, OR) and Northeastern University (Boston, MA).

## REFERENCES

- Ahn, J., Daidou, T., Tsuneda, S. & Hirata, A. 2001a Metabolic behavior of denitrifying phosphate accumulating organisms under nitrate and nitrite electron acceptor conditions. *Journal of Bioscience and Bioengineering* **92** (5), 442–446.
- Ahn, J., Daidou, T., Tsuneda, S. & Hirata, A. 2001b Selection and dominance mechanisms of denitrifying phosphate-accumulating organisms in biological phosphate removal process. *Biotechnology Letters* **23** (24), 2005–2008.
- Barker, P. S. & Dold, P. L. 1997 General model for biological nutrient removal activated-sludge systems: model presentation. *Wat. Env. Res.* **69** (5), 969–984.
- Camejo, P. Y., Owen, B. R., Martirano, J., Ma, J., Kapoor, V., Domingo, J. S., McMahon, K. D. & Noguera, D. R. 2016 *Candidatus Accumulibacter phosphatis* clades enriched under cyclic anaerobic and microaerobic conditions simultaneously use different electron acceptors. *Water Research* **102**, 125–137. doi: 10.1016/j.watres.2016.06.033.
- Downing, L., Young, M., Cramer, J., Nerenberg, R. & Bruce, S. 2014 Low level DO Operation: Impacts on energy, nutrient and ecology. In: *Proceedings of the 87th Annual Water Environment Federation Technical Conference and Exhibition*.
- Dunlap, P., Martin, K. J., Stevens, G., Tooker, N., Barnard, J. L., Gu, A. Z., Takacs, I., Shaw, A., Onnis-Hayden, A. & Li, Y. 2016 Rethinking EBPR: What do you do when the model will not fit real-world evidence? In: *Presented at the 5th IWA/ WEF Wastewater Treatment Modelling Seminar, Annecy, France*.
- Gu, A. Z., Saunders, A., Neethling, J. B., Stensel, H. D. & Blackall, L. L. 2008 Functionally relevant microorganisms to enhanced biological phosphorus removal performance at full-scale wastewater treatment plants in the United States. *Water Environ. Res.* **80**, 688–698.
- Hauduc, H., Rieger, L., Oehmen, A., van Loosdrecht, M. C. M., Comeau, Y., Héduit, A., Vanrolleghem, P. a. & Gillot, S. 2013 Critical review of activated sludge modeling: state of process knowledge, modeling concepts, and limitations. *Biotechnol. Bioeng.* **110**, 24–46. doi:10.1002/bit.24624.

Comment citer ce document :

Varga, E., Hauduc, H., Barnard, J., Dunlap, P., Jimenez, J., Menniti, A., Schauer, P., Lopez Vazquez, Gu A. Z., Sperandio, M., Takacs (2018). Recent advances in bio-P modelling – a new approach verified by full-scale observations. *Water Science and Technology*, 78 (10), 2119-2130. DOI : 10.2166/wst.2018.490



- Henze, M., Gujer, W., Mino, T., Matsuo, T., Wentzel, M. C., Marais, G. v. R. & van Loosdrecht, M. C. M. 2000 *Activated Sludge Model No. 2d*, IWA Publishing, Scientific and Technical Report No. 9. IWA, London.
- Hu, Z. R., Wentzel, M. C. & Ekama, G. A. 2007 *A general kinetic model for biological nutrient removal activated sludge systems: model development*. *Biotechnology and Bioengineering* **98** (6), 1242–1258.
- Jimenez, J., Dold, P., Du, W. & Burger, G. 2014 *Mainstream Nitrite-Shunt with Biological Phosphorus Removal at the City of St. Petersburg Southwest WRF*. In: *Proceedings of the Water Environment Federation*; doi:10.2175/193864714815942116.
- Jimenez, J., Stensel, D. & Daigger, G. 2017 *Simultaneous nutrient removal through low dissolved oxygen operation: application, pitfalls and design*. In: *WEFTEC 2017 Proceedings*, pp. 1308–1313.
- Keene, N. A., Reusser, S. R., Scarborough, M. J., Grooms, A. L., Seib, M., Domingo, J. S. & Noguera, D. R. 2017 *Pilot plant demonstration of stable and efficient high rate biological nutrient removal with low dissolved oxygen conditions*. *Water Research* **121**, 72–85. doi: 10.1016/j.watres.2017.05.029.
- Kuba, T., van Loosdrecht, M. C. M., Brandse, F. A. & Heijnen, J. J. 1997 *Occurrence of denitrifying Phosphorus Removal Bacteria in modified UCT type wastewater treatment plants*. *Water Research* **31** (4), 777–786.
- Lanham, A. B., Oehmen, A., Saunders, A. M., Carvalho, G., Nielsen, P. H. & Reis, M. A. M. 2014 *Metabolic modelling of full-scale enhanced biological phosphorus removal sludge*. *Water Res.* **66**, 283–295. doi:10.1016/j.watres.2014.08.036.
- Le Moullec, Y., Gentric, C., Potier, O. & Leclerc, J. P. 2010 *Comparison of systemic, compartmental and CFD modelling approaches: application to the simulation of a biological reactor of wastewater treatment*. *Chemical Engineering Science* **65**, 343–350.
- Lopez-Vazquez, C. M., Hooijmans, C. M., Brdjanovic, D., Gijzen, H. J. & van Loosdrecht, M. C. M. 2008 *Factors affecting the microbial populations at full-scale enhanced biological phosphorus removal (EBPR) wastewater treatment plants in The Netherlands*. *Water Res.* **42**, 2349–2360.
- Lopez-Vazquez, C. M., Oehmen, A., Hooijmans, C. M., Brdjanovic, D., Gijzen, H. J., Yuan, Z. & van Loosdrecht, M. C. M. 2009 *Modeling the PAO-GAO competition: effects of carbon source, pH and temperature*. *Water Res.* **43**, 450–462.
- Lu, H., Keller, J. & Yuan, Z. 2007 *Endogenous metabolism of Candidatus Accumulibacter phosphatis under various starvation conditions*. *Water Res.* **41**, 4646–4656.
- Meijer, S. C. F. 2004 *Theoretical and Practical Aspects of Modelling Activated Sludge Processes*. Department of Biotechnological Engineering, Delft University of Technology, The Netherlands, 218.
- Oehmen, A., Lopez-Vazquez, C. M., Carvalho, G., Reis, M. A. M. & van Loosdrecht, M. C. M. 2010 *Modelling the population dynamics and metabolic diversity of organisms relevant in anaerobic/anoxic/aerobic enhanced biological phosphorus removal processes*. *Water Res.* **44**, 4473–4486.
- Rubio-Rincon, F. J., Lopez-Vazquez, C. M., Welles, L., van Loosdrecht, M. C. M. & Brdjanovic, D. 2017 *Cooperation between Candidatus compatibacter and Candidatus Accumulibacter clade I, in denitrification and phosphate removal processes*. *Water Research* **120**, 156–164.
- Schauer, P., Menniti, A. & Maher, C. 2017 *Testing the limits of EBPR for stable operation*. In: *WEFTEC 2017 Proceedings*, pp. 1581–1594.
- Siegrist, H., Brunner, I., Koch, G., Phan, L. C. & Van Le, C. 1999 *Reduction of biomass decay rate under anoxic and anaerobic conditions*. *Water Sci. Technol.* **39**, 129–137.
- Tooker, N. B., Barnard, J. L., Bott, C., Carson, K., Dombrowski, P., Dunlap, P., Martin, K., McQuarrie, J., Menniti, A., Phillips, H., Schauer, P., Shaw, A., Stevens, G., Takács, I., Onnis-Hayden, A. & Gu, A. Z. 2016 In: *Side-Stream Enhanced Biological Phosphorus Removal As A Sustainable And Stable Approach For Removing Phosphorus From Wastewater WEF/IWA Nutrient Removal and Recovery Conference, Denver, CO, USA*.
- Tooker, N. B., Li, G., Bott, C., Dombrowski, P., Schauer, P., Menniti, A., Shaw, A., Barnard, J. L., Stinson, B., Stevens, G., Dunlap, P., Takacs, I., Phillips, H., Analla, H., Russell, A., Ellsworth, A., McQuarrie, J., Carson, K., Onnis-Hayden, A. & Gu, A. Z. 2017 *Rethinking and reforming Enhanced Biological Phosphorus Removal (EBPR) Strategy – Concepts and mechanisms of Side-stream EBPR*. In *WEFTEC 2017 Proceedings*, pp. 2547–2564.
- Welles, L., Abbas, B., Sorokin, D. Y., Lopez-Vazquez, C. M., Hooijmans, C. M., van Loosdrecht, M. C. M. & Brdjanovic, D. 2017 *Metabolic response of ‘Candidatus accumulibacter phosphatis’ clade II C to changes in influent P/C ratio*. *Frontiers in Microbiology* **7**, 2121. doi:10.3389/fmicb.2016.02121cc.

First received 30 June 2018; accepted in revised form 16 November 2018. Available online 4 December 2018

Comment citer ce document :

Varga, E., Hauduc, H., Barnard, J., Dunlap, P., Jimenez, J., Menniti, A., Schauer, P., Lopez Vazquez, C. M., Sperandio, M., Takács (2018). Recent advances in bio-P modelling – a new approach verified by full-scale observations. *Water Science and Technology*, 78 (10), 2119–2130.