

Optical Engineering

OpticalEngineering.SPIEDigitalLibrary.org

Investigation of combined optical and thermal effects on phosphor converted light-emitting diodes with liquid immersion cooling

Halil Ibrahim Kahvecioglu
Enes Tamdogan
Mehmet Arik

SPIE.

Halil Ibrahim Kahvecioglu, Enes Tamdogan, Mehmet Arik, "Investigation of combined optical and thermal effects on phosphor converted light-emitting diodes with liquid immersion cooling," *Opt. Eng.* **57**(5), 055101 (2018), doi: 10.1117/1.OE.57.5.055101.

Investigation of combined optical and thermal effects on phosphor converted light-emitting diodes with liquid immersion cooling

Halil Ibrahim Kahvecioglu,^{a,*} Enes Tamdogan,^b and Mehmet Arik^a

^aOzyegin University, Department of Mechanical Engineering, Istanbul, Turkey

^bTAI—Turkish Aerospace Industries Inc., Istanbul, Turkey

Abstract. The inclusion of phosphor into a high brightness light-emitting diode (LED) package is a complicated task since LEDs are encapsulated with a phosphor and epoxy mixture to convert blue photons to white light. Moreover, this common practice may cause high temperatures and fractures in the gold wire bonds of the chip or solder balls due to local heating and thermal stresses leading to device failures. Furthermore, at elevated junction temperatures, the light conversion efficiency of the phosphor reduces and decreases the overall optical efficiency of an LED. Although, remote phosphor technique has been already applied to LED systems, the high power requirements have needed better performing methods. Thus, an immersion liquid cooled remote phosphor-coated system has been proposed and experimentally and computationally investigated. First, a set of experiments was performed, which includes the combined effects coming from both optical and thermal improvements with the proposed liquid cooled remote phosphor-coated technique, where the total light extraction enhancement was obtained in excess of 25%. Then, the same problem has been computationally studied for investigation of solely optical enhancements, which has shown that remote phosphor-coated LED package with a liquid coolant of suitable refractive index at the optical path has enhanced the overall lumen performance about 13%, whereas the rest of the improvements of 12% were due to thermal enhancements. © 2018 Society of Photo-Optical Instrumentation Engineers (SPIE) [DOI: 10.1117/1.OE.57.5.055101]

Keywords: light-emitting diode efficiency; light-emitting diode optics; remote phosphor coating; liquid cooling.

Paper 172039 received Dec. 23, 2017; accepted for publication Apr. 10, 2018; published online May 8, 2018.

1 Introduction

Phosphor converted white-light emitting diodes (PC-LEDs) have been widely used in lighting applications due to their efficiency, low energy consumption, small size, exceptional color quality, long life, and low production cost.^{1–3} The most common method is to use blue chip with phosphor coating over the LED die or remote phosphor in order to produce white light. Blue light emitted from a LED at short wavelengths is absorbed and re-emitted as yellow in longer wavelengths in PC-LEDs. Thus, some parameters, such as absorptivity of optically transparent element, refractive index (n) matching, phosphor concentration, particle size, and thickness, have significant impacts to determine light output.⁴ To be able to capture the effects of all those parameters, the computational software uses the Monte Carlo method for the entire LED model for ray tracing of light particles, whereas the Lorenz Mie theory is used for spatial distribution of photons in the phosphor for the particle size parameter in the Mie (visible) region.⁴

However, a small portion of the electrical input power can be converted to light while the rest stays inside the chip or phosphor particles as undesired heat generation due to absorption, reflection, electrical efficiency etc. Furthermore, this undesired heat generation can also happen due to low quantum efficiency and Stokes shift during the conversion

of light in the phosphor layer. While the quantum efficiency is defined by the ratio of emitted photons to absorbed photons in phosphor, Stokes shift is the conversion of higher energy shorter wavelength photons to lower energy longer wavelength photons. Thus, lower conversion efficiencies cause to local high temperatures at the phosphor layer that lead to a decrease in the quantum efficiency of phosphor exponentially inducing local stress and even delamination, and ultimately degrading reliability and lifetime.^{5–8} Although the heat generation is higher on the chip level compared to phosphor layer, phosphor particles may reach higher temperatures in LED systems^{9,10} due to low thermal conductivity of phosphor and mixed elastomer (silicone, epoxy, etc). Therefore, a better heat removal method is preferred to distribute and remove the heat from system to ambient.^{11–14}

The impact of immersion cooling with an optically superior fluid is investigated to enhance both optical and thermal characteristics leading to a higher lumen extraction and longer lifetime. A series of experimental studies has been performed in a liquid cooled PC-LEDs system, and the results have been compared with computational studies in the following sections of the current study.

2 Experimental Study

An experimental system has been designed and built for the current study. Blue gallium nitride (GaN) chips (CREE EZ1000) are used as test vehicles.¹⁵ Figure 1 presents the

*Address all correspondence to: Halil Ibrahim Kahvecioglu, E-mail: ibrahim.kahvecioglu@outlook.com

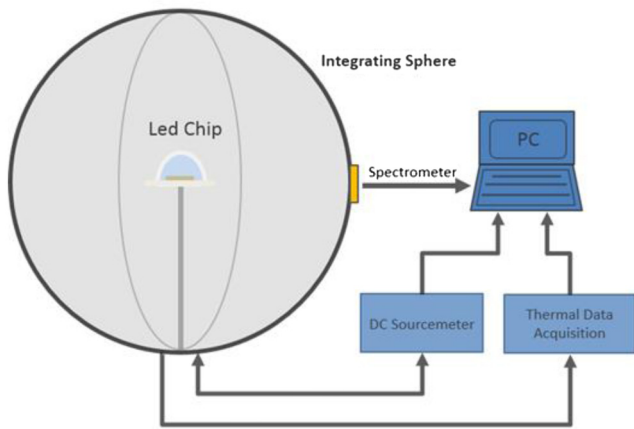

Fig. 1 Schematic of the experimental system.

experimental system consisting of a DC sourcemeater, a set of temperature sensors (T type thermocouples), and an integrating sphere for optical measurements, such as radiant power, lumen, color rendering index (CRI), correlated color temperature (CCT), and spectral power distribution (SPD).

The immersion liquid cooled remote phosphor-coated LED package test device construction levels [(a) bare chip, (b) glass dome addition, and (c) remote phosphor coating LED] are presented in Fig. 2. Over the printed circuit board (PCB), a special ceramic enclosure (3×3 mm) surrounds the blue LED die for protection and two holes with valves were used for liquid injection. To be able to fill dielectric liquid and have the phosphor layer coated remotely, a special glass dome with a radius of 10 mm and a thickness of 1.5 mm has been manufactured and used over the LED package, as shown in Fig. 2.

Optical measurement results were first investigated for blue chip [Fig. 2(a)], followed by blue chip with glass dome [Fig. 2(b)], and finally remote phosphor-coated glass dome [Fig. 2(c)]. This methodology will provide the baseline result with blue chip and then the effect of glass dome in a structured order. Finally, applying phosphor coating under the glass dome and injecting liquid coolant will enable the goal of this project. In order to study the effects of combined phosphor and liquid cooling materials, the inner surface of the glass was coated with a YAG:Ce phosphor mixture of 16% by weight, with a thickness of 1 mm, and then it was filled with a dielectric liquid coolant called LS5238 with a refractive index (n) of 1.38 via injection holes.^{16,17} Then, the

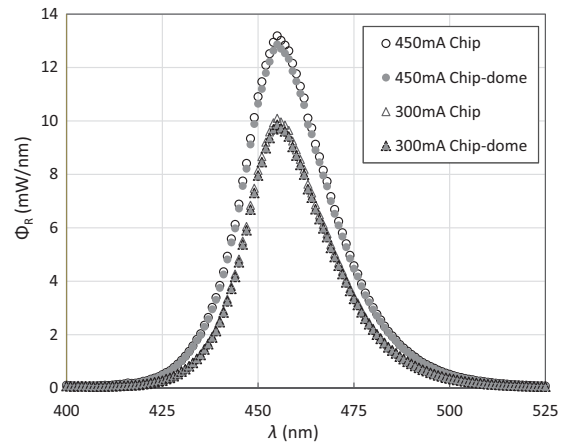

Fig. 3 Spectrum of blue LED chip with and without glass dome for 300 to 450 mA currents.

optical measurements for obtaining radiant power, lumen, CRI, CCT, and spectral distribution were performed with an integrated sphere (2-m diameter). To have an accurate comparative study, the chips were driven at two different currents (300 and 450 mA), and each test was repeated three times. The average of the last 10 measurements were taken and saved when the system has reached to steady state.

Figure 3 presents the spectral distributions of LED packages before and after mounting the glass dome, where a small decrease on light extraction due to the back reflection of the glass dome has been observed. As the peak wavelengths of the spectrums are measured as 454.9 nm, the full width half maximum (FWHM) values are 24.7 and 25.5 nm at 300 and 450 mA driving currents, respectively. However, CCT value for blue chip with and without glass is obtained as 22,000 K, whereas CRI of the chip with and without glass was measured ~ 52 for blue light. Furthermore, luminous flux and optical power results for chip-glass dome are given in Table 1 before phosphor coating.

Then, the same experiments were conducted for the remote phosphor coated [Fig. 2(c)] with and without dielectric liquid coolant. After phosphor coating, light intensity at the peak wavelength decreased from 13 (W/nm) to 1.5 (W/nm) for 450-mA driving condition (see Fig. 3). Although the optical power emitted from the remote phosphor coated LED decreased (see Table 1), the higher wavelength light emission leads to a lumen increase due to the sensitivity of eye to these colors. While the peak wavelength of phosphor

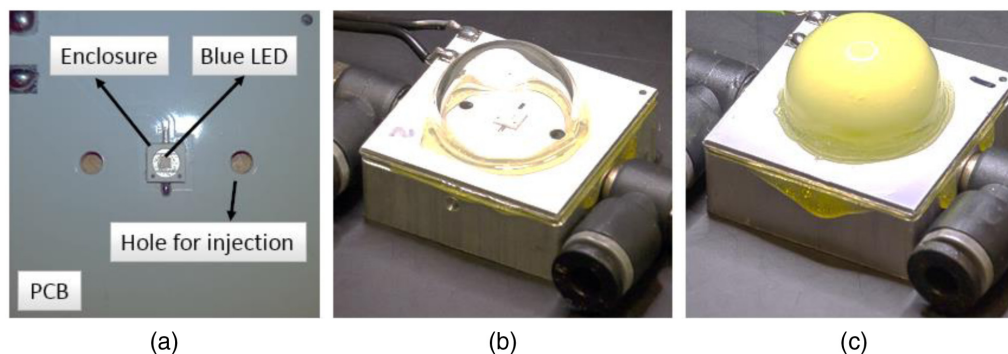

Fig. 2 (a) Bare chip, (b) glass dome, and (c) remote phosphor LED package with liquid coolant.

Table 1 Lumen and radiant power before and after phosphor coating.

	300 mA		450 mA	
	Luminous flux (lm)	Optical power (W)	Luminous flux (lm)	Optical power (W)
Before phosphor coating	15.16	290.9	20.42	394.4
After phosphor coating	62.55	148.7	83.99	201.3

emission is measured as 544.4 nm for both currents (300 and 450 mA) in the integrating sphere, CCT values are 4053 and 4046 K and CRI values are 53.7 and 54.2, respectively.

Optically transparent liquid has then been injected through the holes and the two valves are closed. Through the liquid injection, both the chip and the phosphor temperatures are expected to be lower due to the enhanced natural convection with optically transparent liquid, which is in direct contact with the chip and the remote phosphor. Thus, an extra enhancement in lumen output was observed due to the temperature drop over the optical path.¹⁸ Spectral power between 400 and 750 nm was measured before and after optically transparent liquid injection at the optical path. The experimental results have shown an increase in the lumen output of remote phosphor-coated system due to a higher sensitivity of normal human eye in the visible spectrum. The remote phosphor liquid cooled system has shown a better optical light extraction than the remote phosphor-coated system because the refractive index mismatching among phosphor, silicon, and air is eliminated by injection of the liquid into the hole. CCT results slightly changed to be 4098 and 4091 K, whereas the CRI values are 55.4 and 55.8 at 300 and 450 mA, respectively by the injection. Moreover, the liquid has increased the efficiency in PC-LEDs due to thermal enhancement, although the chosen optically transparent liquid has a higher absorption than air inside the glass dome.

3 Optical Modeling

To validate experimental findings, numerical models have been built with a commercial optical simulation program Lighttools.¹⁹ Luminous flux, radiant power, CRI, CCT, and spatial distributions of each case were simulated in order to get results of optical effects, such as reflection, absorption, etc. The computational model for the immersion liquid cooled remote phosphor-coated LEDs, as shown in Fig. 4, consists of several components: 1.6-mm thick metal core PCB and an LED package, which is placed on the PCB with ceramic enclosure (3 × 3 mm²). As in the test specimen, the LED chip is then covered with a hemispherical dome with an outer radius of 1 cm and a thickness of 1.5 mm. To have an accurate comparison between the experimental study and simulations, boundary conditions, such as refractive index (*n*), complex refractive index (*k*), reflectivity (Re), and transmissivity (Tr), have been set according to test specimens, which are listed in Table 2. Moreover, the SPDs of the blue LED measured in the integrating sphere were used as the light source in the simulations, which has a wavelength region of 400 to 750 nm and 457-nm peak wavelengths with a FWHM values of 24.7 and 25.4 for 300 and 450 mA, respectively.

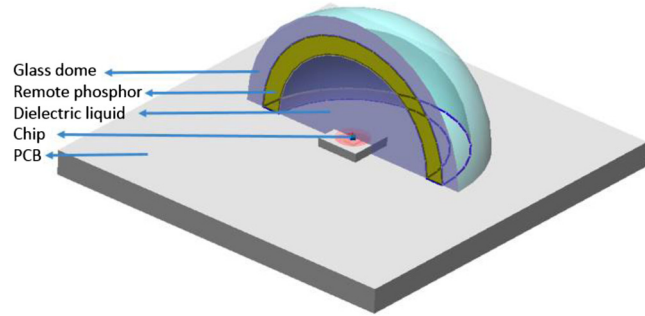

Fig. 4 Computational model used to study optical effects of glass dome, phosphor coating, and liquid coolant.

Once the chip is covered by the transparent glass dome, reflection (Fresnel) loss due to refractive index difference and absorption loss are taken into account, since they are the main reasons for lumen decrease and need to be well defined in the optical simulations. Accordingly, the absorption coefficients for glass dome and optically transparent liquid were measured by the spectrometer. Fresnel loss is defined for the case of normal incidence at the angle 0 as in Eq. (1) given below, where *R* is reflection loss and *n* is refractive index. It can be easily observed that the reflection loss increases when the refractive index difference increases between the media according to the equation. Thus, materials with low refractive index difference should be selected to reduce optical losses between media. Air gaps in the optical path can lead the reflection loss to increase significantly:

$$R = \left| \frac{n_1 - n_2}{n_1 + n_2} \right|^2 \tag{1}$$

In addition to Fresnel loss, absorbance, which is defined in Eq. (2), was measured by the spectrometer for the glass dome and liquid. In Eq. (2), *A* is absorbance, *I* is calculated optical power, and *I*₀ is initial optical power. Optical power was calculated in the simulations through the thickness *x* by Lambert–Beer’s law in Eq. (3). According to this rule, light intensity attenuates in the material, and this energy is lost in such media as glass and liquid. Phosphor particles also absorb and convert blue light into yellow light in a wider spectrum and produce heat in phosphor layer. These energy conversions have been calculated in the simulations:

Table 2 Boundary conditions for the domain of analysis.

	<i>n</i>	<i>k</i>	Re	Tr
Chip	2.42	—	—	—
Enclosure	—	—	0.8	—
PCB	—	—	0.7	—
Glass	1.52	0	—	0.9
Phosphor layer	1.60	1.8 × 10 ⁻⁶	—	—
Liquid	1.38	0	—	1.0
Air	1	0	—	1.0

$$A = \log_{10} \left(\frac{I_0}{I} \right), \quad (2)$$

$$I = I_0 \exp[-\log(10)Ax]. \quad (3)$$

The refractive index and the transmittance were set as 1.52 and 90% for glass, respectively.⁴ Cerium-doped yttrium aluminum garnet phosphor (YAG:Ce) usually has a constant refractive index of 1.82. However, after mixing with silicone, the refraction index (n) of phosphor mixture is calculated as 1.60 based on the linearity formula. The percentage by weight of the YAG:Ce phosphor-silicon mixture was set to 16%. Particle size ratios of phosphor particles are chosen to be 20%, 30%, 30%, and 20% with the sizes of 9, 11, 13, and 15 μm , respectively.³ However, phosphor particles also absorb and convert blue light to yellow light with a conversion efficiency, as shown in Eq. (4). Phosphor in this process produces heat due to Stokes shift, which is the ratio of wavelength (λ) of absorbed photon to emitted photon, and due to quantum efficiency, which is defined by the ratio of number of emitted photons to absorbed photons:

$$n_{\text{phos}} = \frac{hc/\lambda_{\text{emitted}}}{hc/\lambda_{\text{absorbed}}} \frac{N_{\text{emitted}}}{N_{\text{absorbed}}} = \frac{\lambda_{\text{absorbed}}}{\lambda_{\text{emitted}}} \frac{N_{\text{emitted}}}{N_{\text{absorbed}}}, \quad (4)$$

where c is speed of light and h is Planck's constant. Phosphor ray scattering parameters—mean free path, absorption cross section, scattering cross section, extinction cross section, and unconverted ray distributions—were determined by using Mie theory. The energy conversions have been computationally calculated with Lighttools according to Mie scattering-distribution theory.

Mie scattering is used for the situations, where the size of the scattering particles is comparable to the wavelength of the light, rather than much smaller or much larger. In our computational study, the peak wavelength of blue light and average phosphor size are 457 nm and 10 μm , which are relatively comparable, thus phosphor mean free path and distribution of unconverted rays were simulated based on Mie theory. Both remote phosphor-coated system with

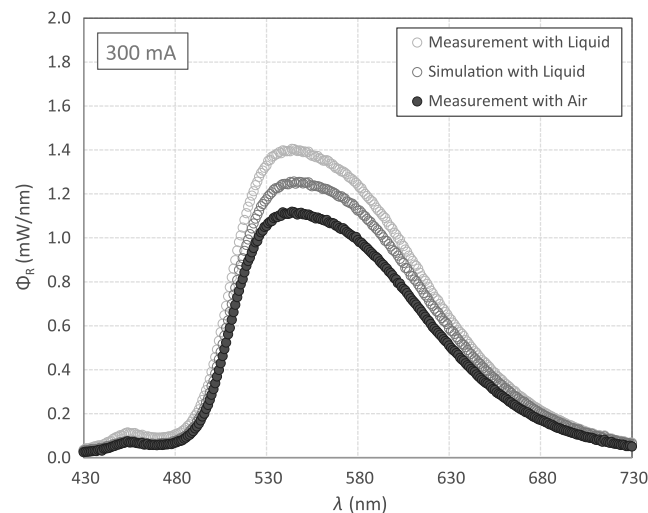

Fig. 5 Simulation and experimental results for liquid injected cases under 300 mA.

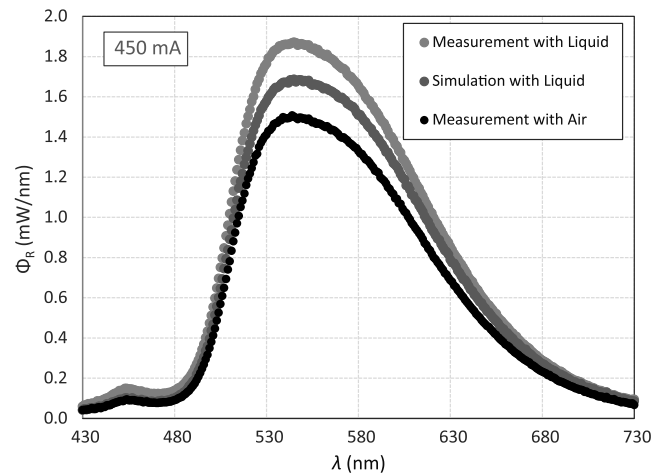

Fig. 6 Simulation and experimental results for liquid injected cases under 450 mA.

and without liquid coolants have then been simulated for the driving currents of 300 and 450 mA.

Optical enhancement with liquid injected remote system can be seen in Figs. 5 and 6 for 300- and 450-mA input current. Since the simulation software deals solely with optical effects neglecting thermal impact, we can see the optical effects from the shift enhancements in the figures. However, in the measurements, liquid dissipates heat easily, as a result, chip and phosphor temperature are expected to decrease and obtain higher lumen output. Due to the difference between the experiments and computational studies, we can further derive the thermal effects on the LED performance.

4 Results and Discussions

In LED packaging systems, which are not remote coated, the blue light generated by the LED chip emits photons. Some of these light rays absorbed by the phosphor coated on the LED chip are downconverted and produce extra heat. In comparison, in a remote-phosphor system, the phosphor is placed far from the LED chip. Since the LED chip is located a further distance, the maximum temperature of phosphor layer and chip are decreased. Moreover, the overall efficiency in a remote phosphor with immersion cooling system will be higher than a typical near coated and remote coated phosphor LEDs due to thermal and optical reasons. Moreover, a dielectric liquid coolant serves as an extra coolant and better refractive index matching for LEDs.

First, an experimental study was performed to obtain the initial optical values of blue GaN-based chip under two different currents. Then, the LED light output (bare chip, bare chip with glass dome, remote phosphor-coated air filled system, and remote phosphor-coated dielectric liquid filled system) was examined computationally. The initial lumen outputs obtained from experimental study for the blue chip at the 300 and 450 mA driving currents are 15.56 and 20.99 lm, respectively. By adding the glass dome, luminous flux in the experiment has decreased to 15.16 and 20.42 lm, which means 2.6% and 2.7% luminous flux drop. However, the calculated luminous fluxes were recorded as 14.55 and 19.61 lm, which corresponds to an average of 6.5% drop. Adding glass dome has dropped luminous flux less than expected due to the effect of thermal effects in the experiments.

Table 3 Luminous flux comparisons of computational and experimental results.

	Measurements (lm)			
	300 mA		450 mA	
Bare chip	15.56		20.99	
Remote phosphor	62.55		83.99	
	Simulations		Measurements	
	300 mA	450 mA	300 mA	450 mA
Chip with glass dome	14.55	19.61	15.16	20.42
Liquid injected	70.74	94.98	78.84	105.02

Thus, thermal effects on the light extraction have been obtained by comparing the computational and experimental results. While glass dome causes loss due to Fresnel reflection and absorption, it may increase the thermal performance due to higher heat dissipation. Thus, we have seen a thermal effect of the glass dome almost 4%.

Experimental results of remote phosphor-coated LED were used to compromise the luminous fluxes with simulations. The calculations can have high uncertainty due to the complex relationship between temperature and the conversion factors, such as absorption and extinction coefficients. The luminous fluxes after phosphor coating are increased to 62.55 and 83.99 for the driving currents 300 and 450 mA, respectively, although optical radiant power decreased. It is almost increased four times via the phosphor coating. The reason is the spectrum shift of the blue light into longer wavelengths in which normal human eye has a higher sensitivity to these photons.

In the next step, optical and thermal effects of liquid coolant have been studied. Air gap was filled by optically transparent liquid by two valves with liquid LS5238 (refractive index of 1.38) decreasing the difference of refractive indices of layers. After the liquid injection in the simulated model, lumen output has enhanced to 70.74 and 94.98 for 300 and 450 mA, respectively, as already shown in Table 3. However, in the experiments, luminous fluxes have enhanced to 78.84 and 105.02.

In the experimental study, higher luminous fluxes have been obtained because the injected dielectric liquid has shown a better heat dissipation than air. The temperature drop in the LED chip and remote phosphor layer has enhanced the efficiency in the chip and the phosphor layer. The effect of liquid coolant in the remote phosphor system can be seen in the SPD diagrams of simulations and measurements for the given currents (Figs. 5 and 6). Radiant powers in the visible region between 430 and 730 nm have been enhanced for both the given currents.

We have obtained almost 26% and 25% enhancement for 300 and 450 mA currents, respectively, during experiments, as shown in Fig. 7. However, in the simulations, the optical effects were found to be about 13% (see Fig. 8). Thus,

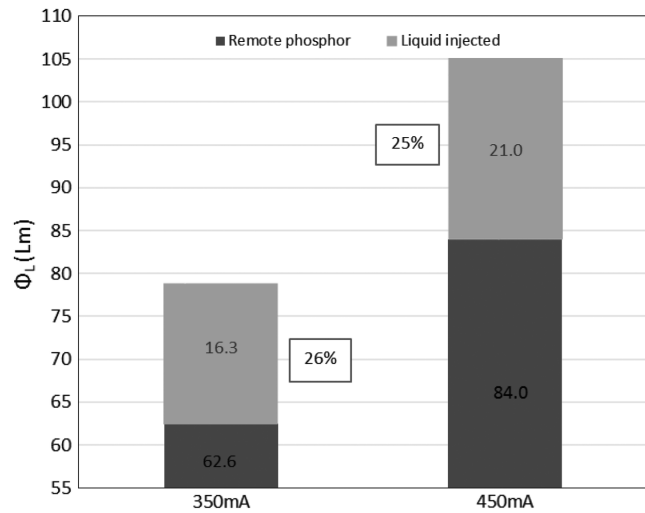
**Fig. 7** Lumen enhancement of liquid coolant.

thermal enhancement effects have been obtained 13.0% to 11.9% by extracting the optical results from the experimental results given in Fig. 8. Thermal effects have increased the lumen output by almost 13% for 300 mA. However, at the higher driving current (450 mA), thermal effect is almost 12%.

Spatial optical enhancements were also investigated for each construction level of LED packages. In Fig. 9, significant enhancements have been shown in the polar diagrams of light intensities for 300 and 450 mA, respectively. The effects of phosphor coating, and optical and thermal enhancements of liquid can be clearly seen in the diagrams. The spatial light intensities were increased due to the phosphor layer, and then the liquid coolant has enhanced lumen output most after phosphor layer. Maximum light intensity for 300 mA is about 5.11 and 4.85 candela (cd) for the chip and glass dome, respectively. While the intensity of phosphor-coated LED is 21.15 cd, liquid filled LED package has reached to a maximum of 22 cd. For 450-mA driving condition, maximum intensities for bare chip, chip with glass dome, phosphor coated, and liquid injected LED have been found to be 7, 6.62, 28.40, and 29.56 cd, respectively, in the optical simulations. It can be seen that light distributions

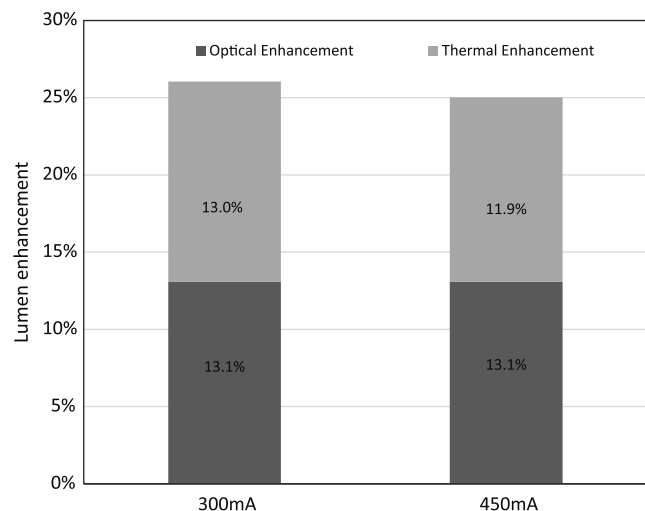
**Fig. 8** Lumen enhancement due to optical and thermal effects.

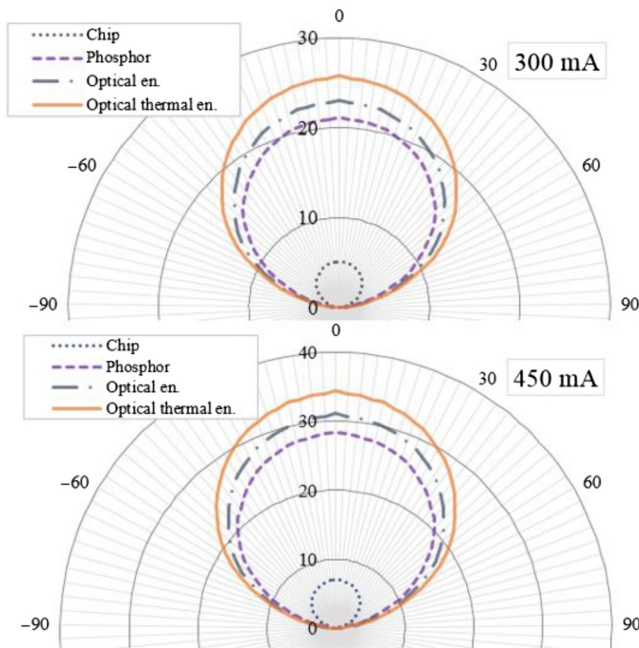

Fig. 9 Light intensity enhancement in spatial polar diagrams for 300 and 450 mA.

considerably changed since phosphor light conversion remained similar to cosine distribution.

About the light characteristics after optically transparent liquid, it has been obtained that CCT increased from 4053 and 4046 K to 4098 and 4091 K, and it was shifted toward blue in the spectrum. CRI has also increased from 53.7 and 54.2 to 55.4 and 55.8 due to using optically transparent liquid instead of air gap between chip and remote phosphor. From Table 1, we can see that 50% of the optical power has lost in the remote phosphor and that lead to temperature increase in the layer. Liquid cooling, thus, has advanced CRI measurements of the LED.

We have obtained nearly 13% light extraction enhancement with a refractive index of 1.38, as shown in Fig. 8. For a better understanding of the refractive index (n) over optical

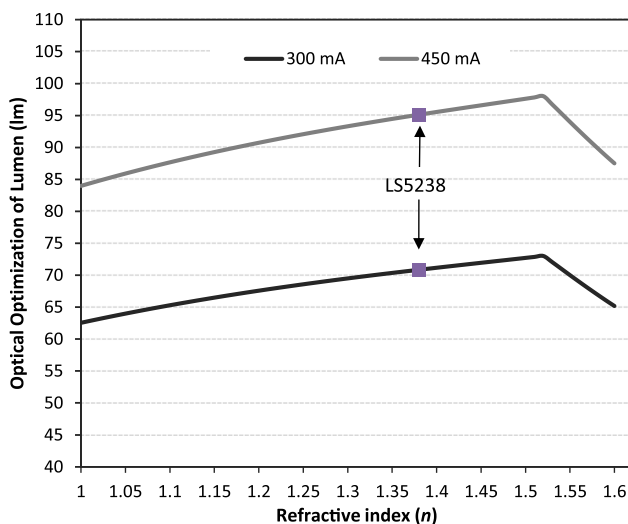

Fig. 10 Optical optimization analysis of the refractive index (n) of liquid.

characteristics, a further study has been performed for a refractive index range of 1 and 1.6. Lumen output has increased continuously with an increasing n up to 1.53, then it has started to decrease, as shown in Fig. 10, for both 300 and 450 mA. At that point, lumen output in the liquid injected LED has increased from 70.74 and 94.98 to 73.0 and 98.03 lm, respectively. It corresponds to 3.6% more light extraction by decreasing Fresnel reflection losses between the media of remote phosphor-coated LED. About 16.7% optical enhancement could be achieved due to lowering reflection losses in the LED.

5 Summary and Conclusions

A fundamental study of optical and thermal management aspects of remote phosphor-coated liquid injected LED has been performed. Blue LEDs, later packaged with a glass dome, remote phosphor, and transparent liquid, have been tested in an integrating sphere. Lumen outputs, spectral distributions, energy losses, and efficiencies of the package have been experimentally investigated in order to study optical and thermal effects before and after injecting optically transparent liquid into the LED system. Moreover, in the optical model, blue LED lumen output, spectral power distributions, energy losses, efficiencies, spectral changes, and polar distributions have been computationally investigated in order to study optical effects. We have seen that both optical and thermal effects of liquid have a combined augmentation of 25.5% lumen output on the optically transparent liquid injected PC-LED. The optical effect of liquid injection has enhanced the lumen output by almost 13%, and thermal effects have been found \sim 12.5% in the LED package.

Acknowledgments

Authors would like to thank to Ozyegin University EVATEG Center for providing access to laboratories and computational resources during this research.

References

1. F. Steranka, J. Bhat, and D. Collins, "High power LEDs-technology status and market applications," *Phys. Status Solidi A* **194**(2) 380–388 (2002).
2. M. R. Krames et al., "Status and future of high-power light-emitting diodes for solid-state lighting," *J. Disp. Tech.* **3**(2), 160–175 (2007).
3. Y. Narukawa et al., "Recent progress of high efficiency white LEDs," *Phys. Status Solidi A* **204**(6), 2087–2093 (2007).
4. V. Leung, A. Lagendijk, and T. Tukker, "Interplay between multiple scattering, emission, and absorption of light in the phosphor of a white light-emitting diode," *Opt. Express* **22**(7), 8190–8204 (2014).
5. M. Zachau et al., "Phosphors for solid state lighting," *Proc. SPIE* **6910**, 691010 (2008).
6. P. F. Smet, A. B. Parmentier, and D. Poelman, "Selecting conversion phosphors for white light-emitting diodes," *J. Electrochem. Soc.* **158**(6), R37–R54 (2011).
7. S. Ye et al., "Phosphors in phosphor-converted white light-emitting diodes: recent advances in materials, techniques and properties," *Mater. Sci. Eng.: R: Rep.* **71**, 1–34 (2010).
8. M. N. Tsvetkova et al., "Study of photo phosphors for white LEDs," *J. Opt. Technol.* **78**(6), 403–407 (2011).
9. M. Arik, J. Petroski, and S. Weaver, "Thermal challenges in the future generation solid-state lighting applications: light emitting diodes," in *Proc. of the ASME/IEEE ITherm-Conf.*, San Diego (2002).
10. M. Arik et al., "Effects of localized heat generations due to the color conversion in phosphor particles and layers of high brightness light emitting diodes," in *ASME/IEEE Int. Electronic Packaging Technical Conf. and Exhibition InterPACK'03*, 6–11 July, Hawaii (2003).
11. Y. S. Liulin et al., "Thermal analysis of high power LED array packaging with microchannel cooler," in *7th Int. Conf. on Electronic Packaging Technology (ICEPT'06)*, 26–29 August, Shanghai (2006).
12. L. Xiaobing and S. Liu, "A closed micro jet cooling system for high power LEDs," in *7th Int. Conf. on Electronic Packaging Technology (ICEPT'06)*, 26–29 August, Shanghai (2006).

13. C. Adam, M. Ha, and S. Graham, "Thermal management methods for compact high power LED arrays," *Proc. SPIE* **6669**, 66690Z (2007).
14. S. Owen et al., "On-chip power generation using ultra-thin thermoelectric generators," *ASME J. Electron. Packaging* **137**(1), 011005 (2014).
15. Cree, Inc., <http://www.cree.com/led-chips/products/ez-n-leds/ez1000-n> (24 April 2018).
16. <http://www.intematix.com/uploads/phosphor-datasheets/Aluminate/GAL550-02-13.pdf>.
17. http://lookpolymers.com/polymer_NuSil-Lightspan-LS-5238-Silicone-Optical-Fluid.php.
18. E. Tamdogan and M. Arik, "Natural convection immersion cooling and optical degradation of liquid cooled LED systems," *ASME J. Electron. Packaging* **137**(4), 041006 (2015).
19. <https://optics.synopsys.com/lighttools/>.

Halil Ibrahim Kahvecioglu obtained his BSc degree in physics from Bogazici University, İstanbul, Turkey. Then, he started his MSc degree in the Mechanical Engineering Department at Ozyegin University. He is working on EVATEG center as an optical engineer in Ozyegin University. His research areas are optics, SSL lighting, and energy efficiency.

Enes Tamdogan obtained his BSc degree from Uludag University, MSc degree from Brandenburg University of Technology and PhD degree from Ozyegin University in mechanical engineering. His major research areas are direct-indirect liquid cooling, heat transfer on structured surfaces, single and multiphase convection. While he has participated in a variety of projects in USA (GaTech), Germany (TU Cottbus, TU Clausthal), and Turkey (EVATEG, OZU), he is currently leading a group working on military projects in Turkish Aerospace Industry.

Mehmet Arik completed his PhD degree at the University of Minnesota, United States. He has worked at the GE Global Research Center between 2000 and 2011. He is the director of EVATEG Center and a professor of Department of Mechanical Engineering at Ozyegin University in 2011. His current research focuses on energy, medical, electronics, defense and SSL technologies. He serves as an associate editor for *IEEE Components and Packaging Technologies* and *ASME Journal of Electronics Packaging*. He is an ASME fellow.