

Diagnostics of bearings of wheels of cars with the use of noise-acoustic control methods

Dmytro Shmatko, Vladimir Averyanov, Alexander Sasov, Oleg Cherneta

Dnipro State Technical University, Dniprobudivska str., 2, Kamianske, Ukraine, 51918, zombizon@yandex.ua

Abstract: In the given work the method of noise-acoustic non-destructive control during carrying out of diagnostics of bearings of rolling of mats of wheels of cars is considered. The proposed non-destructive method of control provides an opportunity to check the efficiency of the selected lubricant, thereby increasing the life and performance of the bearings. A laboratory installation for the diagnosis of roller bearings has been created, which allows to obtain their acoustic parameters depending on the load of the bearing unit, the time of application and application of different types of lubricants in bearings. The mathematical model developed by the authors is aimed at determining the degree of wear of bearing shafts and allows them to predict their possible work life based on the received noise-acoustic parameters.

Keywords: bearing, non-destructive control, diagnostics, acoustic parameters, lubricants, laboratory setting.

1. Introduction

The resource of cars is determined, basically, by the rolling bearings resource. Defects in the manufacture and operation of bearings in different ways affect the signal of vibration and have different diagnostic features. This allows detecting defects at the stage of their occurrence and predict further development. The manufacturing defects include: deflection of the form in the fabrication of rolling bodies, unbalanced rings, eccentricity of the wraps, radial gaps; violation of roughness of rolling surface. The defects of installation include: defects of planting bearings in the nest; strong drag; wrong centering.

The main reasons for the release of the bearing are: failure of lubrication (40%); violation of the montage (30%); other causes (20%); natural wear (10%) [1].

The acoustic method of non-destructive control is based on the use of waves and elastic oscillations. When acoustic control is usually used oscillations with a frequency of 0, 5 ... 25 MHz (ultrasound) [2]. Therefore, most acoustic techniques are ultrasound, although there are known cases of use and oscillation of the sound frequency. Currently, four methods of ultrasound evaluation of the technical condition of rolling bearings are used in practice: the Peak-factor, the direct spectrum, the spectrographs and shock impulses.

The purpose of the work is to develop a method for carrying out research on the performance of rolling bearings by the method of acoustic non-destructive testing and obtaining the dependencies of acoustic performance of bearings on their development, as well as the use of lubricants in them. Development of a mathematical model, which involves evaluating the bearing of the rolling bearing, depending on its acoustic parameters.



2. Analysis of literature

Many scientists are involved in the diagnostics of parts and units of automobiles using non-destructive methods of control. Much attention is paid to the diagnosis of roller bearings.

So in [3] the authors proposed a method for diagnosing bearings, which involves the use of deformation measurements obtained with the help of fiber optic sensors, which allows to estimate damage by measuring the size of small chips in the bearings of bearings. Using this method it is not possible to determine the degree of bearing of the bearing, but only to assess the degree of damage to its internal and external cartridges.

Work [4] is devoted to the method of evaluation of the quality of lubricants, namely the determination of contamination in the lubrication of rolling bearings using acoustic emission signals. The authors of the article argue that the signature of the contaminated lubricant is much stronger than the effect on conventional state indicators, such as RMS. However, a comprehensive evaluation of the application of one or another lubricant in the roller bearing does not provide for the proposed method.

Proposed in [5], the methodology for the diagnosis of rolling bearings uses packet wavelet transformation, tracking the order and the approach to modeling the features for generating the diagnostic metric as a measure of difference. The disadvantages of this method of diagnostics include its great complexity (it is necessary to carry out the assessment of the distribution of the probability of the diagnostic metric, which is statistically determined in the relevant conditions of use), as well as some inaccuracy in the evaluation of bearing applications with or without lubricants.

The proposed method for the diagnosis of bearings [6] involves obtaining parameters using the method of vibration. This method of variable structure was used to improve the reliability of the malfunctioning while simultaneously reducing the uncertainty in the feedback linearization observer. The main disadvantage of diagnosing with the linearization method is that the equivalence of the initial nonlinear system and its linear approximation is preserved only for certain processes, and if the system moves from one mode to another, it is necessary to change its linearized model, that is, it makes it impossible to take into account the change in the load on bearing unit.

The method of diagnosing roller bearings in labor [7] involves identifying and eliminating defects in bearings at the stage of harvesting them in the bearings of the assembly. The authors investigate the geometry and vibration signals generated by the acting bearings. The proposed method does not make it possible to evaluate the bearing life after a certain period of working time, as well as evaluate the efficiency of the lubricant used in it.

3. Methodology and results of research

Experimental studies were carried out on a laboratory installation (Fig. 1) for the diagnosis of roller bearings, using a sound-acoustic method using the software Gold Wave and Spectrogram. For research, the bearings of the front hub of the Mercedes Vito are selected.

Experiment on research of noise-acoustic indices of rolling bearings was carried out in several stages. The first stage was carried out as follows: the bearing of the wheel hub was lubricated with lubricant number 158, and installed on a laboratory installation (Fig. 1), that is, the case with a bearing was installed with a tension on the shaft and connected to the electric motor; the system of the levers changed the load on the shaft on which the post - The bearings are rolling, thus changing the load on the bearing itself.

With acoustic sensors and computer technology, audio files were recorded with the corresponding software; after switching off the plant, it was partially disassembled to replace the bearings with another lubricant. Next, the next launch of the installation with bearings was used in which the lubricant LITOL-24 and CIATIM-201 was used and the audio files were recorded. The load shift on the bearing also occurred with the use of counter-loads.

Several cycles of filing the bearings with different lubricants and different loadings on the bearing unit were carried out, and then analysis of these files was performed using Gold Wave and Spectrogram programs.

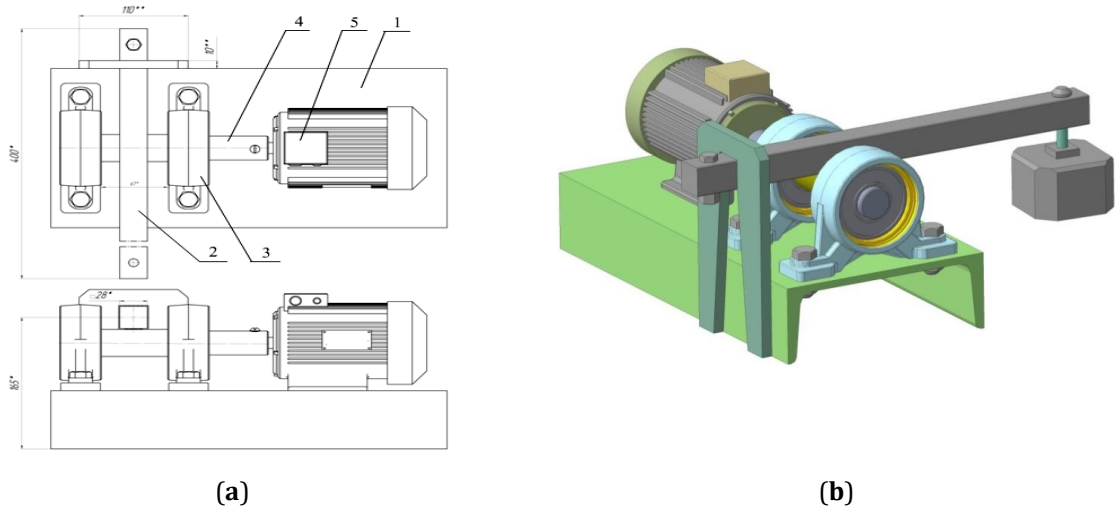
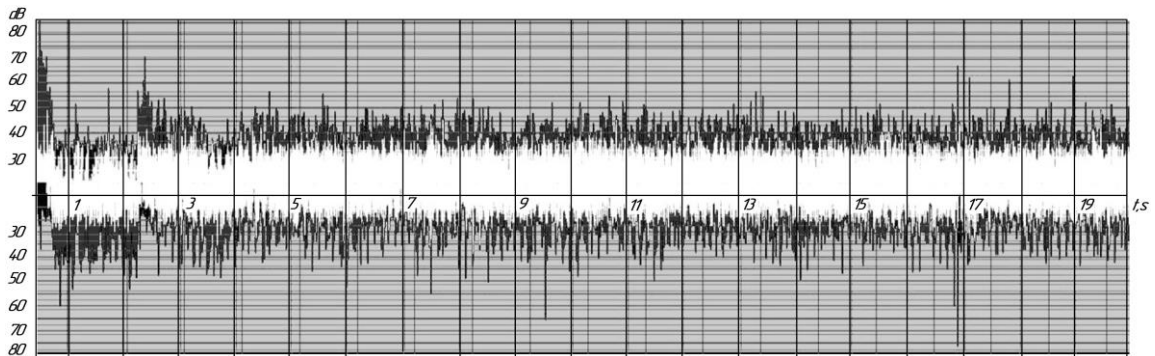

Figure 1. Installation for the diagnosis of roller bearings: (a) installation scheme; (b) three-dimensional model of installation; 1 – frame; 2 – loading mechanism; 3 – bearing; 4 – intermediate shaft; 5 – an electric motor.

The obtained data (spectrographs, diagrams and noise indicators) allow visually seeing and analyzing the wear condition of the bearing and the development of the defect in it, as well as the influence of the lubricant on the behavior of the noise-acoustic indicators.

An analysis of audio files (Fig. 2) made it possible to see how the behavior of the vibration acoustic indices of the bearing changes with the use of different lubricants.



(a)

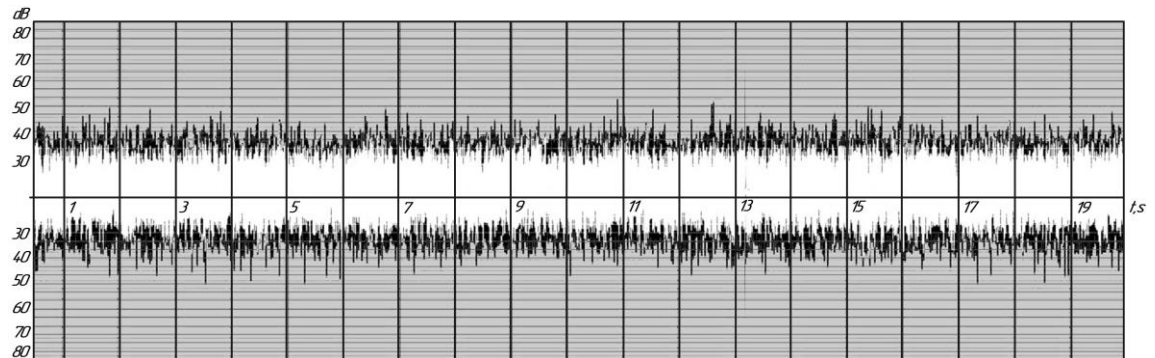

(b)

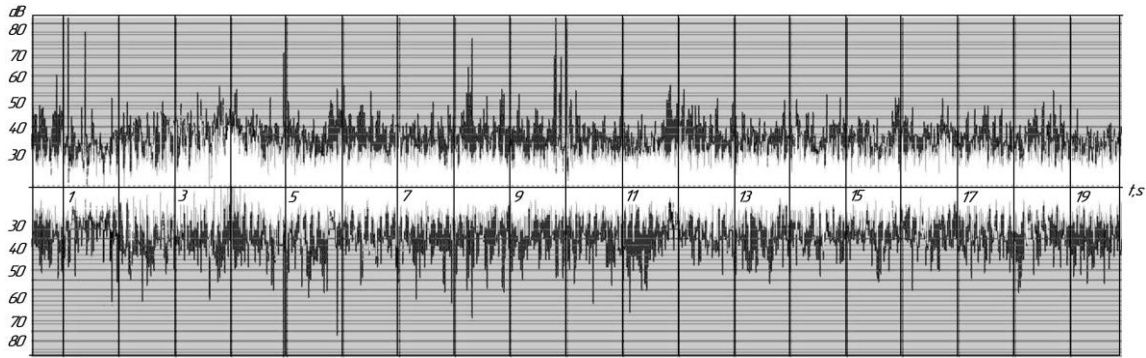

(c)

Figure 2. Diagrams of noise-acoustic indicators of bearings with the use of different lubricants: (a) lubricant №158; (b) lubricant LITOL-24; (c) lubricant CIATIM-201.

Diagrams allow you to clearly see the development of the defect and the overall picture of the state of the experimental under-spike and the dependence of the condition on the lubricant. The white color in the diagram shows the initial state of the test bearing, and the black is the limiting state.

The experiment used an electret microphone, microphone with the principle of action similar to the micro-phonons of the condenser type, which uses as a stationary plate of the condenser and the source of the post-voltage voltage plate from the electret.

Table 1 provides data on the magnitude of the noise band that was recorded during each cycle of the experiment with different lubricants.

Figure 3 shows the dependence of the magnitude of sound vibrations on the development of bearings and mastic materials.

Table 1. Results of measurement of noise level

Working hours, hours		100	200	300	400	500	600	800	1000
Number of revolutions of a bearing, 10 ⁶ rev		6	12	18	24	30	36	48	60
The size of the sound oscillations, dB	Lubricant №158	47.2	47.2	48.1	50.5	56.4	61.3	70.4	75.1
		47.5	47.3	48.3	50.4	56.6	61.7	70.5	75.2
		47.3	47.5	48.6	50.9	56.4	61.2	70.3	75.5
	LITOL-24	45.3	46.4	49.4	55.3	61.1	69.6	77.7	78.3
		45.5	46.1	49.7	55.7	61.2	69.2	77.4	78.6
		45.4	46.3	49.5	55.8	61.5	69.4	77.9	78.4
	CIATIM-201	42.3	50.4	56.2	64.6	68.3	74.3	78.4	80.3
		42.5	49.5	56.7	64.5	68.6	74.4	78.8	80.4
		42.6	49.8	56.3	64.2	68.4	74.5	78.4	80.5

In the second stage, the dependence of the radial beating of the bearings of the hub of the wheel on their overall performance was measured and the corresponding value of sound oscillations was measured. To determine the indications of radial beating of rolling bearings, a clock-type indicator mounted on a magnetic rack was used. The values of radial beating of bearings from their total output are given in Table 2.

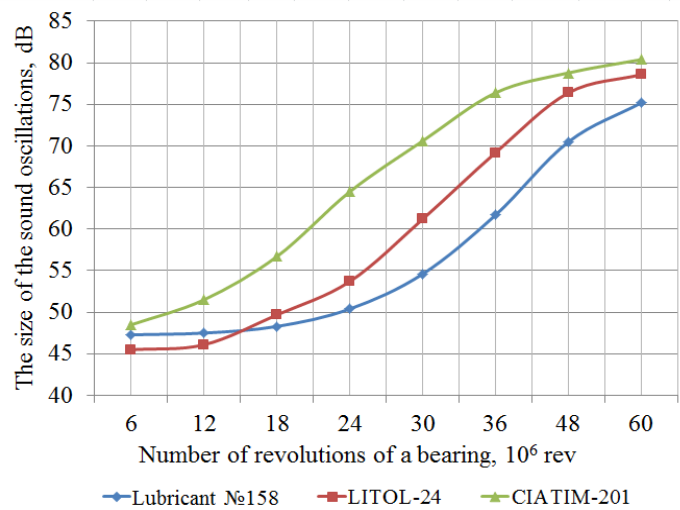

Figure 3. The dependence of the magnitude of sound vibrations on the development of bearings and lubricants

Table 2. Radial beating of bearings from their overall work

Number of revolutions of a bearing, 10 ⁶ rev	6	12	18	24	30	36	48	60
Radial beating of bearings, μm	9.5	11.2	12.1	15.4	18.2	25.4	32.6	41.3
The size of the sound oscillations, dB	42.3	49.4	56.2	64.6	68.3	74.3	78.4	85.3

Figure 4 shows the dependence of the radial beat of bearings on the value of sound vibrations. For the bearing of the hub of the wheel, which was investigated, the permissible values of radial beats were set, which make up for the lower limit of 10 μm , and for the upper one – 35 μm . Depending on the value of the sound vibrations, we determine the degree of bearing operation and its possible work life.

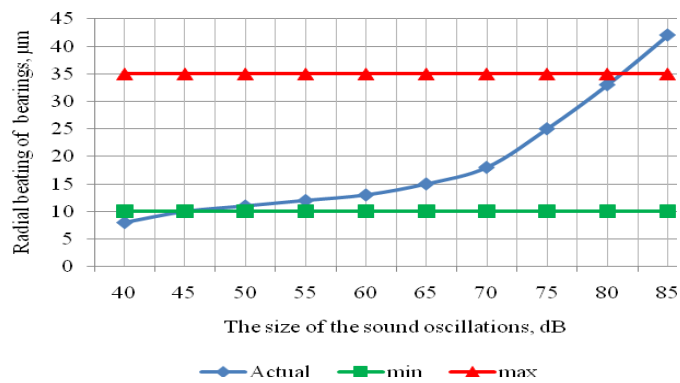

Figure 4. Dependence of radial beating of bearings on the value of sound oscillations

In the third stage a mathematical model was obtained for determining the dependence of acoustic parameters of bearings on their wear. This model takes into account the following parameters: the number of revolutions of the bearing; Load bearing perceived by the bearer; type of grease (number of penetration). Levels of variation above the above parameters are presented in Table 3.

Table 3. Levels of variation of factors

Factors	Marking factors	$x_i^* = -1.68$	$x_i = -1$	$x_i = 0$	$x_i = 1$	$x_i^* = 1.68$
Number of revolutions of a bearing $N, 10^6$ rev	x_1	5	15	30	45	55
Load bearing perceived by the bearer $G, 10^3$ H	x_2	4.5	5.5	7	8.5	9.5
Number of lubrication penetration ρ, mm^{-1}	x_3	235	250	270	290	305

Encoding of factors by means of transformation:

$$x_j = \frac{\tilde{x}_j - \tilde{x}_{j0}}{I_j}, \tag{1}$$

where \tilde{x}_j – coded value of the factor; \tilde{x}_j – the natural value of the factor; \tilde{x}_{j0} – the natural value of the main level; I_j – variation interval; j – factor number.

We show the matrix of the plan calculated according to the formula and the corresponding results of the experiment obtained (Table 4).

Table 4. The matrix of planning and research results

Experiment No.	x_0	x_1	x_2	x_3	x_1x_2	x_1x_3	x_2x_3	x^2_1	x^2_2	x^2_3	y	y_p	Deviation, %
1	1	1	1	1	1	1	1	1	1	1	78.2	77.3	1.15
2	1	1	1	-1	1	-1	-1	1	1	1	76.6	75.3	1.7
3	1	1	-1	1	-1	1	-1	1	1	1	65.8	66.5	-1.1
4	1	1	-1	-1	-1	-1	1	1	1	1	67.3	66.5	1.19
5	1	-1	1	1	-1	-1	1	1	1	1	52.4	53.3	-1.7
6	1	-1	1	-1	-1	1	-1	1	1	1	53.8	53.3	0.93
7	1	-1	-1	1	1	-1	-1	1	1	1	45.1	45.5	-0.9
8	1	-1	-1	-1	1	1	1	1	1	1	46.4	45.5	1.94
9	1	1.68	0	0	0	0	0	2.83	0	0	80.0	81.1	-1.4
10	1	-1.68	0	0	0	0	0	2.83	0	0	45.2	44.5	1.55
11	1	0	1.68	0	0	0	0	0	2.83	0	64.6	65.6	-1.5
12	1	0	-1.68	0	0	0	0	0	2.83	0	52.7	51.6	2.09
13	1	0	0	1.68	0	0	0	0	0	2.83	57.2	58.4	-2.1
14	1	0	0	-1.68	0	0	0	0	0	2.83	58.8	58.4	0.68
15	1	0	0	0	0	0	0	0	0	0	57.6	58.4	-1.4
16	1	0	0	0	0	0	0	0	0	0	57.1	58.4	-2.3
17	1	0	0	0	0	0	0	0	0	0	58.8	58.4	0.68
18	1	0	0	0	0	0	0	0	0	0	59.3	58.4	1.52
19	1	0	0	0	0	0	0	0	0	0	59.1	58.4	1.18
20	1	0	0	0	0	0	0	0	0	0	59.6	58.4	2.01

In this case, the mathematical model for a complete four factor experiment with the interaction of the mode has the form:

$$y_p = b_0 + b_1x_1 + b_2x_2 + b_3x_3 + b_{12}x_1x_2 + b_{13}x_1x_3 + b_{23}x_2x_3 + b_{11}x^2_1 + b_{22}x^2_2 + b_{33}x^2_3. \tag{2}$$

The coefficients of the model are calculated by the formula:

$$b_j = \frac{\sum_{i=1}^N x_{ji} \cdot y_i}{N}, \quad (3)$$

where $j = 0, 1, 2, \dots, k$; N – number of performed experiments ($N = 20$).

The coefficients of the model (2), which are calculated by the formula (3), make up:

$$b_0 = 58.5; b_1 = 10.9; b_2 = 4.1; b_3 = -0.83; b_{12} = 1.5; b_{13} = 0.25; b_{23} = 0.75; \\ b_{11} = 1.55; b_{22} = 0.14; b_{33} = -0.4.$$

The dispersion S_y^2 of reproducibility is determined by the results of research in the center of the plan. Dispersions that characterize the errors in determining the coefficients of the regression equation according to [8] for $k = 4$ are:

$$S^2\{b_0\} = 0.5833; S^2\{b_i\} = 0.2563; S^2\{b_{ii}\} = 0.1375; S^2\{b_{ij}\} = 0.0433.$$

When checking the coefficients by the criterion of the Investigator (with a 5% level of significance and a degree of free-body $f = 4$) found that all the coefficients are significant and exceptionally to the model (2).

Substituting the found coefficients into equation (2), we obtain the following relation:

$$y = 58.5 + 10.9 \cdot \tilde{x}_1 + 4.1 \cdot \tilde{x}_2 - 0.83 \cdot \tilde{x}_3 + 1.5 \cdot \tilde{x}_1 \cdot \tilde{x}_2 + 0.25 \cdot \tilde{x}_1 \cdot \tilde{x}_3 + 0.75 \cdot \tilde{x}_2 \cdot \tilde{x}_3 + \\ + 1.55 \cdot \tilde{x}_1^2 + 0.14 \cdot \tilde{x}_2^2 - 0.4 \cdot \tilde{x}_3^2. \quad (4)$$

The verification of the hypothesis of the adequacy of the model (4) according to Fisher's criterion at the 5% level of significance and the degrees of freedom of dispersion of adequacy $f_{ad} = N - k - (n_0 - 1) = 20 - 4 - (6 - 1) = 11$ and dispersion of reproducibility $f_y = n_0 - 1 = 6 - 1 = 5$ showed that the obtained models are adequate, since the calculated value of the criterion is less tabular $F_{cal} = 1,54 < F_T(0,05; 11; 5) = 3.2$.

In the equation (4), the variables $\tilde{x}_1, \tilde{x}_2, \tilde{x}_3$ are coded values:

$$\tilde{x}_1 = \frac{N - 30}{15} = 0.067 \cdot N - 2; \\ \tilde{x}_2 = \frac{G - 7}{1,5} = 0.67 \cdot G - 4,67; \\ \tilde{x}_3 = \frac{\rho - 270}{20} = 0.05 \cdot \rho - 13,5$$

where N – number of revolutions of a bearing, 10^6 rev; G – load bearing perceived by the bearer, 10^3 H; ρ – number of lubrication penetration, mm^{-1} .

For ease of computation, we convert the mathematical model (4) to a natural value:

$$\partial B = 33.15 - 0.381 \cdot N - 6.92 \cdot G + 0.3 \cdot \rho + 0.067 \cdot N \cdot G + 0.00084 \cdot N \cdot \rho + 0.025 \cdot G \cdot \rho + \\ + 0.007 \cdot N^2 + 0.063 \cdot G^2 - 0.001 \cdot \rho^2. \quad (6)$$

4. Conclusions

On the basis of the conducted experiment and the analysis of the data obtained, it can be concluded that the method of non-destructive noise-acoustic control of roller bearings with the use of various lubricants is used to obtain the most reliable data on the degree of wear of rolling bearings, their operation and to prevent the destruction of the entire site as a whole.

The considered noise-acoustic method allows us to develop recommendations for the application of certain types of lubricants in roller bearings.

The developed mathematical model allows, based on the acoustic parameters of the bearings, which were obtained during experimental studies, to determine the degree of wear and to predict the potential life of the bearing roller.

References

1. Korobochka, O.; Skornyakov, E.; Sasov, O. *Fundamentals of calculation, design and operation of technical equipment for motor transport*. DSTU: Dneprodzerzhinsk, 2007; 226p.
2. Kanevsky, I.; Sampikova, I. *Nondestructive methods of control*. DVSTU: Vladivostok, 2007; 243p.
3. Alian, H.; Konforty, S.; Ben-Simon, U.; Klein, R.; Tur, M.; Bortman, J. Bearing fault detection and fault size estimation using fiber-optic sensors. *Mechanical Systems and Signal Processing* 2019; 120(1), 392–407.
4. Martin-del-Campo, S.; Schnabel, S.; Sandin, F.; Marklund, P. Detection of particle contaminants in rolling element bearings with an supervised acoustic emission feature learning. *Tribology International* 2019; 63(1). 30–38.
5. Schmidt, S.; Heyns, P.; Gryllias, K. A discrepancy analysis methodology for rolling element bearing diagnostics under variable speed conditions. *Mechanical Systems and Signal Processing* 2019; 116, 40–61.
6. Piltan, F.; Kim, J. Bearing fault diagnosis using an extended variable structure feedback linearization observer. *Sensors Switzerland* 2018; 18(12), 43–59.
7. Jakubek, B., Jakubowicz, M., Smułek, W. Comparison of rolling bearings' diagnosing methods – Procedures of damage introduction. *Vibrations in Physical Systems* 2018; 29, 11–19.
8. Shklyar, V. N. *Planirovanie eksperimenta i obrabotka rezultatov*. TPU: Tomsk, 2010; 90 p.