

Purdue University Purdue e-Pubs

International Refrigeration and Air Conditioning
Conference

School of Mechanical Engineering

2018

Experimental evaluation of CO₂ ejector cooling system for supermarkets at tropical zones

Simarpreet Singh

Indian Institute of Technology Madras, India, spsinghbits@gmail.com

Armin Hafner

NTNU Trondheim, Norway, armin.hafner@ntnu.no

Krzysztof Banasiak

SINTEF Energy Research Trondheim, Norway, Krzysztof.Banasiak@sintef.no

Maiya M P

IIT Madras, India, mpmaiya@iitm.ac.in

Follow this and additional works at: <https://docs.lib.purdue.edu/iracc>

Singh, Simarpreet; Hafner, Armin; Banasiak, Krzysztof; and M P, Maiya, "Experimental evaluation of CO₂ ejector cooling system for supermarkets at tropical zones" (2018). *International Refrigeration and Air Conditioning Conference*. Paper 1934.
<https://docs.lib.purdue.edu/iracc/1934>

This document has been made available through Purdue e-Pubs, a service of the Purdue University Libraries. Please contact epubs@purdue.edu for additional information.

Complete proceedings may be acquired in print and on CD-ROM directly from the Ray W. Herrick Laboratories at <https://engineering.purdue.edu/Herrick/Events/orderlit.html>

Experimental evaluation of multi-ejector based CO₂ cooling system for supermarkets in tropical zones

Simarpreet Singh^(a), Armin Hafner^(b), Krzysztof Banasiak^(c), Prakash M. Maiya^(a), Petter Neksa^(b)

^(a)IIT Madras, 600036, India

^(b)NTNU Trondheim, 7034, Norway

^(c)SINTEF Energy Research Trondheim, 7034, Norway

ABSTRACT

Cooling system for supermarkets, now-a-days in developing countries like India, mainly uses man-made synthetic refrigerants/mixtures such as R134a, R404A and R410A (HFCs). These fluorinated refrigerants possess an outrageous impact on the environment/ambient due of their high GWP and ODP. The EU F-gas regulation is formulated recently and came into force in 2014 in order to limit the usage of synthetic refrigerants for various HVAC applications. Under this rule, it is likewise illegal to air out any such synthetic refrigerants to the atm during the system servicing or end-of-life decommissioning. Sudden phase down of HFCs forced the present scenario to identify a potential replacement of these synthetic refrigerants. The influence of the same is comparatively high for developing countries. In the present study, the performance of a multi-ejector based supermarket cooling system is experimentally evaluated using natural refrigerant carbon dioxide (CO₂). 33 kW cooling capacity of the system which is capable of maintaining three simultaneous different temperatures such as -29 °C for freezing, -6 °C for refrigeration and 7-11 °C for air-conditioning is examined at high ambient temperature context (up to 46 °C gascooler outlet temperature). The maximum COP of the supermarket cooling system appeared as 4.2. It is also observed that the maximum exergy efficiency of the system is 0.316 obtained corresponding to 3.2 PIR of the system.

Keywords: Ejector; CO₂; Supermarket; HFCs; PIR.

1. INTRODUCTION

Revival of interest in the natural working fluid such as carbon dioxide (CO₂) for the supermarket cooling application in recent years is triggered by environmental concern of high GWP of the synthetic refrigerants being used in HVAC systems. It was observed that researchers found no logic behind further evolving a new class of synthetic refrigerants. Nevertheless, increasing demand for thermal comfort and living standards led to a rapid growth in the use of cooling and heating systems. Natural refrigerant such as CO₂ with ejector based technology appeared as a viable solution to fulfill the increasing demand of air conditioning, domestic water heating and residential space heating demand (Milazzo and Mazzelli, 2017). Ejector being considered as the most reliable solution for progressive improvement in the overall performance of the CO₂ cooling system with limited maintenance and low operational cost (Banasiak et al., 2012). Improving the overall efficiency, supermarket application is a matter of concern now-a-days for developing countries like India by replacing synthetic refrigerants with natural (Singh and Dasgupta, 2017).

Various studies were reported regarding the use of CO₂ system for various applications especially supermarkets. Various studies have reported, comparing the performance of conventional refrigerants and CO₂ refrigerant for supermarkets and improvement in performance (Giroto et al., 2004), (Cecchinato et al., 2010), (Sharma et al., 2014). A supermarket application based software such as “SuperSim” was also developed to evaluate the performance of the system for various ambient conditions (Ge and Tassou, 2011a, 2011b). Effect of cascading with CO₂ refrigerant with other combination of refrigerants was also analyzed (Da Silva et al., 2012). A study was reported in order to fulfil simultaneous heating and cooling demand with a CO₂ system (Sawalha, 2013). Five supermarkets installed between the year 2007 to 2010 in Sweden were studied. Using the field measurements, it was observed that the CO₂ system consumed 11% less energy as compared to the conventional cooling systems. It was concluded that the CO₂ system is more energy efficient solution for supermarkets for a colder climate (Sawalha et al., 2017).

2. SUPERMARKET DESCRIPTION

A fully instrumented CO₂ test facility of 33 kW cooling capacity is designed for supermarket application to maintain three different temperatures such as for freezing (-29°C), refrigeration (-6°C) and air conditioning (7-11°C). The test facility is also equipped with a heat recovery system with a water - glycol solution to maintain a constant heat load demand (Figure 1).

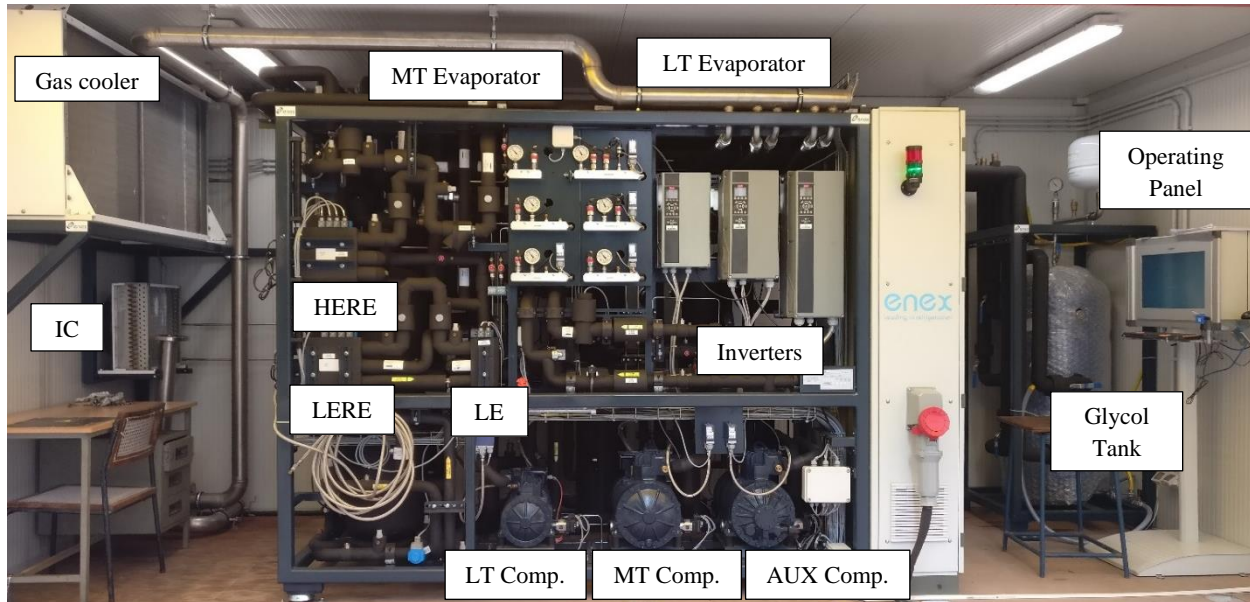

Figure 1: Supermarket facility.

Load of medium temperature (MT) and low temperature (LT) evaporators on the water side are controlled by manually controlled EEV installed before the suction port to the evaporators. However, AC evaporator temperature is controlled by receiver pressure. Two glycol loop circuits are arranged with different glycol concentrations; 42% for MT & AC load and 56% for LT load. Shell-tube design evaporator and air-cooled gascooler with tube-fin design is installed in the supermarket facility. Three compressors are arranged, LT & MT compressors and an additional AUX compressor is installed to handle high amounts of flash gas from the receiver which also enables the parallel compression operation. Three separate inverters are installed to control the compressor motor frequency automatically.

Two ejectors are installed with low ejection ratio ejector (LERE), high ejection ratio ejector (HERE). One liquid suction accumulator is also installed in order to provide an excess feed to over feed the evaporators throughout the year. Temperature sensors, pressure sensors and energy meters are installed at various locations to evaluate the performance of the system and examine the various parameter variations. The system facilitates both manual and automatic optimization of gascooler pressure with gascooler outlet temperature. The facility also has a manual operated controller to change the air speed of the gascooler fans.

For safety purpose, the test rig has five high pressure safety valves for various system pressure levels in the test facility which further connect with a single overhead discharge line. Two CO₂ refrigerant charging ports and two glycol charging ports are arranged at the facility. Operating panel is used to feed the required CO₂ parameters for the experimental operation and glycol side load is maintained using manual controller. Manually operated ball valves are installed to configure internal heat exchanger (IHx) and sub cooler in the system for the required operation. Number of air purges are available in glycol loop line to extract the air bubbles from the system. The test - rig also can work seven different modes of operation and it is designed in order to evaluate various possible configurations for supermarket application at high ambient temperature (up to 46°C).

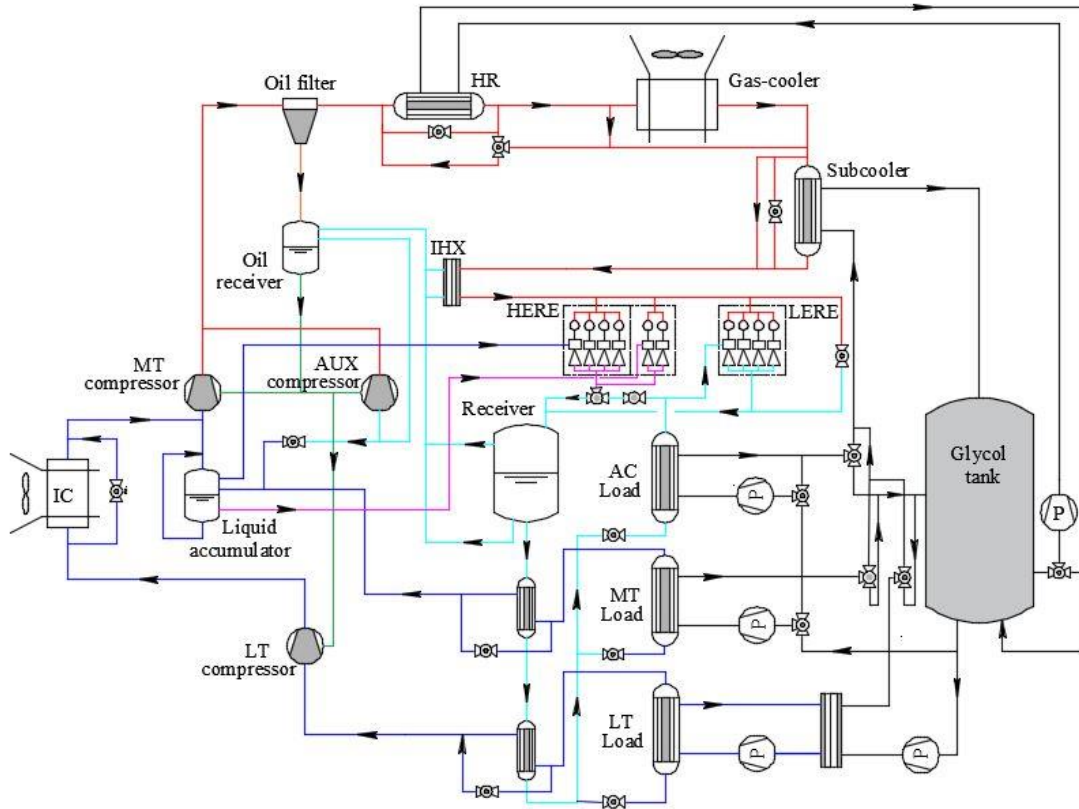

Figure 2: Schematic of the CO₂ supermarket facility.

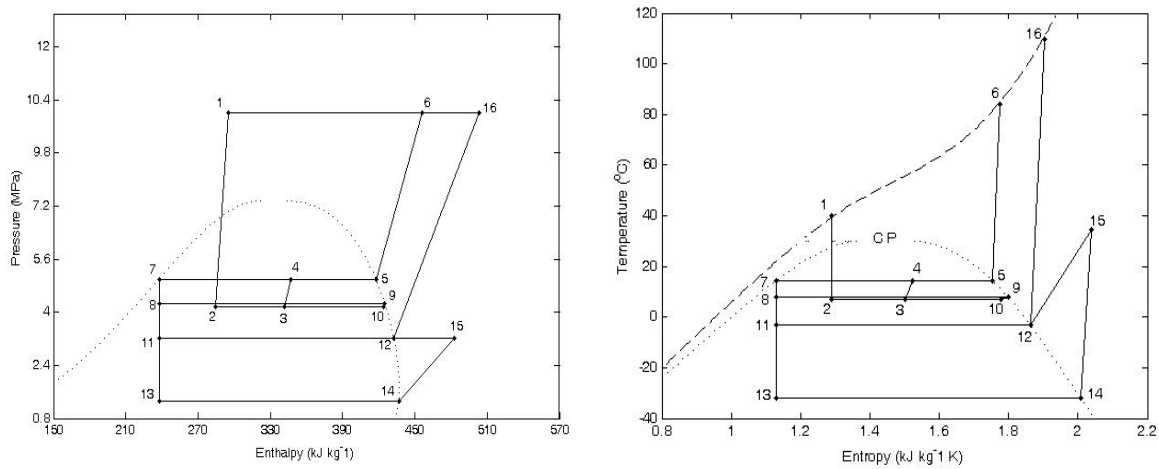

Figure 3: P-h and T-s plot of the supermarket operational mode.

Figure (2) shows the detailed schematic of the CO₂ supermarket facility projecting various components installed in the test system. Among the seven different available modes, Figure (3) shows the typical supermarket operational mode of the test facility for the present study along with its corresponding states during the operation. Description of various states obtained during the operation is tabulated in Table (1).

Table 1: Description of various state of supermarket operation.

<i>State</i>	<i>Description</i>	<i>State</i>	<i>Description</i>
1	Gas cooler exit	9	AC evaporator discharge
2	Ejector primary nozzle suction	10	Ejector secondary nozzle suction
3	Ejector mixing chamber	11	MT evaporator suction
4	Ejector discharge	12	MT evaporator discharge
5	Receiver discharge (vapor side)	13	LT evaporator suction
6	AUX compressor discharge	14	LT evaporator discharge
7	Receiver discharge (liquid side)	15	LT compressor discharge
8	AC evaporator suction	16	MT compressor discharge

3. PERFORMANCE EVALUATION

The performance of the supermarket test facility is evaluated for various gascooler outlet temperature after achieving the steady state which needs ~45 minutes. Hourly based data extracted for a required single gascooler outlet temperature and averaged value of the various parameters is used for the calculation. The range/value of various parameters used during performance evaluation is tabulated in Table (2).

Table 2: Parameters used for performance evaluation.

<i>Operating parameter</i>	<i>Units</i>	<i>Value/Range</i>
Gascooler outlet temperature	°C	36, 41, 46
Gascooler outlet pressure	bar	80 to 120
AC evaporator temperature	°C	7 to 11
MT evaporator temperature	°C	-6
LT evaporator temperature	°C	-29
Receiver pressure	bar	44

Performance of the multi-ejector based CO₂ cooling system for supermarket application at high ambient temperature is computed using Eqs. (1-7).

Evaporator load of the system is computed using Eq. (1).

$$\dot{Q}_{evap} = \dot{v} \rho * c_p * (T_{evap_out} - T_{evap_in}) \quad (1)$$

The heat recovery from the system is computed using Eq. (2).

$$\dot{Q}_{hr} = \dot{v} \rho * c_p * (T_{hr_out} - T_{hr_in}) \quad (2)$$

COP of the system is computing using Eq. (3).

$$COP = \frac{Q_{evap} + Q_{hr}}{W_{Dcomp.}} \quad (3)$$

Ejector entrainment ratio (μ) of the system is computed using Eq. (4).

$$\mu = \frac{m_{evap}}{m_{gc}} \quad (4)$$

Second law efficiency is computer using Eq. (5).

$$\eta_{ex} = \frac{B_{MT} + B_{LT} + B_{AC} + B_{HR}}{P_{MT, + PLT, + PAUX}} \quad (5)$$

where, for heat recovery (HR):

$$B_{ex,i} = \dot{Q}_{ex,i} * (1 - \frac{T_{amb}}{T_{ut,i}})$$

and for refrigeration (AC, MT & LT)

$$B_{ex,i} = \dot{Q}_{ex,i} * (\frac{T_{amb}}{T_{ut,i}} - 1)$$

Heat transfer is computed using Eq. (6).

$$\dot{Q}_{ex,j} = \rho_j * \dot{V}_j * \Delta h_j \quad (6)$$

Power Input Ratio (PIR) of the system is compute using Eq. (7).

$$PIR = \frac{P_{MT,act} + P_{AC,act} + P_{LT,act} + P_{H,act} + P_{SAW,act}}{P_{MT,Carnot} + P_{AC,Carnot} + P_{LT,Carnot} + P_{H,Carnot} + P_{SAW,Carnot}} = \frac{\sum_i P_{i,act}}{\sum_i P_{i,Carnot}} \quad (7)$$

$$\text{where, } P_{i,c} = \frac{\dot{Q}_{ex}}{T_{ut,i}} * (T_{amb} - T_{ut,i})$$

4. RESULTS AND DISCUSSION

In order to achieve the main objective of the present study, the performance of the supermarket is evaluated at high ambient condition (36 °C, 41 °C and 46 °C). The average mass flow rate of water-glycol solution for each evaporators and heat recovery of the test facility at various gascooler temperature are tabulated in Table (3).

Table 3: Mass flow rate of water-glycol solution.

Heat exchanger		Gascooler Outlet Temperature		
		36 °C	41 °C	46 °C
Evaporators	MT (kg/s)	0.146	0.038	0.041
	LT (kg/s)	0.300	0.300	0.186
	AC (kg/s)	0.585	0.584	0.495
Heat Recovery	HR (kg/s)	1.096	1.066	0.985

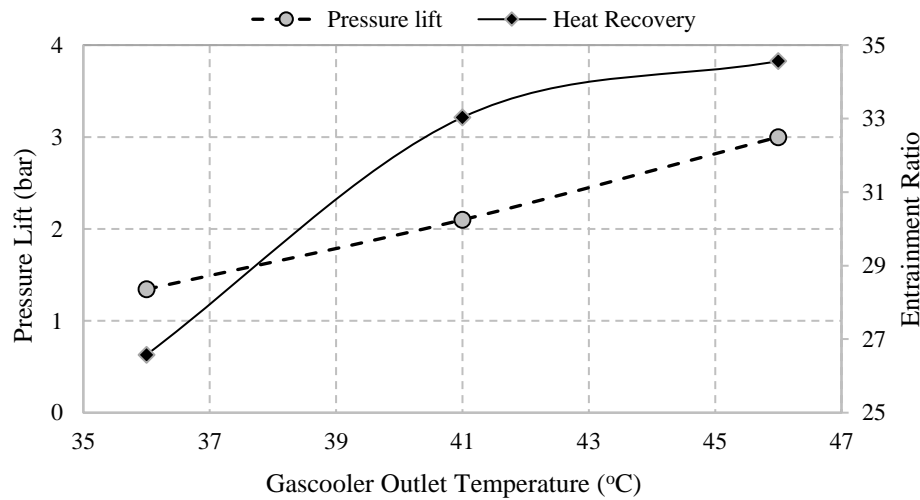

Figure 3: Pressure lift provide by the two-phase ejector with gascooler outlet temperature.

The pressure lift provided by the two-phase ejector and heat recovery by the system as the function of gascooler outlet temperature is shown in Figure (3). Heat recovery through the system is also projected. It is observed that as the gascooler pressure corresponding to gascooler outlet temperature increases the pressure lift increases. Increase in vapor generated in the receiver with increasing gascooler temperature, further results in an increased mass flow rate through the motive nozzle of the two-phase ejector. Also, with increasing gascooler pressure the motive pressure of the two-phase ejector increases, which further enhance the momentum in ejector. The combination of these two phenomena increases the pressure life generation by the two-phase ejector with increase in gascooler outlet temperature. It is observed that maximum 34.5 kW heat can be recovered at a high gascooler exit temperature (46°C).

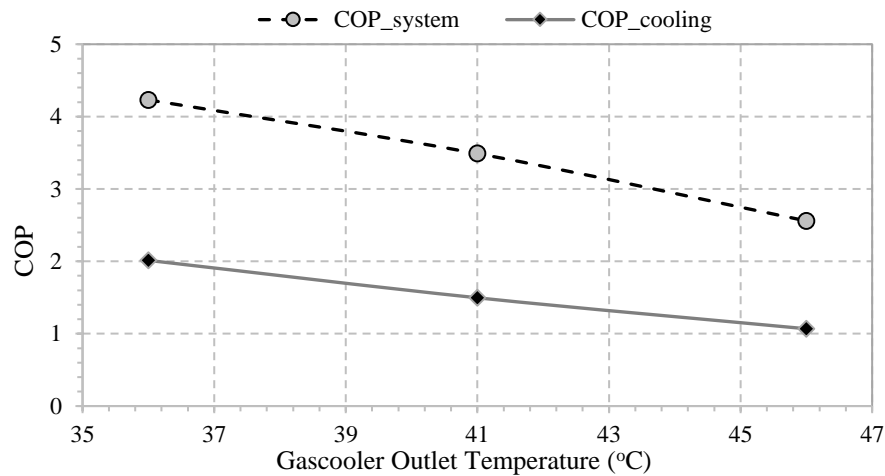

Figure 4: COP with gascooler outlet temperature.

Figure (4) shows the COP (system and cooling) of the supermarket test facility at various gascooler outlet temperature. System COP projected is high as compare to cooling COP as it also incorporated the effect of heat recovery from the CO₂ supermarket facility. Traditional trend is observed, as the gascooler outlet temperature increase, COP decreases. The maximum CO₂ system and cooling COP are 4.2 and 2 respectively.

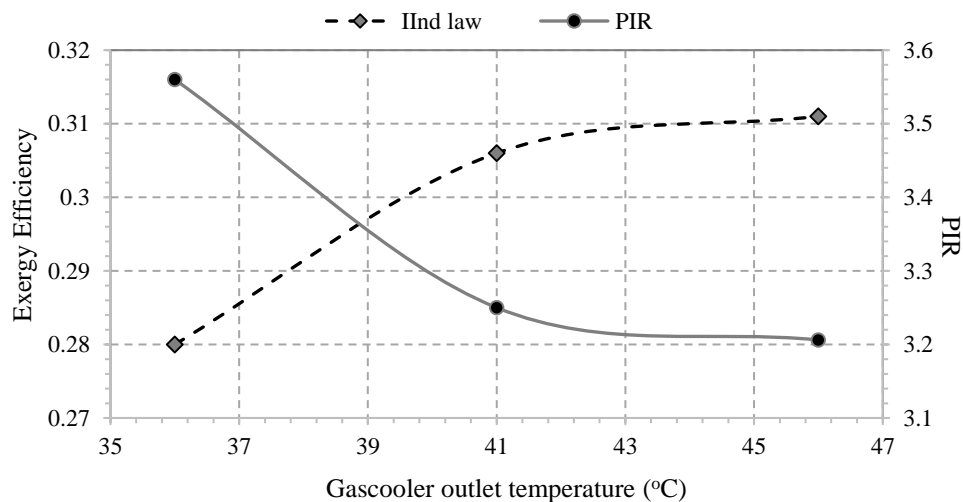

Figure 5: Exergy efficiency and PIR of the system with gascooler outlet temperature.

Figure (5) shows the exergy efficiency and Power Input Ratio (PIR) of the CO₂ system at various gascooler outlet temperature. Second law is used to evaluate the performance of the system because it incorporates the total

exergy losses from the various system components. PIR reflects the total consumption by the system which incorporates all energy consuming components. However, as the PIR of the system decreases due to reduction in energy consumption by the system, the Exergy efficiency increases. Maximum exergy efficiency of 0.315 of the system is obtained corresponding to 3.2 PIR of the system at 46 °C gascooler outlet temperature.

5. CONCLUSIONS

An experimental study carried out for a supermarket facility in order to evaluate the performance of multi-ejector based CO₂ cooling system at high climatic context (36 to 46°C). The following conclusions are drawn from the present study.

- A pressure lift of 3 bar is obtained at 46 °C by the two-phase ejector.
- Maximum system COP and cooling COP are obtained as 4.2 and 2 respectively at 36 °C.
- It is observed that maximum 34 kW heat can be recovered at a high gascooler outlet temperature (46 °C).
- The maximum Exergy efficiency of the system is 0.315 obtained corresponding to 3.2 PIR of the system at 46 °C gascooler outlet temperature.

6. FUTURE PROSPECTIVE

A comparative analysis will be carried out with the results obtained from the present experimental study and the synthetic refrigeration system with the support of field data in order to project the actual scenario of both technologies.

Acknowledgements

The work presented is part of an ongoing Indo-Norwegian project funded by the Ministry of Foreign Affairs, Government of Norway coordinated by SINTEF, Norway. The Indian authors acknowledge the additional support received from the Department of Science and Technology (DST) under project: PDF/2017/000083.

Acronyms

HR	Heat recovery
P	Power consumption
PIR	Power Input Ratio
WD	Work done

Greek Symbols

ρ	Density
η	Efficiency
μ	Entrainment ratio

Nomenclature

c_p	Specific heat	(W kg ⁻¹ K ⁻¹)
h	Enthalpy	(kJ kg ⁻¹)
\dot{m}	Mass flow rate	(kg s ⁻¹)
\dot{Q}	Heat transfer rate (kW)	
T	Temperature	(°C)
$\dot{v}ol, \dot{V}$	Volume flow rate	(m ³ s ⁻¹)
W	Work	(W)

Subscript and Superscript

<i>amb</i>	Ambient
<i>act</i>	Actual
<i>comp</i>	Compressor

<i>evap</i>	Evaporator
<i>ex</i>	Exergy
<i>gc</i>	Gas cooler
<i>hr</i>	Heat recovery
<i>in</i>	Inlet
<i>out</i>	Outlet
<i>ut</i>	heat source

References

- Banasiak, K., Hafner, A., Andresen, T., 2012. Experimental and numerical investigation of the influence of the two-phase ejector geometry on the performance of the R744 heat pump. *Int. J. Refrig.* 35, 1617–1625. <https://doi.org/10.1016/j.ijrefrig.2012.04.012>
- Cecchinato, L., Corradi, M., Minetto, S., 2010. Energy performance of supermarket refrigeration and air conditioning integrated systems working with natural refrigerants. *Appl. Therm. Eng.* 48, 378–391. <https://doi.org/10.1016/j.applthermaleng.2012.04.049>
- Da Silva, A., Bandarra Filho, E.P., Antunes, A.H.P., 2012. Comparison of a R744 cascade refrigeration system with R404A and R22 conventional systems for supermarkets. *Appl. Therm. Eng.* 41, 30–35. <https://doi.org/10.1016/j.applthermaleng.2011.12.019>
- Ge, Y.T., Tassou, S.A., 2011a. Performance evaluation and optimal design of supermarket refrigeration systems with supermarket model “superSim”. Part II: Model applications. *Int. J. Refrig.* 34, 540–549. <https://doi.org/10.1016/j.ijrefrig.2010.11.004>
- Ge, Y.T., Tassou, S.A., 2011b. Performance evaluation and optimal design of supermarket refrigeration systems with supermarket model “superSim”, Part I: Model description and validation. *Int. J. Refrig.* 34, 527–539. <https://doi.org/10.1016/j.ijrefrig.2010.11.010>
- Giroto, S., Minetto, S., Neksa, P., 2004. Commercial refrigeration system using CO₂ as the refrigerant. *Int. J. Refrig.* 27, 717–723. <https://doi.org/10.1016/j.ijrefrig.2004.07.004>
- Milazzo, A., Mazzelli, F., 2017. Future perspectives in ejector refrigeration. *Appl. Therm. Eng.* 121, 344–350. <https://doi.org/10.1016/j.applthermaleng.2017.04.088>
- Sawalha, S., 2013. Investigation of heat recovery in CO₂ trans-critical solution for supermarket refrigeration. *Int. J. Refrig.* 36, 145–156. <https://doi.org/10.1016/j.ijrefrig.2012.10.020>
- Sawalha, S., Piscopiello, S., Karampour, M., Manickam, L., Rogstam, J., 2017. Field measurements of supermarket refrigeration systems. Part II: Analysis of HFC refrigeration systems and comparison to CO₂ trans-critical. *Appl. Therm. Eng.* 111, 170–182. <https://doi.org/10.1016/j.applthermaleng.2016.09.073>
- Sharma, V., Fricke, B., Bansal, P., 2014. Comparative analysis of various CO₂ configurations in supermarket refrigeration systems. *Int. J. Refrig.* 46, 86–99. <https://doi.org/10.1016/j.ijrefrig.2014.07.001>
- Singh, S., Dasgupta, M.S., 2017. CO₂ heat pump for waste heat recovery and utilization in dairy industry with ammonia based refrigeration. *Int. J. Refrig.* 78, 108–120. <https://doi.org/10.1016/j.ijrefrig.2017.03.009>