

# Learning in Context with Horizontally & Vertically Integrated Curriculum

R. Athinarayanan, J. Garcia, B. Newell, X.  
Diao, J. Ostenek, G. Richards, H. Zhang, and  
R. Sundararajan

Professor, [rathinar@purdue.edu](mailto:rathinar@purdue.edu)

2018 PolySummit-UTEC-Lima-Peru

June 4-6 2018

**PURDUE**  
POLYTECHNIC



# MOTIVATION FOR A SMART LEARNING FACTORY

To present a methodology for reducing course silos by deliberately fusing the interconnection between courses and use the SMART Learning Factory (SMLF) as a platform to unify projects at Purdue Polytechnic Institute, a horizontally and vertically integrated curriculum is investigated.

The SMLF is a new concept being pursued to support

- learn-by-doing,
- project-based learning,
- learning in context, and
- interdisciplinary/multidisciplinary learning approaches.

Functionally, the SMLF is a replica of an actual factory designed to offer students the experience of a real production environment at an industry-relevant scale.

# MOTIVATION FOR A SMART LEARNING FACTORY

Using this SMLF platform, activities are developed to deliberately connect learning across multiple courses, whether they are within the same semester, same year, or between different years.

This will involve integration of activities in

design,  
manufacturing systems,  
production processes,  
production management,  
automation,  
energy,  
information technology,  
teamwork,  
cooperation,  
communications, and  
project management.

Students from freshman through senior year will be able to understand the interconnection of content between different courses and gain a holistic perspective of the interdependent structures of a manufacturing system.

# MOTIVATION FOR A SMART LEARNING FACTORY

#D2778

## INDUSTRY 4.0

Horizontal and Vertical Integration

### HORIZONTAL INTEGRATION:

- Networking between manufacturing sites
- Customer involvement in the process
- Exchanging information throughout the value chain
- Intelligent system communication in demand, production and logistics

### VERTICAL INTEGRATION:

- Networking within the company from the manufacturing level to the field level
- IT systems communicate at all levels

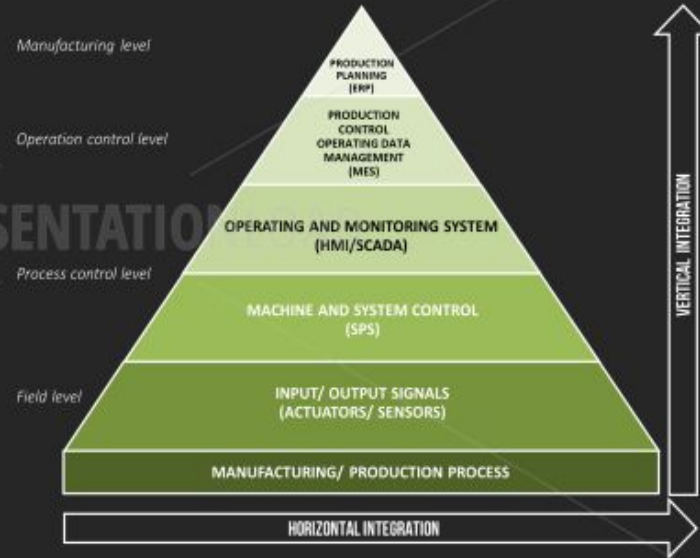

# MOTIVATION FOR A SMART LEARNING FACTORY

*Industry 4.0 applications enabled by the IoT are expected to create a new surge of factory productivity, creating value up to USD 3.7 trillion per year in 2025*

Report by McKinsey Global Institute

# SMART FACTORY & SMART MANUFACTURING

- **Goal** – To achieve optimal operational capabilities across the manufacturing value chain by leveraging the sensor networks and the IoT platform connecting activities at the Machine-, Factory-, and Enterprise-levels.
- **Enterprise-Level CPS** – “**Horizontally Integrated**” Cyber Physical Systems (CPS) connecting Machine-, Factory- (MES & FEMS), and Enterprise-level operations (ERP) that are managed and optimized using a network of intelligent systems and IoT devices that collect and share data over the Cloud & Edge
- **Factory-Level CPS** – “**Vertically Integrated**” Factory-level operations such as product development, production planning, process control, quality control, facility management and logistics management managed and optimized using a network of intelligent systems and IoT devices that collect and share data over the Cloud & Edge.
- **Machine-Level CPS** - Management of Machine-level operations achieved through the automation of critical machine functions using digital twin and machine learning.

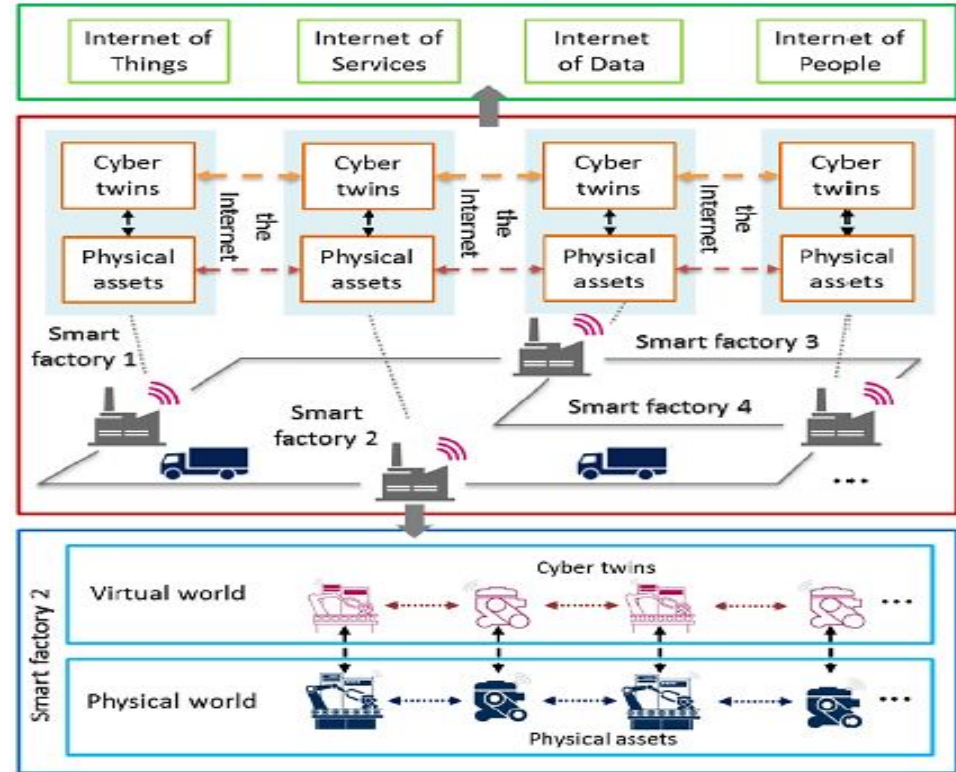

# MOTIVATION FOR A LEARNING FACTORY

- The learning factory is a replica of an industrial production system where formal and informal learning takes place.
- Learning Factory is a carefully designed competency development platform with the following characteristics:
  - *allows learning in a realistic manufacturing environment*
  - *brings learning closer to industrial practice*
  - *supports learn by doing, project-based learning, and interdisciplinary learning approaches*
  - *improves student problem solving, creativity, and systems thinking capabilities.*
  - *a state-of-the-art highly networked and interconnected, real-time, adaptive, and decentralized cyber-physical manufacturing and production system.*

# LEARNING FACTORY - HISTORY

## History

- *In 1994, NSF awarded a consortium led by Penn State to develop a “learning factory” for interdisciplinary hands-on senior engineering design projects with strong links and interactions with industry.*
- *In 1995 a college wide infrastructure at Penn State was established equipped with machines, materials, and tools to support hundreds of industry-sponsored design projects.*
- *In 2006, Penn State program was recognized nationally and received the National Academy of Engineering Gordon Prize for Innovation in Engineering Education.*
- *In 2011, the Initiative on European Learning Factories was established and the 1<sup>st</sup> Conference on Learning Factories was held.*
- *In 2014, the International Academy for Production Engineering (CIRP) established a Collaborative Working Group on Learning Factories to work with universities and support this movement.*
- *Early models of Learning Factory emphasized hands-on experience gained by applying knowledge at the culmination of engineering education to solve real problems in industry and design/redesign products to satisfy unidentified needs.*
- *Newer models emphasize a complete and integrative product value stream modules from raw materials to the shipped products in the bachelor degree curriculum.*
- *Newer models have increased activities in research, training, service, and Industry collaboration.*





Award Abstract #0234478

## Vertical and Horizontal Integration of Manufacturing Courses in Engineering Curricula

<b>NSF Org:</b>	<a href="#">EEC</a> <a href="#">Div Of Engineering Education and Centers</a>
<b>Initial Amendment Date:</b>	February 7, 2003
<b>Latest Amendment Date:</b>	October 11, 2006
<b>Award Number:</b>	0234478
<b>Award Instrument:</b>	Standard Grant
<b>Program Manager:</b>	Sue Kemnitzer EEC Div Of Engineering Education and Centers ENG Directorate For Engineering
<b>Start Date:</b>	March 1, 2003
<b>End Date:</b>	August 31, 2007 (Estimated)
<b>Awarded Amount to Date:</b>	\$491,064.00
<b>Investigator(s):</b>	Lucy King lking@kettering.edu (Principal Investigator) Jacqueline El-Sayed (Co-Principal Investigator) Tony Lin (Co-Principal Investigator) Gwan-Ywan Lai (Former Co-Principal Investigator)
<b>Sponsor:</b>	Kettering University 1700 University Ave Flint, MI 48504-6214 (810)762-9677
<b>NSF Program(s):</b>	ENGINEERING EDUCATION
<b>Program Reference Code(s):</b>	0000, 110E, 7218, 9177, OTHR, SMET
<b>Program Element Code(s):</b>	1340

### ABSTRACT

Vertical and Horizontal Integration of Manufacturing Courses in Engineering Curricula

The goal is to define a unique, novel model with strategies, processes and teaching tools and materials, to vertically integrate manufacturing courses and horizontally integrate mechanical engineering and industrial engineering courses, and to extend this model to other universities nationally.



# Vertical And Horizontal Integration Of Laboratory Curricula And Course Projects Across The Electronic Engineering Technology Program

Wei Zhan, Texas A&M University, USA  
Ana Goulart, Texas A&M University, USA  
Joseph A. Morgan, Texas A&M University, USA  
Jay R. Porter, Texas A&M University, USA

## ABSTRACT

*This paper discusses the details of the curricular development effort with a focus on the vertical and horizontal integration of laboratory curricula and course projects within the Electronic Engineering Technology (EET) program at Texas A&M University. Both software and hardware aspects are addressed. A common set of software tools are introduced to the sophomore students in the EET curriculum; these tools are then used in several junior and senior level courses. Through early and repeated exposure to these tools, students learn to use them more effectively to solve various engineering problems in laboratory and course projects. A DC permanent magnetic motor is identified as one of the common hardware platforms for multiple course projects. By using a common platform for different course projects, the students can spend much less time preparing for the course projects. With each course adding different features to the common platform, the learning experience in several courses becomes seamlessly integrated. Surveys were conducted to show that the curriculum development effort improved the efficiency of student learning and enhanced the students' educational experience.*

**Keywords:** Curriculum Integration; DC Motor; Modeling and Simulation; Engineering Education

## INTRODUCTION



One of the emphases for undergraduate Engineering Technology (ET) education is hands-on experiences gained through laboratory classes and course projects. Almost every junior and senior level course in the Electronics Engineering Technology (EET) and Telecommunications Engineering Technology



# Vertical Integration

**Course and project activities from one semester are deliberately linked and connected sequentially, either in the same year or a different year.**

**Each course and its corresponding project activities are integrated as part of a larger project that spans all four years and the four stages of the SLF.**

**The vertical progression will sequentially build depth and complexity to enable students to gradually build interdisciplinary understanding of the various systems, and their interrelated and interdependent parts.**

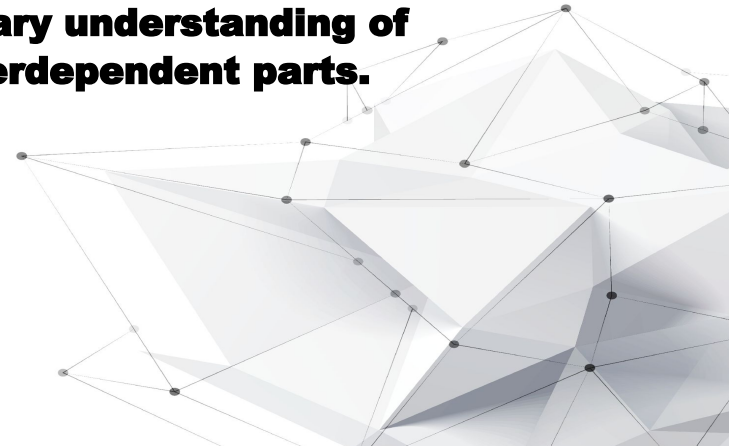

# Horizontal Integration

**We will deliberately fuse the learning activities of multiple courses offered during the same semester.**

**These courses will all share the same SLF project and activities will focus only on one of the 4-stages of the SLF.**

**Students will work simultaneously and collaboratively in an interdisciplinary team from different courses.**

**Process will enable students to engage in peer mentoring and learn from the experience and expertise of other students, develop communication and interpersonal skills, and learn how to jointly develop strategies to solve problems encountered in the SLF.**

**This horizontal integration will help students to fluidly move from one course to another with continuity, and carry with them the knowledge and skills they've obtained from their engagement with the horizontally integrated courses.**

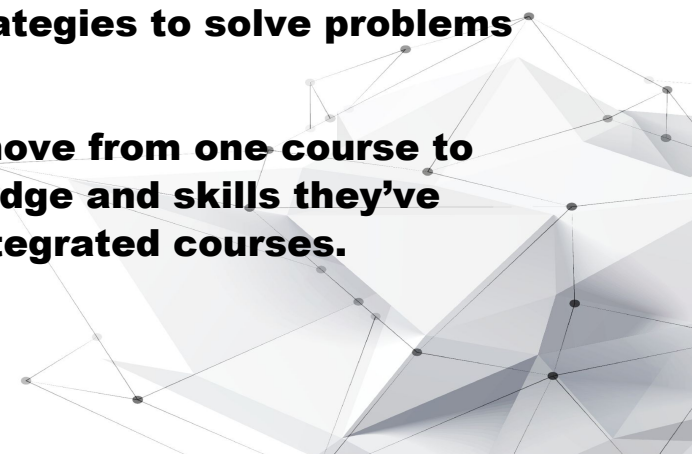

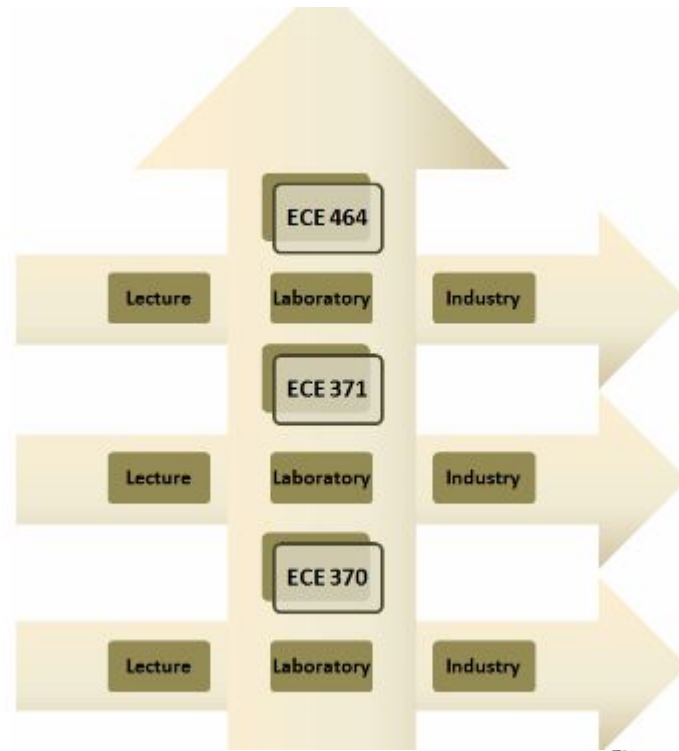

**An Example of Vertical & Horizontal Curriculum Integration**



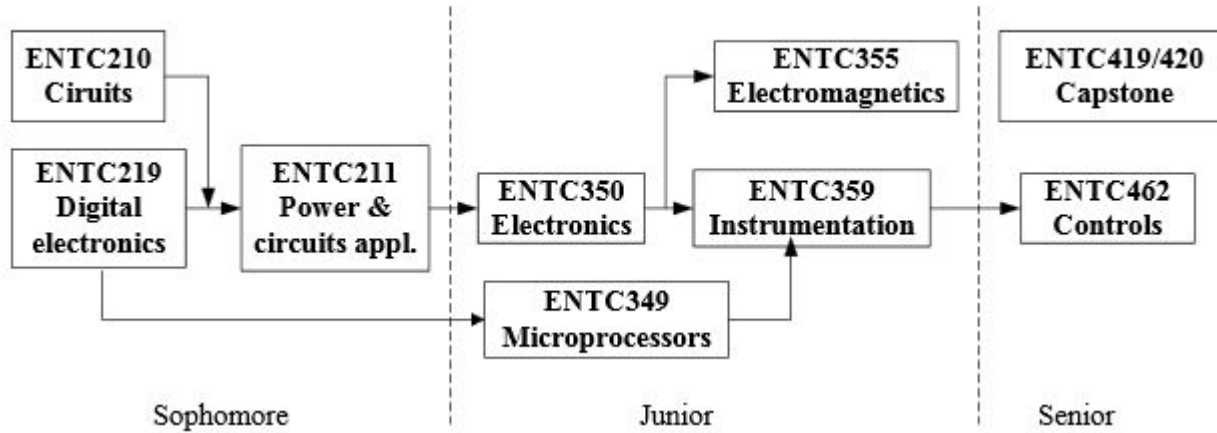

## Curriculum Flowchart for Relevant Courses



# SMART LEARNING FACTORY – ADVANCED CAPABILITIES

## Advanced Capabilities:

- A Cloud based IoT Platform
  - *For computing/storage of machine-, factory-, and enterprise-level data*
- Big Data/Manufacturing Analytics:
  - *Monitor/Analysis of structured and unstructured data and building operational intelligence*
- Asset Connectivity & Management (ERP/MES/FEMS)
  - *Connectivity between machine-, factory-, and enterprise-level assets*
- Visualization, VR, and AR using data from the Cloud/Edge
- IoT Connected Logistics
- IoT Energy Efficiency & Management
- Cyber-Physical Production Systems
- Collaborative Robots (COBOT) & Autonomous Robot
- Additive Manufacturing

# SMART LEARNING FACTORY - GOAL

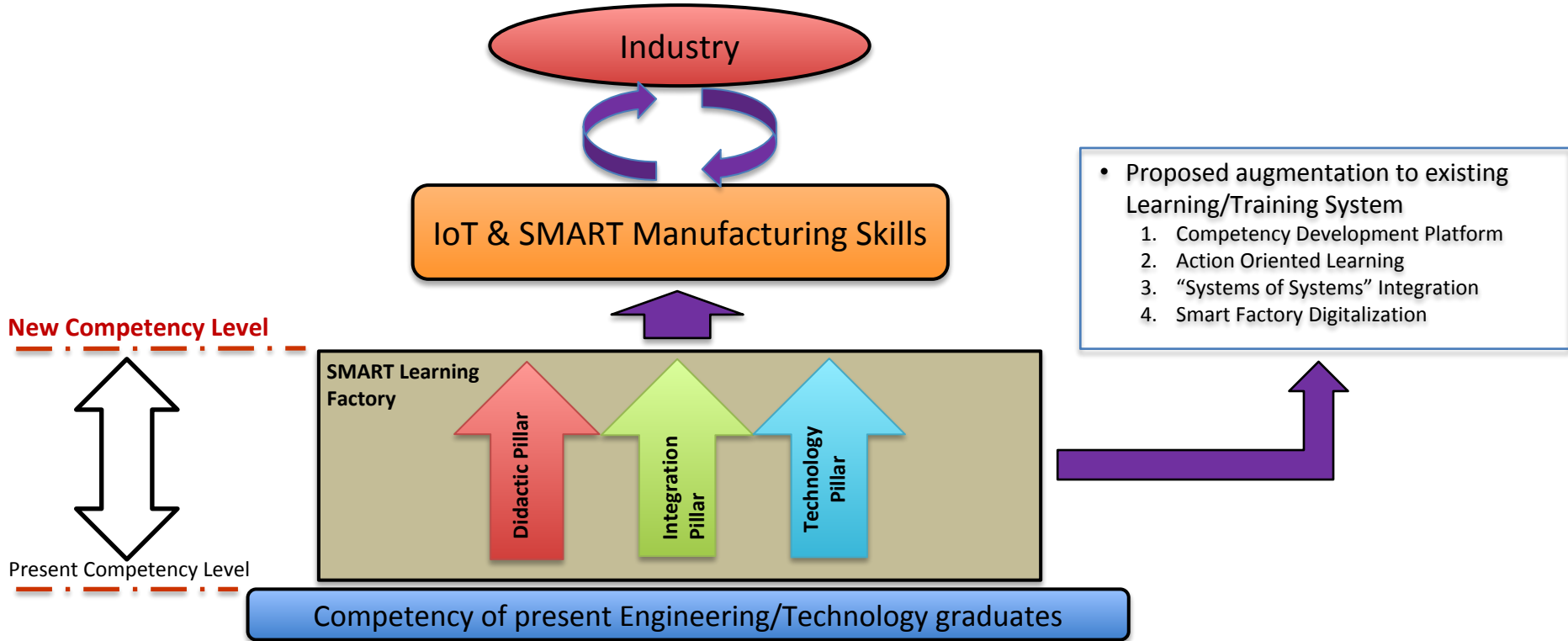



# SMART LEARNING FACTORY – OPERATIONAL PLAN

**Engagement/Training Platform:**  
Workshop/Training/Certifications for Students & Industry

**Competency  
Development Platform:**  
(BS/MS/PhD)

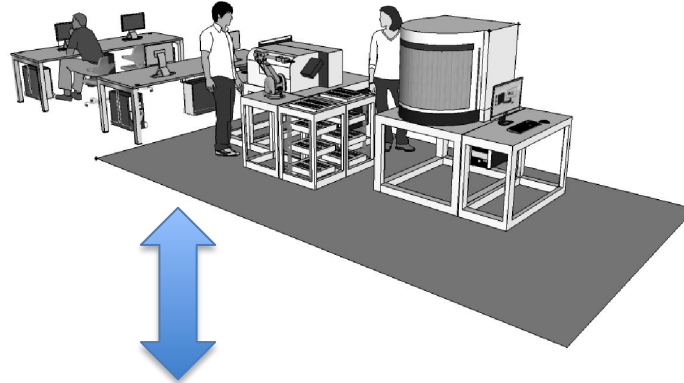

**Innovation Platform:**  
Makerspace,  
Innovation Space,  
Incubator,  
Simulated Pilot Factory

**Applied Research Platform**  
(Capstone, New Product/Technology Development, Emerging  
Manufacturing Competence Areas)

# FRAMEWORK – SMART LEARNING FACTORY

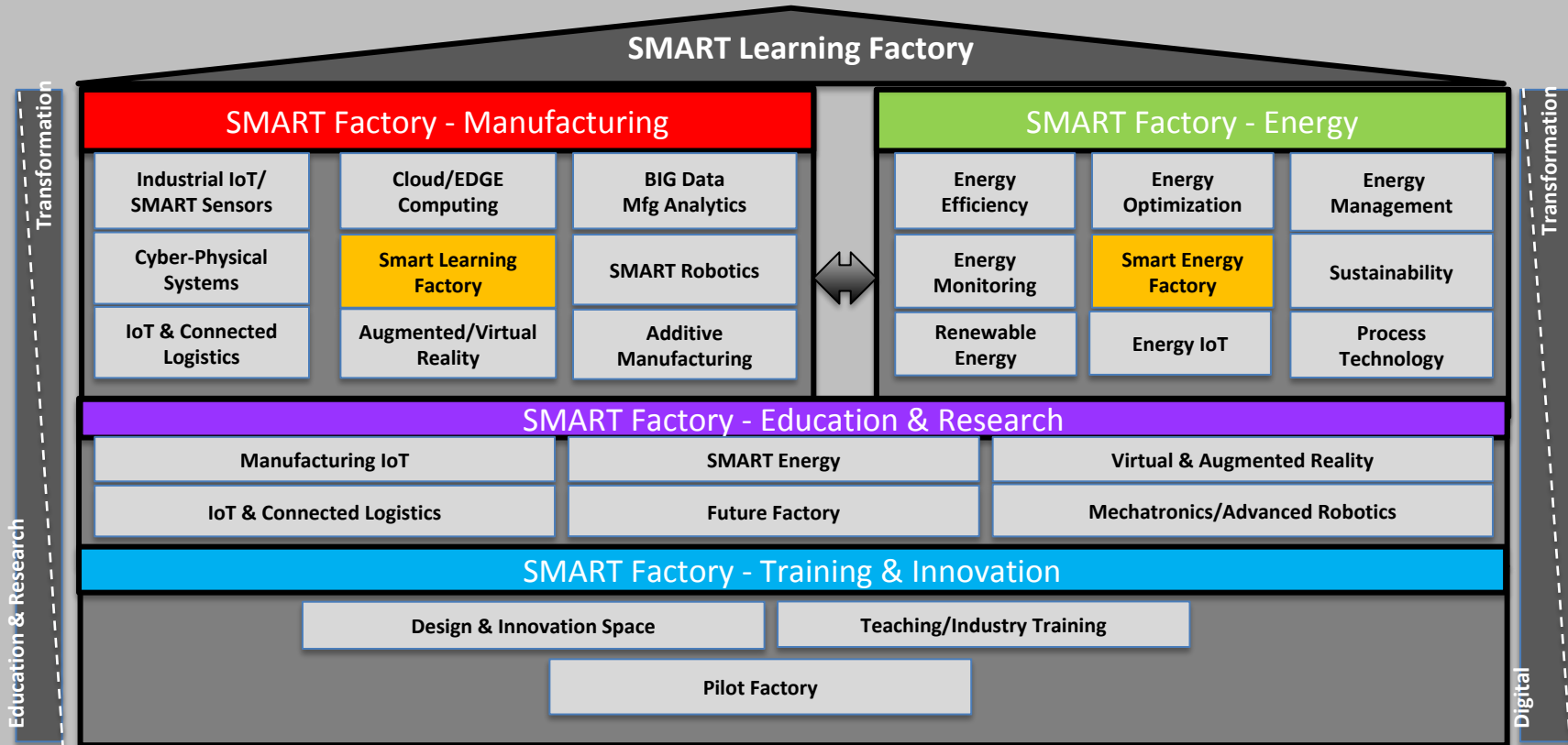

# SMART LEARNING FACTORY - COMPETENCE AREAS

- **Industrial Internet** - *Develop competency on integrating and linking of big data, analytical tools and wireless networks with physical and industrial equipment, and cross-company information integration across the value chain from supplier to customer and from shop-floor to top floor.*
- **Manufacturing Analytics** – *Develop competency in the use of Big Data to improve manufacturing processes, product quality and productivity, manage the supply chain, and optimize machine and system level operations.*
- **Cyber-Physical Systems** – *Develop competency in simulation of the cyber-production value networks and process within the value chain to be stored in the manufacturing cloud. Optimization performed based on real-time data from intelligent systems.*
- **Manufacturing CPPS** – *A manufacturing cyber-physical production system (CPPS) from a distributed network of connected systems and machines with capabilities for intelligent management and provide solutions for all users involved in the manufacturing lifecycle.*
- **IoT & Connected Logistics** – *Develop competency in the use of cloud-based GPS, Radio Frequency Identification (RFID) technologies, barcode scanners, and IoT enabled mobile devices to capture, share, and track inventory data across the enterprise using the cloud.*
- **SMART Robotics** – *Autonomous and collaborative industrial robots with integrated sensors and standardized interfaces.*
- **Augmented/Virtual Reality** – *Develop competency in AR/VR capabilities for maintenance, assembly, logistics, factory layout and implementing all kinds of SOP's in a production environment. Display of information e.g. through Google glasses, Hololens, Oculus VR, etc.*
- **Additive Manufacturing** – *Develop competency in 3D printing particularly for prototypes, spare parts, and mass customization of parts for decentralized facilities to reduce transport and inventory cost.*







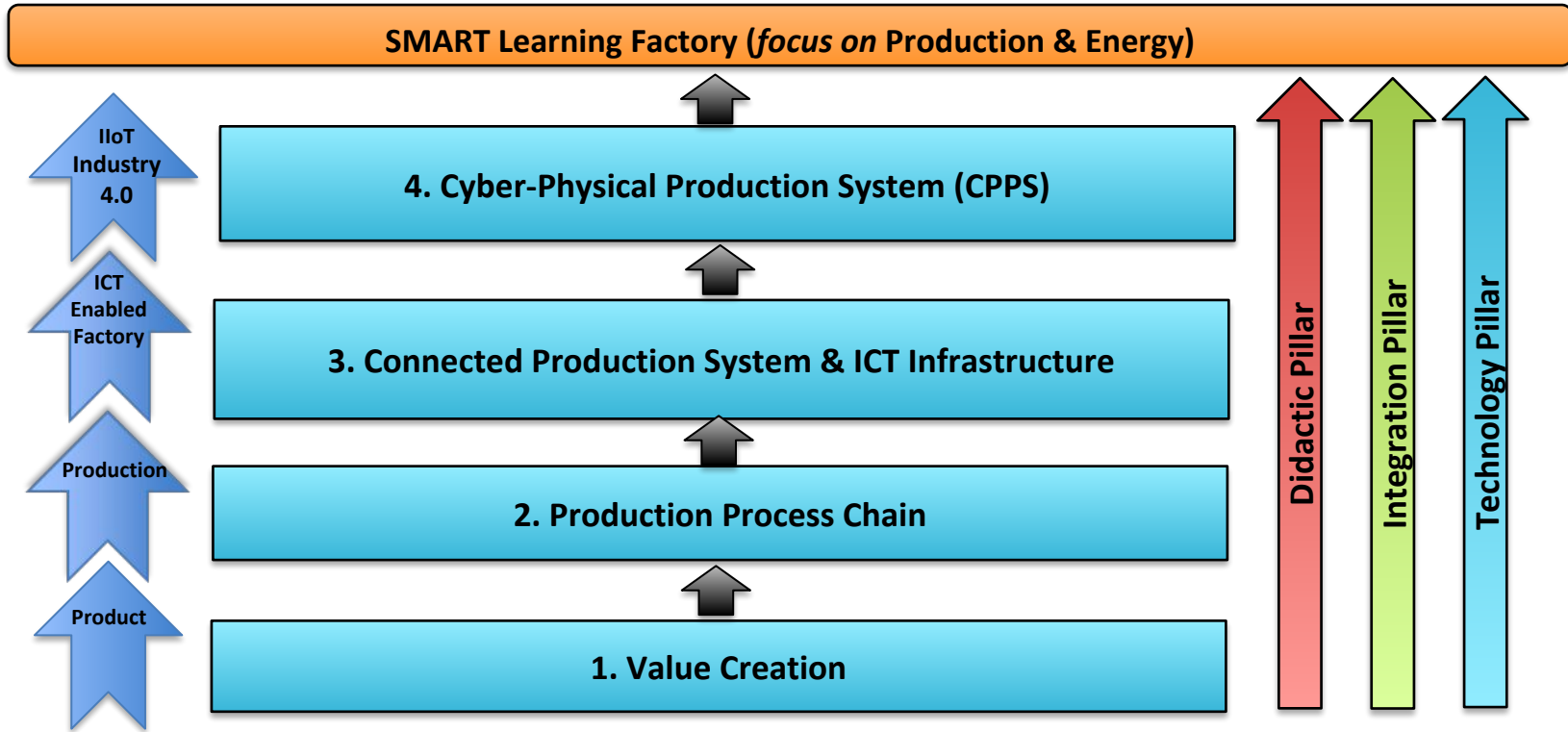

# SMART ENERGY FACTORY - COMPETENCE AREAS

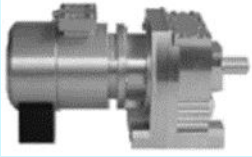
- **Energy IoT** – Develop competence based on insight derived from plant networking data collected from internet connected devices to facilitate real-time decision making, visualize energy consumption trends, determine future energy use, diagnose specific areas of wasted energy, and use of cyber-intelligence for control and optimization of process and systems.
- **Energy Efficiency** – Develop competence to reduce consumption and demand for energy in machines, systems, and processes.
- **Energy Optimization** – Develop competence for energy savings through the optimization of processes through mechanical or process engineering revamps by appropriate modifications made to the system. The other approach is through the use of captured process data and optimization is generated using intelligent control techniques.
- **Energy Management** – Develop competence on the optimal use of energy which includes the areas of measurement, control, and management strategies, to improve the efficiency, productivity and sustainable use of energy.
- **Energy Monitoring** – Develop competence on use of hardware and software technologies connected to energy resources to monitor energy consumption.
- **Renewable Energy** – Develop competence on energy generated from natural processes such as geothermal, wind, solar, hydropower, biomass, biofuels, etc.
- **Process Analysis & Technology** – Develop competence on industry-driven operations and technology in the area of knowledge based production and intelligent process control to make processes more efficient and sustainable.

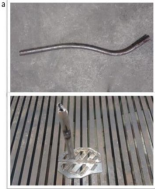
# 4-STAGES OF THE SMART LEARNING FACTORY

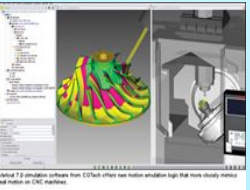

# SMART LEARNING FACTORY – STAGES 1 & 2

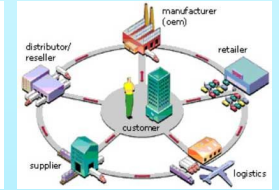
Learning Factory						
<b>Products</b>						
<b>Process Chain</b>	 <p>Production Planning</p>	 <p>Product Design</p>	 <p>Production Automation</p>	 <p>Production Operations</p>	 <p>Production Logistics</p>	 <p>Supply Chain</p>
<b>Associated Topics</b>	<p>Production Systems</p> <p>Production Control</p> <p>Project Management</p> <p>Industrial Controls</p>	<p>Design &amp; System Thinking</p> <p>Industrial Logistics</p> <p>CAx/CAE/FEA</p> <p>Sensors &amp; Actuators</p>	<p>Production Planning</p> <p>Production Automation</p> <p>Product Lifecycle Management</p> <p>Robotics &amp; Control Systems</p>	<p>Quality Control</p> <p>Lean Manufacturing</p> <p>Operations Planning</p> <p>Sustainability &amp; Efficiency</p>	<p>Advanced Manufacturing</p> <p>Production Logistics</p> <p>Inventory Management</p> <p>Design for Assembly</p>	<p>Manufacturing Processes</p> <p>Advanced Processes</p> <p>Advanced Machining</p> <p>Design for Manufacturing</p>

# STAGE 3 - CONNECTED SYSTEM & ICT INFRASTRUCTURE

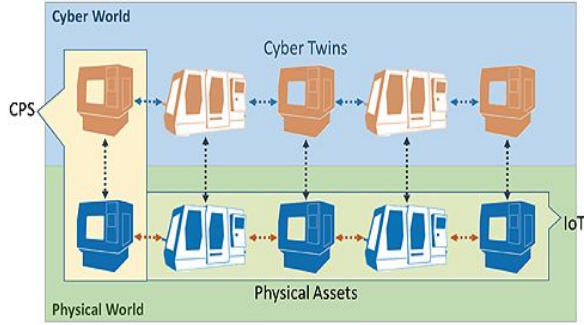

- **Goal:** Establish an ICT (Info. & Comm. Technologies) infrastructure to interconnect the physical assets of the value chain.
- **Purpose:** To acquire and share real-time digital information among customers, suppliers, processes, machines and operators.
- **Technology:** “Cloud-based data/IoT” platform based on the CPS-5C architecture
  - Storage of data streamed from production and sensors monitoring machine functions
  - Connectivity between sensors at the machine-level, factory-level (Manufacturing Execution Systems – MES), and Enterprise-level data (ERP)

## WHAT?

- Integrate ICT Infrastructure in the Learning Factory to interconnect the physical assets of the production system.



## HOW?

- A Cloud-based data/IoT platform
- 5C-CPS architecture for cyber-physical systems in manufacturing
- Wired and wireless Sensor Networks
- Data to information conversion systems
- Telepresence systems and Real-Time information display

## WHY?

- Evaluate and manage information in the production system in Real-Time

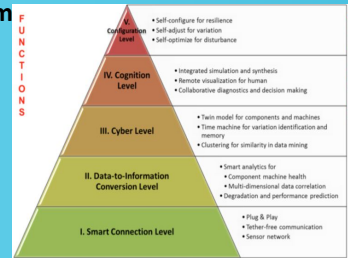

# STAGE 3 : CPS-5C ARCHITECTURE

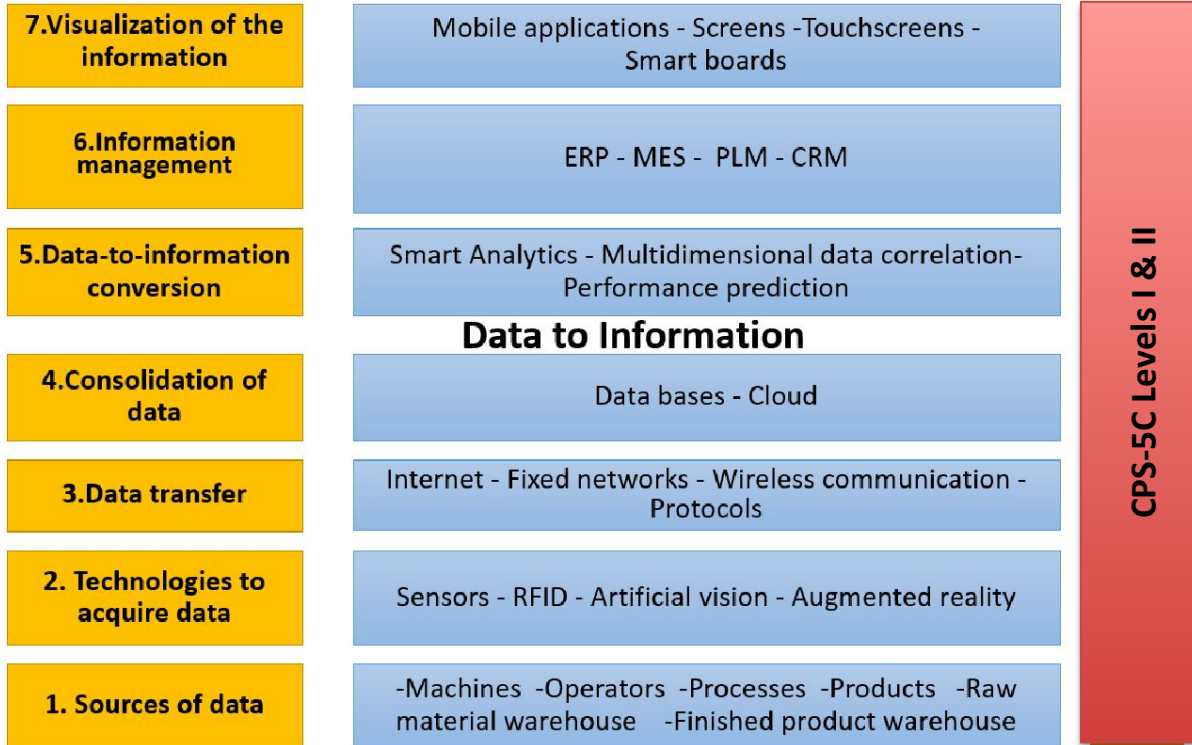



# STAGE 4 - CYBER PHYSICAL PRODUCTION SYSTEM

## GOAL:

- Implementation of CPS-5C Levels III, IV, & V
- A Cyber-Physical Production System to achieve optimal production operations

## Layer 2:

### Cyber Level:

- A central information hub (Cloud) to collect sensor data from every connected machine in the network
- A simulated digital twin of machines and production processes
- Analytics to perform variation identification

### Cognition Level:

- Machine and production processes condition and quality testing.
- Correlation analysis using the digital twin of machines and processes.
- Collaborative diagnostics and decision making

### Configuration/Adaptive Control Level:

- Distributed & Supervisory Control System (DCS & SCADA) for feedback control action to the machines and processes.
- Machines self-configure and self-adaptive.

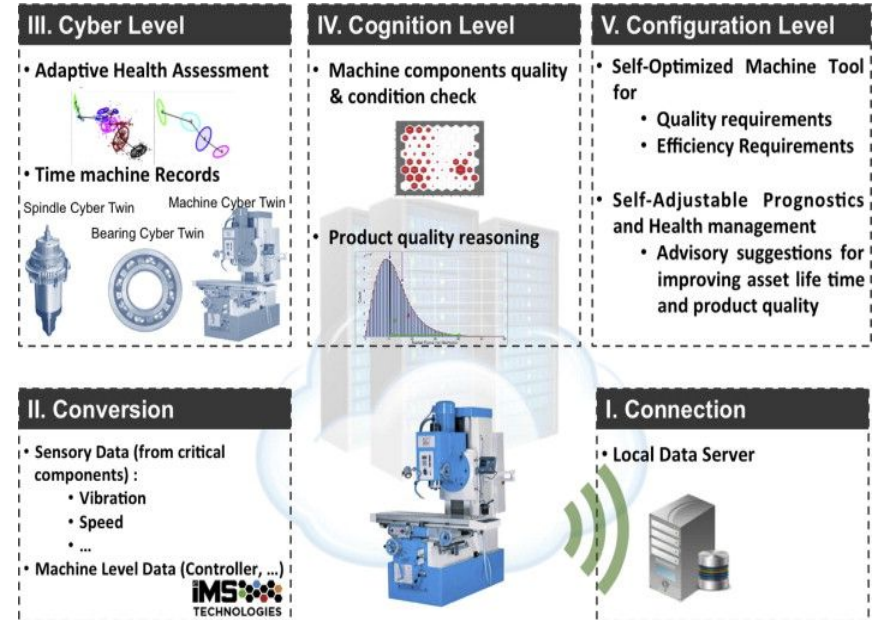

# SMART ENERGY FACTORY - OBJECTIVES

## Facts:

- Productivity increased by more than 260% in the last 60 years
- Gains in energy efficiency have only been modest during same period
- US energy costs have doubled in the last decade
- Manufacturing consumes 31.4% of all energy produced
- Energy costs are \$1.8 trillion per year (more than India's GDP)

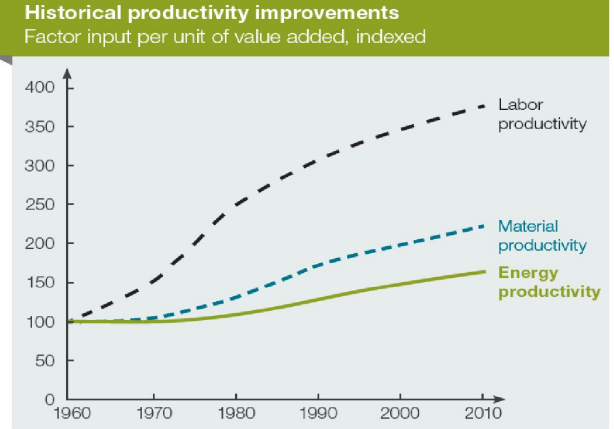

Source: U.S. Energy Information Administration; Federal Bureau for the Environment

## SMART Energy Factory Objectives:

- Prepare the next generation of engineers with knowledge, skills and aptitude to help industries significantly reduce consumption and demand for energy resources.
- Provide competency based action-oriented learning in energy efficiency.
- A platform for teaching and applied research in the field of energy efficiency.

# SMART ENERGY FACTORY - CHARACTERISTICS

## Factory Characteristics:

- It is a real production environment, using real manufacturing machinery and industrial control technologies.
- A system for creating value will be defined and implemented using a multi-stage process that include electrical machines, drives, thermal, hydraulics, compressed air systems, pumps, fans, among other things.
- Factory will integrate intelligent control and IoT enabled technologies to reduce energy demand and improve efficiency of systems.
- Students will work in the factory to identify sources of waste in the system, implement and test improvements, offer recommendations for energy management, and calculate the resulting savings.
- Students who demonstrate their proficiency by successfully completing a project in the factory are recognized using badges.

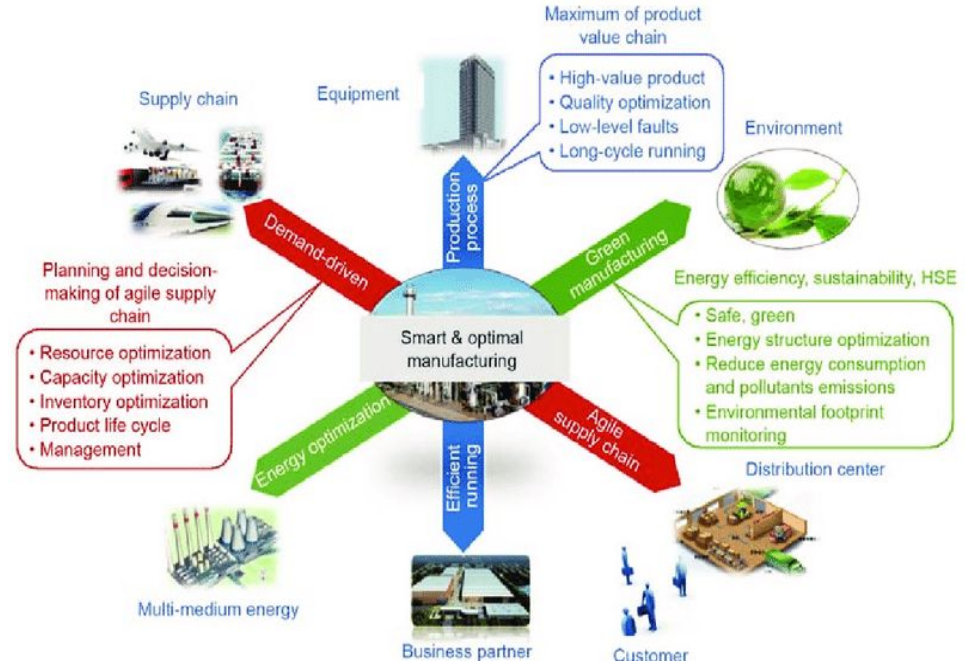

# SMART ENERGY FACTORY - ENERGY PROCESS CHAIN

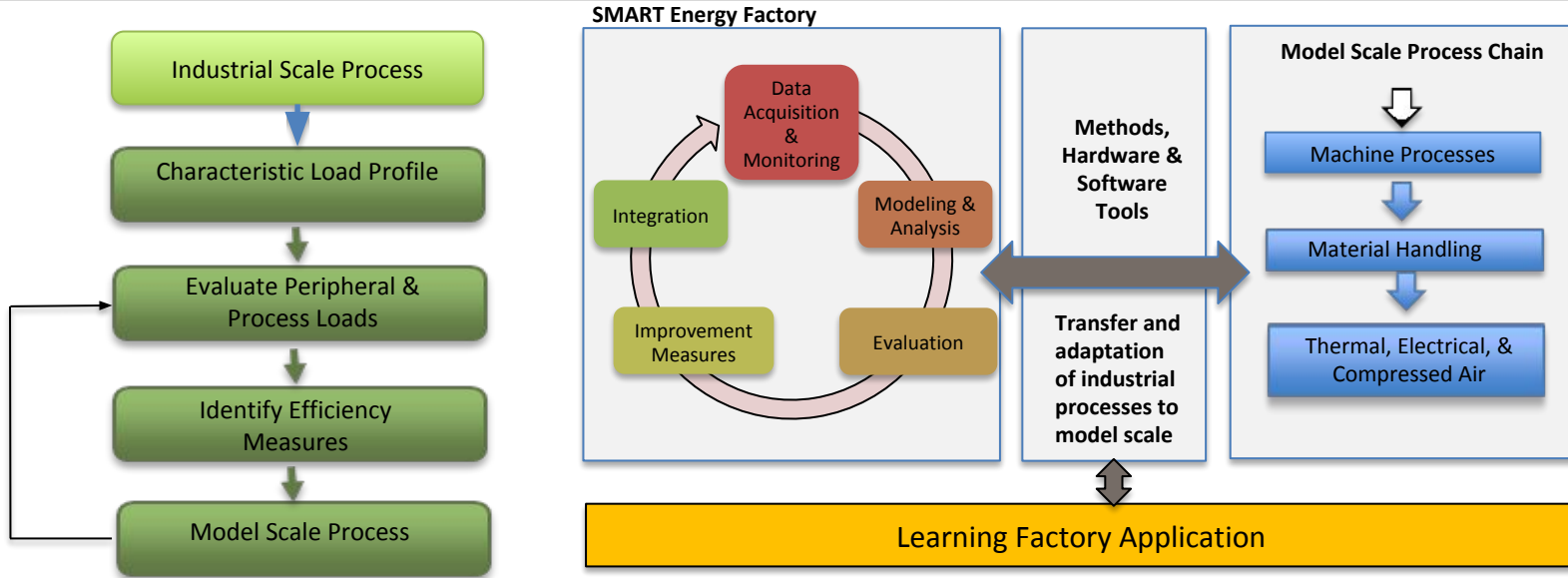

## WHAT?

- Process Chain for Energy Efficiency

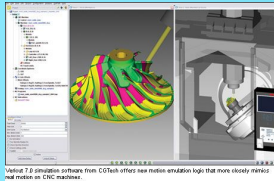

## HOW?

- Installation of metering equipment for all energy demands and infrastructure to export and store data.
- Visualization tools for acquired data
- Analysis and evaluation of improvement measures covering different areas of energy efficiency.



## WHY?

- To DEVELOP & INTEGRATE the Value Chain concept for an energy system

# SMART LEARNING FACTORY – STRATEGIC RESEARCH AREAS

- The ‘SMART Factory’ Research Areas:
  - *Manufacturing IoT (Analytics & Operational Intelligence)*
  - *Future Factory (Safety & Ergonomics)*
  - *VR/AR (Mixed Reality)*
  - *Mechatronics/Autonomous/Collaborative Robotics*
  - *IoT & Connected Logistics*
  - *SMART Energy*

# MANUFACTURING IOT - RESEARCH COMPETENCE AREAS

- **Motivation** – Manufacturing represents the largest use case for IoT technologies across all industries globally. Adoption of the IoT as a strategic technology area require industries to converge their physical assets with the digital.
- **Manufacturing IoT** – Research to connect physical and digital assets, such as manufacturing processes, machines, automation, objects, people, as well as a variety of product and manufacturing process parameters to become a part of an interconnected and collaborating network, managed using smart analytics and machine intelligence to diagnose, improve and optimize machine and system level operations.

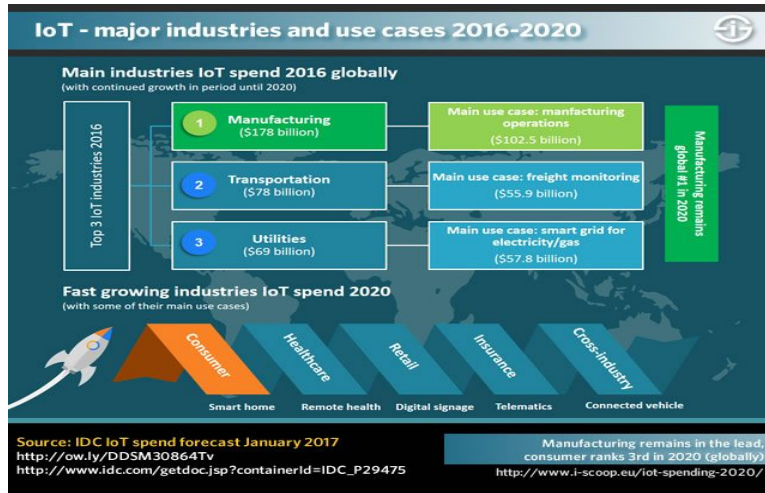



# FUTURE FACTORY – RESEARCH COMPETENCE AREAS

- **Motivation** – *Digitalization is transforming the factory floor. New forms of human-machine interaction is necessary to prepare industrial workers for the digital workplace.*
- **Future Factory** – *Research to shape the digital transformation of the workspace and factory floors to show what industrial work could look like with the fusing of the digital with the physical world, and what this means for the worker. Research is necessary to drive these changes forward with key innovations such as Digital Twin, 5G, machine learning, cognitive systems, safe human-robot collaboration, and access to greater data resources.*



# VR/AR - RESEARCH COMPETENCE AREAS

- **Motivation** – More than 1/3<sup>rd</sup> of industries will have VR/AR technology deployed and adopted by 2018 to increase efficiency and productivity of manufacturing operations. The fusing of the digital and physical world required new forms of worker-machine interaction in the digital workplace.
- **VR/AR (Mixed Reality)** – Research on the use of VR/AR (Mixed Reality) in the complex assembly planning of manufactured products, maintenance procedures for equipment to eliminate errors, expert support via telepresence, quality assurance (cloud based parts database), collaborative automation, product design, facilities layout planning, etc.

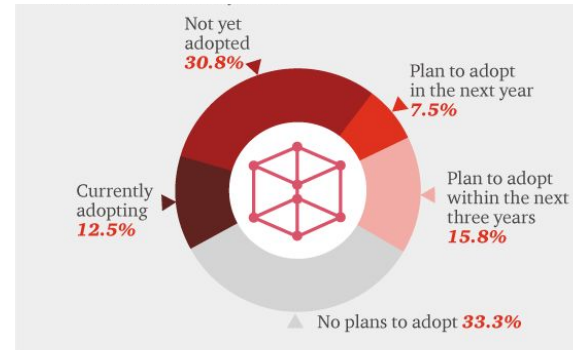



# MECHATRONICS/ADVANCED ROBOTICS - RESEARCH COMPETENCE AREAS

- **Motivation** – *New generation of industrial robotics is transforming the industrial workplace, and advancing how robots are deployed in manufacturing. Also develop capabilities into the synergistic integration of mechanical and electronic control systems*
- **Advanced Industrial Robotics** – *Research that will look into bringing advanced control systems and robots into human workspace via coexistence, interaction, and collaboration. Emerging research includes, but not limited to the field of safety in Human-Robot Interaction, task and interaction planning, use of AI, machine learning, and Natural Language Processing (NLP) to improve the use and the deployment of collaborative robotics in industrial settings.*



# IOT & CONNECTED LOGISTICS - RESEARCH COMPETENCE AREAS

- **Motivation** – *With the sheer number of systems and processes connected over the internet, IoT technologies are transforming the tracking, transportation, and management of inventory in the supply chain ecosystem*
- **IoT & Connected Logistics** – *Research into the supply chain ecosystems leveraged through the use of cloud-powered IoT technologies and IoT-connected devices for the tracking and management of the assets within the value chain to provide end-to-end visibility and control across the supply chain. Also research into use of data-driven automation and big-data analytics to make the system much more effective, predictable, and cost-efficient.*

The role of IoT in a sense-decide-respond supply chain

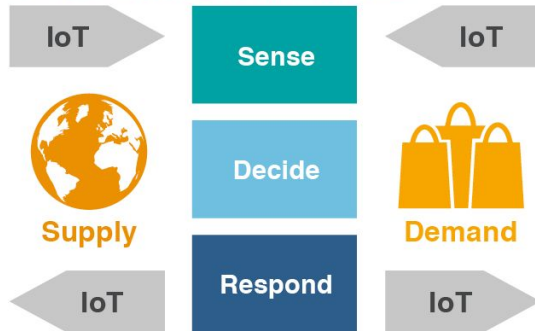

Source: SCM World 2016



# SMART ENERGY - RESEARCH COMPETENCE AREAS

- **Motivation** – Help industries significantly reduce consumption and demand for energy resources
- **Energy** – Research into energy efficiency and optimization of industrial systems and its processes, especially components of thermal energy, fluid power, and compressed air systems. Research will also extend into use of data collected from IoT-connected devices to visualize energy consumption trends, energy demand prediction, diagnostics of energy systems, and use of data and intelligence for control and optimization. Other research areas may include use of renewable energy production (solar, wind, and biofuels) and energy storage (hydrogen and battery technologies)

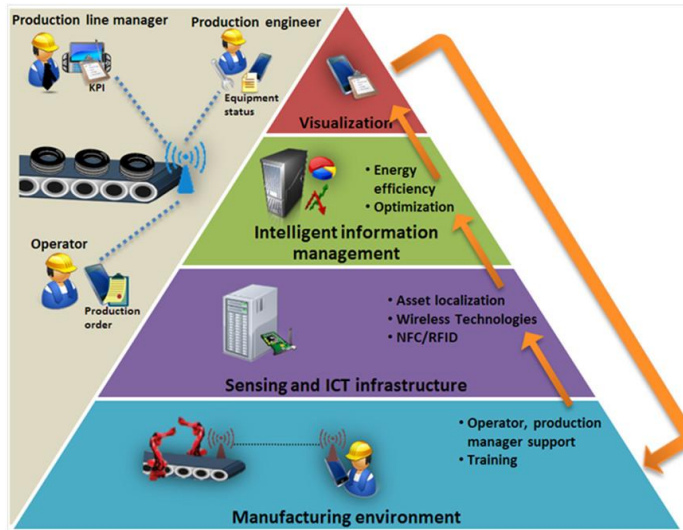

# SUMMARY

- The objective is to reduce course silos by deliberately fusing the interconnection bet courses
- Use the Smart Learning Factory as the platform to unify projects in the MFET/MET/EET programs.
- The SLF is a new concept being pursued in SOET to support learn-by-doing, project-based learning, learning in context, and interdisciplinary/**multidisciplinary** learning approaches.
- Functionally, the SLF is a replica of an actual factory designed to offer students the experience of a real production environment at an industry-relevant scale.
- Using the SLF platform, our goal is to develop activities that will deliberately connect the learning across multiple courses-within the same semester, same year, and bet different years.
- This will involve integration of activities in design, manufacturing systems, production processes, production management, automation, energy, information technology, teamwork, cooperation, communications, and project management.
- A student progressing from freshman through senior year will finally be able to understand the interconnection of content between different courses and gain a holistic perspective of the interdependent structures of a manufacturing production system.

Thank you  
Q&A