

Utah State University

DigitalCommons@USU

Space Dynamics Lab Publications

Space Dynamics Lab

9-15-1998

Cooling SABER with a miniature pulse tube refrigerator

Scott M. Jensen
Utah State University

J. Clair Batty
Utah State University

William A. Roettker
NASA Langley Research Center

Matthew J. Felt
Utah State University

Follow this and additional works at: https://digitalcommons.usu.edu/sdl_pubs

 Part of the [Aerospace Engineering Commons](#), and the [Aviation and Space Education Commons](#)

Recommended Citation

Jensen, Scott M.; Batty, J. Clair; Roettker, William A.; and Felt, Matthew J., "Cooling SABER with a miniature pulse tube refrigerator" (1998). *Space Dynamics Lab Publications*. Paper 219.
https://digitalcommons.usu.edu/sdl_pubs/219

This Conference Paper is brought to you for free and open access by the Space Dynamics Lab at DigitalCommons@USU. It has been accepted for inclusion in Space Dynamics Lab Publications by an authorized administrator of DigitalCommons@USU. For more information, please contact digitalcommons@usu.edu.



PROCEEDINGS OF SPIE

[SPIDigitalLibrary.org/conference-proceedings-of-spie](https://spiedigitallibrary.org/conference-proceedings-of-spie)

Cooling SABER with a miniature pulse tube refrigerator

Scott M. Jensen, J. Clair Batty, William A. Roettker,
Matthew J. Felt

Scott M. Jensen, J. Clair Batty, William A. Roettker, Matthew J. Felt, "Cooling SABER with a miniature pulse tube refrigerator," Proc. SPIE 3435, Cryogenic Optical Systems and Instruments VIII, (17 September 1998); doi: 10.1117/12.323740

SPIE.

Event: SPIE's International Symposium on Optical Science, Engineering, and Instrumentation, 1998, San Diego, CA, United States

Cooling SABER with a miniature pulse tube refrigerator

Scott M. Jensen^a, J. Clair Batty^a, William A. Roettker^b, and Matthew J. Felt^a

^aUtah State University/Space Dynamics Laboratory
1695 North Research Park Way, Logan, Utah 84341

^bNASA Langley Research Center
MS 431, Hampton, VA, 23681

Utah State University/Space Dynamics Laboratory (USU/SDL), teaming with NASA Langley Research Center, is currently building the Sounding of the Atmosphere using Broadband Emission Radiometry (SABER) instrument. Stringent mass and power constraints, together with a greater than two year mission life, led to the selection of a TRW miniature pulse tube refrigerator to cool SABER's infrared detectors to the required temperature of 75 K.

This paper provides an overview of the SABER thermal management plan and the challenges encountered in matching the refrigerator characteristics with instrument performance requirements under the broadly variant space environments expected for this mission. Innovative technologies were developed to keep heat loads within the limited cooling capacity of the miniature refrigerator, as well as mechanically isolating but thermally connecting the refrigerator cold block to the focal plane assembly (FPA). A passive radiator will maintain the SABER telescope at an average temperature of 230 K while a separate radiator will reject heat from the refrigerator and electronics at approximately 260 K.

Significant breadboard tests of various components of the SABER instrument have taken place and the details of one of these will be discussed. The test included attaching a miniature mechanical refrigerator, borrowed from the Air Force, to the SABER FPA. This opportunity gave the SABER team a significant head start in learning about integrating and testing issues related with the TRW miniature pulse tube refrigerator.

SABER is scheduled to be launched in January 2000 as the primary instrument of NASA's TIMED (Thermosphere-Ionosphere-Mesosphere Energetics and Dynamics) spacecraft. The TIMED program is being managed by the Applied Physics Laboratory at Johns Hopkins University.

Keywords: FiST, SABER, TIMED, infrared telescope, TRW miniature pulse tube refrigerator.

1.0 INTRODUCTION

Utah State University/Space Dynamics Laboratory, teaming with NASA Langley, is currently designing and building the SABER instrument shown in Figures 1 & 2. The SABER instrument is a 10-channel earth limb-scanning radiometer, which operates in the 1-17 μm region. Mission life for this instrument is 2 years at a 100 percent duty cycle. The TIMED spacecraft will orbit the earth at an altitude of 600 km in a circular orbit¹.

There are three separate temperature zones on the instrument which require very precise thermal control. These temperature zones are shown in Figure 3. The first of these zones is the telescope temperature zone, which consists of relay optics, a scanner assembly, and a set of baffles. This region must be controlled such that the maximum operating temperature does not exceed 250 K. Minimum temperature requirements are not as stringent; however, limitations on allowable heater power dictate that temperatures should not drift below 200 K. The parasitic and operational heat loads from the telescope will be dissipated by a passive radiator which looks into deep space and has been sized accordingly to meet the aforementioned criteria.

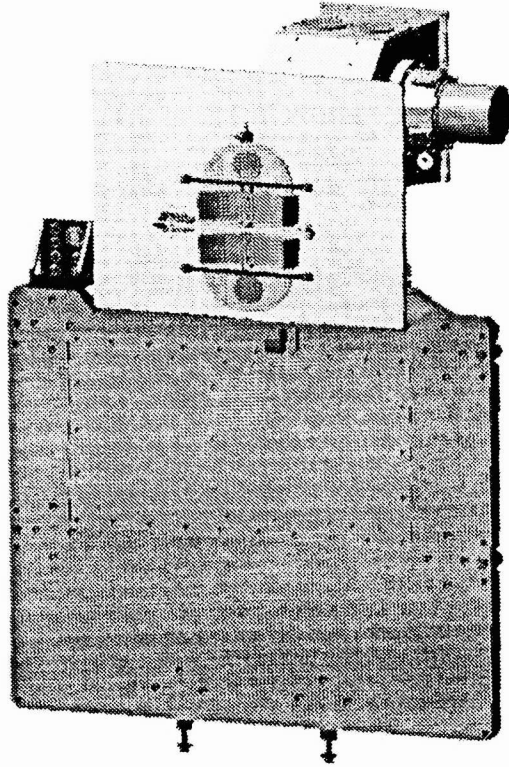

Figure 1. SABER front view.

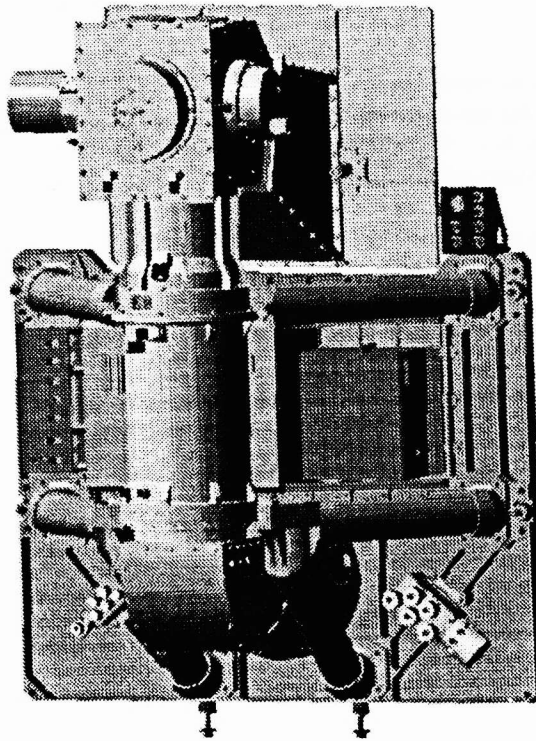

Figure 2. SABER back view.

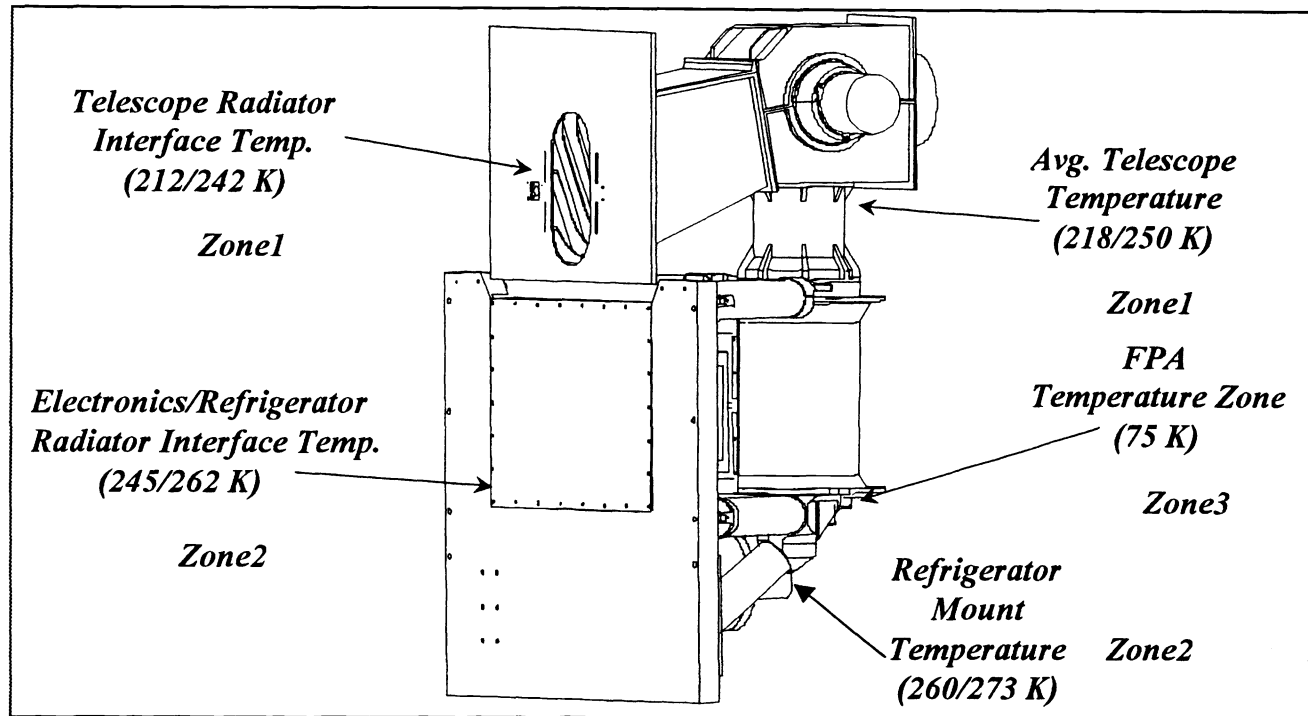

Figure 3. SABER temperature zones.

The second temperature zone encompasses the miniature cryogenic mechanical refrigerator, SABER electronics, and supporting structure. Because the reject temperature of the refrigerator plays an important role in overall cooling capacity, precise control of this zone is needed. The heat dissipated by the electronics and the refrigerator will be rejected by a passively controlled radiator, which will be maintained at temperatures between 250 K and 265 K.

The third and most critical temperature zone is that of the FPA. The FPA utilizes infrared detectors that must be cooled to less than 75 K for a 2 year period with a 100 percent duty cycle. The challenge with this temperature zone is to reduce the parasitic heat loads incident on the FPA to values within the range of the refrigerator selected (approximately 250 mW at 72 K cold block and a reject temperature of 287 K)². To accomplish this, a new technology was developed at USU/SDL, which utilizes high performance fibers in tension (i.e. Kevlar 49) to thermally isolate and mechanically support a cooled component such as a detector plane. This technology has been named FiST(Fiber Support Technology). Figure 4 is a picture of the SABER FPA support used during breadboard testing. Details of this support approach have been presented at previous SPIE meetings and will not be discussed here in detail.

A FiST breadboard model was connected, via a solder-less flexible thermal link, to a TRW miniature pulse tube refrigerator belonging to Phillips Laboratory. This provided a unique opportunity to learn a great deal about integrating the pulse tube refrigerator into the SABER instrument. It also provided an opportunity to characterize the thermal performance of the refrigerator base-lined for cooling the FPA on SABER.

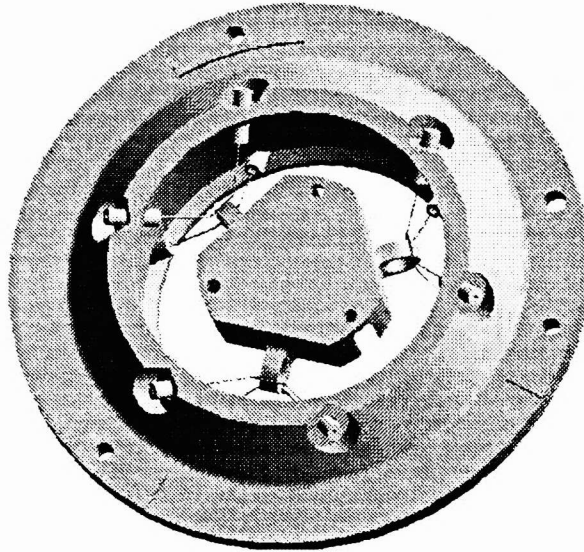

Figure 4. FiST FPA used during testing.

2.0 ANALYSIS

The infrared detectors used on the SABER FPA must be cooled to 75 K. Assuming a temperature difference of 3 K or less from the detectors to the refrigerator cold block, the cold block on the refrigerator would need to run at 72 K. Under these conditions, the TRW pulse tube refrigerator provides approximately 250 mW of cooling, with a reject temperature of 287 K, and an input power of 20 Watts to the compressor. The determination of actual heat loads to the refrigerator under test conditions was therefore of great interest.

The total heat load on the SABER FPA was predicted by computer modeling. Figure 5 shows the total predicted refrigerator heat load for SABER telescope cavity temperatures of 200 K, 220 K, 240 K and 260 K as a function of the surrounding spacecraft temperature. The majority of the heat being removed from the FPA is from radiation parasitics. The predictions shown in Figure 5 use an effective blanket emittance of .01. Results from the testing will be used to compare to predicted numbers and to aid in determining the actual emittance achieved.

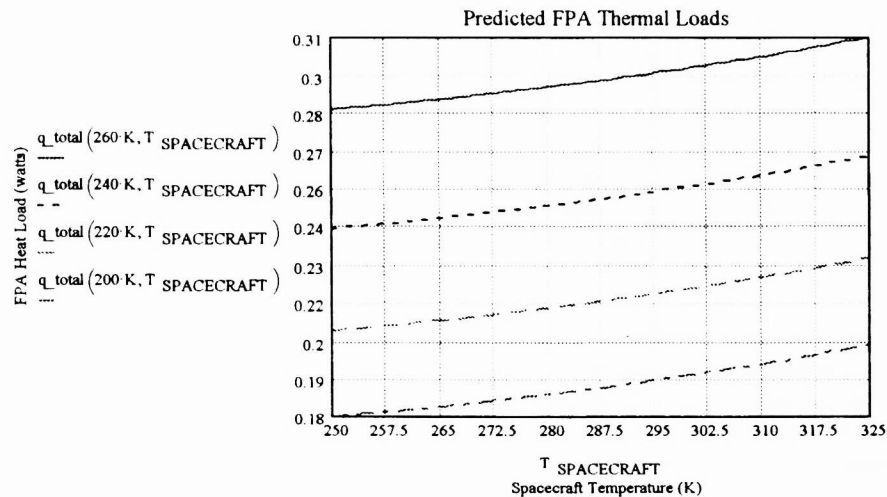

Figure 5. Predicted FPA thermal loads.

3.0 THERMAL TESTING OF THE SABER FPA

To correctly simulate the conditions in space, it was necessary to conduct the thermal testing of the SABER FPA setup in a vacuum dewar. A vacuum pump was connected to the dewar via a short four inch line to create the vacuum environment. A sketch of the test setup is shown in Figure 6 and is further discussed below.

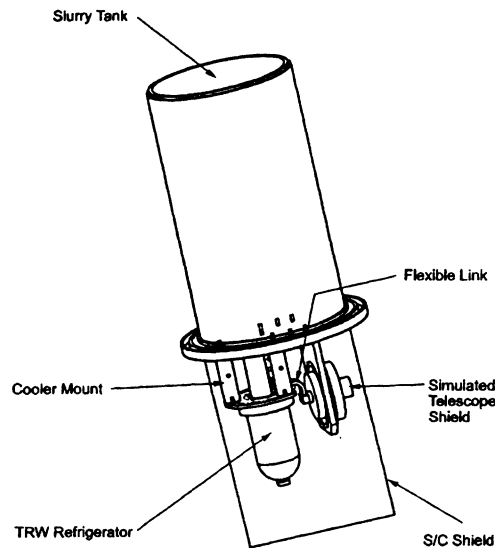

Figure 6. Sketch of test setup.

It was important to develop a mechanically stable and thermally dependable testing configuration to prevent any damage to the TRW pulse tube refrigerator. A cooling source was needed as a heat sink for the refrigerator as well as the other testing apparatus to properly simulate thermal conditions on orbit. The use of liquid nitrogen in the test dewar's cryogen tank would have provided excessive cooling, and could not be quickly removed from the test dewar in the event of a power loss.

A slurry mixture of alcohol and dry ice, which would reach a temperature of approximately 195 K, was determined to be the optimal cooling source. A special lid was made for the vacuum dewar that contained the slurry while thermally isolating it from the warm surroundings with a long conductive path. This lid provided a cold surface to which the testing apparatus could be mounted, and still made it possible to quickly remove the cold slurry if the test setup happened to lose power. See Figure 6.

It was necessary to vary the temperature of the outer hub of FiST between the operating extremes expected on orbit: 218 K and 240 K. These temperatures represent the cold and hot case environments. To achieve these temperatures, FiST was mounted on a 0.5 inch thick aluminum mount. The temperature of the mount was controlled by isolating it from the 195 K cold block with stainless steel washers and a heater placed on the outer hub of the FiST assembly. The heater was connected to a power supply, which was adjusted as needed according to the temperature of the hub.

The TRW miniature pulse refrigerator was mounted so that it could reject up to 17 watts of heat at a temperature no lower than 250 K. A mount consisting of three stainless steel cylinders provided the thermal impedance necessary to achieve this with minimum amounts of heat from attached heaters. The temperature of the mount was controlled using an active heating system, which continually monitored the temperature of the mount. A redundant heating system was included on the refrigerator mount in case the main system should fail.

The refrigerator cold block was connected to the cold block of FiST with a solderless flexible thermal link made by SDL. This link provides a good thermal connection (2.3 Kelvin's per watt) between the SABER FPA and the TRW refrigerator while maintaining mechanical isolation through the flexibility of the link. Temperature sensing diodes were connected to each end of the link to monitor the heat transfer through the link. This link was calibrated prior to the test so

that once the temperature gradient across the link was known, the heat load going through the FPA system would also be known.

The radiation environment of the spacecraft was simulated by covering the entire setup with an aluminum shroud whose interior was painted black with Aeroglaze Z306 flat black paint. The shroud was isolated from the cold block of the dewar by mounting it on three small L-brackets. The temperature of the shroud was controlled between 263 K to 325 K, the spacecraft internal environment extremes, in the same manner as that of the refrigerator mount.

The radiation environment for the focal plane assembly was simulated by placing a small shroud, similar to the one described above, over FiST. The heater on this shroud was attached to a power source and heat was applied as necessary to maintain a temperature between 218 K and 240 K.

Nine separate configurations were tested during the one and a half months that the refrigerator remained at SDL. The first six configurations were used for trouble shooting the test setup as well as trouble shooting the configuration of the FiST FPA breadboard assembly. The results in this report will be for the last 3 configurations, which are referred to as tests 7, 8 and 9. The temperature profiles for each of these tests are shown in Figures 7-9.

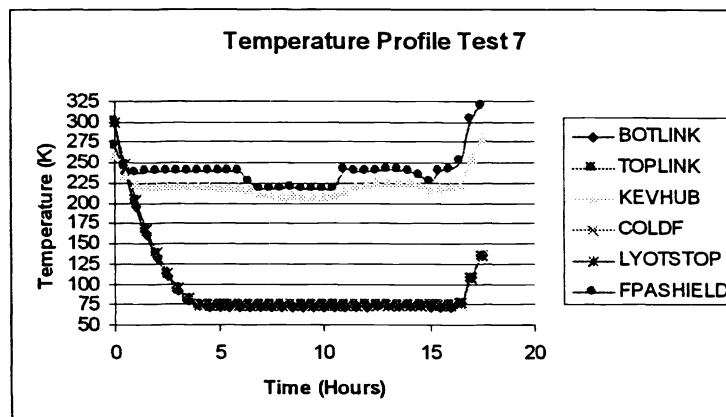

Figure 7. Temperature profile for test 7.

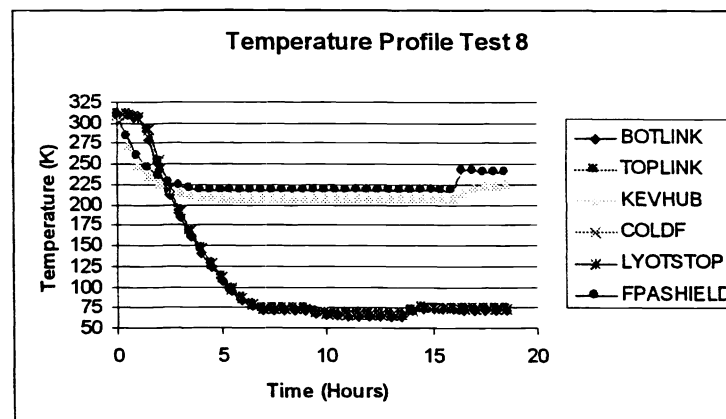

Figure 8. Temperature profile for test 8.

The start-ups in temperature control mode would cause a compressor trip error and subsequent refrigerator shut down. Manually bringing the refrigerator cold block down to temperature in stroke control mode was

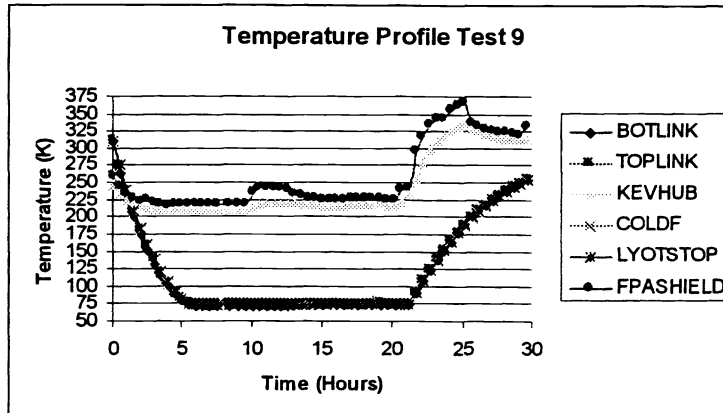

Figure 9. Temperature profile for test 9.

accomplished by adjusting the stroke and monitoring compressor power to ensure that the power did not exceed 24 watts. A stroke profile for tests seven, eight, and nine is shown in Figure 10. Notice that initially, in all tests, the stroke profile is a step function. This is because the stroke control was manually set to that particular value. Once the cold block began to approach 72 K, the electronics would be set to temperature control mode. At this point, the stroke profile smooths out as the computer continually monitors performance.

The cooling trend for all the tests is also well seen by inspecting the compressor power profiles and temperature profiles for each of the tests. As mentioned previously, the stroke was manually adjusted at the beginning of the test to keep the power on the compressor to a maximum, approximately 22-24 watts. Figure 11 shows the compressor power data obtained for each of the tests. From this data, the heat load to the FPA can be calculated by knowing the compressor power and the reject temperature of the refrigerator mount.

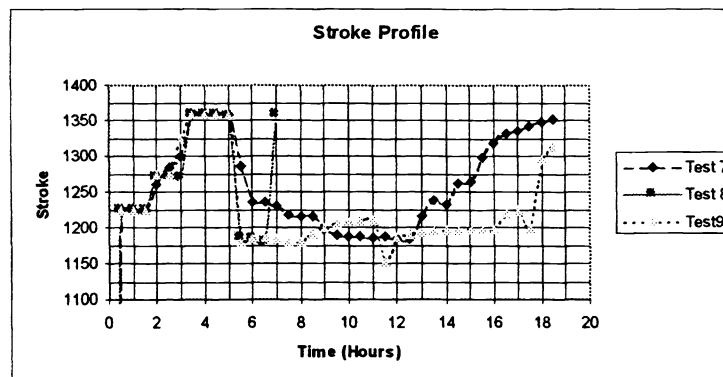

Figure 10. Stroke profile.

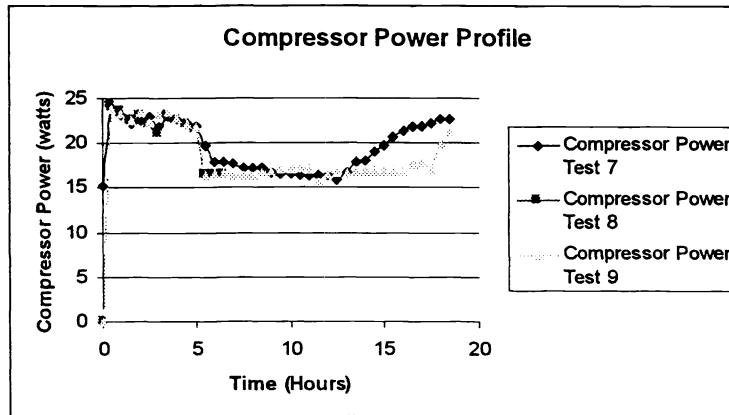

Figure 11. Compressor power profile for all tests.

Using the compressor power data and information provided by TRW, the heat load to the SABER FPA can be determined. Results from this calculation are shown in Figure 12. For this test, a calibrated thermal link was also used and provided us an alternative method for computing the FPA heat loads. By knowing the temperature difference across the link, the predicted heat load coming across the link could be calculated. These results are shown in Figure 13.

The plateaus in the heat load data represent test points of interest. In modeling the SABER instrument, the goal has been to predict the extreme hot and cold cases, which bound the thermal performance of the instrument. In testing the FPA, the hot and cold case boundary conditions were used to provide the test points. For the hot case, the simulated spacecraft shield temperature was set to 325 K, the simulated telescope cavity shield was set to 240 K, and the reject temperature of the refrigerator was set to 284 K. For the cold case, the simulated spacecraft shield temperature was set to 263 K, the simulated telescope cavity shield was set to 218 K, and the reject temperature of the refrigerator was set to 273 K. The heat loads obtained at these bounds would then provide the hot and cold case extreme heat loads on the SABER FPA.

Referring to point A on Figures 12 & 13 provides the first test point of interest. This point represents a cold case operating scenario. The heat load on the FPA system at this point was calculated to be approximately 240 mW according to data provided by TRW from compressor power charts. Heat loads of approximately 290 mW for the same test data point were calculated based on the temperature drop across the calibrated thermal link. The simulated detector power

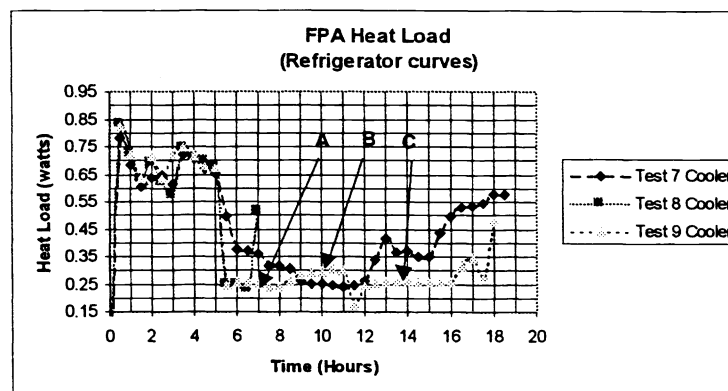

Figure 12. FPA Heat Load from refrigerator curves.

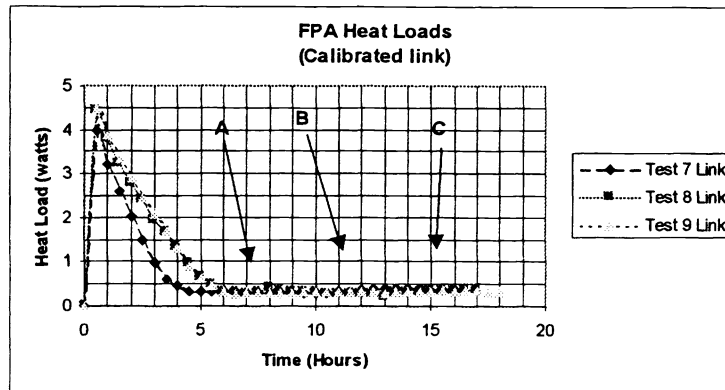

Figure 13. FPA heat loads calculated from calibrated thermal link.

dissipated on the FPA is not included in these results. To obtain the total FPA heat loading, another 44 mW needs to be added to the FPA heat load numbers presented in this report.

The 50-mW discrepancy in predicted heat loads is somewhat of a mystery, however, there are a few possibilities. The curves provided by TRW to predict the heat loads from the compressor power are based on average performance curves from the pulse tube refrigerators TRW's built to date. These average performance curves are likely different than the actual performance observed during the testing of the SABER FPA. The power readings from the electronics provided by TRW, as well as the equipment used by SDL to measure temperature, are likely another source of error. These units were not calibrated prior to testing. It is also important to note that the thermal link was in a significant radiation environment during the testing, which would effect the accuracy of the temperature reading across the link.

Regardless of the cause, the power drawn by the compressor under this cold case scenario matched reasonably well with published data for the reject temperature and heat loads experienced during this test. Based on this information, the heat loads based on the compressor power are reasonable.

Point B on Figures 12 & 13 represent a second data point of interest in which the reject temperature of the refrigerator was held at 273 K, the spacecraft shield was held at 263 K, but the simulated telescope cavity shield was increased from 218 K to 240 K. As seen by the predicted heat load charts, the predicted numbers moved up by about 60 mW.

The plan was to obtain data for a final point corresponding to the hot case scenario described previously. During these attempts, an anomaly in the refrigerator operation was discovered and has since been explained by TRW. As the test progressed and the heat reject temperature of the refrigerator was increased, (i.e. 284 K) a gradual and steady increase in compressor power, even after the temperature difference across the link had settled out, was observed. It was learned from TRW that the refrigerator being used had been previously operated for an extended period of time at approximately 373 K, which is well above its operating limit. This caused an internal contamination problem that becomes evident the longer the cooler is operated. TRW has observed this same anomaly of the compressor power slowly ramping up over an extended period of time³.

During test #9, a data point, which could represent a nominal on orbit thermal boundary for the system, was sought. The boundary conditions were set to the following temperatures, which represent nominal on orbit numbers for SABER. The simulated telescope shield was set to 225 K, the cold block on the refrigerator was set to 73.4 K, the spacecraft shield temperature was set to 293 K, and the reject temperature of the refrigerator was left at 273 K. This data point is shown as point C on Figures 12 & 13. The predicted heat loads during operation at this point were approximately 260 and 320 mW depending on which curve is referenced.

Also of interest to the SABER team was the temperature stability of the cold block and the detector plane. To ensure accurate data collection, the temperature of the detector plane must remain stable to a drift rate of .05 K/minute or

less. Figure 14 shows the temperature on the cold block while Figure 15 shows the temperature of the detector plane. The temperature of the detector plane is actually much more stable than that of cold block even though the Figures 14 & 15

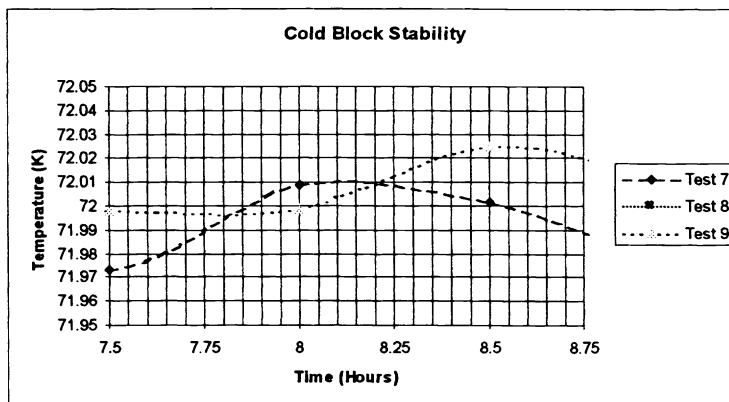

Figure 14. Cold block temperature stability.

appear to be opposite that conclusion. The data collection system used during the test would record the temperature immediately upon changing to the new channel. This did not allow time for the Lakeshore 208 to settle out as is evident by the temperature data. If allowed to settle out for 10 seconds before the reading was recorded, the temperature is actually more stable on the detector plane than that shown in Figure 14, which is based on data taken from the TRW electronics. The data recorded on this system was written just prior to updating the screen, which allowed for settling time. As can be seen from inspecting the cold block stability chart, .05 K/min. appears to be an achievable value.

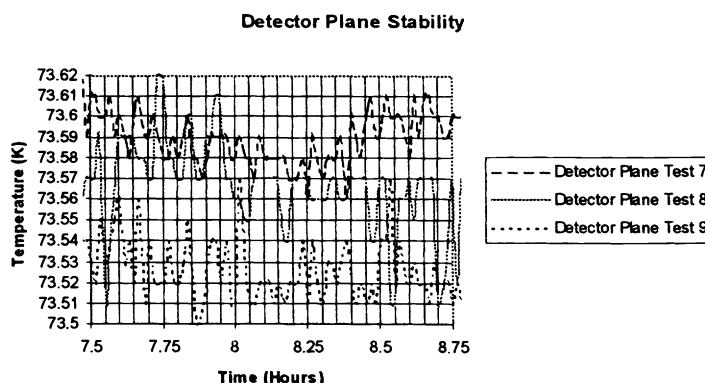

Figure 15. Detector plane temperature stability.

4.0 SUMMARY

This testing provided SDL an excellent opportunity to learn about potential problems associated with integrating the TRW pulse tube refrigerator into an instrument. It also provided a unique opportunity to learn if the current design of the SABER FPA is viable. The test proved to be a success with many lessons learned.

As seen from the test results, the predicted heat loads were somewhat optimistic when compared to the actual values obtained. This is attributed to the fact that the MLI blanketing around the FPA was not as good as predicted. The blankets being used are small enough that edge effects play a large part in overall blanket effectiveness. If the heat load values obtained during testing, from the compressor data, are plugged into mathematical and SINDA models, and effective emittance for the blanket can be calculated. The value for the effective emittance was then found to be .038. Using the heat loads predicted by the calibrated thermal link, the effective emittance was calculated to be approximately .048. The heat load predictions were updated with effective emissivities backed out from the FPA testing and new predictions made based on heat loads obtained from the calibrated link (See Figure 16).

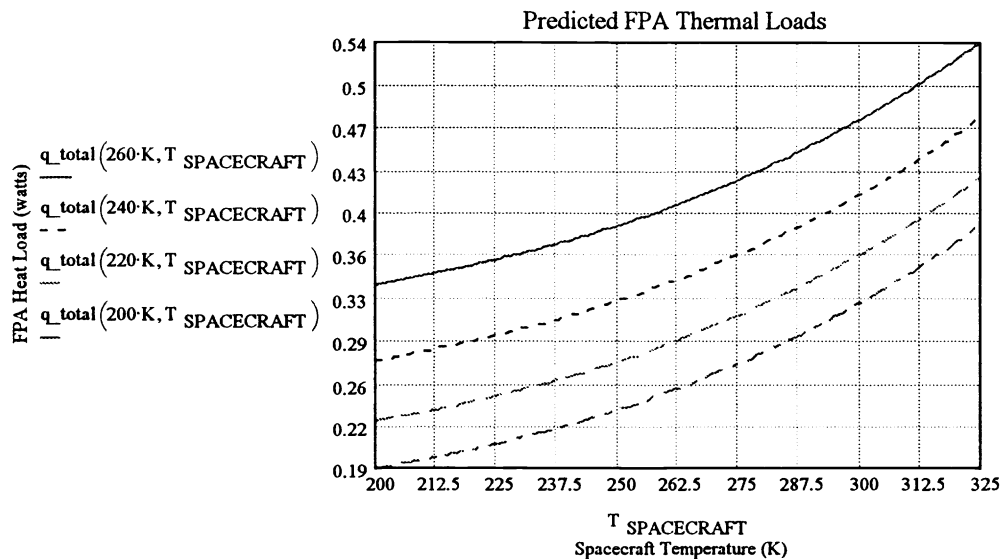

Figure 16. Predicted FPA Heat Loads Using Calibrated Link Heat Loads From Test

A summary of the test points of interest are shown in the Table 1.

Table 1

Reject Temperature (K)	Cold Block Temperature (K)	FPA Shield Temperature (K)	S/C Shield Temperature (K)	Compressor Power (watts)	Calculated Heat Load (Comp.) (mW)	Calculated Heat Load (Link) (mW)
272.0	72.0	218.0	258.0	16.34	238.0	291.0
272.0	72.0	240.0	260.0	17.15	299.0	348.0
273.5	73.4	225.0	293.0	16.85	260.0	343.0
284.0	72.0	240.0	323.0	20.68	425.0	395.0

This testing proved to be a very valuable experience for the SABER team. Much was learned about integrating the TRW pulse tube refrigerator with the SABER FPA. Everything considered, the test was a success. Although the heat loads were slightly higher than expected, the refrigerator had sufficient capacity to cool the FPA. The testing alerted the SABER team to a few problems, which needed to be addressed. One example would be the inability to cool the cold block in temperature control mode without tripping the compressor. There is also a need to work on better radiation isolation to reduce the parasitic heat loading affects.

5.0 ACKNOWLEDGMENTS

We would like to thank Phillips Laboratory for the use of their pulse tube refrigerator to test our FPA. This was very beneficial to the SABER program. We would also like to thank TRW and NASA Langley for their assistance in making this test possible.

6.0 REFERENCES

1. R. W. Esplin *et al*, "SABER instrument overview." *SPIE Proceedings*, Vol. 2268, pp. 207-217, (1994).
2. Burt, William W. 1995. SABER SRR, Volume I, 5 April 1995 to 6 April 1995. Logan, Utah State University, Space Dynamics Laboratory.
3. Burt, William. Interview by author, November 1995.